

# INNOVATIVE ENVIRONMENTAL TECHNOLOGIES

---

## FIELD HEARING

BEFORE THE

COMMITTEE ON  
ENVIRONMENT AND PUBLIC WORKS

UNITED STATES SENATE

ONE HUNDRED SEVENTH CONGRESS

FIRST SESSION

ON

EMERGING ENVIRONMENTAL TECHNOLOGY  
AND NATIONAL ENERGY POLICY

---

MAY 30, 2001—DURHAM, NH

---

Printed for the use of the Committee on Environment and Public Works



U.S. GOVERNMENT PRINTING OFFICE

80-649 PDF

WASHINGTON : 2003

---

For sale by the Superintendent of Documents, U.S. Government Printing Office  
Internet: [bookstore.gpo.gov](http://bookstore.gpo.gov) Phone: toll free (866) 512-1800; DC area (202) 512-1800  
Fax: (202) 512-2250 Mail: Stop SSOP, Washington, DC 20402-0001

COMMITTEE ON ENVIRONMENT AND PUBLIC WORKS

ONE HUNDRED SEVENTH CONGRESS

FIRST SESSION

BOB SMITH, New Hampshire, *Chairman*

HARRY REID, Nevada, *Ranking Democratic Member*

JOHN W. WARNER, Virginia

JAMES M. INHOFE, Oklahoma

CHRISTOPHER S. BOND, Missouri

GEORGE V. VOINOVICH, Ohio

MICHAEL D. CRAPO, Idaho

LINCOLN CHAFEE, Rhode Island

ARLEN SPECTER, Pennsylvania

BEN NIGHTHORSE CAMPBELL, Colorado

MAX BAUCUS, Montana

BOB GRAHAM, Florida

JOSEPH I. LIEBERMAN, Connecticut

BARBARA BOXER, California

RON WYDEN, Oregon

THOMAS R. CARPER, Delaware

HILLARY RODHAM CLINTON, New York

JON S. CORZINE, New Jersey

DAVE CONOVER, *Republican Staff Director*

ERIC WASHBURN, *Democratic Staff Director*

# C O N T E N T S

---

Page

## MAY 30, 2001—DURHAM, NH

### OPENING STATEMENT

Smith, Hon. Bob, U.S. Senator from the State of New Hampshire .....	2
---	---

### WITNESSES

Alix, Frank, CEO and president, Powerspan Corp. ....	6
Prepared statement .....	34
Andary, Casimer, director, Regulatory Programs, Alliance of Automobile Manufacturers .....	24
Prepared statement .....	60
Bayer, Judith Ann, director, Environmental Government Affairs, United Technologies Corp. ....	8
Prepared statement .....	36
Eidlin, Richard, vice president and business development director, Solar Works, Inc. ....	12
Prepared statement .....	50
Funk, David, Great Bay Stewards .....	31
Goldstein, David B., Ph.D., Energy Program co-director, Natural Resources Defense Council .....	19
Prepared statement .....	53
Hodsdon, John, Meredith, NH .....	34
Itse, Hon. Daniel, New Hampshire State Representative .....	32
Kelly, Tom, Ph.D., director, Office of Sustainability Programs, University of New Hampshire, Durham, NH .....	21
Prepared statement .....	56
Moses, John, CF Technologies .....	30
Sundberg, Donald, vice president for Research and Public Service, University of New Hampshire .....	1
Taylor, George, CEO and president, Ocean Power Technologies, Inc. ....	10
Prepared statement .....	45
Wilson, Joshua .....	31

### ADDITIONAL MATERIAL

Fact Sheets:	
Why Should Congress and the Administration Support a Stationary Fuel Cell Tax Credit? .....	43
The Stationary Fuel Cell Incentive Program .....	44
Letter, Public Service of New Hampshire .....	64
Statements:	
Bearden, T.E., Ph.D., LTC, U.S. Army (Retired), CEO, CTEC Inc. ....	87
Chubb, Scott, Ph.D., physicist, Naval Research Laboratory .....	85
Gat, Roy, Ph.D., Advanced Electron Beams, Inc. ....	61
Glanz, Filson H., professor emeritus of Electrical Engineering, University of New Hampshire .....	62
Greer, Steven M., M.D., former chairman, Department of Emergency Medicine, Caldwell Memorial Hospital .....	68
LaViolette, Paul A., Ph.D., former president, Starburst Foundation Institute .....	81
Lewis, Rone III, senior vice president, Ingersoll-Rand (IR), president, of IR's Independent Power Sector .....	63

	Page
—Continued	
Loder, Theodore C. III, Ph.D., Institute for the Study of Earth, Oceans, and Space, University of New Hampshire, Durham, NH .....	65–68
Mallove, Eugene, Ph.D., editor-in-chief and publisher, Infinite Energy Magazine .....	87
Valone, Thomas, M.A., P.E., president, Integrity Research Institute, Washington, DC .....	71–81

## **INNOVATIVE ENVIRONMENTAL TECHNOLOGIES**

**WEDNESDAY, MAY 30, 2001**

U.S. SENATE,  
COMMITTEE ON ENVIRONMENT AND PUBLIC WORKS,  
*Durham, NH.*

The committee met, pursuant to notice, at 2:15 p.m., at the Stafford Room, Memorial Union Building, University of New Hampshire, Durham, New Hampshire, Hon. Bob Smith (chairman of the committee) presiding.

Present: Senator Smith.

Senator SMITH. If I could have order in the house, we will call the hearing to order and I apologize for the brief delay in getting here from over in Dover.

I would like to call on Mr. Donald Sundberg, the vice president for Research and Public Service with UNH first for a few remarks.

### **STATEMENT OF DONALD SUNDBERG, VICE PRESIDENT FOR RESEARCH AND PUBLIC SERVICE, UNIVERSITY OF NEW HAMPSHIRE**

Mr. SUNDBERG. Thank you Senator Smith. It is a pleasure to have you here again. You are a welcome guest to the University of New Hampshire and you are a welcome resident of the State of New Hampshire. I want to extend to all of you in the room a warm welcome from the whole UNH community as you gather here for this Senate hearing. As part of the public service mission of the University of New Hampshire: we are a land grant, sea grant and space grant organization; we have a special need to serve the public at large, and hosting events like this one today is one of the ways we like to do this.

Last year, in fact, we were fortunate enough to work with Senator Smith and his EPW staff to organize and orchestrate a symposium called Environment and Public Works Issues in New Hampshire. Then provided for a very effective forum to discuss and to debate air and water issues, transportation and super fund issues and natural resource and wildlife issues. I really hope that today's hearing will generate the same kind of energy and insightful discussions as we experienced last year.

If I might, I'll need to take a moment to tell those of you in the room who don't know very much about UNH a bit about us. I know we have a number of visitors here today. We are, as I said, a land grant institution and so serve the State in that capacity. We are one of the two research institutions in the State and we have about 12,000 students here: about 10,500 undergraduates and around

2,000 graduate students. We have 700 faculty serving those students—note that I put the word on “service”—and a wonderful staff helping the faculty support the students and the State. We serve the teaching research and public service outreach needs of this State and surrounding region with a long-term commitment to sustainability issues and I want to thank Dr. Thomas Kelly and his staff—Tom directs our office of sustainability programs here at the University—for working to assist the Senator and his staff in putting on this hearing for you today. I suspect that today Tom, in his testimony, will mention some of his program such as climate education initiative, which is a strong program here and linked to our climate change research center, very strong program at the University of New Hampshire in talking about the issues of sustainability.

So last, I know that Senator Smith attended this morning a demonstration of innovative water treatment technologies in the State and on that theme of innovation, I really hope this afternoon that you will continue the innovative thoughtfulness and insightfulness as it applies to energy and surrounding issues.

So Senator, welcome to the University of New Hampshire, your staff, members of the audience I hope that you will have a very energetic and worthwhile discussion.

**OPENING STATEMENT OF HON. BOB SMITH, U.S. SENATOR  
FROM THE STATE OF NEW HAMPSHIRE**

Senator SMITH. Thank you very much Dr. Sundberg, I appreciate your comments and I just want to make a few brief remarks and a few housekeeping things and we will go right to the witnesses.

First of all, I didn't anticipate when we scheduled this hearing that this would probably be the last hearing for a while that I would be chairing as the Environment and Public Works Committee Chairman, but you never know how things are going to work out—but, it's not going to do anything as far as my involvement on the issues that I care about. I will be just as involved as the Ranking Republican Member on the committee and working with Senator Jeffords for the good of New England, and certainly, New Hampshire.

I want to thank the University of New Hampshire for hosting this event. I know it is a lot of work to do that and I am very grateful to you for it. I want to thank all of you for being here today, especially those who have come with the new technologies.

When I became the chairman almost 2 years ago, I felt that I wanted to change the direction of how we develop our environmental policy. I wanted to go away from the stovepipe, top down regulatory regime and go to thinking outside the box a little bit and develop some new, innovative, flexible and effective weapons. In other words, market-based solutions where we can. I think you are going to hear a lot of market-based solutions today. I was trying to move toward a cooperative approach where we focus on results with more innovation and less regulation and that is what this hearing is all about.

I am honored to be here at UNH to highlight the tremendous work of America's companies and frankly, the tremendous work of the University of New Hampshire, because they are leaders in a lot of innovative technology that doesn't relate to energy, but relates

to other environmental issues as well as energy. As Dr. Sundberg said, we were just over at Somersworth with some water infrastructure innovations—but a clean environment in the future of our national energy security depends on their ingenuity. That is where the answers are going to come. We saw what happened in California, we haven't got a California problem, but we have felt the brunt of high heating costs and high gas prices so we know that much, that it can impact us in a negative manner. Our economy though is also tied to a national economy and it could take a very heavy hit if we do nothing, so we were asked by the leadership in the Senate to host a series of energy related hearings around the country and I was pleased to do my part.

The solution to our problems must be comprehensive however. We need new energy production. We are not going to be focusing a lot on that today, views are focusing more on new technology, but we cannot ignore the fact that we need new energy production. We have to modernize and expand our antiquated delivery system for that energy and vastly increasing our conservation and energy efficiency efforts which to a large extent, we are going to focus on here today.

If you all saw the vehicles outside, I spoke to Ford just on the way in and they have developed a hydrogen cell vehicle which he said is ready to go on the road in 2004. So all of us complainers about energy, we ought to start buying the hybrid and the hydrogen cars, and I told them when they get one that I can sit in, I am going buy. But, we need an energy policy before we develop into a major crisis and I am pleased that we are working on it to fix it. It is a short term problem, but it's also a long term problem. And the long term, you see the answers in those automobiles out there. The short term, you know, we still have to heat our homes and run those gas guzzlers that we have while we have them.

I am pleased to be here today, because its important that Congress and the Nation understand what technologies are out there and what they are capable of. One of the frustrations that I felt in Congress over the years has been the fact that we react to everything rather than act proactively and here is an opportunity now to hear real leaders, people who have led in their respective disciplines and here is a chance to showcase what they have done. They are vital to our long term national interest and I think I recognize this and I think the President's plan recognizes this even though there will be some differences as to the energy plan of the President, in terms of details at least, there is an energy plan. In fact, 42 of the President's 105 recommendations in his energy policy are intended to modernize and increase conservation and environmental protection. That hasn't gotten a lot of play, but it is true. It is obvious that at this time it is necessary to call upon these breakthroughs to propel our Nation through this difficult strategy.

[The prepared statement of Senator Smith follows:]

STATEMENT OF HON. BOB SMITH, U.S. SENATOR FROM THE STATE OF  
NEW HAMPSHIRE

Good afternoon and welcome to this hearing of the U.S. Senate Committee on Environment and Public Works. I would like to thank the University of New Hamp-

shire for hosting this event, and I also want to thank all of you for coming here today to talk about clean, innovative technologies.

When I became chairman of the Environment & Public Works Committee, I wanted to change the direction of how we develop our environmental policy. I wanted to narrow on approaches that move away from a stove-pipe, top-down regulatory regime. We were in search of remedies that involved thinking “outside the box.”

The need for our Nation is to develop new, innovative, flexible and effective weapons against pollution. We need effective, market-based solutions; cooperative approaches that produce results; and more innovation and less regulation. That is what this hearing is all about.

I am honored to be here at UNH to highlight the tremendous work and ingenuity of America’s companies, many from New Hampshire, that have developed these technologies.

A clean environment and the future of our national energy security depend on their ingenuity. While New Hampshire is a net exporter of electricity and does not face the energy crisis that has gripped California—we have felt the brunt of high heating costs in the winter and high gas prices in the summer. Our economy also is tied the national economy, which will take a heavy hit if we do nothing to address this situation.

The solution to this problem must be a comprehensive effort including:

New energy production,

Modernizing and expanding our antiquated delivery system, and

Vastly increasing our conservation and energy efficiency efforts.

I believe that we must create an atmosphere that encourages innovation and will ensure safe, reliable energy. I commend President Bush for taking action and developing his National Energy Policy. After 8 years of a total lack of leadership, or willingness to address this crisis that we knew was looming on the horizon, I am pleased we are finally going to do something to fix it.

This comprehensive effort will require new, innovative and environmentally friendly technologies to meet our national energy needs and our desire for a clean, healthy environment. That is why I am holding this hearing today. It is important that the Congress and the Nation understand what technologies are out there and what they are capable of. I want to use this opportunity to showcase them especially those being developed right here in New Hampshire.

Innovative technologies are vital to our long-term national interest. I recognize this, and the President’s plan recognizes this. In fact, 42 of the President’s 105 recommendations in his Energy Policy are intended to modernize and increase conservation and environmental protection efforts.

It is obvious that at this time it is necessary to call upon these break-throughs to propel our country through this difficult energy situation. There has long been the assumption that we could not have a strong energy supply while maintaining a strong environmental policy. A common belief is that you must sacrifice the one in order to obtain the other.

What I believe, and what we are going to see today, is that you can have both a reliable, affordable and adequate long-term energy supply and a clean, healthy environment.

These technologies will free us from the false choice of energy or environment. The Energy Star program is an example of an innovative partnership designed to help consumers and businesses benefit from energy efficiency. The idea behind Energy Star was to get manufacturers to produce products that required less energy. Energy efficient products would be labeled and easily recognized, allowing consumers to purchase products they knew to be environment friendly while ultimately saving money by lower energy costs and preserving the quality of the product.

Nationwide, Energy Star products save over \$2 billion in energy costs. Here in New Hampshire, we have 73 companies and public entities participating in Energy Star. New Hampshire has 22 million square feet of building space that is currently committed to the Energy Star Program. In addition, because of existing Energy Star investments in New Hampshire:

Nitrogen Oxide emissions will be reduced by 4.5 million lbs.

Sulfur Dioxide emission will be reduced by 9 million lbs.

Carbon Dioxide (CO<sub>2</sub>) emissions—Energy Star investments already made will prevent the release of over 2.5 billion pounds of Carbon; That is an equivalent to the reduction in Carbon that you would get from planting 348,000 acres worth of trees.

Achieving success through innovation, not regulation.

It is worth noting that two of the Energy Star labeled products are manufactured in New Hampshire. In addition to Energy Star, there have been many other efforts to increase energy efficiency.



Something that I have been talking about now for some time is that of next-generation vehicles. Over the last few decades, we have done a good job in reducing our vehicle emissions. The cars and light trucks of today are 96 percent cleaner than their counterparts of 30 years ago. The vehicles of 2009 will be 80 percent cleaner than today's cars. But we need to take that to the Next Generation—I want to provide the incentives so that we can bring the Super-Clean vehicles to the mainstream. Again, this is an important part of the President's plan.

I am very pleased that we have hybrid and fuel cell vehicles on display, but we also have a number of other technologies here today that will lead us into a cleaner future:

Power Span, whose technology has the capability of revolutionizing the reduction of power plant emissions. This is a technology that I have been citing as I have been promoting my multi-emissions strategy, because it is an example of being able to increase our energy production, yet decrease our emissions.

Solar Works is here to discuss their solar, and other clean energy technologies.

United Technologies is here to talk about advances in fuel cells.

Ocean Power is going to tell us how we can harness the energy of the seas.

We must embrace these types of technologies. They are clean and plentiful—they are the future. They are a key part of any viable, long-term energy solution. I recognize this, and the President recognizes this.

I am proud that I am able to showcase these innovative solutions to the Nation. Thank you all for coming here today and I anxiously await your testimonies and the opportunity to share them with my colleagues in the Senate.

Senator SMITH. Let me now just turn to a couple of details before I go to the panel. It is generally the committee's practice to limit oral remarks to 5 minutes. Every word of your statement will be made part of the record automatically, you can summarize if you would like or speak extemporaneously, however you like, but your full statement will be in the record. If time allows after both panels have finished, and I believe we will have that time, I will invite comments from the audience. Again, just let me say, I know people love to give speeches and if you want to submit a written statement for the record, you can do that. If you could just ask your question or make your comment in 1 minute, in other words, summarizing whatever it is you want to say, I will put your full statement in the record where you ask the question, the same as we do for the witnesses. I would appreciate it if everyone could be considerate of each other, because I know we have a number of people who want to speak.

So, we are going to try to give each person a minute and if you are interested in making a statement, there is a red sheet, I think, back there on the handout table. Is that right? I do have to leave a little before 4 o'clock and I apologize for that, but if we still have questions, we will gather those questions even after I leave.

On our first panel, I am pleased to have Frank—is that Alix?—Alix, all right, I had a 50 percent chance of being right—Frank Alix, the CEO and chairman of Powerspan Corporation; Judith Bayer, United Technologies; George Taylor, CEO and President of Ocean Power Technologies and Richard Eidlin of Solar Works. I had an opportunity to visit with Richard earlier this year and I am glad that he is here.

Let me start with you Mr. Alix and just say that Powerspan—and they will be telling you about this themselves—the reason why I am excited about it is that they produce technology that may see us reducing NO<sub>x</sub> and SO<sub>2</sub> emissions by as much as 70 percent and perhaps mercury as much as 80 percent. We are very excited about what they are doing, we are proud of them for being here in New Hampshire and we hope that we are going to be able to take a pilot

project that they are working on in Ohio, where they are sending all that stuff over here our way, whereas reducing emissions there and bringing them back over here and working on a couple of plants right here in New Hampshire. So, we are pleased to have you here Frank, and we will hear from you now.

**STATEMENT OF FRANK ALIX, CEO AND  
CHAIRMAN, POWERSPAN**

Mr. ALIX. Thank you Chairman Smith for the opportunity to share our perspective on innovative environmental technology. My name is Frank Alix, I am chairman and CEO of Powerspan.

Powerspan is an emerging energy technology company headquartered in New Durham, NH. Our company was founded in 1994 and has grown to employ 45 people, most in high-paying technical jobs. In order to fund technology development, the company has raised over \$28 million to date from private, institutional and corporate investors.

Over the past 3 years, Powerspan has focused its resources on the development and commercialization of a patented multi-pollutant control technology for coal-fired electric generating plants called Electro-Catalytic Oxidation, or ECO. The ECO technology is designed to cost-effectively reduce emissions of sulfur dioxide, nitrogen oxides, mercury and fine particles all in a single, compact system. Several leading power generators are investors in the company or partners in ECO development. These include FirstEnergy, American Electric Power, Cinergy and Allegheny Energy.

Powerspan has successfully tested this ECO technology in a 2 megawatt slipstream of a coal-fired plant owned by FirstEnergy. During the test, ECO reduced emissions of NO<sub>x</sub> by 76 percent, SO<sub>2</sub> by 44 percent, mercury by 81 percent and total particulate matter by 99.9 percent.

The U.S. Department of Energy recently selected us for a \$2 million grant under a solicitation for promising mercury control technologies for coal-based power systems. In addition, lab testing of our next generation technology is showing nitrogen oxide removal of more than 90 percent and sulfur dioxide removal of more than 99 percent.

Powerspan has begun installation of our first large commercial demonstration at a 50 megawatt slipstream at FirstEnergy's East-lake Plant near Cleveland. The project is being co-funded by a \$3.5 million grant from the Ohio Coal Development Office. Successful completion of this demo will lead to the availability of full scale systems in 2004. So much for the introduction.

My comments are: as you consider the important role of innovative technology in further enhancing our environment, I would like to make the following points:

1. Environmental technology development is driven almost exclusively by environmental regulations. Regulatory certainty and time are important factors that impact the degree to which environmental technology is deployed.

2. The cost of achieving environmental compliance is usually significantly less than estimated at the time regulations are developed.

3. Environmental regulations are not all created equal. Some are more likely to spur innovation than others.

Let me briefly address each of these points.

First, both electric generating utilities and the environmental technology community rely upon long-term certainty in environmental regulation. For the capital-intensive electric generating industry, long-term regulatory certainty allows for the orderly improvement of generating assets without undue financial risk or the threat to the availability of electric supplies as we have seen in California. For the technology community, regulatory certainty provides the incentive to employ the resources to develop and commercialize new technology that will meet regulatory goals in the most cost-effective manner possible.

In the process of crafting environmental legislation, the cost associated with the law's implementation is normally evaluated. These cost assessments are inevitably based upon what is known or commercially proven at the time. The objective of technology developers however, is to make what is known and commercially proven obsolete. This they do on a regular and dependable basis. Therefore, it is important to remember that given time, technology developers will ensure that environmental compliance costs are far less than predicted today.

The ECO technology could provide the environmental benefits of reductions in a number of air emissions, including mercury, years ahead of a typical regulatory schedule and at a lower cost than conventional pollution control technologies. However, the existing regulatory requirements significantly limit the generating industry's compliance flexibility, thereby making the use of multi-pollutant approaches less viable.

Under the current interpretation of best available control technology, or BACT, generating utilities could not use our ECO technology to help achieve NO<sub>x</sub> or SO<sub>2</sub> reductions, even if it were almost as effective as the best available technology and simultaneously achieved reduction of other pollutants such as mercury. Yet, if our ECO technology were deployed throughout the industry, far more emission reductions could be achieved than through selective BACT deployment. And the associated health and benefits would accrue to a much larger percentage of the public. This kind of regulatory inflexibility doesn't make economic sense and more important, doesn't make environmental sense. Therefore, I support the President's National Energy Policy call for multi-pollutant legislation that will establish a flexible, market-based program to significantly reduce the emissions of sulfur dioxide, nitrogen oxides and mercury from electric power generating plants. I believe that Congress should determine the appropriate reduction requirements and timeframe to phase in reductions and then allow industry to meet them in the most cost-effective manner possible. A command-and-control approach would only serve to drive up costs and curb innovation.

In summary, I believe that increasing our energy supply and at the same time improving our environment is not only possible, but imperative for the future well-being of our society. Fortunately, our Nation is blessed with an innovative and entrepreneurial spirit that rises to such challenges. I believe political leaders must exer-

cise a degree of faith in order to establish the environmental laws that look out over a decade or more to protect public health when compliance uncertainty may still exist. Given time and the right regulatory framework, the technology community will find an economical way to achieve the desired environmental benefit. History has demonstrated this time and again and there are many companies like Powerspan full of talented individuals that are dedicated to this goal.

Thank you.

Senator SMITH. Thank you very much and we will come back to you with questions when we get through each panel member. I might say if there are members of the audience who have a question, you might be thinking about them right now.

Judith Bayer, welcome. I have to tell you this, in talking to some of the automobile manufacturers about fuel cells, it's just so exciting to think that the wave of the future is in this technology. Not only in the mobile, but also in some of the stationary forces, so it is really exciting. I'm glad you're here. I had the opportunity to ride in a fuel celled bus, I saw the automobile out there, but I could fit in a bus a little easier—

[Laughter.]

Senator SMITH [continuing]. It really was amazing. It went right up the hill, and on Capitol Hill with no problem, so we are really looking forward to this technology being here so we can all partake of it. Go ahead.

**STATEMENT OF JUDITH ANN BAYER, DIRECTOR OF ENVIRONMENTAL GOVERNMENT AFFAIRS, UNITED TECHNOLOGIES CORP.**

Ms. BAYER. Thank you Mr. Chairman. I'm Judith Bayer, the director of Environmental Government Affairs for United Technologies Corporation. I appreciate the opportunity to testify today.

UTC provides a broad range of high technology products and support services to the building systems and aerospace industries. We spend an average of \$1 billion on R&D each year and have made a significant investment in bringing clean, energy efficient technologies, non-ozone depleting products to the global marketplace.

I want to share some examples of existing innovative technologies from UTC's International Fuel Cells and Carrier divisions and suggest how we might maximize their benefits.

Fuel cell technology is a reality today. UTC has been producing fuel cells for every U.S. manned space mission since 1966. Fuel cells very simply combine hydrogen and oxygen to create electricity, water and heat. I brought with me today a fuel cell. This is a single fuel cell where the hydrogen enters on the left, the oxygen enters on the right and in the presence of a catalyst, produces electricity, water and heat.

IFC is developing fuel cells for residential and light commercial applications and a model of our residential unit is in the back. These units will be commercially available in 2003. Our zero emission fuel cell power plant for the Hyundai Sport Utility Vehicle was unveiled last fall and our prototype zero emission fuel cell buses are taking to the road this year.

IFC's PC25 power plant system has a capacity of 200 kilowatts and is the only commercially available fuel cell power plant in the world today.

IFC's fuel cell technology has proven our ability to produce 1000 kilowatt hours of electricity with only an ounce of pollution; achieve 87 percent efficiency; obtain 99.9999 percent reliability; reduce CO<sub>2</sub> emissions by 60 percent; accumulate more than 4 million hours of operating experience at hospitals, schools, military installations and data processing centers, and perhaps most importantly in today's climate, operate on a variety of fuel sources thus reducing our dependence on imported oil. With all these benefits, you would think that every building in New Hampshire would have a fuel cell. The problem is the technology hasn't reached sufficient volume for the cost to be competitive. We have delivered over 220 of these systems around the world, but we have done that over a 10-year time period, which means we average 20 per year. Imagine how much your car would cost, or your computer would cost, if we only produced 20 per year.

The Federal Government can help speed commercialization of fuel cell technology by granting tax credits and financial incentives, purchasing fuel cells for Federal facilities, removing regulatory barriers, funding a zero emission hydrogen fuel cell bus demonstration program and continuing its investment in hydrogen research and development.

There are other technologies available today that also need Government assistance to reach their full potential. UTC's Carrier division continues to lead the air conditioning, heating and refrigeration industry in: phasing out ozone depleting substances well ahead of domestic and international mandates; increasing energy efficiency; reducing the use of raw materials and product weight; introducing air quality management features; and developing tools to evaluate a holistic building systems approach to indoor comfort cooling. Four million tons of CO<sub>2</sub> emissions could be saved, and enough power for 743,000 homes if older CFC commercial chillers were retired more quickly by simply changing the depreciation schedule for these units from the current staggering 39 years to a more reasonable 10-15 years.

Carrier and others have pioneered technology that improves energy efficiency for residential air conditioning systems without using ozone depleting substances. We support a full 20 percent increase in the Federal Energy Efficiency Standards for residential AC equipment. Incentives should be provided for purchasing equipment that delivers 13 SEER, which is the miles-per-gallon equivalent for air conditioning units with added incentives if the equipment also uses non-ozone-depleting substances.

We applaud you, Mr. Chairman, for introducing S. 207 to help reduce energy consumption in buildings and believe it creates a good opportunity for maximizing both energy efficiency and non-ozone depleting benefits.

Carrier also has the ability to reduce residential peak load demand by 30 percent with its revolutionary, web-enabled smart thermostat technology. For every 100,000 homes that use this equipment, enough power is saved to power an additional 100,000 homes. Federal rebates and consumer incentives would make this

technology more readily available and more quickly deployed. Proper installation of residential AC systems could reduce energy consumption by as much as 35 percent.

AC manufacturers and contractors have formed a national technician training and certification program called NATE—North American Technician Excellence program. The Government could help raise public awareness of this program and encourage Federal facilities to purchase services only from NATE technicians.

Carrier and International Fuel Cells have received awards from EPA recognizing their respective achievements in ozone and climate protection. Their products offer numerous environmental and other benefits that can only be fully maximized with appropriate Government policies, incentives and partnerships.

We look forward to working with you Mr. Chairman and other interested stakeholders to make this possible.

Thank you.

Senator SMITH. Thank you very much, Ms. Bayer.

Our next witness is George Taylor. We had to scout around a little bit to find George, but my staff did a good job, because I have been talking to my staff for a long time about all that ocean out there and why can't we harness that, we are a peninsula Nation with a lot of ocean out there on both of our coastlines and if we could harness that energy, my goodness, what might happen.

And lo and behold, we found somebody who is working on it. It is in the future, we know that, but maybe not too far. You will never get to the future if you don't start thinking about it today, so I am particularly excited about having you here, Dr. Taylor, please proceed.

**STATEMENT OF GEORGE TAYLOR, CEO AND PRESIDENT,  
OCEAN POWER TECHNOLOGIES**

Dr. TAYLOR. Thank you very much Mr. Chairman.

My name is George Taylor and I am the president and CEO of Ocean Power Technologies—OPT. I am here today at the chairman's request to describe our company's new generation technology that utilizes the renewable energy in ocean waves to produce low-cost, pollution free electricity.

OPT is a small, private company located near Princeton, NJ. Even though we only have 14 employees, we have been able to obtain significant commercial orders both nationally and internationally. We expect to do about \$5 million in sales in the next 12 months and then to rapidly grow into a major company building on key strategic relationships which the company has forged over the last couple of years.

The basic configuration of an OPT wave power station is shown in the drawing behind me. It consists of an array of OPT power buoys arranged in a rectangular format several miles offshore. As the ocean waves move through the field of power buoys, the mechanical energy in the waves is converted into electricity in each of the power buoys. The output from each power buoy is then fed in parallel into an underwater cable which brings the power ashore for connection into the power grid.

Wave energy is the most concentrated form of renewable energy. It is widespread throughout the United States and other parts of

the world and it is close to population centers. It is very predictable and dependable and can be fed into the power grid or stored. It is environmentally sound and non-polluting, with no exhaust gases, no noise and no visibility from the shore. It is scalable to high capacity power stations of 100 megawatts or more. In fact, 100 square miles of ocean area off the coast of California, which is a very small fraction of the coastline, is estimated to be capable of producing all of California's electrical power.

Furthermore, wave energy has an availability factor of 90 percent compared to wind and solar availability factors of 20–30 percent. OPT's wave energy generation system is based on the rising and falling of the waves which cause the buoy-like structure to move freely up and down. The resulting mechanical stroking is used to drive the electrical generator, the power from which is then transmitted ashore. The OPT device is a proprietary, smart system that uses an on-board computer and sensors to effectively convert the random wave energy into electrical power. In addition, the OPT system includes sophisticated techniques for automatically disconnecting the system in storm waves and then automatically reconnecting it when the waves return to normal operating conditions.

The OPT power generation system has numerous environmental advantages. There is no fuel, there is complete absence of CO<sub>2</sub> emissions, radiation and particulate matter pollution. There is no noise pollution, nor is there any visual pollution. A field of semi-submerged buoys is typically 1-2 miles offshore in 100 feet of water. Finally, there is no negative effect on marine life. In fact, our tests off the coast of New Jersey have shown that the buoy acts as an artificial reef and encourages the growth of marine life. Furthermore, a field of buoys actually reduces, by taking energy out of waves, the shoreline erosion.

Most importantly, what are the costs? The total operating costs of generating power from an OPT wave power station is projected to cost between 3 and 4 cents per kilowatt hour for 100 megawatt size power systems and 7–10 cents per kilowatt hour for 1 megawatt size plants. Detail comparison costs with other renewable and fossil fuel-based power systems are provided in the written testimony that we have submitted to the committee.

We have tested the complete wave power system off the coast of New Jersey for 11 months, and based on this, we have received the first commercial contracts and these include a 1 megawatt power station for a U.S. Navy base in Hawaii; a grid connected power station of up to 10 megawatts for a utility in Australia and a demonstration system for the State of New Jersey.

The main product applications of the OPT power stations include primary power of 100 megawatts or more for grid power and distributed power generation, many secondary power applications and, of course, power for desalinization and production of hydrogen from sea water.

OPT has received significant support and encouragement from the U.S. Government, in particular from the Office of Naval Research of the U.S. Navy under the Small Business Innovative Research Program and from the Defense Advanced Research Project

Agency. Also, we appreciate the support of the congressional delegations of New Jersey and Hawaii.

In conclusion, the OPT wave power system would appear to be one of the few, and maybe the only renewable power system that has the potential of producing low-cost—below 4 cents per kilowatt hour—a large scale 100 megawatt or more power station that cause no danger to the environment. OPT hopes that the U.S. budget for alternative energy will be increased and will include some funding for wave power.

Finally, I would like to thank you Mr. Chairman, for your interest in this matter.

Senator SMITH. Thank you very much, Dr. Taylor.

Richard Eidlin, I had the opportunity to visit your shop—Wilmore? Wilkin—and you were very impressive and I wanted to have you here today to speak to the future of possibilities of solar. Welcome.

**STATEMENT OF RICHARD EIDLIN, VICE PRESIDENT FOR  
BUSINESS DEVELOPMENT, SOLAR WORKS**

Mr. EIDLIN. Thank you very much Mr. Chairman. You will have to bear with my cold today. I went camping over the weekend and got rained on.

Senator SMITH. Well, pull that microphone right up close so it will make it a lot easier for you.

Mr. EIDLIN. My name is Richard Eidlin. I am the vice president for Business Development for Solar Works. Solar Works is a distributed generation company based in Montpelier that provides solar and other renewable energy systems to residential, commercial and institutional customers throughout the Northeastern part of the United States.

I appreciate the opportunity to present some remarks this afternoon about the important role that solar electric photovoltaic technologies can play in addressing the Nation's energy needs.

First, let me just mention a few things about Solar Works and the work we are involved in. The company was founded in 1980. We are a privately-held firm that employs 17 individuals and we offer a wide range of standardized grid-intertied solar electric, domestic hot water, wind turbine and energy efficiency systems. We are also moving into the fuel cell industry as that market begins to mature. Within the solar industry, our company acts as a renewable energy systems integrator, in that we provide a complete set of technical hardware and programmatic strategies to clients including utilities, State energy offices, cooperatives and others. Solar Works acts as a catalyst that brings together manufacturers, energy service providers, policymakers and consumers to bring the technology to practical use. We maintain, as I indicated, our sales and service offices in eight Northeastern States from Maine to Maryland.

Over the 21 years that our company has been in the renewable energy business, we have experienced several major shifts in public policy, technology development and market acceptance concerning solar electric technologies and today, unlike a decade ago, or even maybe 5 years ago, there is a vibrant market for solar technology



in the United States. As we are fond of saying, “there has never been a better time to create your own electricity.”

A host of factors account for this. First off, solar electric and solar hot water technology is demonstrably more reliable and resilient than it was years ago. Concerns dating back to the 1970s about technological performance have absolutely no bearing on current discussions regarding the role of solar technologies. Solar electric systems have become standardized, they are UL-listed, they use National Electric Code compliant equipment and they require virtually no maintenance. Questions about solar domestic hot water systems have also been resolved in favor of fail-safe, cost-effective equipment. Paybacks have dropped dramatically, hot water systems are now in the 7- to 8-year range and solar electric systems are now in the 25 year range.

The second observation concerns the market for renewable energy. Survey after survey indicates that the American public is highly supportive of clean, domestically generated energy technologies. The past 5 years have witnessed a significant shift in the market. Once largely the domain of off-grid applications, such as water pumping, telecommunication, vacation cabins and rural electrification projects, solar electric technologies are now becoming widely accepted and used for grid-tied homes, businesses and schools across the country.

Homeowners and businesses are choosing solar energy systems for a number of key reasons. These include power quality and reliability; demand for clean, non-polluting energy; growing interest in generating electric power from centralized sources; escalating conventional energy costs; and power shortages including brown-outs and black-outs that were seen in California and may, unfortunately, see here in the Northeast in the summer.

PV is the ideal distributed generation technology. It is well suited for any energy application. PV systems are highly mobile and flexible in nature. Technological advances and performance in design increasingly create a cost competitive energy source. Customers such as the U.S. Postal Service understand these inherent advantages that they have over backup fossil fuel generators. While a fossil fuel generator mainly sits idle and depreciates, a solar energy system, accompanied by battery, lowers monthly utility bills and can provide 24-hour automatic, uninterruptible power supply. PVs can be easily sited, require comparatively little permitting and produce 99.9 percent reliable power. PVs also provide an excellent hedge against almost certain energy inflation.

With today's increased reliance on computers, telecommunication systems and other high performance electronic devices, any loss of power, or even power quality, can be very costly. We are finding that a great number of businesses and homeowners are concerned and choosing to install solar systems.

PVs are also an excellent means of shedding load demand and avoiding summertime peak power cost, which last summer in some parts of the country soared to \$600 a megawatt. PVs, because they are highly dispatchable, offer utilities and business the option of reducing congestion on the grid and moderating the demand for additional power plants and generating capacity. For homeowners, PVs—or photovoltaics—provide an assurance that the power will

stay on in the event of a blackout due to a natural disaster or power scarcity.

Recent studies of the large scale power failures during the winter of 1998 and 1999 in both the Northeast and Northwest strongly suggest that scaled PV installations placed along the grid could have prevented the blackouts from cascading from State to State. It is regretful that the Federal Government, during both the 1990s and today, has committed disproportionately limited resources to supporting the photovoltaics industry. In contrast, most of the action and progress has been made at the State level. Today, over 40 States have enacted one or more requirements to actively encourage the broader use of renewable energy technologies. Net metering, State income tax credits, renewable portfolio standards, system benefit charges are only some of the ways that renewables are being encouraged at the State level by public utility commissions and legislatures. In six States alone—California, Illinois, Massachusetts, New Jersey, New York and Pennsylvania—almost \$400 million a year is being collected from taxpayers through rate-payers, through electric restructuring to support renewable energy deployment. These funds will leverage about five times their value in retail market activity.

The upshot of all this is that the domestic solar energy market will grow ten-fold in the next 5 years from 80 megawatts to almost 900 megawatts of installed capacity. According to the Energy Information Agency, photovoltaics will be the fastest growing generation technology in the United States over the next 20 years. Solar energy may still be a niche market compared to fossil fuel generated power, but it will be a multi-billion-dollar-a-year opportunity for those companies involved.

There is a historic market opportunity emerging in the United States for renewable energy technologies. Demand for zero emission generation technology to combat global warming and air pollution is another important market driver. The current California power crisis is a good example of the inability, and in some cases, unwillingness, of utilities to build new central stations and transmission facilities. The answer to this lies in distributed generation systems that can be tucked neatly into homes, neighborhoods and businesses.

Given these trends, it is of concern that the Administration's energy plan devotes limited attention toward the role of solar technologies. The substantial reductions in the Department of Energy's administrative and R&D budget for renewables is an unfortunate approach to balancing the budget. In addition, these policies are placing the domestic solar energy industry at a competitive disadvantage to their European and Japanese counterparts. Relative to investments that other advanced industrialized nations have made in supporting photovoltaics over the past decade, the U.S. Federal Government has directed modest resources.

Let me return to the immediate issue of the Administration's proposed energy plan. Solar Works supports the proposed \$2,000 income tax credit for residential systems. We also support pending legislation that would establish a national standard regarding the process by which solar electric systems are interconnected to the

utility grid and we are also in favor of a renewable energy portfolio standard.

We look forward to working with the Senate Committee on the Environment and Public Works in crafting policies that help to accelerate the commercialization of solar electric technologies and we appreciate very much the Senator's support in these activities.

I just wanted to very quickly give you a sense—this is a solar electric panel. You may be aware of these, but basically, the sunlight hits this module, the sunlight is converted into electricity, boron and phosphorus are doped with a silicon, if you might remember from your chemistry classes many years ago, and that produces a photochemical reaction. This is a 21 watt module and the modules we work with range in size up to 300 watts, which are more the size of 4x4s. This is one of the smaller panels available.

Thank you.

Senator SMITH. Thank you very much, Mr. Eidlin.

I am going to ask a question or two of the panel and then we will bring the next panel up and then we will open it up to the audience for both panels at the same time.

Mr. Alix, the technology that you are talking about is fascinating when you put it into perspective in the sense that if you could reduce 2.5 billion pounds of carbon say nationally, that is the equivalent of planting 348,000 acres of trees in terms of the impact on the carbon release in the environment. So, I guess the question I would have is: What does this technology mean for coal-based generation? Does it tell us that the 250 years or so of coal that we still have, does it tell us that we can burn that coal with some anticipation of it being clean, or is that too far in the future to predict?

Mr. ALIX. I think its important to differentiate what we know from our technology and what we don't. There are pollutants that are immediate public health concerns from coal-fired plants. Sulfur and nitrogen which lead to acid rain and ozone formation and metals such as mercury that get in the food chain and are also serious public health concerns, and finally, fine particles. Those are the four pollutants that we can remove at high percentage levels for a very reasonable cost and in a compact retrofit.

I think the immediate public health concern around the vicinity of a plant could be drastically reduced. The one area that we don't address is quite clear, carbon and global warming, and I think that is a concern which needs to be addressed. Congress and this Administration will eventually grapple with that.

That question of how long you can burn coal and/or gassify and remove the carbon is something that we need to answer down the road. Our technology addresses what are conventionally called "criteria pollutants" and then mercury and what are the immediate public health risks associated with living in the vicinity of plants or even down-wind from Midwestern plants.

Senator SMITH. You talk about command and control. One of the interesting things about technology is that it reduces mercury, at least in a preliminary result of about 80 percent, and we don't regulate mercury today. So, if that were to be the case, if your research turns out to be accurate, that has a tremendous impact on moving away from command control and more focusing on the technology to get it on to these plants.

Mr. ALIX. I think the day you can put on a small retrofit like ours and address really these four major pollutants, it changes the whole debate. There is no question that the cost would be significantly reduced and the retrofit problems go away as well.

Senator SMITH. At the national level, I have been working privately with many members of the industry and the environment over the last year-and-a-half, because I have been chairman, to work on a cap and trade bill where some plants could get some credits for retrofitting with this kind of technology which would—the positive spin-off would be reductions, NO<sub>x</sub>, SO<sub>x</sub>, mercury and carbon as well. So, it is very exciting technology and we are looking forward to it. When do you expect to get the results finally on your pilot project?

Mr. ALIX. Well, the pilot results are in. It's really the commercial unit that we are building out in Cleveland in about the spring of next year—about a year from now, we should have some great results.

Senator SMITH. All right. Don't be afraid to bring that over here and try that here in New Hampshire.

Mr. ALIX. We won't.

Senator SMITH. Ms. Bayer, obviously the thing that jumps out at you in your testimony is the fuel cell cost. You mentioned \$4,500 per kilowatt obviously would be—I think—what's the average, \$1,500?

Ms. BAYER. Right.

Senator SMITH. What is the future for getting those costs down?

Ms. BAYER. Well, we have seen a dramatic improvement already in reduction of fuel cell costs. The space fuel cells that I mentioned in my oral testimony cost \$600,000 per kilowatt, so over the past decade, we have gone from \$600,000 to \$4,500. The goal is really to get these fuel cell units to a cost where they are competitive in the automotive applications. The target there is \$50 per kilowatt by the year 2010 to make the fuel cell technology competitive with conventional technology. And, to get the technology into homes, cars, trucks and buses so that it becomes a real technology changer for our lifestyle and for our energy needs here in the United States.

Senator SMITH. So it is more of a mass production issue than a technological issue?

Ms. BAYER. It is a series of issues. The reduction in costs that we have seen have been improvements in the technology, improvements in manufacturing processes as well as the potential for increased volume. When a supplier sees the potential for selling to the auto makers their technology with volumes in the millions, then they start to invest in plants, then they start to invest in the R&D and then they see a real potential payoff for those investments. That's what really will help drive the cost down and that is where we think in this transition period, the role of the Federal Government to offer those tax incentives and to offer grants will help accelerate that process.

Senator SMITH. Thank you.

Dr. Taylor, when you look at your picture of the buoys, the first reaction when you look at it is, the energy concept sounds great, but you know, what about all the whales and the fish and the fishing boats and the nets and whatever else might be out there get-

ting all tangled up in this and the eyesore? So, how big a footprint are we talking about here?

Dr. TAYLOR. Well, a 100 megawatt power station would occupy about 1 square mile of surface area.

Senator SMITH. A couple of miles out?

Dr. TAYLOR. A couple of miles out. Given the size of the ocean, the systems are not visible from the shore. They are slightly submerged, about 1 meter below the surface. We have gone through the permitting process off the coast of New Jersey with the Coast Guard and in Australia we have done it with the Maritime Authority over there. The first thing is to define where you are going to put it so that it is not in a shipping channel. Once you have achieved that particular goal, which is easy to achieve, because the shipping channels only take up a very small fraction of the ocean, then you put the appropriate navigation aids on the buoys which are a mast with lights and a radar reflector. The anchoring is very straightforward. It is a column that just goes straight down to the seabed. Fish and whales do not get confused by that type of thing. The basic technology that we are using to encapsulate our system is a buoy. Buoys have been in the water for 100 years or more, and if they are properly maintained, there is no problem. If a boat was to go astray and go into a field of buoys, the normal thing that happens is scraping of paint, the buoy pushes away from the boat and visa versa. There is very little chance that there would be any damage and, in fact, we have been able to get commercial insurance on our systems at very reasonable rates for both liability and damage to the system.

Senator SMITH. Without commenting on the aesthetics of it for a moment, what about the concept—it just seems to me a smaller footprint would be something like a wheel that you see in a hydroelectric plant along a river somewhere. Why would that not work? Why would that technology not work as opposed to all those buoys?

Dr. TAYLOR. A large water wheel?

Senator SMITH. For example.

Dr. TAYLOR. Well, the economics make more sense with our system. We have looked at other types of ways of harnessing water flow and wave energy, but the simple motion of the buoy which bobs up and down is the best. It doesn't fight the wave, it moves with the wave, therefore, you don't have to build enormous structures which are very expensive to withstand big storms. The system we have had in the water off the coast of New Jersey, experienced 12 meter waves—there was a summer hurricane that went through that area and the system survived quite well.

Senator SMITH. And you get more energy with the several smaller buoys than you would get from 2 or 3 larger buoys?

Dr. TAYLOR. Well, that is a good question. Our current buoy size is designed to produce 20 kilowatts of power from each buoy. We are working on a 100 kilowatt size buoy which is physically larger and we ultimately expect to build a megawatt size buoy. But, the modular approach has advantages, because having a lot of buoys means that you can, from a maintenance viewpoint, take one buoy out of the water and refurbish it with very small decrease in the total amount of power coming out of the power station. Also, when you build an OPT power station, immediately you start putting the

buoys in the water, you begin generating power and hence generating revenue. So, its not the normal period of waiting 3 or 4 years to build a power station. Thus, there are advantages by having a modular system. The ultimate size of each module we think is probably going to be a megawatt.

Senator SMITH. Thank you.

Mr. Eidlin, for you I remember when I was out at your place, you seemed to have felt neglected somewhat by the Federal Government in terms of any help from them for you as plenty of research and development of energy, but not in solar.

What specifically would you like to see from the Federal Government level to help you with producing more solar power in this country? Not you specifically, but generically in the country.

Mr. EIDLIN. I think, speaking on behalf of the industry, Senator, a few things come to mind.

One, the national renewable energy labs. The particular lab in Golden, Colorado, and the other labs concerned with renewable energy technologies have been—the allocations for those labs have been cut in the proposed budget. That does not help the rapid commercialization of the technology, because much of the work that is undertaken in those labs then finds its way into commercial applications in the private sector.

Second, the Administration's proposed budget cuts, by significant portion, if not zeros out, the international funding for renewable energy work for domestic companies to do work in India and South Africa. There is a very, very significant market overseas and we are losing market share, particularly to the Japanese companies and Europeans who have greater support.

Third, the enactment of a Federal income tax credit would be quite significant. If that takes place, we would like to see it expedited so that we don't lose the short-term benefits of people waiting 2 years until such a tax credit is enacted.

Senator SMITH. If we did implement a cap and trade program, would it be acceptable to your industry if some forbearance were to be granted to say a coal utility—let's say we step back from this source review and return for that investing, instead of putting the money into resource review of fines or upgrading an older plant that we might like to take offline a few years—if those dollars could be invested into your industry, would that be something that you would tolerate as an industry?

Mr. EIDLIN. Yes, we would be very excited about that prospect and I know you are a champion of that as we discussed.

Senator SMITH. We are exploring it. We are looking at it as an option, yes.

Mr. EIDLIN. Combining solar electric systems with other technologies onsite at distribution facilities makes a great deal of sense. Essentially, as we have discussed, from our perspective this creates jobs as economic benefit and as environmental benefit. And, we think its a very strategic way to build the industry and also produce these parallel benefits that may be in contrast to planting trees in Costa Rica which is also important, but in order to further the industry, some larger scale projects, such as the ones you have been describing would make sense.

Senator SMITH. Well, let me see. Thank you to each and every one of you. I know in a couple of cases, you had to travel quite a way and I appreciate it. I am going to call the next panel up and I might just say to this panel, if you can stay, we would appreciate it and in case the audience has some questions, we will just have everybody come up in the end. If you can't and have to leave, that's OK too.

Let me bring the next panel up.

Dr. Tom Kelly, the director of the Office of Sustainability Programs at UNH; David Goldstein, the energy program director for the Natural Resources Defense Council; and Cass Andary, director of Mobile Source Affairs for the Alliance of Automobile Manufacturers.

Same rules, approximately 5 minutes and your complete statements will be placed in the record and summarize them if you can.

**STATEMENT OF DAVID GOLDSTEIN, ENERGY PROGRAM CO-DIRECTOR, NATURAL RESOURCES DEFENSE COUNCIL**

Mr. GOLDSTEIN. Thank you very much Mr. Chairman. My name is David Goldstein. I am energy program co-director for the Natural Resources Defense Council. We are a national environmental organization with over 400,000 members.

I want to begin by thanking you Mr. Chairman for convening this hearing on new technology and particularly energy efficiency. I would like to personally commend you on your leadership on S. 207 which, I believe will provide desperately the needed relief to our over-stressed electricity and gas grids in a timely manner and can be a big part of an energy solution to this country.

Energy efficiency is a critical piece of national energy strategy, because it impacts people in the ways that they care about most.

First, their energy bills; and second, protecting environmental quality. Energy efficiency directly improves the situation with respect to those key issues. NRDC believes, and we hope, Mr. Chairman, that you agree, that the primary purpose of the national energy policy should be to minimize the cost of providing energy services to a growing economy. That is cost to the pocketbook as well as cost to the environment.

If that's the goal, energy efficiency means providing the same energy services for a lot less energy consumption and cost—which is going to mean reliance on technology, and particularly reliance on new technology. The opportunities are almost limitless.

Since 1973, the American economy has reduced the amount of energy it takes to produce a dollar's worth of goods and services by 42 percent and that's without a comprehensive policy trying to do it. If we tried hard, we could go a lot farther than that even. But even with the results that we have, that makes energy efficiency the largest single source of new energy supplied for the Nation since 1973. Energy efficiency has been achieved primarily by three policies implemented at the State, regional and national level. Those have been: efficiency standards, which work best when they are performance-based rather than command and control; targeted incentives; and education and outreach. But these policies alone, even if they were pursued consistently, would not be enough. New innovative ideas are hard for consumers to find in the marketplace,

almost by definition, and they cannot easily achieve market success by the kinds of programs that we have used in the past. That is why the incentives in your bill, Mr. Chairman, S. 207 are so critical.

S. 207 addresses energy use in buildings. Buildings are an often overlooked large source of energy cost and energy demand. They account for about one-third of energy use and one-third of pollution and about one-half of energy costs, which is substantially more than automobiles. Energy use in buildings can be cut by half or more using technologies that are available today, at least to consumers who want to look for them.

How can we get them into the market in a serious way so consumers don't have to look, but they are the standard product?

We believe that S. 207 does this by providing national, uniform performance targets for building and equipment that will be in effect for a full 6 years. This is what manufacturers have asked for, and this is what has worked when utilities and Government have collaborated across the Nation to bring new technology into the marketplace. This bill builds on successful experience in utility and Government programs for refrigerators, clothes washers, fluorescent lighting systems and in energy efficiency codes for new buildings.

Let me end with a couple of particular issues where S. 207 is virtually the only game in town that can make a difference with critical energy problems. Those are the problems of electric reliability and high heating prices for natural gas and oil.

New Hampshire, as well, not just the West, is facing the risk of blackouts and/or high electricity prices this summer. There are a number of ways that you can try to alleviate the problem on the demand side as well as the supply side, but most of those have lead times such that they are not going to help this summer and they are not going to help next summer.

The things that can have an effect quickly are incentives for products that already exist, but are not mass-produced; because there, the lead time is just a factory taking something they know how to build and gearing up production. That is a matter of months, and not years.

Targeted incentives for air conditioners, where, as the gentleman said, you can save 30 percent of peak power with products now available and the product turns over every 18 years, that's one of the key areas, because air conditioning is 30 percent of peak load typically.

Efficient lighting systems, these are replaced every 10 years or so when buildings are remodeled. The lead time for design and replacement is a matter of months and not years.

Gas water heaters can be made much more energy efficient with, again, products that currently exist. All we need to do is make them mass produced rather than individually produced which has been the response to incentive programs in the past.

So, in summary, quick acting incentives such as those in S. 207 can help consumers both by giving them opportunities to reduce their own energy bills that aren't practically available right now and by changing the balance between supply and demand can reduce prices for everybody else.



So, we believe your bill fills a critical gap in energy policy for uses affecting one-third of the Nation's energy.

Thank you Mr. Chairman.

Senator SMITH. Thank you very much for your kind remarks.

I will ask a couple of tough questions about my own bill in a minute. Things that I have heard.

[Laughter].

Senator SMITH. Dr. Kelly.

**STATEMENT OF TOM KELLY, DIRECTOR, OFFICE OF SUSTAINABILITY, UNIVERSITY OF NEW HAMPSHIRE, DURHAM, NH**

Dr. KELLY. That's fine, thank you.

Good afternoon Senator and I greatly appreciate the opportunity to testify today. I do want to say a word of thanks to the members of my office and staff who have worked so hard with your staff as well too, to put the meeting together today.

You may recall I last spoke to you last fall in a meeting in New Hampshire with the focus on biotechnology and agriculture. I want to say that today as then, I speak to you not as an expert on any particular technology, but as an educator charged with integrating sustainability, the principles and practices of sustainability into all aspects of the University and I think education is a critical piece of this discussion and I am very honored to be part of it.

I would like to be with a scenario if I could. The year is 2030, world population stands at 12 billion with wide gaps between rich and poor countries and populations within countries.

Senator SMITH. Billion?

Mr. KELLY. Billion—sorry did I say million? I meant billion.

Senator SMITH. I wish it were million.

Mr. KELLY. The 20th assessment of the Intergovernmental Panel on Climate Change, an international scientific effort involving thousands of scientists from around the world, has established 93 percent certainty that human activities are driving rapid climate change. The U.S. Senate, which has not yet instituted any significant campaign finance reform, has called for more studies saying it needed 100 percent certainty before taking any action.

Senator SMITH. We are real good at calling studies, I think.

Mr. KELLY. U.S. national security is under constant threat due to its ongoing role in militarization of the Middle East linked to oil dependency as well as failure to support genuine human rights of all people in the region and the United States continues to import close to up to 60 percent of its energy fuels.

A national asthma epidemic linked to ozone pollution and other air quality problems has deepened as has public health risks from the vector-borne infectious disease such as West Nile Virus that are linked to ecological disruption resulting from sprawl and pronounced climate variability.

In 2030, the U.S. Senate Environment and Public Works Committee is holding a hearing on Innovative Environmental Technology—

Senator SMITH. And Bob Smith is the chairman—

[Laughter.]

Mr. KELLY. The committee is chaired by New Hampshire's new Senator Sununu.

[Laughter.]

Senator SMITH. OK, if it's 2030, that's OK.

Mr. KELLY [continuing]. Grandson of former Governor John Sununu and I should say parenthetically, the first generation of the Sununu family ever to be elected to the U.S. Senate.

[Laughter.]

Mr. KELLY. The hearing is being held at the University of New Hampshire, which has now been privatized though it has retained the name for branding purposes. UNH classes run until 5 p.m., while in the evenings the campus is used as a gambling casino—

[Laughter.]

Mr. KELLY [continuing]. To finance energy costs and K-12 education. The purpose of the hearing is to look at energy technologies that promise to sell the country's energy dependency and related environmental and economic challenges. The featured technologies include solar, wind and wave.

An undergraduate student, majoring in American History is attending the hearing and asks the committee chairperson, "How is it possible that we are still talking about the promise of these technologies rather than their accomplishments? We had these same discussions in the 1970s and again in the first decade of this century and we are still subsidizing fossil fuel and nuclear power."

Senator, the premise of my argument today is that the key link between technological potential and sustainability is education and governments or legislation. If we as educators, and you as legislators do your job, then we can indeed be looking back from the year 2030 on a shift to a solar or zero emission economy defined by a genuine entrepreneurial spirit emerging from a culture of democratic decisionmaking that all took place in the first decade of the 21st century.

From a perspective as an educator of environmental technology, we must shift the focus of our deliberations from consumer choice, efficiency, business and the economy to citizen participation, justice, governments and the polity. The economy is a subset of the polity, not the other way around.

It is important to remember that the most powerful effective force for sustaining the environmental foundation of human health and well-being in the epic of the oil shocks was not business technology or the economy. The national environmental policy acts, clean air act, clean water acts among many others, resulted from engaged citizenship, not consumer choice. And this engaged citizenship was concern at the knowledge of science and its moral application. Twenty-five years later, we have the luxury of questioning the continued effectiveness of such legislation, but only because it was successful.

I want to offer some concrete examples of how education and legislation can work together to ensure that schools and university campuses are brimming with alternatives to reckless consumption levels of nonrenewable energy. Such a learning environment will advance the goal of balancing economic viability with ecological health and human well-being for current and future generations through innovative educational initiatives related to energy and technology.

A few quick points on education. One of the fundamental jobs of education is to develop a historical consciousness or sense of history in all learners. The civic importance of this aspect of education's job is etched in stone on the face of the National Archives: "What is Past is Prologue." There are at least two ways to interpret this phrase. One is practical advice that individuals and institutions will act in the future as they have in the past. As an educator, I also view it as the kind of warning and expression of hope given to us by the philosopher George Santayana who said "those who ignore the past are condemned to repeat it." Santayana's guidance is full of possibilities because it proceeds from the premise that human beings have the ability to learn, which means the ability to distinguish good from evil and right from wrong in pursuit of the common good and to act on those judgments.

The fruit of the efforts of 1970s in renewable energy are well documented and it is important to review carefully that history unless we want to be here in 2030 asking the same questions.

A sense of history for sustainability includes people and places. We had an event right here on our campus and in this town of Durham some 25 years ago, known as the "Battle of Durham." Because of engaged citizens, again, not satisfied consumers, we today enjoy the Great Bay Estuary, one of the most unique estuarine habitats in the world that provides invaluable ecological services and a serene beauty that defines our sense of place. Were it not for the efforts of those citizens, we might have had one of the world's largest oil refineries rather than a preserve, protected with the help of Federal legislation.

But, notwithstanding that victory and the wonderful legacy of the Great Bay Estuary, there is a great deal of work left to do. If UNH in Durham and New Hampshire and other communities fill the tempting appetite for nonrenewable energy, then the body of Durham will have turned out to be a form of "not in my back yard."

The University of New Hampshire established our office in 1997 to work with all parts of the university, which we are doing to help ensure that graduates in all fields have the knowledge and skills to advance sustainability in their professional and civic lives. Project areas include initiatives in climate education; biodiversity education; food and society and culture and sustainability.

Climate Education Initiative, which relates most directly to today's hearing, includes projects addressing global change, transportation, energy, sustainable building design and construction. I won't go into the details of those because I know that I am running a little bit over.

I do want to point out one activity which I have appended to my written submission and that is, we have just completed, a week ago, as part of a partnership of a Portsmouth-based, non-profit Clean Air Cool Planet, the University of New Hampshire Durham campus greenhouse gas emission inventory, it's the first of its kind in the Nation and it will be shared with universities and communities around New Hampshire and the region. It will also serve as the basis for policy to develop emissions reductions.

I began the testimony with the assumption that the key link between technology potential and sustainability is education and government. Based on our work here, I would like to offer some spe-

cific examples of initiatives on this campus that could be supported through legislation that would make a significant contribution to our educational mission. These examples integrate innovative environmental technology into a learning environment where direct experience can be gained by students, faculty and all members of the university community. I will just quickly go through a couple of examples.

One, UNH is looking at the possibility of a co-generation plan and it would be an ideal opportunity to put in a 1 megawatt fuel cell along gas turbines so that students from engineering economics, as well as undergraduate policy students, could compare and contrast and research the benefits of that technology.

A community alternative energy assessment is another project that we would like to see move forward that will identify high impact opportunities for employing a wide range of technologies to enhance energy efficiency. Examples include: co-generation, methane digesters, ice storage, fuel cells and geothermal among others. Special consideration will be given to passive and active solar applications to address the structural disincentives that continue to retard the development of this crucial energy source for sustainability.

We have figured a way of transportation, looking at alternative fuel vehicles, buses, a fleet upgrade of our university fleet and alternative fuel vehicle cars for a car sharing program.

Related to agriculture, we also are looking at methane digester as a way to manage the nutrient loads that can also be used for study by engineering and other students.

One other idea that we have talked about is how we can provide more support to a school building program and integrate sustainable building design and construction standards and knowledge into schools—and some point in which we could do that through a filter or some other kind of mechanism would be quite important.

In conclusion, I would like to emphasize that technological potential and particular technologies are only part of the solution to the problem we face. Our role as educators is to ensure that the full knowledge we have and develop of our concrete and complex world is applied to the judgments and actions we take in all areas of public life.

Again, I would like to express my thanks Senator for the opportunity to contribute to this discussion. Thank you.

Senator SMITH. Well thank you very much for your testimony. A little suggestion, it might be fun to put the first part of that in a time capsule and see how it turns out. Hopefully, you are not related to Nostradamus and you will be wrong on some of those things.

Mr. Andary.

**STATEMENT OF CASIMER ANDARY, DIRECTOR, MOBILE SOURCE AFFAIRS, ALLIANCE OF AUTOMOBILE MANUFACTURERS**

Mr. ANDARY. Good afternoon. My name is Cass Andary. I am director of Regulatory Programs at the Alliance of Automobile Manufacturers. The Alliance is a trade association of 13 automobile manufacturers representing over 90 percent of the U.S. vehicle sales.

The auto industry in the United States is proud not only of its contributions to advanced technology, but also to its contributions to the U.S. economy. In a recent report, researchers associated with the University of Michigan concluded that the automotive industry produces a higher level of output in the United States than any other single industry. Notably, U.S. motor vehicle output represented 3.7 percent of the U.S. gross domestic product in 1999. Many of the jobs provided by the industry are high skilled jobs paying well above industry average. The average job in the automotive manufacturing sector was compensated at a level 73 percent higher than the average U.S. job.

In New Hampshire, more than 4 percent of the State's workforce is employed in either the automobile industry or in a job dependent on the auto industry. The automotive industry directly employs 4,400 workers and when related jobs and spin-off is included, a total of 27,300 New Hampshire jobs are dependent on the auto industry. The auto industry generates \$900 million in wages and benefits, including the spin-off employment in New Hampshire.

Member companies of the Alliance have invested billions of dollars in research and development. These companies are working to bring cutting-edge technologies, alternative fuels, advanced lean-burn engines, hybrid electric, battery electric and fuel cell vehicles to the marketplace.

The challenges to bringing the cars of the future to consumers are significant. The cost of advanced technology vehicles is considerably higher than the same vehicles powered by conventional combustion engines and consumers want technologies that they understand and that provide the comfort, safety and convenience to which they have grown accustomed.

Let me talk a bit about the new types of vehicles that the industry is busy working on today. The industry has long been active in exploring alternative fuels. Manufacturers make vehicles available that run on compressed natural gas, liquid propane gas and others that run on gasoline, a mixture of fuel containing 85 percent ethanol or some combination of gasoline and ethanol.

Advanced lean-burn engines, including direct-injection gasoline and diesel engines are being developed. These engines hold out the promise of providing a dramatic increase in fuel economy while emitting very low levels of hydrocarbon, CO and CO<sub>2</sub>. While somewhat higher levels of NO<sub>x</sub> and particulate matter have historically presented a technological challenge for lean-burn engines, advancements in engine design and exhaust gas aftertreatment can be expected in the near future. It should be noted that to realize the full benefit of these technologies, the availability of low sulfur fuels is necessary.

A new technology that has recently appeared on the market is the hybrid-electric vehicle. Both Toyota and Honda have a vehicle selling today, and Ford, GM and Daimler/Chrysler have vehicles read to introduce in the next few years. This technology combines both a traditional engine with electric motors and a small battery pack giving the vehicle two sources of power. Sophisticated computer control logic shuts off the engine when possible, letting the vehicle run an electric motor and then restarts the engine when needed.

We have also invested a tremendous amount of time and money in battery-powered electric vehicles. Battery-electric vehicles are not mainstream vehicles that would replace today's gasoline-fueled vehicle, but there may be market niches where some of the smaller battery electric vehicles can be sold.

The entire industry is working feverishly to develop commercially viable vehicles powered by fuel cells. Fuel cells have been used in the space program since the 1960s. The industry is working hard to reduce the cost of the fuel cell while improving its performance so there can be an alternative to the traditional gasoline fueled engine we have today. Hydrogen powered fuel cells offer the promise of a zero emission vehicle that can also meet all other customer needs and expectations. Many manufacturers are part of the California Fuel Cell Partnership, along with key suppliers, the California Air Resources Board, Department of Energy and Department of Transportation. This partnership is working hard to commercialize fuel cell vehicles and the necessary fueling infrastructure.

This industry is committed to continuing to push technology even further year by year, constantly improving the product while continuing to meet the transportation needs of the public. We believe further that pursuing these goals should lead to consideration of more broadly defined programs. All energy users and producers should be integrated in a comprehensive national energy strategy to achieve fuel savings with economic efficiency.

In addition, we believe that the costs of more expensive technologies are a hurdle to market acceptance. In order to expand the use of these advanced technologies, tax credits and incentives for advanced technology vehicles, including vehicles which demonstrate significantly higher efficiencies are necessary. Such incentives will speed acceptance and promote market forces that will make advanced technologies less cost prohibitive.

Finally, we observe that as all industries, both capital and human resources are finite, and are most efficiently deployed in response to market forces. Commitment schedules for capital spending, vehicle model renewals and powertrain longevity can range from 5 to 10-plus years. Over the past 10 years, the industry has demonstrated that when resources can be shifted from continual incremental regulatory compliance pressures, the industry can and will undertake major research and development programs aimed at significant long-term energy efficiency. Clear examples are the development of hybrid electric powertrains and the continuing investment in the fuel cell systems.

The Alliance firmly believes that the advanced technology vehicles that are reaching the marketplace, or are under development, offer the greatest promise for the future. These are or will be clean, highly fuel efficient vehicles, but many consumers will be understandably hesitant to try these new and more expensive technologies. Incentives that encourage consumers to purchase advanced technology vehicles can help accelerate the number of fuel efficient vehicles on our roads, without sacrificing the safety, comfort, utility, carrying capacity and performance that consumers want.

Thank you for the opportunity to speak today.  
Senator SMITH. Thank you Mr. Andary.

Just a quick question to each of you and then we will open it up. When you think of the fuel efficiency—let's just go to a hydrogen vehicle—skip the hybrid and go to the hydrogen for a moment as a fuel cell vehicle. The efficiency there is so incredible, do we have a technological problem here or a market problem?

Mr. ANDARY. I think we probably have a little bit of both.

Senator SMITH. Not for the hybrid though, but for the hydrogen.

Mr. ANDARY. First off, there isn't infrastructure in place to deliver the hydrogen, I don't believe.

Senator SMITH. So we need more education?

Mr. ANDARY. Some. We need infrastructure, we need the capacity to build, there are a whole host of things besides the market forces that will want to make people buy those cars.

Senator SMITH. See, I think it is an educational problem as well and I think that is where schools and universities throughout the country can play a big role in it. Because, there is clearly an infrastructure lacking for this so we need to talk about it. I don't pretend to be an expert on this, there are many people who know more about it than I do right here on this stage, but as I have spent the last year-and-a-half looking into this, you realize that the ramifications are so huge. Every time I talk about it, and as one who is a conservative Republican who is not supposed to care about these issues, I find it very interesting because one always says "Well, it's not just a consumption problem." But when you have the opportunity to make these kinds of inroads into the consumption of the fuel that we use, the results are dramatic. When you look at the emissions and you look at the energy consumption and where we get that energy—and a lot has been made of my position on the Arctic National Wildlife Refuge—however, the need for the Arctic Wildlife Refuge oil goes away completely and then some by a long shot if you produce these automobiles. So, I think we just have to recognize you can't expect the automobile manufacturers to put cars out on the road that nobody is going to buy. But what we can do, is start through the education process to get people to understand that at least at the hybrid level, we can produce hybrid cars much like a golf cart. I mean, it's the same concept as you take the foot off the pedal in a golf cart and you stop, the engine shuts off and that's what you do a lot when you are sitting in traffic, so why burn gasoline?

So, I think it is an infrastructure issue and I think we need to do more and I intend to do as much as I can, which is why we have hearings like this that get all over the country so we can draw attention to it.

Let me ask you Dr. Kelly, you mentioned some of these initiatives. Speaking of infrastructure, would we be able to have this kind of technology here on campus? Would UNH acquiesce to letting students study these programs? Would we have the infrastructure here to produce students who would come out and go into these technologies?

Mr. KELLY. I think there is no question that UNH would welcome.

Senator SMITH. I meant, when I say UNH, I mean colleges in general.

Mr. KELLY. Well, I think the question of higher education reform is very critical to this. By example, there was an interesting story recently in the *Boston Globe* about architecture and award winning architects that are designing buildings in the Boston area and Harvard University among others. It was saying that they really wanted to send a message that they were not conservative and not business as usual by having this architect build a very non-traditional building, but they didn't say anything about how they structure their departments. They didn't say anything about their own energy practices. They didn't say anything about undergraduate education and the liberal arts foundation that is required to reason your way as a citizen through these issues.

So, I think at UNH we have got a commitment to that and we are underway. I think there are various levels of commitment across the university landscape, but they are very conservative institutions and change comes slowly and hard.

Senator SMITH. I think that's always the way. I mean, when the kids graduate from the colleges and high schools, is there employment out there and which comes first? So it is a tough issue. But, I think it's one we should focus on. Because, I think as part of an energy policy, one of the things that is very frustrating to me as a legislator, not a technical expert, but one that has to act or react to pass good legislation, you have the short-term problem of fuel shortage or a power problem, whatever it may be, or high costs. That is a short-term problem and when you start talking about hydrogen cars or solar energy taking care of all the needs, whatever, then it doesn't cut it with the person sitting there paying three bucks at the pump or breathing too many fumes. So, we have to have a two-pronged approach here. And that's why we are trying to get that debate started.

I hope that when the energy policy that the President has put out is finally adopted and appropriate changes are made that we do just that. That it is a two-pronged approach and that deals with today as well as tomorrow.

Mr. KELLY. Just one follow-up comment. One way that we can bring the short-term and the long-term together I think is, as I indicated in my testimony, if we look at alternative fuel vehicles, introduce them into the community in a car sharing program, then we are looking at the kinds of institutional practices or approaches that really get at the problems we have. If we simply replace one for one each single occupancy vehicle that is currently burning gasoline with electric or hybrid cars, we still have the congestion, we still have the sprawl which drives land-use changes which undermine our community sustainability. So, I think putting that technology in the context of transportation to man management for example, can be a power educational approach.

Senator SMITH. I think you are right about that. One final point that I have neglected to mention was that there is an interesting statistic regarding cars and trucks. Cars and trucks are 96 percent cleaner than their counterparts of 30 years ago and the vehicles of 2009 will be 80 percent cleaner than today's cars. So, the magnitude of what we are talking about here is huge and I think we need to start talking about infrastructure so we don't put the cart ahead of the horse.



Mr. Goldstein, you were kind enough to talk about my legislation and I appreciate it. There is some criticism saying that this is very complicated and you know, how are we going to implement all these tax credits and tax incentives to put insulation in or do this or do that. Is it really that complicated?

Mr. GOLDSTEIN. No, it's actually very easy, Mr. Chairman. I spent a lot of time working with you staff and committee staff on getting the technical details right, which means doing something that already has a track record of having worked. So, you try something and it doesn't work and you make it a little bit more complicated and maybe it works a little bit better. We have taken the finished product from that and asked the Department of Energy to model their procedures for qualifying for the tax incentives on the things that have worked in California and Florida and other States here in New England and they are very easy to do.

One of the roots of this bill was some work that the previous Administration had done where the Treasury Department was commenting on some of that Administration's plans and their comments were to the extent of this is not very workable the way you've got it. We were able to work with the Treasury folks who were in charge of IRS to make sure that those kinks were beaten out of it and come up with something that's going to be very simple for the taxpayer and the energy consultants to provide third party verification to work with.

Senator SMITH. Where the rubber really hits the road though on this whole policy of energy is just where the break-off is—if Armageddon is tomorrow, or next year, or 10 years from now in terms that we are all going to suffocate to death from carbon monoxide or whatever, or heat ourselves to death. The thing is, I find generally—generally, not always—but when you are talking to the group who are very much in favor of renewable energy and conservation, they tend to be exclusive and not interested in nuclear power or any other options: clean coal, whatever else you want to talk about. I guess the same is true with the other side, you will get those who are: more power, more oil, more gas, more coal, more nuclear and that other stuff is a bunch of nonsense. It seems to me that it has to be in the middle somewhere and if we only knew what the future holds in terms of how much time we had, how much time do we have before we need to move totally away from these carbon emissions, it would be a lot easier. But, from a legislator's point of view, it's tough, I mean, you just don't know. There is a lot of science that we just don't know. So, that's what we are faced with. But, I am really delighted that we are debating energy and an environmental policy throughout the country now, because they go hand in hand. So, I am excited about that.

Could I just have a show of hands of anybody who wants to ask a question. That would help me a little bit in terms of—one, two, three—OK, four or five people, good. I have a couple of names on here, somebody just take the ones I have and if the other panel would like to come up and Chris Hessler can give you the mike. But the other panel can maybe come up here and if we got some chairs here, I can stand up and let you all sit here.

Don Gray.

Mr. GRAY. I can just give you a written question.

Senator SMITH. OK, great.

How about John Moses? John? Just direct your question to whoever you would like to ask it to and keep it brief.

#### **STATEMENT OF JOHN MOSES, CF TECHNOLOGIES**

Mr. MOSES. Good afternoon, Senator. Actually, I just would like to take the opportunity to thank you for being able to come here and make a few comments. I would just like to direct some comments to you.

I am John Moses. I am with CF Technologies. We are developers of critical fluid technology. It's technology based on the use of carbon dioxide and other gases under pressure. It is environmentally clean solvents.

Among the energy and environmentally-related uses of the technology we have developed: an oil absorbent recycling, windshield polymer recycling, chemical agent destruction and decontamination, Dynapel cleanup, oil drill cuttings cleanup, and we hope to demonstrate in New Hampshire.

We hope to demonstrate that Dynapel clean-up technology here in New Hampshire later this summer. It is technology that we developed with our international labs. Our oil absorbent recycling technology has the potential to keep 100 million gallons of waste oils out of landfills and at the same time to put that oil back into lubricants and fuels. The application was commercialized 3 years ago, it grows slowly, has about 600 customers for one plant that is in the Midwest. Right now it's operating at a rate where it's recycling about 50,000 gallons of oil per year, just really a drop in the bucket of those 100 million gallons.

We would like to see technologies like these go commercial faster. We think the Federal Government can help. We believe some of these applications that I have said, as well as there are many other applications of innovative technologies for energy and the environment that can have a positive impact on this country's energy and environment. As some of the others have already stated, there need to be reductions in the economic market and regulatory barriers to introducing new technologies. And, when you're putting in new technologies, new markets, new products and trying to compete with high volume products, it's typically difficult. The economic barriers are there and certainly incentives such as tax credits in the early stages would speed up the acceptance of new technology. Also, to help with the acceptance, if the Government used the technologies themselves: for example, the Department of Defense is a huge energy user. That would certainly help. We look forward to participating in things like the environmental technology verification programs and expect that that will help with regulatory issues and things like that. Thank you again Senator.

Senator SMITH. Look, thank you very much Mr. Moses for your remarks. While whoever the next questioner is that comes up, I would just say that one of the things that is different now that has not been the case in the past several decades, is that we are, at least now and hopefully it will continue, running surpluses at the Federal Government level. However you feel about the tax cuts or whatever, the debt is being reduced, the tax dollars are coming back to the people, but also we now have money, or will have in

the very, very near future as we move out into the out years here to deal with some of these environmental needs: infrastructure, water and sewer. For example: infrastructure, which is a huge problem, probably a trillion dollar problem in America today and not to mention all these technologies and almost everyone mentioned some Government help, perhaps in the form of tax credits or whatever, and I think it's doable now. I think we need to sell it, you know, we do pick winners and losers when we do it, and that's the bad part but—and I think that's what Solar's point is—that they have been the loser in terms of getting the tax help that others have gotten. So, we need an education process here to put some of these dollars, as we put them back, bring them back to you, we can bring them back in the form of environmental help which is what we are doing here with UNH. With a lot of the things that they are doing a great job in research and putting students right out in the field, especially some of these water and air issues. So, it's been a great partnership.

Is there another question over there?

Yes sir, if you would just identify yourself for the record, please.

#### **STATEMENT OF DAVID FUNK, GREAT BAY STEWARDS**

Mr. FUNK. I am David Funk with The Great Bay Stewards.

Dr. Kelly, you referred to a sustainable school design program. Why shouldn't this sort of thinking be extended to the design of all public buildings?

Mr. KELLY. I'm sorry?

Mr. FUNK. Public buildings.

Mr. KELLY. The reason it shouldn't, the idea there was to try to make the educational link so that universities would be linked with K-12 schools and to incorporate the sustainable design and practices and then make that part of the curriculum, which is what we are trying to do here at UNH. So, that was the only reason that I limited that idea to schools. You are absolutely right, it could apply to all public buildings.

Senator SMITH. Any further questions?

#### **STATEMENT OF JOSHUA WILSON**

Mr. WILSON. Well, I want to thank you for hosting this and I am afraid I am going to have to put you on the spot, Senator.

Senator SMITH. I have been there before.

Mr. WILSON. Good. I am really confused about the Bush Administration's energy plan and something that Mr. Eidlin said and I think he was very polite about it. It was that the National Renewable Energy Lab has been disfunded and I would like both of you to answer this question if possible. I would like to know why the funding has been removed from this in a time when we obviously need to be exploring alternative energy. So, if you could explain. Oh, I'm sorry, my name is Joshua Wilson for the record.

Senator SMITH. Did you want to respond Richard or did you want me to? Go ahead.

Mr. EIDLIN. I don't think I really have a clear explanation for why that is being cut. Renewable Energy Lab's budget is very modest, I think it's \$17 to \$25 million, it was. So, it's an extremely insignificant amount of money in the scope of Federal R&D for any

energy technologies. So, I can't really give you a good explanation for why it's cut, but it certainly has, in the past, made significant contributions to technology development and commercialization.

Senator SMITH. I might just say in the budget that has been sent here by the Administration, it has been cut, but the budget hasn't passed yet so it's always the way—it's the President's budget—whoever the President is, there are always things in there that the Congress disagrees with in priority. But, I hear your question and I am going to take that information back and look into it.

I think what happens with these kinds of things is that we see, again I use the terms winners and losers, but that's pretty much what it is. It just basically is in the mind of the eyes of the beholder, you know, what's important and what isn't and that's where it gets tough. That's why I'm hoping that we can see more dollars directed—frankly, I'm an R&D guy, always have been. I think that when you eat your seed corn, you're never going to grow any corn and I don't care what you are talking about, you talk about defense, you can talk about environment, technology, whatever it is, you should not—every time we have tight budgets we cut R&D money. They always criticize the R&D accounts, because for every—well I don't know, maybe somebody knows the numbers, but for every let's just say 100 things you try to do successfully, you do one or two successfully and the rest looks like wasted money, but when in fact, it's research and it's valuable research.

I always use the cancer example. We haven't found a cure for cancer yet, but I certainly wouldn't want to stop funding cancer research because we haven't found a cure. In fact, we ought to be upping that account as well if you want my personal opinion on that one.

So I am optimistic that that program may not be cut, but we will see. I can't make a commitment, because I am only one person. In fact, the way things have been going in Washington, I probably shouldn't make any commitments, but anyway, I'll take a look at that program specifically because you brought it up.

Mr. HESSLER. Senator, I think we have two more questions. One on this side and one on that side.

Senator SMITH. I would like to end it at that if possible and if you do have written questions and would like to submit them, I would be more than happy to take those questions.

**STATEMENT OF HON. DANIEL ITSE, NEW HAMPSHIRE  
STATE REPRESENTATIVE**

Mr. ITSE. Thank you Mr. Chairman. For the record my name is Dan Itse, I am a State Representative and president of Christopherson Engineering. I have questions for Judith Bayer and Mr. Eidlin, because their technologies excite me as a technologist and they have near-term application. And, for a reference point, for personal reasons, we have a 12,000 KW power system at our house.

Ms. Bayer, you stated that right now the cost of a fuel cell is about \$4,500 per kilowatt and that it operates in hydrogen. A lot of New Hampshire can't even get natural gas. How far away do you feel propane fuel is for a fuel cell? When do you think it could meet the \$1,000 per KW cost that is comparable to a reciprocating engine?

Second for Mr. Eidlin, what is the capital install cost for a solar system for comparison?

Ms. BAYER. In answer to your first question, as far as natural gas and propane, we currently run most of our PC 25 systems on natural gas. We also have the capability to run them on propane. So, the residential units that you are seeing for example, if you had a remote cabin somewhere and you wanted to run it off of propane because natural gas wasn't available, that's one of the designed features that is one of the areas that we think there is some real potential for the early adopters of this technology. You can run a fuel cell off of any hydrocarbon, mostly because you don't have hydrogen available in its' pure form. We run them off of, as I said, natural gas, propane. We have run them off of methane from anaerobic digester gas systems. We have run them off methane from landfills and we have also run them—we have the technology to run them on pure hydrogen. We have a facility in an installation in Germany where there is hydrogen available at a chemical plant and they use that directly in the system. If you had hydrogen available, you could eliminate what we call the fuel processing steps in the process and go directly to the zero emission power generating stations that we all envision in the future.

As to your question as to when we will reach the magic \$1,000 level, that really depends on volume. It depends on how quickly the market accepts the technology and how quickly the volume builds so that we can get those costs down. We would hope for the residential units that we could bring those costs down by the year 2005 and in that range.

Mr. EIDLIN. The per kilowatt cost of a solar today is about 22 cents. In New Hampshire, we pay 14 or 15 cents per kilowatt. In some places in the country, they pay more than that. So it is comparatively more expensive in most cases than conventional fossil fuel, but if one takes into account the exogenous externalities of air pollution, delivery costs, etc., one will find likely that it's a very similar cost. In similar applications, solar technologies are cheaper than conventional fossil fuel. A good example of that is a system we installed on Block Island in Rhode Island for the U.S. Postal Service where, because they were reliant on unreliable diesel generators and they were bringing their power from the mainland, they were paying about 31 cents per kilowatt hour. So they made a strategic choice to save themselves a lot of money and they also got a reliable power source so that their equipment, their mail processing equipment, cash registers and other items weren't having to be replaced every 2 years. So, the system we have in our house in Amherst is about a 3,000 watt system and we say it's affordable, we never say it's expensive. So it was affordable to the tune of in the low \$20,000 range. But again, I just point out that because of net metering, you can sell power back to the utility in many States at the retail cost, so on a day like today, our meter was spinning backwards for—probably from 9 o'clock in the morning until mid-afternoon, which improves economics.

Senator SMITH. Final question.

**STATEMENT OF JOHN HODSDON, MEREDITH, NH**

Mr. HODSDON. Thank you Senator Smith. John Hodsdon from Meredith, NH, a farmer.

I have a question for Mr. Andary. Thirty years ago, we were all told that gas turbine automobiles were the cars of the future, because of the high efficiency and low pollution. What happened in that and is there a lesson from what happened that we should be considering now?

Mr. ANDARY. I would like to know who told you that. Gas turbines are—although I believe in the last 30 years there has been a lot of work done on the burner technology. They use a lot of air and in order to reduce emissions, you need to run the vehicles basically at stoichiometric unless you have some very advanced technologies to go along with that. So, if you do the mathematics, for every pound of fuel that you burn, you have to have 14 pounds of air, or thereabouts. That makes a lot of unburned fuel, carbon monoxide, a lot of mass of those pollutants. As a result, you end up with something that's not very fuel efficient, especially in non-steady States where you have city traffic, stop and go. It works all right for airplanes because the power generation is there, but not so much for cars.

Does that answer your question?

Mr. HODSDON. What about other new technologies like those we heard about today?

Mr. ANDARY. I think that the industry has learned from that and there is an investment. We do a lot more work into those new technologies now before we release them to the market.

Senator SMITH. Thank you. Thank you very much.

Let me also say thank you to the University of New Hampshire for their splendid cooperation here.

[Applause].

Also to thank all of the witnesses and also those who displayed their technology. If you haven't had a chance to look both inside and outside, it's well worth seeing.

If anyone has a written question or comment that they would like to be made part of the record, if you would get it to us by the end of the week, I will see to it that it goes into the record. You can fax it to us or you can e-mail it to us by the close of business on Friday. I will get it into the record and you can be famous.

Thank you again. I do know one thing, I think that maybe 60 years from now, Dr. Kelly when they look back on this hearing, I'll bet you that most, if not all of the technologies that we talked about will be in full use and maybe they might even be outdated by then, who knows?

Thank you all.

[Whereupon, at 4 p.m., the hearing was adjourned.]

[Additional statements submitted for the record follow:]

STATEMENT OF FRANK ALIX, CHAIRMAN AND CHIEF EXECUTIVE OFFICER OF  
POWERSPAN CORP.

Chairman Smith and distinguished Members of the Senate Committee on Environment and Public Works, thank you for the opportunity to share Powerspan's perspective on innovative environmental technology and energy policy.

My name is Francis R. Alix and I am Chairman and Chief Executive Officer of Powerspan Corp.

Powerspan is an emerging energy technology company headquartered in New Durham, New Hampshire. Our company was founded in 1994 and has grown to employ 45 people, most in high paying technical jobs. In order to fund technology development, the company has raised over \$28 million to date from private, institutional, and corporate investors.

Over the past 3 years, Powerspan has focused its resources on the development and commercialization of a patented multi-pollutant control technology for coal-fired electric generating plants called Electro-Catalytic Oxidation™, or ECO. The ECO technology is designed to cost-effectively reduce emissions of sulfur dioxide (SO<sub>2</sub>), nitrogen oxides (NO<sub>x</sub>), mercury (Hg), and fine particles (PM<sub>2.5</sub>) in a single, compact system. Several leading power generators are investors in the company or partners in ECO development. These include FirstEnergy, American Electric Power, Cinergy and Allegheny Energy.

Powerspan has successfully tested the ECO technology in a 2-megawatt slipstream of a coal-fired plant owned by FirstEnergy. During this test, ECO reduced emissions of:

- Nitrogen oxides by 76 percent
- Sulfur dioxide by 44 percent
- Mercury by 81 percent
- Total particulate matter by 99.9 percent

The U.S. Department of Energy recently selected Powerspan for funding under a solicitation for promising mercury control technologies for coal-based power systems. In addition, lab testing of our second-generation ECO technology has demonstrated nitrogen oxide removal of more than 90 percent, and sulfur dioxide removal of more than 99 percent.

Powerspan has begun installation of the first commercial ECO demonstration in a 50-megawatt slipstream at FirstEnergy's Eastlake Plant near Cleveland, Ohio. The project is being co-funded by a \$3.5 million grant from the Ohio Coal Development Office within the Ohio Department of Development. Successful completion of this demonstration in 2002 will lead to the availability of full-scale commercial ECO systems beginning in 2004.

As you consider the important role that innovative technology can play in further enhancing the environment, I would like to make the following points:

1. Environmental technology development is driven almost exclusively by environmental regulations. Regulatory certainty and time are important factors that impact the degree of environmental technology deployment.
2. The cost of achieving environmental compliance is usually significantly less than estimated at the time regulations are developed.
3. Environmental regulations are not all created equal. Some are more likely to spur innovation than others.

Let me briefly address each of these points.

- Both the electric generating industry and the environmental technology community rely upon long-term certainty in environmental regulation. For the capital-intensive electric generating industry, long-term regulatory certainty allows for the orderly improvement of generating assets without undue financial risk or threat to the availability of electricity supplies. For the technology community, regulatory certainty provides the incentive and time to deploy resources to develop and commercialize new technology that will meet the regulatory goals in the most cost effective manner possible.

- In the process of crafting environmental legislation, the cost associated with the law's implementation is normally evaluated. These cost assessments are inevitably based upon what is known or commercially proven at the time. The objective of technology developers, however, is to make what is known and commercially proven obsolete. This they do on a regular and dependable basis. Therefore, it is important to remember that, given time, technology developers will ensure that environmental compliance costs are far less than predicted today.

- The ECO technology could provide the environmental benefits of reductions in a number of air emissions, including mercury, years ahead of a typical regulatory schedule, and at a lower cost than conventional pollution control technologies. However, the existing regulatory requirements significantly limit the generating industry's compliance flexibility, thereby making the use of multi-pollutant approaches less viable.

Under the current interpretation of best available control technology—or BACT—generating utilities could not use ECO technology to help achieve NO<sub>x</sub> or SO<sub>2</sub> reductions, even if it were almost as effective as the best available technology, and simultaneously achieved reduction of other pollutants such as mercury. Yet, if ECO technology were deployed throughout the industry, far more emission reductions could be achieved than through selective BACT deployment. And the associated health

benefits would accrue to a larger percentage of the public. This kind of regulatory inflexibility doesn't make economic sense and, more important, doesn't make environmental sense.

Therefore, I support the President's National Energy Policy call for multi-pollutant legislation that will establish a flexible, market-based program to significantly reduce emissions of sulfur dioxide, nitrogen oxides, and mercury from electric power generating plants. I believe that Congress should determine the appropriate reduction requirements and timeframe to phase in reductions, and then allow industry to meet them in the most cost-effective manner possible. A command-and-control approach would only serve to drive up costs and curb innovation.

Although Powerspan is proud to have achieved our success to date without government funding, I also support the continued emphasis of Congress and the President on research and development funding for clean energy technology.

In summary, I believe that increasing our energy supply, and at the same time, improving our environment is not only possible, but also imperative for the future well being of our society. Fortunately, our Nation is blessed with an innovative and entrepreneurial spirit that will rise to such challenges. I believe political leaders must exercise a degree of faith in order to establish the environmental laws that look out over a decade or more to protect public health, when compliance uncertainty may exist. Given time and the right regulatory framework, the technology community will find an economical way to achieve the desired environmental benefits. History has demonstrated this time and again. And there are many companies like Powerspan full of talented individuals that are dedicated to this goal.

Thank you.

---

STATEMENT OF JUDITH ANN BAYER DIRECTOR, ENVIRONMENTAL GOVERNMENT  
AFFAIRS, UNITED TECHNOLOGIES CORPORATION

Good afternoon. My name is Judith Bayer. I'm the Director of Environmental Government Affairs for United Technologies Corporation (UTC). UTC is based in Hartford, Connecticut and provides a broad range of high-technology products and support services to the building systems and aerospace industries. Our products include Carrier air conditioners, Otis elevators and escalators, Pratt & Whitney jet engines, Sikorsky helicopters, Hamilton Sundstrand aerospace systems and fuel cells by International Fuel Cells.

UTC spends an average of \$1 billion per year on research and development. Our corporate environment, health and safety policy includes commitments to: conserve natural resources in the design, manufacture, use and disposal of products and the delivery of services and develop technologies and methods to assure safe workplaces and to protect the environment worldwide. UTC has invested heavily in bringing clean, energy efficient technology to the global marketplace, and we need to continue to work closely with government policymakers to maximize the benefits of these innovative technologies.

While UTC's diverse portfolio offers a number of examples of clean, energy efficient technologies, I will focus today on technologies and products from our International Fuel Cell (IFC) and Carrier units. I will describe some of our fuel cell and air conditioning products and activities, their applications and benefits. In addition, my testimony will provide some suggestions regarding government actions that will help to maximize these benefits and improve air quality, protect the ozone layer, avoid man-made greenhouse gas emissions, reduce dependence on foreign oil, provide reliable power as well as reduce electric utility peak load demand.

FUEL CELL DESCRIPTION

Fuel cells are the cleanest fossil-fuel generating technology available today. They use an electro chemical process to convert chemical energy directly from natural gas or other hydrogen rich fuel sources, into electricity and hot water at a very high level of efficiency.

REALITY OF FUEL CELLS

Fuel cells are not a futuristic dream. More than 250 U.S. astronauts have depended on UTC's fuel cell products to provide all the electrical power and drinking water used in every manned U.S. space mission. Each space shuttle mission carries three IFC 12 kW fuel cell units and we have accumulated more than 81,000 hours of fuel cell operating experience in the most demanding environment of all—outer space.



Closer to home, IFC has produced and sold more than 220 fuel cell systems in 15 countries on four continents. We're the only company in the world with a commercial fuel cell product available today. It's known as the PC25s and it produces 200 kW of power and 900,000 BTUs of heat. Each unit provides enough power for roughly 150 homes. The worldwide fleet of PC25s has accumulated more than 4 million hours of operating experience with proven reliability. The PC25 system requires only routine maintenance and has a life of 40,000 hours or 5 years.

#### ENVIRONMENTAL BENEFITS

Since fuel cells operate without combustion, they are virtually pollution free. In addition they produce significantly lower levels of carbon dioxide emissions—the primary man-made greenhouse gas contributing to climate change. For example, while the average fossil fuel generating station produces as much as 25 pounds of pollutants to generate 1,000 kilowatt-hours of electricity, the PC25 power plant produces less than an ounce.

The existing fleet of PC25s has already prevented nearly 800 million pounds of CO<sub>2</sub> emissions and more than 14.5 million pounds of NO<sub>x</sub> and SO<sub>x</sub> compared with typical U.S. combustion-based power plants. The U.S. Environmental Protection Agency recognized IFC last year with a Climate Protection Award in recognition of these accomplishments.

#### EFFICIENT SOURCE OF POWER

Fuel cells are inherently more efficient than combustion-based systems. In the "electricity-only" mode of operation, IFC's PC25 unit achieves approximately 40 percent efficiency. When the waste heat from the fuel cell is utilized, an efficiency of 87 percent can be achieved. In addition, fuel cells can be installed at the point of use, thus eliminating transmission line losses that can run as high as 15 percent.

#### MINIMAL IMPACT ON GRID

Fuel cells can provide power at the point of use, thereby alleviating the load on the existing transmission and distribution infrastructure, and eliminating or minimizing the need for additional investment in the current transmission and distribution network.

#### ENERGY SECURITY

The use of fuel cells helps to diversify the energy market and reduce reliance on imported oil. Fuel cells can operate with a variety of fuel sources, but most commonly use natural gas.

#### CONTINUOUS SOURCE OF BASE POWER

Unlike other environmentally favorable solutions, fuel cells can be used as a continuous source of base power—independent of time-of-day or weather—for critical facilities and power requirements.

#### IDEAL NEIGHBOR

Its compact size, quiet operation and near-zero emissions allow a fuel cell system such as the PC25 to be sited easily in communities and neighborhoods. Unlike many other forms of power generation, fuel cell power plants are good neighbors. For example, two PC25s are located inside the Conde Nast skyscraper at Four Times Square in New York City.

#### DISTRIBUTED GENERATION

Fuel cell power plants offer a solution when power is needed onsite, or when distribution line upgrades become cost-prohibitive and/or environmentally unattractive. For example, a PC25 installed at the Central Park Police Station in New York City provides all the power for the facility in an onsite installation. In this case, it would have been too expensive to dig up Central Park and install an additional power line, so the fuel cell became the ideal solution for an operation that required a dedicated, reliable power supply and flexible siting.

#### EMERGENCY POWER

Several hospitals in the United States, including Department of Defense facilities, rely on PC25 systems to provide on-line emergency power.

In Rhode Island, for example, a PC25 system provides power for the South County Hospital. The installation supplies base load electrical and thermal energy to the

hospital where it helps ensure clean, reliable power for sensitive medical equipment and systems such as CAT scanners, monitors, analyzers, and laboratory test equipment. If there is a grid outage, the PC25 automatically operates as an independent system, continuing to power critical loads at the hospital. Heat from the installation provides energy for space heating, increasing the fuel cell's overall efficiency.

#### GRID SUPPORT

The largest commercial fuel cell system in the world is currently operating at a U.S. Postal Service facility in Anchorage, Alaska. The system provides one megawatt of clean, reliable fuel cell power by joining five PC25 units. In this installation, the units operate in parallel to the grid and are owned and operated by the local utility. The system is seen as a single one-megawatt generation asset and is dispatched by the utility through its standard dispatch system. The system is designed so the fuel cells can either provide power to the U.S. Postal Service mail-processing center or provide power back to the grid. In case the grid fails, a near instantaneous switching system automatically disconnects the grid and allows the fuel cells to provide uninterrupted power.

#### ASSURED RELIABLE POWER

As our society increases its reliance on sophisticated computer systems, very short power interruptions can have profound economic consequences. In 1996 the Electric Power Research Institute reported that U.S. businesses lose \$29 billion annually from computer failures due to power outages and lost productivity.

PC25 power plants are currently delivering assured power at critical power sites such as military installations, hospitals, data processing centers, a U.S. Postal Service mail processing center and sites where sensitive manufacturing processes take place. One of IFC's installations at the First National Bank of Omaha where four fuel cells are the major component of an integrated assured power system, is meeting customer requirements for 99.9999 percent reliability. This translates into a power interruption of 1 minute every 6 years.

#### PARTIAL LOAD/CO-GENERATION

The Conde Nast Building at Four Times Square in New York City is a "green building" with two PC25 power plants installed inside to provide 5 percent of the building's electrical needs. If there is a blackout, the systems are capable of operating independent of the utility grid to maintain power to critical mechanical components and external landmark signage on the facade of the building. The waste heat from the unit is used to run the air conditioning and the power plants provide critical backup power in case the grid fails.

#### RENEWABLE ENERGY

When fueled by anaerobic digester gases or biogas from wastewater treatment facilities, fuel cells are a source of renewable power. IFC and the U.S. Environmental Protection Agency (EPA) collaborated in the early 1990s on a greenhouse gas mitigation program that continues to bear fruit today. Initial efforts targeted landfills and the development of gas cleanup systems that enable fuel cells to use waste methane to generate electricity and resulted in the issuance of several patents jointly held by EPA and IFC. These systems prevent methane—a potent greenhouse gas—from being released into the environment and avert the use of fossil fuels as the fuel source.

Follow-on work has focused on anaerobic digester off-gases (ADGs) from wastewater treatment facilities. This technology has been implemented successfully at PC25 installations in Yonkers, New York; Calabasas, California; Boston, Massachusetts, and Portland, Oregon as well as Cologne, Germany and Tokyo, Japan.

#### FLEXIBLE AND BROAD APPLICATION OF FUEL CELLS

The examples noted above demonstrate the flexibility of fuel cell technology and its appeal to many different customers with a wide range of requirements. But it gets better. Fuel cell technology and its associated benefits, which have broad application in the commercial/industrial sector, is also being developed for homes, small businesses, cars, trucks and buses.

#### RESIDENTIAL AND LIGHT COMMERCIAL FUEL CELL APPLICATION

IFC is currently pursuing residential and light commercial fuel cell applications for homes and businesses. These units will use next-generation proton exchange

membrane (PEM) fuel cell technology. We are drawing on our experience in both commercial and mobile fuel cell programs to develop a 5-kilowatt PEM fuel cell system suitable for homes and small commercial buildings. IFC is teaming up with its sister, UTC unit Carrier Corporation, the world's largest maker of air conditioners, as well as Toshiba Corporation and Buderus Heiztechnik on this effort.

We are currently testing our residential power plants and plan to have residential fuel cells units commercially available in 2003. We have a residential fuel cell model with us today in the exhibit area.

#### TRANSPORTATION FUEL CELL APPLICATIONS

In the transportation arena, IFC is aggressively developing quiet, highly efficient ambient-pressure PEM fuel cells and gasoline reformation technology for automobiles, heavy-duty trucks and bus applications. Fuel reforming technology allows fuel cells to operate on pump gasoline.

IFC is currently working with major automobile manufacturers, including BMW and Hyundai and with the U.S. Department of Energy on development and demonstration programs for automobiles.

Last year, for example, IFC replaced the internal combustion engine in a Hyundai Santa Fe Sport Utility Vehicle with its zero emission Series 300 75-kilowatt hydrogen powered fuel cell. This vehicle was featured at the grand opening ceremony of the California Fuel Cell Partnership on November 1, 2000. Pure water vapor is the only by-product of this fuel cell power system. Hyundai and IFC has put two fuel cell powered Santa Fe's into driving service in California and expect to provide another four in 2002-2003.

The IFC vehicle power plant is quiet and efficient. It's unique because it uses a near ambient pressure system, which substantially increases its efficiency. By eliminating the high-pressure requirements of other fuel cells, IFC has created a system with fewer parts, which translates into lower costs for the consumer. To date, we have demonstrated the following capabilities with the IFC/Hyundai Santa Fe fuel cell vehicle:

- Starts in less than 30 seconds;
- Performs with undetectable noise levels;
- Operates without any operator intervention;
- Achieves maximum power output of 75 kW and a top speed of 72 mph;
- Fills the vehicle's fuel tank with hydrogen to a pressure of roughly 3,000 psi in less than 3 minutes; and
- Avoids any loss of passenger or cargo space.

In addition, we've also developed fuel cell auxiliary power units (APUs) that can power all the electronic components of a car thus removing this heavy power demand from the engine. In 1999, BMW demonstrated at the Frankfurt Auto Show a Series-7 vehicle featuring a 5-kilowatt hydrogen IFC fuel cell that powered the onboard electrical systems and air conditioning. During the 2-week exhibition, we used the APU to run the car's lights and radio continuously without the engine running.

For buses, IFC has teamed with Thor Industries, the largest mid-size bus builder in North America and Irisbus, one of the largest European bus manufacturers, to build fuel cell powered zero emission transit buses. These prototype vehicles will take to the road this year.

#### CONSTRAINTS

The cost of fuel cells has been reduced dramatically in the past decade. The space shuttle application had a price tag of \$600,000 per kW. Commercial stationary units being installed today cost \$4,500 per kW, but fuel cells are still not competitive with existing technology which costs about \$1,500 per kW. Fuel cell production volumes are low, which increases their costs. Increased volume is needed to bring the purchase cost down and accelerate commercialization of this clean, reliable, efficient source of power so its benefits can be more widely enjoyed.

#### GOVERNMENT ACTIONS

There are a number of things the Federal Government can do to help accelerate the commercialization of fuel cell technology. These include providing financial incentives, eliminating regulatory barriers, and funding Government purchases and demonstration programs.

## FINANCIAL INCENTIVES

UTC/IFC is leading an industry effort to secure a 5-year, \$1,000 per kW tax credit for homeowners and business property owners who purchase stationary fuel cells. This initiative has gained support from major fuel cell manufacturers, suppliers and related organizations as explained in Attachment A.

In addition, these same organizations have endorsed continuation and expansion of the existing DOD/DOE buydown grant program for public sector and non-profit organization investment in fuel cell technology. An \$18 million fiscal year 2002 DOD appropriation is being sought for this initiative as indicated in Attachment B.

These efforts will make the units more affordable and increase volume. With high-production volume, costs can be reduced, thus accelerating market acceptance and deployment.

We also support tax credits and financial incentives for fuel cell vehicles.

## REGULATORY BARRIERS

We believe the Federal Government must address several regulatory barriers to fuel cell distributed generation technology. UTC recommends that the Federal Government:

- Adopt a common technical standard for interconnection of small power generation devices to the USD utility system based on the Institute for Electrical and Electronic Engineers' (IEEE) 1547 recommendation.

- Minimize the competitive impact of exit fees and stand-by charges.

- Standardize user fees for Independent Power Producers (IPPS) in the same geographic region.

- Require States to ensure that the "buy" and "sell" rates of power are the same for any given time of day or year.

## GOVERNMENT PURCHASES

The U.S. Government is the single largest energy consumer in the world. Its vast purchasing power can be put to use in the procurement and deployment of clean, efficient, reliable fuel cell systems. We suggest a 3-year Federal program to install one hundred 200 kW size units or 20 megawatts of fuel cell power at key Federal facilities.

Priority should be given to facilities in non-attainment areas as defined by the Clean Air Act of 1990 as well as those that have sophisticated and sensitive computer or electronic operations; where high-quality, reliable, assured power supply is required; where remote locations makes off-grid power generation essential; where security concerns require reliable, assured power; and at critical manufacturing facilities that support DOD or DOE missions.

In making purchasing decisions, the Federal Government uses a life cycle cost benefit analysis. Unfortunately, this calculation does not consider the environmental benefits of technologies such as fuel cells, nor does it place a cost on lost productivity due to unreliable power supplies. We recommend that the Government's economic analytical tools be revised to include these important factors in the decision-making process.

## DEMONSTRATION PROGRAMS

The Federal Government already has played a significant role as a user of fuel cell technology in NASA's space program as well as at DOD where 29 fuel cells were purchased in the early 1990s to demonstrate the performance characteristics of the technology. Since the Government will undoubtedly also be a key future customer for the technology, it is important for it to continue to support and participate in fuel cell demonstration programs.

A fuel cell bus demonstration program would be particularly beneficial. Diesel emissions from transit and shuttle buses are particularly significant since they affect large concentrations of people in urban and suburban areas, military bases and airports. Diesel school buses are of particular concern because of the potential impact on the health of vulnerable children.

Transit, shuttle and military buses return to a central location each night. Early deployment of hydrogen powered fuel cell buses offers a strategic path to establishing a hydrogen infrastructure that later can be utilized by personal vehicles and light trucks for significant environmental benefit.

While prototype fuel cell buses have been developed, a program to demonstrate this technology in real operating conditions, improve the durability and performance characteristics and create opportunities for replication across the country is needed. We support a 3-year \$40 million comprehensive program including a minimum of

\$10 million in fiscal year 2002 funding for a zero emission ambient pressure fuel cell bus demonstration program.

#### ENABLING TECHNOLOGY

Fuel cell systems such as the PC25 require a fuel-processing step to derive hydrogen from hydrocarbon feedstocks such as natural gas. If hydrogen were available directly, this step could be eliminated and a zero emission power generating system made possible. We need to continue to support the development of hydrogen production, distribution and storage infrastructure to support the deployment of zero emission stationary and mobile fuel cell applications. UTC/IFC therefore supports the reauthorization of the Hydrogen Future Act and a minimum of \$26.8 million for fiscal year 2002 funding for DOE hydrogen research, development and demonstration and an additional \$15 million for integration of fuel cells and hydrogen production systems into Federal and State facilities for stationary and transportation applications.

#### CARRIER OVERVIEW

Carrier is the world's largest manufacturer of air conditioning, heating and refrigeration systems. The company believes that with market leadership comes the responsibility for environmental leadership. Carrier led the global air conditioning and refrigeration industry in the phaseout of ozone depleting refrigerants well ahead of international and domestic mandates. And while pioneering the technologies to enable this transition to non-ozone depleting products, Carrier has also increased energy efficiency, minimized materials and product weight, introduced new air quality management features and developed the tools to evaluate a holistic building systems approach to indoor comfort cooling.

The heating, air conditioning and refrigeration industry has made significant improvements over the past two decades in technologies that benefit the environment. And while these technologies are readily available for consumers today, barriers to full deployment do exist, preventing the realization of maximum environmental benefit.

#### ENVIRONMENTAL TECHNOLOGIES FOR COMMERCIAL AIR CONDITIONING

In the commercial air conditioning market, major advancements have been achieved in large building chiller technology. Not only does Carrier manufacture non-ozone-depleting chillers throughout the world; these same products are, on average, 20 percent more efficient than their counterparts of 20 years ago, with 10–15 percent less weight for the same capacity. This has reduced raw materials like steel and the intensive energy required to produce it. In fact, we believe the industry is saving 16 million pounds of steel each year, or enough to build 7,000 cars.

Despite these breakthroughs, more than 44,000 old, inefficient, CFC-based ozone-depleting chillers remain in operation in the United States. If these chillers were replaced with today's products, roughly seven billion-kilowatt hours per year would be saved, enough to power 740,000 homes on an annual basis, saving four million tons of carbon emissions at power plants. We believe these old CFC chillers would be replaced more rapidly if it weren't for the U.S. tax code, which allows building owners to depreciate chillers over a staggering 39-year period! If this term were reduced to 15 or 20 years, the advanced chiller technologies would become more prevalent in the marketplace to the benefit of the environment.

#### ENVIRONMENTAL TECHNOLOGIES FOR RESIDENTIAL AIR CONDITIONING

Equal advancements have been made in residential systems within the last decade. Carrier introduced the Nation's first non-ozone depleting residential central air conditioning system, called Puron, in 1996—a full 14 years prior to the deadline mandated by the Clean Air Act. And while we're proud to have been the first, we congratulate the three other major manufacturers that have followed suit so far.

Carrier also leads the residential market with the highest rated efficiencies and supports a full 20 percent increase in the Federal minimum energy efficiency standard. But Carrier also believes that Federal and State governments can do more to deploy high efficiency products rapidly through tax incentives and we congratulate Senator Smith for introducing S. 207 which we view as a good framework for tax incentives, especially if the levels start at 13 SEER.

But as Federal and State governments examine tax credits, we would like to point out that opportunities exist to maximize these incentives for additional environmental benefit, like ozone protection, along with energy efficiency. Not too long ago, there was a tradeoff between efficiency and ozone protection. Most residential systems sold today operate with an ozone-depleting refrigerant scheduled for phaseout

in new products in 2010. The amount of this refrigerant required for higher efficiency systems, like 13 SEER, is 40 percent greater than standard 10 SEER systems. Fortunately, Carrier pioneered the technology that other manufacturers have followed to avoid this “Hobson’s choice” of efficiency or ozone protection. Clearly and thankfully we can have both, and we urge any tax incentive plan to maximize the environmental benefits of efficiency combined with ozone protection.

#### DEMAND MANAGEMENT TECHNOLOGY

To address electric utility demand-management initiatives, Carrier was the first in its industry to develop a web-enabled smart thermostat that will interface between a homeowner’s air conditioning system and the local utility. This technology can reduce residential peak load demand by 30 percent, frequently without the consumer’s awareness.

In essence, the thermostat allows the utility to “purchase” peak load demand from the homeowner by offering electrical rate discounts for setting-back the thermostat a few degrees. Carrier’s smart thermostats, called ComfortChoice, have already been deployed by utilities in New York, Connecticut and Washington. For every 100,000 homes installed with this technology, 150 megawatts of peak power can be saved, which is enough to power 100,000 additional homes for 1 year. At an average of \$375 per installation (labor and material) plus utility software costs and monthly communication fees, the cost of deploying these smart thermostats has been the principal barrier to more widespread use, which utilities and State policymakers are starting to address through rebates and other incentives.

#### TRAINING TO ENSURE ENVIRONMENTAL BENEFIT

Another safeguard that ensures maximum environmental benefit is the proper installation of products. Manufacturers can design and sell the most energy efficient systems, but if third party contractors do not install the system properly, the environmental benefit will be lost. Fortunately, thousands of these systems are installed properly each day by qualified technicians, but no one doubts that additional training will yield greater environmental benefit. According to the Consortium for Energy Efficiency, proper residential system installations could reduce energy consumption by as much as 35 percent. With over 300,000 installation technicians in the country, the opportunity for additional training is great.

That is why the air conditioning manufacturers and contractors have teamed up to form a national technician training and certification program called NATE—North American Technician Excellence. This program has trained a total of 10,000 technicians since its creation. The Federal Government can support NATE in two meaningful ways: (1) provide resources to raise public awareness of the program, and (2) encourage Federal facilities to ensure that they purchase service only from NATE technicians. Support of NATE will help ensure that the best environmental technologies that exist today are properly deployed so that they yield their intended benefits.

#### RESEARCH FOR FUTURE BENEFITS

Finally, the Federal Government can help develop the next generation of environmental technologies for air conditioning and refrigeration systems by continuing to fund the “Research for the Twenty-first Century” program also known as “21-CR.” This collaborative program pools the financial resources of the Federal Government, State governments and private enterprise to conduct pre-competitive research on energy efficiency, indoor environmental quality, refrigerants and others. We urge the Congress continue supporting this valuable program with a \$4 million appropriation for fiscal year 2002.

#### UTC COMMITMENT

UTC products have useful lives that can be measured in decades. That’s one of the reasons our corporate environment, health and safety policy statement requires conservation of natural resources in the design, manufacture, use and disposal of products and delivery of services. It also mandates that we make safety and environmental considerations priorities in new product development and investment decisions.

UTC products offer the potential for significant energy savings as well as improved environmental quality. Working with government and end users of our equipment we can ensure that these benefits are optimized and accelerated. We look forward to working with Congress, the Administration and other stakeholders to achieve these goals.

I would be happy to answer any questions you might have.

---

WHY SHOULD CONGRESS AND THE ADMINISTRATION SUPPORT A STATIONARY FUEL CELL TAX CREDIT?

OVERVIEW

A fuel cell is a device that uses any hydrogen-rich fuel to generate electricity and thermal energy through an electrochemical process at high efficiency and near zero emissions. Fuel cell developers, component suppliers, utilities and other parties with an interest in clean distributed generation technology are working together to enact tax credit legislation that will accelerate commercialization of a wide range of fuel cell technologies.

CREDIT DESCRIPTION

The \$1000 per kilowatt credit will be applicable for purchasers of all types and sizes of stationary fuel cell systems. It will be available for five years, January 1, 2002–December 31, 2006, at which point fuel cell manufacturers should be able to produce a product at market entry cost. The credit does not specify input fuels, applications or system sizes so a diverse group of customers can take short-term advantage of the credit to deploy a wide range of fuel cell equipment.

WHY IS A FUEL CELL TAX CREDIT NECESSARY?

A credit will allow access to fuel cells by more customers NOW when there is a grave need for reliable power in many parts of the country.

A credit will speed market introduction of fuel cell systems.

A credit will create an incentive for prospective customers, thus increasing volume and reducing manufacturing costs. As with any new technology, price per unit decreases as volume of production increases.

A credit will speed the development of a manufacturing base of component and sub-system suppliers.

BENEFITS OF SPEEDING MARKET INTRODUCTION THROUGH TAX LEGISLATION

Because fuel cell systems operate without combustion, they are one of the cleanest means of generating electricity.

While energy efficiency varies among the different fuel cell technologies, fuel cells are one of the most energy efficient means of converting fossil and renewable fuels into electricity developed to date.

Fuel cell systems can provide very reliable, uninterruptible power. For example, fuel cells in an integrated power supply system can deliver “six nines” or 99.9999 percent reliability. Thus, fuel cells are very attractive for applications that are highly sensitive to power grid transmission problems such as distortions or power interruptions.

As a distributed generation technology, fuel cells address the immediate need for secure and adequate energy supplies, while reducing grid demand and increasing grid flexibility.

Installation of fuel cell systems provides consumer choice in fuel selection and permits siting in remote locations that are “off grid.”

Fuel cell systems can be used by electric utilities to fill load pockets when and where new large-scale power plants are impractical or cannot be sited.

Fuel cell systems, as a distributed generation resource, avoid costly and environmentally problematic installation of transmission and distribution systems.

COST

The five-year budgetary impact of the credit is less than \$500 million.

KEY ELEMENTS OF A FUEL CELL TAX CREDIT FOR STATIONARY APPLICATIONS

OVERVIEW

The goal of the stationary fuel cell tax credit is to create an incentive for the purchase of fuel cells for residential and commercial use. The prompt deployment of such equipment will generate environmental benefits, provide a reliable source of power for homeowners and businesses, reduce our Nation’s dependence on foreign oil supplies, help commercialize clean technology, enhance U.S. technology leadership and create economic benefits for the Nation.

Fuel cell tax credit proposals should be designed to benefit a wide range of potential fuel cell customers and manufacturers. They should therefore be all-inclusive without discriminating between different kilowatt sized units, type of technology, application, fuel source or other criteria. Efforts should be made to keep the proposals as simple as possible to aid in effective implementation. In addition, the proposals should strike a balance between ensuring the level of tax credit provided represents a meaningful incentive that will stimulate purchase and deployment of the technology while minimizing the budgetary impact.

The following are specific elements suggested for consideration and inclusion:

#### COVERAGE

U.S. business and residential taxpayers that purchase fuel cell systems for stationary commercial and residential applications should be eligible for the credit.

#### BASIS FOR CREDIT

The credit should be based on a “per kilowatt” approach with no distinction made for the size of unit.

#### ACCESS TO CREDIT

No allocation of credit should be made to specific categories of fuel cells on an annual or total basis.

#### FUEL SOURCE

No premium or penalty should be imposed based on the fuel source.

#### DEFINITION OF STATIONARY FUEL CELL POWER PLANT

The term “fuel cell power plant” should be defined as “an integrated system comprised of a fuel cell stack assembly, and associated balance of plant components that converts a fuel into electricity using electrochemical means.”

#### CO-GENERATION

No co-generation requirement should be imposed since not all fuel cell technologies offer an effective option for co-generation.

#### EFFICIENCY

No efficiency criteria should be imposed. Fuel cell systems in the early stages of development, such as residential sized units, cannot predict the efficiency level at this time. Establishing arbitrary efficiency criteria could exclude early models for this important application, which are exactly the units that require incentives. Efficiency levels will vary based on whether proton exchange membrane, phosphoric acid, solid oxide or molten carbonate fuel cell technology is used. Designing fuel cell systems to maximize efficiency may require tradeoffs resulting in more complicated, higher cost, less fuel flexible and less durable units.

#### FLOOR/CEILING

No minimum or maximum kilowatt size criteria should be imposed.

#### AMOUNT OF CREDIT

\$1,000 per kW for all qualifying fuel cell power plants. A five-year program with a \$500 million budgetary impact is proposed.

#### DURATION

1/1/02–12/31/06.

---

### THE STATIONARY FUEL CELL INCENTIVE PROGRAM

#### BACKGROUND

The Departments of Defense (DoD) and Energy (DOE) have cooperatively supported the development and commercialization of domestic stationary fuel cell systems since 1996. In 1995 Congress appropriated funds for the DoD Office of the Assistant Secretary for Economic Security for a competitive, costshared, near-term Climate Change Fuel Cell Program (H.R. 103–747).



The Program grants funds to fuel cell power plant buyers to reduce the high initial cost of early production systems, providing up to \$1,000 per kilowatt of power plant capacity not to exceed one-third of total program costs, inclusive of capital cost, installation and pre-commercial operation. For the program's six years, the grant program significantly aided commercialization of the first generation of fuel cell systems as intended by the Congress.

#### BENEFITS OF THE PROGRAM

The fuel cell grant program has expedited market introduction of early fuel cell systems. Production quantities are low and first time costs (e.g. engineering, manufacturing facilities, tooling) are high, yielding high early unit capital costs. The grant program has facilitated an increase in manufacturing quantities thereby reducing unit cost and enabling early adopters to participate in demonstrations and field trials. Lastly, federal participation in fuel cell demonstrations and field trials has encouraged, in some cases, supplemental support from state agencies or electric utilities, further reducing costs. In virtually all cases, fuel cell projects would not be possible without the grant program support.

#### REQUESTED ACTION

Eighteen million dollars in fiscal year 2002 funding is being sought for the fuel cell grant program at \$1,000 per kW capacity. This level of funding is needed to support the growing number of fuel cell technologies and manufacturers that are bringing new fuel cell products to market. The criteria used to select applications for a program grant should be identical to that used in the last year of the program's operation.

The key criteria include, but are not limited to: demonstration by applicant of a commitment to purchase and use fuel cell power plants with a rated capacity of at least 1 kW; power plants purchased before September 2000 are not eligible; grants awarded consistent with the amount of funding available; applicants must comply with all National Environmental Policy Act and other applicable regulatory requirements; signed contract within 60 calendar days of being notified of award required; first payment to applicant (70 percent) made after applicant submits a signed factory or site acceptance test form; second payment (30 percent) dispersed after receipt of acceptable report covering a year of fuel cell operation; applicants cannot be fuel cell vendors, manufacturers or developers; priority given to projects using DoD installations; all fuel cell technologies are eligible; no restrictions on fuel type; applicant's fuel cell vendor must offer commercial warranty for one calendar year of operation; and, it is desirable to select for award a group of projects representing diverse sizes, applications, fuels and locations.

#### ANTICIPATED PROGRAM BENEFITS

Presently there are several fuel cell technologies completing advanced development and nearing commercial readiness. Over a dozen U.S. fuel cell manufacturers will field products that qualify for program grants. The fuel cell grant program has enjoyed bipartisan Congressional support for many years. Continuation of this initiative will benefit the nation by accelerating deployment of environmentally benign, reliable, distributed generation technologies to provide needed new electricity capacity.

---

#### STATEMENT OF GEORGE TAYLOR, CEO AND PRESIDENT, OCEAN POWER TECHNOLOGIES, INC.

Ocean Power Technologies, Inc. ("OPT") is an energy technology company supplying intelligent wave power electrical generation systems to utilities, independent power producers and the public sector. OPT is capitalizing on the increasing demand for low cost electricity, the need for distributed generation and the awareness of new environmentally sensitive power generation technologies. OPT is offering its customers a tested, leading edge, proprietary product which generates electricity in a reliable, non-polluting and cost-effective way.

#### OPT HAS DEVELOPED AND TESTED THE FIRST COMMERCIAL WAVE POWER GENERATION SYSTEM IN THE USA

OPT's product is a scalable wave energy conversion system which is based on the integration of patented technologies in the areas of hydrodynamics, electronics, conversion mechanics and computer control systems. It has been designed and tested

to solve the problems usually associated with harvesting wave energy: uneconomical scale, variable wave regimes and a severe environment.

OPT believes that its wave power generation system is unique in that:

- The system is a modular buoy-based product in which the modules are relatively small and hence relatively inexpensive to build and install compared to large wave energy generation systems
- Regular low cost maintenance will permit a lifetime in excess of 30 years since the system is constructed from rugged buoys, marine quality hydraulics and proven conventional moorings and anchoring and underwater transmission power cable
- The modular nature of the system allows for simple installation and easy scale-up, as well as immediate revenues streams, as the power buoys are incrementally brought on-line
- The cost of electricity produced by the system ranges between 3–4 cents/kWh for primary power and 7–10 cents/kWh for secondary power applications

OPT's system trials include multiple tests in the U.S. Navy's wave tank facility near Washington, DC, as well as operation of a unit off the coast of New Jersey for 11 months. Over that period, the ocean system produced power in varying conditions, and survived several major storms and a hurricane with waves as high as 10 meters. Based on the successful testing of the system, the Company has come to be regarded by independent experts as the world leader in buoy-based wave power generation devices.

OPT COMMANDS STRONG COST ADVANTAGES RELATIVE TO COMPETING SOURCES OF ELECTRICITY GENERATION

The cost of generating power from an OPT wave power station is projected to be 3–4 cents/kWh for 100 MW systems and 7–10 cents/kWh for 1 MW plants.

While the capital cost of OPT's system is relatively more expensive at the secondary power level, the cost is competitive at the large scale 100 MW level compared to traditional fossil fueled systems.

Comparison of Operating Cost (cents/kWh)

	Secondary Power (1 MW)	Primary Power (100 MW)
OPT System .....	7–10	3–4
Fossil Fuel .....	N/A	3–5
Wind .....	10	5–6
Diesel .....	12–100	N/A
Photovoltaic (Solar) .....	25–50	10–15

CAPITAL COST OF OPT SYSTEM

Comparison of Capital Cost  
(Dollars/kW)

	1 MW	100 MW
Coal Plant .....	N/A	1,500–3,500
Fuel Cells .....	5,000	N/A
Microturbines .....	Low	N/A
Wind/Solar .....	8,000	4,000
Other Wave Systems .....	45,000	N/A
OPT .....	*6,200	**2,300

\*20 unit cluster of 50kW units

\*\*500 unit cluster of 200kW units

Note: This data is based on OPT projections of detailed costs for 100 MW systems. Coal-based power plant costs are based on operating cost information from various utilities analysts, and Resource Data International, Inc.

THE OPT SYSTEM DELIVERS LOWER COST PER KWH OVER ITS LIFETIME

While OPT's power plant equipment is at a somewhat higher projected purchase price per kilowatt than existing conventional power plant, the total *cost per kilowatt hour* over the lifetime of the plant is much lower (see Table below). This is because the OPT Power Systems require no fuel, and maintenance operations are lower in cost (based on standard buoy maintenance procedures promulgated by the U.S. Coast Guard).

Wave Energy Compared to Wind and Solar Energy

Type	Energy Density	Predictability	Availability (percent)	Potential Sites
Wave Energy .....	High .....	Predictable in most sites .....	80-90	Virtually unlimited.
Wind Energy .....	Low .....	Unpredictable—except in limited number of sites.	20-30	Very limited.
Solar Energy (Photovoltaic) ...	Low .....	Unpredictable—except for medium number of sites.	20-30	Medium number.

Source: Independent analysts, U.S. Department of Energy, and various periodicals.

OPT HAS SUCCESSFULLY SIGNED ITS FIRST COMMERCIAL CONTRACTS

After successfully testing the complete wave power system, OPT has received its first commercial contracts for wave power generation systems from the U.S. Navy, an electric utility in Australia and the State of New Jersey.

OPT'S WAVE POWER GENERATION SYSTEMS

- High energy density for production of primary electric power
- Essentially unlimited quantities of renewable energy close to centers of population and industry. Since OPT's power generation systems use no fuel, there are no costs of transport, storage, handling or the uncertainties of fuel pricing.
- Predictable, high duty cycle power generation which can be fed into the power grid or stored
- Efficient at low and variable speed operation suited for natural energy sources.
- Highly modular system enabling lower costs, reduced construction and commissioning period, and ease of expansion or reduction of power capacities. Conventional power stations must be built on a large scale to be economical, making them vulnerable to failure and difficult to maintain. Furthermore, the modular, scaleable nature of OPT's systems enables the power capacity planned to avoid resource commitment until it is justified by actual demand.
- Also ideally suited for powering salt water desalination and hydrogen generation plants
- Non-polluting and safe energy—no toxic gases, acids or greenhouse effect and no waste disposal problem
- For conventional power plants, the "footprint" of the plant superstructure, surrounding grounds and additional facilities such as fuel unloading areas, waste settling ponds, etc. can occupy up to two square miles of expensive real estate for a 100 MW site. A comparable OPT power plant would occupy approximately the same area of effectively free ocean surface out of sight from the shore.
- Conventional power plants are based on a small number of large generators. Unscheduled maintenance and equipment down-time can significantly diminish capacity output and negatively impact costs. OPT's power generation systems are based on a large number of small generators and the effect of equipment down time or unscheduled maintenance on single units has a minimal effect on capacity output.

OPT Power Wave Station Physical Parameters

(Based on nominal 2.0 meter wave height)

Station Capacity Megawatts	Quantity OPT Units Deployed	Surface Area Acres	Min./Max. Ocean Depth Feet**	Offshore Distance Miles (Typical)
1 .....	20	5	100-300	0.5-5.0
5 .....	50	25	100-300	0.5-5.0
10 .....	100	50	100-300	0.5-5.0
50 .....	200	240	100-300	0.5-5.0
100 .....	500	480	100-300	0.5-5.0

Note: 640 acres equals 1 square mile.

\*\* Power output is reduced in ocean depths of less than 100 feet. Mooring costs increase significantly for depths greater than 300 feet.

OPT'S TECHNOLOGY

OPT is the world's leader of wave energy generation systems

- Wave energy is the most concentrated form of renewable energy  
Widespread throughout the world

Close to population centers

Predictable and dependable

Non-polluting: no exhaust gases, no noise, no visibility from shore

Scalable to high capacity power stations (100MW+)

100 square miles of ocean area off coast of California is estimated capable of producing all of California's electrical power

- Availability factor of 90 percent, with wind and solar availability factor of 30–40 percent

- OPT's system captures wave energy in a simple and cost-effective manner

Modular design makes system flexible, reliable, durable and easy to scale

Proprietary system

Innovative design allows for easy installation and maintenance

*OPT's wave energy generation system is based on a "smart", modified ocean-going buoy designed to capture and convert wave energy into a controlled mechanical force which drives the OPT electrical generator.*

- The rising and falling of the waves causes the buoy-like structure to move freely up and down. The resultant mechanical stroking is used to drive the electric generator

- The generated AC power is converted into high voltage DC and is transmitted ashore via an underwater power cable

- The OPT device is a proprietary, "smart" system as the buoy sensors continuously monitor the performance of the various subsystems and the ocean environment, so as to efficiently convert the random wave energy into useful electrical power

- In addition, the OPT system includes sophisticated techniques for automatically disconnecting the system in very large waves, and automatically reconnecting when the waves return to normal regime.

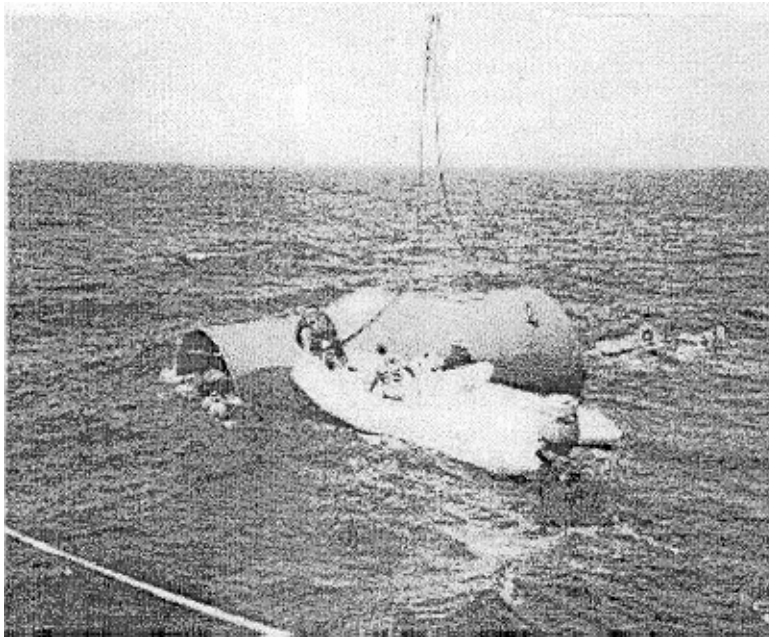

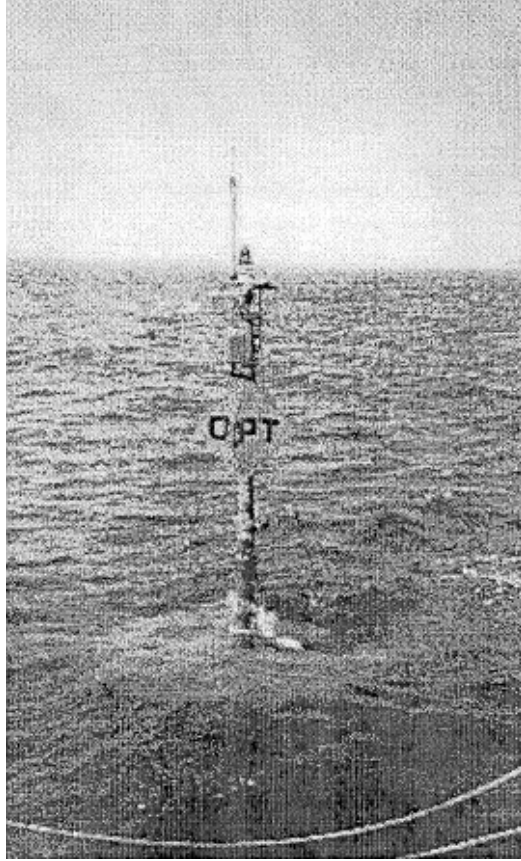

#### MODULARITY

- Power Module
  - Generator and Electronics
- OPT Power Unit
  - Buoy-like structure containing power modules, hydraulics
- OPT Power Station
  - (a) Array of power units, electrically coupled
  - (b) Increase or decrease capacity as demand requires
  - (c) Fast installation and commissioning

#### ENVIRONMENTAL ADVANTAGES OF OPT'S POWER GENERATION SYSTEMS

- No fuel—absence of CO<sub>2</sub> emissions, radiation and particulate matter pollution.
- No waste or disposal requirements, and no danger of spillage or other environmental damage.
- No noise pollution.
- No visual pollution.
- No negative impact on marine life. In fact, can encourage growth of marine life.
- Reduces shoreline erosion.

## EXPANDABILITY OF THE TECHNOLOGY

- Modular system allows for eventual expansion to power stations with capacities of 100 + MW
- 100 square miles of sea area off California coast could produce all of California electricity

## PRODUCT APPLICATIONS

- Primary Power Plants—Grid power and distributed power generation
- Secondary Power Systems—remote locations, mini-grid installations, offshore platforms
- Desalination Plants
- Water Treatment Plants
- Natural Resource Processing/Refinement Plants
- Hydrogen Production
- Autonomous Underwater Vehicles
- Remote Sensing
- Navigation Aids

## SUPPORT FROM UNITED STATES GOVERNMENT

- Office of Naval Research, U.S. Navy  
SBIR Program
- DARPA—U.S. Department of Defense  
BAA Program  
STTR Program

Support from the congressional Delegations of New Jersey and Hawaii.

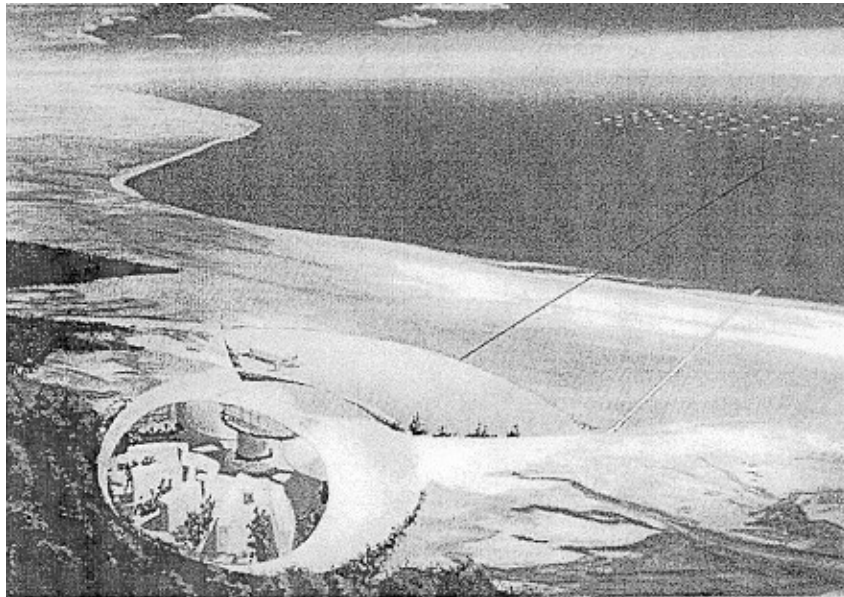

## STATEMENT OF RICHARD EIDLIN, SOLAR WORKS, INC.

Good afternoon. My name is Richard Eidlin. I am the Vice President and Business Development Director for Solar Works, Inc., a distributed generation services company that provides solar and other renewable energy systems to residential, commercial and institutional customers throughout the Northeast.

I appreciate the opportunity to offer some thoughts at today's hearing regarding the important role that solar electric photovoltaic technologies can play in address-

ing the Nation's energy needs. First, allow me to describe the types of activities that Solar Works is involved with.

Founded in 1980, Solar Works offers a wide range of standardized, grid-intertied solar electric, domestic hot water, wind turbine and energy efficiency systems. As the technology matures and market develops, we will also begin providing residential fuel cell units. Within the solar industry, Solar Works acts as a renewable energy "system integrator," in that we provide a complete set of technical, hardware, and programmatic strategies to clients. In this role, Solar Works serves as the catalyst that brings together manufacturers, energy service providers, policymakers and consumers. While maintaining its historic role as a "systems integrator", Solar Works is evolving to become a comprehensive renewable energy services firm, active in commercializing technologies and developing market-based programs for utilities, State agencies, cooperatives and housing developers interested in promoting solar electric and solar hot water systems.

Headquartered in Montpelier, Vermont, Solar Works maintains sales and service offices in eight additional Northeastern States; Connecticut, Maine, Maryland, Massachusetts, New Hampshire, New Jersey, New York and Rhode Island. Over the last 5 years, in response to the maturing domestic market for renewable technologies, Solar Works has developed its capabilities to design and deliver complete marketing and installation programs on a State or regional basis. We presently run five major market development programs for utilities, State agencies, or national manufacturers, including companies like AstroPower. As we observe the on-going discussions in Washington regarding energy policy, I would like to offer a few observations.

Over the 21 years, Solar Works has been in the renewable energy business, we have experienced several major shifts in public policy, technology development and market acceptance. Today, unlike a decade ago, there is a vibrant market for solar technologies in the United States. As we are fond of saying, "There has never been a better time to create your own electricity."

A host of factors account for this. First off, solar electric and solar hot water technology is demonstrably more reliable and resilient. Concerns dating back to the 1970s have no bearing on current discussions regarding the role for solar technologies. Solar electric photovoltaic systems have become standardized, with UL-listed, National Electric Code compliant equipment, which requires virtually no maintenance. Questions about solar domestic hot water systems' reliability have also been resolved in favor of fail-safe cost-effective equipment. Technological improvements have brought the payback for a hot water system down to 8 to 10 years, and 20 plus years for solar electric systems.

The second observation concerns the market for renewable energy. Survey after survey indicates that the American public is highly supportive of clean, domestically generated energy technologies. The past 5 years have witnessed a significant shift in the market. Once largely the domain of off-grid applications, such as water pumping, telecommunications, vacation cabins and/or rural electrification projects, PV is now becoming more widely accepted and used for grid-tied homes, businesses and schools across the country.

Homeowners and businesses are choosing solar energy systems for a number of key reasons:

(1) power quality and reliability, (2) demand for clean, non-polluting energy, (3) growing interest in generating electric power from a decentralized source, (4) escalating conventional energy costs, (5) power shortages, including brown-outs and blackouts.

PV is the ideal distributed generation technology, well suited for almost any energy application. PV systems are highly modular and flexible in nature. Recent technological advances in performance and design are creating an increasingly cost-competitive energy source. Customers such as the U.S. Postal Service understand these inherent advantages that solar generation has over back-up fossil fuel generators. While a fossil fuel generator mainly sits idle and depreciates, a solar system lowers monthly utility bills and can provide 24-hour automatic uninterruptible power supply. PV's can be easily sited, require comparatively little permitting, and produce 99.9 percent reliable power for any application. PV's also provide an excellent hedge against almost certain energy inflation.

With today's increased reliance on computers, telecommunication systems, and high performance electronic devices, any loss of power or even power quality can be very costly. Solar assisted Uninterruptible Power Supply systems (with batteries) offer a cost-effective, safe and reliable means of providing emergency backup power to homes and businesses alike.

PV's are also an excellent means of shedding load demands and avoiding summertime peak power costs, which last summer in some parts of the country soared to more than \$600 a megawatt. PV's offer utilities and businesses the option of reduc-

ing congestion on the grid and moderating the demand for additional power plants and generating capacity. For homeowners, PV's provide an assurance that the power will stay on in the event of a blackout due to a natural disaster or power scarcity.

Recent studies of the large-scale power failures during the winter of 1998-1999 in both the Northeast and Northwest strongly suggest that scaled PV installations placed at strategic places along the power grid would have prevented the blackout from cascading from State to State. Homeowners and businesses, due to net metering rules can now also "sell" power back to the utility at times when their solar electric systems are producing more power than the home or building requires. This provision, along with others is helping to drive the market for solar technologies.

It is regretful that the Federal Government during both the 1990s and today, has committed disproportionately limited resources to supporting the photovoltaics industry. In contrast, over 40 States have enacted one or more requirements to actively encourage the broader use of renewable energy sources. Net Metering, State income tax credits, renewable portfolio standards, and system benefit charges are some of the many ways renewables are being encouraged at the State level by public utility commissions and legislatures. In six States alone, (CA, IL, MA, NJ, NY, PA) over \$375 million is being collected annually from ratepayers through electric industry restructuring programs to support renewable energy development. These funds will leverage about five times their value in retail market activity, or about \$1.5 billion a year.

The upshot of all this is that the domestic solar energy market will grow ten-fold in the next 5 years, from 80 megawatts to 820 megawatts of installed capacity. According to the Energy Information Agency, photovoltaics will be the fastest growing generation technology in the United States over the next 20 years. Solar energy will still be a niche market compared to fossil fuel generated power, but it will be a multi-billion-dollar-a-year opportunity for those few companies that have the infrastructure to support its tremendous growth.

There is a historic market opportunity emerging in the United States for renewable energy technologies. An extraordinary convergence of market forces is transforming a small, niche industry into a multi-billion dollar one, almost overnight. Electric industry restructuring is literally jump-starting the market by offering customer choice and millions of dollars of financial incentives for renewable generation. Demand for zero-emission generation technology to combat global warming and air pollution is another important market driver.

The current California power crises is a good example of the inability and unwillingness of utilities to build new central station generation and transmission facilities. The answer to this lies in distributed generation systems that can be tucked into homes, neighborhoods, and businesses. Photovoltaics are the ultimate distributed technology that runs on pure sunshine. Declining costs of photovoltaic modules and renewable energy incentives enacted by all levels of government are creating an exponentially expanding market.

Given these trends, it is of concern, that the Administration's energy plan devotes limited attention toward the role of solar technologies. The substantial reductions in the Department of Energy administrative and RD&D budget for renewables is a shortsighted approach to balancing the budget. In addition, these policies are placing the domestic American solar energy industry at a competitive disadvantage to their European and Japanese counterparts. Relative to investments that other advanced industrialized nations have made in supporting PV's over the past decade, the U.S. Federal Government has directed exceptionally modest resources to building a domestic industry.

Let me return to the immediate issue of the Administration's proposed energy plan. While Solar Works supports the proposed \$2,000 income tax credit for residential energy tax credits, we are not in favor of doing this at the expense of drilling for oil in the Arctic. What is needed instead is a greater reliance on a wide range of renewable technologies, including fuel cells, hydro and wind. We also support pending legislation that would establish a national standard regarding the process by which PV systems are interconnected to the utility grid, as well as proposals to create a Federal renewable energy portfolio standard.

Here in New Hampshire as elsewhere in the Northeast, Solar Works has been working to expand the market for solar technologies. Over the past 2½ years, we have installed over 40 solar electric and solar hot water systems on homes, environmental centers and public buildings throughout the State. Our Solar on Schools Program has resulted in 19 PV systems being installed on public as well as private schools, including the 1 kW solar system located on top of the University of New Hampshire's Memorial Union Building.



Solar Works looks forward to working with the Senate Committee on Environment and Public Works in crafting policies that help to accelerate the commercialization of solar electric technologies. Thank you for your interest.

STATEMENT OF DAVID B. GOLDSTEIN, PH.D., ENERGY PROGRAM CO-DIRECTOR,  
NATURAL RESOURCES DEFENSE COUNCIL

Mr. Chairman and Members of the Committee: My name is David B. Goldstein and I am energy program Co-Director for the Natural Resources Defense Council, a national environmental organization with over 400,000 members. I wish to thank you, Mr. Chairman, and Members of the committee, for convening this hearing on energy efficiency and new technology in a national energy policy and for inviting me to speak. I also want to commend the Chairman for his leadership on S. 207, which would provide desperately needed relief to our overstressed electricity and natural gas grids.

Energy efficiency is a critical piece of any national energy strategy because of the impacts that energy use has on two things that everyone cares about: the environment and their pocketbooks. Energy use accounts for the overwhelming bulk of air pollution problems—problems that are linked to over 60,000 excess deaths per year due to direct causes such as cardiopulmonary disease. Energy production also contributes to water pollution and loss of environmental values such as wildlife protection and recreation.

Energy also costs a lot of money, as virtually all consumers and businesses have become aware over the past year. Even before the recent jumps in energy price, our Nation's energy bill exceeded half a trillion dollars a year<sup>1</sup>—or 6 percent of GDP. This is much higher than is the case in other industrialized countries, so energy is a competitive drag on the U.S. economy as well as harming household budgets and reducing the bottom line of energy-consuming businesses.

NRDC believes, and we hope members of the committee agree, that the overwhelming purpose of national energy policy should be to minimize the costs of energy services—both direct costs to consumers and costs to the environment—while providing reliably for the energy service needs of the growing economy.

Energy services are qualities like warm buildings in the winter, good lighting in buildings, access to where people want to go in a comfortable manner, and production of consumer and industrial goods. The sole purpose of energy use is to provide energy services—no one enjoys energy use for its own sake.

Energy efficiency means providing the same or better energy services for less energy consumption and cost. Optimum levels of energy efficiency maximize consumers' and businesses' well being. In theory, the market encourages everyone to optimize energy efficiency. But in practice, an overwhelming array of market failures and market barriers has prevented the economically attractive level of energy efficiency from occurring naturally: after nearly 30 years of analysis of all sectors in the economy, there is virtually no evidence of any use of energy ever having been optimized without policy intervention.

How far can we go with energy efficiency? Prior to 1973, energy use was growing in parallel with economic output (GDP). Many analysts predicted that this trend would inevitably persist in the future, and numerous forecasts of future energy needs were made based on this premise. In fact, due to energy policy activities at the State, regional, and Federal levels, and with some small boost from energy price spikes, energy use per unit of economic output began to decrease after 1973, and is now 42 percent lower than it was at the first energy crisis. About three quarters of this decline is attributable to energy efficiency improvements.<sup>2</sup>

Additional improvements in energy efficiency beyond the national average occurred in States where strong policy efforts were expended. In California, electricity intensity, which was already 28 percent below national average in 1975, had declined further to 46 percent below by 1998.<sup>3</sup> Had this not occurred, California's power crisis of the past two summers would have been far worse.

One of the best examples of how innovative policies have reduced demand for energy is in refrigerators. In the mid-1970s, the refrigerator was the largest single user of electricity in the home, and aggregate use of electricity for home refrigerators was growing at an annual rate of 9.5 percent.

<sup>1</sup>Energy Information Administration's "Energy Overview" data for 1997 show \$567 billion spent nationwide for energy, while GDP was about \$8.5 billion.

<sup>2</sup>American Council for an Energy Efficient Economy, Fact Sheet on Energy Efficiency Progress and Potential, 2001.

<sup>3</sup>Source: A.H. Rosenfeld. Testimony Before California State Committee on Environmental Quality.

If this growth rate had continued up to the present, as DOE and most utilities and their State regulators were expecting at the time, peak demand by refrigerators today would be about 150,000 MW, that's about one-fourth of today's electric capacity for the Nation.

Instead, as a result of State and Federal energy policies, including research and development, economic incentives, and six iterations of efficiency standards, the actual level of peak demand will be about 15,000 MW when the refrigerator stock turns over. The difference between actual demand and forecast exceeds the capacity of all U.S. nuclear power. Figure 1 shows the trend of growth and then decline in energy use per refrigerator after World War II.<sup>4</sup>

Figure 1

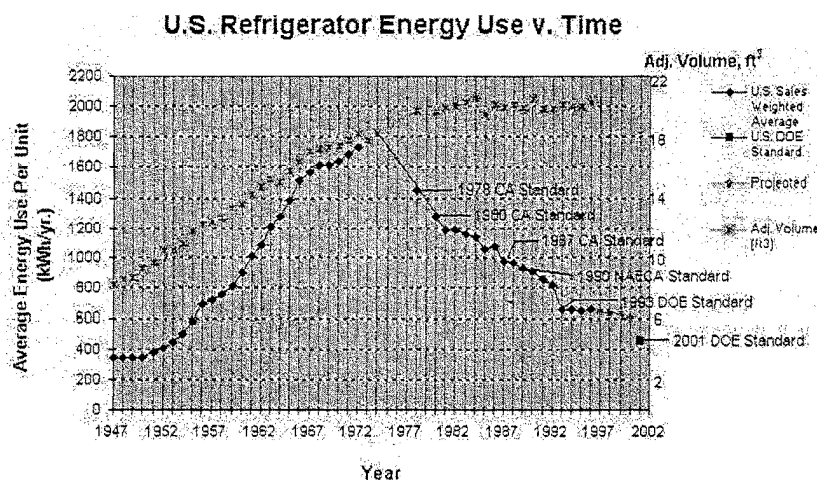

The most effective policies that have been implemented to improve energy efficiency are:

- Efficiency standards for major users of energy, such as buildings, appliances, equipment, and automobiles.
- Targeted incentives for more efficient technologies based on performance. These incentives have been administered primarily by utilities, although the State of Oregon has run a successful tax incentive program as well.
- Education and outreach on energy efficiency, although educational programs have worked best when performed in the context of financial incentive programs.

But these policies alone will not allow the Nation to reach a goal of minimizing the cost of energy services. *Standards* provide a floor for energy efficiency—they require manufacturers to use efficiency technologies that are well known and well understood and therefore can be employed by everyone. *Incentive programs* can encourage more significant improvements in energy efficiency, but they typically have been limited by the range of technologies that are already available on the marketplace.

<sup>4</sup> Exponential extrapolation of past trends was not an unrealistic assumption from either of two perspectives. First, in the mid-1970s, when the turnaround from growth to decline in energy consumption for refrigerators began, virtually every utility in the country, backed by their regulatory agencies and Department of Energy forecasters, was assuming that overall residential electricity use would continue to grow at about the same 9.5 percent rate as it had grown during the prior decades. The total growth in electricity consumption for refrigerators, considering increasing sales of the product, was also about 9.5 percent. Suggesting that this rate would come down in the future, as the author did, was highly controversial.

Second, of the 6.1 percent annual growth in energy consumption per refrigerator, one-third of the increase was due to decreases in efficiency, apparently from cost-cutting, rather than from growth in size or features as shown in Figure 1 (both of which have tended to plateau since the 1970s).

New innovative ideas that are hard for consumers to find or that have yet to be introduced by manufacturers cannot easily be acquired by incentives established on a State-by-State or regional level.

Advanced levels of energy efficiency can only be achieved by making it worthwhile for manufacturers, vendors, retailers, and consumers all to benefit from the introduction of a new technology.

That's why the incentives in your bill, Mr. Chairman, S. 207, are so critical to a comprehensive national energy policy. These types of incentives, provided through the tax system, offer a key missing piece of the solution to the problem of harnessing American ingenuity to improve energy efficiency.

S. 207 provides tax incentives for energy efficiency in buildings. Buildings are an often-overlooked source of energy waste. They consume over a third of U.S. energy use and account for about a third of total air pollution in the United States—almost twice as much as cars. Energy use in buildings can be cut in half or better using cost-effective technologies that are available to those consumers that are willing to look hard.

But in practice most of those technologies simply are not options for energy users, whether consumers or businesses, because they are too hard to find. Economic incentives can cause the entire chain of production and consumption, from the manufacturer to the contractor or vendor to the consumer, to accept new technologies rapidly. In the few cases where utility programs have been consistent enough across the country and long-lasting enough, new products have been introduced that have become or will become the most common product in the marketplace, with reductions in energy use of 30 percent–60 percent.

Examples include:

- Refrigerators, where, as discussed previously, new products that are available this year consume less than a quarter of the energy of their smaller and less feature-laden counterparts 30 years ago. The last step forward, fading 30 percent resulted from a coordinated incentive program, the Super Efficient Refrigerator Program (SERP), which was sponsored by utilities.

- Clothes washers, where some 10 percent of the market now provides cleaner clothes at reduction in energy use of 60 percent or more. This gain in efficiency resulted from a program organized by the Consortium for Energy Efficiency (CEE) and supported by Energy Star. New standards adopted by DOE—and supported by the manufacturers—will bring all of the market to this level by 2007.

- Fluorescent lighting systems, where new technologies that also will be required by manufacturer-supported Federal standards will reduce lighting energy consumption by 30 percent compared to mid-1970s practice while improving the performance of the lighting system.

The policies embodied in S. 207 are built on success stories like these.

Manufacturers have pointed out that in order to introduce new technologies that cost more and that are perceived to be risky, they need the assurance that the same product can be sold throughout the country and that the financial incentives will be available for enough time to make it worth investing in production. S. 207 does this by providing nationally uniform performance targets for buildings and equipment that will be eligible for tax incentives for 6 full years.

When the public interest community first began discussions with your staff, Senator Smith, and with committee staff, over a year ago, we felt that the approach that has been embodied into S. 207 was simply good economic and environmental policy: a Government action that could promote economic growth and protect the environment at the same time. Subsequently, we have seen how this bill could be the major part of a solution to some very real economic and environmental problems associated with energy that have emerged over the past 2 years.

Let's start with the problem of electric reliability. Not only in California and the West, but here in New Hampshire as well, we are facing the risk of electrical blackouts and/or excessively high electricity prices this summer and next. Regions that are confronting these problems are trying to move forward aggressively both on energy efficiency programs and on power plant construction. But the lead times for most actions on the supply side are far too long to provide a solution. And demand-side approaches attempted on a State-by-State level are much less effective than coordinated national activities.

Here, S. 207 could be a critical piece of a national solution. Air conditioners, for example, represent *about 30 percent of summertime peak electric loads*. Air conditioners that use a third less power can be purchased today, but they are not produced in large enough quantities to make a difference to peak load. If incentives are made available, manufacturers could begin to mass-produce these products in a matter of months, not years. Mass production and increased competition for tax incentives will drive prices sharply lower, so the incentives will be self-sustaining

in the long-term. And with 5 million air conditioners being sold every year, a sudden increase in energy efficiency could have a significant effect in balancing electricity supply and demand even after less than a year.

Another peak power efficiency measure with a very short lead time is installing energy-efficient lighting systems—either new or retrofit—in commercial buildings. Some 15 percent of electrical peak power results from lighting in commercial buildings. Efficient installations, such as those NRDC designed and installed in our own four offices, can cut peak power demand by over two-thirds while improving lighting quality. Lighting systems are designed and installed with a lead time of months, so incentives for efficient lightings as provided in S. 207 could begin to mitigate electric reliability problems as soon as next summer.

The second major new problem is the skyrocketing cost of natural gas, which caused heating bills throughout the country to increase last winter. Improved energy efficiency can cut gas use for the major uses—heating and water heating—by 30 percent–50 percent. Much of this potential could be achieved in the short term, because water heaters need replacement about every 10 years, and are the second largest user of natural gas in a typical household (and largest gas user in households living in efficient homes or in warm areas).

These types of quick-acting incentives help consumers in two different ways: first, they provide new choices that are not now available in practice for families and businesses that want to cut their own energy costs while obtaining tax relief. But they also help the non-participants, because reduced demand cuts prices for everyone.

A comprehensive energy policy aimed at minimizing the cost and environmental impacts of providing energy services for a growing economy should, we believe, be a consensus goal. While we do not yet know what the full set of measures that would be contained in a national energy plan based on least-cost are, and thus, do not yet know the full range of policy measures that would be needed to achieve such a vision, it is evident that energy efficiency will play a more important role in the next 30 years as it has in the past 30, when it was the Nation's largest source of new energy.

We also know that today's energy efficiency policies, relying primarily on efficiency regulations at the State and Federal levels and on regionally based economic incentives, are not sufficient to achieve the least-cost goal. At least one missing piece of the policy mix is the provision of long-term, nationally uniform incentives for quantum leaps forward in technology.

The Smith Bill, S. 207, fills this gap for energy uses exceeding a third of the Nation's entire energy consumption, and an even higher fraction of its energy bill.

---

STATEMENT OF TOM KELLY, PH.D., DIRECTOR, OFFICE OF SUSTAINABILITY PROGRAMS,  
UNIVERSITY OF NEW HAMPSHIRE

I would like to thank you and your staff for the opportunity to testify at today's hearing. I last had the opportunity to speak to you on the general subject of technology and the environment at a roundtable on biotechnology and agriculture here in New Hampshire last fall. Today, as then, I speak to you not as an expert on technology of any type, but as an educator charged with integrating sustainability into all aspects of the University of New Hampshire. My testimony reflects the assumption that the key link between technological potential and sustainability is education and governance, or legislation.

The role of sustainability at UNH is to collaborate with the rest of the university to ensure that all graduates develop the moral character and skills to advance sustainability in their civic and professional lives. At one level we think of sustainability as the balancing of economic viability with ecological health and human well being. But at a more fundamental level, we build our program on the premise that sustainability is about that which sustains us as human beings situated in a concrete and complex world where culture and nature are inseparable. In this view of sustainability, a strong sense of community identity and purpose grounded in a reasoned conception of "the good life" are on equal footing with clean air and water and healthy, productive soils.

I would like to offer an educator's perspective on the focus of today's hearing, innovative environmental technology, and respectfully suggest some specific legislative actions in support of innovative educational initiatives related to energy and technology. These examples envision university campuses brimming with alternatives to reckless consumption levels of non-renewable energy. Such a learning environment will advance the goal of balancing economic viability with ecological health and human well being for current and future generations through innovative educational

initiatives related to energy and technology. These examples also reflect an institutional view of society in which the public good can only be achieved if each institution does its job: government governs, education educates.

One of the fundamental jobs of education is to develop a historical consciousness or sense of history in all learners. The civic importance of this aspect of education's job is etched in stone on the face of the National Archives: "What is past is Prologue." There are at least two ways to interpret this phrase. One is practical advice that individuals and institutions will act in the future as they have in the past. As an educator, I also view it as the kind of warning and expression of hope given to us by the philosopher George Santayana: "those who ignore the past are condemned to repeat it." Santayana's guidance is full of possibilities because it proceeds from the premise that human beings have the ability to learn, which means the ability to distinguish good from evil and right from wrong in pursuit of the common good, and to act on those judgments.

Now how does this bear on today's hearing? We all recognize that this is not the first time that we as a Nation have focused our attention on the need to consume less energy and the role of technology in achieving that goal. The oil shocks of the 1970s gave rise to a remarkable effort to harmonize the resources of government, education and a genuine entrepreneurial spirit in the area of renewable energy. Indeed, many of the technologies represented at today's hearing were the focus of intense experimentation in research and development as well as small-scale applications at that time. But as writers on this period of our history have noted, "faith [in grassroots efforts to advance renewable energy] without capital was handicapped." Recognition of that political fact eventually led to the establishment of the Federal Solar Energy Research Institute (SERI). But the fact that we are here 25 years later still talking about the promise rather than the accomplishments of these technologies indicates that something went wrong. The fate of those efforts is well documented and is important to review carefully unless we want to be here in 2025 asking the same questions.

A review of the history of those efforts teaches that technological potential to advance the public good can be blocked by economic interests working through the political process; or perhaps more starkly stated, by greed corrupting governance. This is hardly a provocative statement in our current culture of cynicism about politics, but it is and should be educationally provocative and should therefore excite a sense of urgency and resolve to ensure that education is doing its job.

So where do we begin? From an educational perspective we begin with priorities and the way we frame the challenges we face and the means we employ to address them. With respect to innovative environmental technology we must shift the focus from consumers choice, efficiency, business and the economy to citizen participation, justice, governance and the polity. The economy is a subset of the polity, not the other way around. It is important to remember that the most powerful and effective force for sustaining the environmental foundation of human health and well being in the epoch of the oil shocks was not business, technology or the economy. The National Environmental Policy Act and the Clean Air and Clean Water Acts among many others resulted from engaged citizenship, not consumer choice; and this engaged citizenship was concerned with the knowledge of science and its moral application. Twenty-Five years later we have the luxury of questioning the continued effectiveness of such legislation, but only because it was successful.

We also begin at home, which for the University of New Hampshire means our Durham Campus. Some 25 years ago an event known as the battle of Durham took place amidst the energy shocks. As in the case of Federal environmental legislation, it is because of engaged citizens, not satisfied consumers, that we today enjoy the Great Bay Estuary, one of the most unique estuarine habitats in the world that provides invaluable ecological services and a serene beauty that defines our sense of place. Were it not for the efforts of those citizens, we might have had one of the world's largest oil refineries rather than a Reserve protected with the help of Federal legislation. The Office of Sustainability Programs is working with many others on this campus and in the town of Durham to bring that story to life for all current and future members of this community.

But notwithstanding that victory and the wonderful legacy of the Great Bay Estuary, there is a great deal of work left to do: as noted above, today's hearing is picking up a conversation that was interrupted by a lapse in education and governance over the last 25 years. Toward that end, the University of New Hampshire established the Office of Sustainability Programs (OSP) in 1997 to develop a university-wide education program and projects that integrate sustainability practices across all facets of the university including teaching, research and public service.

OSP collaborates with faculty, administrators, staff and students to link the emerging principles, science and institutional practices of sustainability to student

and professional development. OSP sponsored projects link curriculum and research development, campus environmental practices and partnerships with local, regional and international communities. Project areas include initiatives in climate education; biodiversity education; food and society; and, culture and sustainability.

The Climate Education Initiative, which relates most directly to today's hearing, includes projects addressing global change, transportation, energy and sustainable building design and construction standards. A sampling of current programs includes:

- A unique general education course on Global Environmental Change in collaboration with UNH's Climate Change Research Center at the Institute for the Study of Earth, Oceans, and Space. Faculty and staff from across the university as well as external stakeholders are involved in teaching students about the complexities of global change. After studying the latest trends and findings in climate and earth system science, students undertake the "search for sustainability" in which they link science and public policy through negotiating greenhouse gas reduction policies at UNH in order to meet the goals of the Kyoto Protocol;

- Developing a Transportation Demand Management Program (TDM) for the University in coordination with surrounding towns and agencies in the Seacoast region. The proposed TDM reduces air pollution and greenhouse gas emissions linked to global climate change by increasing access and mobility through public transportation and other alternative modes while reducing the number of single occupancy vehicles on campus and parking subsidies. Alternative modes include bicycle and pedestrian infrastructure such as the UNH Yellow Bike Cooperative, car and van pooling, as well as scheduling, affordable housing and telecommuting;

- A Sustainable Building, Design and Construction Standards initiative that builds on existing university resources to support research, pilot projects professional development, and university standards. In addition to direct application on campus, the knowledge generated by this project is being shared with New Hampshire schools, State offices and professional associations;

- The museum-quality "Promise of the Sun," an interactive educational exhibit in UNH's Memorial Union Building that links a demonstration solar array on the roof of the student union to a panoramic exploration of the cultural, technological and political aspects of energy choices. The exhibit involves faculty from across the university representing disciplines such as mechanical engineering, classics, art history, history, environmental policy and space science and is seen by thousands of visitors daily.

- Just last week we completed the first of its kind in the Nation greenhouse gas inventory for our campus. Through a partnership with the Portsmouth, New Hampshire-based non-profit Clean Air Cool Planet (CACP) we develop a methodology to complete an inventory of our campus emissions each year from 1990-2000. That methodology is already being shared with other campuses across the New England Region through our CACP collaboration. With the completion of the inventory, we now have the basis for setting emission targets and timelines and to develop and implement a strategic plan to meet those targets. This effort will involve all members of the UNH community under our Climate Education Initiative and will touch all parts of the university.

I began this testimony with the assumption that the key link between technological potential and sustainability is education and governance. Based upon our work at UNH, I would like to offer some specific and practical examples of initiatives on this campus that could be supported through legislation that would make a significant contribution to our educational mission and therefore to the public good in the area of energy and environment. These examples integrate innovative environmental technology into the learning environment where direct experience can be gained by students, faculty, and all members of the university community. By linking these demonstration projects to teaching, research and public service activities, innovative technologies are placed in their political context where the public good can be protected and nurtured.

1. *Demonstration Fuel Cell/Gas Turbine Co-generation Project (\$10 million).*—Support for the incremental cost of incorporating a 1 MW Fuel Cell into the university's proposed gas-turbine co-generation power plant. This demonstration project will support comparative study by undergraduate and graduate students in engineering, economics and public policy of the sustainability of Fuel Cell and Gas Turbine co-generation technologies. Studies will also include capture and reuse strategies of the water byproduct of the Fuel Cell technology. Total cost of the 1 MW Fuel Cell and 9 MW Gas Turbine co-generation plant is \$21 million.

2. *Community Alternative Energy Assessment (\$300,000).*—Support for a campus-wide alternative energy assessment that will identify high impact opportunities for employing a wide range of technologies to enhance energy efficiency. Examples in-

clude: co-generation, methane digesters, ice storage, fuel cells, and geo-thermal among others. Special consideration will be given to passive and active solar applications to address the structural disincentives that continue to retard the development of this crucial renewable energy source for sustainability. The assessment would serve as the next phase of a Climate Education Initiative greenhouse gas reduction program that has recently complete an inventory of UNH's greenhouse gas emissions each year from 1990–2000. In addition to identifying energy efficiency projects, the Community Alternative Energy Assessment will as a tool for development of a strategic plan to achieve emission reductions targets.

3. *Alternative Fuel Shuttle Vehicles (\$150,000)*.—As part of its Transportation Demand Management Program, UNH will incorporate 3 small to medium size alternative fuel transit buses carrying 14–18 passengers into its shuttle system. The shuttles will transport community members and visitors from remote parking and the surrounding community as part of its shuttle system. In addition to educating riders about energy efficiency opportunities of alternative fuel vehicles, the shuttle system will reduce campus congestion and air contamination and provide students with case studies for analyzing the energy and air quality benefits of this new technology.

4. *Phase I Vehicle Fleet Upgrade Project (\$1 million)*.—As part of its Climate Education Initiative, UNH would like to upgrade at least 50 percent of its fleet to alternatively fueled vehicles over the next 5–10 years. UNH has 248 vehicles in its fleet. Phase I target of this effort is to have 50 alternative fuel vehicles by 2005. This fleet upgrade would provide undergraduate and graduate students with case studies for analyzing the energy and air quality benefits of this new technology.

5. *Alternative Fuel Vehicles for Car Sharing Program (\$75,000)*.—As part of its Transportation Demand Management (TDM) Program UNH will develop an alternative fuel car sharing program for the campus community. The proposed program would begin with 3 vehicles and would accomplish at least three important objectives: (1) it would provide visibility as well as direct experience with alternative fuel vehicles for a wide range of faculty, staff and students; (2) the car share program would support TDM policy goals of reducing single occupancy vehicle trips to campus by ensuring the availability of emergency transportation and other unanticipated travel for faculty, staff and students that do not have cars on campus and (3) allow a wide range of faculty, staff and students to experience car sharing program's demonstrated ability to reduce individual demand for driving without a perceived loss of mobility.

6. *Sustainable School Design Institute (\$5 million/\$1 mill per year x5)*.—As part of the UNH Office of Sustainability Programs, the Sustainable School Design Institute will bring together leading professionals from the fields of architecture, engineering, occupational and public health, materials science, ecology and education to conduct research, teaching and outreach to the New Hampshire and New England communities, professional associations and businesses to ensure that our schools embody the best of sustainable design to provide healthy, productive learning environments.

7. *Methane Digester for Agricultural Energy Needs (\$1 million)*.—Demonstration project of converting dairy herd manure to methane gas as a fuel for power use that can reduce odor pollution and facilitate nutrient cycling and reduce dry matter for compost use. This technology will also facilitate research for concentrated liquid to be further broken down into dry matter for productive use as soil amendments. In conclusion, I would like to emphasize that technological potential, and particular technologies, are only part of a solution to the problems we face. Efficiency is a blind principle that tells us nothing about where we ought to be heading. For example, technology develops and interacts in an ecology: alternative fuel vehicles serving as part of a car-sharing program that reduces demand for single occupancy vehicles makes perfect sense. Alternative fuel vehicles simply replacing less efficient single occupancy vehicles will continue to drive sprawl and other land use changes and settlement patterns that undermine sustainability. Our role as educators is to ensure that the full knowledge we have and develop of our concrete and complex world is applied to the judgments and actions we take in the area of energy and the environment.

Again, I would like to express my sincere thanks to Senator Smith and the other members and staff of the Environment and Public Works Committee for the opportunity to testify.

STATEMENT OF CASS ANDARY, DIRECTOR, REGULATORY PROGRAMS, ALLIANCE OF  
AUTOMOBILE MANUFACTURERS, INC.

Good Morning, my name is Cass Andary. I am Director of Regulatory Programs at the Alliance of Automobile Manufacturers. The Alliance is a trade association of 13 automobile manufacturers representing over 90 percent of U.S. vehicle sales.

The auto industry in the United States is proud of not only its contributions to advanced technology, but also to its contributions to the U.S. economy. In a recent report,<sup>1</sup> researchers associated with the University of Michigan concluded that the automotive industry produces a higher level of output in the United States than any other single industry. Notably, U.S. motor vehicle output represented 3.7 percent of the United States gross domestic product in 1999. Many of the jobs provided by the industry are high skill jobs paying well above industry average—the average job in the automotive manufacturing sector was compensated at a level 73 percent higher than the average U.S. job.

The motor vehicle industry is one of the most technologically advanced industries in the world. Our designers use state-of-the-art computer design, our manufacturing facilities are some of the most complex and technologically advanced in existence, and our vehicles are probably the most complex and advanced consumer product sold on the market today.

The industry has reached levels of emission control and vehicle safety today never anticipated in the past using computer controlled fuel injection and advanced catalyst systems to control exhaust emissions. For safety, manufacturers have installed sophisticated air bag supplemental systems, collapsing steering wheels, seat belt pretensioners and many other advanced technologies to help save lives.

However, our quest for even better vehicles never ends. Alliance members continue to push new technology to further improve the environmental footprint of our vehicles.

First, let me point out how far we have come in controlling exhaust emissions from the traditional gasoline-fueled vehicle. For the new Federal emission standards that take effect in the 2004 model year, the industry will be meeting standards that represent a 99 percent control level for hydrocarbons and nitrogen oxides, the two main precursors to ozone or smog. Moreover, cars and light trucks will have to meet the same emission standards as part of these new regulations.

Member companies of the Alliance have invested billions of dollars in research and development. These companies are working to bring cutting-edge technologies—alternative fuels, hybrid electric, electric and fuel cell vehicles—to the marketplace.

Let me talk a bit about the new types of vehicles that the industry is busy working on today. The industry has long been active in exploring alternative fuels. Manufacturers make vehicles available that run on CNG and LPG, and others that can run on either gasoline or a mixture of fuel containing 85 percent ethanol.

A new technology that has recently appeared on the market is a hybrid-electric vehicle. Both Toyota and Honda have a vehicle selling today, and Ford, GM and DaimlerChrysler have vehicles ready to introduce in the next few years. This technology combines both a traditional engine with electric motors and a small battery pack giving the vehicle two sources of power for the vehicle. Sophisticated computer control logic shuts off the engine when possible, letting the vehicle run in electric mode, and then restarts the engine when needed.

We have also invested a lot of time and money in battery-powered electric vehicles (BEVs), mostly due to a regulatory requirement in California for these vehicles. The Alliance does not believe that battery-electric vehicles can ever become mainstream vehicles that would replace today's gasoline-fueled vehicle, but there may be market niches where some of the smaller BEVs can be sold.

The entire industry is working feverishly to develop commercially viable vehicles powered by fuel cells. You will recall that fuel cells were used in the early U.S. space program. The industry is working hard to reduce the cost of the fuel cell while improving its performance so that it can replace the traditional gasoline-fueled engine we have today. Fuel cells offer the promise of zero emissions, with a vehicle that can also meet all other customer needs and expectations. Many manufacturers are part of the California Fuel Cell Partnership, along with the California Air Resources Board and a number of Federal agencies. This partnership is working hard to develop both fuel cell vehicles and the necessary fueling infrastructure.

<sup>1</sup>Contribution of the Automotive Industry to the U.S. Economy in 1998: The Nation and Its Fifty States. Prepared for the Alliance of Automobile Manufacturers, Inc. and the Association of International Automobile Manufacturers, Inc. by the Institute of Labor and Industrial Relations, University of Michigan, the Office for the Study of Automotive Transportation, University of Michigan Transportation Research Institute, and the Center for Automotive Research, Environmental Research Institute of Michigan.



This industry is committed to continuing to push technology even further year by year, constantly improving the product, while continuing to meet the transportation needs of the public. We believe further that pursuing these goals should lead to consideration of more broadly defined programs (i.e., beyond the new vehicle transportation sector). All energy users and producers should be integrated in a comprehensive national energy strategy to achieve fuel savings with economic efficiency.

In addition, we believe that the costs of more expensive technologies are a deterrent to the market. In order to expand the use of these advanced technologies, tax credits and incentives for advanced technology vehicles [and vehicles which demonstrate significantly higher efficiencies] are necessary. Such incentives will speed acceptance and promote market forces that will make advanced technologies less cost prohibitive.

Finally, we observe that, as in all industries, both capital and human resources are finite, and are most efficiently deployed in response to market forces. Commitment schedules for capital spending, vehicle model renewals, and powertrain longevity can range from 5–10 plus years. Over the past 10 years the industry has clearly demonstrated that when resources can be shifted from continual incremental regulatory compliance pressures, the industry can and will undertake major research and development programs aimed at significant long-term energy efficiency. Clear examples are the development of hybrid electric powertrains, and the continuing investment in fuel cell systems. The commitment to market-driven advanced technology development is clearly demonstrated by these programs, which have little potential to produce sufficient sales volumes to impact CAFE within the next 5–10 years.

Thank you for the opportunity to speak today and I would be happy to answer any questions you may have.

---

STATEMENT OF ROY GAT, PH.D., ADVANCED ELECTRON BEAMS, INC.

Chairman James M. Jeffords, Senator Bob Smith, and Members of the Committee: Good afternoon esteemed Members of the U.S. Senate Committee, my name is Roy Gat. I come today to present a technology that will finally put an end to the familiar eye irritation and choking feeling we experience as clouds of poisonous gas exhausts from the bus or diesel truck just ahead of us.

INTRODUCTION

In Japan and China, powerful electron beams installed in power plants are utilized to convert tons of hazardous NO<sub>x</sub> and SO<sub>x</sub> emissions per day into useful fertilizers. Reductions of over 95 percent SO<sub>x</sub> and 80 percent NO<sub>x</sub> are achieved. Advanced Electron Beam Inc (AEB), Wilmington, MA developed a much smaller electron beam source. This source enables viable destruction of hazardous gases from smaller polluters collectively known as area polluters. Area polluters are those pollution sources that are too small or numerous to be inventoried individually. These polluters include diesel trucks, off road equipment, marine vessels, smaller boilers, heaters and turbines. These polluters together account for the vast majority of air pollution and have traditionally been the toughest challenge in the fight against air pollution. They are used in almost all industrial and consumer sectors including power generation, heating, transportation, cement, glass, steel, copper, paper manufacturing, hospitals, schools and homes. An important advantage of electron beam technology is that it simultaneously reduces NO<sub>x</sub>, SO<sub>x</sub> and VOC compounds, thereby eliminating the precursors of smog and acid rain. If adopted, the positive impact of this technology on our environment and quality of life would be dramatic and long lasting. I will briefly describe the technology, the impact of its adoption on air pollution and the possible government role in accelerating its acceptance.

THE TECHNOLOGY

In the early 1940s, microwave generators were very bulky and expensive. They were exclusively used in military radars. In the mid 1940s, Dr. Spencer of Raytheon developed a magnetron tube that made possible a much more compact microwave generator. The results of this invention are well known and spectacular. The smaller size and price tag enabled the application of microwaves in a broad array of industrial and consumer uses from cooking to semiconductor manufacturing.

Electron beams are well known to science to be an energy efficient technique to destroy NO<sub>x</sub>, SO<sub>x</sub>, and VOC's pollutants. Traditionally, generation of electron beams requires bulky and expensive equipment. This equipment is notoriously hard to maintain and operate, requiring energy guzzling pumps and technicians highly

trained in ultrahigh vacuum, and high voltage technologies. Thus far, electron beams have been limited to reducing pollution from large power plants where the high capital equipment costs of the systems can be averaged over very high throughputs.

In contrast, AEB developed an electron beam tube that is smaller, affordable and requires no pumping or maintenance in the field. Tube replacement requires about as much expertise as replacing a light bulb. In analogy to the invention of the compact microwave generator, AEB's electron beam product enables cost effective effluent reduction for area polluters.

#### ENVIRONMENTAL IMPACT

Using only 1 percent of the polluters energy output to power the electron beam results in reduction of 95 percent in SO<sub>x</sub> emissions and 80 percent in NO<sub>x</sub> emissions. Concurrent reductions in VOC's also occur and vary in amount depending on the chemical species. Values of over 90 percent have been measured for TCE.

For example, the NO<sub>x</sub> and SO<sub>x</sub> emission from a diesel truck will be mostly eliminated by an electron beam device. There will be approximately 1 percent reduction in the truck gas mileage.

Area sources comprise 65 percent of all NO<sub>x</sub> emission in the USA. Broad application of electron beam technology would result in a reduction of approximately 12,000,000 tons/yr of NO<sub>x</sub> and 2,000,000 tons/yr of SO<sub>x</sub>. According to EPA analysis, in the case of diesel fuel related pollution alone, this magnitude reduction in SO<sub>x</sub> is equivalent to removing 13,000,000 trucks off the roads saving 8,000 lives, and preventing 360,000 asthma attacks.

#### REGULATORY IMPLICATIONS

The Senate can accelerate reduction of harmful pollutants by requiring the EPA to review electron beam cost effectiveness specifically in the reduction of NO<sub>x</sub>, SO<sub>x</sub> and VOCs from area polluters. Electron beam technology has not yet been evaluated by the EPA and yet electron beams are a formidable weapon in the fight against pollution.

The costs of ownership of the electron beam technology are limited to capital costs and maintenance costs. The maintenance costs are small and could be partially offset by sales of fertilizer produced by the NO<sub>x</sub> and SO<sub>x</sub> reduction reactions. The government can propel the implementation of this technology by providing tax credits for the first year of purchase of electron beam systems. The credits will help increase initial demand for the systems so that mass production of these systems becomes viable faster. This tax credit will therefore leverage accelerated pollution control and the resulting important health and environmental benefits.

---

#### STATEMENT OF FILSON H. GLANZ, PROFESSOR EMERITUS OF ELECTRICAL ENGINEERING, UNIVERSITY OF NEW HAMPSHIRE

There is so much that we could be doing to relieve our energy problems; and we will in the future undoubtedly be much harder pressed than we are now. When a billion or so Chinese start driving automobiles, the demand for increasingly scarce oil will drive the price well beyond today's high prices. Using more oil and coal are environmentally destructive and only temporary solutions. We, as a Nation, must do all the research we can to improve energy efficiency, come up with sustainable energy sources (such as solar, wind, ocean wave, bio fuel, etc.) and innovative technologies that use these sources. It makes no sense to cut back research funds for these types of energy programs as the President's budget calls for. If we had put as much into these renewable technologies as we have put into tax breaks and subsidies for coal and oil, we would now be benefiting from their use.

There was at the hearing some discussion of short term and long-term energy needs and the different approaches needed to solve both types. This is clearly the case. But all long-term energy needs become short-term needs if inappropriate solutions are followed. I well remember, as most of you surely do also, the 1974 embargo on oil and the problems we faced then. We made some amazing progress toward energy efficiency and alternative energy in the years thereafter. Unfortunately, about 1980 a new Administration killed the programs spawned by this emergency and since the problem was past, all memory was lost. But if, for example, we had put in appropriate national building regulations at that time, our energy dependency on foreign oil would be considerably different.

Even in New Hampshire a building with some thermal mass and the correct solar orientation and fenestration would use less than half the energy of a standard equivalent building. This is well documented. And the cost is almost the same.

The large number of new homes and buildings constructed since say 1980, and the fact that most places in the United States could save well more than 50 percent on heating energy, means that we could be saving great amounts of energy with the nice consequence that heating bills would be lower, the air cleaner and our oil dependency much less. Add to this that if CAFE standards had been followed as originally intended—our total energy picture would be very rosy! It is my belief that the American people and history should hold administrations and public officials accountable for NOT planning consistently for future energy independence! But at least we have to opportunity right now to start preparing for the long term (which will be short term soon enough!). Many of the technologies discussed in the hearing do just that. But other technologies can also contribute such as passive solar heating of space, solar heating of water, day lighting of buildings, natural convective cooling, and so forth, all of which are well understood and economically beneficial besides being environmentally beneficial. But they need exposure to everyday Americans by public officials.

In summary, we cannot afford to ignore the environmental and energy problems that we have created by our lack of public resolve. We must solve them in a way that leaves our future generations a livable country/world and the resources they will need to have a healthy and satisfying life.

Thank you for the opportunity to submit this statement.

---

STATEMENT OF RONE LEWIS III, SENIOR VICE PRESIDENT, INGERSOLL-RAND (IR) AND  
PRESIDENT OF IR'S INDEPENDENT POWER SECTOR

Thank you for giving me the opportunity to submit for the Senate Environment and Public Works hearing record my testimony on the role of microturbine technology and distributed power generation in addressing America's growing energy crisis.

First, let me begin by giving you some background information on Ingersoll-Rand and its Independent Power Sector. Ingersoll-Rand is an \$8.8 billion company with more than 50,000 employees operating in over 100 countries. We serve four major global markets: climate control, industrial productivity, infrastructure and security and safety. In the area of Industrial Productivity, I am President of IR's Independent Power sector, which focuses on identifying, developing and marketing alternative-power and energy-management solutions.

As you may be aware, Chairman Smith and Members of the committee, a new type of electrical generator, called a microturbine, is rapidly becoming available to fit the electricity and heating needs of typical commercial buildings and industrial plants. About the size of a commercial refrigerator, microturbines hold great promise in supplying America's facilities with reliable and affordable power.

Microturbines are small combustion turbines that produce anywhere from 25 to 500 kilowatts of electric power. They burn a variety of fuels such as natural gas or diesel to produce the same kind of electricity provided by a utility electrical grid. Because the gas turbine engine has relatively few moving parts, it is quite reliable and can operate for long periods—typically 8,000 hours or more—with little maintenance. Microturbines produce very low emissions as they burn fuel. They are designed to easily meet stringent environmental regulations, including California's strict emission standards. Microturbines are also relatively quiet emitting low noise levels.

Our PowerWorks brand of microturbines, which has been in development for more than 10 years, is coming to market this fall. The headquarters for the engineering and manufacturing of the PowerWorks microturbine is located in Portsmouth, NH, on the former Pease Air Force Base.

These microturbines, which will provide 70 kilowatts of energy to customers, are designed to be placed in or near facilities such as hotels, supermarkets, hospitals, laundries, multi-family dwellings, schools and greenhouses, to name a few. These are locations that need a reliable, cost-effective and efficient energy source for electricity and heat.

A \$1.4 million research grant from the U.S. Department of Energy contributed to the development of the PowerWorks microturbine, which is designed to meet the same high standards found in chillers, boilers and furnaces. Our microturbines are manufactured to operate for approximately 10 years under typical operating conditions. Through their cogeneration capability, the PowerWorks microturbines can also fulfill a facility's hot water and other heating requirements.

PowerWorks connects directly to the electrical distribution system of a facility to provide high quality electricity. Our microturbines work 24 hours a day, 7 days a week for long periods with low maintenance. Designed to help satisfy electric power needs by producing electricity at the point of consumption, the PowerWorks microturbine also supports peak shaving applications. This means that microturbines can enable businesses and consumers to reduce their reliance on the power grid, especially during costly peak use hours.

IR began the field-testing phase of its microturbine development program last fall in several kinds of facilities located throughout the United States. We plan to introduce our first commercial production units in the second half of 2001.

There is no argument that this country's need for this type of energy is increasing at a steady rate. California's energy crisis underscores the need for increased energy efficiency, cleaner technologies and more reliable production. Deregulation, volatile energy pricing and tighter emission regulations have all prompted an interest in energy alternatives, such as "green" technologies like the microturbines. And there is probably no better way to get reliable and affordable energy than from your own, onsite generating equipment.

Distributed energy holds great promise in the United States for improving the generation of electricity. The report released recently by Vice President Dick Cheney's energy task force revealed that this Administration is committed to the use of renewable and alternative energy, and specifically that "microturbines could easily capture a significant share of the distributed generation market."

Furthermore, the Cheney Report was absolutely accurate in noting several challenges to the use of distributed energy. First, there is a lack of national, uniform standards governing interconnection of distributed energy to the local power grids, which is hampering the roll-out of the technology into the local marketplace. The microturbine industry needs a consistent, reliable process for grid interconnection approval that focuses on practical and cost effective safety requirements; a timely approval process that prevents foot dragging on distributed power projects; and no punitive charges from the utility for either disconnecting from the grid or using the grid as a backup. The industry is also interested in support for selling unused power back to the power grid.

Long-standing regulatory policies that support monopoly supplies also must be reversed. This will increase competition, and encourage the development and environmentally friendly alternative energy technologies. The Cheney Report correctly states, "The tools that form the necessary interface between distributed energy systems and the grid need to be less expensive, faster, more reliable and more compact."

We are pleased that the report recommends that the President direct Energy Secretary Abraham to focus R&D efforts on integrating current alternative technology programs regarding distributed energy, hydrogen and fuel cells. Fuel cell technology is of particular interest to IR because several of our industrial products currently utilize diesel engines. Fuel cell technology promises a more environmentally sound alternative and continued Federal research programs can accelerate the development of these programs.

All developers of microturbine technology would be interested in congressional and Administration support for tax credits for companies who install or use microturbine technology. Tax credits are essential to helping businesses finance their utilization of this technology, just as they have with other alternative energy sources, such as solar power. In addition, continued investment in our nation's natural gas infrastructure will help to ensure that a ready supply of natural gas is available.

We look forward to working with the Senate Environment and Public Works Committee, the rest of the Congress, and the Bush Administration to develop the necessary regulatory and legislative support that would make power from microturbine technology more readily available. We believe that once the technical, business and regulatory barriers are removed, distributed power generation will be able to fulfill its promise to America.

Thank you.

---

PUBLIC SERVICE OF NEW HAMPSHIRE,  
*June 11, 2001.*

Hon. Bob Smith,  
*U.S. Senate,*  
*Washington, DC.*

DEAR SENATOR SMITH: Representatives of Public Service of New Hampshire recently attended the U.S. Senate Environment and Public Works Committee's field

hearing which you hosted in Durham, New Hampshire on innovative environmental and energy technologies. PSNH appreciates the opportunity to attend such an informative and interesting hearing in New Hampshire. On behalf of PSNH, I would like to submit the following comments for your consideration.

As you know, PSNH owns and operates three fossil-fuel electric generation facilities in New Hampshire. During the last decade, PSNH has spent more than \$100 million on environmental initiatives and has substantially reduced emissions from its fossil-fuel generating stations. In a continuing effort to further economically reduce emissions, PSNH is paying close attention to the development of several innovative environmental technologies, among them Power Span's Electro-Catalytic Oxidation (ECO).

Power Span's ECO technology is in a research/development/test mode and, if proven to be feasible, has some promise to achieve substantial emissions reductions from coal-fired electric generation facilities. Power Span's projection is for ECO to be a very cost effective solution to the multi-pollutant question. If proven true, ECO would be a welcomed new technology in the utility industry. However, neither the first pilot project conducted at FirstEnergy's R.E. Burger plant nor the second demonstration scheduled to be completed at FirstEnergy's Eastlake plant are full scale demonstration projects. Both of these trials involve a limited quantity "slip stream" and control emissions from only a small portion of the total boiler flue gas. PSNH understands that testing of new, unproven, innovative technology typically is done in stages, however, we believe that the satisfactory full scale operation of control technology is important prior to that technology being considered "commercially available" and a feasible technology for the industry at large. PSNH remains interested in seeing a full scale testing of the ECO to demonstrate its feasibility before it is considered an industry standard.

PSNH is encouraged that new emission control technologies are being explored and is hopeful that full scale test results will match the initial results of the ECO trial as reported by Power Span. PSNH is also encouraged by the findings of EPA's 1999 Information Collection Request which indicate that reductions in mercury emissions are being achieved by existing control technologies currently in operation at coal-fired electric generating facilities. PSNH believes that additional data gathering and analysis of mercury emissions would be beneficial prior to the implementation of emissions reduction regulations. Last, we feel future regulatory programs should be flexible enough to allow utilities to utilize a combination of existing technologies, and/or innovative technologies, as well as robust market-based economic incentive programs to achieve the greatest emissions reductions. PSNH is strongly in favor of market-based trading programs in that they economically achieve real reductions.

PSNH also believes that the continued Federal funding of innovative emission control technologies and demonstration projects is crucial. This funding is especially important considering that, in many instances, forward looking environmental regulations are adopted and implementation schedules are established based on the promise of developing, unproven technologies. A critical success factor lies in commercial viability and availability of these technologies to the utility industry. PSNH urges that the compliance deadlines established under new emissions reductions requirements be at reasonable future dates such that developing technologies can be perfected and proven in full-scale commercial applications, for the benefit of all.

Thank you for conducting a field hearing in New Hampshire and providing PSNH with the opportunity to comment on this important issue. I appreciate your continued interest and efforts relative to energy and environmental issues.

Sincerely,

GARY LONG,  
*President and Chief Operating Officer.*

BRIEFING PAPERS SUBMITTED BY DR. THEODORE C. LODER III, INSTITUTE FOR THE  
STUDY OF EARTH, OCEANS, AND SPACE, UNIVERSITY OF NEW HAMPSHIRE

"OUTSIDE-THE-BOX" TECHNOLOGIES, THEIR CRITICAL ROLE CONCERNING  
ENVIRONMENTAL TRENDS, AND THE UNNECESSARY ENERGY CRISIS

BACKGROUND TO THE BRIEFING

THE ISSUES

Our present methods for solving current environmental problems are only partially working, because they attempt to solve the result of a problem and not get

to the root causes of why a particular problem has occurred. Most of our problems stem from energy issues and our tremendous dependence upon fossil fuels, especially in the transportation and power generation sectors. In addition, increasing populations worldwide and the desires of Second and Third World countries to obtain what we in the United States take for granted spells increasing worldwide environmental problems coupled with significantly increased oil/gas prices. *In summary, the risks associated with our present course are ever-increased environmental degradation coupled with a significant long lasting economic downturn, recession or depression.*

As a world community, we must realize that we will need the last remaining decades of fossil fuels to create and integrate new energy sources without losing the momentum of our developing world society. *In 10-20 years from now, we have to be at a point in our global development where we are no longer dependant on fossil fuels for our energy generation and we want to arrive there by a route that does not create global environmental and economic chaos.*

THE PURPOSE OF THIS BRIEFING WAS TO SHOW THAT:

1. We have growing environmental problems that will have major economic impacts.
2. There are technologies, presently being repressed, that are real and could replace the present fossil fuel usage with the appropriate investment in research necessary to bring them on line.
3. There are scientists ready to testify at a Senate hearing on the realities of these issues.
4. The need to move ahead is very urgent because the time necessary to implement the use of these technologies may take the better part of this decade and neither the environment nor the economics of fossil fuels can wait any longer.

The goal is not to push any specific type of technology that will "save the world", but to convince those attending that there is a whole set of new technologies that are waiting in the wings which will change the way we live on this planet for the better.

THE BRIEFING PRESENTERS AND TOPICS COVERED INCLUDED THE FOLLOWING:

Dr. Theodore Loder, Convener and overview of the issues and urgency  
 Dr. Steven Greer, Implications of the implementation of non-polluting free-energy devices  
 Mr. Thomas Valone, Present energy issues, energy devices and patent office issues  
 Dr. Paul LaViolette, Physics reassessment and anti-gravity research  
 Dr. Scott Chubb, Cold fusion, scientific responsibility  
 Dr. Eugene Mallove, Cold fusion, scientific response and patent office issues  
 Dr. Thomas Bearden, Physics reassessment, the world energy crisis, and "free energy device" technology

---

"COMPARATIVE RISK ISSUES" REGARDING PRESENT AND FUTURE ENVIRONMENTAL TRENDS.—WHY WE NEED TO BE LOOKING AHEAD NOW!

(By: Dr. Theodore Loder)

#### INTRODUCTION

Fundamentally, our present methods for solving current environmental problems are only partially working, because for the most part they attempt to solve the result of a problem and not get to the root causes of why we have a particular problem in the first place. It is somewhat akin to mopping the floor to fix a leaky roof. Most of our problems stem from energy issues and our tremendous dependence upon fossil fuels, especially in the transportation and power generation sectors. For example, the acid rain problem, unhealthy urban atmospheres, and global warming all arise from this fossil fuel dependence. The present MTBE crisis affecting our water supplies is the result of a well-intentioned attempt to reduce air pollution in gasoline engines. Each of these issues will continue to have a greater and greater economic impact on our country through increased cleanup and health costs.

*Why our present course is inadequate—An example from the automotive sector*

A simple analysis of numbers from the automotive sector tells us why we will continue to have problems (both in the United States and worldwide) and why small percentage increases in fuel efficiency will have little real effect in the long run. Increasing populations worldwide and the desires of Second and Third World countries

to have what we in the United States take for granted spells continuously increasing environmental problems. For example, by the late 1990s there were about 500 million cars worldwide with an annual production of a little less than 40 million. At the present rate of growth, there will be about 1 billion vehicles worldwide by the year 2025. Presently there is about one car per 12 people on a global basis and about 1 car per 1.3 people in the United States. Why is this a long-range problem?

As the result of increased global wealth and desire for automobiles worldwide, no matter what we do to improve efficiency, increases in carbon dioxide from this source will continue with its attendant global warming,<sup>1</sup> etc. Hybrid automobiles could help, but we must look at a second set of numbers from the United States to understand impacts. There are over 200 million automobiles in the United States and we manufacture approximately 20 million per year. Because of the “replacement lag,” it would take 10-15 years to replace existing cars, especially since some production goes toward increasing the pool. Furthermore, there is a phase-in period for any new technology, the time needed to go from development to manufacturing to sales. This will add years to the replacement cycle. Thus, even if we start today, implementation of a totally non-polluting technology useful for transportation would take the United States circa 15 years to replace our present fleet. It could occur faster in Third World countries because of the technology leapfrog phenomenon.

We have similar problems with power generation in the United States. We have dammed most easily dammable rivers and there is even a movement to remove some of the dams. Furthermore, it is presently nearly impossible to build more nuclear power plants and we are starting to shut some of them down. Changing any of this infrastructure could take one to two decades as well.

In a world where our petroleum supplies will become scarcer and more expensive within a few decades or less, we need to start our planning and acting now.

*Where we are heading and the risks of our present course*

Under our present direction we are increasing fossil fuel consumption and commensurate carbon dioxide release at an ever increasing rate. The risks associated with our present course are both environmental and economic. There will be seriously increased degradation of our environment including increased loss of plant and animal species, increased habitat loss such as rainforests and coral reefs, increased human suffering through disease and lowering of life quality, increased global warming<sup>1</sup> causing major problems through climate pattern changes and sea level rise with commensurate loss of high valued coastal real estate. The trends for all these changes can be observed today and all have varying degrees of economic impact. However, a more direct economic impact, which will be felt by everyone, is the ultimate decline of “cheap oil.”

Gregg Esterbrook, in a recent article<sup>2</sup> discusses the world’s estimated oil reserves. Based on industry estimates, he suggests that there are estimated “proven reserves” of 1,000 billion barrels of oil which only represents a 25-year supply at our present rate of consumption with its 2 percent annual increase. He states, “Whatever number is correct, the world has decades of oil ahead. What it may not have is decades of cheap oil. Once the production peak comes and reserve levels begin to dwindle, the supply/demand equation may shift quickly toward higher prices. The debate, then, centers on how soon the peak will be reached.” Estimates are that the peak will be reached by 2010. At present, the global oil trade depends on OPEC for about 42 percent of its oil consumption which could hit 50 percent by 2009. If OPEC’s reserves turn out to be inflated as some in the industry believe, then the world oil production peak may occur much sooner with a subsequent sharp hike in prices. This is just barely within our timeframe for introducing new technologies if we start now.

Finally, Esterbrook states, “. . . America has two basic choices: *Begin investing in new energy forms, staying a step ahead of OPEC and smoothing the likely transition, or wait till the next crunch hits and accept another oil-induced recession.*”

<sup>1</sup>A Rocky Mountain Institute report published on their website at <http://www.rmi.org/sitepages/pid124.asp> states:

Depending on which study you read, 1999 was either the fifth or the sixth warmest on record globally (1998 was the all-time warmest). Seven of the ten warmest years since recordkeeping began were in the 1990s, and analysis of tree rings, ice cores, and so on suggests that the decade was the warmest of the millennium. A January 2000 National Academy of Sciences study concluded that “the warming trend in global-surface temperature observations during the past 20 years is undoubtedly real and is substantially greater than the average rate of warming during the 20th century.”

<sup>2</sup>Esterbrook, Gregg. Hooray for Expensive Oil! Opportunity cost. *New Republic* (May 15, 2000), p. 21–25.

It should be obvious that an essentially permanent hike in oil prices will have a major economic impact on our country, a country where 98 percent of food is based on fossil fuels and the average food travels 1700 miles to the consumer. The slight rise in fuel costs last winter and the problems truckers had with fuel costs and homeowners had with heating oil costs are just a glimpse at the issues leading to a major economic turn down. The “gas crisis” in Europe this summer is also an indicator that these problems are not limited to the United States.

One can describe our present situation as if the environment and the world’s population were in a barrel on the river heading toward Niagara Falls. We are starting to hear the roar, but have no idea when we will get to the edge. With some major rescue efforts we can be saved, but there will be a point of no return and no one can tell us when that will be.

In summary, the risks associated with our present course are ever-increased environmental degradation coupled with a significant long lasting economic downturn, recession or depression.

As the old Chinese proverb states, “If we do not change direction, we will likely end up where we are heading.” A simple look at the numbers story tells us that we must change direction dramatically, with vision and conviction.

As a world community, we must realize that we will need the last remaining decades of fossil fuels to create and integrate new energy sources without losing the momentum of our developing world society. Because the United States is a major user of energy per capita and we affect environmental issues by both example and laws, we must lead on these issues.

*Where do we want to be in 20–30 years from now as a country and a world?*

We want to be at a point in our global development where we are no longer dependant on fossil fuels for our energy generation and we want to arrive there by a route that does not create global environmental and economic chaos.

*How do we get there from here?*

Because of the long development, manufacturing and replacement times needed to replace our present infrastructure we need to start now. A leading energy intelligence analyst, retired Army Lt. Col. Tom Bearden wrote me stating that there will be a “point of no return” by about 2003–2005, after which there will be world economic collapse 5 years later when the escalating oil prices have gone through the roof. He is suggesting that we must have replacement technologies on line on a very short time scale.

*Proposed Step One.* Hold a Senate hearing to get the ball rolling. This will show us that there is a major problem looming on the near horizon and the witnesses we have will testify to the fact that there are presently a set of technologies that can help resolve them on a relatively short time scale.

*Proposed Step Two.* Once the hearing is held then we move to an action step. As stated by Lt. Col. Bearden on this subject: In short the solution to the energy crisis is solvable, permanently, in a rather straightforward fashion. We need a fine scientific team and a set of laboratories, working on it in a Manhattan style project, and in 3 years the systems will be ready to roll of the mass assembly lines. This may need a Presidential Decision Directive and a National Emergency so the project can utilize whatever is available for quick development. He may or may not be overly optimistic at this point.

*What if we do not act now?*

Again Lt. Col. Bearden’s comments: “Make no mistake. This is the most deadly and certain strategic threat to the United States and the rest of the world, in all my experience. If we do not solve this energy problem, and deploy it very, very quickly with a massive effort, then we will overrun the 2003 “point of no return” and, just as an airplane does when it overruns the point of no return on the runway, this Nation will be heading for a total crash, as surely as the sun will rise tomorrow. Yet everywhere one looks, one sees “business as usual,” “trust us, we know best” . . .

---

NEW ENERGY SOLUTIONS AND IMPLICATIONS FOR THE NATIONAL SECURITY AND THE ENVIRONMENT: A BRIEF OVERVIEW FOR THE U.S. SENATE

(By: Dr. Steven M. Greer)

The ultimate national security issue is intimately linked to the pressing environmental crisis facing the world today: The question of whether humanity can continue as a technologically advanced civilization.



Fossil fuels and the internal combustion engine are non-sustainable both environmentally and economically—and a replacement for both already exists. The question is not whether we will transition to a new post-fossil fuel economy, but when and how. The environmental, economic, geopolitical, national security and military issues related to this matter are profound and inextricably linked to one another.

The disclosure of such new energy technologies will have far-reaching implications for every aspect of human society and the time has come to prepare for such an event. For if such technologies were announced today, it would take at least 10-20 years for their widespread application to be effected. This is approximately how much time we have before global economic chaos begins due to demand far exceeding the supply of oil and environmental decay becomes exponential and catastrophic.

We have found that the technologies to replace fossil fuel usage already exist and need to be exploited and applied immediately to avert a serious global economic, geopolitical and environmental crisis in the not-so-distant future.

In summary, these technologies fall into the following broad categories:

- Quantum vacuum/zero point field energy access systems and related advances in electromagnetic theory and applications
- Electrogravitic and magnetogravitic energy and propulsion
- Room temperature nuclear effects
- Electrochemical and related advances to internal combustion systems which achieve near zero emissions and very high efficiency

A number of practical applications using such technologies have been developed over the past several decades, but such breakthroughs have been either ignored due to their unconventional nature—or have been classified and suppressed due to national security, military interests and “special” interests.

Let us be clear: the question is not whether such systems exist and can be viable replacements for fossil fuels. The question is whether we have the courage to allow such a transformation in world society to occur.

Such technologies—especially those which bypass the need to use an external fuel source such as oil or coal—would have obvious and beneficial effects for humanity. Since these technologies do not require an expensive source of fuel but instead use existing quantum space energy, a revolution in the world’s economic and social order would result. These implications include:

- The removal of all sources of air pollution related to energy generation, including electric power plants, cars, trucks, aircraft and manufacturing;
- The ability to “scrub” to near zero effluent all manufacturing processes since the energy per se required for same would have no cost related to fuel consumption. This would allow the full application of technologies which remove effluent from smokestacks, solid waste and waterways since current applications are generally restricted by their energy costs and the fact that such energy consumption—being fossil fuel based—soon reaches the point of diminishing returns environmentally.
- The practical achievement of an environmentally near-zero impact yet high tech civilization on earth, thus assuring the long-term sustainability of human civilization.
- Trillions of dollars now spent on electric power generation, gas, oil, coal and nuclear power would be freed to be spent on more productive and environmentally neutral endeavors by both individuals and society as a whole.

Underdeveloped regions of the earth would be lifted out of poverty and into a high technology world in about a generation—but without the associated infrastructure costs and environmental impact related to traditional energy generation and propulsion. Since these new systems generate energy from the ambient quantum energy state, trillion dollar infrastructure investments in centralized power generation and distribution would be eliminated. Remote villages and towns would have the ability to generate energy for manufacturing, electrification, water purification, etc. without purchasing fuels or building massive transmission lines and central power grids.

Near total recycling of resources and materials would be possible since the energy costs for doing so—now the main obstacle—would be brought down to a trivial level.

- The vast disparity between rich and poor nations would quickly disappear—and with it much of the zero-sum-game mentality which is at the root of so much social, political and international unrest. In a world of abundant and inexpensive energy, many of the pressures, which have led to a cycle of poverty, exploitation, resentment and violence would be removed from the social dynamic. While ideological, cultural and religious differences would persist, the raw economic disparity and struggle would be removed from the equation fairly quickly.

Surface roads—and therefore most road building—will be unnecessary as electrogravitic/antigravity energy and propulsion systems replace current surface transportation systems.

- The world economy would expand dramatically and those advanced economies such as in the United States and Europe would benefit tremendously as global trade, development and high technology energy and propulsion devices are demanded around the world. Such a global energy revolution would create an expanding world economy which would make the current computer and Internet economy look like a rounding error. This really would be the tide which would lift all ships.

- Long term, society would evolve to a psychology of abundance, which would rebound to the benefit of humanity as a whole, a peaceful civilization and a society focused increasingly on creative pursuits rather than destructive and violent endeavors.

Lest all of this sound like a pipe-dream, keep in mind that such technological advances are not only possible, but they already exist. What is lacking is the collective will, creativity and courage to see that they are applied wisely. And therein lies the problem.

As an emergency and trauma doctor, I know that everything can be used for good or for ill. A knife can butter your bread—or cut your throat. Every technology can have beneficial as well as harmful applications.

The latter partially explains the serious national security and military concerns with such technologies. For many decades, these advances in energy and propulsion technologies have been acquired, suppressed and classified by certain interests who have viewed them as a threat to our security from both an economic and military perspective. In the short term, these concerns have been well-founded: Why rock the global economic boat by allowing technologies out which would, effectively, terminate the multi-trillion dollar oil, gas, coal, internal combustion engine and related transportation sectors of the economy?

And which could also unleash such technologies on an unstable and dangerous world where the weapons applications for such technological breakthroughs would be a certainty? In the light of this, the status quo looks good.

But only for the short term. In fact, such national security and military policies—fed by huge special interests in obvious industries and nations—have exacerbated global geopolitical tensions by impoverishing much of the world, worsening the zero-sum-game mind set of the rich vs. poor nations and brought us to a world energy emergency and a pending environmental crisis. And now we have very little time to fix the situation. Such thinking must be relegated to the past.

For what can be a greater threat to the national security than the specter of a collapse of our entire civilization from a lack of energy and global chaos as every Nation fights for its share of a limited resource? Due to the long lead time needed to transform the current industrial infrastructure away from fossil fuels, we are facing a national security emergency which almost nobody is talking about. This is dangerous.

It has also created a serious constitutional crisis in the United States and other countries where non-representative entities and super-secret projects within compartmented military and corporate areas have begun to set national and international policy on this and related matters—all outside the arena of public debate, and mostly without informed consent from Congress or the President.

Indeed this crisis is undermining democracy in the United States and elsewhere. I have had the unenviable task of personally briefing senior political, military, and intelligence officials in the United States and Europe on this and related matters. These officials have been denied access to information compartmented within certain projects, which are, frankly, unacknowledged areas (so-called “black” projects). Such officials include members of the House and Senate, President Clinton’s first Director of Central Intelligence, the head of the CIA, senior Joint Staff officials and others. Usually, the officials have little to no information on such projects and technologies—and are told either nothing or that they do not have a “need to know” if they specifically inquire.

This presents then another problem: these technologies will not be suppressed forever. For example, our group is planning a near term disclosure of such technologies and we will not be silenced. At the time of such a disclosure, will the U.S. Government be prepared? It would behoove the U.S. Government and others to be informed and have a plan for transitioning our society from fossil fuels to these new energy and propulsion systems.

Indeed, the great danger is ignorance by our leaders of these scientific breakthroughs—and ignorance of how to manage their disclosure. The advanced countries of the world must be prepared to put systems in place to assure the exclusive peaceful use of such energy and propulsion advances. Economic and industrial interests should be prepared so that those aspects of our economy which will be adversely affected (commodities, oil, gas, coal, public utilities, engine manufacturing, etc) can

be cushioned from sudden reversals and be economically “hedged” by investing in and supporting the new energy infrastructure.

A creative view of the future—not fear and suppression of such technologies—is required. And it is needed immediately. If we wait 10-20 more years, it will be too late to make the needed changes before world oil shortages, exorbitant costs and geopolitical competition for resources causes a melt-down in the world’s economy and political structures.

All systems tend toward homeostasis. The status quo is comfortable and secure. Change is frightening. But in this case, the most dangerous course for the national security is inaction. We must be prepared for the coming convulsions related to energy shortages, spiraling costs and economic disruption. The best preparation would be a replacement for oil and related fossil fuels. And we have it. But disclosing these new energy systems carries its own set of benefits, risks and challenges. The U.S. Government and the Congress must be prepared to wisely manage this great challenge.

Recommendations for Congress:

- Thoroughly investigate these new technologies both from current civilian sources as well as compartmented projects within military, intelligence and corporate contracting areas;
- Authorize the declassification and release of information held within compartmented projects related to this subject;
- Specifically prohibit the seizing or suppression of such technologies
- Authorize substantial funding for basic research and development by civilian scientists and technologists into these areas;
- Develop plans for dealing with disclosing such technologies and for the transition to a non-fossil fuel economy. These plans should include: military and national security planning; strategic economic planning and preparation; private sector support and cooperation; geopolitical planning, especially as it pertains to OPEC countries and regions whose economies are very dependent on oil exports and the price of oil; international cooperation and security; among others.

I personally stand ready to assist the Congress in any way possible to facilitate our use of these new energy sources. Having dealt with this and related sensitive matters for over 10 years, I can recommend a number of individuals who can be subpoenaed to provide testimony on such technologies, as well as people who have information on unacknowledged special access projects within covert government operations which are already dealing with these issues.

If we face these challenges with courage and with wisdom together, we can secure for our children a new and sustainable world, free of poverty and environmental destruction. We will be up to this challenge, because we must be.

#### THE RIGHT TIME TO DEVELOP FUTURE ENERGY TECHNOLOGIES

(By: Thomas Valone, M.A., P.E.)

##### INTRODUCTION TO COMPELLING EVIDENCE ABOUT THE COMING CLIMATE CHANGE

In 1900, Nikola Tesla, the father of AC electricity, warned against using fuel for energy.<sup>1</sup> Current man-made Greenhouse Forcing of the atmosphere has been measured to be 2.4-4.3 W/m<sup>2</sup> by the Global Warming International Center (GWIC). “A change of 7.5 to 10 W/m<sup>2</sup> will *completely alter seasonal characteristics*, e.g. from winter to spring. Thus, 2.4-4.3 W/m<sup>2</sup> of Greenhouse Forcing is quite a significant alteration of energy balance.” This is a measure of the watts (energy) per meter squared (area) that is being radiated into the atmosphere from our excessive carbon-based emissions. Note carefully that in 1997, the Institute for Policy Studies released a report that declared the World Bank was solely responsible for DOUBLING the world’s output of carbon by its overseas fossil fuel investments through the life of the investment.<sup>2</sup> This simple comparison of two different studies suggests that the DOUBLING of our Greenhouse Forcing into a range of 4.8-8.6 W/m<sup>2</sup> may be anticipated in the next couple of decades.

The GWIC 1999 News Flash went on to further conclude:

“The man-made alteration of energy balance in the General Circulation system determines how chaotic our atmospheric and oceanic systems will be . . . simple thermodynamics predicts an OSCILLATORY NATURE of the change in

<sup>1</sup> Tesla, Nikola, “The Problem of Increasing Human Energy,” Century, June, 1900.

<sup>2</sup> “The World Bank and the G-7: Changing the Earth’s Climate for Business,” Ver. 1.1, Aug. 1997, IPS.

climate in any one ecological zone due to global warming. Global warming causes 'extreme events' and bad weather in the near term. In the long term it may cause the earth to transition to another equilibrium state through many 'oscillations in climatic patterns.' The magnitude of these oscillations could easily 'exceed' the difference between the end points."

From chaos theory, the end points are where we start and where we end up. In other words, as the earth climate seeks a new equilibrium point, with the forcing function of increased energy input, it may get much hotter AND much colder with a vengeance as the climate goes haywire for an undetermined amount of time.

Make no mistake about it, the earth has now surpassed 300 ppb (parts per billion) of CO<sub>2</sub> (a potent greenhouse gas) for the first time in 400,000 years, according to ice core analysis by Tom Wigley from the National Center for Atmospheric Research. He also stated on a recent NOVA program that we need to cut fossil fuel use by 50 percent or more to stabilize CO<sub>2</sub> because of increased energy demand that is predicted to be 60 percent more by 2020. Worse than that is the projected level of CO<sub>2</sub> by 2050: *an astounding 600 ppb!* At the same time, *Oxygen Inventory Depletion* (OID) is occurring: worldwide levels of oxygen have decreased by 50–70 ppm since 1958 when the measurements were first taken.<sup>3</sup>

Need we mention that right now the Arctic ice is melting at a rapid rate? In 1999, scientists reported that 46 years of data documenting the declining extent of the Arctic Sea ice yield a 98 percent probability that it is due to man-made causes.<sup>4</sup> The average annual temperatures in Alaska and Siberia have climbed as much as seven (7) degrees F in the past two decades reducing sea ice thickness by about 40 percent of what it was in 1980.<sup>5</sup> Why is the loss of this natural heat sink important? The Arctic sea ice covers an area the size of the United States. Without this natural reflector of solar energy, the same area of exposed ocean water will absorb as much as 100 times more solar energy than ice. This new energy influx will, of course, simply ADD to the already accelerating global warming due to greenhouse gases.

To summarize, "experts believe human activities could be ending the period of relative climatic stability that has endured over the last 10,000 years, and that permitted the rise of agricultural and industrial society."<sup>6</sup>

#### IS GLOBAL WARMING HARMFUL TO HEALTH?

In a word: YES!

"Computer models have predicted that global warming would produce several changes in the highlands: summit glaciers (like North Pole sea ice) would begin to melt, and plants, mosquitoes and mosquito-borne diseases would migrate upward into regions formerly too cold for them. All these predictions are coming true."<sup>7</sup>

Dr. Epstein, Associate Director at the Center for Health and the Global Environment at Harvard Medical School, further reports that the West Nile virus, spread by mosquitoes, broke out for the first time in N. America just last year. Washington residents know that it has already spread to Maryland in October, 2000. "Malaria and dengue fever are another two of the mosquito-borne diseases most likely to spread dramatically as global temperatures head upward." Regarding these diseases, it is important to note that NO VACCINE is available and the causative parasites are becoming resistant to standard drugs. El Ninos are expected to become more common and severe—which means that the diseases they produce could become more prevalent as well (such as waterborne diseases like cholera). He concludes that, "Cleaner energy sources must be put to use QUICKLY AND BROADLY, both in the energy-guzzling industrial world and in developing nations, which cannot be expected to cut back on their energy use . . . The world's leaders, if they are wise, will make it their business to find a way to pay for these solutions."

#### HOW MUCH WILL IT TAKE TO CORRECT THE CLIMATE PROBLEM?

"The Intergovernmental Panel on Climate Change, established by the United Nations, calculates that halting the ongoing rise in atmospheric concentrations of greenhouse gases will require a whopping 60 percent to 70 percent reduction in

<sup>3</sup> Keeling et al., "Seasonal and interannual variation in atmospheric oxygen and implication for the global carbon cycle", *Nature*, Vol. 358, 8/27/92, p. 354

<sup>4</sup> Vinnikov, *Science*, Dec. 3, 1999, p. 1934

<sup>5</sup> Linden, Eugene, "The Big Meltdown," *TIME*, Sept. 4, 2000, p. 53

<sup>6</sup> Brown, Lester, et al., *State of the World*, Worldwatch Institute, 1999, p. 25, citing U.N. 1997 report

<sup>7</sup> Epstein, Paul, "Is Global Warming Harmful to Health?" *Scientific American*, August 2000, p. 50

emissions.”<sup>8</sup> They are not the only agency arriving at that conclusion. The Worldwatch Institute concurs, stating that “stabilizing atmospheric CO<sub>2</sub> at safe levels will require a 60–80 percent cut in carbon emissions from current levels.”<sup>9</sup>

#### CAN OIL PRODUCTION KEEP UP IF WE IGNORE THE CLIMATE CHANGE?

In a word: NO! If we just continue as we do today with the selfish, business-as-usual attitude and clamor for more oil, do we stand a chance of enjoying a reasonable lifestyle for the next 20 years? Seeing that approximately 80 percent of the oil produced today comes from fields discovered before 1973, most of which are in decline, we must hesitate before coming to an optimistic conclusion. If we realize that the TOTAL world production of oil has increased less than 10 percent in the past two decades, then we might start to get concerned.<sup>10</sup> If we think about the fact that the U.S. energy demand grows at a rate of 1.1 percent per year, from 95 to 121 quadrillion Btus (quads) by 2020, we must ask where will the EXTRA 27 percent come from? Transportation is rated by the U.S. Department of Energy to be the most rapidly growing sector. However, as domestic crude oil production is projected to DECLINE from 6.3 to 5.3 million barrels per day by 2020, we gas-guzzling Americans naively believe that we can demand FROM SOMEWHERE a 30 percent increase from 2.90 million barrels of oil per day to 3.81 million barrels of oil per day by 2020!<sup>11</sup>

Instead, the OPEC nations, where 50 percent of our imported oil comes from, have a different story in mind for us. World production of oil is expected to peak by 2010 and then begin to decline, which will forcibly reduce production.<sup>12</sup> Knowing this fact, give or take a few years, the OPEC nations decided instead to *decrease* their output of oil NOW by only 1.2 percent in 1999 which drove prices up dramatically, causing a lot of oil-addicted nations to complain bitterly in protest. The protests had no effect on the producers. “OPEC Blames Taxes for High Oil Prices” read the headlines in the *Washington Post* (9–29–00, p. A22) which went on to say:

“Saudi Arabia is the only OPEC Nation with the capability to boost oil production significantly, a move that would harm the finances of other member nations . . .”

*The conclusion is obvious:* It is nearly impossible, even with the “hard-line approach” advocated by G.W. Bush, to continually increase our imports of and addiction to oil even over the next 10 years while OPEC is already beginning THE SQUEEZE. In September 2000, the first OPEC summit in 25 years was held. As the United States and European Union called on OPEC to increase production, OPEC simply agreed to “provide adequate, timely and secure supplies of oil to consumers at fair and stable prices.” Of course that’s what any dominant dealer with 2/3 of the market will do! With Iraq selling the United States more oil than Kuwait is today, do we go to war over oil again?

#### SOLVING THE OIL CONSUMPTION AND GLOBAL WARMING PROBLEM SIMULTANEOUSLY

The clear answer to both dilemmas portrayed above is to begin a forced weaning process aimed at creating a *government-mandated 1 percent reduction (based on Y2K usage) per year in oil consumption and/or oil imports every year for the next 20 years, with the second decade adding 1 percent to each year’s reduction.* Phase I amounts to a mandatory reduction, on the average, of 200,000 barrels of oil per year, for the next 10 years, yielding a 10 percent total reduction by 2010. Phase II, in 2010, would increase the reduction by 1 percent each subsequent year (2 percent, 3 percent, 4 percent, etc.) yielding a 55 percent + 10 percent = 65 percent total reduction by 2020. At first, a gradual reduction in oil imports by a fraction of 1 percent could be mandated with that fraction made up by domestic hybrid cars sales that have a tax incentive. The last few years of the decade program would have reductions greater than 1 percent mandated. This should be called the “The U.S. Energy Independence Initiative” or something like that. As a vital part of this process, a 10-year U.S. Energy Manhattan Project with emergency funds allocated to emerging energy developments (many of which are already invented) is required for successful replacement of current technology with carbon-free, fuel-less energy tech-

<sup>8</sup> *ibid.*, p. 57

<sup>9</sup> Brown, p. 26

<sup>10</sup> *ibid.*, p. 25

<sup>11</sup> Annual Energy Outlook, DOE Energy Information Administration. EIA-X035

<sup>12</sup> Brown, p. 25

nologies.<sup>13</sup> A public education process needs to begin immediately as well to prepare all industrial, transportation, and housing sectors for the transition.

The reason for an average of 1 percent reduction in oil usage per year is that within 10 years, a total of 10 percent (based on Y2K usage) reduction will be achieved. By then, fuel-less, carbon-free energy generators will be commercially available. That starts Phase II where an increasing amount of oil will be taken away from the market each year, before the OPEC nations force the issue.

#### END THE PRESENT SUPPRESSION OF EMERGING ENERGY TECHNOLOGIES

From my experience, the present management of the U.S. Energy Department, State Department, and Commerce Department has engaged in an outright and successful attempt to prevent viable emerging energy technologies from reaching the market and the public. They have rescinded legitimate grants that had already been awarded, prevented allowed patents from being issued, blocked approved conferences from taking place, and distorted accurate news before it is reported. Furthermore, certain non-profit organizations, most notably the American Physical Society, have abused their non-profit status by heavily lobbying government agencies and the media to encourage such suppression.

For example, the Public Affairs Coordinator for the American Physical Society, Dr. Robert Park, has further used his position of power to unduly influence the government and the media to target certain individuals and inventions, even to the extent of defaming their character, mine included, and depriving of their livelihood to suit his unscrupulous desires for scientific dominance. The Patent Office, State Department, and the Commerce Department, have been found on numerous occasions to obey his suggestions/demands on a particular issue. Examples and a chronology of such abuses have been cataloged. Both the U.S. Department of Energy (DOE) and the U.S. Patent Office have, for example, made public statements that clearly discriminate against cold fusion, a viable new physics discovery celebrating its tenth anniversary last year. Their practices of rescinding nuclear energy research grants or recalling a patent that already has been issued a patent number and posted in the Official Gazette, shows to what extent they will go to prevent anything resembling cold fusion from gaining recognition. One explanation seems to be stemming from the \$249 million that the hot fusion research program (Tokamak and laser confinement) are already receiving in fiscal year 2000. However, these ongoing programs still do not have viable overunity output results even after decades of Federal DOE expenditures and will not for at least another two decades, according to the U.S. DOE! The suppression practices referred to above must stop in order to allow emerging energy technologies to reach the market.

#### CONCLUSION

In the short term, the development of a retrofit carburetor device for all cars, that reclaims or transmutes the carbon from the exhaust, can drastically reduce the emissions of CO<sub>2</sub> from transportation vehicles. (The transportation sector presently contributes to 33 percent of the carbon emissions.)<sup>14</sup> Preliminary results from this type of device shows a dramatic improvement in mileage as well, making it attractive for consumers.<sup>15</sup>

As the new fuel-less, carbon-free energy sources are brought to market, the reduction in oil demands will become easier and more acceptable. If the U.S. Government establishes a time-table to meet the 65 percent reduction in CO<sub>2</sub> emissions by 2020, ostensibly targeting the importation of oil, the earth can reverse its beginning of climatic oscillations with the present Greenhouse Forcing. I pray that our lawmakers will have the wisdom to adopt some of the above-mentioned measures to ensure our future.

<sup>13</sup>Valone, Thomas, "Future Energy Technologies," *Proceedings of the Annual Conference of the World Future Society*, 2000.

<sup>14</sup>U.S. DOE Energy Information Administration, Energy INFOcard, 1999

<sup>15</sup>Future Energy: Proceedings of the First International Conference on Future Energy, Integrity Research Institute, 1999, CD-ROM

## FUTURE ENERGY TECHNOLOGIES

(By: Thomas Valone M.A., P.E.)

## ABSTRACT

Today 85 percent of our country's energy comes from the combustion of dead fossils, a dirty fuel that is forcing the world's atmosphere to overheat. However, new 21st century energy sources that produce no carbon emissions and do not contribute to global warming are now emerging. Beyond the realm of fuel cells and hydrogen is the non-conventional world of "future energy." Some of the best examples are new and exciting generators that release trapped potential energy from nature in ways never dreamed of before. Others innovatively apply clean fuels in conventional systems that are surprisingly simple and yet very efficient. Still others qualify as promising theoretical technologies that are a focus of attention for NASA and the USDOE. Most of them have one thing in common: they are very scientific but are relatively unknown to the general public. This presentation summarizes the latest breakthroughs in future energy. With scientific explanations of the input energy and output energy, the overunity efficiencies can be understood by average audience members. Included in the quantitative article are the inventions of Brown, Graneau, Jefimenko, Miley, Shoulders, Wallman, and others. The energy revolution is now beginning. It is time to understand the clean alternatives to dead, poisonous fuel.

*Keywords:* future energy, overunity, betavoltaic, biomass, COFE

## INTRODUCTION

In 1998, the U.S. Department of Energy (DOE) issued its *Comprehensive National Energy Strategy* (CNES)<sup>1</sup> that included as one of its five goals, the following aspiration:

*Goal IV: Expand future energy choices*—pursuing continued progress in science and technology to provide future generations with a robust portfolio of clean and reasonably priced energy sources.

*Objective 1.*—Maintain a strong national knowledge base as the foundation for informed energy decisions, new energy systems, and enabling technologies of the future.

*Objective 2.*—Expand long-term energy options.

However, the DOE has not engaged in developing, much less maintaining a robust knowledge base of future energy choices, nor expanded research into new energy systems or long-term energy options, mainly due to upper management decisions. In a study performed by Integrity Research Institute on the progress of the CNES 2 years later, it is surprising that instead the DOE has worked to actively suppress enabling technologies of the future. Furthermore, concern for global warming and the expected increase in carbon emissions by the American society clearly do not enter the present DOE policies. The DOE instead recently: (1) endorsed natural gas use for future generations, (2) rescinded a Nuclear Energy Research Initiative (NERI) grant awarded to a prominent professor for transmuting radioactive waste, and (3) reversed an initial offer to host a Conference on Future Energy (COFE). Therefore, it is clear by these and many other DOE practices that it is up to the private sector to conduct scientific research into new energy systems and enabling technologies of the future in order to replace carbon-emitting fuel systems.

As a guideline, it is generally agreed that emerging energy technologies that qualify as true future energy must not produce carbon emissions nor contribute to global warming if we are to have a future planet earth. The reason for this is as Worldwatch Institute notes: "Stabilizing atmospheric CO<sub>2</sub> concentrations at safe levels will require a 60–80 percent cut in carbon emissions from current levels, according to the best estimates of scientists."<sup>2</sup>

## FUTURE ENERGY OVERUNITY

To understand emerging energy principles, it is helpful to examine the operation of a heat pump, which converts environmental free energy into useful work. The standard heat pump is a good example of an "overunity" system (energy out > energy in) releasing potential energy from the environment where the heat energy output is always in the range of 2 up to 7 times the input electrical energy. This so-called "coefficient of performance" represents an overunity efficiency, that does not violate any physics laws, if one considers, *as the consumer does*, how much energy

<sup>1</sup>Comprehensive National Energy Strategy, U.S. Dept. of Energy, April 1998, DOE/S-0124, (National Energy Policy Plan) available at <http://www.hr.doe.gov/nesp/cnes.html>

<sup>2</sup>State of the World 1999, Brown, Flavin, and French, W.W. Norton & Co., New York

must he put in to get the predicted energy output. Thus, the concept of “overunity,” as also the concept of “free energy” has evolved from the consumer’s point of view. What does it cost him to receive his heat, air conditioning, cleaning, or propulsion outputs? The closer it gets to “free,” the more desirable it is for the consumer and, we might add, to Third World countries who cannot afford to build the thousands of miles of high voltage wires (infrastructure) to support a centralized energy system. Locally installed, modular heat and electricity generators will replace present utility-based service in the future. Then, large area blackouts will be a thing of the past. Energy will be for the most part, a one-time investment, included in the house, car, or spaceplane of one’s choice. However, much needs to be done for these systems to supplant the established energy businesses that are the nation’s major polluters. A commitment to a carbon-free energy economy, with financial backing, is required for such large changes to take place.

#### COLD FOG DISCOVERY

Many other systems exist today, in a research, development, or theoretical stage, which also convert potential energy into useful work. The first example is the “Cold Fog” invention of Dr. Peter Graneau from Northeastern University that converts chemical bond energy into kinetic energy. Intermolecular bond energy in water is an available amount of energy estimated at 2.3 kJ/g. When injected with a high voltage capacitor discharge of 39.8 Joules, normal rainwater is accelerated into a cold fog that loses about 31.2 Joules of low-grade heat and a comparable amount (29.2 Joules) in fog kinetic energy output. As reported in the *Journal of Plasma Physics*,<sup>3</sup> the output energy thus exceeds the input energy by about 100 percent creating a 2-to-1 overunity condition favorable for reduction to a motorized conversion system.

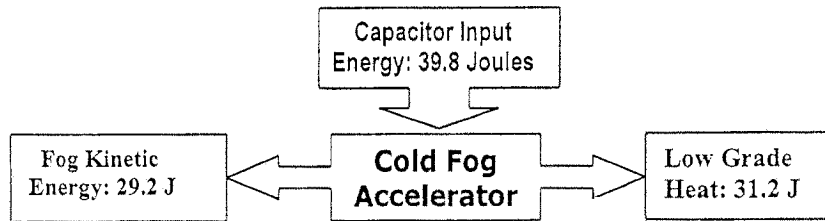

Figure 1. Cold Fog Energy Flow

#### BETAVOLTAIC BATTERY

The next technology of importance is the betavoltaic battery invention of Dr. Paul Brown (U.S. Pat. 4,835,433). It involves a benign nuclear source called tritium (an isotope of hydrogen) that simply emits an electron (5.7 keV beta particle) over its half life of 12.5 years. The useful battery life is thus estimated to be about 25 years. It is a cheap, long-life, high energy density battery with a wide range of applications. Presently, Lucent Technologies has been contracted to produce the tritiated amorphous silicon for use in the semiconductor industry and even for watch batteries. The amorphous silicon is placed between two electrodes in order to complete the battery construction. The batteries have a mean energy density of 24 watts per kilogram and are ideal for low power, long-life applications<sup>4</sup>. It is clear that no recharging of these batteries is ever needed. The disposal is even safer than disposing of smoke detectors.

<sup>3</sup>Hathaway, Graneau, and Graneau, “Solar–Energy Liberation from Water by Electric Arcs”, *J. Plasma Physics*, Vol. 60, Part 4, p. 775–86. [ghathaway@ieee.org](mailto:ghathaway@ieee.org)

<sup>4</sup>Brown, Paul, “Betavoltaic Batteries” and “Effective Radioactive Waste Remediation,” Proceedings of the First International Conference on Future Energy, (Proceedings of COFE), p. 19 & 123, Integrity Research Institute, 1999, ISBN 0–9641070–3–1 (Alternatively, COFE CD–Proceedings on CD–ROM has 20 hours of lectures added in digital audio.) Brown’s email: [brown@fissionfuels.com](mailto:brown@fissionfuels.com)



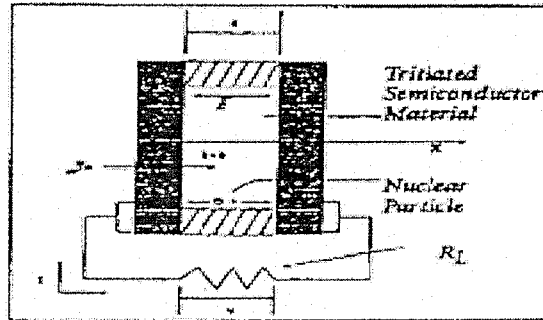

Figure 2. Tritium Battery

## NUCLEAR REMEDIATION

It is worthwhile mentioning that Dr. Brown's other endeavor may give a boost to the nuclear power industry. He has discovered that low energy gamma rays (photons) on the order of 10 MeV, can function as an effective agent to transmute nuclear waste into short-lived isotopes, acceptable for burial anywhere. The remediation project is spear-headed by International Fission Fuels, Inc. which plans to build a pilot plant to accept nuclear waste of any type and generate electricity at the same time. The Battelle Institute, Brookhaven Labs, and Los Alamos Labs have all been involved in the planning and testing stages of this new technology. Dr. Brown presented details of this invention at COFE. Also, the State Department recently connected him with foreign markets that have assisted in proving its worth.

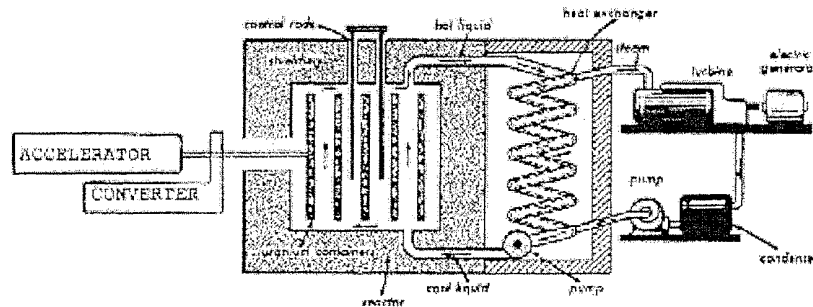

Figure 3. Accelerator Driven Reactor

## ELECTROSTATIC MOTORS

The next energy breakthrough is Dr. Oleg Jefimenko's electrostatic motors. Discovered by Ben Franklin in the 18th century, electrostatic motors are an all-American invention. They are based on the physics of the fair-weather atmosphere that has an abundance of positive electric charges up to an altitude of 20 km. However, the greatest concentration is near the ground and diminishes with altitude rapidly. Dr. Jefimenko discovered that when sharp-pointed antennas are designed for a sufficient length to obtain at least 6000 volts of threshold energy, the fair-weather current density available is about a picoampere per square meter. Such antennas produce about a microampere of current. However, small radioactive source antennas may be used instead that have no threshold voltage and therefore no height requirements. Similar to a nuclear battery design of Dr. Brown, these antennas have larger current potentials depending upon the radioactive source used (alpha or beta source) and ionize the air in the vicinity of the antenna. Electrostatic motors are

lighter than electromagnetic motors for the same output power since the motor occupies the entire volume. For example, it is expected that a motor one meter on a side will provide a power of one megawatt and weigh 500 kg or less. Electrostatic motors also require very little metal in their construction and can use mostly plastic for example. They can also operate from a variety of sources and range of voltages. As Dr. Jefimenko points out, "It is clear that electrostatic motor research still constitutes an essentially unexplored area of physics and engineering, and that electrostatic motor research must be considered a potentially highly rewarding area among the many energy-related research endeavors."<sup>5</sup> The atmospheric potential of the planet is not less than 200,000 megawatts. He has succeeded in constructing demonstration motors that run continuously off atmospheric electricity. Jefimenko's largest output motor was an electret design that had a 0.1 Hp rating.<sup>6</sup> Certainly the potential for improvement and power upgrade exists with this free energy machine.

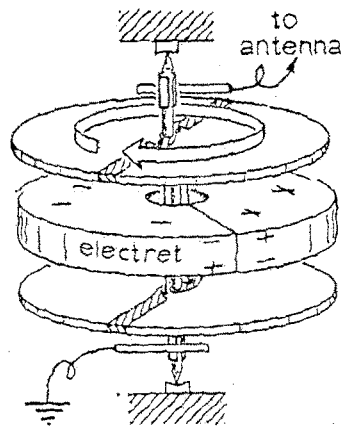

Figure 4. Electrostatic Motor Model

#### BIOMASS GASIFICATION

Clean fuels are difficult to find today. One example that satisfies a limited definition of "clean" is the carbo-hydrogen gas produced from biomass. David Wallman has patented the process for producing  $\text{COH}_2$  from a high voltage discharge through any biomass solution (Pat. No. 5,417,817). This gas burns cleanly, producing water vapor and only the amount of  $\text{CO}_2$  that was originally absorbed by the biological mass when it was growing in the ground. Contrast this with burning fossil fuels (oil and natural gas) which resurrect old buried carbon and add it to the atmosphere from ancient cemeteries in the ground.

<sup>5</sup> Jefimenko, Oleg, "Electrostatic Energy Resources, Electrostatic Generators, and Electrostatic Motors," Proceedings of COFE, p. 195

<sup>6</sup> Jefimenko, Oleg, Electrostatic Motors, Electret Scientific Co., Star City, WV, 1973 (future editions to be published by Integrity Research Inst.)



Figure 5. Gasification Demo  
Photo: Alternative Energy Institute

Instead, biomass gas burning recycles recently absorbed atmospheric carbon dioxide. The input energy is typically about a thousand watt-hours or about 3300 BTU to produce about 250 liters per hour of carbo-hydrogen (8.5 cubic feet per hour). With a heating value of over 500 BTU per cubic feet, the  $\text{COH}_2$  output energy exceeds 4000 BTU, often approaching 5000 BTU in high efficiency designs. Thus, this biomass gasification process has an overunity efficiency of about 125 percent to 150 percent. However, when the entire energetics of the system are accounted for, including the ultraviolet light radiation, heat loss, etc., estimates of 200 percent to 400 percent are reasonable. Again, this process is a largely untapped resource while millions of gallons of farm-produced liquid biomass going to waste instead. Demonstrations of pilot plant designs are available from Wallman's company to replace present dependence on foreign oil (which is a fossil fuel). Municipal sewage treatment is a logical application for this invention.<sup>7</sup>

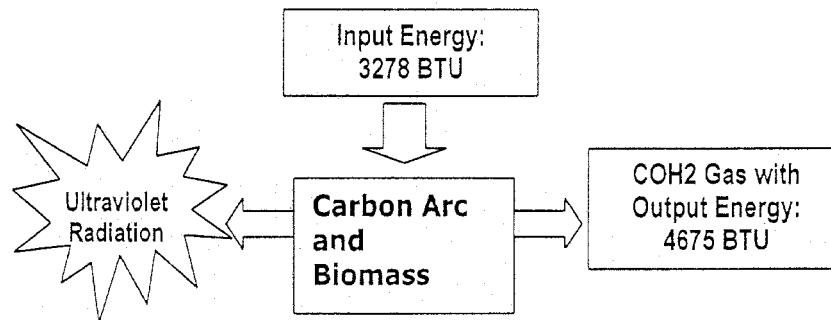

Figure 6. Biomass Gasification

<sup>7</sup>Wallman, David, "Carbon Arc Gasification of Biomass Solutions," Proceedings of COFE, p. 30. (1350 Northface Ct., Colorado Springs, CO 80919) [WD.Wallman@worldnet.att.net](mailto:WD.Wallman@worldnet.att.net)

## CHARGE CLUSTERS

An unusual energy source is the clustering of electrons by a discharge needle into a high density bundle equaling Avogadro's density of a solid<sup>8</sup>. Ken Shoulders has patented a process (Pat. No. 5,153,901) that produces electron clusters with such high energy density, they equal processes exceeding 25,000 degrees Celsius upon impact. Yet, he only uses 20 microjoules to produce the effects. The clusters travel at a maximum of one tenth of the speed of light and penetrate any substance with accuracy and sharp precision. It is similar to xenon clustering techniques currently used at megavolt energy levels. Low energy nuclear transmutation of the target has also been achieved with this process. Using a deuterium loaded palladium foil, only the bombardment areas show transmutation into silicon, calcium, and magnesium with electron clusters upon analysis with X-rays. Fox has postulated that the high velocity electron clusters achieve results similar to ion accelerators, including penetration of the nucleus, with substantially less power. The new physics of like-charges clustering in bundles under low power conditions opens a wide range of applications including spacecraft maneuvering microthrusters. The overunity efficiency is 9-to-1.

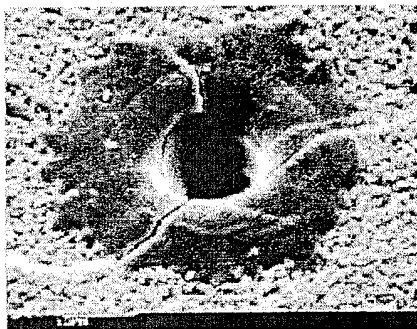

Figure 7. Charge cluster borehole into lead glass. Hole is about 10 micron diameter. Penetration is about 1 mm per kV. The lowest speed clocked has been 1 cm in 50 nanoseconds. With an estimated 100 billion electrons carrying 100,000 positive ions, the kinetic energy exceeds 180 microjoules. It has been suggested that a Casimir effect pushes them together, overcoming Coulomb repulsion of like charges. (photo credit: Ken Shoulders)

## THIN-FILM ELECTROLYTIC CELL POWER UNIT

A product with the consumer in mind is Dr. George Miley's invention that produces about one watt per cubic centimeter of electrolyte<sup>9</sup>. Using a flowing packed-bed type electrolytic cell with 1-molar  $\text{LiSO}_4$  in light water, small (1-mm diameter) plastic beads with a thin (500–1000 angstrom) film of metal (nickel, palladium, or titanium) are employed. A special sputtering technique to spray on the metal is used. With 2–3 volts of electrical power and only 1–5 milliamperes of current, the single film experiments produce an excess power *10 times* the input power! (The input power is at most 0.01 watts while one half of a watt of heat is produced.) Observed power densities were 1 W/cc and above. It is also apparent that the physics of this reaction involve nuclear transmutations as well. As Dr. Miley notes: "The key finding from these studies has been the observation of a large array of "new" elements (i.e. different from the bead coating), many with significant deviations from natural isotopic compositions, after the run. Great care has been made to insure that these elements are distinguished from isotopic impurities by use of a "clean cell" with high purity components/electrolyte, in addition to the pre- and post-run

<sup>8</sup>Shoulders, Ken and Steve, "Charge Clusters in Action", Proceedings of COFE, p. 7 (P.O. Box 243, Bodega, CA 94922) email: [krscfs@svn.net](mailto:krscfs@svn.net) and *Infinite Energy*, "Charge Clusters in Operation," Jan–Feb, 1997, p. 62

<sup>9</sup>Miley, George, "Emerging Physics for a Breakthrough Thin-Film Electrolytic Cell Power Unit", AIP Conference Proceedings 458, STAIF 1999, p. 1227–31. Reproduced with permission in Proceedings of COFE, p. 140. email: [g-miley@uiuc.edu](mailto:g-miley@uiuc.edu)

analyses.” Even low-energy radiation was detected from the beads days after each experiment. Application to space power, providing a 1-kW cell with only 500 cc of active electrode is predicted. Note that this particular invention, with its large overunity energy yield, was awarded a NERI grant by the DOE but then promptly withdrawn after certain individuals pressured the DOE into a re-evaluation of its grant to Professor Miley. The politics that override such grant decisions by the DOE Office of NEST are highly questionable.

#### CONCLUSION

Future energy choices are already here. In spite of the DOE lack of initiative in long range energy solutions, private inventors in this article have pioneered energy discoveries with a range of energy production possibilities. With Dr. Graneau’s cold fog demonstrating a new energy source and a possible propulsion source, developmental efforts are ongoing with Hathaway Labs in Toronto to maximize the energy transfer to a useful machine for market. Dr. Brown’s tritium battery is a milestone for long-term energy demand that is in production, while his nuclear remediation project is progressing rapidly. Dr. Jefimenko’s electrostatic motors clearly demonstrate an available energy source yet untapped. Wallman’s biomass gasification is ready to be developed on a large scale. Shoulder’s charge clusters demonstrate extraordinary energy production on a microscopic scale with reasonable upscaling anticipated. Dr. Miley’s electrolytic power unit also shows an extraordinary energy output, which deserves more research and development support. Other inventors that meet the future energy criteria include Dr. Deborah Chung, from the State University of N.Y. at Buffalo, who has discovered “negative” resistance in carbon fibers.<sup>10</sup> Another, James Griggs, the inventor of the hydrosonic pump (Pat. No. 5,385,298), represents an overunity “apparatus for heating fluids” which even exhibits sonoluminescence (now marketed by HydroDynamics in Rome, Georgia). Dr. Paulo Correa also qualifies with his pulsed abnormal glow discharge (PAGD) energy conversion system.<sup>11</sup> It is our belief that all of these inventions have the qualifications to be acceptable to energy futures. Also, theoretically and experimentally, there is growing support for a breakthrough in zero point energy conversion,<sup>12</sup> which is the subject of more than one patent, the most recent being Dr. Frank Mead’s patent No. 5,590,031. Furthermore, the extraction of energy and heat from the vacuum has also been proposed by Drs. Harold Puthoff and Daniel Cole.<sup>13</sup> Certainly, if only the 2.6 percent disruption in the oil flow from the Mid-East in 1999 can cause immediate chaos in the gasoline prices in this country, we desperately need to cut the umbilical cord strangling us. Therefore, a more robust energy development effort is required to help us make the transition from dangerous fossil fuels. A more stable, long-term energy future is possible with new energy sources like these discussed in this article.

---

#### MOVING BEYOND THE FIRST LAW AND ADVANCED FIELD PROPULSION TECHNOLOGIES

(By: Paul A. LaViolette, Ph.D.)

##### 1. THE REPRESSION OF NONCONVENTIONAL ENERGY TECHNOLOGIES

According to U.S. patent law, a patent has the right to be issued if the technology is new and if it works. There is nothing in the legal code that says that the patent necessarily has to conform to theories of physics or chemistry as they happen to be defined by certain academic science societies. Unfortunately, administrators of the U.S. Patent and Trademark Office (PTO) have been illegally blocking the issuance of patents on new technologies that challenge current scientific thinking. This discrimination is often carried out in response to lobbying by Robert Park, who is Director of Public Information of the American Physical Society (APS), and by his affiliates. The process usually begins with media smear campaign aimed at defaming the inventors of nonconventional technologies or at embarrassing PTO examiners who hold scientific views they disagree with. Then this group of lobbyists email these media attacks to PTO administrators, or they may call up PTO officials with

<sup>10</sup> Chung, Deborah, SUNY at Buffalo, 608 Furnas Hall, Buffalo, NY 14260

<sup>11</sup> Correa, Paulo, “Excess Energy Conversion System Utilizing Autogenous Pulsed Abnormal Glow Discharge,” *Proceedings of COFE*, p. 150 (Labofex Laboratory, 42 Rockview Gardens, Concord, Ontario L4K 2J6) email: [lambdac@globalserve.net](mailto:lambdac@globalserve.net)

<sup>12</sup> Valone, Thomas, “Understanding Zero Point Energy,” *Proceedings of COFE*, p. 58

<sup>13</sup> Cole and Puthoff, “Extracting energy and heat from the vacuum,” *Physical Review E*, vol. 48, No. 2, August 1993.

whom they have developed close associations to voice their dissatisfaction. The PTO administrators then respond in a knee jerk fashion to this outside pressure to either make sure that certain patents don't issue or to reprimand or even fire examiners who take an open minded approach to considering such new technologies.

An example is the BlackLight Power Corp. case. BlackLight's inventor Randall Mills has developed a process for producing large amounts of energy from normal tap water. This is the kind of technology that we need to solve the present energy crisis. The reality of this technology has been independently verified by other scientific laboratories. Yet, Mills and his company have been repeatedly attacked by this APS lobby through Robert Park's news postings on the society website, derisive editorials written in mainstream science magazines, in lectures at the 1999 APS annual meeting, and even in a book authored by Park. Because this technology challenges the currently popular theories of physics, this lobby has unjustly branded it as being fraudulent. PTO administrators obediently responded to this outside pressure by unlawfully withdrawing one of BlackLight's patents after it had already been slated to issue in February 2000. One of the PTO officials who was involved in taking this action has admitted that they did this in response to media attacks leveled against BlackLight. The company is now suing the Department of Commerce for this travesty of justice.

Another example concerns a patent awarded in February 2000 on an invention capable of sending communications faster than the speed of light. Witnesses attested that the invention worked as claimed. Yet shortly after the patent had issued, believing that the invention violated the theory of special relativity, Park posted a news item on the APS website which made fun of the PTO for having issued the patent. Arrangements were even made to have one patent website proclaim it to be the most ridiculous patent of the year. Papers published in refereed physics journals have described laboratory experiments in which waves have been made to travel faster than the speed of light. Yet disregarding this evidence, the Commissioner decided to side with the APS lobbyists. He severely reprimanded the patent examiner who had issued the patent and also threatened to fire his supervisor.

Also there is the case of the firing of two patent examiners, Tom Valone and Paul LaViolette. Park and the APS lobby had been ridiculing them because they had an interest in nonconventional energy technologies and because they were involved in organizing a conference that included papers on nonconventional energy technologies. They attacked the examiners in postings on the APS website, in magazine editorials, and in lectures presented at the 1999 annual APS meeting where they admitted to their ongoing efforts to secure the removal of anyone at the PTO who sympathized with cold fusion technology. They also initiated an email campaign to PTO officials as well as made personal contacts with PTO officials. Within a day of this email blitz, Paul LaViolette was given notice of termination and proceedings were begun against Tom Valone which resulted in his removal 5 months later. Both examiners at the time had a commendable record of job performance. Both examiners now have Justice Department litigation pending on this matter.

As a result of similar discrimination, government research moneys are routinely withheld from companies or individuals trying to develop such cutting edge ideas. In the name of preserving an outmoded set of theories that they claim their particular view. Government officials need to recognize that a working technology should not be suppressed just because it lies outside of the current scientific paradigm and produces results that refute that paradigm. The goal should be to solve society's problems, not to reaffirm outmoded theories espoused by today's enfranchised physicists and chemists.

## 2. THE NONCONVENTIONAL ENERGY TECHNOLOGY BILL OF RIGHTS

Nonconventional technologies may be our only hope for solving the problems that presently lie ahead of us, but they are currently the underdog. We need an affirmative action program to educate government agencies and mainstream media to develop a more positive attitude toward nonconventional technologies, to treat the researchers of these technologies in a fair manner, and to stop engaging in witch hunts. If we are going to deal with the problems we face, the scientific community needs to make a radical paradigm shift. They have to adopt a radically different attitude with respect to what is possible and what is not. There is not much time.

## 3. THE FIRST LAW OF THERMODYNAMICS IS NOT INVIOABLE

The First Law of Thermodynamics states that energy may be neither created nor destroyed. But there is evidence that nature routinely violates the First Law.

*Energy creation:* The discovery that the jovian planets (Jupiter, Saturn, Uranus, and Neptune) lie along the same luminosity trend line as stars of the lower main

sequence (e.g. red dwarfs) throws a monkey wrench into theories of how stars generate their energy. Nuclear energy cannot explain this correspondence. One very simple solution to this problem is that a photon's energy is not constant, that photons inside celestial bodies slowly blue shift—increase their energy over time. Thus energy is being continuously created in stars throughout the universe. This so called “genic energy” emerges as a prediction of a new physics methodology called sub-quantum kinetics. Since red dwarfs make up most of the stars in our Galaxy, as a rule genic energy may be the dominant energy creation mechanism. Nuclear energy becomes important only in the much rarer, massive stars such as our Sun. Consequently, most of the stars in the universe may be run on “free energy” in violation of the First Law.

Although this rate of energy creation is ten orders of magnitude smaller than what can be detected in laboratory experiments, it nonetheless weakens the arguments of those who maintain that the First Law is an inviolable doctrine of nature. If nature violates it, why can't we violate it also? Physics needs to make a major shift in thinking, shed their linear models which predict that there is no such thing as a free lunch, and embrace the newly emerging nonlinear models which allow the possibility that matter and energy may be created and destroyed.

#### 4. GRAVITY FIELD PROPULSION IS REAL: TOWNSEND BROWN'S TECHNOLOGY OF ELECTROGRAVITICS

In the mid 1920s, Townsend Brown discovered that electric charge and gravitational mass are coupled. He found that when he charged a capacitor to a high voltage, it had a tendency to move toward its positive pole. This became known as the Biefeld–Brown effect. His important findings were opposed by conventional minded physicists of his time.

*The Pearl Harbor Demonstration.*—Around 1953, Brown conducted a demonstration for top brass from the military. He flew a pair of 3 foot diameter discs around a 50 foot course tethered to a central pole. Energized with 150,000 volts and emitting ions from their leading edge, they attained speeds of several hundred miles per hour. The subject was thereafter classified.

*Project Winterhaven.*—Brown submitted a proposal to the Pentagon for the development of a Mach 3 disc shaped electrogravitic fighter craft. Drawings of its basic design are shown in one of his patents. They are essentially large scale versions of his tethered test discs.

*Aviation Studies International.*—They are a think tank that produces intelligence studies for the military. In 1956 they issued a report entitled “Electrogravitics Systems” which called for major government funding to develop Townsend Brown's electrogravitics technology and make Project Winterhaven a reality. The report stated that most of the aerospace was actively researching this antigravity technology. It named companies such as: Glenn–Martin, Convair, Sperry–Rand, Bell, Sikorsky, Douglas, and Hiller. Other companies who entered the field included Lockheed and Hughes Aircraft, the latter being regarded by some as the world leader in the field. This report was initially classified. It was missing from the Library of Congress collection. Their staff made a computer search and found that the only other known copy was located at Wright Patterson Air Force Base. I obtained it from there through interlibrary loan. It is now published in the book *Electrogravitics Systems*, T. Valone (editor).

*Northrop's Wind Tunnel Tests.*—In 1968, engineers at the Northrop Corp. performed wind tunnel tests in which they charged the leading edge of a wing to a high voltage. They were investigating how this technique could be used beneficially to soften the sonic boom of aircraft. Hence they were performing large scale tests on Brown's electrogravitic concept. Brown's R&D company had previously made known that sonic boom softening would be a beneficial side effect of this electrogravitic propulsion technique. Interestingly, Northrop later became the prime contractor for the B–2 bomber.

*The B–2 Bomber.*—In 1992, black project scientists disclosed to *Aviation Week and Space Technology* magazine that the B–2 electrostatically charges its exhaust to a high voltage and also charges the leading edge of its wing-like body to the opposite polarity. This information led Dr. LaViolette in 1993 to reverse engineer the B–2's propulsion system. He proposed that the B–2 is essentially a realization of Townsend Brown's patented electrogravitic aircraft. The B–2 is capable of taking off under normal jet propulsion. But when airborne, its electrogravitic drive may be switched on for added thrust. This system can only be turned on under dry conditions. If the B–2's dielectric wing were to become wet, the applied high voltage charge would short out, which explains why the B–2 is unable to fly in the rain.

With electrogravitic drive, the B-2 is able to drastically cut its fuel consumption, possibly even to zero under high speed flight conditions.

The commercial airline industry could dramatically benefit with this technology which would not only substantially increase the miles per gallon fuel efficiency of jet airliners, but would also permit high-speed flight that would dramatically cut flight time.

*Subquantum Kinetics Predicts Antigravity Effects.*—General relativity doesn't explain the Biefeld-Brown electrogravitic effect or any other antigravity phenomenon since it predicts that masses have just one gravitational polarity and should only attract one another. It allows the possibility of charge-mass coupling, only at very high energies, such as those attainable in particle accelerators far more powerful than any thus far built. The subquantum kinetics physics methodology, however, offers a much needed answer to the insufficiencies of relativity. It predicts that gravitational mass should have two polarities (+ and -) and that these mass polarities should be correlated with the charge polarity of a particle. According to subquantum kinetics, Brown's electrostatic disc should establish a gravitational field gradient from front to back which has the effect of propelling the disc forward. The movement of the charges may contribute an even larger thrust effect. The same would apply to the B-2 bomber.

##### 5. OTHER ADVANCED AEROSPACE PROPULSION TECHNOLOGIES

*The Searl Electrogravity Disc and Russian Experiments.*—This device, developed over 40 years ago by the British engineer John Searl, consisted of a segmented rotating disc each of whose segments was supported by a set of cylindrical permanent magnets rolling within a circumferential track. It is alleged to have achieved complete lift off. In the past few years two Russian scientists associated with the Russian National Academy of Sciences, Roschin and Godin, have built a simplified version of the Searl Disc that confirms its anomalous weight loss effects. They spun a 1 meter diameter disc at 600 rpm and obtained a 35 percent reduction in its weight while at the same time generating a 7 kilowatt excess electric power output.

*The Podkletnov Gravity Shield and Project Greenglow.*—A research team in Finland led by Dr. Podkletnov were experimenting with a rotating superconducting disc that was floated on a repelling magnetic field generated by a series of electromagnets. In 1996, they reported that the disc was able to partially screen the Earth's gravitational field, reducing the weight of objects positioned above the disc by 2 percent. Greater weight reductions are envisioned by stacking several discs over one another. Besides propulsion, there are obvious applications to tapping the resulting gravity differential for mechanical power generation. In the last few years, BAE Systems a company formed by the merger of British Aerospace with Marconi Electronic Systems, has been researching the Podkletnov gravity shield. They are doing this work under Project Greenglow, a project they have set up to investigate the feasibility of nonconventional technologies.

*The De Aquino Antigravity Effect.*—A Brazilian university professor, Fran De Aquino, has produced a 50 percent weight reduction in a 2 foot diameter, annealed pure iron toroid weighing 77 pounds. He does this by internally energizing the toroid with 10 kilowatts of 60 cycle electromagnetic radiation. His data predicts complete weightlessness of the toroid could be achieved with a 15 kilowatt power input.

*Gravito Inertial Lift System.*—Aerospace engineer Jim Cox has recently improved on the Dean Drive, an inertial propulsion engine that was patented in May 1959. He reports tests demonstrating an upward thrust equal to 90 percent of the engine's weight. It uses a ¼ horsepower motor to revolve two counter-rotating rotors, each about 1 cm in diameter, spinning them at about 600 rpm for a power consumption of about 200 watts. The lift is gotten by sinusoidally oscillating the rotors up and down and coupling them to the lift platform on their upward stroke. He obtains about 45 pounds of lift force per horsepower (~55 pounds/kw). He plans by the end of the year to have a freely lifting device which would be spun to 1200 rpm with a ½ horsepower motor drawing 400 watts. He estimates that using this technology a 200 horsepower automobile engine would be capable of generating a lift force of about 9000 pounds.

*Kineto-baric Field Propulsion.*—German scientist Rudolph Zinsser discovered that sawtooth electromagnetic waves could be made to push distant objects. He produced a radio tube circuit that transmitted 45 megahertz radio waves having a sharp rise and gradual fall. His experiments demonstrated that these waves could exert impulses of up to  $10^4$  to  $10^5$  dyne seconds, which is equivalent to the application of about 1 to 3 ounces of force for a period of 1 second. He found that this force could be generated with an amazingly low input power, the output-force-to-input-power



ratio surpassing that of conventional propulsion methods by several powers of 10. His projections imply a thrust of 1350 pounds force per kilowatt.

*Field Thrust Experiments on Piezoelectrics.*—James Woodward, a physics professor at Cal State Fullerton, is conducting research that indicates that electromagnetic waves can induce lofting forces in piezoelectric ceramic media. His ideas are described in a 1994 U.S. patent and in a 1990 physics journal article. Woodward has conducted experiments that confirm this thrust effect in the audio frequency range (~10,000 Hertz), and his calculations suggest that it may be substantially increased at higher frequencies, with optimal performance being obtained in the microwave range (0.1 to 10 gigahertz). His work has gotten some support from DoE.

ACCOUNTABILITY AND RISK IN THE INFORMATION ERA: LESSONS DRAWN FROM THE  
“COLD FUSION” “FUROR”

(By: Dr. Scott Chubb, Naval Research Laboratory)

BACKGROUND

Nature does not lie. But it can fool us. Also, we frequently fool ourselves. When media attention, the politics of money and prestige, the possibility of extraordinary wealth, and the fear of embarrassment also become part of the equation, the resulting situation can rapidly escalate into a minefield of confusion. For this reason, “taking risks,” especially about areas involving science and technology, always can be dangerous. When opinion becomes part of the process, risk-taking can take on an identity of its own.

An extreme example of this occurred 11 years ago when Stanley Pons and Martin Fleischmann (PF) took an “extraordinary risk” by “implying” it was possible to “create a room-temperature hydrogen bomb in a test-tube.”<sup>1</sup> Almost immediately, their “suggestion” “for new research” “not only ‘was discredited,’” but with time, scorn and ridicule (even open harassment) routinely became part of the lives of individuals who have paid attention to it.<sup>2</sup> However, despite the apparent meltdown, in public opinion, about Cold Fusion (CF), CF research has continued. An obvious question is why?

WHAT’S NEW

Clearly, one might ask one of two questions: 1. “Are those who remained involved fooling nature or themselves?” or 2. “Are those who are responsible for harassing those who have remained involved been fooled?” In fact, at the core of both questions are two key issues: 1. The degree that individuals (or groups of individuals) can take “risks” and also avoid “appearing” to be “foolish”, or when or how (as a result of policy decisions, for example) can the “perception of appearing to be foolish” be “augmented” in a useful way to such a degree that a “useful” way “to be foolish” can occur, or 2. How, given the need to satisfy budget constraints and be “persuasive and credible”, do we deal with ideas that are difficult to accept?

Recently, while serving as guest editor of an Ethics in Science journal, titled “Accountability in Research,”<sup>3</sup> I dealt with this issue. Specifically, I asked a number of senior individuals on both sides of the Cold Fusion debate to deal with the following question: regardless of whether or not Cold Fusion (CF) claims have merit, were (or are) there lessons that can be learned from the on-going situation? Almost universally, the various authors agreed on three general ideas: 1. “Normal” scientific discussion about CF ended at a very early stage, 2. The “breakdown” of “Normal” scientific discussion not only has not been widely accepted outside the field, but 3. Although the reasons for this “breakdown” are not clear, the “failure” by particular “individuals” or “institutions” to be held “accountable” for past actions has been

<sup>1</sup>This quote paraphrases comments from a number of popular sources of information (the popular press, newspapers, etc). It typifies the kind of imprecise, anecdotal information about Cold Fusion that, somewhat surprisingly, is still commonly believed to have been attributed to Pons and Fleischmann, and Jones et al. In fact, compelling evidence exists that novel forms of nuclear reaction exist, without high energy particles; <http://www.infinite-energy.com>.

<sup>2</sup>Charles G. Beaudette, *Excess Heat: Why Cold Fusion Research Prevailed*. (Oak Grove Press, LLC, ME, 2000). (ISBN 09678548-06; available through <http://www.amazon.com>, <http://www.infinite-energy.com>; hardcover \$36.95; softcover \$26.95, distributed by INGRAM and Infinite-Energy Press).

<sup>3</sup>Scott R. Chubb, “Introduction to the Special Collection of Articles in Accountability in Research Dealing With Cold Fusion”, in *Accountability in Research*, v. 8, 1 and 2. (eds. A.E. Shamoo, and S.R. Chubb, Gordon and Breach, Philadelphia, 2000). (<http://www.gbhap-us.com/journals/149/149-top.htm>).

largely responsible for this problem. Implicit in these assertions is an obvious point. "Cold Fusion" "was" "and is" a "risky" "form" of "science." "Discussions about CF" have "ceased" "to be" "normal" "for precisely this reason." But there is a more poignant message: despite the fact that research in CF has continued, not only have the initial "critics" largely avoided the subject, even though many of their criticisms have been adequately addressed, most scientists are simply unaware of this fact. An important reason for this is that many of the institutions that are involved either in disseminating information about science or in adjudicating science have largely ignored what has been going on.

#### IMPACT

There is an important lesson associated with this that applies not only in science, but in most forms of human interaction. For communication to occur, some form of accountability is necessary. (This is especially true when risk is involved.) Institutions and individuals must be held accountable for their actions for an obvious reason: the need to maintain trust. Specifically, when a particular party or group requests that an individual or institution be held accountable for a particular action, implicitly, trust occurs. This is because at a very basic level, for communication to occur at all, it is necessary that the parties mutually trust each other. The process of assigning accountability for a particular action involves the identification of a particular liability (or responsibility) that can be directly associated with a particular action. When the associated liability or responsibility is clearly identifiable, the degree of accountability can be quantified. Because in situations involving risk, the associated liability can be difficult to define, procedures for assigning accountability become less tangible.

In "normal" circumstances, "liability" and "responsibility" and "accountability" not only can all be identified and related to each other but can be quantified either by precedent or through the potential for pecuniary damages or rewards (as defined through the marketplace, for example). Thus, typically, accountability can be measured using flows of information, ideas, money, or technology, almost in terms of a marketplace type of scenario. Then "liability" and "responsibility" can be defined in terms of how these processes are enhanced or impeded by a particular set of actions. When "risk" becomes part of the "scenario", however, this picture becomes altered, significantly.

For this reason, within the context of "normal" science, it is relatively easy to identify the terms of accountability. However, when the relevant "science" ceases to be "normal," because of "risk," the terms associated with accountability cease to be as clearly defined. In fact, "risk" "as it applies to CF", in a grander context, also applies to "bold" or "new" initiatives. And many of the lessons from the CF controversy involving "risk" can be viewed as having more-far-reaching lessons associated in policy-decisions involving a particular individual or groups of individuals.

Ironically, in the case of CF, the advent of Information Era technologies seems to have eroded the underlying communication problem. In particular, at an early stage, considerable confusion occurred as a result of the widespread dissemination of incomplete (and incorrect) information about the associated experiments, by FAX machines, and through the Internet. The resulting "discourse" quickly became distorted. This situation not only seriously undermined the scientific review process but seems to have been at least partly responsible for the fact that established scientific journals do not publish information about CF.

In the talk, I will summarize my involvement with CF, as well as several important conclusions that I have summarized in my Introduction to the special two issue collection of articles from the Ethics in Science journal, Accountability in Research, where a number of senior individuals involved in the controversy have examined the associated breakdown in scientific dialog, about this topic. Important implications of the work include the need for greater investment in Science in "formal" and "informal" "ways". In particular, it is apparent that a "rush-to-judge" mentality was present in 1989 that clearly was related to funding (or loss of funding). This not only included a number of "obvious 'non-scientific' events", and "reviews" involving a number of organizations (most notably the American Physical Society, the Department of Energy, and the Patent Office)" but other actions, including non-scientific intervention (involving the American Physical Society and the Department of Energy) that appear to have been prompted by a lack of sufficient funding.

The effect of this process is simple: after 11 years, not only have the relevant scientific issues not been adequately represented, serious questions about the adjudication process that is responsible for this should be addressed. The Congress, the President, and the Courts are the final bodies that "should be held 'accountable,'" with regard to these issues. Science cannot be objective when the "bodies" "that

'hold' 'Science' 'captive'" are not willing to "investigate" "Science." It is not only plausible but likely that others, besides those involved with the government, will be assigned "blame" "for injustices" associated with "Cold Fusion." However, I believe this view is shortsighted. In my opinion, the institutions mirror investment. Scientists will only feel free to take risks when they are sufficiently protected to do so. In 1945, we felt compelled to "protect science." In 2000, this seems to be a forgotten message. Innovative Energy ideas, "risky ideas" (which "wouldn't be 'so risky' if scientists had adequate funding") are left unexplored, as a consequence.

---

THE STRANGE BIRTH OF THE WATER FUEL AGE: THE COLD FUSION "MIRACLE" WAS  
NO MISTAKE

Dr. Mallove's briefing paper, which was submitted on request from the White House for President Clinton (Feb., 2000) was not available at the time of this compilation, but may be obtained from him at: Infinite Energy Magazine, P.O. Box 2816, Concord, NH 03302, Phone: 603-228-4516.

---

THE UNNECESSARY ENERGY CRISIS: HOW TO SOLVE IT QUICKLY

(T.E. Bearden, LTC, U.S. Army (Retired) CEO, CTEC Inc.)

INTRODUCTION

THE WORLD ENERGY CRISIS

*The world energy crisis is now driving the economies of the world nations.*

There is an escalating worldwide demand for electrical power and transportation, much of which depends on fossil fuels and particularly oil or oil products. The resulting demand for oil is expected to increase year by year. Recent sharp rises in some U.S. metropolitan areas included gasoline at more than \$2.50 per gallon already.

At the same time, it appears that world availability of oil may have peaked in early 2000, if one factors in the suspected Arab inflation of reported oil reserves. From now on, it appears that oil availability will steadily decline, slowly at first but then at an increasing pace.

Additives to aid clean burning of gasoline are also required in several U.S. metropolitan areas, increasing costs and refinery storage and handling.

The increasing disparity between demand and supply—steadily increasing demand for electricity using oil products versus decreasing world supplies of oil, with other factors such as required fuel additives—produces a dramatically increasing cost of oil and oil products. Further, newer supplies of oil must be taken by increasingly more expensive production means.

Manipulative means of influencing the price of oil include (i) the ability of OPEC to increase or decrease production at will, and (ii) the ability of the large oil companies to reduce or increase the holding storage of the various oil products, types of fuel, etc. Interestingly, several large oil companies are reporting record profits.<sup>1</sup>

At the same time, the burgeoning populaces of the major petroleum producers—and their increasing economic needs—press hard for an increasing inflation of oil prices in order to fund the economic benefits.

As an example, Saudi moderation of OPEC is vanishing or has already vanished. The increasing demands of the expanding Saudi Royal Family group and the guaranteed benefits to the expanding populace have overtaken and surpassed the present Saudi financial resources unless the price of OPEC oil is raised commensurately.<sup>2</sup>

The Federal Reserve contributes directly to the economic problem in the United States, since it interprets the escalating prices of goods and services (due to escalating energy prices) as evidence of inflation. It will continue to raise interest rates to damp the economy, further damping U.S. business, employment, and trade. The Fed has already increased interest rates six times in 1 year as of this date.

INTERNATIONAL TRADE FACTORS

Under NAFTA, GATT,<sup>3</sup> and other trade agreements, the transfer of production and manufacturing to the emerging nations is also increasing and trade barriers are lowered. Some 160 emerging nations are essentially exempt from environmental pollution controls, under the Kyoto Accords. In these nations, electrical power needs and transport needs are increasing, and will continue to increase, due to the increasing production and movement of goods and the building of factories and assem-

bly plants. Very limited pollution controls—if any—will be applied to the new electrical plants and transport capabilities to be built in those exempted nations.

The transfer of manufacturing and production to many of these nations is a transfer to essentially “slave labor” nations. Workers have few if any benefits, are paid extremely low wages, work long hours, and have no unions or bargaining rights. In some of these nations, to pay off their debts many parents sell their children into bondage for manufacture of goods, with 12 to 14 hour workdays being a norm for the children.<sup>4</sup> In such regions the local politicians can usually be “bought” very cheaply so that there are also no effective government controls. Such means have set up a de facto return to the feudalistic capitalism of an earlier era when enormous profits could be and were extracted from the backs of impoverished workers, and government checks and balances were nil.

The personal view of this author is that NAFTA, GATT, and Kyoto were set in place for this very purpose. As the transfer builds for the next 50 years, it involves the extraction of perhaps \$2 trillion per year, from the backs of these impoverished laborers. It would not appear accidental that Kyoto removed the costly pollution control measures from this giant economic buildup that would otherwise have been required. The result will be increased pollution of the biosphere on a grand scale.

Ironically, the Environmental Community itself was deceived into supporting the Kyoto accords and helping achieve them, hoping to put controls on biospheric pollution worldwide. In fact, the Kyoto accords will have exactly the opposite effect.

#### RESULTING WORLD ECONOMIC COLLAPSE

Bluntly, we foresee these factors—and others<sup>5-6</sup> not covered—converging to a catastrophic collapse of the world economy in about 8 years. As the collapse of the Western economies nears, one may expect catastrophic stress on the 160 developing nations as the developed nations are forced to dramatically curtail orders.

#### INTERNATIONAL STRATEGIC THREAT ASPECTS

History bears out that desperate nations take desperate actions. Prior to the final economic collapse, the stress on nations will have increased the intensity and number of their conflicts, to the point where the arsenals of weapons of mass destruction (WMD) now possessed by some 25 nations, are almost certain to be released. As an example, suppose a starving North Korea<sup>7</sup> launches nuclear weapons upon Japan and South Korea, including U.S. forces there, in a spasmodic suicidal response. Or suppose a desperate China—whose long-range nuclear missiles (some) can reach the United States—attacks Taiwan. In addition to immediate responses, the mutual treaties involved in such scenarios will quickly draw other nations into the conflict, escalating it significantly.

Strategic nuclear studies have shown for decades that, under such extreme stress conditions, once a few nukes are launched, adversaries and potential adversaries are then compelled to launch on perception of preparations by one’s adversary. The real legacy of the MAD concept is this side of the MAD coin that is almost never discussed. Without effective defense, the only chance a nation has to survive at all is to launch immediate full-bore pre-emptive strikes and try to take out its perceived foes as rapidly and massively as possible.

As the studies showed, rapid escalation to full WMD exchange occurs. Today, a great percent of the WMD arsenals that will be unleashed, are already onsite within the United States itself.<sup>8</sup> The resulting great Armageddon will destroy civilization as we know it, and perhaps most of the biosphere, at least for many decades.

My personal estimate is that, beginning about 2007, on our present energy course we will have reached an 80 percent probability of this “final destruction of civilization itself” scenario occurring at any time, with the probability slowly increasing as time passes. One may argue about the timing, slide the dates a year or two, etc., but the basic premise and general timeframe holds. We face not only a world economic crisis, but also a world destruction crisis.

So unless we dramatically and quickly solve the energy crisis—rapidly replacing a substantial part of the “electrical power derived from oil” by “electrical power freely derived from the vacuum”—we are going to incur the final “Great Armageddon” the nations of the world have been fearing for so long. I personally regard this as the greatest strategic threat of all times—to the United States, the Western World, all the rest of the nations of the world, and civilization itself.<sup>9-10</sup>

#### WHAT IS REQUIRED TO SOLVE THE PROBLEM?

To avoid the impending collapse of the world economy and/or the destruction of civilization and the biosphere, we must quickly replace much of the “electrical energy from oil” heart of the crisis at great speed, and simultaneously replace a sig-

nificant part of the “transportation using oil products” factor also. Such replacement by clean, nonpolluting electrical energy from the vacuum will also solve much of the present pollution of the biosphere by the products of hydrocarbon combustion. Not only does it solve the energy crisis, but it also solves much of the environmental pollution problem.

*The technical basis for that solution and a part of the prototype technology required, are now at hand. We discuss that solution in this paper.*

To finish the task in time, the Government must be galvanized into a new Manhattan Project<sup>11</sup> to rapidly complete the new system hardware developments and deploy the technology worldwide at an immense pace.

Once the technology hardware solutions are ready for mass production, even with a massive worldwide deployment effort some 5 years are required to deploy the new systems sufficiently to contain the problem of world economic collapse. This means that, by the end of 2003, those hardware technology solutions must have been completed, and the production replacement power systems must be ready to roll off the assembly lines en masse.

*The 2003 date appears to be the critical “point of no return” for the survival of civilization as we have known it.*

Reaching that point, say, in 2005 or 2006 will not solve the crisis in time. The collapse of the world economy as well as the destruction of civilization and the biosphere will still almost certainly occur, even with the solutions in hand.

A review of the present scientific and technical energy efforts to blunt these strategic threat curves, immediately shows that all the efforts (and indeed the conventional scientific thinking) are *far too little and far too late*. Even with a massive effort on all of the “wish list” of conventional projects and directions, the results would be insufficient to prevent the coming holocaust.

As one example, the entire hot fusion effort has a zero probability of contributing anything of significance to the energy solution in the timeframe necessary. Neither will windmills, more dams, oil from tar sands, biofuels, solar cells, fuel cells, methane from the ocean bottom, ocean-wave-powered generators, more efficient hydrocarbon combustion, flywheel energy storage systems, etc. All of those projects are understandable and “nice”, but they have absolutely zero probability of solving the problem and preventing the coming world economic collapse and Armageddon.

*Those conventional approaches are all “in the box” thinking, applied to a completely “out of the box” problem unique in world history.*

The conventional energy efforts and thinking may be characterized as essentially “business as usual but maybe hurry a little bit.” They divert resources, time, effort, and funding into commendable areas, but areas which will not and cannot solve the problem. In that sense, they also contribute to the final Armageddon that is hurtling toward us.<sup>12</sup>

*If we continue conventionally and with the received scientific view, even with massively increased efforts and a Manhattan Project, we almost certainly guarantee the destruction of civilization as we know it, and much of the biosphere as well.*

Bluntly, the only viable option is to rapidly develop systems which extract energy directly from the vacuum and are therefore self-powering, like a windmill in the wind.<sup>13</sup> Fortunately, analogous electrical systems—open systems far from thermodynamic equilibrium in their exchange with the active vacuum—are permitted by the laws of physics, electrodynamics<sup>14</sup> and thermodynamics.<sup>15</sup> Such electrical systems are also permitted by Maxwell’s equations, prior to their arbitrary curtailment by Lorentz symmetrical regauging<sup>16, 17, 20</sup>.

The *good news* was that the little mathematical trick by Lorentz made the resulting equations much easier to solve (for the selected “subset” of the Maxwell–Heaviside systems retained).

However, the *bad news* is that it also just arbitrarily discarded all Maxwellian EM systems far from thermodynamic equilibrium (i.e., asymmetrical and in disequilibrium) with respect to their vacuum energy exchange.

So the *bad news* is that Lorentz arbitrarily discarded all the permissible electrical power systems analogous to a windmill in a wind, and capable of powering themselves and their loads. All our energy scientists and engineers continue to blindly develop only Lorentz-limited electrical power systems.

*The good news is that we now know how to easily initiate continuous and powerful “electromagnetic energy winds” from the vacuum at will. Once initiated, each free EM energy wind flows continuously so long as the simple initiator is not deliberately destroyed.*

The *bad news* is that all our present electrical power systems are designed and developed so that they continually kill their “energy winds” from the vacuum faster than they can collect some of the energy from the winds and use it to power their loads.

But the *good news* is that we now know how to go about designing and developing electrical power systems which (i) initiate copious EM energy flow “winds” in the vacuum, (ii) do not destroy these winds but let them continue to freely flow, and (iii) utilize these freely flowing energy winds to power themselves and their loads.

So we have already solved the first half of the energy crisis problem:<sup>18, 19</sup> *We can produce the necessary “EM energy wind flow” in any amount required, whenever and wherever we wish, for peanuts and with ridiculous ease. We can insure that, once initiated, the electromagnetic energy wind flows indefinitely or until we wish to shut it off.*

A tiny part of the far frontier of the scientific community is also now pushing hard into catching and using this available EM energy from the vacuum.<sup>20</sup> However, they are completely unfunded and working under extremely difficult conditions.<sup>21</sup>

In addition, there are more than a dozen appropriate processes *already available* (some are well-known in the hard literature), which can be developed to produce the new types of electrical energy systems.<sup>22</sup>

#### WHAT MUST BE DONE TECHNICALLY

We have about 2½ years to develop several different types of systems for the several required major applications—and particularly the following:

(1) Self-powering open electrical power systems extracting their electrical energy directly from the active vacuum and readily scalable in size and output,

(2) Burner systems<sup>23</sup> to replace the present “heater” elements of conventional power plants, increasing the coefficient of performance (COP)<sup>24</sup> of those altered systems to COP>1.0, and perhaps to COP = 4.0,

(3) Specialized self-powering engines to replace small combustion engines,<sup>25</sup>

(4) Self-regenerating, battery-powered systems enabling practical electric automobiles, based on the Bedini<sup>26</sup> process,

(5) Kawai COP>1.0 magnetic motors<sup>27</sup> with clamped feedback, powering themselves and their loads,

(6) Magnetic Wankel engines<sup>28</sup> with small self-powering batteries, which enable a very practical self-powering automotive engine unit for direct replacement in present automobiles,

(7) Permanent magnet motors such as the Johnson<sup>29</sup> approach using self-initiated exchange force pulses<sup>30</sup> in nonlinear magnetic materials to provide a nonconservative field, hence a self-powering unit,

(8) Iterative retroreflective EM energy flow systems which intercept and utilize significant amounts of the enormous Heaviside dark energy<sup>31</sup> which surrounds every electrical circuit but is presently ignored,

(9) Iterative phase conjugate retroreflective systems which passively recover and reorder the scattered energy dissipated from the load, and reuse the energy again and again,<sup>32</sup>

(10) Shoulders’ charge cluster devices<sup>33</sup> which yield COP>1.0 by actual measurement,

(11) Self-exciting systems using intensely scattering optically active media and iterative asymmetrical self-regauging<sup>34, 35, 36, 67,</sup>

(12) True negative resistors such as the Kron<sup>37</sup> and Chung<sup>38</sup> negative resistors, the original point-contact transistor<sup>39</sup> which can be made into a negative resistor, and the Fogal negative resistor semiconductor, and

(13) Overunity transformers using a negative resistor bypass across the secondary, reducing the back-coupling from secondary to primary and thus lowering the dissipation of energy in the primary.<sup>40</sup>

#### WHAT MUST BE DONE FOR MANAGEMENT AND ORGANIZATION

*To meet the critical 2003 “point of no return” milestone, the work must be accomplished under a declared National Emergency and a Presidential Decision Directive.*

The work must be amply funded, with authority—because of the extreme emergency—to utilize any available patented processes and devices capable of being developed and deployed in time, with accounting and compensation of the inventors and owners separately.

As an example, two of the above mentioned devices—the Kawai engine and the magnetic Wankel engine—can be quickly developed and produced en masse. However, they have been seized by the Japanese Yakuza<sup>41, 42, 43</sup> and are being held off the world market. The two devices are quite practical and can be developed and manufactured with great rapidity. As an example, two models of the Kawai engine were tested by Hitachi to exhibit COP = 1.4 and COP = 1.6 respectively. Use of these two inventions, under U.S. Government auspices, will greatly contribute to solving a significant portion of the transportation power problem, at low risk for this

part of the solution. Use of them cannot be obtained by normal civil means, due to the involvement of the Yakuza.

The *technical* part of the project to solve the energy crisis is doable in the required time—but just barely, and only if we move at utmost speed.

*Thanks to more than 20 years work on unconventional solutions to the problem, much of the required solution is already in hand, and the project can go forward at top speed from the outset*

The remaining managing and organizing problem is to marshal the necessary great new Manhattan Project as a U.S. Government project operating under highest national priority and ample funding. The Project must be a separate Agency, operating directly under the appropriate Department Secretary and reporting directly to the President (through the Secretary) and to a designated Joint Committee of the Senate and the House.

The selection of the Managers and Directors must be done with utmost care; else, they themselves will become the problem rather than the solution. We strongly stress that here even the most highly qualified managerial scientist may have to be disqualified because of his or her own personal biases and dogmatic beliefs. Leaders and scientists are required who will run with the COP>1.0 ball on a wide front.

The compelling authority to assign individual tasks to the National Laboratories and other government agencies is required, but under no circumstances can the project be placed under the control of the national laboratories themselves. Those laboratories such as Los Alamos National Laboratory, Lawrence Livermore National Laboratory, and Oak Ridge National Laboratory are far too committed to their entrenched Big Science projects and the resulting bias against electrical energy from the vacuum.

Assigning management of the project to them would be setting the foxes to mind the hen house, and would guarantee failure. Those agencies whose favored approaches are responsible for the present energy crisis, cannot be expected to direct an effective solution to it that is outside their managerial and scientific ansatz and totally against their institutional and professional biases. If they are allowed to direct the project, then implacable scientists, who adamantly oppose electrical energy from the vacuum from the getgo, will hamstring and destroy the project from its inception.

*Not only will they fiddle while Rome burns, but they will help burn it.*

*Enormous EM Energy Flow Is Easily Extracted From the Active Vacuum*

At any point and at any time, one can freely and inexpensively extract enormous EM energy flows directly from the active vacuum itself.

There is not now and there never has been a problem in readily obtaining as much electromagnetic energy flow from the vacuum as we wish. Anywhere. Anytime. For peanuts.

Every electrical power system and circuit ever built already does precisely that<sup>44-45</sup>. But almost all the vast EM energy flow that the present flawed systems extract from the vacuum is unaccounted and simply wasted. It is wasted by the conventional, seriously flawed circuits and systems designed and built by our power system scientists and engineers in accord with a terribly flawed 136-year-old set of electrodynamics concepts and foundations. Specifically, it is wasted because Lorentz discarded it a century ago.<sup>45</sup> Since then, everyone has blindly followed Lorentz's lead.

*Our electrical scientists and engineers have not yet even discovered how a circuit is powered!*

They have no valid concept of where the electrical energy flowing down the power line actually comes from. They do not model the interaction that provides it,<sup>46</sup> in their theoretical models and equations. This vast scientific “conspiracy of ignorance” is completely inexplicable, because the actual source of the EM energy powering the external circuits has been known (and rigorously proven) in particle physics for nearly half a century! However, *it has not yet even been added into the fundamental electrical theory used in designing and building power systems.*

We have a *scientific mindset problem* of epic proportions, and scientific negligence and electromagnetics dogma of epic proportions. I sometimes refer to this as an unwitting “conspiracy of ignorance”, where I use the word “ignorance” technically as meaning “unaware”. We certainly do not intend the phrase to be pejorative.

So we do not have an energy problem per se. We have an unwitting *conspiracy of scientific ignorance* problem.

Because of its bias, our electrical scientific community also strongly resists updating the 136-year-old electrodynamics foundations even though much of it is known to be seriously flawed and even incorrect<sup>47, 48</sup>. Indeed, organized science has always fiercely resisted strong innovation. As Max Planck<sup>49</sup> so eloquently put it,

“An important scientific innovation rarely makes its way by gradually winning over and converting its opponents: it rarely happens that Saul becomes Paul. What does happen is that its opponents gradually die out, and that the growing generation is familiarized with the ideas from the beginning.”

Arthur C. Clarke<sup>50</sup> expressed it succinctly for our more modern scientific community, as follows:

“If they [quantum fluctuations of vacuum] can be [tapped], the impact upon our civilization will be incalculable. Oil, coal, nuclear, hydropower, would become obsolete—and so would many of our worries about environmental pollution.” “Don’t sell your oil shares yet—but don’t be surprised if the world again witnesses the four stages of response to any new and revolutionary development: 1. It’s crazy! 2. It may be possible—so what? 3. I said it was a good idea all along. 4. I thought of it first.”

With respect to extracting and using EM energy from the vacuum, our present scientific community is mostly in Clarke’s phase 1. A few scientists are in phase 2 but surmise that “it may perhaps be the science of the next century.”

*We do not have a century remaining. We have 2<sup>1/2</sup> years.*

For nearly half a century (i) the active vacuum, (ii) the vacuum’s energetic interaction with every dipole, and (iii) the broken symmetry of the dipole<sup>51</sup> in that energetic interaction<sup>55</sup> have been known and proven in particle physics. These proven COP>1.0 vacuum energy mechanisms have not been incorporated into the electrodynamic theory used to design and build electrical power and transportation systems.<sup>52</sup> We are still waiting for the “old scientific opponents”—adamantly opposed to the very notion of electrical energy from the vacuum—to “die off and get out of the way.”

Hence our universities, the National Science Foundation, the National Academy of Science, the National Laboratories, etc. have not taken advantage of the enormous EM energy so universally available from the active vacuum, and in fact universally and copiously extracted from the vacuum by every EM system today—and wasted. Indeed, present organized science will not fund and will not tolerate research that would violate the presently decreed view of power systems and their functioning.

Hence, our present organized scientific community will strongly resist funding of a vigorous program to gather all this *proven, known physics* together and rapidly use it to change and update (modernize) the terribly flawed EM theory and the design of electrical power systems. Most scientists attempting to do this research have had to proceed on their own. They have undergone vicious and continual *ad hominem* attacks, lost research funds and tenure, been unable to get their papers published, and in fact risked being destroyed by the scientific community itself.<sup>21</sup>

The bottom line is this: *Left to sweet reason, because of the depth of its present bias the scientific community is totally incapable of reacting to the problem in time to prevent the destruction of civilization. If we wish to survive, government will have to directly force the scientific community to do the job, over careers and “dead bodies” (so to speak) if necessary.*

But first the government itself must be motivated to do so.

Only the environmental community has the clout, financial resources, and activists to motivate the government in the extremely short time in which it must be accomplished. So it would seem that the most urgent task is to educate and wake up the environmental community. It has been “had”, and it has been “had” since the beginning.

#### *Understanding What Powers Electrical Circuits*

Let us cut through the scientific errors in how electrical power systems are presently viewed: *Batteries and generators themselves do not power circuits.* They never have, and they never will. They dissipate their available internal energy<sup>53</sup> to do one thing and one thing only: forcibly separate their own internal charges to form a “source dipole.”<sup>54</sup> Once the dipole has been formed, the dipole directly extracts electromagnetic energy from the active vacuum, pouring the extracted EM energy out from the terminals of the battery or generator.

*Batteries and generators make a dipole, nothing else.* All the fuel ever burned, the nuclear fuel rods ever consumed, and chemical energy ever expended by batteries, did nothing but make dipoles. None of all that destructive activity, of itself, ever added a single watt to the power line.

Once made, *the dipole* then extracts EM energy from the seething vacuum, and pours it out down the circuit and through all surrounding space around the circuit.<sup>56</sup> A little bit of that energy flow strikes the circuit and enters it by being de-



flected (diverged) into the wires.<sup>57</sup> That tiny bit of intercepted energy flow that is diverged into the circuit, then powers the circuit (its loads and losses).<sup>58</sup>

All the rest of that huge energy flow around the circuit just roars on off into deep space and is wasted.

#### *The Dipole Extracts Enormous Energy from the Vacuum*

The outflow of EM energy extracted from the vacuum by a small dipole is enormous. It fills all space surrounding the attached external circuit (e.g., surrounding the power lines attached to a power plant generator).<sup>56</sup> In the attached circuits, the electrical charges on the surfaces of the wires are struck by the mere edge of the violent flow of EM energy passing along those surfaces. The resulting tiny “intercepted” part<sup>57</sup> of the EM energy flow is deflected into the wires, very much like placing one’s hand outside a moving automobile and diverting some of the wind into the car. The deflected energy that enters the wires is the Poynting component of the energy flow. It is *not* the entire EM energy flow by any means, but only a very, very tiny component of it.<sup>58</sup>

*Only that tiny bit of the energy flow that is actually diverged into the wires is used to power the circuit and the loads. All the rest of the enormous energy flow present and available outside the circuit is just ignored and wasted.*

A nominal 1-watt generator, e.g., is actually one whose external circuit can “catch” only one watt of its output. The generator’s actual total output—in the great flow which fills all space around the external circuit and is not intercepted and used—is something on the order of 10 trillion watts!

#### *Our Scientists and Engineers Design Dipole-Destroying Systems*

Here is the most inane thing of all. Precisely half of the small amount of energy that is actually caught by the circuit is used to destroy the dipole! That half of the intercepted energy does not power the load, nor does it power losses in the external circuit. Instead, it is used to directly scatter the dipole charges and destroy the dipole.

Our scientists and engineers have given us the ubiquitous closed current loop circuit,<sup>59</sup> *which destroys the dipole faster than it powers the load.* In short, the scientists and engineers design and build only those electrical power systems that “continuously commit suicide” by continuously destroying the source dipole that is extracting the vacuum energy and emitting it out along the circuit to power everything in the first place.

So now, we have the real picture.

*Every electrical load ever powered, and every load powered today, has been and is powered by electromagnetic energy extracted directly from the seething vacuum by the source dipole in the generator or battery.*

*However, our scientists and engineers design and build electrical power systems that only intercept and use a tiny fraction of the vast EM energy flow available. They also only design and build systems that destroy their source dipole faster than they power their loads.*

If one does not destroy the dipole once it is made, it will continue to freely extract copious EM energy flow from the vacuum, indefinitely, pouring out a stupendous flow of EM energy.

As an example, dipoles in the original matter formed in the Big Bang at the beginning of the universe have been steadily extracting EM energy from the vacuum and pouring it out for about 15 billion years.

The energy problem *is not* due to the inability to produce copious EM energy flows at will—as much as one wishes, anywhere, anytime. Every dipole already does this, including in every EM power system ever built.

The energy problem *is* due to the complete failure to (i) intercept and utilize more of the vast energy flows made available by the common dipole, and (ii) doing so without using the present inanely designed circuits. These circuits use half their collected energy to destroy the dipole that is extracting the energy flow from the vacuum in the first place!

This is part of the “conspiracy of scientific ignorance” earlier mentioned.

#### *Ignoring the Vacuum as the Source of Electrical Energy in All Circuits*

In their conventional theoretical models, our present electrical power system scientists and engineers do not even include the vacuum interaction or the dipole’s extraction of EM energy from the vacuum. They simply ignore—and do not model—what is really powering every electrical system they build.

Consequently, we reiterate that our electrical scientists have never even discovered how an EM circuit is powered—although it has been discovered and known for nearly 50 years in particle physics.

*All the hydrocarbons ever burned, all the water over all the dams ever built, all the nuclear fuel rods ever expended in all the nuclear power plants, added not a single watt to the power line.*

Instead, all that expense, effort, and pollution and destruction of the biosphere was and is necessary in order to keep adding internal energy to the generator—so that it can keep continually rebuilding its source dipole that is continually destroyed by the inane circuits that the power system scientists and engineers keep designing and building for us.

It takes as much energy input to the generator to *restore* the dipole, as it took the circuit to *destroy* the dipole. Thus all the systems our scientists and engineers design and build, require that we continually input more energy to *restore the dipole*, than the circuit *dissipates in the load*.

Our technical folks thus happily design and give us systems which can and will only exhibit  $COP < 1.0$ —thus continuing to require that we ourselves steadily provide more energy to the system to continually rebuild its dipole, than the inane masochistic system uses to power its load.

In short, we pay the power companies (and their scientists and engineers) to deliberately engage in a giant wrestling match inside their generators and *lose*.

That *is not* the way to run the railroad! One is reminded of one of the classic comments by Churchill:

“Most men occasionally stumble over the truth, but most pick themselves up and continue on as if nothing had happened.”

It seems that not very many energy system scientists and engineers have “stumbled over the truth” as to what really powers their systems, and how inanely they are really designing them.

#### *Electrical Energy Required from Hydrocarbon Burning Drives the Problem*

The heart of the present environmental pollution problem is the ever-increasing need for electrical energy obtained from burning of hydrocarbon fuels and/or nuclear power stations.

The increasing production of electrical power to fill the rising needs, increasingly pollutes the environment including the populace itself (lungs, bodies, etc.). Almost every species on earth is affected, and as a result every year some species become extinct.

Environmental pollution includes pollution of the soil, fresh and salt water, and the atmosphere by a variety of waste products. Given global warming, it also includes excess heat pollution in addition to chemical and nuclear residues.

Under present procedures, the electrical energy problem is exacerbated by decreasing available oil supplies, which are believed to have peaked this year, with a projected decline from now on.

But really, the electrical energy problem is due to the scientific community’s adamant defense and use of electrical power system models and theories that are 136 years old<sup>60</sup> in their very foundations. These models and theories are riddled with errors and non sequiturs, and seriously flawed.

*The scientific community has not even recognized the problem, much less the solution.* In fact, it does not even *intend* to recognize the problem, even though the basis for it has been known in particle physics for nearly 50 years. As Bunge<sup>61</sup> put it some decades ago:

“. . . it is not usually acknowledged that electrodynamics, both classical and quantal, are in a sad state.”

The scientific community has done little to correct that fundamental problem since Bunge made his wry statement.

Let us put it very simply: The most modern theory today is modern gauge field theory. In that theory, freedom of gauge is assumed from the getgo. Applied to electrodynamics, this means—as all electrodynamicists have assumed for the last century or longer—that the potential energy of an EM system can be freely changed at will. In other words, in theory it costs nothing at all to increase the EM energy collected in a system; this is merely “changing the voltage”, which does not require power. In other words, we can “excite” the system with excess energy (actually taken from the vacuum), at will. For free. And the best science of the day agrees with that statement.

It also follows that we can freely change the excitation energy again, at will. In short, we can dissipate that excess energy freely and at will. Without cost.

Well, this means that we are free—by the laws of nature, physics, thermodynamics, and gauge field theory—to dissipate that free excess potential energy in an external load, thus doing “free work”.

Since none of the systems our energy scientists and engineers build for us are *doing* that, it follows *a priori* that the fault lies entirely in their own system design and building. It does not lie in any prohibition by nature or the laws of physics.

*A priori*, then, the present COP<1.0 performance of our electrical power systems is a monstrosity and the direct fault of our scientists and engineers. We cannot blame the laws of nature or the laws of physics.

The present energy crisis then is due totally to that “conspiracy of ignorance” we referred to. It is maintained by the scientific community today, and it has been maintained by it for more than 100 years.

This is the real situation that the environmentalists must become aware of, if they are to see the correct path into which their energies and efforts should be directed—to solve both the energy crisis and the problem of gigantic pollution of the biosphere.

#### *Outside Intervention Must Forcibly Move Energy Science Forward*

Unless outside intervention occurs forcibly, the scientific community’s lock-up of research funds for “in the box” energy research may result in the economic collapse of the Western World in perhaps as little as 8 years.

Let us examine the gist of the problem facing us.

Suppose we launch a crash program to develop, manufacture, deploy, and employ the new “vacuum powered” systems. Once the new self-powering systems are developed and ready to roll off the production lines en masse, it will require a minimum of 5 years worldwide to sufficiently alter the “electrical energy from oil” demand curve, so that economic collapse can be averted. In turn, this means that the new systems must be ready to roll off the manufacturing lines by the end of 2003. While this is a very tight schedule, it can be done if we move rapidly.

The necessary scientific corrections along the lines indicated in this paper can be quickly applied to solve the electrical energy problem permanently and economically, given a Manhattan type project under a Presidential Decision Directive together with a Presidential declaration of a National Energy Emergency.

In a paper<sup>62</sup> to be published in Russia in July 2000, this researcher has proposed some 15 viable methods for developing new “self-powering” systems powering themselves and their loads with energy extracted from the vacuum. Several of these systems can be developed very rapidly, and can be easily mass-produced.

A second paper<sup>63</sup> will be published in the same proceedings, revealing the Bedini method for invoking a negative resistor inside a storage battery. The negative resistor freely extracts vacuum energy and adds it to both the battery-recharging function and the load powering function.

In Bedini’s negative resistor method, the ion current inside the battery is decoupled (dephased) from the electron current between the outer circuit and the external surfaces of the battery plates. This allows the battery to be charged (with increased charging energy) simultaneously as the load is powered with increased current and voltage.

At my specific request, both papers were thoroughly reviewed by qualified Russian scientists, and the premises passed successfully.

A third paper<sup>64</sup> gives the exact giant negentropy mechanism by which the dipole extracts such enormous energy from the vacuum. We will further explain that mechanism below.

#### *Conventional Approaches: Too Little, Too Late*

It appears that the Environmental Community itself has finally realized that the present scientific approaches and research are simply too little and too late. Further, the conventional approaches are largely “in the box thinking” applied to an “out of the box problem.” We leave it to others such as Loder<sup>65</sup> to succinctly summarize the shortfalls of these present solutions. Loder, e.g., particularly and incisively explains how the problem with automobiles breaks down.

In fact, no single COP>1.0 approach will be all sufficing. Several solutions, each for a different application, must be developed and deployed simultaneously.

As an example, it is possible to create certain dipolar phenomena in plasmas produced in special burners, such that the dipoles extract substantial excess EM energy from the vacuum. Output of the excess energy produces ordinary excess heat well beyond what the combustion process alone will yield. Given a Manhattan type project, the inventor of that process (with already working models and rigorous measurements) could rapidly be augmented to develop a series of replacement burners (heaters). They could be used in existing electrical power plants to heat the water to make the steam for the steam turbines turning the shafts of the generators. The entire remainder of the power system, grid, etc. could be left intact. Some

fuel would still be burned, but far less would be consumed in order to furnish the same required heat output.

*In short, a rather dramatic reduction in power plant hydrocarbon combustion could be achieved—in the present electrical power plants with minimum modification, and in the necessary timeframe—while maintaining or even increasing the electrical energy output of the power systems.* We believe the inventor would fully participate in a government-backed Manhattan type energy program where a National Emergency has been declared, given a U.S. Government guarantee that his process, equipment, and inventions will not be confiscated.<sup>66</sup>

Another process capable of quick development and enormous application is the development of point contact transistors as true negative resistors.<sup>39</sup>

Two other processes that can be developed for massive production in less than 2 years are (i) the Kawai process,<sup>27</sup> and (ii) the magnetic Wankel process.<sup>28</sup> In addition, the Johnson<sup>29</sup> process can be developed and readied for manufacture in the same timeframe, given a full-bore sophisticated laboratory team.

There are other processes<sup>67, 62–63</sup> which can also be developed rapidly, to provide major contributions in solving their parts of the present “electrical energy from hydrocarbon combustion” problem.

#### *Giant Negentropy and a Great New Symmetry Principle*

We now summarize some recent technical discoveries by the present author that bear directly upon the problem of extracting and using copious EM energy flows from the vacuum.

Any dipole has a scalar potential between its ends, as is well known. Extending earlier work by Stoney,<sup>68</sup> in 1903 Whittaker<sup>69</sup> showed that the scalar potential decomposes into—and identically is—a harmonic set of bidirectional longitudinal EM wavepairs. Each wavepair is comprised of a longitudinal EM wave (LEMW) and its phase conjugate LEMW replica. Hence, the formation of the dipole actually initiates the ongoing production of a harmonic set of such biwaves in 4-space.<sup>70</sup>

We separate the Whittaker waves into two sets: (i) the convergent phase conjugate set, in the imaginary plane, and (ii) the divergent real wave set, in 3-space. In 4-space, the 4th dimension may be taken as *-ict*. The only variable in *-ict* is *t*. Hence the phase conjugate waveset in the scalar potential’s decomposition is a set of harmonic EM waves converging upon the dipole in the time dimension, *as a time-reversed EM energy flow structure inside the structure of time*.<sup>71</sup> Or, one can just think of the waveset as converging upon the dipole in the imaginary plane<sup>72</sup>—a concept similar to the notion of “reactive power” in electrical engineering.

The divergent real EM waveset in the scalar potential’s decomposition is then a harmonic set of EM waves radiating out from the dipole in all directions at the speed of light. As can be seen, there is perfect 4-symmetry in the resulting EM energy flows, but there is broken 3-symmetry since there is no observable 3-flow EM energy input to the dipole.

Our professors have taught us that output energy flow in 3-space from a source or transducer, must be accompanied by an input energy flow in 3-space. That is not true. It must be accompanied by an input energy flow, period. That input can be an energy flow in the 4th dimension, time—or we can consider it as an inflow in the imaginary plane. The *flow of energy* must be conserved, not the *dimensions in which the flow exists*. There is no requirement by nature that the inflow of EM energy must be in the same dimension as the outflow of EM energy.

Indeed, nature prefers to do it the other way! Simply untie nature’s foot from the usually enforced extra condition of 3-space energy flow conservation. Then nature joyfully and immediately sets up a giant 4-flow conservation, ongoing. Enormous EM energy is inflowing from the imaginary plane into the source charge or dipole, and is flowing out of the source charge or dipole in 3-space, at the speed of light, and in all directions.

In other words, nature then gladly gives us as much EM energy flow as we need, indefinitely—just for paying a tiny little bit initially to “make the little dipole.” After that, we never have to pay anything again, and nature will happily keep on pouring out that 3-flow of EM energy for us. This is the giant negentropy mechanism I uncovered, performed in the simplest way imaginable: just make an ordinary little dipole.

We may interpret the giant negentropy mechanism in electrical engineering terms.<sup>73</sup> The EM energy flow in the imaginary plane is just incoming “pure reactive power” in the language of electrical engineering. The outgoing EM energy flow in the real plane (3-space) is “real power” in the same language. So the dipole is continuously receiving a steady stream of reactive power, transducing it into real power, and outputting it as a continuous outflow of real EM power.

Further, there is perfect 1:1 correlation between the convergent waveset in the imaginary plane and the divergent waveset in 3-space. This perfect correlation between the two sets of waves and their dynamics represents a *deterministic re-ordering* of a fraction of the 4-vacuum energy. This re-ordering initiated by the formation of the dipole spreads radially outward at the speed of light, continuously.

This clearly shows that (i) we can initiate reordering of a usable fraction of the vacuum's energy at any place, anytime, easily and cheaply (we need only to form a simple dipole), and (ii) the process continues indefinitely, so long as the dipole exists, without the operator inputting a single additional watt of power.

This is a very great benefit. *So long as the dipole exists, this re-ordering continues and a copious flow of observable, usable EM energy pours from the dipole in all directions at the speed of light.*

This is the full solution to the first half of the energy crisis, once and for all.

#### *Ansatz of the Major Players*

To appreciate the difficulty in implementing the solution to the energy crisis, one must be aware of the characteristics of the major communities whose dynamics and interactions determine the outcome. Accordingly, we summarize our personal assessment of the present “status” and “awareness” of the various communities involved. We do that by attempting to express the overall “ansatz” of the specific community.

#### SCIENTIFIC COMMUNITY

For the most part, the organized scientific community varies from highly resistant to openly hostile toward any mention of extracting copious EM energy from the active vacuum. The “Big Nuclear” part of the community is particularly adamant in this respect, as witness its ferocious onslaught on the fledgling and struggling cold fusion researchers—a ferocity of scientific attack seldom seen in the annals of science<sup>74–75</sup>.

The scientific community also largely suppresses<sup>76</sup> or severely badgers scientists attempting to advance electrodynamics to a more modern model, suitable to the needs of the 21st century and the desperate need for cheap, clean, nonpolluting electrical power worldwide.<sup>21</sup> The community still applies classical equilibrium thermodynamics to the electrical part of all its electrical power systems, even though every EM system is inherently a system far from equilibrium with the active vacuum environment, and a different thermodynamics applies. Only if the system is specifically so designed—e.g., so that during the dissipation of its excitation energy it enforces the Lorentz symmetrical regauging condition—will the system behave as a classical equilibrium system.

The thermodynamics of open dissipative systems is well known.<sup>77</sup> Such a system is permitted to (1) self-order, (2) self-oscillate or self-rotate, (3) output more energy than the operator inputs (the excess energy is freely received from the active environment), (4) power itself and its load simultaneously (all the energy is taken from the active environment, similar to a windmill's operation), and (5) exhibit negentropy.

Our present electrical power systems do not do these five things, even though each is an open system in violent energy exchange with the vacuum. A priori, that reveals it is the scientific model and the engineering design that are at fault.

*It is not any law of nature or principle of physics that prevents self-powering open electrical power systems. Instead, it is the scientific community and its prevailing mindset against extracting and using EM energy from the vacuum.*

#### ENVIRONMENTAL COMMUNITY

In the past, the environmental community has been overly naive with respect to physics, and particularly with respect to electrical physics. Its science advisors have come mostly from the conservative “in the box” scientific community. Hence, the community has failed to realize that COP>1.0 electrical power systems are normal and permitted by the laws of nature and the laws of physics. They have no inkling that Heaviside discovered—in the 1880's!—the enormous unaccounted EM energy pouring from the terminals of any battery or generator. They are unaware that Poynting considered only the tiny component of the energy flow that enters the circuit. They are also unaware that, completely unable to explain the astounding enormity of the EM energy flow if the nondiverged (nonintercepted) Heaviside component is accounted, Lorentz<sup>18</sup> just arbitrarily used a little procedure to *discard* that troublesome Heaviside “dark” (unaccounted) component.

Lorentz reasoned that, since the huge dark energy flow component missed the circuit entirely, it “had no physical significance.” This is like arguing that none of the wind on the ocean has any physical significance, except for that small portion of the

wind that strikes the sail of one's own sailboat. It ignores the obvious fact that whole fleets of additional sailboats can also be powered by that "physically insignificant" wind component that *misses* one's own sailboat entirely.

Nonetheless, electrodynamicists continue to use Lorentz's little discard trick, and try to call the feeble Poynting energy flow component caught by the circuit the *entire* EM energy flow connected with it. This is like arguing that the component of wind hitting the sails of one's own sailboat, is the entire great wind on the ocean.

As a result, the environmental community has failed to grasp the technical reason for the energy crisis and the increasing pollution of the biosphere. They have been deceived and manipulated into thinking that conventional organized science is giving them the very best technical advice possible on electrical power systems. The environmentalists have been and are further deceived into believing that the conventional scientific community is advocating and performing the best possible scientific studies and developments for trying to solve the energy crisis.

Of major importance, the environmental community itself has been deceived as to the exact nature of the energy flow in and around a circuit, the vastness of the unaccounted energy flow (or even that any of the energy flow is deliberately unaccounted), and the fact that this present but unaccounted EM energy flow can be intercepted and captured for use in powering loads and developing self-powering systems.

Worst of all, the environmental community has been deceived as to what powers every electrical load and EM circuit. They have been deceived into believing that burning all those hydrocarbons, using those nuclear fuel rods, building those dams and windmills, and putting out solar cell arrays are necessary and the best that can be done. In short, they have been smoothly diverted from solving the very problem—the problem of the increasing pollution and destruction of the biosphere—they are striving to rectify.

However, their continued demonstrations in the street demonstrate that many environmentalists now suspect that much of the world's continued policy of "the rich get richer and the poor get poorer" in international trade agreements are deliberately planned and implemented.<sup>78</sup> They perceive the implementation to the advantage of a favored financial class and the exploitation of the poorer laboring classes in disadvantaged nations.

#### ELECTRICAL POWER COMMUNITY

The electrical power community:

(1) ubiquitously uses equilibrium thermodynamics, believing that  $COP > 1.0$  is perpetual motion nonsense and against the laws of physics,

(2) has no notion that the energy flowing down their power lines and filling all space around them, is extracted directly from the active vacuum by the source dipole in the generator,

(3) erroneously believes that the hydrocarbons they burn, or the water through the hydroturbines at the dam, or the nuclear fuel rods they consume, actually add the power to the transmission lines,

(4) uses half of the tiny component of energy caught by the power lines, to destroy the source dipoles in their generators, thus requiring ever more shaft input energy via powering a steam turbine, hydroturbine, etc.,

(5) believes that energy can be "used" only once, when in fact it can be used and re-used repeatedly since it cannot be created or destroyed,

(6) allows only a single pass of the EM energy flow down the power lines, so that only one tiny interception of energy occurs from the energy flow and the rest (most) of the energy flow is wasted,

(7) believes that the electrical energy problem translates into more hydrocarbon combustion or nuclear fuel rod consumption rather than a totally different way of doing business, and

(8) believes that the theory they apply is correct, when in fact it is so seriously flawed as to be inane, *and has been inane for a century*.

Industries also acquire their own hidden agendas, when serious threats to the industries arise. As an example, a potentially serious problem arose some decades ago when it became apparent that EM radiation from power lines might detrimentally affect people or at least some people. To put it gently, a great deal of fuss and fury resulted, and a great deal of money was and is spent by the power companies (or through organizations and foundations funded by them) in EM bioeffects research. Not too surprisingly, just about the entire output of this industry-funded research "finds" that there is no problem with powerline radiation.<sup>79</sup> Those scientists such as Robert Becker<sup>80-81</sup> who advocate or show otherwise, usually wind up having all

their funds cutoff, hounded from their jobs, and—in the case of Becker—forced to retire early.

It is no different in the electrical energy science field.<sup>21</sup>

#### STORAGE BATTERY COMPANIES

Battery companies are primarily of much the same outlook and ansatz as are the power companies. They have gone to pulse charging of batteries and improved battery chemistry and materials.<sup>82</sup> They have no notion that batteries do not power circuits, but only make source dipoles—and it is the source dipole that then extracts EM energy from the vacuum and pours it out into the external circuit.

Consequently, they erroneously believe that chemical energy in the battery is expended *in order to provide power to the external circuit*. Instead, it is expended only to continuously remake the source dipole, which the closed current loop circuit fiendishly keeps destroying faster than the load is powered.

They also have not investigated deliberately dephasing and decoupling the major ion current within the battery and between the plates, from the electron current between the outside of the plates and the external circuit. Consequently they have no concept of permissible Maxwellian COP>1.0 battery-powered systems. Instead, battery companies, scientists, and engineers still believe—along with the power companies and most electrodynamicists, and the environmental community—that applying the Lorentz symmetrical regauging to the Heaviside–Maxwell equations retains all the Maxwellian systems. It does not. Instead, it arbitrarily discards all Maxwellian systems which are permitted by the laws of nature and the laws of physics to produce COP>1.0!

#### UNIVERSITY COMMUNITY

The University community mostly supports the prevailing EM view. It also suffers from the rise of common “greed” in the universities themselves. The professor now must attract external funding (for his research, and for his graduate students—and especially for the lucrative “overhead” part of the funding which goes to the university itself). The research funds available for “bidding” via submitting proposals, are already cut into “packages” where the type of research to be accomplished in each package is rigorously specified and controlled. Research on COP>1.0 systems is strictly excluded. Dramatic revision of electrodynamics is excluded.

Unless the professor successfully bids and obtains packages and their accompanying funding, he is essentially ostracized and soon discharged or just “parked” by the wayside. Also, if he tries to “go out of the box” in his papers submitted for publication, his peer reviewers will annihilate him and his papers will not be published. Shortly he will effectively be blacklisted and it will be very difficult for him to have his submitted papers honestly reviewed, much less published. Again, that means no tenure, no security, and eventual release or “dead-end parking” by the university.

When one looks at the “innovative” packages so highly touted, they either (1) are research focused upon some approved thing such as hot fusion—which has spent billions and has yet to produce a single watt on the power line, and cannot do so in any reasonable time before the collapse of the Western economy—or (2) use clever buzzwords for things which are actually “more of the same” and “in the box thinking” with just some new words or twists thrown in for spin control.

Meanwhile, all this makes for a self-policing system, which rewards conservatism—conservative publications, conservative research, conservative thinking, conservative teaching, etc. In short, it selects and approves electrical power system research that is “too little, too late” to solve the world energy crisis in time, and ruthlessly rejects all the rest. It also makes for a self-policing system which roots out and destroys (or parks on the sidelines) those professors, graduate students, and post-docs who—given a chance to be highly innovative and “out of the box” researchers—might upset the status quo.

In short, the scientific community is itself the greatest arch foe of high innovation, just as Planck indicated. The university generally typifies and reflects that overall attitude because its outside research funds are controlled and managed by the upper echelons of the organized Big Science community and the governmental community.

#### GOVERNMENT COMMUNITY—TECHNICAL

The technical part of the U.S. Government research community is drawn from the universities, private industry, etc. It mostly reflects an even more conservative group than the universities. Again, papers published and funding are the major requirements, within given and largely accepted scientific constraints. Further, the managerial government scientists must compete for funding, annual budgets, etc.

and have their own “channel” constraints from on high. At the top levels (such as NSF and NAS), cross-fertilization by the aims and perceptions of the conservative scientific community leaders is achieved.

Hence the government technical community is largely constrained in two fashions: (1) by its own forced competition for funds, facilities, positions, programs, etc., and (2) by its strong cross-fertilization from the top scientific personnel in NSF, NAC, etc. Individual scientists also face the need to publish or perish, and so are further constrained by the reviewers etc. of the journals.

Most managers within the government scientific community are striving to scamper up the managerial ladder, much as managers elsewhere. One’s power and prestige rises as one’s position level rises—and particularly as the part of the government’s research budget rises that one controls. There is a fine tightrope to walk. As one gains control of more government budget for research, one becomes a powerful influence on the large research corporations which will submit very complex and extensive proposals for the funds.

A sort of “common understanding” thus arises between industry leaders, higher government research leaders and managers, etc. This can be so profound that the practical result is almost a sort of “collusion by common understanding” between the government and industrial complexes and a fusion into one consortium—essentially the “military-industrial complex” which President Eisenhower warned Americans against.

The result is that the government managers in their Request for Quotations (RFQs) use words such as “out of the box” and “highly innovative.” However, they rarely will fund such proposals because they simply cannot obtain approval for such budgets and programs from “higher up the chain.” As witnessed by the ultrawideband (UWB) radar controversy, the *government* technical community is even more resistant to innovation and change than is the *civilian* technical community.

As an example, the early UWB radar pioneers (Harmuth, Barrett, etc.) were attacked by entrenched government scientists and government scientific organizations with a viciousness rarely seen in the annals of government science. The objection raised was that sinusoidal EM waves could not do such things—even though the UWB radar used *nonsinusoidal* EM waves. Further, small UWB radar sets were commercially available and used to detect voids in concrete structures, the ground, etc. The *real* reasons for the violent attacks were the prestige and power of the Stealth community at the time—and because UWB radar had the implication of tracking Stealth vehicles readily.

Interestingly, the arch foes of UWB at the time, today would have us believe they are “staunch experts” in the UWB field. To understand their remarkable metamorphosis, one need only recall Arthur C. Clarke’s words, quoted earlier.

In the COP>1.0 EM energy field, we are still rather much at the stage where the UWB researchers started. We are still in the “violent attack, personal insults, character assassination, slander, libel, etc.” stage. Sadly, such *ad hominem* savagery is by scientists who themselves have no notion of how electromagnetic circuits are actually powered, and who—like ostriches—still have their heads buried in the sand back there in the 1880’s when Lorentz discarded the enormous Heaviside energy flow component.

#### GOVERNMENT COMMUNITY—NONTECHNICAL

Here we have a rather mixed situation. The nontechnical person—e.g., a Senator or a Congressperson—is operating under a distinct disadvantage. In taking the stance that much better electrical power systems can readily be achieved, he or she is, in fact, opposing almost the entire set of university, government technical, university, power company, battery company, and organized science communities. Further, in most cases his technical advisors are themselves from one or the other of those communities, and likely to go back into that community or those communities when the Senator or Congressperson leaves office, or even before. So the Congress and the nontechnical government community at large operate at a great disadvantage.

As an example, admittedly there *are* some very misguided unorthodox energy system inventors and scientists out there, who in the guise of furthering COP>1.0 systems actually contribute to the problem rather than to the solution. A few do not even realize that they cannot properly measure a “spiky” output with an RMS meter! Some are also more interested in selling “dealerships” and “stock” than in furthering the science of COP>1.0 systems. Few have submitted their purported COP>1 devices to rigorous testing by an independent, Government-certified test laboratory.<sup>83</sup>



This “noise” seriously dilutes the unconventional scientific community’s legitimate efforts in COP>1.0 systems. By playing up such “dilution” and accenting “the crazies,” the orthodox scientific community often convinces government nontechnical managers and personnel that the unorthodox scientific COP>1.0 community is comprised only of lunatics, charlatans, stock-scam artists and misguided crank inventors.

Such, of course, is not the case. A goodly number of reputable, skilled scientists are seriously struggling with the problems of developing COP>1.0 EM power systems and devices. A few are also struggling to develop an adequate theory of such systems. Progress is slowly being made and has been made, in spite of the harassment.<sup>84</sup>

The independent assessments that Congress once enjoyed with the OTA are no more because the OTA was abolished. Now the committees, subcommittees, and individual Congresspersons and Senators are largely on their own, with their own staffs and their own technical advisors.

That said, nonetheless it can be seen by savvy Senators and Congresspersons that the U.S. Ship of State is headed for a great economic bust, and probably the greatest one of all time.

The Government *Nontechnical* community (the Senate and the Congress, in particular) is in far better shape than the Government *Technical* community, to appreciate the world implications of the pending economic disaster. I am hopeful that both the environmentalists and the Government Nontechnical community will rapidly unite in a common goal to get this vacuum energy program launched, under a National Emergency declaration. If so, then they can solve the energy crisis and the pending economic crisis, in fairly short order, and permanently.

#### CONCLUSION

There is an even more ominous specter looming behind the shadow of the coming great economic collapse. When national economies get strained to the breaking point—with some of them failing, etc. worldwide as the price of oil escalates—the conflicts among nations will increase in number and grow in intensity. About a year or so ahead of the “Great Collapse” of the world economies, the intensity and desperation of the resulting national conflicts will have increased to the breaking point.

Some 25 Nations already have weapons of mass destruction (WMD)—including nuclear warheads; missile, aircraft, boat, and terrorist delivery systems; biological warfare weaponry; and other advanced weapons<sup>9–10, etc.</sup><sup>85–86</sup>.

Any knowledgeable person knows that hostile terrorist agents are already onsite here in the United States,<sup>87</sup> and some will have smuggled in their WMDs. It is not too difficult to surmise that some of those missing Russian “suitcase nukes” probably wound up *right here in the United States, hidden in our population centers*.<sup>88</sup> Or that some of Saddam Hussein’s large stock of anthrax has been spirited into the United States as well. As is well known, the threat from weapons of mass destruction is now officially recognized as the greatest strategic threat facing the United States. It is not a matter of *if* the WMD weapons will be unleashed, but *when*.

If one transposes that recognized escalating WMD threat onto the escalating economic pressures worldwide, then another factor comes into play—the dark side of the Mutual Assured Destruction (MAD) concept. We have opted (at least to date) not to defend our populace. The U.S. Government has deliberately placed U.S. population centers in a defenseless situation so that their destruction is “assured” once the WMD balloon really goes up.

The insanity of the MAD concept is revealed when war preparations by many nations start to be perceived—as they will be, when the conflicts intensify sufficiently and the looming economic collapse tightens the cinch on the nations of the world.

*Without any protection of its populace, a defending Nation has to fire on perception of nuclear preparations by its adversaries, if that Nation is to have even the slightest chance of surviving.*

At about that 2007 date when a nation sees its adversaries preparing WMD and nuclear assets for launch or use in ongoing intense conflicts, at some point that nation must pre-empt and fire massively, or accept its own “assured destruction.”

*The only question in MAD is whether the assured destruction shall be mutual or solitary.*

So one or more nations will fire, immediately moving all the rest into the “fire on perception” mode. Very rapidly, the situation then escalates to the all-out world-wide exchange so long dreaded. This massive exchange means the destruction of civilization itself, and probably much of the entire biosphere for decades or centuries. Such escalation from one or more initial nuclear firings has been shown for decades

by all the old strategic nuclear studies. It is common knowledge to strategic analysts unless one engages in wishful thinking.

Eerily, this very threat now looms in our not too distant future, due in large part to the increasing and unbearable stresses that escalating oil prices will elicit.

So about 7 years or so from now, we will enter the period of the threat of the Final Armageddon, unless we do something very, very quickly *now*, to totally and permanently solve the present “electrical energy from oil” crisis.

This is really why we must have a National Emergency proclamation, and a Manhattan Project. Mass manufacturing, deployment, and employment of replacement electrical power systems must begin in earnest in early 2004.

In my estimate, the point of no return for developing the self-powering replacement systems is about the end of 2003. If by early 2004 we do not have multiple types of vacuum-energy powered systems rolling off the assembly lines en masse, then we shall overshoot the point of no return. In that case, it matters not whether the systems then become available or not. They will then be too late to prevent the great Armageddon and the destruction of civilization.

Personally, the present author regards the increasing energy crisis as the greatest strategic threat to the United States in its entire history. I will do anything within my power to help prevent what I perceive to be the looming economic collapse of the Western world, preceded or accompanied by a sudden, explosive, all-out and continuing exchange of the WMD arsenals of most of the world.

*We can still meet this early 2004 production deadline.* It is difficult, but it is definitely a doable at this time.

*We must do it, and we must do it now.* Else the technology for electrical energy from the vacuum will also be “too little, too late.” In that case, not only the world economy, but civilization itself, will likely be destroyed—not 100 years from now, not 50 years from now, but in less than one decade from now.

*In the name of all humanity, let us begin!* Else by the time this first decade of the new millennium ends, much of humanity may not remain to see the second decade.

#### REFERENCES AND NOTES

1. And of course it is said to be accidental that all the manipulative measures and profit-taking happen to coincide with the large increase in demand in the United States during the summer vacation and tourist months.

2. E.g., see F. Gregory Gause III, “Saudi Arabia Over a Barrel,” *Foreign Affairs*, 79(3), May/June 2000, p. 80–94. Quoting, p. 82: “Saudi oil policy is now driven primarily by the immediate revenue needs of a government struggling to maintain a welfare state designed in the 1970s—when money seemed limitless and the population was small—for a society with one of the world’s fastest-growing populations.” Our comment is that the financial disarray of the Saudis is seen by Gause as a need to get Saudi Arabia into the World Trade Organization—in other words, into the clutches of globalization. For a resounding exposé of the WTO, see Lori Wallach and Michelle Sforza, *Whose Trade Organization? Corporate Globalization and the Erosion of Democracy*, published by Public Citizen Foundation and available by order from the web at <http://www.globaltradewatch.org>. Wallach and Sforza reveal and document the machinations of the World Trade Organization as an instrument of globalization and usurpation of national rights. The WTO is only one of many organizations prepared by the High Cabal (Winston Churchill’s term) to establish the return for much of the world to a version of the old feudal capitalism where national governments posed no checks and balances and workers had no rights or benefits.

3. NAFTA stands for North American Free Trade Agreement, passed by Congress in 1993, creating a trade and investment region consisting of Canada, the United States, and Mexico. GATT stands for General Agreement on Tariffs and Trade (Uruguay Round) in 1994, which created the World Trade Organization (WTO). Other such agreements set in place to initiate world globalization financial control over nations include or have included MAI (Multilateral Agreement on Investment) and OECD (Organization for Economic Co-operation and Development) in which many of the “secret” agreements are prepared and then scurried through passage by “fast track” means where the Congress allows the President to negotiate trade agreements that are then voted on by the Congress without amendment. Quoting Moisés Naim, “Lori’s War,” *Foreign Policy*, Vol. 118, Spring 2000, p. 35, “. . . fast track is the legislative legerdemain under which Congress allows the President to negotiate trade agreements that are then voted on without amendments. Without it, the White House has no guarantee that lawmakers will not seek to change the terms of trade agreements reached after lengthy trade talks.” Our comment is that there should be no such guarantee to the White House, since the Congress consists of our

duly elected representatives—elected precisely for the purpose of representing the U.S. public rather than the Administration. The “fast track” ploy is one way of bypassing full congressional discussion, examination, etc. so that the desired globalization control measures can be “sneaked through” without a rigorous examination of their provisions. In this way, national authority and constitutional provisions can gradually be undermined by a continuing series of such sneak actions.

4. According to the International Labour Organization, some 250 million boys and girls between the ages of five and 14 are exploited in hazardous work conditions. Most of these children live in the developing world—although in industrialized countries such as the United States, hundreds of thousands of underage boys and girls are at work in sweatshops, farm fields, brothels, and on the street. E.g., see Sandy Hobbs, Michael Lavalette, and Jim McKechnie, *Child Labor*, ABC-CLIO, Inc., 1999. For a poignant visual and verbal tour through the problem, see Russell Freedman and Lewis Hine, *Kids at Work*: Lewis Hine and the Crusade Against Child Labor, Houghton Mifflin, Aug. 1994. The United Nations also has several publications on the problem and its extent.

5. As one example, the Russian mafia, together with the GRU and KGB under its new name, are the dominant factors in Russia, Russian business, and the Russian side of relations between the United States and Russia. See particularly Stanislav Lunev and Ira Winkler, *Through the Eyes of the Enemy: Russia's Highest Ranking Military Defector Reveals Why Russia Is More Dangerous Than Ever*, Regnery, Washington, DC, 1998. Quoting p. 12: “When the Soviet Union collapsed and its industries were privatized, there was only one group within Russia with the money to buy the new industries, and that was the Russian mafia. But the mafia did more than buy the industries—it bought the government.” Quoting p. 13: “The cold war is not over; the new cold war is between the Russian mafia and the United States.” Quoting p. 14: “The Soviet Union did not collapse because of ‘reform-minded leaders’ or because of the Reagan Administration’s brilliantly aggressive strategy (though that strategy played a part). The truth is that the Russian mafia caused the collapse. Soviet ‘reform’ was nothing more than a criminal revolution.”

6. As another example, the Japanese Yakuza has penetrated most large Japanese corporations, including Japanese banking and to include the national Japanese bank. E.g., see Michael Hirsh and Hideko Takayama, “Big Bang or Bust?”, *Newsweek*, Sept. 1, 1997, p. 44–45. Some \$300 billion or more were extracted by the Yakuza from the Japanese taxpayers in a great land scandal. Japan’s banks loaned billions to Yakuza-affiliated real-estate speculators, and the Yakuza would not repay the funds. The banks were literally too terrified to collect on the \$300–600 billion in bad debt that ensnared the banking system. E.g., when Sumitomo Bank got a little aggressive in collecting loans in Nagoya, its branch manager was killed. For a summary of this scandal, see Brian Bremner, “How the Mob burned the Banks: The Yakuza is at the Center of the \$350 Billion Bad-loan Scandal,” *Business Week*, Jan. 29, 1996, p. 42–43, 46–47. The Japanese government—i.e., the taxpayers—had to absorb this enormous loss.

The Yakuza have achieved the power and status of a hostile nation, operating within United States-Japanese corporate relations, within other nations’ relations with Japan, and within the oriental communities of foreign states. Great influence upon the ability or inability of the U.S. Government to continue its deficit financing now rests in the hands of the Yakuza. Effectively, the Yakuza can trigger a U.S. stock market crash at will, by simply shutting off all further Japanese purchase of U.S. Government deficit financing bonds.

The Yakuza regard themselves as the last Samurai, still follow the old Bushido concept, and are intensely hostile to the United States for the humiliating defeat of Japan in WW II and for dropping the atomic bomb on Japan. At the critical time in the coming economic crisis, cessation of Japanese purchase of U.S. Government bonds can and will initiate the financial *coup de grace* which generates the final and sudden collapse of the U.S. economy, dragging down other economies with it. It appears that the Yakuza tested the response of the U.S. stock market to this tactic on two occasions, by simply slowing the rate of Japanese purchases of U.S. Government bonds. The immediate drops in the stock market on both occasions showed the efficacy of this financial weapon, whenever the Yakuza wish to employ it.

In the United States, the Yakuza constitute an important and growing hostile terrorist group, an intense subculture increasing in numbers, and a group biding its time prior to engaging in mass terrorism strikes. Together with the Aum Shinrikyo, in 1990 the Yakuza leased the operational use of clandestine strategic longitudinal EM wave interferometer weapons in Russia. They now possess some of the most powerful strategic weapons on earth (see notes 9 and 10, below).

7. The recent historic meetings of North and South Korean leaders, with proclamations of cooperation etc., are a healthy sign for the better. With the former im-

placable North Korean dictator now dead, the new and younger leader may have less hostile outlook. However, progress can be made only very slowly, since the Communist apparatus is still in power in the armed forces and the nation. Only as more of the old die-hard Communist leaders die off, will real progress start to be made in materially lessening the threat posed by North Korea. That is a process requiring a generation, but at least a start has been made. For our thesis, that progress is likely to be sufficiently slow that, while it damps the stress curves a little, it has no appreciable effect on the overall thesis of the eruption within the decade of a great conflagration involving weapons of mass destruction.

8. Particularly see Lunev and Winkler, *ibid.*, 1998 for the fact that Spetznaiz assassination and terror teams are already deployed onsite in the United States, as are their WMD weapon caches to include nuclear weapons. A number of nations of the world have secretly deployed nuclear and biological weapons throughout the interior of their perceived enemy nations, often using diplomatic pouch privilege to bring them directly into the targeted nation. It is called “dead man fusing.” The notion was an extension of the MAD concept: with weapons and teams secreted throughout a targeted nation, then the potent threat that, even if one’s own nation is destroyed, one can still destroy the foe who did it, supposedly acts as a deterrent.

9. Also involved, there are clandestine weapons of far greater power than nuclear weapons, but most of that subject is beyond the scope of this presentation. For some time we have informed the U.S. Government of these developments, the evidence, the events, etc. An example—current at its time of preparation—is T. E. Bearden, *Energetics: Extensions to Physics and Advanced Technology for Medical and Military Applications*, CTEC Proprietary, May 1, 1998, 200+ page inclosure to CTEC Letter, “Saving the Lives of mass BW Casualties from Terrorist BW Strikes on U.S. Population Centers,” to Major General Thomas H. Neary, Director of Nuclear and Counterproliferation, Office of the Deputy Chief of Staff, Air and Space Operations, HQ USAF, May 4, 1998. Copies of a similar presentation were furnished the DoD, Senator Shelby as head of the Senate’s Intelligence subcommittee, and Congressman Weldon as head of the House’s Intelligence subcommittee efforts, as well as other U.S. Government agencies and high ranking officials.

10. The earlier clandestine asymmetrical strategic weapons were developed by the former USSR under rigid KGB and GRU control. The first of these weapons were longitudinal EM wave interferometers; see Lunev and Winkler, *ibid.* 1998, p. 30: “Other instruments of destruction the Russians have had success with are seismic weapons. Spitac and other small towns in the Transcaucasus Mountains were almost destroyed during a seismic weapons test that set off an earthquake. This would have obvious applications on America’s west coast and other areas of the world prone to earthquakes.”

These are also the weapons obliquely referred to by Defense Secretary Cohen in this statement: “Others [terrorists] are engaging even in an eco-type of terrorism whereby they can alter the climate, set off earthquakes, volcanoes remotely through the use of electromagnetic waves . . . So there are plenty of ingenious minds out there that are at work finding ways in which they can wreak terror upon other nations . . . It’s real, and that’s the reason why we have to intensify our [counterterrorism] efforts.” Secretary of Defense William Cohen at an April 1997 counterterrorism conference sponsored by former Senator Sam Nunn. Quoted from DoD News Briefing, Secretary of Defense William S. Cohen, Q&A at the *Conference on Terrorism, Weapons of Mass Destruction, and U.S. Strategy*, University of Georgia, Athens, Apr. 28, 1997. The present author has been briefing these weapons to DoD and other government agencies for many years. Most major weapons laboratories in various nations—including China—have now discovered longitudinal EM waves and either have such weapons or are furiously developing them. As an example of a test by a giant strategic longitudinal EM wave interferometer, see Daniel A. Walker, Charles S. McCreery, and Fermin J. Oliveira, “Kaitoku Seamount and the Mystery Cloud of 9 April 1984,” *Science*, Vol. 227, Feb. 8, 1985, p. 607–611; Daniel L. McKenna and Daniel Walker, “Mystery Cloud: Additional Observations,” *Science*, Vol. 234, Oct. 24, 1986, p. 412–413. This was a test in two modes: (a) in a cold explosion mode above the surface of the sea, creating a sudden low pressure zone above the water and accounting for the suction of water from the ocean to form the cloud, and (b) formation of a glowing spherical shell of light in the top of the cloud, and expanding that shell to some 400 miles diameter. The cold explosion can destroy a naval task force at sea or an armored element on the ground, as an example, or take out the personnel in fixed installations and fortified positions. The intense shell of EM energy duds the electronics of any vehicle (aircraft, missile, satellite) passing through it, by inducing an extremely sharp pulse of electromagnetic energy arising inside the electronics, from local spacetime itself. Hundreds of tests of these weapons have been observed.

The great advantage of using longitudinal EM waves is that they readily pass right through intervening mass such as the ocean or the earth, with little attenuation. Hence an underwater nuclear submarine can be destroyed deep beneath the ocean—as witnessed by precisely that test of the first deployed Russian LW weapon to kill the U.S.S. Thresher in April 1963 off the East Coast of the United States. The totally anomalous jamming signatures on the Thresher's surface companion, the U.S.S. Skylark, positively reveal the nature of the weapon employed. Kill of the Arrow DC-8 in Gander, Newfoundland was by one of these weapons, with abundant decisive signatures. The present author published a photograph of the strike of the weapon 2 weeks earlier, offset from a night shuttle launch in Cape Canaveral, Florida. This was the same weapon, being used for crew training, which destroyed the Arrow some 2 week later. The TWA-800 crash off the East Coast of the United States was also such a shoot-down, as have been numerous others over the years, documented by the present author. At least seven nations now possess such longitudinal EM wave interferometer weapons. Others are working furiously to develop them. Also, even more powerful weapons of novel kind have been developed and deployed by three nations—neither of which is the United States.

11. Proceeding conventionally, it will be 50 years before the organized scientific community will permit these emerging solutions to actually be developed and produced. This is senseless; as the Manhattan Project in WW II showed, a newly emerging technology can go to production in 4 years. Given only that neutron fission of the proper uranium isotope produced more neutrons than were input, the Manhattan Project developed operational atomic bombs of two major types in 4 years. An appreciable number of other “waiting areas for such development” exists in science in the literature. However, they are not usually pushed forward into development for decades due to the continuing resistance of the scientific community to all innovations which threaten the favored projects (such as hot fusion) and favored theories. Any “scientist in the trenches” is well aware that the progress of science is by means of a continuing massive cat and dog fight, not at all by sweet scientific reason and logic.

12. A perhaps excessive harsh characterization of these “in the box” efforts is that they represent “psychological displacement activities” for the scientific community, the government decisionmakers, and perhaps even a part of the environmental community. At best these programs represent “Look at all the good things we are doing!”. They must further be assessed with the view that “Look at what they will not do, and what the results of expending all our efforts on them will be: catastrophic economic collapse in a decade or less.”

13. We strongly point out that Maxwell's equations are purely hydrodynamic equations. There is thus a 100 percent correspondence to hydrodynamics and electromagnetic power systems. Anything that can be done mechanically, or hydrodynamically with fluid flow, can be done with electromagnetic field energy flow, *a priori*. It is thus a serious fault of the scientific community in proclaiming that electrical power systems with  $COP > 1.0$  are prohibited, because closed systems cannot exhibit  $COP > 1.0$ . All such arguments are evanescent, since all they state is that an open EM system far from thermodynamic equilibrium with the active vacuum is what is required. But the classical electrodynamics (136 years old) used to design and build electrical power systems, does not even model the energy exchange between active vacuum and the system. To put it mildly, this is a completely inexplicable aberration of the scientific mindset, and it has been such for over a century.

14. Open EM systems far from thermodynamic equilibrium with their electrically active vacuum environment are indeed permitted by the Maxwell-Heaviside equations, prior to the arbitrary symmetrical re-gauging of the equations to yield simpler equations more mathematically amenable (done by Lorenz in 1867 and later by H.A. Lorentz). The Lorentz condition requires that the system be symmetrical in its discharge of its free excitation energy. The present closed current loop circuit ubiquitously used in power systems is designed specifically such that the system itself enforces the Lorentz symmetrical discharge of its excitation energy. Thus one-half of the energy is discharged in the external losses and load, while one-half is discharged to destroy the source dipole actually extracting the EM energy from the active vacuum. Such design guarantees a system which destroys its intake of free electrical energy from the vacuum faster than it can use part of that energy to power the load. I.e., it guarantees suicidal systems which can only exhibit  $COP < 1.0$ . Every electrical system ever built has been and is powered by electrical energy extracted directly from the seething vacuum, as we explain in the present paper.

15. Such open systems far from thermodynamic equilibrium in the active vacuum exchange, rigorously are permitted to exhibit  $COP > 1.0$  and power themselves and their loads simultaneously. By building only that subset of Maxwellian systems that forces Lorentz symmetrical re-gauging during discharge of the system's excitation en-

ergy, our scientists and engineers have in fact simply discarded all those Maxwellian systems not in equilibrium with the vacuum during their excitation discharge. In short, they simply do not build any such systems, or even design such. The scientific and engineering communities themselves have directly produced and maintained the present horrible energy crisis and pollution of the biosphere.

16. Ludvig Valentin Lorenz, “On the identity of the vibrations of light with electrical currents,” *Philosophical Magazine*, Vol. 34, 1867, p. 287–301. In this paper Lorenz gave essentially what today is called the “Lorentz symmetrical regauging”. Not much attention was paid to the earlier Lorenz work. Later, H.A. Lorentz introduced the symmetrical regauging of the Maxwell–Heaviside equations, in its present modern form. Lorentz’s influence was so great that symmetrical regauging—which reduced the theory to a subset and discarded all Maxwell–Heaviside systems of COP>1.0 and capable of powering themselves and a load simultaneously—was adopted and utilized. It is still utilized ubiquitously; e.g., see

17. Lorentz symmetrical regauging is still utilized ubiquitously, so that no self-powering systems are designed and developed by our energy scientists and engineers. E.g., see J. D. Jackson, *Classical Electrodynamics*, Second Edition, Wiley, New York, 1975, p. 219–221; 811–812. In symmetrically regauging the Heaviside–Maxwell equations, electrodynamicists assume that the potential energy of a system can be freely changed at will (i.e., that the system can be *asymmetrically* regauged at will). They do it twice in succession, but carefully select two such “paired simultaneous asymmetrical regaugings” such that the two new free force fields that emerge are equal and opposite and there is thus no net force which can be used to dissipate the free excess system energy from regauging and perform work in a load. In short, they retain only those Maxwellian systems that foolishly oppose and strangle their own ability to freely discharge and use the free energy they first acquire (from the vacuum, by the first asymmetrical regauging). Thereby the energy scientists arbitrarily discard all those Maxwellian systems which net asymmetrically regauge by changing their own potential energy and also producing a net non-zero force that can be used to discharge the excess free energy in a load without reservation. Net asymmetrically regauged systems are open dissipative EM systems, freely receiving energy from their active external environment and thus permitted to dissipate the excess regauging energy in loads because they do not strangle that latter ability. Hence the performance of the *arbitrarily-excluded* Maxwellian systems is not confined to classical thermodynamics, but is described by the thermodynamics of an open dissipative system. Such systems can (i) self-organize, (ii) self-oscillate, (iii) output more energy than the operator himself inputs (the excess is freely received from the external active environment) (iv) “power” its own losses and an external load simultaneously (all the energy to operate the system and the load is received freely from the external active environment), and (v) exhibit negentropy.

18. We can now show that enormous EM energy flow can be easily and cheaply initiated from the active vacuum, anywhere, at any time. The basis for this was in fact discovered by Heaviside in the 1880’s. Lorentz knew of this huge energy flow component but discarded it arbitrarily, apparently to avoid being attacked and accused of being a perpetual motion advocate. See H.A. Lorentz, *Vorlesungen über Theoretische Physik an der Universität Leiden*, Vol. V, *Die Maxwellsche Theorie (1900–1902)*, Akademische Verlagsgesellschaft M.B.H., Leipzig, 1931, “Die Energie im elektromagnetischen Feld,” p. 179–186. Figure 25 on p. 185 shows the Lorentz concept of integrating the Poynting vector around a closed cylindrical surface surrounding a volumetric element. This is the procedure which arbitrarily selects only a small component of the energy flow associated with a circuit—specifically, the small Poynting component striking the surface charges and being diverged into the circuit to power it—and then treats that tiny component as the “entire” Poynting energy flow.

19. The mathematical “trick” used by Lorentz to get rid of this easily and universally evoked giant negentropy, is still employed by electrical scientists and engineers without realizing what is actually being discarded. For a full explanation, see T.E. Bearden, “Giant Negentropy from the Common Dipole,” *Proc. IC-2000*, St. Petersburg, Russia, July 2000 (in press). A series of excellent papers by the Alpha Foundation’s Institute for Advanced Study (AIAS) have also been published, approved for publication, or submitted for consideration, in leading journals. An example is M.W. Evans, T.E. Bearden *et al.*, “Classical Electrodynamics without the Lorentz Condition: Extracting Energy from the Vacuum,” *Physica Scripta*, Vol. 61, 2000, p. 513–517. A most formidable new AIAS paper, “Electromagnetic Energy from Curved Spacetime,” has been submitted to *Optik* and is in the referee process. Two related paper giving a very solid basis for vacuum energy are M.W. Evans *et al.*, “The Most General Form of Electrodynamics,” and “Energy Inherent in the Pure Gauge Vacuum,” both submitted to *Physica Scripta* and in the referee process. The theoretical

basis for extracting copious EM energy from the vacuum is now unequivocal and either has been published or is rapidly being published in leading journals.

20. For example, see Myron W. Evans *et al.*, AIAS group paper by 15 authors, "Classical Electrodynamics Without the Lorentz Condition: Extracting Energy from the Vacuum," 2000, *ibid.*; "Runaway Solutions of the Lehnert Equations: The Possibility of Extracting Energy from the Vacuum," *Optik*, 2000 (in press);—"Vacuum Energy Flow and Poynting Theorem from Topology and Gauge Theory," submitted to *Physica Scripta*;—"Energy Inherent in the Pure Gauge Vacuum," submitted to *Physica Scripta*;—"The Most General Form of Electrodynamics," submitted to *Physica Scripta*;—"The Aharonov-Bohm Effect as the Basis of Electromagnetic Energy Inherent in the Vacuum," submitted to *Optik*;—"Electromagnetic Energy from Curved Spacetime," submitted to *Optik*.

21. As an example: The most critical scientist in the Western world, working on the "energy from the vacuum" approach, is Dr. Myron Evans, Founder and Director of the Alpha Foundation's Institute for Advanced Study (AIAS). Dr. Evans was hounded from his professorial position, has had his life threatened, has been without salary for several years, and fled to the United States for his very life. He has some 600 papers in the hard literature, and is presently producing—in accord with Dr. Mendel Sachs' epochal union of general relativity and electrodynamics—the world's first engineerable unified field theory, and an advanced electrodynamics fully capable of dealing with and modeling EM energy from the vacuum. Yet, Dr. Evans lives in the United States (where he recently became a naturalized citizen) at the poverty level. He can afford only one meal a day, has no automobile, no air conditioning, and continues epochal work under a medical condition that would stop any ordinary person less scientifically dedicated. He continues to be vilified and viciously attacked by elements of the scientific community, even though other elements are of much assistance in publishing and reviewing his papers, etc. It is a remarkable commentary upon the sad state of our scientific community that such a scientist and such epochal work, of tremendous importance to both the United States and all humanity, must continue in such circumstances. Meanwhile, the scientific community spends billions on vast projects of little significance in general, and of no significance at all in avoiding the coming world economic collapse and the destruction of civilization. If this paper should fall into sympathetic hands which can obtain funding for Dr. Evans, then this author most fervently urges that such be accomplished at all speed. The fate of most of the civilized world may well hinge upon such a simple thing, and upon such an insignificant expenditure.

22. These are listed in M.W. Evans *et al.*, "Classical Electrodynamics Without the Lorentz Condition: Extracting Energy from the Vacuum," 2000, *ibid.*

23. This system exists in small working prototype already, but I am under a non-disclosure agreement and cannot reveal the details of the process or the identity and location of the inventor. The system is capable of being rapidly scaled up to meet the 2003 critical milestone of "ready for mass production". One can expect up to a COP = 4 from this process.

24. In an electrical power system, Coefficient of Performance (COP) may be taken as the average energy dissipated in the load divided by the average energy furnished to the system by the operator. Or, it may be taken as the average power dissipated in the load divided by the average power dissipated in the input process. COP can be taken across any component, several components, or the entire system. The COP of a normal generator itself may be 0.9, for example, while when the entire system including the heater, etc. is taken into account, the system COP may be only 0.3. For COP > 1.0, excess energy must be furnished to the system by the external environment, while only part of the energy (or none of it) is input by the operator.

25. The Kawai process, Johnson process, and the magnetic Wankel engine are ideal for this purpose.

26. T.E. Bearden, "Bedini's Method For Forming Negative Resistors In Batteries," *Proceedings of the IC-2000*, St. Petersburg, Russia, July 2000 (in press).

27. Teruo Kawai, "Motive Power Generating Device," U.S. Patent No. 5,436,518. Jul. 25, 1995. Applying the Kawai process to a magnetic motor essentially doubles the motor's efficiency. If one starts with high efficiency magnetic motors of, say, COP = 0.7 or 0.8, then the new COPs will be 1.4 and 1.6. Two Kawai-modified high efficiency Hitachi motors were in fact independently tested by Hitachi and yielded COP 1.4 and 1.6 respectively.

28. See T.E. Bearden, "The Master Principle of EM Overunity and the Japanese Overunity Engines," *Infinite Energy*, 1 (5&6), Nov. 1995—Feb. 1996, p. 38–55; "The Master Principle of Overunity and the Japanese Overunity Engines: A New Pearl Harbor?", *The Virtual Times*, Internet Node [www.hsv.com](http://www.hsv.com), Jan. 1996. The principle of the magnetic Wankel engine is self-evident from the drawings alone.

29. Johnson, Howard R., "Permanent Magnet Motor." U.S. Patent No. 4,151,431, Apr. 24, 1979; "Magnetic Force Generating Method and Apparatus," U.S. Patent No. 4,877,983, Oct. 31, 1989; "Magnetic Propulsion System," U.S. Patent No. 5,402,021, Mar. 28, 1995.

30. In magnetic materials, the presence of two electrons near each other and having parallel spins results in the presence of a very strong force tending to flip the spin so that they are antiparallel. The forces between the electrons due to spin geometry are exchange forces of quantum mechanical nature. In complex assemblies of different magnetic materials comprising a single stator or rotor magnet, the shapes and structures can be produced so that, as the rotor moves by the attracting stator and enters the usual back mmf zone, the powerful spin force is suddenly unleashed by the geometry, relative field strengths, and movement. This triggers the release of a violent pulse of magnetic field that greatly overrides the back mmf and strongly repels the rotor on out of this "gate" region where the exchange force is triggered. Exchange force pulses may momentarily be 1,000 times as strong as the magnetic field  $H$ , or in some cases even stronger. Evoking these responses automatically by the materials themselves, at controlled times and directions, produces the open system freely adding rotary energy from its vacuum exchanges inside the nonlinear materials. Johnson has been able to achieve this effect consistently, opening the way for a legitimate self-powering permanent magnet motor. We accent that the electrons involved are in direct energy exchange with the vacuum, and the exchange force energy comes from the violently broken symmetry in that vacuum exchange. Multivalued magnetic potentials and hence nonconservative magnetic fields arise naturally in magnetic theory anyway. However, conventional scientists exert enormous effort to eliminate such effects or minimize them—when in fact what is needed is to deliberately evoke and use them to produce systems with  $COP > 1.0$ .

31. Surrounding every dipolar EM circuit there exists a vast flow of nondiverged EM energy which misses the circuit entirely and is not presently accounted (thus "dark") in electrical power systems and circuit theory. Heaviside discovered it, Poynting never realized it, and Lorentz discarded it. He discarded it because (a) he reasoned it was physically insignificant since it did nothing in the circuit, and (b) no one had the foggiest notion where such an enormous flow of EM energy-pouring from the terminals of every battery and generator—could possibly be coming from. The trick Lorentz used to arbitrarily discard it is still used by electrodynamicists ubiquitously. For a full background, see T.E. Bearden, "Giant Negentropy from the Common Dipole," *Proc. IC-2000 (ibid.)*; "On Extracting Electromagnetic Energy from the Vacuum," *Proceedings of the IC-2000*, St. Petersburg, Russia, July 2000 (in press); "Dark Matter or Dark Energy?," *Journal of New Energy*, 2000 (in press).

32. Energy cannot be created or destroyed, but only changed in form. Changing the form of energy is called "work". When one joule of collected energy is "dissipated" to perform one joule of work, one still has one joule of energy remaining after that joule of work has been done. The energy is now just in a different form. Scattering of energy in a resistor, e.g., is perhaps the simplest way of performing work, and known as "joule heating". However, for a thought experiment: If the resistor is surrounded by a phase conjugate reflective mirror surface, much of the scattered energy will be precisely returned back to the resistor as re-ordered energy. It can indeed be "reused" by again being scattered in the resistor to do work. There is no conservation of work law in physics or thermodynamics! If there is no re-ordering at all, then one can get only one joule of work from one joule of energy changed in form. The remaining joule of energy in different form (as in heat) is just "wasted" from the system. But if we deliberately use re-ordering (such as simple passive retroreflection), we can reuse the same joule of energy to do joule after joule of work, changing the form of the energy in each interaction. Eerily, most of our scientists and engineers are aware that energy can be changed in form indefinitely without loss, but will then argue that energy cannot be recycled and reused. The scientific prejudice against " $COP > 1.0$ " processes and systems is so deep that many scientists are incapable of dealing with the real law of conservation of energy—which is simply that you can never get rid of any energy at all, but can only change its form. Every joule of energy in the universe, e.g., was present not long after the Big Bang. Since then, most of those joules of energy have each been doing joule after joule of work, for some 15 billion years.

33. Kenneth R. Shoulders, "Energy Conversion Using High Charge Density," U.S. Patent No. 5,018,180, May 21, 1991. See also Shoulders' patents 5,054,046 (1991); 5,054,047 (1991); 5,123,039 (1992), and 5,148,461 (1992). See also Ken Shoulders and Steve Shoulders, "Observations on the Role of Charge Clusters in Nuclear Cluster Reactions," *Journal of New Energy*, 1(3), Fall 1996, p. 111–121.

34. For a summary of this rapidly developing field, see Diederik Wiersma and Ad Legendijk, "Laser Action in Very White Paint," *Physics World*, Jan. 1997, p. 33–37.



35. For the early discovery, see V.S. Letokhov, "Generation of light by a scattering medium with negative resonance absorption," *Zh. Eksp. Teor. Fiz.*, Vol. 53, 1967, p. 1442; *Soviet Physics JETP*, Vol. 26, 1968, p. 835–839; "Laser Maxwell's Demon," *Contemp. Phys.*, 36(4), 1995, p. 235–243. For initiating experiments although with external excitation of the medium, see N.M. Lawandy *et al.*, "Laser action in strongly scattering media," *Nature*, 368(6470), Mar. 31, 1994, p. 436–438. See also D.S. Wiersma, M.P. van Albada, and A. Lagendijk, *Nature*, Vol. 373, 1995, p. 103.

36. For new effects, see D.S. Wiersma and Ad. Lagendijk, "Light diffusion with gain and random lasers," *Phys. Rev. E*, 54(4), 1996, p. 4256–4265; D.S. Wiersma, Meint. P. van Albada, Bart A. van Tiggelen, and Ad Lagendijk, "Experimental Evidence for Recurring Multiple Scattering Events of Light in Disordered Media," *Phys. Rev. Lett.*, 74(21), 1995, p. 4193–4196; D.S. Wiersma, M.P. Van Albada, and A. Lagendijk, *Phys. Rev. Lett.*, Vol. 75, 1995, p. 1739; D.S. Wiersma *et al.*, *Nature*, Vol. 390, 1997, p. 671–673; F. Sheffold *et al.*, *Nature*, Vol. 398, 1999, p. 206; J. Gomez Rivas *et al.*, *Europhys. Lett.*, 48(1), 1999, p. 22–28; Gijs van Soest, Makoto Tomita, and Ad Lagendijk, "Amplifying volume in scattering media," *Opt. Lett.*, 24(5), 1999, p. 306–308; A. Kirchner, K. Busch and C. M. Soukoulis, *Phys. Rev. B*, Vol. 57, 1998, p. 277.

37. A true negative resistor appears to have been developed by the renowned Gabriel Kron, who was never permitted to reveal its construction or specifically reveal its development. For an oblique statement of his negative resistor success, see Gabriel Kron, "Numerical solution of ordinary and partial differential equations by means of equivalent circuits," *J. Appl. Phys.*, Vol. 16, Mar. 1945a, p. 173. Quoting: "When only positive and negative real numbers exist, it is customary to replace a positive resistance by an inductance and a negative resistance by a capacitor (since none or only a few negative resistances exist on practical network analyzers)." Apparently Kron was required to insert the words "none or" in that statement. See also Gabriel Kron, "Electric circuit models of the Schrödinger equation," *Phys. Rev.* 67(1–2), Jan. 1 and 15, 1945, p. 39. We quote: "Although negative resistances are available for use with a network analyzer, . . ." Here the introductory clause states in rather certain terms that negative resistors were available for use on the network analyzer, and Kron slipped this one through the censors. It may be of interest that Kron was a mentor of Floyd Sweet, who was his protégé. Sweet worked for the same company, but not on the Network Analyzer project. However, he almost certainly knew the secret of Kron's "open path" discovery and his negative resistor. The present author worked for several years with Sweet, who produced a solid state device (the magnetic Vacuum Triode Amplifier) with no moving parts which produced 500 watts of output power for some 33 microwatts of input power. See Floyd Sweet and T.E. Bearden, "Utilizing Scalar Electromagnetics to Tap Vacuum Energy," *Proc. 26th Intersoc. Energy Conversion Engineering Conf. (IECEC 1991)*, Boston, Massachusetts, p. 370–375.

38. Shoukai Wang and D.D.L. Chung, "Apparent negative electrical resistance in carbon fiber composites," *Composites, Part B*, Vol. 30, 1999, p. 579–590. Negative electrical resistance was observed, quantified, and controlled through composite engineering by Chung and her team. Electrons were caused to flow backward against the voltage, with backflow across a composite interface. The team was able to control the manufacturing process to produce either positive or negative resistance as desired. The University at Buffalo filed a patent application. It first placed a solicitation to industry for developments, and offered a technical package to interested companies signing nondisclosure, then suddenly withdrew the offer. It appears to this author that a "fix" may be in place on the development.

39. It is common knowledge that the point-contact transistor could be manufactured to produce a true negative resistor where the output current moved against the voltage. E.g., see William B. Burford III and H. Grey Verner. *Semiconductor Junctions and Devices: Theory to Practice*, McGraw-Hill, New York, 1965. Chapter 18: Point-Contact Devices. Quoting from p. 281: "First, the theory underlying their function is imperfectly understood even after almost a century . . . , and second, they involve active metal-semiconductor contacts of a highly specialized nature. . . . The manufacturing process is deceptively simple, but since much of it involves the empirical know-how of the fabricator, the true variables are almost impossible to isolate or study. . . . although the very nature of these units limits them to small power capabilities, the concept of small-signal behavior, in the sense of the term when applied to junction devices, is meaningless, since there is no region of operation wherein equilibrium or theoretical performance is observed. Point-contact devices may therefore be described as sharply nonlinear under all operating conditions." We point out that the power limitation can be overcome by arrays of multiple point contacts placed closely together.

40. It is the back coupling of the magnetic field from the secondary to the primary windings that forces the dissipation of equal energy in the primary of the transformer as is dissipated in the secondary. If part of the return current in the secondary circuit bypasses the secondary of the transformer, the back field coupling to the primary is reduced accordingly. Using a negative resistor as the bypass, the bypass of the current is “for free” (powered by the vacuum and a negentropic process). Hence the result is a transformer/bypass system with  $COP > 1.0$ . In that case, such a system can have a positive clamped feedback from the output of the secondary circuit, into the primary to power it, while still having energy remaining to power a load. No laws of physics or thermodynamics are violated, once one understands how an EM circuit is actually powered. E.g., see Bearden, “On Extracting EM Energy from the Vacuum, 2000, (*ibid.*).

41. The Kawai process was seized in the personal presence of the present author and his CTEC, Inc. Board of Directors. We had reached a full agreement with Kawai to manufacture and sell his units worldwide, at great speed. Control of his company, his invention, and Kawai himself was taken over in our presence the next morning, and the Japanese contingent was in fear and trembling.

42. The magnetic Wankel engine was developed and actually placed in a Mazda automobile. The back mmf of the rotary permanent magnet motor is confined to a very small angle of the rotation. As the rotor enters that region, a sudden cutoff of a small trickle current in a coil generates a momentary large Lenz law effect which overrides the back mmf and produces a forward mmf in that region. The result is that one furnishes a small bit of energy to convert the engine to a rotary permanent magnet motor with no back mmf, but with a nonconservative net magnetic field. For details, see T.E. Bearden, “The Master Principle of EM Overunity and the Japanese Overunity Engines,” *Infinite Energy*, 1(5&6), Nov. 1995—Feb. 1996, p. 38–55; “The Master Principle of Overunity and the Japanese Overunity Engines: A New Pearl Harbor?”, *The Virtual Times*, Internet Node [www.hsv.com](http://www.hsv.com), Jan. 1996.

43. For a history and present status of Japanese organized crime, see Adam Johnston, “Yakuza: Past and Present,” Committee for a Safe Society, Organized Crime Page: Japan (available on the Internet). Michael Hirsh and Hideko Takayama, “Big Bang or Bust?” *Newsweek*, Sept. 1, 1997, p. 44–45.

44. As a ball-park figure for illustration, a nominal electrical circuit or power system actually extracts from the vacuum and pours out into space some 10 trillion times as much energy flow as the poorly designed “single pass” circuits intercept and utilize.

45. However, the orthodox scientists do not know it, because they follow blindly the method introduced by Lorentz a century ago. Lorentz arbitrarily discarded all that astounding energy flow that pours from the source dipole and misses the circuit, and retained only the tiny, tiny bit of it that strikes the circuit and enters it to power it. Nothing at all has been done since then to capture more of that huge available energy and use it. As a result of the ubiquitous Lorentz procedure, most electrical power system scientists and engineers are no longer aware that the huge unaccounted energy flow not striking the circuit even exists.

46. The active vacuum interacts profusely with every electrodynamic system, but this is not modeled at all by the scientists and engineers designing and building electrical power systems. They unwittingly design every system to enforce Lorentz symmetrical regauging during excitation energy discharge, which in effect forces equilibrium in the vacuum-system energy exchange during that dissipation. Hence, classical equilibrium thermodynamics rigorously applies during use of the collected energy. Such systems are limited to  $COP < 1.0$  *a priori*.

47. In Nobelist Feynman’s words: “We . . . wish to emphasize . . . the following points: (1) the electromagnetic theory predicts the existence of an electromagnetic mass, but it also falls on its face in doing so, because it does not produce a consistent theory—and the same is true with the quantum modifications; (2) there is experimental evidence for the existence of electromagnetic mass, and (3) all these masses are roughly the same as the mass of an electron. So we come back again to the original idea of Lorentz—maybe all the mass of an electron is purely electromagnetic, maybe the whole 0.511 Mev is due to electrodynamics. Is it or isn’t it? We haven’t got a theory, so we cannot say. Richard P. Feynman, Robert B. Leighton, and Matthew Sands, *Lectures on Physics*, Vol. 2, 1964, p. 28–12. Also: “We do not know how to make a consistent theory—including the quantum mechanics—which does not produce an infinity for the self-energy of an electron, or any point charge. And at the same time, there is no satisfactory theory that describes a non-point charge. It’s an unsolved problem.” *Ibid.*, Vol. 2, 1964, p. 28–10. In fact, “energy” itself is actually a very nebulous and inexact concept. Again quoting: “It is impor-

tant to realize that in physics today, we have no knowledge of what energy *is*." *Ibid.*, Vol. 1, 1964, p. 4–2.

48. E.g., a very recent AIAS paper, M.W. Evans et al., "The Most General Form of Electrodynamics," submitted to *Physica Scripta*, rigorously shows just how wrong the present limited EM theory is. ". . . there can be no electro-magnetic field [as such] in the vacuum. In other words, there can be no electromagnetic field propagating in a source-free region as in the Maxwell–Heaviside theory, which is written in flat space-time using ordinary derivatives instead of covariant derivatives." The reason is quite simple: spacetime is active and curved. The great John Wheeler and Nobelist Feynman, e.g., realized that EM force fields cannot exist in space. They pointed out that only the potential for such fields existed in space, should some charges be made available so that the fields could be developed on them. See Richard P. Feynman, Robert B. Leighton and Matthew Sands, *The Feynman Lectures on Physics*, Addison–Wesley, New York, Vol. I, 1963, p. 2–4.

49. Max Planck, as quoted in G. Holton, *Thematic Origins of Scientific Thought*, Harvard University Press, Cambridge, MA, 1973.

50. Arthur C. Clarke, in "Space Drive: A Fantasy That Could Become Reality" NSS . . . AD ASTRA, Nov/Dec 1994, p. 38.

51. E.g., quoting Nobelist Lee: ". . . the discoveries made in 1957 established not only right-left asymmetry, but also the asymmetry between the positive and negative signs of electric charge. . . . "Since non-observables imply symmetry, these discoveries of asymmetry must imply observables." T.D. Lee, *Particle Physics and Introduction to Field Theory*, Harwood, New York, 1981, p. 184.] On p. 383, Lee points out that the microstructure of the scalar vacuum field (i.e., of vacuum charge) is not utilized. Particularly see Lee's own attempt to indicate the possibility of using vacuum engineering, in his "Chapter 25: Outlook: Possibility of Vacuum Engineering," p. 824–828. Unfortunately Lee was unaware of Whittaker's profound 1903 decomposition of the scalar potential, as between the ends of a dipole, which gives a much more practical and easily evoked method for re-ordering some of the vacuum's energy, extracting copious EM energy flows from it, and setting the stage for self-powering electrical power systems worldwide.

52. The present author has taken the necessary first major step, by using Whittaker decomposition of the scalar potential between the poles of a dipole to reveal a simple, direct, cheap method for extracting and sustaining enormous EM energy flows from the dipole's asymmetry in its energetic exchange with the active vacuum.

53. The internal energy available to a generator is the shaft energy we input to it. In large power plants this is usually by a steam turbine, and heat (from a nuclear reactor, burning hydrocarbons, etc.) is used merely to heat the water in the boiler to make steam to run the steam turbine. Every bit of all that is just so the generator will have some internal energy made available with which it can then forcibly make the dipole. That is all that generators (and batteries) do: Use their available internal energy to continually make the source dipole—which our engineers design the circuit to keep destroying faster than the load is powered.

54. By "dipole" we mean the positive charges are forced to one side, and the negative charges forced to the other. This internal "source dipole" formed by the generator or battery is electrically connected to the terminals.

55. This has been known in particle physics for nearly 50 years. It stems from the discovery of broken symmetry by C.S. Wu *et al.* in 1957. A dipole is known to be a broken symmetry in its violent energy exchange with the active vacuum. Rigorously this means that some of the "disordered" EM energy received by the dipole from the vacuum, is re-ordered and re-radiated as usable, observable EM energy. Conventional electrodynamics and power system engineering do not model the vacuum's interaction, much less the broken symmetry of the generator or battery dipole in that continuous energy exchange.

56. A pictorial illustration of the enormity of the energy flow through the surrounding space, and missing the external circuit entirely, is given by John D. Kraus, *Electromagnetics*, Fourth Edn., McGraw–Hill, New York, 1992—a standard university text. Figure 12–60, a and b, p. 578 shows a good drawing of the huge energy flow filling all space around the conductors, with almost all of that energy flow not intercepted by the circuit at all, and thus not diverged into the circuit to power it, but just "wasted" by passing it on out into space.

57. That is, the interception of the little "boundary layer" or "sheath" of the flow, right on the surface of the wires.

58. Poynting never considered anything but this small little "intercepted" component of the energy flow that actually entered the circuit. E.g., see J.H. Poynting, "On the connexion between electric current and the electric and magnetic inductions in the surrounding field," *Proc. Roy. Soc. Lond.*, Vol. 38, 1985, p. 168.

59. In technical terms, the closed current loop circuit forces the Lorentz symmetrical regauging condition during the discharge of the excitation energy collected by the circuit. By definition, half the energy is thus used to oppose the system function (i.e., to destroy the source dipole) while the other half of the excitation energy is used to power the external losses and the load. With half the collected energy used to destroy the free extraction of energy from the vacuum, and less than half used to power the load, these ubiquitous circuits destroy their source of free vacuum energy faster than they power their loads. Hence, we ourselves have to steadily input shaft energy to the generators so that they can continue to reform the dipole. In the vernacular, that is not the way to run the railroad!

60. Maxwell's seminal paper was published in 1864, as a purely material fluid flow (hydrodynamic) theory. At the time, the electron and the atom had not been discovered, hence the reaction of two opposite charges (positive nuclei, negative Drude electrons) in the wire was not modeled but only one was modeled, etc. Maxwell omitted half the EM wave in the vacuum and half the energy, resulting in the omission of the EM cause and generatrix of Newton's third law reaction from electrodynamics. This omission is present in electrodynamics, where the third law reaction appears as a mystical effect without a known cause. The cause and mechanism is the omitted reaction of the observed effect back upon the non-observed cause. General relativity, e.g., does include this reaction mechanism from the effect back upon the cause. However, electrodynamicists still omit half the electromagnetics, half the wave, and half the energy as is easily shown. E.g., it is demonstrated in every EM signal reception in a simple wire antenna, when the resulting perturbations of both the positive nuclei and the Drude electrons are correctly attributed to their interactions with the incoming EM fields (waves) from the vacuum.

61. Mario Bunge, *Foundations of Physics*, Springer-Verlag, New York, 1967, p. 176.

62. T.E. Bearden, "On Extracting Electromagnetic Energy from the Vacuum," *Proc. IC-2000*, St. Petersburg, Russia, July 2000 (in press).

63. T.E. Bearden, "Bedini's Method For Forming Negative Resistors In Batteries," *Proc. IC-2000*, St. Petersburg, Russia, July 2000 (in press).

64. T.E. Bearden, "Giant Negentropy from the Common Dipole," *Proc. IC-2000*, St. Petersburg, Russia, July 2000 (in press).

65. E.g., a good short summary is given by Dr. Theodore Loder, Institute for the Study of Earth, Oceans, and Space (EOS), University of New Hampshire, Durham, NH in his short paper, "Comparative Risk Issues Regarding Present and Future Environmental Trends: Why We Need to be Looking Ahead Now!", prepared for the Senate Committee on the Environment and Public Works, June 1, 2000. Certainly Dr. Loder and EOS can fully expound on the details of the biospheric pollution from the various contributing factors and processes.

66. One need only regard the vehement attacks by the scientific community (and much of the government including national laboratories) upon cold fusion researchers, to understand why many inventors and scientists in the COP>1.0 open dissipative energy field are openly distrustful of the government and government scientists. Further, the U.S. Patent Office is known to be under rather explicit instructions not to issue patents on COP>1.0 electrical processes and systems.

67. E.g., the well-known Bohren experiment produces 18 times as much energy output as the operator must input. The excess energy is extracted directly from the vacuum. There has been no program, to my knowledge, seeking to exploit this well-proven COP>1.0 mechanism that has been in the hard science literature for some time. See Craig F. Bohren, "How can a particle absorb more than the light incident on it?" *Am. J. Phys.*, 51(4), Apr. 1983, p. 323-327. Under nonlinear conditions, a particle can absorb more energy than is in the light incident on it. Metallic particles at ultraviolet frequencies are one class of such particles and insulating particles at infrared frequencies are another. For independent validation of the Bohren phenomenon, see H. Paul and R. Fischer, Comment on "How can a particle absorb more than the light incident on it?" *Am. J. Phys.*, 51(4), Apr. 1983, p. 327.

68. G. Johnstone Stoney, "Microscopic Vision," *Phil. Mag.* Vol. 42, Oct. 1896, p. 332; "On the Generality of a New Theorem," *Phil. Mag.*, Vol. 43, 1897, p. 139-142; "Discussion of a New Theorem in Wave Propagation," *Phil. Mag.*, Vol. 43, 1897, p. 273-280; "On a Supposed Proof of a Theorem in Wave-motion," *Phil. Mag.*, Vol. 43, 1897, p. 368-373.

69. E. T. Whittaker, "On the Partial Differential Equations of Mathematical Physics," *Math. Ann.*, Vol. 57, 1903, p. 333-355.

70. Evans in a private communication has pointed out that Whittaker's method depends upon the Lorentz gauge being assumed. If the latter is not used, the Whittaker method is inadequate, because the scalar potential becomes even more richly structured. My restudy of the problem with this in mind concluded that, for the

negentropic vacuum-reordering mechanism involving only the dipole and the charge as a *composite* dipole, it appears that the Whittaker method can be applied without problem, at least to generate the minimum negentropic process itself. However, this still leaves open the possibility of additional structuring. The actual negentropic reordering of the vacuum energy (and the structure of the outpouring of the EM energy 3-flow from the charge or dipole) may permissibly be much richer than given by the simple Whittaker structure alone. In other words, the Whittaker structure used in this paper should be regarded as the *simplest* structuring of the negentropic process that can be produced, and hence as a lower boundary condition on the process.

71. Time-like currents and flows do appear in the vacuum energy, if extended electrodynamic theory is utilized. E.g., in the received view the Gupta-Bleuler method removes time-like photons and longitudinal photons. For disproof of the Gupta-Bleuler method, proof of the independent existence of such photons, and a short description of their characteristics, see Myron W. Evans et al., AIAS group paper, "On Whittaker's F and G Fluxes, Part III: The Existence of Physical Longitudinal and Time-Like Photons," *J. New Energy*, 4(3), Winter 1999, p. 68-71; "On Whittaker's Analysis of the Electromagnetic Entity, Part IV: Longitudinal Magnetic Flux and Time-Like Potential without Vector Potential and without Electric and Magnetic Fields," *ibid.*, p. 72-75. To see how such entities produce ordinary EM fields and energy in vacuo, see Myron W. Evans et al., AIAS group paper, "On Whittaker's Representation of the Electromagnetic Entity in Vacuo, Part V: The Production of Transverse Fields and Energy by Scalar Interferometry," *ibid.*, p. 76-78. See also Myron W. Evans et al., AIAS group paper, "Representation of the Vacuum Electromagnetic Field in Terms of Longitudinal and Time-like Potentials: Canonical Quantization," *ibid.*, p. 82-88.

72. For a short treatise on the complex Poynting vector, see D.S. Jones, *The Theory of Electromagnetism*, Pergamon Press, Oxford, 1964, p. 57-58. In a sense our present use is similar to the complex Poynting energy flow vector, but in our usage the absolute value of the imaginary energy flow is equal to the absolute value of the real energy flow, and there is a transformation process in between. This usage is possible because the imaginary flow is into a *transducer*, which takes care of transforming the received *imaginary* EM energy into the output real EM energy. We stress that the word "imaginary" is not at all synonymous with *fictitious*, but merely refers to what "dimension" or state the EM energy exists in.

73. Unfortunately, electrical engineers use the term "power" to also mean the rate of energy flow, when rigorously the term "power" means the rate at which work is done. We accent that we fully understand the difference, but are using the terminology common to the profession.

74. Nobelist Prigogine experienced something very similar when he proposed his open dissipative systems, where the system operations did not lead to the conventional increasing disorder. To say that he was subjected to the Inquisition is not an exaggeration. Other scientists have repeatedly been subjected to intense scientific attack and suppression—including Mayer (conservation of energy), Einstein (relativity), Wegener (drifting continental plates), Ovshinsky (amorphous semiconductors), to name just a few of the hundreds who have been attacked in similar fashion. Science does not proceed by sweet reason, but by a vicious dogfight with no holds barred. It delights in "wolf pack" attacks upon the scientist with a new idea or discovery.

75. And the scientific community is certainly not prepared for the notion of using time as energy, freely and anywhere. In a sense, one can "burn time as fuel". Consider this: In physics, the choice of fundamental units in one's physics model is completely arbitrary. E.g., one can make a quite legitimate physics model having only a single fundamental unit (such is already done in certain areas of physics). E.g., suppose we make the "joule" (energy) the only fundamental unit. It follows then that everything else—including the *second* and therefore *time*—is a function of energy. One can utilize the second as  $c^2$  joules of energy. Hence, the flow of time would have the same energy density as mass. After Einstein, the atom bomb, and the nuclear reactor, of course, we are all comfortable with the fact that mass is just spatial energy compressed by the factor  $c^2$ . So we really should not be too uncomfortable at the notion that time itself is energy compressed by the factor  $c^2$ . In this case, if every second of the passage of time, we were to convert one microsecond into ordinary EM spatial energy, we would produce some  $9 \times 10^{10}$  joules of EM energy. Since that is done each second, this would give us the equivalent of the output of 90 1000-megawatt power plants. If only 1.11 percent efficient, the conversion process would yield the equivalent of one 1000-megawatt power plant.

In fact, it is in theory possible to do such a conversion, and we have previously indicated the various mechanisms involved. There are also some rough experimental

results that are at least consistent with the thesis. The interested reader is referred to T.E. Bearden, "EM Corrections Enabling a Practical Unified Field Theory with Emphasis on Time-Charging Interactions of Longitudinal EM Waves," *J. New Energy*, 3(2/3), 1998, p. 12–28. See also the author's similar paper with the same title, in *Explore*, 8(6), 1998, p. 7–16. We believe that the real energy technology for the second half of this century is based on use of time for fuel. The fundamental reactions and principles also enable a totally new form of high energy physics reactions, where very low spatial energy photons are the carriers (their time components carry canonical time-energy, so that the highest energy photons of all, given time-energy conversion, are low frequency photons. These new reactions (given in the references cited) are indeed consistent with the startling nuclear transformation reactions met at low (spatial) photon energies in hundreds of successful cold fusion experiments worldwide.

76. A classic example is given by Paul Nahin in his *Oliver Heaviside: Sage in Solitude*, IEEE Press, New York, 1988, p. 225. Quoting: "J.J. Waterston's paper on the kinetic theory of gases, in 1845, was rejected by the Royal Society of London. One of the referees declared it to be 'nothing but nonsense, unfit even for reading before the Society.' . . . 'Waterston's dusty manuscript was finally exhumed from its archival tomb 40 years later, because of the efforts of Lord Rayleigh . . ." Our comment is that the same scientific attitude and resistance to innovative change prevails today. As the French say, "Plus ca change, plus c'est la meame chose!"

77. E.g., see G. Nicolas and I. Prigogine, *Exploring Complexity*, Piper, Munich, 1987 (an English version is *Exploring Complexity: An Introduction*, Freeman, New York, 1989); Ilya Prigogine, *From Being to Becoming: Time and Complexity in the Physical Sciences*, W.H. Freeman and Company, San Francisco, 1980. In 1977, Prigogine received the Nobel Prize in chemistry for his contributions to nonequilibrium thermodynamics, especially the theory of dissipative structures.

78. E.g., see, Moisés Naim, "Lori's War," *Foreign Policy*, Vol. 118, Spring 2000, p. 28–55. See particularly Lori Wallach and Michelle Sforza, *Whose Trade Organization? Corporate Globalization and the Erosion of Democracy*, published by Public Citizen Foundation and available by order from <http://www.globaltradewatch.org>. Perusal of the leading environmental activist web sites now shows a significant and rising awareness that globalization is merely the surface facade of an older, imperial, feudalistic capitalism where checks and balances established by national states are being slowly and methodically bypassed.

79. The interested reader is referred to Andrew A. Marino, *Powerline Electromagnetic Fields and Human Health*, at <http://www.ortho.lsumc.edu/Faculty/Marino/Marino.html>. Particularly see "Chapter 5, Blue-Ribbon Committees and Powerline EMF Health Hazards," and "Chapter 6: Power-Industry Science and Powerline EMF Health Hazards." Biophysicist Marino is one of the leaders in the field and has been personally involved in many skirmishes with powerline-dominated studies and findings. As an example, quoting from Chapter 6: "Neither scientists nor the public can rely on power-industry research or analysis to help decide whether powerline electromagnetic fields affect human health because power-industry research and analysis are radically misleading." There are many other reports in the literature, which also show effects of EM nonionizing radiation on cells, including detrimental effects.

80. Becker studied not just the immune system—which "heals" nothing at all, not even its own damaged cells—but also the cellular regenerative system. He and others found, e.g., that tiny trickle currents and potentials—either steady or pulsed—placed across otherwise intractable bone fractures, would result in a rather astounding set of cellular changes which led to healing of the fracture by deposit of new bone. Eerily, Becker showed that the red blood cells coming into the area and under the EM influence, would shuck their hemoglobin and grow cellular nuclei (i.e., dedifferentiate back to an earlier cellular state). Then these cells would redifferentiate into the type of cells that made cartilage. Then those cells would differentiate into the type of cells that make bone, and be deposited in the fracture to "grow bone" and heal the fracture. Incredibly, this is the only true "healing" modality in all Western medical science—which is otherwise built upon the theory of intervention rather than healing. After the intervention (which may be quite necessary!), the body's cellular regenerative system—or what is left of it after damage by such interventions as chemotherapy, etc.—is left entirely upon its own to restore the damage (heal the damaged cells and tissues). Becker was twice nominated for a Nobel Prize. However, because he also testified in court against power companies, giving testimony as an expert witness that EM radiation from power lines could indeed induce harmful conditions in some exposed people, he was suppressed and eventually forced to retire.

81. See Robert O. Becker and Andrew A. Marino, *Electromagnetism and Life*, State University of New York Press, Albany, 1982. This reference gives a nice summary of EM bioeffects from the orthodox view, current as of the publication date. For Becker's work with the cellular regenerative system, see particularly R.O. Becker, "The neural semiconduction control system and its interaction with applied electrical current and magnetic fields," *Proc. XI Internat. Congr. Radiol.*, Vol. 105, 1966, p. 1753–1759, Excerpta Medica Foundation, Amsterdam. See Becker, "The direct current field: A primitive control and communication system related to growth processes," *Proc. XVI Internat. Congr. Zool.*, Washington, DC, Vol. 3, 1963, p. 179–183.

82. For an overview of the ansatz of present battery technology, see David Linden, Editor in Chief, *Handbook of Batteries*, Second Edition, McGraw Hill, New York, 1995; Colin A. Vincent and Bruno Scrosati, *Modern Batteries: An Introduction to Electrochemical Power Sources*, Second Edition, Wiley, New York, 1997. For a process to make a battery include a negative resistor and exhibit COP>1.0, see Bearden, "Bedini's Method For Forming Negative Resistors In Batteries," *Proc. IC-2000*, St. Petersburg, Russia (in press).

83. Such laboratories are private and professional testing companies, where the U.S. Government has certified their expertise and qualifications, their testing to NIST, IEEE, and U.S. Government standards, their use of calibrated instruments, and the experience and ability of their professional test engineers and scientists. Such labs are routinely and widely used by aerospace firms. A Test Certificate from such a lab is acceptable by the courts, the U.S. Patent and Trademark Office, the U.S. Government (which requires it on many contracts), and by the U.S. scientific community. A goodly number of these laboratories are available throughout the United States

84. A few struggling publications in the "new energy" field are crucial to continued progress. The major ones are *Journal of New Energy* (Dr. Hal Fox, publisher), *Infinite Energy* (Dr. Eugene Mallove, publisher), and *Explore* (Chrystyne Jackson, publisher). Independent sustaining funding for these publications is urgently needed. We also highly commend the Department of Energy's Transportation group for maintaining a DOE website carrying the advanced electrodynamics papers of the Alpha Foundation's Institute for Advanced Study (AIAS). Funding for the AIAS is also urgently needed, to continue this absolutely essential theoretical work that is placing a solid physics foundation under the program of extracting and using EM energy from the vacuum.

85. Some recommended publications of interest are: Joshua Lederberg, Editor, *Biological Weapons: Limiting the Threat*, MIT Press, Cambridge, MA, 1999, with a foreword by Defense Secretary William S. Cohen; Richard A. Falkenrath, Robert D. Newman, and Bradley A. Thayer, *America's Achilles Heel: Nuclear, Biological, and Chemical Terrorism and Covert Attack*, MIT Press, 1998; Wendy Barnaby, *The Plague Makers: The Secret World of Biological Warfare*, Vision Paperbacks, Satin Publications Ltd., London, 1999 (a most readable and educational book for the non-specialist), U.S. Congress, Office of Technology Assessment, *Proliferation of Weapons of Mass Destruction: Assessing the Risks*, Government Printing Office, Washington, DC, 1993 (a major study on WMD and the risks to the United States, including to the U.S. civilian population); *Global Proliferation of Weapons of Mass Destruction*, Part I, Senate Hearing 104–422, Hearings Before the Permanent Subcommittee on Investigations of the Committee on Governmental Affairs, U.S. Senate, Oct. 31 and Nov. 1, 1995.

86. Unfortunately, the extant unclassified references on longitudinal EM and more advanced EM weapons seem to be the publications by the present author, e.g., T.E. Bearden, "Mind Control and EM Wave Polarization Transductions, Part I," *Explore*, 9(2), 1999, p. 59; Part II, *Explore*, 9(3), 1999, p. 61; Part III, *Explore*, 9(4,5), 1999, p. 100–108;—"EM Corrections Enabling a Practical Unified Field Theory with Emphasis on Time-Charging Interactions of Longitudinal EM Waves," *Journal of New Energy*, 3(2/3), 1998, p. 12–28;—*Energetics of Free Energy Systems and Vacuum Engine Therapies*, Tara Publishing, Internet node [www.tarapublishing.com/books](http://www.tarapublishing.com/books), July 1997;—*Gravitobiology: A New Biophysics*, Tesla Book Co., P.O. Box 121873, Chula Vista, CA 91912, 1991;—*Fer-de-Lance*, Tesla Book Co., 1986;—*AIDS: Biological Warfare*, Tesla Book Co., 1988;—*Soviet Weather Engineering Over North America*, 1-hour videotape, 1985;—*Energetics: Extensions to Physics and Advanced Technology for Medical and Military Applications*, CTEC Proprietary, May 1, 1998, 200+ page inclosure to CTEC Letter, "Saving the Lives of mass BW Casualties from Terrorist BW Strikes on U.S. Population Centers," to Major General Thomas H. Neary, Director of Nuclear and Counterproliferation, Office of the Deputy Chief of Staff, Air and Space Operations, HQ USAF, May. 4, 1998;—"Overview and Background of KGB Energetics Weapons Threat to the United States," updated Jan. 3, 1999, furnished to selected Senators and Congresspersons.

87. As an example, for decades Castro ran guerrilla and agent training camps in Southern Mexico. Many of the graduates of those camps—trained terrorists all—have been infiltrated across the U.S. border and into the United States, to bide their time and wait for instructions. Some estimates are that several thousand such Castro agents alone are already onsite and positioned for sabotage, poisoning of water supplies, destruction of transmission line towers, destruction of key bridges, etc. Several other nations hostile to the United States are also known to have agent teams already onsite within the United States. The new form of warfare/terrorism is to introduce the “troops” into the adversary’s nation and populace in advance, as well as weapons caches, etc. So such preparations have definitely been accomplished within the United States, and undoubtedly some are still in progress and ongoing.

88. E.g., see Stanislov Lunev and Ira Winkler, 1998, *ibid.* p. 22: “Though most Americans don’t realize it, America is already penetrated by Russian military intelligence to the extent that arms caches lie in wait for use by Russian special forces—or Spetznatz.”

Page 26: “It is surprisingly easy to smuggle nuclear weapons into the United States. A commonly used method is for a Russian airplane to fly across the ocean on a typical reconnaissance flight. The planes will be tracked by U.S. radar, but that’s not a problem. When there are no other aircraft in visual range, the Russian airplane will launch a small, high-tech, stealth transport missile that can slip undetected into remote areas of the country. The missiles are retrieved by GRU operatives.

Another way to get a weapon into the country is to have an “oceanographic research” submarine deliver the device—accompanied by GRU specialists—to a remote section of coastline.

Nuclear devices can also be slipped across the Mexican or Canadian borders. It is easy to get a bomb to Cuba and from there transport it to Mexico. Usually the devices are carried by a Russian intelligence officer or a trusted agent.”

