

federal register

FRIDAY, NOVEMBER 12, 1971

WASHINGTON, D.C.

Volume 36 ■ Number 219

Pages 21659-21745



HIGHLIGHTS OF THIS ISSUE

This listing does not affect the legal status of any document published in this issue. Detailed table of contents appears inside.

- LOANS AND GRANTS**—USDA regulation regarding proposed construction in flood plain areas 21666
- WATER AND WASTE DISPOSAL SYSTEMS**—USDA regulation regarding proposed construction in flood plain areas 21666
- SAVINGS AND LOAN ASSOCIATIONS**—FHLBB amendments relating to reserves and net income for FSLIC-insured institutions; effective 11-12-71 21667
- HOSPITAL MORTGAGE INSURANCE**—HUD regulations on inclusion of proprietary hospitals; effective 11-12-71 21674
- LAND MOBILE REGIONAL PROGRAM**—FCC regulation for mobile radio user's in Regional Spectrum Management Program; effective 12-23-71 21677
- LIVE POULTRY**—USDA proposal for weighing live poultry and testing scales used in purchase, sale or acquisition of live poultry; comments within 60 days 21683
- OCCUPATIONAL SAFETY AND HEALTH**—Labor Dept. proposal on recording and reporting occupational injuries and illnesses; comments within 20 days 21687
- CANNED FOOD**—FDA notice of petition proposing statement of policy re commercially processed foods in hermetically sealed containers; comments within 60 days 21688
- BLOOD**—HEW proposal modifying requirement for periodic check on sterile technique; comments within 30 days 21696

(Continued Inside)

**MICROFILM EDITION
FEDERAL REGISTER
35mm MICROFILM**

Complete Set 1936-70, 189 Rolls \$1,342

Vol.	Year	Price	Vol.	Year	Price	Vol.	Year	Price
1	1936	\$7	13	1948	\$28	25	1960	\$49
2	1937	12	14	1949	22	26	1961	44
3	1938	8	15	1950	28	27	1962	46
4	1939	14	16	1951	44	28	1963	50
5	1940	14	17	1952	41	29	1964	54
6	1941	21	18	1953	30	30	1965	58
7	1942	37	19	1954	37	31	1966	60
8	1943	53	20	1955	41	32	1967	69
9	1944	42	21	1956	42	33	1968	55
10	1945	47	22	1957	41	34	1969	62
11	1946	47	23	1958	41	35	1970	59
12	1947	24	24	1959	42			

Order Microfilm Edition from Publications Sales Branch
National Archives and Records Service
Washington, D.C. 20408



(49 Stat. 500, as amended; 44 U.S.C., Ch. 15), under regulations prescribed by the Administrative Committee of the Federal Register, approved by the President (1 CFR Ch. I). Distribution is made only by the Superintendent of Documents, U.S. Government Printing Office, Washington, D.C. 20402.

The FEDERAL REGISTER will be furnished by mail to subscribers, free of postage, for \$2.50 per month or \$25 per year, payable in advance. The charge for individual copies is 20 cents for each issue, or 20 cents for each group of pages as actually bound. Remit check or money order, made payable to the Superintendent of Documents, U.S. Government Printing Office, Washington, D.C. 20402.

The regulatory material appearing herein is keyed to the CODE OF FEDERAL REGULATIONS, which is published, under 50 titles, pursuant to section 11 of the Federal Register Act, as amended (44 U.S.C. 1510). The CODE OF FEDERAL REGULATIONS is sold by the Superintendent of Documents. Prices of new books are listed in the first FEDERAL REGISTER issue of each month.

There are no restrictions on the republication of material appearing in the FEDERAL REGISTER or the CODE OF FEDERAL REGULATIONS.

Published daily, Tuesday through Saturday (no publication on Sundays, Mondays, or on the day after an official Federal holiday), by the Office of the Federal Register, National Archives and Records Service, General Services Administration, Washington, D.C. 20408, pursuant to the authority contained in the Federal Register Act, approved July 26, 1935.

Distribution is made only by the Superintendent of Documents, U.S. Government Printing Office, Washington, D.C. 20402.

The CODE OF FEDERAL REGULATIONS is sold by the Superintendent of Documents.

There are no restrictions on the republication of material appearing in the FEDERAL REGISTER or the CODE OF FEDERAL REGULATIONS.

HIGHLIGHTS—Continued

SOCIAL SECURITY —HEW proposal allowing birth certificate issued as result of adoption adequate evidence of adoption; comments by 12-12-71	21696	PESTICIDES — EPA notice establishing temporary tolerance for citrus fruit	21708
PIPELINE SAFETY —DOT withdrawal of proposal on corrosion pitting	21698	EPA notice of amended filing of petition regarding certain pesticide chemicals	21708
SAFETY AND INFORMATION GUIDES — AEC notice of new guides for design and evaluation of water cooled nuclear power plants	21707	ANTIDUMPING —Tariff Comm. notice of investigation and hearing on ice cream sandwich wafers from Canada	21715
AEC establishment of information guides to identify specific technical data for licensing review	21707	MINIMUM WAGES —Labor Dept. determination decision for Federal and federally assisted construction in specified localities; effective 11-12-71	21720

Contents

AGRICULTURE DEPARTMENT

See also Farmers Home Administration; Packers and Stockyards Administration.

Notices

Delegations of authority to appoint uniformed armed guards as special policemen: Administrator, Agricultural Research Service	21706
Director, Science and Education	21706
South Carolina; designation of areas for emergency loans	21706

ATOMIC ENERGY COMMISSION

Notices

Carolina Power & Light Co.; receipt of application for construction permits and facility licenses; time for submission of views on antitrust matters	21706
Information guides; notice of issuance	21707
Safety guides; notice of issuance	21707

CIVIL AERONAUTICS BOARD

Notices

Student, youth, and senior-citizen fares in foreign air transportation; prehearing conference	21716
---	-------

CIVIL SERVICE COMMISSION

Rules and Regulations

Excepted service: Department of Commerce	21665
Department of Justice	21665
Department of the Interior (2 documents)	21665
Export-Import Bank of the United States	21665
National Labor Relations Board	21665

Notices

Department of the Interior; revocation of authority to make non-career executive assignments (2 documents)	21707
Department of Transportation; grant of authority to make non-career executive assignment	21708

COMMERCE DEPARTMENT

See also Maritime Administration.

Notices

Children's sleepwear; standard; correction	21717
--	-------

COMPTROLLER OF THE CURRENCY

Notices

Bank of California, N.A.; application for unlisted trading privileges	21704
---	-------

EMPLOYMENT STANDARDS ADMINISTRATION

Notices

Minimum wage determinations for Federal and federally assisted construction; area wage determination decisions and modifications	21720
--	-------

ENVIRONMENTAL PROTECTION AGENCY

Notices

2-Ethylamino-4-isopropylamino-6-methylthio-s-triazine; establishment of temporary tolerance	21708
NACA Industry Task Force; filing of petition regarding pesticide chemical	21708

FARMERS HOME ADMINISTRATION

Rules and Regulations

Association loans and grants; community facilities, development, conservation, utilization; location of facilities in flood plain area (2 documents)	21666
--	-------

FEDERAL AVIATION ADMINISTRATION

Rules and Regulations

Area high routes; designation (2 documents)	21670, 21671
Beech airplanes; airworthiness directives (2 documents)	21668
Federal airway segments; alteration	21670
IFR altitudes; miscellaneous amendments	21671
Standard instrument approach procedures; miscellaneous amendments	21673
Transition areas: Alteration	21670
Designation	21670

Proposed Rule Making

Control zones and transition areas; alterations (3 documents)	21696, 21697
---	--------------

FEDERAL COMMUNICATIONS COMMISSION

Rules and Regulations

Spectrum management; land mobile allocations and assignments	21677
--	-------

(Continued on next page)

FEDERAL HOME LOAN BANK BOARD**Rules and Regulations**

Federal insurance reserve requirements and accounting for net income 21667

FEDERAL HOUSING ADMINISTRATION**Rules and Regulations**

Hospitals; inclusion of proprietary hospitals 21674

FEDERAL RESERVE SYSTEM**Rules and Regulations**

Bank holding companies; redesignation 21666

Notices

Bank holding companies; hearing regarding Rhode Island thrift institutions investments in commercial banks 21708

First Virginia Bankshares Corp.; orders approving acquisition of bank stock by bank holding company (2 documents) 21709

Old Colony Co-operative Bank; applications for approval to become registered bank holding company 21710

FISCAL SERVICE**Notices**

Accounts Bureau; statement of organization, functions and procedures 21704

FOOD AND DRUG ADMINISTRATION**Proposed Rule Making**

Manufacture and processing of canned foods; policy statement. 21688

GENERAL SERVICES ADMINISTRATION**Rules and Regulations**

Delegations of authority and selection and appointment of contracting officers' representatives 21676

GEOLOGICAL SURVEY**Notices**

Power site cancellations:
Cowlitz River, Wash. 21705
New Fork River Basin, Wyo. 21705

HEALTH, EDUCATION, AND WELFARE DEPARTMENT

See Food and Drug Administration; Public Health Service; Social Security Administration.

HOUSING AND URBAN DEVELOPMENT DEPARTMENT

See also Federal Housing Administration.

Notices

Deputy Regional Administrator et al., Region III (Philadelphia); designation to serve as Acting Regional Administrator 21707

INTERIOR DEPARTMENT

See Geological Survey; Land Management Bureau; National Park Service.

INTERNAL REVENUE SERVICE**Notices**

Appellate conferees; delegation of authority in protested cases and in tax court cases 21705

INTERSTATE COMMERCE COMMISSION**Proposed Rule Making**

Issuance of securities, assumption of obligations, and filing of certificates and reports; form of offering circular required for public sales of securities 21698

Notices

Assignment of hearings 21715
California Household Goods Carriers' Bureau; filing of application for agreement 21716

LABOR DEPARTMENT

See Employment Standards Administration; Occupational Safety and Health Administration.

LAND MANAGEMENT BUREAU**Rules and Regulations**

Special areas; sale of unintentional trespass lands 21677

MARITIME ADMINISTRATION**Notices**

Construction of liquefied natural gas vessels; computation of foreign cost; notice of intent; correction 21716
States Steamship Co.; application. 21716

NATIONAL PARK SERVICE**Rules and Regulations**

Bighorn Canyon National Recreation Area; designated airstrip. 21666

OCCUPATIONAL SAFETY AND HEALTH ADMINISTRATION**Proposed Rule Making**

Recording and reporting occupational injuries and illness; use of data-processing equipment; additional time for completing forms; posting of annual summary 21687

PACKERS AND STOCKYARDS ADMINISTRATION**Proposed Rule Making**

Live poultry; instructions on weighing and testing scales used in purchase, sale, or acquisition. 21683

PIPELINE SAFETY OFFICE**Proposed Rule Making**

Safety standards for gas pipelines; corrosion pitting 21698

PUBLIC HEALTH SERVICE**Proposed Rule Making**

Biological products; periodic check on sterile technique for whole blood (human) 21696

SECURITIES AND EXCHANGE COMMISSION**Notices***Hearings, etc.:*

Alabama Power Co. 21710
Butcher & Sherrerd 21711
East Ohio Gas Co. et al. 21712
New Bedford Gas and Edison Light Co. and Cape & Vineyard Electric Co. 21712
Ohio Power Co. and Captina Operating Co. 21713
Professional Retirement Equity Fund, Inc. 21714
Royal Atlas Corp. 21714
Sydnor-Barent Scanner Corp. 21715

SOCIAL SECURITY ADMINISTRATION**Proposed Rule Making**

Federal old-age, survivors, and disability insurance; evidence of adoption 21696

TARIFF COMMISSION**Notices**

Ice cream sandwich wafers from Canada; investigation and hearing 21715

TRANSPORTATION DEPARTMENT

See Federal Aviation Administration; Pipeline Safety Office.

TREASURY DEPARTMENT

See Comptroller of the Currency; Fiscal Service; Internal Revenue Service.

VETERANS ADMINISTRATION**Rules and Regulations**

Procurement by formal advertising and special types and methods of procurement 21676

List of CFR Parts Affected

The following numerical guide is a list of the parts of each title of the Code of Federal Regulations affected by documents published in today's issue. A cumulative list of parts affected, covering the current month to date, appears following the Notices section of each issue beginning with the second issue of the month.

A cumulative guide is published separately at the end of each month. The guide lists the parts and sections affected by documents published since January 1, 1971, and specifies how they are affected.

5 CFR		20 CFR		41 CFR	
213 (6 documents)	21665	PROPOSED RULES:		5A-1	21676
7 CFR		404	21696	8-2	21676
1823 (2 documents)	21666	21 CFR		8-4	21676
9 CFR		PROPOSED RULES:		42 CFR	
PROPOSED RULES:		3	21688	PROPOSED RULES:	
201	21683	24 CFR		73	21696
12 CFR		242	21674	43 CFR	
222	21666	29 CFR		2780	21677
225	21666	PROPOSED RULES:		47 CFR	
563	21667	1904	21687	1	21677
572	21667	36 CFR		21	21677
14 CFR		7	21666	74	21677
39 (2 documents)	21668			89	21677
71 (3 documents)	21670			91	21677
75 (2 documents)	21670, 21671			93	21677
95	21671			95	21677
97	21673			49 CFR	
PROPOSED RULES:				PROPOSED RULES:	
71 (3 documents)	21696, 21697			192	21698
				1115	21698

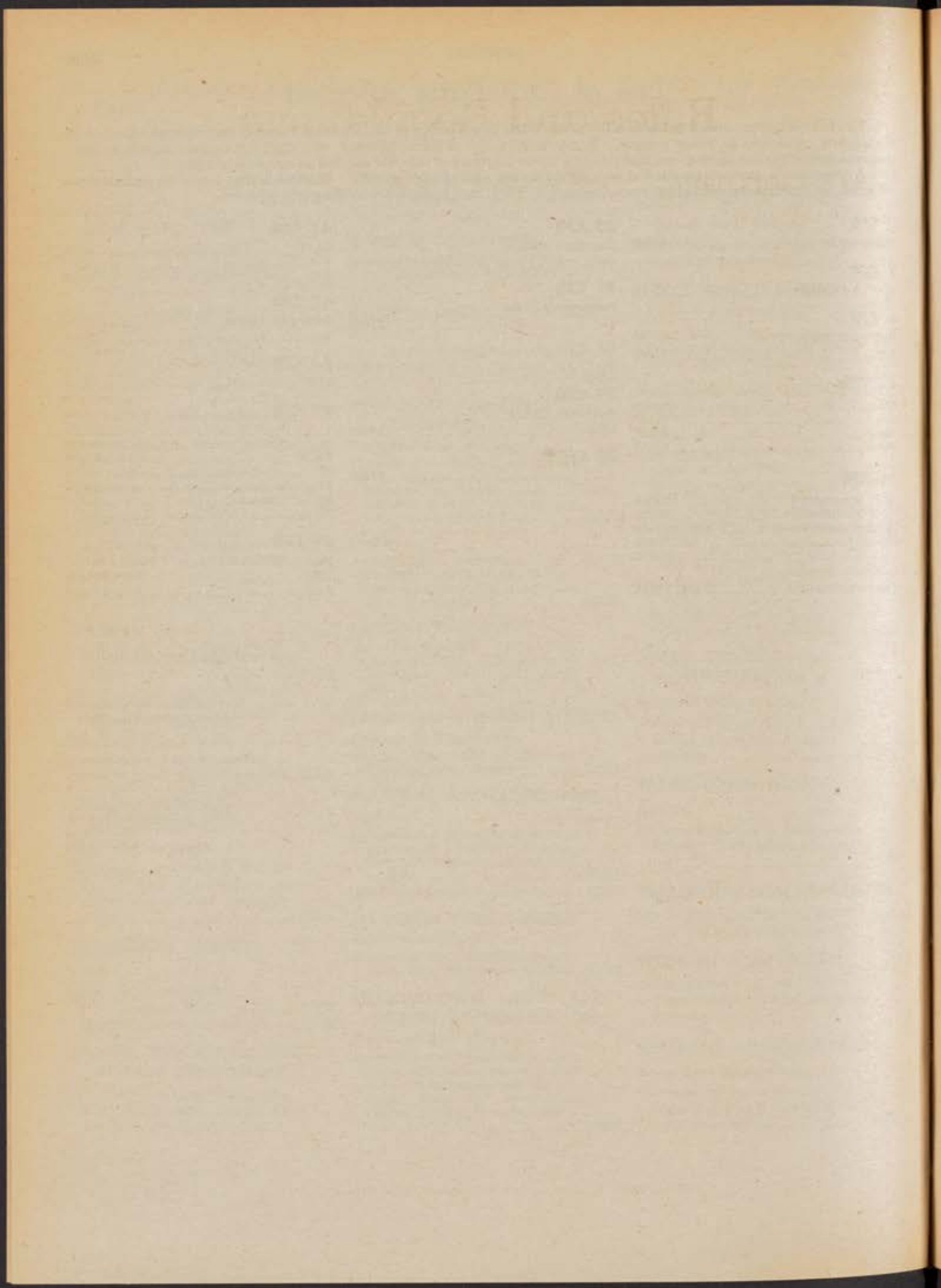

Rules and Regulations

Title 5—ADMINISTRATIVE PERSONNEL

Chapter I—Civil Service Commission

PART 213—EXCEPTED SERVICE

Department of Commerce

Section 213.3114 is amended to show that the positions of Security Control Officer, Deputy Security Control Officer, and Chief, Personnel Security Division, are no longer excepted under Schedule A.

Effective on publication in the FEDERAL REGISTER (11-12-71), subparagraph (1) of paragraph (b) of § 213.3114 is revoked.

§ 213.3114 Department of Commerce.

- (b) *Office of the Secretary.*
(1) [Revoked]

(5 U.S.C. secs. 3301, 3302, E.O. 10577; 3 CFR 1954-58 Comp. p. 218)

UNITED STATES CIVIL SERVICE COMMISSION,

[SEAL] JAMES C. SPRY,
*Executive Assistant to
the Commissioners.*

[FR Doc.71-16576 Filed 11-11-71;8:50 am]

PART 213—EXCEPTED SERVICE

Department of Justice

Section 213.3310 is amended to show that (1) two positions of Special Assistant to the Director, Community Relations Service, are excepted under Schedule C; (2) one position of Private Secretary to the Director, Community Relations Service, is no longer excepted under schedule; and (3) the title of the Private Secretary to the Special Assistant to the Director, Community Relations Service, has been changed to Private Secretary to the Special Assistant and Chief Counsel to the Director.

Effective on publication in the FEDERAL REGISTER (11-12-71), subparagraphs (1) and (3) are amended and subparagraph (5) is added to paragraph (r) of § 213.3310 as set out below.

§ 213.3310 Department of Justice.

- (r) *Community Relations Service.*
(1) One Private Secretary to the Director.

- (3) One Private Secretary to the Special Assistant and Chief Counsel to the Director.

(5) Two Special Assistants to the Director.

(5 U.S.C. secs. 3301, 3302, E.O. 10577; 3 CFR 1954-58 Comp. p. 218)

UNITED STATES CIVIL SERVICE COMMISSION,

[SEAL] JAMES C. SPRY,
*Executive Assistant to
the Commissioners.*

[FR Doc.71-16575 Filed 11-11-71;8:50 am]

PART 213—EXCEPTED SERVICE

Department of the Interior

Section 213.3312 is amended to show that one position of Confidential Assistant to the Assistant Secretary for Program Policy is excepted under Schedule C.

Effective on publication in the FEDERAL REGISTER (11-12-71), subparagraph (35) is added to paragraph (a) of § 213.3312 as set out below.

§ 213.3312 Department of the Interior.

- (a) *Office of the Secretary.* * * *
(35) One Confidential Assistant to the Assistant Secretary for Program Policy.

(5 U.S.C. secs. 3301, 3302, E.O. 10577; 3 CFR 1954-58 Comp. p. 218)

UNITED STATES CIVIL SERVICE COMMISSION,

[SEAL] JAMES C. SPRY,
*Executive Assistant to
the Commissioners.*

[FR Doc.71-16574 Filed 11-11-71;8:50 am]

PART 213—EXCEPTED SERVICE

Department of the Interior

Section 213.3312 is amended to show that one position of Associate Director for Programs, Bureau of Outdoor Recreation, is excepted under Schedule C. This section is further amended to show that the position of Special Assistant to the Director, Bureau of Outdoor Recreation, is no longer excepted under Schedule C.

Effective on publication in the FEDERAL REGISTER (11-12-71), subparagraph (3) is revoked and subparagraph (4) is added to paragraph (m) of § 213.3312 as set out below.

§ 213.3312 Department of the Interior.

- (m) *Bureau of Outdoor Recreation.* * * *

- (3) [Revoked]
(4) One Associate Director for Programs.

(5 U.S.C. secs. 3301, 3302, E.O. 10577; 3 CFR 1954-58 Comp. p. 218)

UNITED STATES CIVIL SERVICE COMMISSION,

[SEAL] JAMES C. SPRY,
*Executive Assistant to
the Commissioners.*

[FR Doc.71-16572 Filed 11-11-71;8:50 am]

PART 213—EXCEPTED SERVICE

National Labor Relations Board

Section 213.3341 is amended to show that the positions of Chief Counsel to the Chairman and Chief Counsel to a Board Member are no longer excepted under Schedule C.

Effective on publication in the FEDERAL REGISTER (11-12-71) paragraphs (f) and (g) are revoked under § 213.3341.

(5 U.S.C. secs. 3301, 3302, E.O. 10577; 3 CFR 1954-58 Comp. p. 218)

UNITED STATES CIVIL SERVICE COMMISSION,

[SEAL] JAMES C. SPRY,
*Executive Assistant to
the Commissioners.*

[FR Doc.71-16577 Filed 11-11-71;8:50 am]

PART 213—EXCEPTED SERVICE

Export-Import Bank of the United States

Section 213.3342 is amended to reflect the following title changes: from Private Secretary to the Executive Vice President to Confidential Assistant to the Executive Vice President and from Confidential Assistant to the Vice President for Export Expansion to Private Secretary to the Vice President for Export Expansion.

Effective on publication in the FEDERAL REGISTER (11-12-71) paragraphs (f) and (g) are amended under § 213.3342 as set out below.

§ 213.3342 Export-Import Bank of the United States.

- (f) One Private Secretary to the Vice President for Export Expansion.

- (g) One Confidential Assistant to the Executive Vice President.

(5 U.S.C. secs. 3301, 3302, E.O. 10577; 3 CFR 1954-58 Comp. p. 218)

UNITED STATES CIVIL SERVICE COMMISSION,

[SEAL] JAMES C. SPRY,
*Executive Assistant to
the Commissioners.*

[FR Doc.71-16573 Filed 11-11-71;8:50 am]

Title 7—AGRICULTURE

Chapter XVIII—Farmers Home Administration, Department of Agriculture

SUBCHAPTER B—LOANS AND GRANTS PRIMARYLY FOR REAL ESTATE PURPOSES

[FHA Instruction 442.1]

PART 1823—ASSOCIATION LOANS AND GRANTS—COMMUNITY FACILITIES, DEVELOPMENT, CONSERVATION, UTILIZATION

Subpart A—Loans and Grants for Community Domestic Water and Waste Disposal Systems

LOCATION OF FACILITIES IN FLOOD PLAIN AREA

Section 1823.19 is amended by adding a new paragraph (e) to implement the provisions of Executive Order 11296, dated August 10, 1966, regarding locating facilities in a flood plain area.

Subpart A of Part 1823, Title 7, Code of Federal Regulations (35 F.R. 15091), § 1823.19 as amended reads as follows:

§ 1823.19 Affect of special programs—regulations.

(e) *Location of facilities in flood plain area.* Executive Order 11296 dated August 10, 1966, requires that all executive agencies responsible for administration of Federal grant, loan, or mortgage insurance programs involving the construction of buildings, structures, and other facilities, evaluate flood hazards, and, as far as practicable, preclude the use of flood plains. In the event it is necessary to consider locating facilities in a flood plain area, the State Director, will evaluate the proposal from the standpoint of special design and additional initial cost as well as maintenance costs. Facilities may be located in flood plain areas only after a careful evaluation of the proposal by the State Director and a determination that flood damage will not likely occur. Normally, the Corps of Engineers or the Soil Conservation Service of the U.S. Department of Agriculture will be in a position to provide information concerning the likelihood of flooding and the possibility of damage to the proposed facility. The evaluation and determination will be recorded and made a part of the docket.

(Sec. 339, 75 Stat. 318, 7 U.S.C. 1989; Orders of Secretary of Agriculture, 29 F.R. 16210, 32 F.R. 6650; E.O. 11296, 31 F.R. 10663)

Dated: November 3, 1971.

JOSEPH HASPRAY,
Deputy Administrator,
Farmers Home Administration.

[FR Doc.71-16554 Filed 11-11-71;8:48 am]

[FHA Instruction 442.9]

PART 1823—ASSOCIATION LOANS AND GRANTS—COMMUNITY FACILITIES, DEVELOPMENT, CONSERVATION, UTILIZATION

Subpart I—Processing Loans to Associations (Except for Domestic Water and Waste Disposal)

LOCATION OF FACILITIES IN FLOOD PLAIN AREA

Section 1823.263 is amended by adding a new paragraph (d) to implement the provisions of Executive Order 11296, dated August 10, 1966, regarding locating facilities in a flood plain area.

Subpart I of Part 1823, Title 7, Code of Federal Regulations (35 F.R. 15091), § 1823.263 as amended reads as follows:

§ 1823.263 Affect of special programs—regulations.

(d) *Location of facilities in flood plain area.* Executive Order 11296, dated August 10, 1966, requires that all executive agencies responsible for administration of Federal grant, loan, or mortgage insurance programs involving the construction of buildings, structures, and other facilities, evaluate flood hazards, and, as far as practicable, preclude the use of flood plains. In the event it is necessary to consider locating facilities in a flood plain area, the State Director will evaluate the proposal from the standpoint of special design and additional initial cost as well as maintenance costs. Facilities may be located in flood plain areas only after a careful evaluation of the proposal by the State Director and a determination that flood damage will not likely occur. Normally, the Corps of Engineers or the Soil Conservation Service of the U.S. Department of Agriculture will be in a position to provide information concerning the likelihood of flooding and possibility of damage to the proposed facility. The evaluation and determination will be recorded and made a part of the docket.

(Sec. 339, 75 Stat. 318, 7 U.S.C. 1989; Orders of Secretary of Agriculture, 29 F.R. 16210, 32 F.R. 6650; E.O. 11296, 31 F.R. 10663)

Dated: November 3, 1971.

JOSEPH HASPRAY,
Deputy Administrator,
Farmers Home Administration.

[FR Doc.71-16553 Filed 11-11-71;8:48 am]

Title 36—PARKS, FORESTS, AND MEMORIALS

Chapter I—National Park Service, Department of the Interior

PART 7—SPECIAL REGULATIONS, AREAS OF THE NATIONAL PARK SYSTEM

Bighorn Canyon National Recreation Area; Designated Airstrip

Pursuant to the authority contained in section 3 of the Act of August 25, 1916

(39 Stat. 535, as amended; 16 U.S.C. 3), the Act of October 15, 1966 (80 Stat. 913, 16 U.S.C. 460b), 245 DM 1 (27 F.R. 6395) and National Park Service Order No. 21 (27 F.R. 7903), as amended, Part 7 of Title 36 of the Code of Federal Regulations is hereby amended to add § 7.92 as set forth below.

It is the policy of the Department of the Interior, whenever practicable, to afford the public an opportunity to participate in the rule making process. However, since this regulation relaxes restrictions on the public, comment thereon is deemed unnecessary and not in the public interest. The amendment will thus take effect immediately upon its publication in the FEDERAL REGISTER (11-12-71).

Section 7.92 is added as follows:

§ 7.92 Bighorn Canyon National Recreation Area.

(a) *Aircraft-designated airstrip.* (1) Fort Smith landing strip, located at approximate latitude 45°19' N., approximate longitude 107°55'41" W. in the S½S½SE¼ sec. 8, and the S½SW¼ SW¼ sec. 9, T. 6 S., R. 31 E., Montana Principal Meridian.

LAWRENCE C. HADLEY,
Assistant Director,
National Park Service.

[FR Doc.71-16541 Filed 11-11-71;8:47 am]

Title 12—BANKS AND BANKING

Chapter II—Federal Reserve System

SUBCHAPTER A—BOARD OF GOVERNORS OF THE FEDERAL RESERVE SYSTEM

[Reg. Y]

PART 222—BANK HOLDING COMPANIES

PART 225—BANK HOLDING COMPANIES

Miscellaneous Amendments

The Board of Governors has amended Part 22 (Regulation Y) extensively during 1971, to implement the provisions of the Bank Holding Company Act Amendments of 1970, and is now in the process of printing the amended regulation in its entirety. Copies of the newly printed Regulation Y will be available to the public on or about December 1, 1971. Requests for the regulation should be directed to Publications Services, Board of Governors of the Federal Reserve System, Washington, D.C. 20551.

In connection with the printing of the amended regulation the Board of Governors redesignates Part 222 as Part 225. Part 225, "Bank Holding Companies," will continue to be designated as Regulation Y. The redesignation of sections within Part 222 are as follows:

1. Sections 222.1 through 222.4 are redesignated as §§ 225.1 through 225.4.
2. Sections 222.5, 222.6, and 222.7 are combined and redesignated as § 225.5 and are amended to read as follows:

§ 225.5 Administration.

(a) *Effective date of registration.* The date of registration of a bank holding

company shall be the date on which its registration statement is filed with the Federal Reserve bank.

(b) *Reports and examinations.* Each bank holding company shall furnish to the Board in a form prescribed by the Board a report of the company's operations for the fiscal year in which it becomes a bank holding company, and for each fiscal year thereafter until it ceases to be a bank holding company. Each such annual report shall be filed with the Federal Reserve bank. Each bank holding company shall furnish to the Board additional information at such times as the Board may require. The Board may examine any bank holding company or any of its subsidiaries and the cost of any such examination shall be assessed against and paid by such bank holding company. As far as possible the Board will use reports of examinations made by the Comptroller of the Currency, the Federal Deposit Insurance Corporation, or the appropriate State bank supervisory authority.

3. The interpretations contained in Part 222 are hereby redesignated as follows: § 222.101 as § 225.101; § 222.102 as § 225.102; § 222.103 as § 225.103; § 222.104 as § 225.104; § 222.107 as § 225.107; § 222.109 as § 225.109; § 222.111 as § 225.111; § 222.112 as § 225.112; § 222.113 as § 225.113; § 222.115 as § 225.115; § 222.118 as § 225.118; § 222.121 as § 225.121; § 222.122 as § 225.122; and § 222.123 as § 225.123.

Effective date: December 1, 1971.

Board of Governors of the Federal Reserve System, November 5, 1971.

[SEAL] **TYNAN SMITH,**
Secretary of the Board.

[FR Doc.71-16537 Filed 11-11-71; 8:47 am]

Chapter V—Federal Home Loan Bank Board

SUBCHAPTER D—FEDERAL SAVINGS AND LOAN INSURANCE CORPORATION

[71-1174]

PART 563—OPERATIONS

PART 572—ACCOUNTING STATEMENTS OF POLICY

Federal Insurance Reserve Requirements and Accounting for Net Income

NOVEMBER 4, 1971.

Resolved that the Federal Home Loan Bank Board considers it advisable to amend Parts 563 and 572 of the rules and regulations for Insurance of Accounts (12 CFR Parts 563, 572) for the following purposes:

1. To provide that required transfers to the Federal insurance reserve account shall be computed by multiplying the applicable "bench mark" percentage by the average of an insured institution's savings account balances on the annual

closing date and on the two immediately preceding annual closing dates; and

2. To delete the definition of "net income" contained in § 563.14 of such regulations and to require reporting of net income in accordance with a new definition of such term which comports more closely with generally accepted accounting principles.

Accordingly, on the basis of such consideration and for such purposes, the Federal Home Loan Bank Board hereby amends said Parts 563 and 572 as follows, effective November 12, 1971:

1. Said Part 563 is amended as follows:
a. By revising paragraph (a)(1) of § 563.13 thereof to read as follows:

§ 563.13 Required amounts and maintenance of Federal insurance reserve.

(a) *Minimum reserve level.* (1) After the fiscal year in which a certificate of insurance is issued, an insured institution shall build up its Federal insurance reserve account so that, as of the close of business on the annual closing date following each anniversary of the date of insurance of accounts, such reserve account shall be at least equal to the amount obtained by multiplying (i) the average of the institution's savings account balances on such closing date and on the two immediately preceding annual closing dates by (ii) the percentage corresponding to such anniversary date, as set forth in the following table:

Anniversary	Percentage
2	0.50
3	0.75
4	1.00
5	1.25
6	1.50
7	1.75
8	2.00
9	2.25
10	2.50
11	2.75
12	3.00
13	3.25
14	3.50
15	3.75
16	4.00
17	4.25
18	4.50
19	4.75
20 and thereafter	5.00

b. By revising § 563.14 thereof to read as follows:

§ 563.14 Charging of losses and payment of dividends.

No insured institution which has charged losses to its Federal insurance reserve account shall declare any dividends or pay any interest on savings unless the amount standing to the credit of such account, after deduction of all charges, is equal to at least the amounts required under § 563.13: *Provided*, That, for any year dividends may be declared or interest on savings paid when losses are charged to such reserve, if the declaration of such dividends or the payment of such interest on savings is first approved by the Corporation: *And pro-*

vided further, That the Corporation hereby approves, for any such insured institution which has been insured for a period of 20 years or more and whose Federal insurance reserve account, prior to the charging of such losses, equaled at least 5 percent of all insured accounts, the declaration of dividends and the payment of interest on savings if such insured institution shall have first transferred not less than 25 percent of its net income for the same dividend period to its Federal insurance reserve account.

2. Said Part 572 is amended by adding a new § 572.3 thereto, to read as follows:

§ 572.3 Accounting for net income.

(a) *General.* Section 563.23-3 of this chapter provides that each insured institution shall employ such specific principles or procedures on particular accounting or reporting matters as the Corporation may require by regulation or otherwise. This statement specifies the Corporation's requirement with respect to the calculation and reporting of net income.

(b) *Definition of net income.* The term "net income" means gross income of all kinds from all sources less all expenses, including interest on Federal Home Loan Bank advances and borrowed money, interest or dividends on withdrawable or nonwithdrawable accounts (except capital stock), Federal, State, or local income taxes, if any, and losses of every kind and nature.

(c) *Reporting of net income.* All reports submitted to the Corporation by or for an insured institution (including reports of audit) which include therein data relating to net income for any quarterly period ending on or after October 31, 1971, shall report net income in accordance with the definition contained in paragraph (b) of this section.

(Secs. 402, 403, 48 Stat. 1256, 1257, as amended; 12 U.S.C. 1725, 1726. Reorg. Plan No. 3 of 1947, 12 F.R. 4981, 3 CFR, 1943-48 Comp., p. 1071)

Resolved further that, since affording notice and public procedure on the above amendments would delay them from becoming effective for a period of time and since it is in the public interest that such amendments become effective as soon as possible, the Board hereby finds that notice and public procedure thereon are contrary to the public interest under the provisions of 12 CFR 508.11 and 5 U.S.C. 553(b); and the Board also finds, for the same reason, that publication for the 30-day period specified in 12 CFR 508.14 and 5 U.S.C. 553(d) prior to the effective date of the amendments is unnecessary; and the Board hereby provides that the amendments shall become effective as hereinbefore set forth.

By the Federal Home Loan Bank Board.

[SEAL] **JACK CARTER,**
Secretary.

[FR Doc.71-16590 Filed 11-11-71; 8:51 am]

Title 14—AERONAUTICS AND SPACE

Chapter I—Federal Aviation Administration, Department of Transportation

[Docket No. 70-CE-21-AD; Amdt. 39-1832]

PART 39—AIRWORTHINESS DIRECTIVES

Beech Model 65-90 Airplanes

Amendment 39-1121, published in the FEDERAL REGISTER on December 4, 1970 (35 F.R. 18452, 18453), AD 70-25-4, applicable to Beech Model 65-90 airplanes is an Airworthiness Directive which requires repetitive inspection of specific wing components to detect cracks.

After issuing Amendment 39-1121, the agency determined that reference to paragraph E in paragraph A(1) of the AD is in error and should be deleted. In addition, the repetitive inspection interval required after a crack is found as specified in paragraph A(1) of the AD is being increased to 300 hours to provide relief for its operators with 75- to 100-hour inspection cycles. Clarification of the inspections required of the inboard and outboard wing attach fittings as specified in paragraphs B and D of the AD and correct call out of the four inspection holes in paragraph D(6) is necessary. Finally, paragraph F is being amended to permit operators to report information regarding cracks to the agency through normal M or D procedures. Accordingly, it is necessary to amend paragraphs A(1), B, D, and F of AD 70-25-4 to effect these changes.

Due to the many changes in AD 70-25-4 it is being amended and reissued in its entirety.

Since this amendment is in the interest of safety, corrects an error, provides clarification, relieves a reinspection cycle and imposes no additional burden on any person, notice and public procedure hereon are unnecessary and the amendment may be made effective in less than thirty (30) days.

In consideration of the foregoing, and pursuant to the authority delegated to me by the Administrator (31 F.R. 13697), § 39.13 of the Federal Aviation Regulations, Amendment 39-1121 (35 F.R. 18452, 18453), AD 70-25-4, is amended so that it now reads as follows:

BEECH. Applies to Model 65-90 (serial Nos. LJ-1 through LJ-67) airplanes with 5,000 or more hours' time in service.

Compliance: Required as indicated.

To detect any cracking of certain wing center section and other wing panel front spar carry through structural components, within the next 100 hours' time in service after December 5, 1970, unless already accomplished, accomplish the following:

(A) Visually inspect the lower wing skin area adjacent to each outer wing panel front spar attachment fitting for cracks in accordance with Beechcraft Service Instruction No. 0394-018 or later revision approved by the Chief, Engineering and Manufacturing Branch, FAA, Central Region, and thereafter

repeat the inspection at intervals not to exceed 100 hours' time in service.

(1) If wing panel skin cracks are found at the most outboard screw hole as noted in Figure 1 of Beechcraft Service Instruction No. 0394-018, the wing structure must be inspected in accordance with paragraphs B and D of this AD prior to returning the aircraft to service. In addition, if a skin crack is found at the most outboard screw hole, as indicated in said Figure 1, the paragraph B inspections must be performed at intervals of not more than 300 hours, and the paragraph D inspections must be performed at intervals of not more than 500 hours.

(B) Inspect by visual and dye penetrant methods, the right and left lower forward outboard wing attachment fittings for cracks in accordance with Beechcraft Service Instruction No. 0394-018 or later revision approved by the Chief, Engineering and Manufacturing Branch, FAA, Central Region, and thereafter repeat the inspection at intervals not to exceed 500 hours' time in service, except as noted in paragraph A(1).

(C) If fatigue cracks are found in either wing attach fitting during the inspections required by paragraph B, prior to further flight—

(1) Both right and left outer wing panel lower forward spar caps including the wing attachment fittings and the skin panels adjacent to the outer panel wing attachment fittings must be replaced with new parts in accordance with the procedures, limitations, and reinspection intervals specified in Beechcraft Service Instruction No. 0394-018, or later revision approved by the FAA.

(2) After one replacement of the assemblies listed in paragraph C(1), replace the wing center section lower forward spar cap and fittings with new parts in accordance with Beechcraft Service Instruction No. 0394-018, or later revision approved by the Chief, Engineering and Manufacturing Branch, FAA, Central Region.

(D) Inspect the structural components set forth below and in Beechcraft Service Instruction No. 0394-018, or later revision approved by the Chief, Engineering and Manufacturing Branch, FAA, Central Region, by visual, eddy current and dye penetrant methods, as specified in the service instructions, and thereafter repeat the inspection at intervals not to exceed 1,000 hours' time in service, except as noted in paragraphs A(1) and D(8). The structural components to be inspected are as follows:

(1) Right and left lower forward wing attachment fitting of the center section main spar.

(2) Lower forward wing fitting-to-spar attachment area and the edges of the forward and aft flanges on the lower forward spar cap in the center section (outboard of each main gear wheel well).

(3) Lower forward spar cap in each main gear wheel well.

(4) Lower surface of the lower forward spar cap in the nacelle inboard of each main gear wheel well.

(5) Lower surface of the lower forward spar cap between each nacelle and the fuselage.

(6) The four universal rivet holes in the forward flange of the lower forward spar cap inboard of each nacelle in the area of the wing root rib.

(7) The lower forward spar cap within the fuselage.

(8) The centerline skin splice in the area between the forward and aft center section spars, and the fuselage formers along the centerline between the forward and aft center section spars. If fuselage former cracks are found in this area, they must be repaired in accordance with said service instruction prior to return to service and the 1,000 hour inspection interval must be reduced to not more than 500 hours.

(E) If cracks are found during the inspections required by paragraph D, except cracks located in the areas specified in paragraph D(8), prior to further flight, replace the wing center section lower forward spar cap, both the right and left outer wing panel lower front spar caps including the wing attachment fittings and the skin panels adjacent to the outer panel wing attachment fittings with new production parts in accordance with Beechcraft Service Instruction No. 0394-018, or later revision approved by the Chief, Engineering and Manufacturing Branch, FAA, Central Region.

(F) Aircraft logbook entries must be made and notification in writing must be sent to Chief, Engineering and Manufacturing Branch, FAA, Central Region, of the location and length of any cracks found during inspections required by this AD and also the total time in service of the component at the time the crack was discovered. Malfunction or defect report, FAA Form 8330-2, may be used for this purpose. (Report approved by the Bureau of the Budget under BOB No. 04-R0174.)

(G) Replacement of parts required by paragraphs C and E will permit the owner/operator to establish new initial inspection times in compliance with paragraphs A and B.

(H) Equivalent methods of compliance with this AD must be approved by the Chief, Engineering and Manufacturing Branch, FAA, Central Region.

NOTE: The eddy current inspections required by this AD should be performed by certificated personnel trained and qualified in the operation of eddy current equipment. The replacement of critical parts such as the spar caps and wing attach fittings required by this AD should be performed by certificated personnel or facilities properly equipped to perform such repairs.

This amendment becomes effective November 16, 1971.

(Secs. 313(a), 601, 603, Federal Aviation Act of 1958, 49 U.S.C. 1354(a), 1421, 1423; sec. 6(c), Department of Transportation Act, 49 U.S.C. 1655(c))

Issued in Kansas City, Mo., on November 4, 1971.

JOHN M. CYROCKI,
Director, Central Region.

[FR Doc. 71-16496 Filed 11-11-71; 8:45 am]

[Docket No. 70-CE-20-AD; Amdt. 39-1831]

PART 39—AIRWORTHINESS DIRECTIVES

Beech Models 65, 65-80, 65-A80 and 65-B80 Airplanes

Amendment 39-1120, published in the FEDERAL REGISTER on December 4, 1970 (35 F.R. 18451, 18452), AD 70-25-1, applicable to Beech Models 65, 65-80, 65-A80 and 65-B80 airplanes, is an AD which requires repetitive inspection of specific wing components to detect fatigue cracks.

After issuing Amendment 39-1120, the agency determined that the repetitive inspection interval required after a crack is found as specified in paragraph A(1) of the AD may be increased to 300 hours to provide relief for its operators with 75 to 100 hour inspections. Clarification of the inspections required of the inboard and outboard wing attach

fittings as specified in paragraph B of the AD is also necessary. Additionally, reference to paragraphs D, E, and F in paragraph I is misplaced and must be corrected. Paragraph H is being amended to permit operators to report information regarding cracks to the agency through normal M or D procedures. Finally, a group of military aircraft serial numbers has been added to the applicability statement and to the applicable portions of AD paragraphs A, B, C(2), C(4), and D. Accordingly, it is necessary to amend the applicability statement and all alphabetically listed paragraphs of AD 70-25-1, with the exception of paragraphs E, F, and J.

Due to the many changes to AD 70-25-1, it is being amended and reissued in its entirety.

Since this amendment is in the interest of safety, corrects an error, provides clarification and is in part relaxatory in nature, it imposes no additional burden on any person. Consequently, notice and public procedure hereon are unnecessary and the amendment may be made effective in less than thirty (30) days.

In consideration of the foregoing, and pursuant to the authority delegated to me by the Administrator (31 F.R. 13697), § 39.13 of the Federal Aviation Regulations, Amendment 39-1120 (35 F.R. 18451, 18452), AD 70-25-1, is amended so that it now reads as follows:

Beech. Applies to Models 65 (Military U-8F) (serial Nos. L-1, L-2, L-6, LF-7 thru LF-76 and LC-1 thru LC-180) and 65-B80 (serial Nos. LD-270 and up) airplanes with 5,000 or more hours' time in service; and Models 65-80, 65-A80 (serial Nos. LD-1 thru LD-244) airplanes with 3,000 or more hours' time in service.

Compliance: Required as indicated.

To detect cracking of certain wing center section and other wing panel front spar carry through structural components, within the next 100 hours' time in service after December 5, 1970, except that Beech Model 65 (Military U-8F) serial Nos. LF-9 thru LF-76, commence compliance within the next 100 hours' time in service after the effective date of this amendment, unless already accomplished, accomplish the following:

(A) On Beech Models 65 (Military U-8F) (serial Nos. L-1, L-2, L-6, LF-7 through LF-76 and LC-1 through LC-180) and 65-B80 (serial Nos. LD-270 and up) airplanes with 5,000 or more hours' time in service, or upon accumulation of 5,000 hours' time in service; and Beech Models 65-80, 65-A80 (serial Nos. LD-1 through LD-244) airplanes with 3,000 or more hours' time in service or upon accumulation of 3,000 hours' time in service, and thereafter on all aircraft listed in this AD at intervals not to exceed 100 hours, visually inspect the lower wing skin area adjacent to each outer wing panel front spar attachment fitting for cracks in accordance with Beechcraft Service Instruction No. 0393-018 or later revision approved by the Chief, Engineering and Manufacturing Branch, FAA, Central Region.

(1) If wing panel skin cracks are found at the most outboard screw hole, as indicated in Figure 1 of Beechcraft Service Instruction No. 0393-018, the paragraphs B and F inspections must be performed thereafter at not more than 300-hour intervals, and paragraph D inspections must be performed thereafter at not more than 500-hour intervals.

(B) On Beech Models 65 (Military U-8F) (serial Nos. L-1, L-2, L-6, LF-7 through LF-76 and LC-1 through LC-180), 65-B80 (serial Nos. LD-270 and up) airplanes with 5,000 or more hours' time in service or upon accumulation of the first 5,000 hours' time in service, and Beech Models 65-80, 65-A80 (serial Nos. LD-1 through LD-244) airplanes with 3,000 or more hours' time in service, or upon accumulation of the first 3,000 hours' time in service, and thereafter on all aircraft listed in this AD, at intervals not to exceed 500 hours, except as noted in paragraph A(1), inspect by visual and dye penetrant methods, the right and left lower forward outboard wing attachment fittings for cracks in accordance with Beechcraft Service Instruction No. 0393-018 or later revision approved by the Chief, Engineering and Manufacturing Branch, FAA, Central Region.

(C) If fatigue cracks are found in either wing attach fitting during the inspections required by paragraph B, prior to further flight:

(1) On all aircraft, both right and left outer wing panel lower forward spar caps including the wing attachment fittings and the skin panels adjacent to the outer panel wing attachment fittings must be replaced with new parts in accordance with the procedures, limitations and reinspection intervals specified in Beechcraft Service Instruction No. 0393-018 or later revision approved by the Chief, Engineering and Manufacturing Branch, FAA, Central Region.

(2) On Beech Models 65 (Military U-8F) (serial Nos. L-1, L-2, L-6, LF-7 through LF-76 and LC-1 through LC-180), 65-80 and 65-A80 (serial Nos. LD-1 through LD-244) airplanes, the inspection intervals for the structural components specified in paragraph D must be reduced to 500 hours and,

(3) On Beech Models 65-B80 (serial Nos. LD-270 and up) airplanes the wing center section lower forward spar cap and fittings must be replaced with new parts in accordance with Beechcraft Service Instruction No. 0393-018 or later revision approved by the Chief, Engineering and Manufacturing Branch, FAA, Central Region.

(4) On Beech Models 65 (Military U-8F) (serial Nos. L-1, L-2, L-6, LF-7 through LF-76 and LC-1 through LC-180), 65-80 and 65-A80 (serial Nos. LD-1 through LD-244) airplanes, after one replacement of the assemblies listed in paragraph C(1), replace the wing center section lower forward spar cap and fittings with new parts in accordance with Beechcraft Service Instruction No. 0393-018 or later revision approved by the Chief, Engineering and Manufacturing Branch, FAA, Central Region.

(D) On Beech Model 65 (Military U-8F) (serial Nos. L-1, L-2, L-6, LF-7 through LF-76 and LC-1 through LC-180) airplanes with 5,000 or more hours' time in service or upon accumulation of the first 5,000 hours' time in service and thereafter at intervals not to exceed 1,000 hours, except as noted in paragraph A(1), inspect the structural components set forth below and in Beechcraft Service Instruction No. 0393-018 or later revision approved by the Chief, Engineering and Manufacturing Branch, FAA, Central Region, by visual, eddy current and dye penetrant methods, as specified in the service instruction. The structural components to be inspected are as follows:

(1) Right and left lower forward wing attachment fitting of the center section main spar.

(2) Lower forward wing fitting-to-spar attachment area and the edges of the forward and aft flanges on the lower forward spar cap in the center section (outboard of each main gear wheel well).

(3) Lower forward spar cap in each main gear wheel well.

(4) Lower surface of the lower forward spar cap in the nacelle inboard of each main gear wheel well.

(5) Lower surface of the lower forward spar cap between each nacelle and the fuselage.

(6) The two $\frac{3}{16}$ -inch rivet holes in the forward flange of the lower forward spar cap inboard of each nacelle in the area of the wing root rib.

(7) The lower forward spar cap within the fuselage.

(8) The centerline skin splice in the area between the forward and aft center section spars, and the fuselage bulkhead along the centerline between the forward and aft center section spars. If fuselage bulkhead cracks are found in this area, they must be repaired in accordance with said service instruction prior to return to service.

(E) On Beech Models 65-80, 65-A80 (serial Nos. LD-1 through LD-244) airplanes with 3,000 or more hours' time in service or upon accumulation of the first 3,000 hours' time in service and thereafter at intervals not to exceed 1,000 hours except as noted in paragraph A(1), inspect the structural components as required in paragraph D.

(F) On Beech Model 65-B80 (serial Nos. LD-270 and up) airplanes with 5,000 or more hours' time in service or upon accumulation of the first 5,000 hours' time in service and thereafter at intervals not to exceed 500 hours, except as noted in paragraph A(1), inspect the structural components as required in paragraph D.

(G) If cracks are found during the inspections required by paragraphs D, E, and F above, except cracks located in the areas specified in paragraph D(8), prior to further flight, replace the wing center section lower forward spar cap including wing attachment fittings, both the right and left outer wing panel lower forward spar caps including the wing attachment fittings and the skin panels adjacent to the outer panel wing attachment fittings with new production parts in accordance with Beechcraft Service Instruction No. 0393-018 or later revision approved by the Chief, Engineering and Manufacturing Branch, FAA, Central Region.

(H) Aircraft logbook entries must be made and notification in writing must be sent to Chief, Engineering and Manufacturing Branch, FAA, Central Region, or the location and length of any cracks found during inspections required by this AD and also the total time in service of the components at the time the crack was discovered. Malfunction or defect report, FAA Form 8330-2, may be used for this purpose. (Report approved by the Bureau of the Budget under BOB No. 04-E0174.)

(I) On all aircraft, regardless of time in service, replacement of parts required by paragraphs C and G will permit the owner/operator to establish new initial inspection time in compliance with paragraphs A, B, D, E, and F.

(J) Equivalent methods of compliance with this AD must be approved by the Chief, Engineering and Manufacturing Branch, FAA, Central Region.

NOTE: The eddy current inspections required by this AD should be performed by certificated personnel trained and qualified in the operation of eddy current equipment. The replacement of critical parts such as the spar caps and wing attach fittings required by this AD should be performed by certificated personnel or facilities properly equipped to perform such repairs.

This amendment becomes effective November 16, 1971.

(Secs. 313(a), 601, 603, Federal Aviation Act of 1958, 49 U.S.C. 1354(a), 1421, 1423; sec.

6(c), Department of Transportation Act, 49 U.S.C. 1655(c))

Issued in Kansas City, Mo., on November 4, 1971.

JOHN M. CYROCKI,
Director, Central Region.

[FR Doc.71-16522 Filed 11-11-71;8:45 am]

[Airspace Docket No. 71-CE-14]

PART 71—DESIGNATION OF FEDERAL AIRWAYS, AREA LOW ROUTES, CONTROLLED AIRSPACE, AND REPORTING POINTS

Alteration of Transition Area

On September 10, 1971, a notice of proposed rule making was published in the FEDERAL REGISTER (36 F.R. 18214) stating that the Federal Aviation Administration (FAA) was considering an amendment to Part 71 of the Federal Aviation Regulations that would amend the Roseau, Minn., transition area.

Interested persons were afforded an opportunity to participate in the proposed rule making through the submission of comments. The only comment received offered no objection.

A small portion of airspace east of the airport was inadvertently omitted in the transition area description published in the notice of proposed rule making. Action to correct this oversight is taken herein. Since this amendment is minor in nature and no substantive change in regulation is effected, notice and public procedure thereon are unnecessary.

In consideration of the foregoing, Part 71 of the Federal Aviation Regulations is amended, effective 0901 G.m.t., January 6, 1972, as hereinafter set forth.

In § 71.181 (36 F.R. 2140) the Roseau, Minn., transition area is amended to read:

That airspace extending upward from 700 feet above the surface within a 5-mile radius of Roseau Municipal Airport (lat. 48°51'25" N., long. 95°41'40" W.); within 2½ miles each side of the 163° bearing from Roseau Municipal Airport, extending from the 5-mile radius area to 7 miles south of the airport; and within 2½ miles each side of the 341° bearing from Roseau Municipal Airport, extending from the 5-mile radius area to 7 miles north of the airport; and that airspace extending upward from 1,200 feet above the surface within 4½ miles west and 9½ miles east of the 163° bearing from Roseau Municipal Airport, extending from the airport to 18½ miles south of the airport; and within 4½ miles west and 9½ miles east of the 341° bearing from Roseau Municipal Airport, extending from the airport to 18½ miles north of the airport, including that airspace east of and within a 9½ mile radius of the airport between the 71° and 73° bearings from the airport, and excluding the portions outside the United States.

(Sec. 307(a), Federal Aviation Act of 1958, 49 U.S.C. 1348(a); sec. 6(c), Department of Transportation Act, 49 U.S.C. 1655(c))

Issued in Washington, D.C., on November 5, 1971.

T. McCORMACK,
Acting Chief, Airspace and
Air Traffic Rules Division.

[FR Doc.71-16523 Filed 11-11-71;8:45 am]

[Airspace Docket No. 71-SO-129]

PART 71—DESIGNATION OF FEDERAL AIRWAYS, AREA LOW ROUTES, CONTROLLED AIRSPACE, AND REPORTING POINTS

Alteration of Federal Airway Segments

On August 11, 1971, a notice of proposed rule making was published in the FEDERAL REGISTER (36 F.R. 14763) stating that the Federal Aviation Administration (FAA) was considering an amendment to Part 71 of the Federal Aviation Regulations that would alter segments of VOR Federal airways V-39, V-56, and V-296.

Interested persons were afforded an opportunity to participate in the proposed rule making through the submission of comments. Comments received were favorable except for the U.S. Air Force's objection to the proposed alteration of V-39. Although the Seymour Johnson AFB aerobatic maneuver area has been relocated, that airspace overlying V-39 between Myrtle Beach, S.C., and Fayetteville, N.C., is continuously required for Myrtle Beach AFB fighter aircraft aerobatic and formation maneuvers. In view of this, the current maximum authorized altitude restriction on V-39 between Myrtle Beach, S.C., and Fayetteville, N.C., will be retained.

In consideration of the foregoing, Part 71 of the Federal Aviation Regulations is amended, effective 0901 G.m.t., January 6, 1972, as hereinafter set forth.

1. In § 71.123 (36 F.R. 2010 and 18076) V-56 is amended by deleting "The airspace at and above 5,000 feet MSL is excluded from Fayetteville to Wallace INT; and the airspace at and above 9,000 feet MSL is excluded from Wallace INT to New Bern."

2. In § 71.123 (36 F.R. 2010 and 11905) V-296 is amended by deleting "The airspace at and above 5,000 feet MSL is excluded from Fayetteville to Wilmington."

(Sec. 307(a), Federal Aviation Act of 1958, 49 U.S.C. 1348(a); sec. 6(c), Department of Transportation Act, 49 U.S.C. 1655(c))

Issued in Washington, D.C., on November 5, 1971.

T. McCORMACK,
Acting Chief, Airspace and
Air Traffic Rules Division.

[FR Doc.71-16524 Filed 11-11-71;8:46 am]

[Airspace Docket No. 71-CE-98]

PART 71—DESIGNATION OF FEDERAL AIRWAYS, AREA LOW ROUTES, CONTROLLED AIRSPACE, AND REPORTING POINTS

Designation of Transition Area

On page 17654 of the FEDERAL REGISTER dated September 3, 1971, the FAA published a notice of proposed rule making which would amend § 71.181 of the Federal Aviation Regulations so as to designate a transition area at Xenia, Ohio.

Interested persons were given 45 days to submit written comments, objections, or views concerning the proposed amendment. Two comments were received. The Air Transport Association offered no objections to the proposal. The United States Parachute Association, Mid-Eastern Conference objected to the proposal because it would interfere with parachute jumping operations conducted by the Greene County Sport Parachute Center, Inc., at Port Xenia, Xenia, Ohio. Subsequent to the issuance of this proposal an agreement was reached by representatives of the Dayton RAPCON, the controlling facility for the Xenia, Ohio, area and the Greene County Sport Parachute Center, Inc., which will permit both IFR operations and parachute jumping operations to be safely conducted. Since the parachutist's concern has been satisfied, the proposed amendment is hereby adopted without change and is set forth below.

This amendment shall be effective 0901 G.m.t., January 6, 1972.

(Sec. 307(a), Federal Aviation Act of 1958, 49 U.S.C. 1348; sec. 6(c), Department of Transportation Act, 49 U.S.C. 1655(c))

Issued in Kansas City, Mo., on November 1, 1971.

JOHN M. CYROCKI,
Director, Central Region.

In § 71.181 (36 F.R. 2140), the following transition area is added:

XENIA, OHIO

That airspace extending upward from 700 feet above the surface within a 5.5-mile radius of the Greene County Airport (latitude 39°41'30" N., longitude 83°59'25" W.); and within 3.5 miles each side of the 063° bearing from the Greene County Airport extending from the 5.5-mile radius to 14.5 miles northeast of the airport excluding that airspace that overlies the Dayton, Ohio transition area.

[FR Doc.71-16525 Filed 11-11-71;8:46 am]

[Airspace Docket No. 70-WA-42]

PART 75—ESTABLISHMENT OF JET ROUTES AND AREA HIGH ROUTES

Designation of Area High Routes

On June 19, 1971, F.R. Doc. 71-8675 was published in the FEDERAL REGISTER (36 F.R. 11807) which amends Part 75 of the Federal Aviation Regulations, effective 0901 G.m.t., August 19, 1971, by adding area high routes J813R, J814R, and J816R. Route alignments and waypoints from New Orleans, La., up to Montgomery, Ala., are identical on routes J813R and J814R. At Montgomery, Ala., a small turn is involved concerning J813R and the two routes diverge at that point. Due to the turn involved, the "Montgomery" waypoint was designated on J813R only. However, to reduce charting complexity and preclude possible pilot misunderstanding, the "Montgomery" waypoint should apply to both routes involved. Therefore, action is taken herein to designate the "Montgomery" waypoint on J814R.

Since this amendment is minor in nature and no substantive change in the regulation is effected, notice and public procedure thereon are unnecessary, and good cause exists for making this amendment effective on less than 30 days' notice.

In consideration of the foregoing, effective upon publication in the FEDERAL REGISTER (11-12-71), F.R. Doc. 71-8675 (36 F.R. 11807) is amended as herein-after set forth:

In J814R add new waypoint "Montgomery, Ala.," at Lat. "32°13'20" Long. "86°19'11" and Reference Facility "Montgomery, Ala.," between existing waypoints "Monroeville, Ala.," and "Texas, Ga."

(Sec. 307(a), Federal Aviation Act of 1958, 49 U.S.C. 1348(a); sec. 6(c), Department of Transportation Act, 49 U.S.C. 1655(c))

Issued in Washington, D.C., on November 5, 1971.

T. McCORMACK,
Acting Chief, Airspace and
Air Traffic Rules Division.

[FR Doc.71-16526 Filed 11-11-71;8:46 am]

[Airspace Docket No. 70-EA-73]

PART 75—ESTABLISHMENT OF JET ROUTES AND AREA HIGH ROUTES

Designation of Area High Routes

On September 17, 1971, F.R. Doc. 71-13615 was published in the FEDERAL REGISTER (36 F.R. 18575) which amends Part 75 of the Federal Aviation regulations, effective 0901 G.m.t., November 11, 1971, by adding area high route J810R between O'Hare Airport at Chicago, Ill., and La Guardia Airport at New York City. Due to route variations applied in terminal area departure handling, from flight to flight, it is more practical to begin J810R at the Kinderhook, Mich., waypoint. Therefore, action is taken herein to delete the O'Hare, Ill., waypoint and that portion of the J810R route to the succeeding waypoint.

Since this amendment is minor in nature and no substantive change in the regulation is effected, notice and public procedure thereon are unnecessary, and good cause exists for making this amendment effective on less than 30 days' notice.

In consideration of the foregoing, effective upon publication in the FEDERAL REGISTER, F.R. Doc. 71-13615 (36 F.R. 18575) is amended as hereinafter set forth.

In J810R, delete waypoint "O'Hare, Ill.," and Lat. "41°58'58" Long. "87°53'55" and Reference Facility "Pullman, Mich."

(Sec. 307(a), Federal Aviation Act of 1958, 49 U.S.C. 1348(a); sec. 6(c), Department of Transportation Act, 49 U.S.C. 1655(c))

Issued in Washington, D.C., on November 5, 1971.

T. McCORMACK,
Acting Chief, Airspace and
Air Traffic Rules Division.

[FR Doc.71-16527 Filed 11-11-71;8:46 am]

[Reg. Docket No. 11477; Amdt. 95-213]

PART 95—IFR ALTITUDES

Miscellaneous Amendments

The purpose of this amendment to Part 95 of the Federal Aviation regulations is to make changes in the IFR altitudes at which all aircraft shall be flown over a specified route or portion thereof. These altitudes, when used in conjunction with the current changeover points for the routes or portions thereof, also assure navigational coverage that is adequate and free of frequency interference for that route or portion thereof.

As a situation exists which demands immediate action in the interest of safety, I find that compliance with the notice and procedure provisions of the Administrative Procedure Act is impracticable and that good cause exists for making this amendment effective within less than 30 days from publication.

In consideration of the foregoing and pursuant to the authority delegated to me by the Administrator (24 F.R. 5662), Part 95 of the Federal Aviation regulations is amended, effective December 9, 1971, as follows:

1. By amending Subpart C as follows:

From, to, and MEA

Section 95.101 *Amber Federal airway 1* is amended to read in part:

McGrath, Alaska, LFR; Unalakleet, Alaska, LFR; *6,000. *5,800—MOCA.
Unalakleet, Alaska, LFR; Darby INT, Alaska; *3,000. *2,800—MOCA.

Section 95.115 *Amber Federal airway 15* is amended to read in part:

Sagwon, Alaska, LF/RBN; Deadhorse, Alaska, LF/RBN; 3,000.

Section 95.47 *Green Federal airway 7* is amended to read in part:

Nome, Alaska, LFR; Norton Bay, Alaska, LF/RBN; *5,000. *4,200—MOCA.
Norton Bay, Alaska, LF/RBN; Koyuk INT, Alaska; 4,000.
Birch INT, Alaska; Nenabank INT, Alaska; 4,100.
Nenabank INT, Alaska; Fairbanks, Alaska, LFR; 4,100.

Section 95.240; *Red Federal airway 40* is amended to read in part:

Skilak INT, Alaska; Anchorage, Alaska, LFR; 2,500.

Section 95.1001 *Direct routes—United States* is amended to delete:

Fort Lauderdale, Fla., VOR; New River INT, Fla.; *1,500. *1,400—MOCA.
Miami, Fla., VOR; Plantation, Fla., LF/RBN; *1,500. *1,400—MOCA.
Miami, Fla., VOR; Fort Lauderdale, Fla., VOR; 2,000.
Plantation, Fla., LF/RBN; New River INT, Fla.; *1,500. *1,400—MOCA.
Flaxman, Alaska, NDB; Barter Island, Alaska, NDB; *2,000. *1,200—MOCA.
Fort Yukon, Alaska, VOR; Flaxman Island, Alaska LF/RBN; † 12,000.
NDB; *2,000. *1,300—MOCA.

† MEA is established with a gap in navigation signal coverage.
Oliktok, Alaska, NDB; Flaxman, Alaska,

Section 95.1001 *Direct routes—United States* is amended by adding:

From, to, and MEA

Deadhorse, Alaska, LF/RBN; Barter Island, Alaska, LF/RBN; *2,000. *1,200—MOCA.

From/to; total distance; changeover point; distance, from, geographic location; track angle; MEA; and MAA

J803R is amended to read in part:
Mina, Nev., W/P, Bristol, Nev., W/P; 157.4; 30.0, Mina, 38°43'41" N., 117°25'42" W.; 54°/234° to COP, 57°/237° to Bristol; 18,000; 45,000.

J824R is added to read:
Jerseyville, Ill., W/P, Kappa, Ill., W/P; 124.3; 62.1, Jerseyville, 39°57'23" N., 89°36'51" W.; 028°/208° to COP, 027°/207° to Kappa; 18,000; 45,000.

Kappa, Ill., W/P, Joliet, Ill., VORTAC; 50.0; 00.0, Kappa, 40°50'22" N., 88°54'07" W.; 030°/210° to Joliet; 18,000; 45,000.

Joliet, Ill., VORTAC, Warren, Ill., W/P; 16.0; 006°/186° to Warren; 18,000; 45,000.

J882R is amended to read in part:
Calumet, Ky., W/P, Carlos, Ohio, W/P; 115.7; 57.8, Calumet, 39°03'04" N., 84°25'5" W.; 000°/180° to COP, 001°/181° to Carlos; 18,000; 45,000.

Carlos, Ohio, W/P, Milan, Mich., W/P; 125.4; 013°/193° to Milan; 18,000; 45,000.

Section 95.6006 *VOR Federal airway 6* is amended to read in part:

Wellman INT, Iowa; Iowa City, Iowa, VOR; *2,400. *1,900—MOCA.

Touhy INT, Nebr.; Yutan INT, Nebr.; *3,000. *2,600—MOCA.

Yutan INT, Nebr.; Richfield INT, Nebr.; 3,000.

Section 95.6008 *VOR Federal airway 8* is amended to read in part:

Touhy INT, Nebr.; Yutan INT, Nebr.; *3,000. *2,600—MOCA.

Yutan INT, Nebr.; Richfield INT, Nebr.; 3,000.

Wellman INT, Iowa; Iowa City, Iowa, VOR; *2,400. *1,900—MOCA.

Section 95.6012 *VOR Federal airway 12* is amended to read in part:

Zuni, N. Mex., VOR; *McCarty INT, N. Mex.; **11,000. *10,000—MCA McCarty INT, westbound. **10,700—MOCA.

McCarty INT, N. Mex.; *Albuquerque, N. Mex., VOR; 9,000. *10,700—MCA Albuquerque VOR, eastbound.

Zuni, N. Mex., VOR via S alter.; Acoma INT, N. Mex., via S alter.; *11,500. *10,800—MOCA.

Acoma INT, N. Mex., via S alter.; Lava INT, N. Mex., via S alter.; 9,000.

Lava INT, N. Mex., via S alter.; Albuquerque, N. Mex., VOR via S alter.; *9,000. *8,400—MOCA.

Section 95.6014 *VOR Federal airway 14* is amended to read in part:

Fallis INT, Okla.; Tulsa, Okla., VOR; *3,000. *2,500—MOCA.

Section 95.6015 *VOR Federal airway 15* is amended to read in part:

Humble, Tex., VOR, via E alter.; Whitehall INT, Tex., via E alter.; 1,700.

Whitehall INT, Tex., via E alter.; Navasota, Tex., VOR, via E alter.; *1,900. *1,600—MOCA.

Section 95.6018 *VOR Federal airway 18* is amended to read in part:

Hokes Bluff INT, Ala., via N alter.; Rome, Ga., VOR, via N alter.; 5,000.

Section 95.6020 *VOR Federal airway 20* is amended to read in part:

From, to, and MEA

Gibson INT, Ala., via N alter.; Felton INT, Ala., via N alter.; *6,000. *3,400—MOCA.
Felton INT, Ala., via N alter.; Gore INT, Ala., via N alter.; *5,000. *4,000—MOCA.
Gore INT, Ala., via N alter.; Rome, Ga., VOR, via N alter.; 5,000.
Palacios, Tex., VORTAC; Markham INT, Tex.; 1,500.
Markham INT, Tex.; Key INT, Tex.; *1,800. *1,400—MOCA.

Section 95.6021 *VOR Federal airway 21* is amended to read in part:

Salt Lake City, Utah, VOR; Ogden, Utah, VOR; 7,000.

Section 95.6033 *VOR Federal airway 33* is amended to read in part:

Greenpark INT, Pa.; Walnut INT, Pa.; *4,000. *3,700—MOCA.
Walnut INT, Pa.; Reedsville INT, Pa.; *4,000. *3,400—MOCA.
Reedsville INT, Pa.; Philipsburg, Pa., VOR; *4,000. *3,900—MOCA.

Section 95.6035 *VOR Federal airway 35* is amended to read in part:

Macon, Ga., VOR; Sinclair INT, Ga.; *2,500. *2,200—MOCA.
Sinclair INT, Ga.; Madison INT, Ga.; *2,500. *2,000—MOCA.
Madison INT, Ga.; Athens, Ga., VOR; *2,500. *2,300—MOCA.

Section 95.6036 *VOR Federal airway 36* is amended to read in part:

Lake Henry, Pa., VOR; Pecks Pond INT, Pa.; *4,000. *3,800—MOCA.

Section 95.6067 *VOR Federal airway 67* is amended to delete:

Waterloo, Iowa, VOR; *Shell Rock INT, Iowa; **2,600. *3,500—MRA. **2,300—MOCA.
Shell Rock INT, Iowa; *Aredale INT, Iowa; **2,800. *3,500—MRA. **2,300—MOCA.
Aredale INT, Iowa; Mason City, Iowa, VOR; *2,900. *2,500—MOCA.
Mason City, Iowa, VOR; Rochester, Minn., VOR; *3,000. *2,600—MOCA.
Mason City, Iowa, VOR via W alter.; Oakland INT, Minn., via W alter.; 3,000.
Oakland INT, Minn., via W alter.; Rochester, Minn., VOR via W alter.; *3,000. *2,700—MOCA.

Section 95.6067 *VOR Federal airway 67* is amended by adding:

Waterloo, Iowa, VOR; Waverly INT, Iowa; *2,800. *2,300—MOCA.
Waverly INT, Iowa; New Hampton INT, Iowa; *2,800. *2,300—MOCA.
New Hampton INT, Iowa; Rochester, Minn., VOR; *3,000. *2,700—MOCA.

Section 95.6077 *VOR Federal airway 77* is amended by adding:

Des Moines, Iowa, VOR; *Mitchellville INT, Iowa; 2,700. *4,000—MRA.
Mitchellville INT, Iowa; Newton, Iowa, VOR; 2,700.
Newton, Iowa, VOR; Dunbar INT, Iowa; *2,800. *2,300—MOCA.
Dunbar INT, Iowa; *Reinbeck INT, Iowa; **2,800. *2,700—MRA. **2,300—MOCA.
Reinbeck INT, Iowa; Waterloo, Iowa, VOR; *2,500. *2,300—MOCA.

See footnotes at end of document.

Section 95.6101 *VOR Federal airway 101* is amended to read in part:

From, to, and MEA

*Salt Lake City, Utah, VOR; Ogden, Utah, VOR; 7,000. *11,000—MCA Salt Lake City VOR, eastbound.

Section 95.6108 *VOR Federal airway 108* is amended to read in part:

Kettle INT, Colo.; Rush INT, Colo.; 9,000.
Rush INT, Colo.; Hugo, Colo., VOR; 9,000.
Hanover INT, Colo., via S alter.; Hugo, Colo., VOR via S alter.; 8,000.
Hugo, Colo., VOR; Goodland, Kans., VOR; *7,000. *6,200—MOCA.

Section 95.6120 *VOR Federal airway 120* is amended by adding:

Mason City, Iowa, VOR; *Aredale INT, Iowa; **2,900. *3,500—MRA. **2,500—MOCA.
Aredale INT, Iowa; *Shell Rock INT, Iowa; **2,800. *3,500—MRA. **2,300—MOCA.
Shell Rock INT, Iowa; Waterloo, Iowa, VOR; *2,600. *2,300—MOCA.

Section 95.6128 *VOR Federal airway 128* is amended to read in part:

Crown City INT, Ohio; Milton INT, W. Va.; 3,100.
Milton INT, W. Va.; Charleston, W. Va., VOR; 3,000.

Section 95.6153 *VOR Federal airway 153* is amended to read in part:

Stillwater, N.J., VOR; Pecks Pond INT, Pa.; *4,000. *3,100—MOCA.
Pecks Pond INT, Pa.; Lake Henry, Pa., VOR; *4,000. *3,800—MOCA.
Lake Henry, Pa., VOR; Hancock, N.Y., VOR; *4,400. *4,200—MOCA.

Section 95.6161 *VOR Federal airway 161* is amended to delete:

Des Moines, Iowa, VOR; *Mitchellville INT, Iowa; 2,700. *4,000—MRA.
Mitchellville INT, Iowa; Newton, Iowa, VOR; 2,700.
Newton, Iowa, VOR; Dunbar INT, Iowa; *2,800. *2,300—MOCA.
Dunbar INT, Iowa; *Reinbeck INT, Iowa; **2,800. *2,700—MRA. **2,400—MOCA.
Reinbeck INT, Iowa; Waterloo, Iowa, VOR; *2,500. *2,300—MOCA.
Waterloo, Iowa, VOR; Waverly INT, Iowa; *2,800. *2,300—MOCA.
Waverly INT, Iowa; New Hampton INT, Iowa; *2,800. *2,300—MOCA.
New Hampton INT, Iowa; Rochester, Minn., VOR; *3,000. *2,700—MOCA.

Section 95.6161 *VOR Federal airway 161* is amended by adding:

Des Moines, Iowa, VOR; Ankeny INT, Iowa; 2,500.
Ankeny INT, Iowa; Nevada INT, Iowa; 4,000.
Nevada INT, Iowa; Mason City, Iowa, VOR; *3,000. *2,500—MOCA.
Mason City, Iowa, VOR; Rochester, Minn., VOR; *3,000. *2,600—MOCA.
Mason City, Iowa, VOR via W alter.; Oakland INT, Minn., via W alter.; 3,000.
Oakland INT, Minn., via W alter.; Rochester, Minn., VOR via W alter.; *3,000. *2,700—MOCA.

Section 95.6169 *VOR Federal airway 169* is amended to read in part:

Tobe, Colo.; VOR; Hugo, Colo., VOR; *8,000. *7,700—MOCA.

Section 95.6184 *VOR Federal airway 184* is amended to read in part:

From, to, and MEA

Philipsburg, Pa., VOR; Reedsville INT, Pa.; *4,000. *3,900—MOCA.
Reedsville INT, Pa.; Walnut INT, Pa.; *4,000. *3,400—MOCA.
Walnut INT, Pa.; Greenpark INT, Pa.; *4,000. *3,700—MOCA.
Harrisburg, Pa., VOR; Delroy INT, Pa.; *3,000. *2,900—MOCA.
Paradise INT, Pa.; Modena, Pa., VOR; *2,500. *2,400—MOCA.

Section 95.6190 *VOR Federal airway 190* is amended to read in part:

St. Johns, Ariz., VOR; Acoma INT, N. Mex.; *11,500. *10,800—MOCA.
Acoma INT, N. Mex.; Lava INT, N. Mex.; 9,000.
Lava INT, N. Mex.; *Albuquerque, N. Mex., VOR; **9,000. *11,500—MCA Albuquerque VOR, northeastbound. **8,400—MOCA.
St. Johns, Ariz., VOR via S alter.; Stony INT, N. Mex., via S alter.; *12,000. *11,100—MOCA.
Stony INT, N. Mex., via S alter.; Albuquerque, N. Mex., VOR via S alter.; 9,000.

Section 95.6194 *VOR Federal airway 194* is amended to read in part:

McComb, Miss., VOR; Bay Spring INT, Miss.; *3,000. *2,700—MOCA.
Bay Spring INT, Miss.; *Rose Hill INT, Miss.; **3,000. *3,000—MRA and MCA Rose Hill INT, southwestbound. **2,000—MOCA.

Section 95.6205 *VOR Federal airway 205* is amended to read in part:

Meadow INT, Conn.; *Leroy INT, Mass.; **6,500. *4,500—MRA. **2,300—MOCA.

Section 95.6244 *VOR Federal airway 244* is amended to read in part:

Tonopah, Nev., VOR; Wilson Creek, Nev., VOR; 12,200.

Section 95.6263 *VOR Federal airway 263* is amended to read in part:

Lamar, Colo., VOR; Hugo, Colo., VOR; *6,900. *6,200—MOCA.
Hugo, Colo., VOR; Byers INT, Colo.; *9,000. *8,000—MOCA.
Byers INT, Colo.; Gill, Colo., VOR; *9,000. *8,000—MOCA.

Section 95.6264 *VOR Federal airway 264* is amended to read in part:

St. John, Ariz., VOR; *Socorro, N. Mex., VOR; **12,000. *10,000—MCA Socorro VOR, westbound. **11,100—MOCA.

Section 95.6265 *VOR Federal airway 265* is amended to read in part:

Greenpark INT, Pa.; Walnut INT, Pa.; *4,000. *3,700—MOCA.
Walnut INT, Pa.; Reedsville INT, Pa.; *4,000. *3,400—MOCA.
Reedsville INT, Pa.; Philipsburg, Pa., VOR; *4,000. *3,900—MOCA.

Section 95.6289 *VOR Federal airway 289* is amended to read in part:

Lufkin, Tex., VOR; Pinehill INT, Tex.; *2,400. *2,000—MOCA.
Pinehill INT, Tex.; Gregg Co., Tex., VOR; *2,000. *1,800—MOCA.

Section 95.6291 *VOR Federal airway 291* is amended to read in part:

Winslow, Ariz., VOR; Flagstaff, Ariz., VOR; *10,500. *9,300—MOCA.

From, to, and MEA

Winslow, Ariz., VOR via N alter.; *Frisco INT, Ariz., via N alter.; **9,000. *10,500—MCA Frisco INT, westbound. **8,600—MOCA.
Frisco INT, Ariz., via N alter.; *Flagstaff, Ariz., VOR via N alter.; 11,500. *11,000—MCA Flagstaff VOR, northeastbound.

Section 95.6237 VOR Federal airway 327 is amended to read in part:

Oak Creek INT, Ariz.; Flagstaff, Ariz., VOR; *10,500. *10,000—MOCA.

Section 95.6345 VOR Federal airway 345 is amended to read in part:

Millston INT, Wis.; Augusta INT, Wis.; *3,500. *3,300—MOCA.
Augusta INT, Wis.; Eau Claire, Wis., VOR; 2,800.

Section 95.6430 VOR Federal airway 430 is amended to read in part:

Thief River Falls, Minn., VOR via N alter.; Bemidji, Minn., VOR via N alter.; *3,000. *2,700—MOCA.

Section 95.6438 VOR Federal airway 438 is amended to read in part:

Kodiak, Alaska, VOR; Shuyak DME Fix, Alaska; 4,000.
Shuyak DME Fix, Alaska; Homer, Alaska, VOR; *6,000. *5,900—MOCA.
Kodiak, Alaska, VOR via W alter.; Barren DME Fix, Alaska, via W alter.; *6,000. *4,200—MOCA.
Barren DME Fix, Alaska, via W alter.; Homer, Alaska, VOR via W alter.; *10,000. *5,900—MOCA.

Homer, Alaska, VOR; Skilak INT, Alaska; *5,000. *4,900—MOCA.

Skilak INT, Alaska; Naptowne INT, Alaska; *2,500. *2,300—MOCA.

Naptowne INT, Alaska; Anchorage, Alaska, VOR; *2,000. *1,400—MOCA.
Anchorage, Alaska, VOR; *Big Lake, Alaska, VOR; **2,000. *4,700—MCA Big Lake VOR, northbound. **1,300—MOCA.

Cantwell INT, Alaska; Liberty INT, Alaska; *10,000. *8,700—MOCA.

Liberty INT, Alaska; *Gold INT, Alaska; **7,500. *4,800—MCA Gold INT, southbound. **6,800—MOCA.

Gold INT, Alaska; Fairbanks, Alaska, VOR; 2,500.

Fairbanks, Alaska, VOR; *Chatanika DME Fix, Alaska; **7,500. *7,000—MRA. **5,000—MOCA.

Chatanika DME Fix, Alaska; Fort Yukon DME Fix, Alaska, 183 rad/25NM, *8,000. *7,200—MOCA.

Fort Yukon DME Fix, Alaska, 183 rad/25NM; Fort Yukon, Alaska, VOR; 2,200.

Fairbanks, Alaska, VOR via W alter.; Fort Yukon DME Fix, Alaska, 198 rad/25NM via W alter.; *7,000. *6,800—MOCA.

Fort Yukon DME Fix, Alaska, 198 rad/25NM via W alter.; Fort Yukon, Alaska, VOR via W alter.; 2,200.

Fairbanks, Alaska, VOR via E alter.; Fort Yukon DME Fix, Alaska, 168 rad/25NM via E alter.; *8,000. *7,300—MOCA.

Fort Yukon DME Fix, Alaska, 168 rad/25NM via E alter.; Fort Yukon, Alaska, VOR via E alter.; 2,200.

Section 95.6440 VOR Federal airway 440 is amended to read in part:

McGrath, Alaska, VOR; Ganes Creek DME Fix, Alaska; 6,000.

Ganes Creek DME Fix, Alaska; Yukon INT, Alaska; *8,000. *6,000—MOCA.

Yukon INT, Alaska; Unalakleet, Alaska, VOR; 4,500.

Unalakleet, Alaska, VOR; Nome, Alaska, VOR; 3,000.

See footnotes at end of document.

Section 95.6444 VOR Federal airway 444 is amended to read in part:

From, to, and MEA

Northway, Alaska, VOR; Big Delta, Alaska, VOR; *8,000. *6,800—MOCA.

Livengood INT, Alaska; *Circle DME Fix, Alaska; **9,000. *4,400—MCA Circle DME Fix, southeastbound. **5,200—MOCA.

Circle DME Fix, Alaska; Bettles, Alaska, VOR; 3,500.

Tolovana INT, Alaska, via S alter.; Rampart INT, Alaska, via S alter.; *7,000. *6,600—MOCA.

Rampart INT, Alaska, via S alter.; *Kanuti DME Fix, Alaska, via S alter.; **7,000. *4,400—MCA Kanuti DME Fix, southeastbound. **6,400—MOCA.

Kanuti DME Fix, Alaska, via S alter.; Bettles, Alaska, VOR; via S alter.; *3,500. *3,200—MOCA.

Section 95.6449 VOR Federal airway 449 is amended to read in part:

Oak Hill INT, N.Y.; Albany, N.Y., VOR; *4,400. *3,700—MOCA.

Section 95.6452 VOR Federal airway 452 is amended to delete:

Nome, Alaska, VOR, via N alter.; Moses Point, Alaska, VOR, via N alter.; *6,000. *4,200—MOCA.

Section 95.6454 VOR Federal airway 454 is amended to read in part:

Sinclair INT, Ga.; Madison INT, Ga.; *2,500. *2,000—MOCA.

Section 95.6455 VOR Federal airway 455 is amended to read in part:

Hattiesburg, Miss., VOR, via W alter.; Bay Spring INT, Miss., via W alter.; *3,000. *2,700—MOCA.

Bay Spring INT, Miss., via W alter. *3,000—MRA and MCA Rose Hill INT, southwestbound. **2,000—MOCA.

Section 95.6474 VOR Federal airway 474 is amended to read in part:

Paradise INT, Pa.; Modena, Pa., VOR; *2,500. *2,400—MOCA.

Section 95.6484 VOR Federal airway 484 is amended to read in part:

Grand Junction, Colo., VOR; Gunnison, Colo., VOR; *14,000. *13,500—MOCA.

Section 95.6504 VOR Federal airway 504 is amended to read in part:

Rampart INT, Alaska; *Kanuti DME Fix, Alaska; **7,000. *4,400—MCA Kanuti DME Fix, southeastbound. **6,400—MOCA.

Kanuti DME Fix, Alaska; Bettles, Alaska, VOR; *3,500. *3,200—MOCA.

From, to, MEA, and MAA

Section 95.7086 Jet Route No. 86 is amended to read in part:

Winslow, Ariz., VORTAC; El Paso, Tex., VORTAC; 25,000; 45,000.

Section 95.7123 Jet Route No. 123 is amended to read in part:

Marble DME Fix, Alaska; Kodiak, Alaska, VORTAC; 18,000; 45,000.

Kodiak, Alaska, VORTAC; King Salmon, Alaska, VORTAC; 18,000; 45,000.

Section 95.7125 Jet Route No. 125 is amended to read in part:

Kodiak, Alaska, VORTAC; Anchorage, Alaska, VORTAC; 18,000; 45,000.

2. By amending Subpart D as follows:

From; to—Changeover point; Distance from changeover points:

Section 95.8003 VOR Federal airway changeover points:

V-15 is amended to read in part: Humble, Tex., VOR via E alter.; Navasota, Tex., VOR via E alter.; 30; Humble.

V-22 is amended by adding: Humble, Tex., VOR via N alter.; Dalsetta, Tex., VOR via N alter.; 30; Humble.

Section 95.8005 Jet routes changeover points:

J-125 is amended to read in part: Kodiak, Alaska, VORTAC; Anchorage, Alaska, VORTAC; 120; Anchorage.

(Sec. 307 and 1110, Federal Aviation Act of 1958, 49 U.S.C. 1348, 1510)

Issued in Washington, D.C., on November 1, 1971.

R. S. SLIFF,
Acting Director,
Flight Standards Service.

[FR Doc.71-16329 Filed 11-11-71;8:45 am]

[Docket No. 11481; Amdt. 782]

PART 97—STANDARD INSTRUMENT APPROACH PROCEDURES

Miscellaneous Amendments

This amendment to Part 97 of the Federal Aviation regulations incorporates by reference therein changes and additions to the Standard Instrument Approach Procedures (SIAP's) that were recently adopted by the Administrator to promote safety at the airports concerned.

The complete SIAP's for the changes and additions covered by this amendment are described in FAA Form 3139, 8260-3, 8260-4, 8260-5 and made a part of the public rule making dockets of the FAA in accordance with the procedures set forth in Amendment No. 97-696 (35 F.R. 5609).

SIAP's are available for examination at the Rules Docket and at the National Flight Data Center, Federal Aviation Administration, 800 Independence Avenue SW., Washington, DC 20591. Copies of SIAP's adopted in a particular region are also available for examination at the headquarters of that region. Individual copies of SIAP's may be purchased from the FAA Public Document Inspection Facility, HQ-405, 800 Independence Avenue SW., Washington, DC 20590, or from the applicable FAA regional office in accordance with the fee schedule prescribed in 49 CFR 7.85. This fee is payable in advance and may be paid by check, draft or postal money order payable to the Treasurer of the United States. A weekly transmittal of all SIAP changes and additions may be obtained by subscription at an annual rate of \$125 per annum from the Superintendent of Documents, U.S. Government Printing Office, Washington, D.C. 20402.

Since a situation exists that requires immediate adoption of this amendment,

I find that further notice and public procedure hereon is impracticable and good cause exists for making it effective in less than 30 days.

In consideration of the foregoing, Part 97 of the Federal Aviation regulations is amended as follows, effective on the dates specified:

1. Section 97.23 is amended by establishing, revising, or canceling the following VOR-VOR/DME SIAP's, effective December 9, 1971.

Anniston, Ala.—Anniston-Calhoun County Airport; VOR-A, Amdt. 3; Revised.
 Baudette, Minn.—Baudette International Airport; VOR Runway 30, Amdt. 2; Revised.
 Big Lake, Alaska—Big Lake No. 2 Airport; VOR Runway 6, Amdt. 2; Revised.
 Burlington, Wis.—Burlington Municipal Airport; VOR Runway 29, Original; Established.
 Centerville, Tenn.—Centerville Municipal Airport; VOR Runway 2, Amdt. 1; Revised.
 Chicago, Ill.—Chicago-Hammond Airport; VOR-A, Amdt. 1; Revised.
 Clarksburg, W. Va.—Benedum Airport; VOR Runway 3, Amdt. 6; Revised.
 Duluth, Minn.—Duluth International Airport; VOR Runway 3, Amdt. 9; Revised.
 Elkhart, Ind.—Elkhart Municipal Airport; VOR Runway 27, Amdt. 4; Revised.
 Emporia, Kans.—Emporia Municipal Airport; VOR-A, Amdt. 7; Revised.
 Flint, Mich.—Bishop Airport; VOR Runway 27L, Amdt. 7; Revised.
 Fort Wayne, Ind.—Smith Field; VOR Runway 13, Amdt. 2; Revised.
 Fort Worth, Tex.—Greater Southwest International Dallas-Fort Worth Field; VOR Runway 13, Amdt. 12; Revised.
 Fort Yukon, Alaska—Fort Yukon Municipal Airport; VOR Runway 3, Amdt. 3; Canceled.
 Fort Yukon, Alaska—Fort Yukon Municipal Airport; VOR Runway 21, Amdt. 3; Canceled.
 Harlingen, Tex.—Harlingen Industrial Airport; VOR Runway 13, Amdt. 1; Revised.
 Indianapolis, Ind.—Indianapolis Metropolitan Airport; VOR Runway 32, Original; Established.
 Koloa, Kauai, Hawaii—Poipu Airport; VOR Runway 8, Amdt. 1; Canceled.
 Manning, S.C.—Clarendon County Airport; VOR-A, Amdt. 2; Revised.
 Monroe, N.C.—Monroe Airport; VOR-A, Amdt. 1; Revised.
 New York, N.Y.—John F. Kennedy International Airport; VOR Runway 13L/R, Amdt. 9; Revised.
 Niles, Mich.—Jerry Tyler Memorial Airport; VOR Runway 3, Amdt. 1; Revised.
 O'Neill, Nebr.—O'Neill Municipal Airport; VOR Runway 13, Amdt. 1; Revised.
 Reed City, Mich.—Miller Field; VOR Runway 17, Amdt. 3; Revised.
 Rockford, Ill.—Greater Rockford Airport; VOR Runway 12, Amdt. 10; Revised.
 Roseau, Minn.—Roseau Municipal Airport; VOR Runway 16, Original; Established.
 Roseau, Minn.—Roseau Municipal Airport; VOR Runway 34, Original; Established.
 Roswell, N. Mex.—Roswell Industrial Air Center; VOR-A, Original; Established.
 Roswell, N. Mex.—Roswell Industrial Air Center; VOR Runway 12, Original; Canceled.
 St. Louis, Mo.—Spirit of St. Louis Airport; VOR-A, Amdt. 3; Revised.
 Sioux City, Iowa—Sioux City Municipal Airport; VOR Runway 31, Original; Established.
 Talladega, Ala.—Talladega Municipal Airport; VOR-A, Amdt. 4; Revised.
 Traverse City, Mich.—Cherry Capital Airport; VOR-A, Amdt. 8; Revised.
 Urbana, Ill.—Illini Airport; VOR-A, Amdt. 4; Revised.
 Duluth, Minn.—Duluth International Airport; VOR/DME Runway 21, Amdt. 4; Revised.

Fort Yukon, Alaska—Fort Yukon Municipal Airport; VORTAC Runway 3, Original; Established.
 Fort Yukon, Alaska—Fort Yukon Municipal Airport; VORTAC Runway 21, Original; Established.
 Hilo, Hawaii—General Lyman Field; VOR TAC-A, Original; Established.
 Hilo, Hawaii—General Lyman Field; VOR/DME-A, Amdt. 4; Canceled.
 Manning, S.C.—Clarendon County Airport; VOR/DME-A, Original; Established.
 Monroe, N.C.—Monroe Airport; VOR/DME-A, Original; Established.
 New Madrid, Mo.—County Memorial Airport; VOR/DME-A, Original; Established.
 Port Lavaca, Tex.—Calhoun County Airport; VOR/DME Runway 23, Original; Established.
 St. Louis, Mo.—Spirit of St. Louis Airport; VOR/DME Runway 7, Amdt. 4; Revised.
 Sioux City, Iowa—Sioux City Municipal Airport; VORTAC Runway 13, Amdt. 8; Revised.
 Sioux City, Iowa—Sioux City Municipal Airport; VORTAC Runway 31, Amdt. 17; Revised.
 Talladega, Ala.—Talladega Municipal Airport; VOR/DME Runway 3, Amdt. 2; Revised.

2. Section 97.25 is amended by establishing, revising, or canceling the following SDF-LOC-LDA SIAP's, effective December 9, 1971.

Anniston, Ala.—Anniston-Calhoun Airport; LOC Runway 5, Amdt. 3; Revised.
 Duluth, Minn.—Duluth International Airport; LOC (BC) Runway 27, Amdt. 5; Revised.
 Flint, Mich.—Bishop Airport; LOC (BC) Runway 27L, Amdt. 5; Revised.
 Grand Rapids, Mich.—Kent County Airport; LOC (BC) Runway 8, Amdt. 7; Revised.
 Rockford, Ill.—Greater Rockford Airport; LOC (BC) Runway 18, Amdt. 5; Revised.
 Sioux City, Iowa—Sioux City Municipal Airport; LOC (BC) Runway 13, Amdt. 12; Revised.
 Washington, D.C.—Dulles International Airport; LOC (BC) Runway 1L, Amdt. 1; Revised.
 Norfolk, Va.—Norfolk Regional Airport; LOC/DME (BC) Runway 22, Amdt. 1; Canceled.

3. Section 97.27 is amended by establishing, revising, or canceling the following NDB/ADF SIAP's, effective December 9, 1971.

Anniston, Ala.—Anniston-Calhoun County Airport; NDB Runway 5, Amdt. 8; Revised.
 Columbus, Ga.—Columbus Metropolitan Airport; NDB Runway 5, Amdt. 19; Revised.
 Columbus, Ind.—Columbus Municipal Airport; NDB Runway 5, Amdt. 1; Canceled.
 Duluth, Minn.—Duluth International Airport; NDB Runway 9, Amdt. 12; Revised.
 Elkhart, Ind.—Elkhart Municipal Airport; NDB Runway 9, Amdt. 4; Revised.
 Flint, Mich.—Bishop Airport; NDB Runway 9R, Amdt. 12; Revised.
 Fort Worth, Tex.—Greater Southwest International Dallas-Fort Worth Field; NDB Runway 13, Amdt. 17; Revised.
 Fort Yukon, Alaska—Fort Yukon Municipal Airport; NDB Runway 21, Amdt. 3; Revised.
 Franklin, Pa.—Chess-Lamberton Airport; NDB Runway 29, Amdt. 6; Revised.
 Freeport, Ill.—The Albertus Airport; NDB Runway 24, Amdt. 3; Revised.
 Harlingen, Tex.—Harlingen Industrial Airport; NDB Runway 17R, Amdt. 1; Revised.
 Oxford, Ohio—Miami University Airport; NDB Runway 4, Amdt. 2; Revised.
 Port Huron, Mich.—St. Clair County Airport; NDB-A, Amdt. 2; Revised.
 Port Huron, Mich.—St. Clair County Airport; NDB Runway 4, Amdt. 2; Revised.

Reed City, Mich.—Miller Field; NDB Runway 17, Amdt. 5; Canceled.
 Rockford, Ill.—Greater Rockford Airport; NDB Runway 36, Amdt. 11; Revised.
 St. Louis, Mo.—Spirit of St. Louis Airport; NDB Runway 7, Amdt. 1; Revised.
 Salem, Ill.—Salem-Leckrone Airport; NDB Runway 18, Amdt. 1; Revised.
 Salem, Ill.—Salem-Leckrone Airport; NDB (ADF) Runway 18, Original; Canceled.
 Washington, D.C.—Dulles International Airport; NDB Runway 1R, Amdt. 8; Revised.

4. Section 97.29 is amended by establishing, revising, or canceling the following ILS SIAP's, effective December 9, 1971.

Albuquerque, N. Mex.—Albuquerque International Airport; ILS Runway 35, Amdt. 29; Revised.
 Columbus, Ga.—Columbus Metropolitan Airport; ILS Runway 5, Amdt. 14; Revised.
 Duluth, Minn.—Duluth International Airport; ILS Runway 9, Amdt. 6; Revised.
 Flint, Mich.—Bishop Airport; ILS Runway 9R, Amdt. 4; Revised.
 Fort Worth, Tex.—Greater Southwest International Dallas-Fort Worth Field; ILS Runway 13, Amdt. 17; Revised.
 Norfolk, Va.—Norfolk Regional Airport; ILS Runway 4, Amdt. 13; Revised.
 New York, N.Y.—John F. Kennedy International Airport; ILS Runway 4R, Amdt. 18; Revised.
 Rockford, Ill.—Greater Rockford Airport; ILS Runway 36, Amdt. 14; Revised.
 St. Louis, Mo.—Spirit of St. Louis Airport; ILS Runway 7, Amdt. 1; Revised.
 Wake Island—Wake Island Airport; ILS/DME Runway 10, Amdt. 9; Revised.

5. Section 97.31 is amended by establishing, revising, or canceling the following Radar SIAP's effective December 9, 1971.

Duluth, Minn.—Duluth International Airport; Radar-1, Amdt. 6; Revised
 (Secs. 307, 313, 601, 1110, Federal Aviation Act of 1958; 49 U.S.C. 1438, 1354, 1421, 1510, sec. 6(c) Department of Transportation Act, 49 U.S.C. 1655(c) and 5 U.S.C. 552(a)(1))

Issued in Washington, D.C. on November 3, 1971.

R. S. SLIFF,
 Acting Director,
 Flight Standards Service.

NOTE: Incorporation by reference provisions in §§ 97.10 and 97.20 (35 F.R. 5610) approved by the Director of the Federal Register on May 12, 1969.

[FR Doc. 71-16449 Filed 11-11-71; 8:45 am]

Title 24—HOUSING AND HOUSING CREDIT

Chapter II—Federal Housing Administration, Department of Housing and Urban Development

SUBCHAPTER Q-1—MORTGAGE INSURANCE FOR HOSPITALS

[Docket No. R-71-127]

PART 242—HOSPITALS

Subpart A—Eligibility Requirements

INCLUSION OF PROPRIETARY HOSPITALS

Notice of a proposal to amend the regulations for Part 242 governing mortgage

insurance for nonprofit hospitals to include proprietary hospitals was published at 36 F.R. 13158 (July 15, 1971).

Interested persons were given the opportunity to participate in the rule making through submission of written comments or suggestions on or before August 17, 1971. Two comments were received. The first comment suggested that the terms "profit mortgagor" and "nonprofit mortgagor" be changed to "subsidized or nontax paying mortgagor" and "nonsubsidized or tax paying mortgagor," respectively. This suggestion has not been adopted since Part 242 does not provide for a distinction between profit and nonprofit mortgagor on the basis of payment of taxes or receiving a subsidy.

The National League Program on Health Problems of the Poor and the National Tenant Organization joined in the second comment. Their first suggestion expressed concern that proprietary hospitals would not be responsive to community needs, and would not be approved and regulated in the same manner as the Department of Health, Education, and Welfare approves and regulates Hill-Burton hospitals. This suggestion has not been accepted since HUD operates the hospital mortgage insurance program in conjunction with the Department of Health, Education, and Welfare by memorandum of agreement between the Departments. Project approval and processing are two of the several items which are the responsibility of HEW.

Their second suggestion was to preclude participation in the program by a proprietary hospital where physicians practicing in the service area of the facility have a financial interest in the hospital. This suggestion has not been adopted since neither the statute nor the legislative history indicates that it was intended that physicians were to be excluded from participating as an investor in the mortgagor. Further, questions of conflict of interest are more properly the function of the professional society or organization which regulates the conduct and ethics of the members of the profession.

After consideration of all such relevant matter, the amendment as proposed is hereby adopted without change and is set forth below.

I hereby find that it is in the public interest to make the benefits of these regulations available to the public at the earliest possible date. Therefore, these regulations shall be effective upon publication in the FEDERAL REGISTER (11-12-71).

EUGENE A. GULLEDGE,
Federal Housing Commissioner.

The principal revisions are as follows:
The title of the subchapter, "Subchapter Q-1—Mortgage insurance for Nonprofit Hospitals", is changed to "Subchapter Q-1—Mortgage Insurance for Hospitals".

The title of the part, "Part 242—Nonprofit Hospitals", is changed to "Part 242—Hospitals".

Subpart A, "Eligibility Requirements", is being revised as follows:

In § 242.1(b)(3), the definition of "Hospital" is revised to include a proprietary facility.

Section 242.23 is amended to add a profit mortgagor as a mortgagor eligible for mortgage insurance.

Section 242.51 is revised to provide separate procedures with respect to prepayment privilege and prepayment charges for profit mortgagors, under paragraph (a), and nonprofit mortgagors, under paragraph (b). Paragraph (b)(1) permits, with the prior written approval of the Commissioner, partial prepayments by nonprofit mortgagors for the purpose of reducing succeeding monthly payments of the remaining balance as recast over the remaining portion of the original mortgage term, and paragraph (b)(2)(iii) provides that no prepayment charge shall be made where the prepayment is made from the proceeds of a Federal grant.

Section 242.51(c), regarding late charges, is redesignated as § 242.52.

Section 242.57(b) is revised to provide separate procedures with respect to the use of a letter of credit in lieu of certain cash deposits for profit mortgagors, under subparagraph (1), and nonprofit mortgagors, under subparagraph (2).

Section 242.67(b), relating to waiver of compliance with certain labor standards in the case of donated services, has been amended to limit its applicability to private nonprofit hospitals.

Subpart B, "Contract Rights and Obligations", is revised as follows:

Section 242.251, regarding incorporation by reference, is amended to delete the word "nonprofit".

Section 242.260 is amended to delete the word "nonprofit" in order to make the insurance benefits applicable to all hospitals.

The amendments to Part 242 are set out in full below:

Sec.	
242.51	Prepayment privilege and prepayment charges.
242.52	Late charge.

§ 242.1 Definitions.

* * * * *

(b) "Hospital" means a facility—

* * * * *

(3) Which is a proprietary facility, or facility of a private nonprofit corporation or association, licensed or regulated by the State (or, if there is no State law providing for such licensing or regulation by the State, by the municipality or other political subdivision in which the facility is located).

* * * * *

§ 242.23 Eligible mortgagors.

The mortgagor shall be either a private nonprofit corporation or association or a profit mortgagor, shall be approved by the Commissioner, and shall possess the powers necessary and incidental to operating a hospital.

§ 242.51 Prepayment privilege and prepayment charges.

(a) Profit mortgagors. In the case of a profit mortgagor, the following provisions shall be applicable:

(1) Prepayment privilege. The mortgage shall contain a provision permitting the mortgagor to prepay the mort-

gage in whole or in part upon any interest payment date after giving the mortgagee 30 days' notice in writing in advance of its intention to so prepay.

(2) Prepayment charge. The mortgage may contain a provision for such charge, in the event of prepayment of principal, as may be agreed upon between the mortgagor and the mortgagee subject to the following:

(i) The mortgagor shall be permitted to prepay up to 15 percent of the original principal amount of the mortgage in any 1 calendar year without any such charge.

(ii) Any reduction in the original principal amount of the mortgage which the Commissioner may require pursuant to § 242.29(c) shall not be construed as a prepayment of the mortgage.

(b) Nonprofit mortgagors. In the case of a nonprofit mortgagor, the following provisions shall be applicable:

(1) Prepayment privilege. The mortgage indebtedness may be prepaid in full and the Commissioner's controls terminated only upon the condition that the Commissioner's prior written consent is obtained and upon such terms and conditions as the Commissioner may prescribe. With the prior written approval of the Commissioner, partial prepayments may be made for the purpose of reducing succeeding monthly payments of the remaining balance as recast over the remaining portion of the original mortgage term.

(2) Prepayment charge. The mortgage may contain a provision for such charge, in the event of prepayment of principal, as may be agreed upon between the mortgagor and the mortgagee, subject to the following:

(i) The mortgagor shall be permitted to prepay up to 15 percent of the original principal amount of the mortgage in any 1 calendar year without any such charge.

(ii) Any reduction in the original principal amount of the mortgage which the Commissioner may require pursuant to § 242.29(c) shall not be construed as a prepayment of the mortgage.

(iii) No charge shall be made where the prepayment is made from the proceeds of a Federal grant.

§ 242.52 Late charge.

The mortgage may provide for the collection by the mortgagee of a late charge, not to exceed 2 cents for each dollar of each payment to interest or principal more than 15 days in arrears, to cover the expense involved in handling delinquent payments. Late charges shall be separately charged to and collected from the mortgagor and shall not be deducted from any aggregate monthly payment.

§ 242.57 Funds and finances—insured advances—general requirements.

* * * * *

(b) Letter of credit—(1) Profit mortgagors. In the case of a profit mortgagor, the mortgagee may accept a letter of credit in lieu of the cash deposit required by paragraph (a)(2) of this section.

(2) Nonprofit mortgagors. In the case of a nonprofit mortgagor, the mortgagee may accept a letter of credit in lieu of the

cash deposit required by paragraphs (a) (1) and (2) of this section. If a letter of credit is accepted in lieu of the cash deposit required by paragraph (a) (1) of this section, the mortgage proceeds may be advanced prior to any demand being made on the letter of credit.

§ 242.67 Labor standards.

(b) *Waiver of compliance with contract requirements—nonprofit mortgagors.* In the case of a nonprofit mortgagor, the Commissioner may waive the requirement for compliance with the contract provisions prescribed in paragraph (a) of this section in cases or classes of cases where laborers or mechanics, not otherwise employed at any time in the construction or rehabilitation of the hospital, voluntarily donate their services without compensation for the purpose of lowering the costs of construction and where the Commissioner determines that full credit has been received by the mortgagor for any amounts saved through such donated services.

§ 242.251 Incorporation by reference.

All of the provisions of Subpart B, Part 207 of this chapter covering mortgages insured under section 207 of the National Housing Act apply to mortgages on hospitals insured under section 242 of the National Housing Act, except the following: Section 207.259 *Insurance benefits.*

§ 242.260 Insurance benefits.

All of the provisions of § 207.259 of this chapter relating to insurance benefits apply to mortgages on hospitals insured under this subpart, except that in a case where the mortgage involves the financing or refinancing of an existing hospital pursuant to § 242.93 and the commitment for insuring such mortgage is issued on or after April 1, 1969, the insurance claim shall be paid in cash unless the mortgagee files a written request for payment in debentures. If such a request is made, the claim shall be paid in debentures issued in multiples of \$50, with any balance less than \$50 to be paid in cash.

[FR Doc.71-16534 Filed 11-11-71;8:47 am]

Title 41—PUBLIC CONTRACTS AND PROPERTY MANAGEMENT

Chapter 5A—Federal Supply Service, General Services Administration

PART 5A-1—GENERAL

Delegations of Authority and Selection and Appointment of Contracting Officers' Representatives

The table of contents for Part 5A-1 is amended to add the following entries:

Sec.	
5A-1.402	Authority of contracting officers.
5A-1.404-70	Selection and appointment of contracting officers' representatives.

Subpart 5A-1.4—Procurement Responsibility and Authority

1. Section 5A-1.402 is added as follows:

§ 5A-1.402 Authority of contracting officers.

Delegations of authority to Federal Supply Service contracting officers are contained in the GSA Delegations of Authority Manual, Chap. 7 (ADM P 5450.39).

2. Section 5A-1.404-70 is added as follows:

§ 5A-1.404-70 Selection and appointment of contracting officers' representatives.

(a) *Designation.* A contracting officer may designate any Government employee who is appropriately qualified to act as his authorized representative. A contracting officer's representative may be designated by name and position title, or such designation may be by position title only, so long as the designation is unambiguous and understandable to all concerned. Each designation shall be in writing and shall define the scope and limitations of the authorized representative's authority. Designation of contracting officer's representative will remain in effect throughout the life of the contract unless (1) sooner revoked by the contracting officer, or (2) revoked by transfer of a contracting officer's representative who has been designated by name and position title. The authority of an individual designated as a representative by position title only is terminated upon his transfer from that position. Copies of designations of contracting officer's representatives shall be placed in appropriate contract files. A copy of each designation and any change or termination thereof shall be furnished promptly to each contractor concerned, except under the following circumstances. Nothing in this section will be construed to require designation as a contracting officer's representative of each individual of an activity responsible for accomplishment of broad functions of contract administration (e.g., engineering evaluation, testing, quality control, inspection). (Also see § 5A-53.472 of this chapter.)

(b) *Authority.* A contracting officer's representative may, if so designated, represent the contracting officer with respect to one or more contracts and may, to the extent not specifically prohibited by the terms of the contract concerned, be authorized to take any or all action thereunder which could be lawfully taken by the contracting officer, except that in no event shall an authorized representative, by virtue only of his designation as such, be empowered to execute or agree to any contract or modification thereof. However, the contracting officer may empower his authorized representatives to issue change orders under the Changes clause, provided such change orders do not involve a change in unit price, total contract price, quantity, quality, or delivery schedule. Change orders issued by authorized representatives shall contain the following statement: "In accepting

this change order the contractor agrees that the price and all other terms and conditions of the contract remain unchanged." The contractor shall also be instructed not to proceed under the change order until he has executed (as accepted) the quoted statement and returned it to the authorized representative.

(c) *Personnel assigned to a procurement office.* A person assigned to and performing his primary duty within a procurement office, and who is under the supervision of a contracting officer, does not require designation as a representative nor designation in a contractual document to perform his assigned duties. Such a person is considered to be a subordinate of the contracting officer, acting in his behalf and as such has the inherent authority to perform acts as assigned by the contracting officer. The contracting officer cannot authorize subordinates who are not formally designated contracting officers (§ 5A-1.404) to sign any contractual document or letter where the signature of a contracting officer is required.

(Sec. 205(c), 63 Stat. 390; 40 U.S.C. 486(c); and 41 CFR 5-1.101(c))

Effective date. These regulations are effective November 3, 1971.

Dated: November 3, 1971.

L. E. SPANGLER,
Acting Commissioner,
Federal Supply Service.

[FR Doc.71-16570 Filed 11-11-71;8:50 am]

Chapter 8—Veterans Administration

PART 8-2—PROCUREMENT BY FORMAL ADVERTISING

PART 8-4—SPECIAL TYPES AND METHODS OF PROCUREMENT

Miscellaneous Amendments

Chapter 8 is amended as follows:

1. Section 8-2.202-50 is added to read as follows:

§ 8-2.202-50 Acknowledgement of receipt of amendments to invitations for bids.

Each invitation for bids for supplies, equipment or services shall contain on the face of the bid the following notice:

If it is necessary to amend this invitation, amendments forwarded by mail will be forwarded by certified mail, return receipt requested. The signature of an employee of the bidder authorized to sign bids on the return receipt for such amendment will be the acknowledgement of receipt of the amendment. Amendments may also be forwarded by telegram or other means. The bidder shall acknowledge such amendment(s) as provided for elsewhere in the invitation.

2. Section 8-4.5003-4 is added to read as follows:

§ 8-4.5003-4 Application of 6 percent architect-engineer fee limitation.

(a) The 6 percent fee limitation on architect-engineer services set forth in

section 304(b) of the Federal Property and Administrative Services Act of 1949, as amended, applies to those services generally required in preparing the working drawings and specifications which form the basis for bidding and for the award of construction contract. The fixed fee limitation will not include the following services:

(1) Investigative services including but not limited to:

(i) Determination of program requirements including schematic or preliminary plans and estimates.

(ii) Determination of feasibility of proposed project.

(iii) Preparation of measured drawings of existing facility.

(iv) Subsurface investigation.

(v) Structural, electrical, and mechanical investigation of existing facility.

(vi) Surveys: Topographic, boundary, utilities, etc.

(2) Special consultant services not normally available in organizations of architects or architect-engineers not specifically applied to the actual preparation of working drawings or specifications of the project for which the services are required.

(3) Other:

(i) Reproduction of approved designs through models, color renderings, photographs, or other presentation media.

(ii) Travel and per diem allowances other than those required for the development and review of working drawings and specifications.

(iii) Supervision or inspection of construction, review of shop drawings or samples and other services performed during the construction phase.

(iv) All other services that are not integrally a part of the production and delivery of plans, designs, and specifications.

(4) The cost of reproducing drawings and specifications for bidding and their distribution to prospective bidders and plan file rooms.

(b) The total cost of the architect-engineer services contracted for may not exceed 6 percent of the estimated cost of the construction project plus the estimated cost of related services and activities such as those shown in paragraph (a) of this section. To support project submissions, VA Form 10-6031, Application for Construction Project and Initial Equipment, or VA Form 10-1193, Minor Improvement, Building Service Equipment Replacement, and Nonrecurring Maintenance and Repair Proposal, and VA Form 08-6238, Construction Cost Estimate, will be used and the applicable proposed technical services shown in detail.

(c) The policy set forth in this section will allow more latitude in the negotiation of architect-engineer services; it does not, however, relieve the contracting officer of his responsibility to determine that the fee negotiated is consistent with the services to be performed and the nature of the project. In negotiating such contracts and modifications thereto, the contracting officer will utilize all technical, fiscal, and engineering services available to him. The architect-engineer contract ordinarily will cover all services to be rendered by the contractor. To assure that the intent of the statute is not violated, the contracting officer will maintain suitable records to be able to isolate the amount in the total fee which applies only to the development of plans and specifications to which the 6 percent applies.

(Sec. 205(c), 63 Stat. 389, as amended, 40 U.S.C. 486(c); sec. 210(c), 73 Stat. 1114, 38 U.S.C. 210(c))

These regulations are effective December 10, 1971.

Approved: November 8, 1971.

By direction of the Administrator.

[SEAL]

FRED B. RHODES,
Deputy Administrator.

[FR Dec.71-16555 Filed 11-11-71;8:48 am]

Title 43—PUBLIC LANDS: INTERIOR

Chapter II—Bureau of Land Management, Department of the Interior

[Circular No. 2316]

PART 2780—SPECIAL AREAS

Subpart 2785—Sales of Unintentional Trespass Lands

The purpose of this amendment is to delete from the regulations those that implemented the Act of September 26, 1968 (43 U.S.C. 1431-35). This act authorized the sale of certain land that was affected by unintentional trespass on or before September 26, 1968. The Act expired on September 26, 1971. Subpart 2785 is being deleted in its entirety. The regulations contained therein will be applied to sales initiated under the regulations prior to September 26, 1971, and which, in accordance with section 5 of the Act, may still be completed. No other substantive changes are intended.

It is the policy of the Department of the Interior to give notice of proposed rule making and to invite the public to participate in rule making except where such participation would be impracticable, unnecessary, or contrary to the public interest and a specific finding to this effect is published with the rules or regulations (36 F.R. 8336, May 4, 1971). Public participation is unnecessary in this case since the amendment simply removes provisions from the regulations, the legal effect of which has expired by operation of law.

Subpart 2785 of Chapter II, Title 43 of the Code of Federal Regulations is deleted in its entirety.

Effective date: November 12, 1971.

HARRISON LOESCH,
Assistant Secretary
of the Interior.

NOVEMBER 8, 1971.

[FR Dec.71-16564 Filed 11-11-71;8:49 am]

Title 47—TELECOMMUNICATION

Chapter I—Federal Communications Commission

[Docket No. 19150; FCC 71-1123]

PART 1—PRACTICE AND PROCEDURE

PART 21—DOMESTIC PUBLIC RADIO SERVICES (OTHER THAN MARITIME MOBILE)

PART 74—EXPERIMENTAL, AUXILIARY, SPECIAL BROADCAST AND OTHER PROGRAM DISTRIBUTIONAL SERVICES

PART 89—PUBLIC SAFETY RADIO SERVICES

PART 91—INDUSTRIAL RADIO SERVICES

PART 93—LAND TRANSPORTATION RADIO SERVICES

PART 95—CITIZENS RADIO SERVICE Spectrum Management

First report and order. In the matter of spectrum management; establishment of first Regional Spectrum Management Center in Chicago, Ill.; and amendment of Parts 1, 21, 74, 89, 91, 93, and 95 of the Commission's rules relating to Land Mobile allocations and assignments.

1. This proceeding commenced with the adoption of a notice of proposed rule making on February 3, 1971. That notice was published in (1) the February 10, 1971, edition of the FEDERAL REGISTER at Volume 36, Page 2793 (36 F.R. 2793); and (2) in Volume 27 (2d) of the Commission's reports at Page 400 (27 FCC (2d) 400). Comments and reply comments were invited; and received within the times specified in the notice. All comments and reply comments were carefully read and considered before arriving at the conclusions noted herein.

2. Our proposal in this proceeding concerned the establishment of new systems, techniques, and methodologies for the more efficient management of that portion of the radio spectrum allocated for Land Mobile purposes—as reflected in Part 2 of the Commission's rules. It was geographically confined in its applicability to an area of approximately 96,000 square miles with Chicago, Ill., at the approximate center.

3. Intimately tied to the establishment of new systems, techniques, and methodologies was the proposed establishment of the data base deemed necessary for an effective frequency management system. It is with respect to establishing a data base and the means, methods, and times for so doing that this first report and order is basically directed. In subsequent reports and orders, the other substantive issues raised in this proceeding will be resolved.

4. All persons commenting agreed that an adequate data base is an absolute prerequisite to any meaningful systems,

techniques, or methodologies of frequency management. This means, in short, that certain critical items of information concerning radio systems—assigned frequencies, power, antenna heights, transmitter locations, for example—must be collected and verified at specified time intervals in order that the soundest judgment possible may be exercised in the process of licensing Land Mobile radio stations and systems in the public interest.

5. To assist in establishing or constructing a data base, it was pointed out in our notice that a new ADP-oriented application form to replace the existing FCC Form 400 would be devised.¹ A new form has in fact been devised and is designated FCC Form No. 425. The form has been approved by the Office of Management and Budget pursuant to that agency's authority under Public Law 90-620, 82 Stat. 1302 (Oct. 22, 1968), 44 U.S.C. 3501 et seq. It was also proposed in our notice that data base collection be geared to license renewals and that license terms be reduced to 1 year rather than the present 5 years. In view of industry's strong opposition to this approach, no change in license terms is being ordered at this time, nor will our data base collection efforts be tied to license renewals. All licensees (as will appear more clearly hereinafter) in the Chicago area will be required by virtue of our order in this document to cooperate in the establishment of a data base—by completing portions of the new Form 425 which is being approved and adopted in this report and order.

6. With the new Form 425, construction of an adequate data base for the Chicago Regional Spectrum Management operation is now practicable. At the same time, it is also practicable to begin accumulating data with the new form in areas of the country other than Chicago. By so doing, a uniform implementation of Regional Spectrum Management concepts in these areas at some later date can be effected more efficiently and expeditiously. Thus, in addition to using the new Form 425 for the construction of the Chicago Regional data base, which encompasses an initial information gathering process as well as use of the form in applying for new, modified, and renewal licenses, the form will also be used by persons applying for the new frequencies made available by the Commission in its order in Docket No. 18261, that is, 470-512 MHz frequencies in the cities of New York, Boston, Los Angeles, San Francisco, Cleveland, Washington, D.C., Detroit, Philadelphia, and Pittsburgh.

7. The appendices² to this document contain a facsimile of the new form, together with its instructions and the full

text of the rules amendments concerning use of the form. To briefly synthesize the terms of use, the new Form 425 will be required to be used in the Chicago Region (as defined in the various affected parts of the rules) as follows:

For new and modified licenses and for renewal of existing licenses. Persons applying for new, modified, or renewed Land Mobile licenses that specify operations in the Chicago Regional Area must file their applications together with appropriate fees at the Commission's offices in Washington beginning April 1, 1972. After January 1, 1973, however, all persons in this category will file their applications—with fees—at the Commission's Regional Spectrum Management Offices in Chicago.³

Data base collection. All Land Mobile licensees in the Chicago Region—with the exception of persons whose licenses expire at any time between April 1, 1972, and December 31, 1972—are required to file a copy of the 425—completed in accordance with the supplemental instructions relating to data base collection pursuant to the time schedule specified in the supplemental instructions. Persons whose licenses expire between April 1, 1972, and December 31, 1972, should file for license renewal on the Form 425 in Washington—with the appropriate fee. After December 31, 1972, renewals will be filed in Chicago.⁴

8. The rules adopted herein, together with the new Application Form 425 and its instructions constitute the initial ordering step in implementing our regional approach to spectrum management. A second report and order (and perhaps others) will be forthcoming in this docket proceeding. In summary, the Commission finds that it is in the public interest to adopt the rules, form, and instructions contained in the appendices. By so doing, more effective management of the spectrum will be enhanced.

9. In view of the foregoing and pursuant to the authority contained in sections 4(i), 301, 303, 307, and 308 of the Communications Act of 1934, as amended: *It is ordered*, That effective December 23, 1971, Parts 1, 21, 74, 89, 91, 93, and 95 of the Commission's rules are amended in the manner set forth below. (Secs. 4, 303, 307, 308; 48 Stat., as amended, 1066, 1082, 1083, 1084; 47 U.S.C. 154, 303, 307, 308)

Adopted: October 28, 1971.

Released: November 10, 1971.

FEDERAL COMMUNICATIONS
COMMISSION,⁵

[SEAL] BEN F. WAPLE,
Secretary.

¹ Except Domestic Public Land Mobile and Rural Radio Services, which will continue to file at the Commission's offices in Washington, D.C.

² Except Domestic Public Land Mobile and Rural Radio Services, which will continue to file FCC Form 405 at Washington, D.C.

³ Commissioner Reid not participating.

APPENDIX A

Parts 1, 21, 74, 89, 91, 93, and 95 are amended as follows:

A. Part 1—Practice and Procedure:

1. In § 1.533, paragraph (a)(3) is amended and subparagraph (10) is added to read as follows:

§ 1.533 Application forms for authority to construct a new station or make changes in existing station.

(a) * * *

(3) FCC Form 313 "Application for Authorization in the Auxiliary Broadcast Services" except as provided in subparagraph (10) of this paragraph.

* * *

(10) FCC Form 425 "Application for Radio Station Authorization." Beginning April 1, 1972, this form shall be used by applicants who propose to operate Remote Pickup Broadcast Stations on certain frequencies in the Chicago, Ill., Regional Area. The frequencies and the Regional Area are defined in Subpart D of Part 74 of this chapter.

* * *

2. In § 1.536, paragraph (b) is amended and subparagraph (9) is added to read as follows:

§ 1.536 Application for license to cover construction permit.

(b) * * *

(3) FCC Form 313 "Application for Authorization in the Auxiliary Broadcast Services" except as provided in subparagraph (9) of this paragraph.

* * *

(9) FCC Form 425 "Application for Radio Station Authorization." Beginning April 1, 1972, this form shall be used by applicants who propose to operate Remote Pickup Broadcast Stations on certain frequencies in the Chicago, Ill., Regional Area. The frequencies and the Regional Area are defined in Subpart D of Part 74 of this chapter.

3. In § 1.539, paragraph (d)(3) is amended and subparagraph (9) is added to read as follows:

§ 1.539 Application for renewal of license.

(d) * * *

(3) FCC Form 313 "Application for Authorization in the Auxiliary Broadcast Services." To be used for all applications for renewal of regular licenses of auxiliary broadcasting stations, except as provided in subparagraph (9) of this paragraph.

* * *

(9) FCC Form 425 "Application for Radio Station Authorization." To be used by licensees to renew licenses for Remote Pickup Broadcast Stations which operate on certain frequencies in the Chicago, Ill., Regional Area, beginning April 1, 1972. The frequencies and the Regional Area are defined in Subpart D of Part 74 of this chapter.

4. In § 1.922, a new form number and title are added in appropriate numerical sequence to read as follows:

¹ It was also pointed out that use of the form would commence on July 1, 1971. For a variety of reasons it was impracticable to adhere to the July 1, 1971, schedule. As the remainder of this report and order will reveal, a mandatory use date of Apr. 1, 1972, is being ordered.

² Appendices B-D filed as part of the original document.

§ 1.922 Forms to be used.

425 Application for Radio Station Authorization (Industrial, Public Safety, Land Transportation, Broadcast Remote Pickup and Citizens Class A).

5. In § 1.924, paragraph (b) (2) (i) is amended and subdivision (iv) is added to read as follows:

§ 1.924 Assignment or transfer of control, voluntary and involuntary.

(b) * * *

(i) FCC Form 400: for assignment of station authorization in services under Parts 89, 91, and 93 of this chapter, except as provided in subdivisions (ii) and (iv) of this subparagraph. Attached thereto shall be a signed letter from proposed assignor stating his desire to assign his current authorization in accordance with the rules governing the particular service involved.

(iv) FCC Form 425: for assignment of station authorizations for base, mobile, and fixed stations authorized to operate on frequencies below 950 MHz in services under Parts 89, 91, and 93 of this chapter in the Chicago, Ill., Regional Area, and for assignment of authorization for all stations operating in the band 470-512 MHz. The Chicago Regional Area is defined in Parts 89, 91, 93, and 95 of this chapter.

6. In § 1.926, paragraph (b) is amended to add a new subparagraph (5) as follows:

§ 1.926 Application for renewal of license.

(b) * * *

(5) Beginning April 1, 1972, applications for renewal of licenses for base, mobile and fixed stations operating on frequencies below 950 MHz in the Public Safety, Industrial, Land Transportation Radio Services, and for Class A Citizens Stations which are located in the Chicago, Ill., Regional Area (defined in Parts 89, 91, 93, and 95 of this chapter) shall be filed on FCC Form 425. Such applications shall be filed at the Commission's Washington, D.C., office until January 1, 1973. After January 1, 1973, they shall be filed at the Commission's Chicago Regional Office.

7. In § 1.951, a new paragraph (d) is added as follows:

§ 1.951 How applications are distributed.

(d) Chicago, Ill., Regional Office (beginning January 1, 1973); applications for base, mobile and fixed stations to operate on frequencies below 950 MHz

within the Chicago, Ill., Region (defined in Parts 89, 91, 93, and 95 of this chapter) filed in the Public Safety, Land Transportation, and Industrial (excluding Industrial Radiolocation) Services, and for Class A Citizens Radio stations.

B. Part 21—Domestic Public Radio Services (other than Maritime Mobile):

1. In § 21.14, paragraph (a), a note is added to read as follows:

§ 21.14 Forms to be used.

(a) * * *

NOTE: Beginning April 1, 1972, all applicants filing FCC Form 401 pursuant to the foregoing or following paragraphs of this section and proposing to operate stations in the Domestic Public Land Mobile or Rural Radio Services, including frequencies made available in the bands 470-512 MHz, and located in the Chicago Regional Area as defined below must accompany Form 401 with FCC Form 425 in order to be considered a complete application. The Chicago Regional Area consists of the counties listed below:

ILLINOIS

- 1. Boone.
- 2. Bureau.
- 3. Carroll.
- 4. Champaign.
- 5. Christian.
- 6. Clark.
- 7. Coles.
- 8. Cook.
- 9. Cumberland.
- 10. De Kalb.
- 11. De Witt.
- 12. Douglas.
- 13. Du Page.
- 14. Edgar.
- 15. Ford.
- 16. Fulton.
- 17. Grundy.
- 18. Henry.
- 19. Iroquois.
- 20. Jo Daviess.
- 21. Kane.
- 22. Kankakee.
- 23. Kendall.
- 24. Knox.
- 25. Lake.
- 26. La Salle.
- 27. Lee.
- 28. Livingston.
- 29. Logan.
- 30. Macon.
- 31. Marshall.
- 32. Mason.
- 33. McHenry.
- 34. McLean.
- 35. Menard.
- 36. Mercer.
- 37. Moultrie.
- 38. Ogle.
- 39. Peoria.
- 40. Piatt.
- 41. Putnam.
- 42. Rock Island.
- 43. Sangamon.
- 44. Shelby.
- 45. Stark.
- 46. Stephenson.
- 47. Tazewell.
- 48. Vermillion.
- 49. Warren.
- 50. Whiteside.
- 51. Will.
- 52. Winnebago.
- 53. Woodford.

INDIANA

- 1. Adams.
- 2. Allen.
- 3. Benton.
- 4. Blackford.
- 5. Boone.
- 6. Carroll.
- 7. Cass.
- 8. Clay.
- 9. Clinton.
- 10. De Kalb.
- 11. Delaware.
- 12. Elkhart.
- 13. Fountain.
- 14. Fulton.
- 15. Grant.
- 16. Hamilton.
- 17. Hancock.
- 18. Hendricks.
- 19. Henry.
- 20. Howard.
- 21. Huntington.
- 22. Jasper.
- 23. Jay.
- 24. Kosciusko.
- 25. Lake.
- 26. Lagrange.
- 27. La Porte.
- 28. Madison.
- 29. Marion.
- 30. Marshall.
- 31. Miami.
- 32. Montgomery.
- 33. Morgan.
- 34. Newton.
- 35. Noble.
- 36. Owen.
- 37. Parke.
- 38. Porter.
- 39. Pulaski.
- 40. Putnam.
- 41. Randolph.
- 42. St. Joseph.
- 43. Starke.
- 44. Steuben.
- 45. Tippecanoe.
- 46. Tipton.
- 47. Vermillion.
- 48. Vigo.
- 49. Wabash.
- 50. Warren.
- 51. Wells.
- 52. White.
- 53. Whitley.

IOWA

- 1. Cedar.
- 2. Clinton.
- 3. Dubuque.
- 4. Jackson.
- 5. Jones.
- 6. Muscatine.
- 7. Scott.

MICHIGAN

- 1. Allegan.
- 2. Barry.
- 3. Berrien.
- 4. Branch.
- 5. Calhoun.
- 6. Cass.
- 7. Clinton.
- 8. Eaton.
- 9. Hillsdale.
- 10. Ingham.
- 11. Ionia.
- 12. Jackson.
- 13. Kalamazoo.
- 14. Kent.
- 15. Lake.
- 16. Mason.
- 17. Mecosta.
- 18. Montcalm.
- 19. Muskegon.
- 20. Newaygo.
- 21. Oceana.
- 22. Ottawa.
- 23. St. Joseph.
- 24. Van Buren.

OHIO

- 1. Defiance.
- 2. Mercer.
- 3. Paulding.
- 4. Van Wert.
- 5. Williams.

WISCONSIN

- 1. Adams.
- 2. Brown.
- 3. Calumet.
- 4. Columbia.
- 5. Dane.
- 6. Dodge.
- 7. Door.
- 8. Fond du Lac.
- 9. Grant.
- 10. Green.
- 11. Green Lake.
- 12. Iowa.
- 13. Jefferson.
- 14. Juneau.
- 15. Kenosha.
- 16. Kewaunee.
- 17. Lafayette.
- 18. Manitowoc.
- 19. Marquette.
- 20. Milwaukee.
- 21. Outagamie.
- 22. Ozaukee.
- 23. Racine.
- 24. Richland.
- 25. Rock.
- 26. Sauk.
- 27. Sheboygan.
- 28. Walworth.
- 29. Washington.
- 30. Waukesha.
- 31. Waupaca.
- 32. Waushara.
- 33. Winnebago.

C. Part 74—Experimental, Auxiliary, and Special Broadcast, and Other Program Distributional Services:

1. A new § 74.404 is added to read as follows:

§ 74.404 Use of FCC Form 425.

(a) Beginning April 1, 1972, applications on FCC Form 425 in lieu of FCC Form 313 shall be submitted by applicants proposing to operate on the frequencies specified in paragraph (c) of this section and who propose to operate such stations in the Chicago, Ill., Regional Area defined in paragraph (d) of this section. Form 425 shall be used to apply for new facilities or to apply for modification, renewal, or assignment of existing authorizations.

(b) Applications on FCC Form 425 shall be submitted to the Commission's office at Washington, D.C. 20554, until January 1, 1973, at which time they shall be submitted to the Commission's Chicago Regional Office. The address of the Regional Office will be published at a later date.

(c) FCC Form 425 must be used to file for the following frequencies in the Chicago Regional Area:

(i)	GROUP				
	D	E	F	G	H
(Mc/s)	(Mc/s)	(Mc/s)	(Mc/s)	(Mc/s)	(Mc/s)
26.15	26.17	26.19	26.21	26.23	
26.25	26.27	26.29	26.31	26.33	
26.35	26.37	26.39	26.41	26.43	

(2)

GROUP		
I	J	K
(Mc/s)	(Mc/s)	(Mc/s)
25, 11	26, 13	152, 87
26, 45	26, 47	152, 93
		152, 99
		153, 05
		153, 11
		153, 17
		153, 23
		153, 29
		153, 33

(d) The Chicago, Ill., Region is defined to consist of the counties listed below:

ILLINOIS

1. Boone.	28. Livingston.
2. Bureau.	29. Logan.
3. Carroll.	30. Macon.
4. Champaign.	31. Marshall.
5. Christian.	32. Mason.
6. Clark.	33. McHenry.
7. Coles.	34. McLean.
8. Cook.	35. Menard.
9. Cumberland.	36. Mercer.
10. De Kalb.	37. Moultrie.
11. De Witt.	38. Ogle.
12. Douglas.	39. Peoria.
13. Du Page.	40. Piatt.
14. Edgar.	41. Putnam.
15. Ford.	42. Rock Island.
16. Fulton.	43. Sangamon.
17. Grundy.	44. Shelby.
18. Henry.	45. Stark.
19. Iroquois.	46. Stephenson.
20. Jo Daviess.	47. Tazewell.
21. Kane.	48. Vermillion.
22. Kankakee.	49. Warren.
23. Kendall.	50. Whiteside.
24. Knox.	51. Will.
25. Lake.	52. Winnebago.
26. La Salle.	53. Woodford.
27. Lee.	

INDIANA

1. Adams.	28. Madison.
2. Allen.	29. Marion.
3. Benton.	30. Marshall.
4. Blackford.	31. Miami.
5. Boone.	32. Montgomery.
6. Carroll.	33. Morgan.
7. Cass.	34. Newton.
8. Clay.	35. Noble.
9. Clinton.	36. Owen.
10. De Kalb.	37. Parke.
11. Delaware.	38. Porter.
12. Elkhart.	39. Pulaski.
13. Fountain.	40. Putnam.
14. Fulton.	41. Randolph.
15. Grant.	42. St. Joseph.
16. Hamilton.	43. Starke.
17. Hancock.	44. Steuben.
18. Hendricks.	45. Tippecanoe.
19. Henry.	46. Tipton.
20. Howard.	47. Vermillion.
21. Huntington.	48. Vigo.
22. Jasper.	49. Wabash.
23. Jay.	50. Warren.
24. Kosciusko.	51. Wells.
25. Lake.	52. White.
26. Lagrange.	53. Whitley.
27. La Porte.	

IOWA

1. Cedar.	5. Jones.
2. Clinton.	6. Muscatine.
3. Dubuque.	7. Scott.
4. Jackson.	

MICHIGAN

1. Allegan.	7. Clinton.
2. Barry.	8. Eaton.
3. Berrien.	9. Hillsdale.
4. Branch.	10. Ingham.
5. Calhoun.	11. Ionia.
6. Cass.	12. Jackson.

MICHIGAN—Continued

13. Kalamazoo.	19. Muskegon.
14. Kent.	20. Newaygo.
15. Lake.	21. Oceana.
16. Mason.	22. Ottawa.
17. Mecosta.	23. St. Joseph.
18. Montcalm.	24. Van Buren.

OHIO

1. Defiance.	4. Van Wert.
2. Mercer.	5. Williams.
3. Paulding.	

WISCONSIN

1. Adams.	18. Manitowoc.
2. Brown.	19. Marquette.
3. Calumet.	20. Milwaukee.
4. Columbia.	21. Outagamie.
5. Dane.	22. Ozaukee.
6. Dodge.	23. Racine.
7. Door.	24. Richland.
8. Fond du Lac.	25. Rock.
9. Grant.	26. Sauk.
10. Green.	27. Sheboygan.
11. Green Lake.	28. Walworth.
12. Iowa.	29. Washington.
13. Jefferson.	30. Waukesha.
14. Juneau.	31. Waupaca.
15. Kenosha.	32. Waushara.
16. Kewaunee.	33. Winnebago.
17. Lafayette.	

D. Part 89—Public Safety Radio Services:

1. In § 89.55, paragraph (b) is revised to read as follows:

§ 89.55 Filing of applications.

(b) Except for applicants in the Chicago, Ill., Regional Area filing on FCC Form 425, any application for radio station authorization and all correspondence relating thereto shall be submitted to the Commission's office at Washington, D.C. 20554, directed to the attention of the Secretary. Applicants for base, mobile, and fixed stations to operate on frequencies below 950 MHz in the Chicago Region shall file FCC Form 425 at the Commission's Washington, D.C., office until January 1, 1973; after January 1, 1973, the form is to be filed at the Commission's Chicago Regional Office. An application for commercial radio operator permit or license may be submitted to any of the Commission's engineering field offices, or to the Commission's office at Washington, D.C. 20554.

2. In § 89.59 the introductory text of paragraph (a) is amended to read as follows:

§ 89.59 Standard forms to be used.

(a) Except as provided in § 89.60 and in paragraph (h) of this section, a separate application shall be submitted on FCC Form 400 for the following:

E. Part 91—Industrial Radio Services:

1. In § 91.54, paragraph (b) is amended to read as follows:

§ 91.54 Filing of applications.

(b) Except for applicants in the Chicago, Ill., Regional Area filing on FCC Form 425, any application for radio station authorization and all correspondence relating thereto shall be submitted

to the Commission's office at Washington, D.C. 20554, directed to the attention of the Secretary. Applicants for base, mobile, and fixed stations to operate on frequencies below 950 MHz in the Chicago Region shall file FCC Form 425 at the Commission's Washington, D.C., office until January 1, 1973; after January 1, 1973, the form is to be filed at the Commission's Chicago Regional Office. An application for commercial radio operator permit or license may be submitted to any of the Commission's engineering field offices, or to the Commission's office at Washington, D.C. 20554.

2. In § 91.56 the introductory text of paragraph (a) is amended to read as follows:

91.56 Standard forms to be used.

(a) Except as provided in § 91.57 and in paragraph (h) of this section, a separate application shall be submitted on FCC Form 400 for the following:

F. Part 93—Land Transportation Radio Services:

1. In § 93.54, paragraph (b) is amended to read as follows:

§ 93.54 Filing of applications.

(b) Except for applicants in the Chicago, Ill., Regional Area filing on FCC Form 425, any application for radio station authorization and all correspondence relating thereto shall be submitted to the Commission's office at Washington, D.C. 20554, directed to the attention of the Secretary. Applicants for base, mobile, and fixed stations to operate on frequencies below 950 MHz in the Chicago Region shall file FCC Form 425 at the Commission's Washington, D.C., office until January 1, 1973; after January 1, 1973, the form is to be filed at the Commission's Chicago Regional Office. An application for commercial radio operator permit or license may be submitted to any of the Commission's engineering field offices, or to the Commission's office at Washington, D.C. 20554.

2. In § 93.56, the introductory text of paragraph (a) is amended to read as follows:

§ 93.56 Standard forms to be used.

(a) Except as provided in § 93.57 and in paragraph (h) of this section, a separate application shall be submitted on FCC Form 400 for the following:

3. New rules §§ 89.60, 91.57, and 93.57 are added to Parts 89, 91, and 93 to read identically as § 89.60 below:

§ 89.60 Use of FCC Form 425.

(a) Beginning April 1, 1973, separate applications on FCC Form 425 in lieu of Form 400 shall be submitted by the following persons:

(1) Applicants proposing to operate new base, mobile, and fixed stations on frequencies below 950 MHz (excluding

applications in the Industrial Radiolocation Service) in the Chicago, Ill., Regional Area defined in paragraph (b) of this section, and applicants proposing to modify, renew, or assign existing authorizations for such stations located in the Chicago Region. Such applications shall be submitted to the Commission's office at Washington, D.C. 20554, until January 1, 1973; after January 1, 1973, they shall be submitted to the Commission's Chicago Regional Office. The address of the Regional Office will be published at a later date.

(2) Applicants proposing to operate base, mobile, or fixed stations on frequencies in the band 470-512 MHz within 50 miles of the center of the following nine urbanized areas:

1. Boston, Mass.
2. Cleveland, Ohio.
3. Detroit, Mich.
4. Los Angeles, Calif.
5. New York-Northeast New Jersey.
6. Philadelphia, Pa.
7. Pittsburgh, Pa.
8. San Francisco-Oakland, Calif.
9. Washington, D.C.-Maryland-Virginia.

(b) The Chicago, Ill., Region is defined to consist of the counties listed below:

ILLINOIS

- | | |
|-----------------|------------------|
| 1. Boone. | 28. Livingston. |
| 2. Bureau. | 29. Logan. |
| 3. Carroll. | 30. Macon. |
| 4. Champaign. | 31. Marshall. |
| 5. Christian. | 32. Mason. |
| 6. Clark. | 33. McHenry. |
| 7. Coles. | 34. McLean. |
| 8. Cook. | 35. Menard. |
| 9. Cumberland. | 36. Mercer. |
| 10. De Kalb. | 37. Moultrie. |
| 11. De Witt. | 38. Ogle. |
| 12. Douglas. | 39. Peoria. |
| 13. Du Page. | 40. Piatt. |
| 14. Edgar. | 41. Putnam. |
| 15. Ford. | 42. Rock Island. |
| 16. Fulton. | 43. Sangamon. |
| 17. Grundy. | 44. Shelby. |
| 18. Henry. | 45. Stark. |
| 19. Iroquois. | 46. Stephenson. |
| 20. Jo Daviess. | 47. Tazewell. |
| 21. Kane. | 48. Vermillion. |
| 22. Kankakee. | 49. Warren. |
| 23. Kendall. | 50. Whiteside. |
| 24. Knox. | 51. Will. |
| 25. Lake. | 52. Winnebago. |
| 26. La Salle. | 53. Woodford. |
| 27. Lee. | |

INDIANA

- | | |
|-----------------|-----------------|
| 1. Adams. | 25. Lake. |
| 2. Allen. | 26. Lagrange. |
| 3. Benton. | 27. La Porte. |
| 4. Blackford. | 28. Madison. |
| 5. Boone. | 29. Marion. |
| 6. Carroll. | 30. Marshall. |
| 7. Cass. | 31. Miami. |
| 8. Clay. | 32. Montgomery. |
| 9. Clinton. | 33. Morgan. |
| 10. De Kalb. | 34. Newton. |
| 11. Delaware. | 35. Nobel. |
| 12. Elkhart. | 36. Owen. |
| 13. Fountain. | 37. Parke. |
| 14. Fulton. | 38. Porter. |
| 15. Grant. | 39. Pulaski. |
| 16. Hamilton. | 40. Putnam. |
| 17. Hancock. | 41. Randolph. |
| 18. Hendricks. | 42. St. Joseph. |
| 19. Henry. | 43. Starke. |
| 20. Howard. | 44. Steuben. |
| 21. Huntington. | 45. Tippecanoe. |
| 22. Jasper. | 46. Tipton. |
| 23. Jay. | 47. Vermillion. |
| 24. Kosciusko. | 48. Vigo. |

INDIANA—Continued

- | | |
|-------------|--------------|
| 49. Wabash. | 52. White. |
| 50. Warren. | 53. Whitley. |
| 51. Wells. | |

IOWA

- | | |
|-------------|---------------|
| 1. Cedar. | 5. Jones. |
| 2. Clinton. | 6. Muscatine. |
| 3. Dubuque. | 7. Scott. |
| 4. Jackson. | |

MICHIGAN

- | | |
|---------------|-----------------|
| 1. Allegan. | 13. Kalamazoo. |
| 2. Barry. | 14. Kent. |
| 3. Berrien. | 15. Lake. |
| 4. Branch. | 16. Mason. |
| 5. Calhoun. | 17. Mecosta. |
| 6. Cass. | 18. Montcalm. |
| 7. Clinton. | 19. Muskegon. |
| 8. Eaton. | 20. Newaygo. |
| 9. Hillsdale. | 21. Oceana. |
| 10. Ingham. | 22. Ottawa. |
| 11. Ionia. | 23. St. Joseph. |
| 12. Jackson. | 24. Van Buren. |

OHIO

- | | |
|--------------|--------------|
| 1. Defiance. | 4. Van Wert. |
| 2. Mercer. | 5. Williams. |
| 3. Paulding. | |

WISCONSIN

- | | |
|-----------------|-----------------|
| 1. Adams. | 18. Manitowoc. |
| 2. Brown. | 19. Marquette. |
| 3. Calumet. | 20. Milwaukee. |
| 4. Columbia. | 21. Outagamie. |
| 5. Dane. | 22. Ozaukee. |
| 6. Dodge. | 23. Racine. |
| 7. Door. | 24. Richland. |
| 8. Fond du Lac. | 25. Rock. |
| 9. Grant. | 26. Sauk. |
| 10. Green. | 27. Sheboygan. |
| 11. Green Lake. | 28. Walworth. |
| 12. Iowa. | 29. Washington. |
| 13. Jefferson. | 30. Waukesha. |
| 14. Juneau. | 31. Waupaca. |
| 15. Kenosha. | 32. Waushara. |
| 16. Kewaunee. | 33. Winnebago. |
| 17. Lafayette. | |

G. Part 95—Citizens Radio Service:

1. In § 95.15, paragraph (b) is amended, in part, to read as follows:

§ 95.15 Filing of applications.

(b) All formal applications for Class C or Class D new, modified, or renewal station authorizations and for Class B renewal station authorizations¹ shall be submitted to the Commission's office at 334 York Street, Gettysburg, PA 17325. Applications for Class A station authorizations, applications for consent to transfer of control of a corporation holding any citizens radio station authorization, requests for special temporary authority or other special requests and correspondence relating to an application for any class citizens radio station authorization shall be submitted to the Commission's Office at Washington, D.C. 20554, and should be directed to the attention of the Secretary. Beginning January 1, 1973, applicants for Class A stations in the Chicago Regional Area, defined in § 95.19, shall submit their applications to the Commission's Chicago Regional Office. The address of the Regional Office will be announced at a

¹ Effective Mar. 18, 1968, applications for new Class B station authorizations or modification of existing authorizations will not be accepted for filing.

later date. Applications involving Class A or Class D station equipment which is neither type approved nor crystal controlled, whether of commercial or home construction, shall be accompanied by supplemental data describing in detail the design and construction of the transmitter and methods employed in testing it to determine compliance with the technical requirements set forth in Subpart C of this part.

2. In § 95.19, the introductory text of paragraph (b) is amended and a new paragraph (d) is added to read as follows:

§ 95.19 Standard forms to be used.

(b) FCC Form 400, Application for Radio Station Authorization in the Safety and Special Radio Services: Except as provided in paragraph (d) of this section, this form shall be used when:

(d) Beginning April 1, 1972, FCC Form 425 shall be used in lieu of FCC Form 400, applicants for Class A stations located in the Chicago Regional Area defined to consist of the counties listed below:

ILLINOIS

- | | |
|-----------------|------------------|
| 1. Boone. | 28. Livingston. |
| 2. Bureau. | 29. Logan. |
| 3. Carroll. | 30. Macon. |
| 4. Champaign. | 31. Marshall. |
| 5. Christian. | 32. Mason. |
| 6. Clark. | 33. McHenry. |
| 7. Coles. | 34. McLean. |
| 8. Cook. | 35. Menard. |
| 9. Cumberland. | 36. Mercer. |
| 10. De Kalb. | 37. Moultrie. |
| 11. De Witt. | 38. Ogle. |
| 12. Douglas. | 39. Peoria. |
| 13. Du Page. | 40. Piatt. |
| 14. Edgar. | 41. Putnam. |
| 15. Ford. | 42. Rock Island. |
| 16. Fulton. | 43. Sangamon. |
| 17. Grundy. | 44. Shelby. |
| 18. Henry. | 45. Stark. |
| 19. Iroquois. | 46. Stephenson. |
| 20. Jo Daviess. | 47. Tazewell. |
| 21. Kane. | 48. Vermillion. |
| 22. Kankakee. | 49. Warren. |
| 23. Kendall. | 50. Whiteside. |
| 24. Knox. | 51. Will. |
| 25. Lake. | 52. Winnebago. |
| 26. La Salle. | 53. Woodford. |
| 27. Lee. | |

INDIANA

- | | |
|-----------------|-----------------|
| 1. Adams. | 22. Jasper. |
| 2. Allen. | 23. Jay. |
| 3. Benton. | 24. Kosciusko. |
| 4. Blackford. | 25. Lake. |
| 5. Boone. | 26. Lagrange. |
| 6. Carroll. | 27. La Porte. |
| 7. Cass. | 28. Madison. |
| 8. Clay. | 29. Marion. |
| 9. Clinton. | 30. Marshall. |
| 10. De Kalb. | 31. Miami. |
| 11. Delaware. | 32. Montgomery. |
| 12. Elkhart. | 33. Morgan. |
| 13. Fountain. | 34. Newton. |
| 14. Fulton. | 35. Noble. |
| 15. Grant. | 36. Owen. |
| 16. Hamilton. | 37. Parke. |
| 17. Hancock. | 38. Porter. |
| 18. Hendricks. | 39. Pulaski. |
| 19. Henry. | 40. Putnam. |
| 20. Howard. | 41. Randolph. |
| 21. Huntington. | 42. St. Joseph. |

RULES AND REGULATIONS

INDIANA—Continued

- | | |
|-----------------|--------------|
| 43. Starke. | 49. Wabash. |
| 44. Steuben. | 50. Warren. |
| 45. Tippecanoe. | 51. Wells. |
| 46. Tipton. | 52. White. |
| 47. Vermillion. | 53. Whitley. |
| 48. Vigo. | |

IOWA

- | | |
|-------------|---------------|
| 1. Cedar. | 5. Jones. |
| 2. Clinton. | 6. Muscatine. |
| 3. Dubuque. | 7. Scott. |
| 4. Jackson. | |

MICHIGAN

- | | |
|-------------|-------------|
| 1. Allegan. | 4. Branch. |
| 2. Barry. | 5. Calhoun. |
| 3. Berrien. | 6. Cass. |

MICHIGAN—Continued

- | | |
|----------------|-----------------|
| 7. Clinton. | 16. Mason. |
| 8. Eaton. | 17. Mecosta. |
| 9. Hillsdale. | 18. Montcalm. |
| 10. Ingham. | 19. Muskegon. |
| 11. Ionia. | 20. Newaygo. |
| 12. Jackson. | 21. Oceana. |
| 13. Kalamazoo. | 22. Ottawa. |
| 14. Kent. | 23. St. Joseph. |
| 15. Lake. | 24. Van Buren. |

OHIO

- | | |
|--------------|--------------|
| 1. Defiance. | 4. Van Wert. |
| 2. Mercer. | 5. Williams. |
| 3. Paulding. | |

WISCONSIN

- | | |
|-----------|--------------|
| 1. Adams. | 3. Calumet. |
| 2. Brown. | 4. Columbia. |

WISCONSIN—Continued

- | | |
|-----------------|-----------------|
| 5. Dane. | 20. Milwaukee. |
| 6. Dodge. | 21. Outagamie. |
| 7. Door. | 22. Ozaukee. |
| 8. Fond du Lac. | 23. Racine. |
| 9. Grant. | 24. Richland. |
| 10. Green. | 25. Rock. |
| 11. Green Lake. | 26. Sauk. |
| 12. Iowa. | 27. Sheboygan. |
| 13. Jefferson. | 28. Walworth. |
| 14. Juneau. | 29. Washington. |
| 15. Kenosha. | 30. Waukesha. |
| 16. Kewaunee. | 31. Waupaca. |
| 17. Lafayette. | 32. Waushara. |
| 18. Manitowoc. | 33. Winnebago. |
| 19. Marquette. | |

[FR Doc.71-16513 Filed 11-11-71;8:45 am]

Proposed Rule Making

DEPARTMENT OF AGRICULTURE

Packers and Stockyards Administration

[9 CFR Part 201]

LIVE POULTRY

Instructions on Weighing and Testing Scales Used in Purchase, Sale, or Acquisition

Notice is hereby given in accordance with administrative procedure provisions of 5 U.S.C. section 553 that pursuant to sections 402 and 407 of the Packers and Stockyards Acts, as amended (7 U.S.C., 222, 228), the Packers and Stockyards Administration is proposing to promulgate the following instructions for weighing live poultry and testing scales used for weighing live poultry.

The majority of all live poultry produced under contract or otherwise entering the marketing channel must be weighed for the purpose of arriving at the proceeds due the grower or seller. It is, therefore, important that all weighing facilities used in the marketing of poultry be accurate. This can only be assured through an adequate scale testing program. The testing shall be conducted by a competent agency in accordance with standards acceptable to the Department. It is also important that weighing procedures followed in the actual weighing process assure accurate weights.

The proposed instructions for testing vehicle scales used for weighing live poultry conform basically with the requirements for testing and accuracy recommended by the National Bureau of Standards and are in conformity with National Bureau of Standards Handbook 44, 3d edition, with amendments through July 31, 1971. This publication has been promulgated in whole or in part by 48 States. The instructions would implement and interpret §§ 201.105; 201.106; 201.107; 201.108; 201.109; 201.110 of the regulations which require that scales used for weighing live poultry be tested properly and operated by competent weighmasters.

§ 201.106-1 Instructions for testing vehicle scales used for weighing live poultry.

(a) *Adoption of National Bureau of Standards Codes in Handbook 44.* Insofar as they are applicable to vehicle scales, the specifications, tolerances, and other technical requirements for commercial weighing devices, as published in the National Bureau of Standards Handbook 44, 3d edition, with amendments through July 31, 1971, shall be applied to all vehicle scales under the supervision of the Packers and Stockyards Administration, except insofar as

different provisions are set forth in this § 201.106-1. In the following instructions, citations to corresponding paragraphs of Handbook 44 material appear in parenthesis:

(b) *Definitions.* (1) A vehicle scale is one adapted to weighing highway vehicles, loaded or unloaded. (S-D)

(2) A proper test is one which fully discloses the accuracy and other performance characteristics of the scale and all mechanisms and devices attached thereto under all conditions which may prevail during actual use. It includes the application of loads of standard test weights and tests of individual components such as fractional bars, poises, notches, dials, digital indicators, recording elements, unit weights and main levers or sections which independently may affect weighing accuracy; it demands a reasonably exact determination of the errors which develop; finally, it requires the recording in permanent form of all pertinent data developed during the test.

(3) A competent testing agency is one which employs experienced personnel and utilizes a sufficient amount of standard test weights to conduct tests in accordance with the procedure described in the instructions which follow. Agencies which the Administration considers competent on that basis include State and local weights and measures departments and commercial scale repair and service companies having adequate test equipment and employing qualified service personnel.

(4) A suitable interval between tests is a period of approximately 6 months. In instances where tests and inspections disclose that a scale does not maintain its accuracy between tests or is otherwise undependable, or is mechanically deficient as to construction, installation or maintenance, more frequent tests may be required.

(5) *Zero-load balance:* A correct weight indication or representation of zero when there is no load on the load-receiving element. (S-D)

(6) *Sensitivity response or SR:* The change in load required to change the position of rest of the indicating element or elements of a nonautomatic-indicating scale a definite amount at any load.

(7) *Increasing-load test:* The normal basic performance test for a scale in which observations are made as increments of test-weight load are successively added to the load-receiving element of the scale. (S-D)

(8) *Shift test:* A test intended to disclose the weighing performance of a scale under off-center loading. (S-D)

(9) *Decreasing-load test:* A special supplementary test for automatic-indicating scales only, during which the performance of the scale is tested when the load is being reduced. In this test, an

observation is made with the test weight load equal to one-half of the maximum applied test load. (S-D)

(10) *Strain-load test:* A test which involves the application of a relatively large load of unknown weight value as a "strain load" and then noting the increase in weight indication resulting from the application of available test-weight load.

(c) *Tests for sensitiveness (SR) for nonautomatic-indicating scale.* The test for sensitiveness shall be conducted on all nonautomatic-indicating scales. SR tests shall be made at zero load and at the maximum test load applied to the scale by either increasing or decreasing the test-weight load on the load-receiving element of the scale. The response of the scale shall be as follows:

(1) *On a scale with a trig loop but without a balance indicator.* The position of rest of the weighbeam shall change from the center of the trig loop to the top or bottom, as the case may be.

(2) *On a scale with a balance indicator.* The position of rest of a single indicator on a vehicle scale shall change at least 0.25 (¼) inch or the width of the central target area, whichever is greater.

(d) *SR requirements for vehicle scales.* (1) Application: The SR applicable to a scale is the same whether acceptance or maintenance tolerances apply. (SR.1)

(2) The SR on a scale not equipped with a balance indicator shall not exceed the value of two of the minimum graduated intervals on the weighbeam.

(3) The SR on a scale equipped with a balance indicator shall be the value of the minimum graduated interval on the weighbeam.

(e) *Tolerances.* (Applicable with respect to the performance or accuracy of vehicle scales). (G.T.)

(1) *Acceptance tolerances.* Acceptance tolerances shall apply as follows:

(i) To any equipment about to be put into commercial use for the first time.

(ii) To equipment that has been placed in commercial service within the preceding 30 days and is being officially tested for the first time.

(iii) To equipment that has been returned to commercial service following official rejection for failure to conform to performance requirements and is being officially tested for the first time within 30 days after corrective service.

(iv) To equipment that is being officially tested for the first time within 30 days after major reconditioning or overhaul. (1966, G.T.1)

(2) *Maintenance tolerances.* Maintenance tolerances shall apply to equipment in use, except as provided in subparagraph (1) of this paragraph. (G.T.2)

(3) *Tolerance applications—(i) To errors of underregistration and overregistration.* The tolerances hereinafter prescribed shall be applied equally to

errors of underregistration and errors of overregistration. (T.1.1)

(ii) *To scales with multiple elements.* Tolerances shall be applied independently to each indicating and recording element of a scale. However, the following requirements pertaining to analog and digital elements shall also apply:

(a) All analog indications within the same element shall not differ from one another and all digital elements shall not differ from one another.

(b) All analog indications and recorded representations shall not differ from digital indications and recorded representations by an amount greater than the value of the minimum graduated interval on the device except the elements shall not differ under a no-load zero balance condition.

(c) All components of the same element used in combination (such as a dial and unit weight) shall not differ by an amount greater than the applicable tolerance at a given test load. (T.1.2)

(iii) *To tests involving digital indications or representations.* To the tolerances that would otherwise be applied there shall be added an amount equal to one-half the minimum value that can be indicated or recorded. (T.1.3)

(iv) *To increasing-load tests.* Basic tolerances shall be applied. (T.1.5)

(v) *To shift tests.* Basic tolerances shall be applied. (T.1.4)

(vi) *To decreasing-load tests on automatic-indicating scales.* One and one-half (1.5) times basic tolerances shall be applied. (T.1.6)

(4) *Minimum tolerance values.* (The smallest tolerance that may be applied to a scale.) The minimum maintenance and acceptance tolerance applied to a vehicle scale shall be not smaller than one-half the value of the minimum graduated interval. (T.2)

(5) *Basic tolerance values.* (i) Application: Basic tolerance values shall be applied to weighbeam, reading face, and unit-weight indications and to recorded representations. (T.1)

(ii) The basic maintenance tolerance on vehicle scales shall be 2 pounds per 1,000 pounds of test load (0.2 percent). The acceptance tolerance shall be one-half the basic maintenance tolerance (0.1 percent). (T.3.5)

(f) *Suitability of equipment.* (1) Commercial equipment shall be suitable for the service in which it is used with respect to elements of its design, including, but not limited to, its weighing capacity, the character, number, size, and location of its indicating or recording elements and the value of its minimum graduated interval. (G.UR1.1)

(2) For vehicle scales: Vehicle scales shall be equipped with a type-registering weighbeam, a dial with a mechanical ticket printer, or similar device, such as a digital indicator with a printer, which shall be used for printing or stamping weight values on scale tickets. Automatic-indicating scales equipped with recording elements shall be designed to indicate and record weight values to the nearest minimum graduated interval.

(3) Value of minimum graduated intervals on primary indicating and recording elements: The value of the minimum graduated interval on vehicle scales shall be not greater than 20 pounds. (UR 1.1.6)

(4) Installation requirements:

(i) *General.* A device shall be installed in accordance with the manufacturer's instructions, including any instructions marked on the device. A vehicle scale shall be so installed that neither its operation nor its performance will be adversely affected by any characteristic of the foundation, supports, or any other detail of the installation. (G.UR 2.1)

(ii) *Protection against wind and weather effects.* The indicating elements, the lever system or load cells, and the under side of the load-receiving element of a vehicle scale shall be adequately protected against wind and weather effects. (UR 2.3)

(iii) *Foundation, supports, and clearance.* The foundation and supports of any vehicle scale shall be such as to provide strength, rigidity, and permanence of all components, and clearance shall be provided around all live parts to the extent that no contacts may result when the load-receiving element is empty and throughout the weighing range of the scale. (UR 2.4)

(iv) *Access to pit.* Adequate provision shall be made for ready access to the pit of a vehicle scale for purposes of inspection and maintenance. (UR 2.5)

(5) Maintenance requirements:

(i) *Maintenance of equipment.* All equipment in commercial service and all mechanisms and devices attached thereto or used in connection therewith shall continuously be maintained in proper operating condition throughout the period of such service. (G.UR 4.1)

(ii) *Use of adjustments.* Weighing elements that are adjustable shall be adjusted only to correct those conditions that such elements are designed to control and shall not be adjusted to compensate for defective or abnormal installation or accessories or for badly worn, or otherwise defective parts, of the assembly. Any faulty installation conditions shall be corrected, and any defective parts shall be renewed or suitably repaired, before adjustments are undertaken. Whenever equipment is adjusted, the adjustment shall be so made as to bring performance errors as close as practicable to zero value. (G.UR 4.2)

(iii) *Balance condition.* A scale shall be maintained in zero-load balance.

(iv) *Method of operation.* Equipment shall be operated only in the manner that is obviously indicated by its construction or that is indicated by instructions on the equipment. (G.UR 3.1)

(g) *Official inspection and test procedures for vehicle scales.* Vehicle scales shall be inspected and tested in accordance with the following procedures or such other procedures as may be approved by the Administrator in specific instances.

(1) *Inspection procedure.* Before the actual test of a vehicle scale is begun, a thorough visual inspection is to be made

of the scale installation. Adequate clearance must be maintained between the deck of the scale and the pit wall. The weighbeam shelf pillars and/or dial cabinet must be firmly anchored to a solid foundation. The scale platform shall be cleaned of debris and foreign matter which might adhere to the test weights or otherwise be removed during the test causing a change in the zero-load balance. No other change or cleaning may be performed since it is important for the scale to be tested "as found" if the results are to truly indicate characteristic weighing performance.

(2) *Test procedure—weighbeam scales—(i) Error determination.* The most precise method of determining the errors during the test of a vehicle scale equipped with a weighbeam is known as the error-weight procedure. This method is explained in the following paragraphs.

(ii) *Zero-load balance.* With all poises at zero, accurately balance the scale at zero with at least 50 pounds of small denomination weights on the platform. These error weights will be used to accurately measure errors and balance changes during the test.

(iii) *The SR (sensitivity response).* The SR value at zero load shall be determined by increasing or decreasing the amount of error weights on the platform until the appropriate change in the rest point of the weighbeam or balance indicator is obtained. On scales equipped with balance indicators a change in load equal to the minimum weighbeam graduation shall change the position of rest of the balance indicator 0.25 (1/4) inch or the width of the central target area, whichever is greater. On scales not equipped with a balance indicator a change in load not to exceed the value of two minimum weighbeam graduations shall move the weighbeam from a position of rest in the center of the trig loop to a position of rest either at the top or bottom of the trig loop.

(iv) *Increasing-load test.* (a) Shift or section test: A minimum of 10,000 pounds of standard test weights shall be used in conducting this test. An increasing-load test should be made with not less than two different test loads centered successively over each section of the lever system. At each test load applied increase or decrease the amount of error weights as required to produce a correct balance of the weighbeam or balance indicator. Any difference between the value of the error weights at zero load and at any given test load will represent the error at that particular test load. During this test, check the printed weight values for accuracy and legibility by operating the weight-recording device at representative loads. The fractional bar may also be tested at this time by comparison with the main bar or by a separate test of the fractional bar if sufficient small denomination test weights are available. After the sections have been tested, remove the test weights and check the zero-load balance carefully to determine the amount of balance change, if any. Any shift in the zero-load balance must be recorded. A new zero-load balance is then

obtained by increasing or decreasing the amount of error weights or by using the balance ball.

(b) *Strain-load test:* Next, the empty test truck is weighed with the rear axles centered successively as nearly as possible on each section of the scale and the weight value determined by the use of error weights and recorded for each section. The test weights are then loaded on the truck and the weight of the loaded truck determined on each section and recorded. In evaluating the strain-load test, any difference in the weight of the loaded truck and the weight of the empty truck, plus the test weights, is the amount of error. The appropriate tolerance is applied only to the amount of standard test weights used.

(c) The SR (sensitivity response) value at the full test load must now be determined as described in subdivision (iii) of this subparagraph.

(d) The truck is then removed from the scale and any zero-load balance shift determined by utilizing the error weights.

(e) Remove error weights and rebalance scale at zero load.

(3) *Test procedure—automatic-indicating scales.* (The testing procedure for automatic-indicating or dial scales corresponds basically to the procedure for testing weighbeam scales.)

(i) *Method of determining errors.* The use of error weights is also recommended when testing automatic-indicating scales. These error weights are used on scales equipped with automatic-weight recorders that will not print at dial capacity, or if overregistration is indicated at chart capacity without the application of a unit weight. This is also applicable on scales which are underregistering at zero when a unit weight is applied and when checking the zero-load balance. On all other weight determination made during the test, error weights are not removed or added since the actual printed weight determines the error.

(ii) *Section and strain-load test.* An increasing-load test and a strain-load test must be made with the test weights applied over each section of the scale as required in the test procedure for weighbeam scales.

(iii) *Dial and unit-weight test.* If sufficient test weights are available, automatic-indicating scales shall be tested at least at the four points representing each quarter of the reading face, and all unit weights normally used. This procedure has particular merit since it helps to determine if the errors developed during the test are in the dial, unit weight, or lever system.

(iv) *Zero-load balance.* After making the strain-load test, remove the truck from the scale platform and recheck the zero-load balance. Any balance shift at zero must be recorded. The error weights used to ascertain errors in the scale during the test are then removed and the scale restored to a correct zero-load balance.

(4) *Alternate test procedure—weighbeam and automatic-indicating scales.* Another accepted test procedure, which is approved by the Packers and Stock-

yards Administration, consists of conducting the increasing-load test by concentrating the known test load, within prescribed load limits, over each main load bearings of the scale. This procedure has considerable merit on scales having a nominal capacity greater than the total test load. The available test load is used to the greatest advantage by concentrating it over the main load bearings of the vehicle scale.

(5) *Test procedure—dual weighing installations.* Dual weighing systems usually consist of a weighbeam and dial connected to a single lever system and installed to function independently of each other. These installations are to be tested by observing and recording separately the performance of each unit. Such tests may be conducted and recorded simultaneously. Each unit is allowed appropriate tolerances, independently.

(h) *Record of test results.* (1) The results of each test must be recorded in full detail on official Form No. P&SA-216 provided by the Administration. (An exception may be made by the Administrator in the case of a State, county, or municipal agency which utilizes forms supplying substantially the same information as is provided for on the official Administration form. Essential information to be recorded includes:

(i) Identification of the scale by ownership, location, and address of the poultry processor or dealer using the scale, if different from the scale owner.

(ii) Identification and address of the scale testing agency and the signature of the local Administration representative present during the test.

(iii) Identification of the scale manufacturer, scale capacity, kind of weighbeam or other indicating elements, serial number, and the value of the minimum graduation on the weighbeam or indicating unit.

(iv) The identification of the balance indicator manufacturer, size of the scale platform, balance condition on arrival, the type of levers and pit depth.

(v) The date of the present test, date of the preceding test, and the year the scale was installed.

(vi) Data showing the SR at zero and capacity loads.

(vii) The test-load position, amount of test load applied and errors indicated or printed when conducting an increasing-load test.

(viii) The weight and position of the empty test truck, amount of test weights added, indicated weight of test truck and weights on each scale section and the error on the test weights added when conducting a strain-load test.

(2) At the conclusion of the test, the scale must be inspected thoroughly and any faulty condition of installation, construction, or maintenance which may affect the weighing performance recorded on the test report. There shall also be included on the report a record of any adjustments or repairs made at the time of test and of any recommen-

dations made for future repairs, maintenance, or replacements.

(3) The test results and other observations are to be recorded on the report under the proper headings as the test proceeds and immediately after observations are made. An original and at least two carbon copies of the report should be prepared. A copy of the test report must be forwarded to the area supervisor of the Packers and Stockyards Administration. One copy is for the scale owner, and one is for the scale testing agency.

§ 201.106-2 Instructions for testing scales other than vehicle scales used for weighing live poultry.

Scales other than vehicle scales used to weigh live poultry shall be inspected and tested in accordance with the examination procedure outlines of the National Bureau of Standards or such other procedures as may be approved by the Administrator in specific instances.

§ 201.108-1 Instructions for weighing live poultry.

Packers, live poultry dealers and handlers who operate scales on which live poultry is weighed for purposes of purchase, sale, acquisition, or settlement shall supply copies of the instructions in this section to all persons who perform weighing operations for them and direct such persons to familiarize themselves with the instructions and to comply with them at all times. This section shall also apply to any additional weighers who are employed at any time. The following instructions shall be applicable to the weighing of live poultry on all scales except paragraph (c)(1) of this section which is only applicable to the weighing of live poultry on vehicle scales.

(a) *Balancing the empty scale.* (1) The scale shall be maintained in zero balance at all times. The empty scale shall be balanced each day before weighing begins and thereafter its zero balance shall be verified before any poultry is weighed. In addition, the zero balance of the scale shall be verified whenever a weigher resumes weighing duties after an absence from the scale.

(2) Before balancing the empty scale, the weigher shall notify parties outside the scale house of his intention and shall assure himself that no persons or vehicles are in contact with the platform. When the empty scale is balanced and ready for weighing, he shall so indicate by appropriate signal.

(3) Weighbeam scales shall be balanced by first seating each poise securely in its zero notch and then moving the balance ball to such position that a correct zero balance is obtained. A scale equipped with a balance indicator is correctly balanced when the indicator comes to rest in the center of the target area. A scale not equipped with a balance indicator is correctly balanced if the weighbeam, when released at the top or bottom of the trig loop, swings freely in the trig loop in such manner that it will come to rest at the center of the trig loop.

(4) Dial scales shall be balanced by releasing all drop weights and operating

the balance ball or other balancing device to obtain a correct zero balance. The indicator must visibly indicate zero on the dial reading face and the ticket printer must record a correct zero balance. "Balance tickets" shall be filed with other scale tickets issued on that date.

(5) A balance ball or other balancing device shall be operated only when balancing the empty scale and shall not be operated at any other time or for any other purpose.

(6) The time at which the empty scale is balanced or its zero balance verified shall be marked on scale tickets or other permanent records.

(b) *Sensitivity control.* (1) A scale must be sensitive in response to platform loading if it is to yield accurate weights. It, therefore, is the duty of a weigher to assure himself that interferences, weighbeam friction, or other factors do not impair sensitivity. He shall satisfy himself, at least twice each day, that the scale is sufficiently sensitive, and, if the following requirements are not met, he must report the facts to his superior or employer immediately.

(2) A weighbeam scale with a balance indicator is sufficiently sensitive if, when the scale is balanced with the indicator at the center of the target, movement of the fractional poise one graduation will change the indicator rest point ($\frac{1}{4}$) inch (0.25) or the width of the central target area, whichever is greater.

(3) A weighbeam scale without a balance indicator is sufficiently sensitive if, when the scale is balanced with the weighbeam at the center of the trig loop, movement of the fractional poise two graduations will cause the weighbeam to come to rest at the bottom of the trig loop.

(4) Adjustable damping devices are incorporated in balance indicators and in dial scales to absorb the effects of load impact and to bring the indicator to rest. The weigher must be familiar with the location and adjustment of these damping devices and keep them so adjusted that when the indicator is displaced from a position of rest, it will oscillate freely through at least one complete cycle of movement before coming to rest at its original position.

(5) Friction at weighbeam bearings may reduce the sensitiveness of the scale, cause sluggish weighbeam action and affect weighing accuracy. A weigher must inspect the weighbeam assembly daily to make certain that there is clearance between the weighbeam and the pivot bearings.

(6) Interferences or binding of the scale platform, or other "live" parts of the scale, are common causes of weighing inaccuracy. A weigher shall satisfy himself, at the beginning of each weighing period, that all such "live" parts have sufficient clearance to prevent interference.

(c) *Weighing the load.* (1) Vehicle scales used to weigh live poultry shall be of sufficient length and capacity to weigh an entire vehicle as a unit: *Provided*, That a trailer may be uncoupled from a tractor and weighed as a single unit. Before weighing a vehicle, either coupled

or uncoupled, the weigher shall assure himself that the entire vehicle is on the scale platform and that no persons are on the scale platform.

(i) On a weighbeam scale with a balance indicator the weight of a vehicle shall be determined by moving the poises to such positions that the indicator will come to rest within the central target area.

(ii) On a weighbeam scale without a balance indicator the weight shall be determined by moving the poises to such positions that the weighbeam, when released from the top or bottom of the trig loop, will swing freely in the trig loop and come to rest at the approximate center of the trig loop.

(iii) On a dial scale the weight of a vehicle is indicated automatically when the indicator revolves around the dial face and comes to rest.

(2) The correct weight is the value in pounds indicated by a weighbeam or dial when correct load balance is obtained. In any case the weigher should concentrate his attention upon the beam tip, balance indicator or dial indicator while weighing and not concern himself with reading the visible weight indications until correct load balance is obtained.

(d) *Recording the weight.* (1) The gross or tare weight shall be recorded immediately after the load balance is obtained and before any poises are moved or load removed from the scale platform. The weigher shall make certain that the printed weight record agrees with the weight value visibly indicated on the weighbeam or dial when correct load balance is obtained. He shall also assure himself that the printed weight value is sufficiently distinct and legible.

(2) The weight printing device on a scale shall be operated only to produce a printed or impressed record of weight while the load is on the scale and correctly balanced. If the weight is not printed clearly and correctly, the ticket shall be marked void and a new one printed before the load is removed from the scale.

(e) *Weigher's responsibilities.* (1) The primary responsibility of a weigher is to determine and record the true weight of live poultry without prejudice or favor to any person or agency and without regard for poultry ownership, price, condition, shrink, or other considerations. A weigher shall not permit the representations or attitudes of any persons or agencies to influence his judgment or action in performing his duties.

(2) Unused scale tickets or those which are partially executed shall not be left exposed or accessible to other parties. All such tickets shall be kept under lock when the weigher is not at his duty station.

(3) Accurate weighing and weight recording require that a weigher shall not permit his operations to be hurried to the extent that inaccurate weights or incorrect weight records may result. The gross, tare and net weights must be determined accurately to the nearest minimum graduation. Manual operations connected with balancing, weighing, and recording

shall be performed with the care necessary to prevent damage to the accurately machined and adjusted parts of weighbeams, poises, and printing devices. Rough handling of these parts shall be avoided.

(4) Poultry growers, sellers, packers, dealers, and handlers, or others having legitimate interest in a load of poultry are entitled to observe the balancing, weighing, and recording procedures. A weigher shall not deny that right or withhold from them any information pertaining to the weight. He shall check the zero balance of the scale or reweigh a load of poultry when requested by such parties or duly authorized representatives of the Administrator.

(f) *General precautions.* (1) The poises of weighbeam scales are carefully adjusted and sealed to a definite weight at the factory and any change in that weight seriously affects weighing accuracy. A weigher, therefore, shall observe if poise parts are broken, loose or lost or if material is added to a poise and shall report any such condition to his superior or employer. Balancing or weighing shall not be performed while a scale ticket is in the slot of a weighbeam poise.

(2) Stops are provided on scale weighbeams to prevent movement of poises back of the zero graduation when balancing or weighing. When the stops become worn or broken and allow a poise to be set behind the zero position, this condition must be reported by the weigher to his superior or employer and corrected without delay.

(3) Foreign objects or loose material in the form of nuts, bolts, washers, or other material on any part of the weighbeam assembly, including the counter-balance hanger or counter-balance weights, are potential sources of weighing error. Loose balancing material must be enclosed in the shot cup of the counter-balance hanger and counter-balance weights must not be of the slotted type which can readily be removed.

(4) Whenever, for any reason, a weigher has reason to believe that a scale is not functioning properly or not yielding correct weight values, he shall discontinue weighing, report the facts to the parties responsible for scale maintenance and request inspection, test or repair of the scale.

(5) When a scale has been adjusted, modified, or repaired in any manner which can affect the accuracy of weighing or weight recording, the weigher shall not use the scale until it has been tested and inspected and found to be accurate.

Any person who wishes to submit written data, views, or arguments concerning the proposed instructions may do so by filing them in duplicate with the Hearing Clerk, U.S. Department of Agriculture, Washington, D.C. 20250, within 60 days from the publication of this notice in the FEDERAL REGISTER. All written submissions made pursuant to this notice will be made available for public inspection at such times and places and in a manner convenient to the public business (7 CFR 1.27(b)).

Done at Washington, D.C., this 5th day of November 1971.

ODIN LANGEN,
Administrator, Packers
and Stockyards Administration.

[FR Doc. 71-16589 Filed 11-11-71; 8:51 am]

DEPARTMENT OF LABOR

Occupational Safety and Health
Administration

[29 CFR Part 1904]

RECORDING AND REPORTING OCCUPATIONAL INJURIES AND ILLNESSES

Use of Data-Processing Equipment; Additional Time for Completing Forms; Posting of Annual Summary

Part 1904 of Title 29, Code of Federal Regulations, was established on July 2, 1971 (36 F.R. 8693). Since that date the Department of Labor has received a number of petitions for recordkeeping exceptions. Many petitions concerned the following two particular situations:

(1) Employers with many small establishments wish to have the required records prepared in a central place; and (2) employers with large establishments or many establishments, or both, believe that the required records would be more efficiently maintained through use of data-processing equipment. Proposals to afford the requested relief are set forth below. In addition, other proposals are set forth which would provide additional time for making record entries and which would provide for a specific period for posting the annual summary of occupational injuries and illnesses. Pursuant to sections 8(c) (1), (2), 8(g) (2), and 24 (e) (84 Stat. 1599, 1600, 1615; 29 U.S.C. 657, 673), and Secretary of Labor's Order No. 12-71 (36 F.R. 8754), it is proposed to amend Part 1904 of Title 29, Code of Federal Regulations, in the manner set forth below.

Interested persons are invited to submit written data, views, and comments concerning the proposed amendments. Such written matter may be mailed to the Assistant Secretary for Occupational Safety and Health, Department of Labor, 14th Street and Constitution Avenue NW., Washington, DC 20210, within 30 days after the publication of this notice in the FEDERAL REGISTER.

Also written submissions made pursuant to this notice will be made available for public inspection at the Office of Occupational Safety and Health Statistics, Bureau of Labor Statistics, U.S. Department of Labor, 441 G Street NW., Room 3818, Washington, DC 20212, except where the person making the submission requests that the submission be considered confidential and the Commissioner of BLS determines that the making of the submission public would disclose trade secrets, or other processes or operations which are privileged or confidential.

1. Section 1904.2 would be amended as follows:

§ 1904.2 Log of occupational injuries and illnesses.

(a) Each employer shall maintain in each establishment a log of all recordable occupational injuries and illnesses, except that under the circumstances described in paragraph (b) of this section an employer may maintain the log of occupational injuries and illnesses at a place other than the establishment. Each employer shall enter each recordable occupational injury and illness on the log within 6 working days after receiving information that a recordable case has occurred. For this purpose, Occupational Safety and Health Administration OSHA Form No. 100 or any private equivalent may be used. OSHA Form No. 100 or its equivalent shall be completed in the detail provided in the form and the instruction contained in OSHA Form No. 100. If an equivalent to OSHA Form No. 100 is used, such as a printout from data-processing equipment, the information shall be as readable and comprehensible to a person not familiar with the data-processing equipment as the OSHA Form No. 100 itself.

(b) Any employer may maintain the log of occupational injuries and illnesses at a place other than the establishment under the following circumstances:

(1) There is available at the place where the log is maintained sufficient information to complete the log to a date within 6 working days after a recordable case has occurred, as required by paragraph (a) of this section.

(2) A copy of the log, complete and current to a date within 45 calendar days, is available at each of the employer's establishments.

2. Section 1904.4 would be amended to read as follows:

§ 1904.4 Supplementary record.

In addition to the log of occupational injuries and illnesses provided for under § 1904.2, each employer shall have available for inspection at each establishment within 6 working days from the occurrence of a recordable case, a supplementary record for each occupational injury or illness. The record shall be completed in the detail prescribed in the instructions accompanying Occupational Safety and Health Administration Form OSHA No. 101. Workmen's compensation, insurance, or other reports are acceptable alternative records if they contain the information required by Form OSHA No. 101. If no acceptable alternative record is maintained for other purposes, Form OSHA No. 101 shall be used or the necessary information shall be otherwise maintained.

3. Section 1904.5 would be amended to read as follows:

§ 1904.5 Annual summary.

(a) Each employer shall compile an annual summary of occupational injuries and illnesses for each establishment. Each annual summary shall be based on the information contained in the log of occupational injuries and illnesses for the particular establishment. Form OSHA No. 102 shall be used for this purpose,

and shall be completed in the form and detail as provided in the instructions contained therein.

(b) The summary shall be completed no later than 1 month after the close of each calendar year beginning with calendar year 1971.

(c) Each employer, or the officer or employee of the employer who supervises the preparation of the annual summary of occupational injuries and illnesses, shall certify that the annual summary of occupational injuries and illnesses is true and complete. The certification shall be accomplished by affixing the signature of the employer, or the officer or employee of the employer who supervises the preparation of the annual summary of occupational injuries and illnesses, to the lower right hand corner of the annual summary or by appending a separate statement to the annual summary certifying that the annual summary is true and complete.

(d) (1) Each employer shall post a copy of the establishment's summary in each establishment in the same manner that notices are required to be posted under § 1903.2(a) of this chapter. The summary shall be posted no later than February 1 and shall remain in place for 30 calendar consecutive days thereafter.

(2) A failure to post a copy of the establishment's annual summary may result in the issuance of citations and assessment of penalties pursuant to sections 9 and 17 of the Act.

4. Section 1904.9 would be amended as follows:

§ 1904.9 Falsification, or failure to keep records or reports.

(a) Section 17(g) of the Act provides that "Whoever knowingly makes any false statement, representation, or certification in any application, record, report, plan or other document filed or required to be maintained pursuant to this Act shall, upon conviction, be punished by a fine of not more than \$10,000, or by imprisonment, for not more than 6 months or both."

(b) Failure to maintain records or file reports required by this part, or in the details required by forms and instructions issued under this part, may result in the issuance of citations and assessment of penalties as provided for in sections 9, 10, and 17 of the Act.

5. Section 1904.13 would be amended to read as follows:

§ 1904.13 Petitions for recordkeeping exceptions.

(a) *Submission of petition.* Any employer who wishes to maintain records in a manner different from that required by this part may submit a petition containing the information specified in paragraph (c) of this section to the Regional Director of the Bureau of Labor Statistics wherein the establishment involved is located.

(c) *Contents of petition.* A petition filed under paragraph (a) of this section shall include:

(1) The name and address of the applicant;

(2) The address of the place or places of employment involved;

(3) Specifications of the reasons for seeking relief;

(4) A description of the different recordkeeping procedures which are proposed by the applicant;

(5) A statement that the applicant has informed his affected employees of the petition by giving a copy thereof to them or to their authorized representative and by posting a statement giving a summary of the petition and by other appropriate means. A statement posted pursuant to this subparagraph shall be posted in each establishment in the same manner that notices are required to be posted under § 1903.2(a) of this chapter. The applicant shall also state that he has informed his affected employees of their rights under paragraph (b) of this section;

(6) In the event an employer has more than one establishment he shall submit a list of the States in which such establishments are located and the number of establishments in each such State. In the further event that certain of the employer's establishments would not be affected by the petition, the employer shall identify every establishment which would be affected by the petition and give the State in which they are located.

(Secs. 8(c), 8(g), 24, 84 Stat. 1599, 1600, 1615; 29 U.S.C. 657, 673; Secretary's Order No. 12-71, 36 F.R. 8754)

Signed at Washington, D.C. this 9th day of November 1971.

GEOFFREY H. MOORE,
Commissioner,
Bureau of Labor Statistics.

G. C. GUENTHER,
Assistant Secretary of Labor.

[FR Doc. 71-16584 Filed 11-11-71; 8:51 am]

DEPARTMENT OF HEALTH, EDUCATION, AND WELFARE

Food and Drug Administration

[21 CFR Part 3]

MANUFACTURE AND PROCESSING OF CANNED FOODS

Proposed Statement of Policy

Notice is given that a petition has been filed by the National Cannery Association, 1133 20th Street NW., Washington, DC 20036, proposing that the following statement of policy, accompanied by index and appendix, be published for comment. The proposal relates to commercially processed foods for human consumption manufactured, processed, or packed in hermetically sealed containers which are processed by heat either before or after being sealed in the container.

STATEMENT OF POLICY

APPLICATION OF EMERGENCY PERMIT PROVISIONS OF SECTION 404 OF THE FEDERAL FOOD, DRUG, AND COSMETIC ACT, AS AMENDED

§ 3. Commercial processing of foods in hermetically sealed containers.

(a) Inadequate processing of low-acid foods in hermetically sealed containers may result in the distribution in interstate commerce of processed foods that may be injurious to health and such injurious nature may not always be adequately determinable after those foods have entered into interstate commerce. The Commissioner of Food and Drugs therefore finds that the use of inadequate processing procedures for this class of foods may necessitate the institution in appropriate circumstances of emergency permit control under section 404 of the Federal Food, Drug, and Cosmetic Act, as amended. The Commissioner has determined that the failure of any commercial processor of low-acid foods in hermetically sealed containers, in any establishment, to fulfill all of the requirements of this section, which are intended to insure safe processing procedures and to permit the Food and Drug Administration to verify that these procedures are being followed, shall constitute a prima facie basis for the immediate application of the emergency permit control provisions of section 404 to that establishment. The Commissioner further finds that the implementation of this section and the enforcement of section 404 of the Federal Food, Drug, and Cosmetic Act, as amended, within the resources available to the Food and Drug Administration, require that paragraphs (c) and (d) of this section, relating to the registration of commercial processing establishments and required coding, be applicable to all processed foods in hermetically sealed containers. The failure of any commercial processor of these products to fulfill any such requirement shall likewise constitute a prima facie basis for the immediate application of the emergency permit control provisions of section 404 to the particular establishment.

(b) For the purposes of this section:

(1) "Commercial processor" shall include any person, as defined in section 201(e) of the Act, engaged in commercial, custom, and so-called sportsman processing or institutional (church, school, penal, or other organization) processing of food for human consumption.

(2) "Commercially processed food manufactured, processed, or packed" shall include all foods for human consumption in hermetically sealed containers which are processed by heat either before or after being sealed in the container to protect the health of the consumer.

(3) "Container" shall include cans, jars, pouches, barrels, or any other type of processed food container which is hermetically sealed and the contents of

which are processed by heat either before or after being sealed in the container.

(4) "Low-acid foods" means any food with finished equilibrium pH value greater than 4.6, and shall also include any food in which for the purpose of processing the pH value is reduced by acidification.

(c) Every person first engaging in the commercial manufacture, processing, or packing of any processed food in any State, as defined in section 201(a)(1) of the Act, shall not later than ten (10) days after first so engaging register with the Food and Drug Administration his name, principal place of business, and the location of each establishment in which such processing is carried on. Every person presently so engaged shall not later than sixty (60) days from the effective date of this section similarly register. Every person duly registered in accordance with this section shall not later than ten (10) days following the commencement of operations register with the Food and Drug Administration any additional establishments which he owns or operates in any State at which he begins the commercial manufacture, processing, or packing of processed foods. Every person duly registered in accordance with this section shall notify the Food and Drug Administration not later than ninety (90) days after such person ceases or discontinues the commercial manufacture, processing, or packing of processed foods in any establishment. *Provided*, That such notification shall not be required as to the temporary cessation in accordance with the seasonal character of the particular establishment's production.

(d) Every commercially processed food manufactured, processed, or packed in an establishment registered pursuant to this section shall be marked with an identifying code, which shall be permanently indicated on each food container by embossing, inking, or label perforation, so as to provide in code adequate indication of the establishment and the date of processing.

(e) The processing of low-acid foods shall be subject to the following additional requirements:

(1) Every person engaged in the commercial processing of low-acid foods who registers under paragraph (c) of this section shall, at the time of registration, file with the Food and Drug Administration on forms specified by the Commissioner (i) a list of the low-acid foods commercially manufactured, processed, or packed in each establishment, and (ii) such further information as to the equipment to be employed in the processing of each such low-acid food, as is specified in Appendix A.

(2) Every person engaged in the commercial processing of low-acid foods in any registered establishment shall not later than sixty (60) days after the effective date of this section, or as to seasonal operations prior to commencing such processing, file, on the forms specified in Appendix A (with the Food and

Drug Administration, the processes to be employed, specifying the retort equipment, minimum initial temperature, time, and temperature of processing for each such low-acid food in each container size.

(3) Every person engaged in the processing of low-acid foods in any registered establishment shall process each low-acid food in each container size in accordance with the procedures and processes filed in accordance with subparagraph (2) of this paragraph.

(4) Low-acid foods shall be coded in accordance with paragraph (d) of this section and the period code shall be changed every four (4) hours or less. The processing records covering all low-acid foods, including the coding applied, shall be retained for five (5) years.

(5) Whenever any inadvertent under-processing of any low-acid food is disclosed from processing records, by processor check or otherwise, the commercial processor of such low-acid food shall set aside the lot or lots involved for further evaluation as to any potential health significance of such under-processing, and upon completion of such evaluation and any determination that no potential health significance has resulted, shall report to the Food and Drug Administration that determination, and the basis for it, not less than ten (10) days in advance of any distribution of the whole or any part of any lot involved.

(6) Irrespective of any under-processing disclosed by processing records, every commercial processor of any low-acid food shall, in accordance with present industry practice, promptly report to the Food and Drug Administration all instances of spoilage having a potential health significance where any lot has in whole or in part entered distribution.

(7) Upon demand by any duly authorized employee of the Food and Drug Administration, every person commercially manufacturing, processing, or packing low-acid foods shall permit the inspection and copying by such employee of the processing records specified in Appendix A, to verify that adequate processing and coding of each such low-acid food was performed.

(8) All retort equipment used for the commercial processing of low-acid food shall, not later than ninety (90) days after the effective date of this section, or as to seasonal operations prior to beginning date of processing thereafter, be equipped with appropriate temperature recording devices.

(9) All retorts used in the commercial manufacture, processing, or packing of low-acid foods shall be operated at all times, and all can seam inspectors performing the can seam inspections for low-acid foods prescribed in Appendix A shall function, under the direct personal supervision of a person who has attended a certified school for retort operators or can seam inspectors, as the case may be, and has been certified by that school as having satisfactorily completed the

prescribed course of instruction in retort operation or can seam inspection: *Provided*, That this requirement shall not apply for a period of 1 year to the present operators of retorts and can seam inspectors in establishments registered pursuant to this section. The Commissioner will issue in the near future lists of approved schools for retort operators and for can seam inspectors qualified to certify such operators and inspectors as having satisfactorily completed the prescribed courses of instruction in retort operation and can seam inspection.

(10) Any data, report, or other information supplied by any commercial processor pursuant to subparagraphs (5), (6), and (7) of this paragraph (e) will not be used directly or indirectly as evidence in any criminal prosecution under the Federal Food, Drug, and Cosmetic Act of the person from whom obtained.

(f) Wherever any State regulates the commercial processing of low-acid foods, in accordance with effective regulations specifying at least the requirements of paragraph (e) of this section, compliance with such State regulations shall constitute compliance with paragraph (e) of this section. All other provisions of this section shall be applicable to the commercial processing of foods in such State.

(g) This section shall not apply to the commercial processing of any food processed under the continuous inspection of the Meat Inspection Service or the Poultry Inspection Service of the Consumer and Marketing Service of the Department of Agriculture under the Federal Meat Inspection Act (Public Law 90-201, 81 Stat. 584, 21 U.S.C. Section 601 et seq.) and the Poultry Products Inspection Act (Public Law 90-492, 82 Stat. 791, 21 U.S.C. Section 451 et seq.).

INDEX TO APPENDIX A		
Sec.		Page
1.1	Definitions	1
1.2	Coding of containers.....	2
1.3	Filing with FDA of processes to be employed for low-acid foods....	2
1.4	Acidification	4
1.5	Processing and production records	4
1.6	Examination of container closures	5
1.7	Retort room operations.....	8
1.8	Still retorts.....	9
	(a) Definitions	9
	(b) Equipment and installation for pressure processing in steam in still retorts.....	9
	(c) Equipment and installation for pressure processing in water in still retorts.....	19
1.9	Continuous agitating cookers.....	26
	(a) Definition	26
	(b) Equipment and installation for pressure processing in steam	27
	(c) Critical factors involved in this processing method.....	28
1.10	Discontinuous agitating cookers..	29
	(a) Definition	29
	(b) Equipment and installation for pressure processing in steam	29
	(c) Equipment and installation for pressure processing in water	32

Sec.	
1.11	Hydrostatic cookers..... 33
	(a) Definition
	(b) Equipment and installation for pressure processing in steam
1.12	Aseptic canning systems..... 36
	(a) Definition
	(b) Equipment for product pre-sterilization
	(c) Operation
1.13	Flame sterilizers..... 38
	(a) Definition
	(b) Operating conditions.....
1.14	New processing systems for processing low-acid foods..... 39
1.15	Cooling requirements..... 39

APPENDIX A

SECTION 1.1 Definitions.

(a) "Low-acid foods" means any food with a finished equilibrium pH value greater than 4.6 and shall also include any food in which for the purpose of processing the pH value is reduced by acidification.

(b) "Hermetically-sealed container" means a container which is secure against the entrance to, or escape from, the container of air, gases, or liquids, at any point of closure, seams or other area of the container surface.

(c) "Initial temperature" means the average temperature of the contents of the coldest product to be processed at the time the sterilization cycle begins, as determined after thorough stirring or shaking.

(d) "Commercial sterility" means the condition achieved by application of heat which renders the food free of viable forms of microorganisms having public health significance, as well as more heat resistant microorganisms of nonhealth significance capable of reproducing under normal conditions of storage and distribution.

(e) "Process" means the application of heat to food in containers, either before or after sealing, for a period of time and at a temperature scientifically determined to be adequate to achieve commercial sterility.

(f) "Retort" or "cooker" means any enclosed vessel or other machinery used for heat processing canned foods.

(g) "Vents" mean 1 inch or larger, gate, plug cock, or other valve controlled openings in retorts used for elimination of air during the venting period as required to achieve the processing temperature.

Sec. 1.2 Coding of containers.

(a) Each container of low-acid food manufactured, processed, or packed in any registered establishment shall be marked with an identifying code which shall be permanently indicated on the cover, or other visible surface, of each can, jar, pouch, barrel, or other container. When the container does not permit the code to be embossed or ink stamped thereon, it will be permissible to legibly perforate, or ink stamp the required code on the label, provided the label is securely affixed to the product container.

(b) The required indication to be affixed to each container shall identify in code the establishment where packed, the product contained therein, the year packed, the day packed, and the period of the day packed. The packing period code shall be changed every 4 hours or less.

Sec. 1.3 Filing with FDA of processes to be employed for low-acid foods.

(a) Every person engaged in the commercial processing of low-acid foods in any registered establishment shall not later than sixty (60) days after registration, or as to seasonal operations prior to commencing such processing, file, on the following or similar, forms with the Food and Drug Administration, the processes to be employed, specifying the processing method, minimum initial temperature, time, and temperature of

(2) The results of the tear-down examinations shall be recorded.

(3) Required and optional can seam measurements:

- (1) Micrometer measurement system.
 - Required: Cover hook, Body hook, Width (length, height), Tightness (observation for wrinkle), Thickness.
 - Optional: Overlap (by calculation), Countersink.
- (4) Two measurements shall be made for each double seam characteristic if a seam scope or seam projector is used. If a microscope is used, three measurements shall be made at points approximately 120° apart, excluding the side seam.
- (5) Can double seam terminology.

DOUBLE SEAM TERMINOLOGY

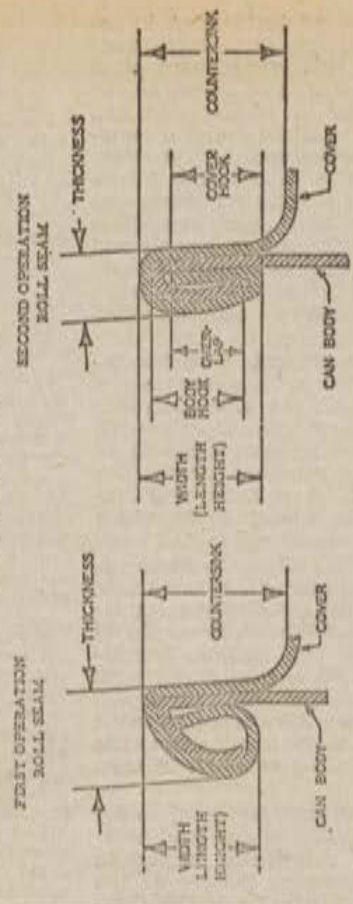

Minimum measurements
Width: (not essential if overlap is measured optically).
Thickness: (required for micrometer measurement).
Countersink (desirable but not essential).
Body hook.¹
Cover hook.² (required if micrometer is used).

Overlap: (essential if optical system used).
Tightness: or wrinkle.

Essential requirements.

(6) With regard to measurement limits, the processor shall follow the working limits recommended by the can and/or closing machine supplier.

(7) Overlap length can be calculated by the following formula: The theoretical overlap length = CH + BH + T - W where

CH = cover hook
BH = body hook
T = cover thickness, and
W = seam width (height, length)

¹In general practice, 0.010 may be used for the template thickness.

processing, and source of process for each such low-acid food in each container size, provided that the filling of such information, or the failure of the Food and Drug Administration method.

Product and product form	Container type and size (dimensions)	Minimum initial temp.	Process	Time: temp.	Source of process

¹ Note: For retorting processes include rotational speed and/or speed in cans per minute, minimum headspace, and in the case of thickened products, maximum product consistency.

(c) Each low-acid food in each container size shall be processed in accordance with the method and for at least the minimum times and temperatures filed in accordance with subsection 1.3(a) above.

Sec. 1.4 Acidification.

In instances in which products must be acidified sufficiently to permit safe processing at low temperatures, such as in boiling water, there shall be careful supervision to insure that the finished product equilibrium pH does not exceed the specified maximum as filed under section 1.3(b).

Sec. 1.5 Processing and production records.

(a) All processors of low-acid canned foods shall maintain the record specified herein and in other sections of this appendix.
(b) Daily processing and production information shall be entered by the retort operator on record forms which shall include the product, the code number, retort number, the size of container in each code, the approximate number of containers, and the initial temperature, processing time and temperature (time steam on; time temperature up; time steam off; and thermometer readings). The recording thermometer chart shall be identifiable with the lots processed.
(c) Each entry on the record shall be made by the retort operator at the time the specific retort condition or operation occurs and the retort operator shall sign each record form.
(d) A qualified representative of plant management shall review all processing and production records for adequacy not later than 1 working day after the actual process occurred and before the product is shipped. This management representative shall affix his or her signature to the records including the recording thermometer chart.

(e) All pertinent observations shall be recorded. If irregularities are found, the corrective action taken shall be noted.

(b) Tear-down examinations for cans. (1)

Tear-down examinations shall be made at a frequency of at least one can per seaming station every 4 hours of operation. Such examinations shall be made as soon as possible after starting up following prolonged shutdown, waiting only long enough for the machine to "warm up."

(2) The operator, closure supervisor, or other qualified container closure inspection personnel shall visually examine, at intervals of not more than 30 minutes, the top seam of a randomly selected can from each seaming head, or the closure of the container being used, and shall record his observations. Additional visual closure inspections shall be made immediately following a jam in a closure machine, or after startup of a machine following a prolonged shutdown.

(3) All pertinent observations shall be recorded. If irregularities are found, the corrective action taken shall be noted.

(b) Tear-down examinations for cans. (1)

Tear-down examinations shall be made at a frequency of at least one can per seaming station every 4 hours of operation. Such examinations shall be made as soon as possible after starting up following prolonged shutdown, waiting only long enough for the machine to "warm up."

- (c) *Records.* (1) Written records shall be made on all seam examinations.
- (2) The records shall show the date and time of visual and teardown inspections, and the measurements made.
- (3) The records of seam inspection shall be retained for a period of not less than two (2) years.

Sec. 1.7 Retort room operations.

- (a) The retort room operations shall be under the direct personal supervision of a supervisor or manager certified as having attended an approved course of instruction in retort operation.
- (b) Processes and venting procedures to be used for each product and container size being packed shall be posted in a conspicuous place near the retorts.
- (c) All retort baskets, trucks, cars, or crates containing unretorted material, or some of the containers on the top of such baskets, shall be plainly and conspicuously marked with a heat sensitive indicator which will visually indicate to all cookroom personnel whether or not each such unit has been retorted. If several products are being packed at the same time, units of each product shall be plainly indicated.
- (d) Accurate timing devices which can be easily read to the nearest minute shall be used by retort operators in recording process time information.

Sec. 1.8 Still retorts.

(a) *Definitions.* (1) "Still retorts" mean discontinuous (batch type), nonagitating vertical or horizontal enclosed vessels used for processing low-acid foods.

(2) "Coming-up-time" means the time which elapses between turning on the steam into the closed retort and the time when the retort reaches and maintains the required processing temperature.

(b) *Equipment and installation for pressure processing in steam in still retorts—*

(1) *Indicating mercury-in-glass thermometer.* Still retorts shall be equipped with at least one mercury-in-glass thermometer having a temperature range of not more than 100° F. on a scale at least 7 inches in length. The scale divisions should be no more than 2° F. Thermometers shall be tested for accuracy against a known accurate standard thermometer upon installation and at least once a year thereafter or at any time their accuracy is questioned. Bulbs of indicating thermometers may be installed within the retort shell or in external wells attached to the retort. External wells or pipes shall be connected to the retort through at least a 1/4-inch-diameter opening, and be equipped with one-sixteenth inch or larger bleeder opening so located as to provide a full flow of steam past the length of the thermometer bulb. The bleeder for external wells must emit steam continuously during the entire processing period. Thermometers shall be installed where they are illuminated so that they can be accurately and easily read. A thermometer with a divided mercury column shall be replaced. The mercury thermometer, not the recorder chart, shall be the reference instrument for indicating the processing temperature.

(2) *Recording thermometer.* There shall be a recording thermometer on each still retort. The chart graduations shall not exceed 2° F., within a range of 10° F. of the processing temperature. All charts shall have a working scale of not less than 3 inches. This recorder may be combined with the steam controller and be a recording-controlling instrument. The recording bulb may be installed within the retort shell or in a thermometer well attached to the shell. The well shall be capable of accommodating both the recorder bulb and a mercury-in-glass ther-

mometer. A thermometer well must have a one-sixteenth inch or larger bleeder opening emitting steam continuously during the processing period. The recording thermometer shall in no instance read higher than the accurate mercury-in-glass thermometer.

(3) *Pressure gages.* Each retort should be equipped with a pressure gage graduated in one pound divisions.

(4) *Steam controller.* Each still retort shall be equipped with an automatic steam controller to maintain the retort temperature. This may be a recording-controlling instrument when combined with a recording thermometer.

(5) *Steam inlet.* The steam inlet to each still retort must be large enough to provide sufficient steam for proper venting of the retort. Steam may enter either the top or the bottom of the retort, but must enter the end or side opposite the vent.

(6) *Grate supports (or baffle plates).* Some type of bottom grate support shall be provided in vertical still retorts. Baffle plates shall not be used in the bottom of still retorts.

(7) *Steam spreaders.* Steam spreaders, which are perforated continuations of the steam line inside the retort, should be not larger than the steam inlet line. Spreaders are necessary in all installations except for vertical still retorts vented at the bottom where the steam enters at the top of the retort.

(1) *Horizontal still retorts.* In horizontal still retorts the perforated pipe shall extend along the bottom for the entire length of the retort, and the perforations should be along the top 90° of this pipe. For still retorts over 30 feet long it is desirable to have two inlets connected to the spreader.

(2) *Vertical still retorts.* In vertical still retorts the perforated pipe should preferably be in the form of a cross with the perforations along the top or sides of the pipe. **NOTE:** The number of perforations in spreaders should be such that the total cross sectional area of the perforations is equal to 1 1/2 to two times the cross sectional area of the steam inlet line. The following table may be used as a guide:

NUMBER OF HOLES IN STEAM SPREADERS FOR STEAM INLET PIPE SIZES

Size holes (inches)	1 inch pipe	1 1/4 inch pipe	1 3/4 inch pipe	2 inch pipe	2 3/4 inch pipe
3/8	47-62	51-108	111-148	183-244	260-346
1/2	27-36	45-60	62-84	102-137	147-196
5/8		21-28	28-37	45-60	66-88
3/4		11-15	15-20	26-36	36-48

(8) *Bleeders for retorts or cookers.*

Bleeders are 1/8- to 1/4-inch openings used to remove air entering the retort with the steam and to provide circulation of steam in the retort. Bleeders for thermometer wells may be one-sixteenth inch or larger openings. Bleeders must be wide open and emit steam continuously during the entire process, including the coming-up-time. All bleeder openings shall be arranged in such a way that the operator can observe that steam is escaping during the process. In cases of top steam inlet and bottom venting, an adequately sized bleeder opening shall be installed in the bottom of the retort to insure complete removal of condensate. Its discharge shall be above the retort platform or so located as to be easily observable.

(1) *Horizontal still retorts* shall have at least one bleeder opening within about 1 foot of each end and additional bleeder openings not more than 8 feet apart along the top.

(2) *Vertical still retorts* shall have at least one bleeder opening at the end opposite to that at which steam is admitted.

(9) *Vents.* Vents shall be installed in such a way that all air is removed from the retort before timing of the process is started. Vents must be controlled by gate or plug cock type valves which must be fully open to permit rapid discharge of air from the retort during the venting period. Vents shall not be connected directly to the drain system. If the overflow is used as a vent, there must be an atmospheric break in the line before it connects to the drain. The vent shall be located in the extreme opposite end or side of the retort from that through which the steam is admitted.

(10) *Stacking equipment.* (1) *Stacking equipment (baskets, trays, gondolas, etc.)* for all types of containers in still retorts, when containers are stacked in a vertical position, shall preferably be of strap iron. When perforated sheet metal baskets are used, the perforations in the bottom shall be approximately 1-inch holes on 2-inch centers or their equivalent.

(2) If dividers between layers of containers are used, they shall be of material such as strap iron, sheet metal, or plastic having perforations of approximately the equivalent of 1-inch holes on 2-inch centers.

(3) *Venting of still retorts for processing in steam.* Retort loading systems employing divider plates between each layer of containers require increased venting schedules. Consult a competent laboratory connected with the canning industry for the necessary venting time and temperature. Timing of the process shall not begin until the retort has been properly vented and the processing temperature is reached and maintained. If retorts are equipped with air for pressure cooling, a ball or globe valve shall be used on the air line to avoid air leakage into the retort during processing.

(4) No single venting method is applicable to all still retorts. To assure complete air removal during venting, both time and temperature requirements determined for particular retort installations shall be met.

(5) *Venting and vent manifolds.* Air removal is best accomplished by venting directly to the atmosphere from the gate or plug cock valve controlling the vent. However, it is often desirable to remove the steam vapor from the retort room by connecting the vent pipes to a suitably sized retort manifold and manifold header. A retort manifold connects several vent pipes from a single still retort and is controlled by a gate or plug cock type valve. The retort manifold must be of a size such that the cross sectional area of the pipe is larger than the total cross sectional area of all connecting vents and shall be at least one pipe size larger than the steam inlet. The discharge shall not be directly connected to a drain without an atmospheric break in the line. A manifold header connects vents or manifolds from several still retorts and leads to the atmosphere. The manifold header is not controlled by a valve and must be sized so that the cross sectional area is at least equal to the total cross sectional area of all connecting retort manifold pipes from all still retorts venting simultaneously. If the header is of excessive length, it shall be increased by at least one pipe size.

(6) Some typical installations and operating procedures are given in the following subparagraph (a) through (f). There are other installations and operating procedures which will result in adequate air removal. Variations should be analyzed by qualified individuals connected with the canning industry who shall specify venting schedules to provide adequate air removal. In the following detailed venting procedures the method given requires that the vent valve, steam valve, and steam by-pass, if used, are fully open and that the water and air valves are completely closed.

(a) Venting horizontal still retorts through multiple 1-inch vents discharging directly to atmosphere.

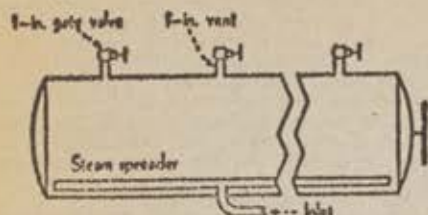

Specifications. One 1-inch vent for every 5 feet of retort length equipped with a gate or quick spring valve discharging to atmosphere. End vents not more than 2½ feet from ends of retort.

Venting method. Vent valves shall be wide open for at least 5 minutes and to at least 225° F. or at least 7 minutes and to at least 220° F.

(b) Venting horizontal still retorts through multiple 1-inch vents discharging through a manifold to atmosphere.

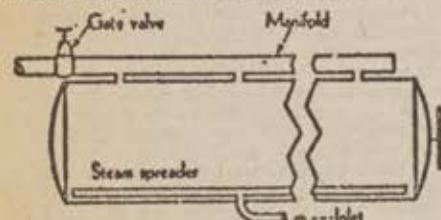

Specifications. One 1-inch vent for every 5 feet of retort length. End vents not over 2½ feet from end of retort.

	Retort length, in feet	
	Under 15	Over 15
Size of manifold.....	2½	3

Venting method. Manifold vent gate valve shall be wide open for at least 6 minutes and to at least 225° F. or at least 8 minutes and to at least 220° F.

(c) Venting horizontal still retorts through water spreaders.

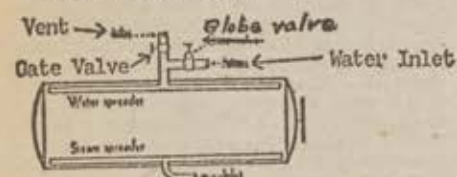

Specifications.

	Retort length, in feet	
	Under 15	Over 15
Size of water and vent valve.....	2	2½
Size of water spreader.....	1½	2

Venting method. Water spreader vent gate valve shall be wide open for at least 5 minutes and to at least 225° F. or at least 7 minutes and to at least 220° F. The number of holes in the water spreader shall be such that their total cross sectional area is equal to the cross sectional area of the water inlet line. The following table may be used as a guide:

NUMBER OF HOLES IN WATER SPREADER FOR WATER INLET PIPE SIZES

Hole size (inches)	1½ in. pipe	1¾ in. pipe	2 in. pipe	2¼ in. pipe	3 in. pipe	3¾ in. pipe
3/8	54	74	122	173	268	358
1/2	40	54	89	127	197	263
5/8	30	42	68	97	150	201
3/4	14	18	30	44	67	90
7/8	10	17	24	38	50	65

(d) Venting horizontal still retorts through a single 2½-inch top vent (for retorts not exceeding 15 feet in length).

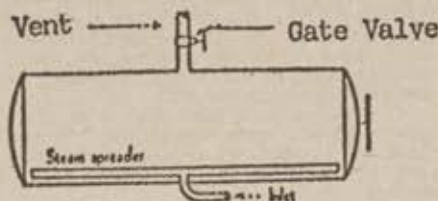

Specifications. A 2½-inch vent equipped with a 2½-inch gate valve located within 2 feet of the center of the retort.

Venting method. Vent gate valve shall be wide open for at least 4 minutes and to at least 220° F.

(e) Venting vertical still retorts through a 1½-inch overflow.

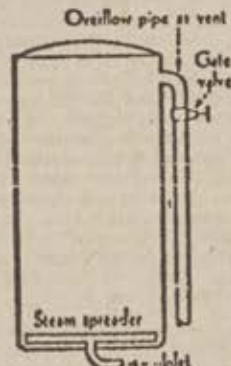

Specifications. A 1½-inch overflow pipe equipped with a 1½-inch gate valve and not more than 6 feet of 1½-inch pipe beyond the valve before break to atmosphere.

Venting method. Vent gate valve shall be wide open for at least 4 minutes and to at least 218° F. or at least 5 minutes and to at least 215° F.

(f) Venting vertical still retorts through a single 1-inch side or top vent.

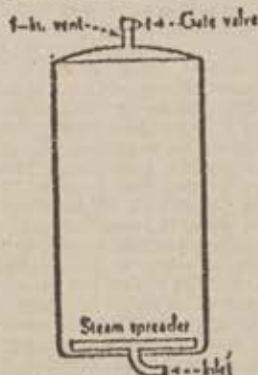

Specifications. A 1-inch vent in lid or top side equipped with a 1-inch gate valve and discharging directly to the atmosphere.

Venting method. Vent gate valve shall be wide open for at least 5 minutes and to at least 230° F. or at least 7 minutes and to at least 220° F.

(c) **Equipment and installation for pressure processing in water in still retorts.** Processing under water with superimposed air pressure is generally practiced for glass containers and requires adequate water circulation to insure uniform temperatures.

(1) **Indicating mercury-in-glass thermometers.** Each still retort shall be equipped with at least one mercury-in-glass thermometer having a temperature range of not more than 100° F. on a scale at least 7 inches in length. The scale divisions shall be no more than 2° F. Thermometers shall be tested for accuracy against a known accurate standard thermometer upon installation and at least once a year thereafter or at any time their accuracy is questioned. The thermometer bulbs shall be located in such a position that they are beneath the surface of the water throughout the process. On horizontal retorts this entry should be made in the side at the center, and the thermometer bulbs shall be inserted directly into the shell. In both vertical and horizontal retorts, the thermometer bulb shall extend directly into the water a minimum of at least 2 inches without a separable well or sleeve. Thermometers shall be installed where they are illuminated so that they can be accurately and easily read. A thermometer with a divided mercury column shall be replaced. The mercury thermometer, not the recorder chart, shall be the reference instrument for indicating the processing temperature.

(2) **Recording thermometer.** There shall be a recording thermometer on each still retort. The chart graduations shall not exceed 2° F. within a range of 10° F. of the processing temperature. All charts shall have a working scale of not less than 3 inches. This recorder may be combined with the steam controller and be a recording-controlling instrument. The recording thermometer bulb should be located adjacent to the bulb of the mercury-in-glass thermometer except in the case of a vertical retort equipped with a combination controller-recorder. In such vertical retorts the temperature recorder-control bulb shall be located at the bottom of the retort below the lowest crate rest in such a position that the steam does not strike it directly. In horizontal retorts the temperature recorder-control bulb shall be located between the water surface and the horizontal plane passing through the center of the retort so that there is no opportunity for direct steam impingement upon the control bulb. The recording thermometer shall in no instance read higher than the accurate mercury-in-glass thermometer.

(3) **Pressure control and indicating equipment.** Automatic controls are required. (i) Water level and pressure controller. The top layer of jars shall be covered with about 6 inches of water and the overflow located accordingly. The opening of the overflow shall be larger than the water supply line. An adjustable pressure relief, or control valve shall be installed in the overflow line of a capacity sufficient to prevent increase in retort pressure when the water valve is wide open.

(ii) **Indicating pressure gage.** The pressure gage shall be graduated in not more than 2 p.s.i. divisions. In a vertical retort the gage shall be located at the thermometer pocket. In a horizontal retort the gage may be either in this position or at the top of the retort.

(iii) **Recording pressure indicator or controller.** The chart shall be easily readable and shall cover the normal operating range.

(4) *Steam supply and introduction.* The general requirement is for a good steam distributor in the bottom of the retort to provide uniform heat distribution throughout the retort. (1) In vertical retorts uniform steam distribution can be achieved by any of several methods. One method is an assembly of six pipes radiating from a center coupling with fish-tail nozzles at the end of each pipe which direct the steam up the walls of the retort outside the crates. Another method is a four-legged cross in which each pipe leg is perforated with holes along one side only. The legs are arranged in opposing pairs to give alternative live and dead quadrants.

(2) In horizontal retorts the steam distributor shall run the full length of the bottom of the retort with perforations distributed uniformly along the upper part of the pipe.

(5) *Grate supports.* Lugs, tracks, or a saddle type support shall be used. A ring support is satisfactory for vertical retorts. In no case shall baffle plates be used in the bottom of the retort.

(6) *Stacking equipment.* (1) Crates, trays, gondolas, etc., for holding containers shall be made of strap iron or adequately perforated sheet metal. When perforated sheet metal is used for bottom of crates, the perforations shall be at least 1-inch holes on 2-inch centers, or their equivalent.

(2) If divider plates are used between each layer of jars, they shall be perforated as above.

(7) *Drain valve.* A nonlogging, watertight valve of at least 125 p.s.i. capacity is required. Screens shall be installed over all drain openings.

(8) *Water level indicator.* (1) A means of determining the water level in the retort shall be provided. This can be accomplished by using a gage water glass or series of petcocks at different levels on the retort.

(2) The water level shall be maintained at approximately 6 inches above the top layer of jars during the entire coming-up-time, process, and cool.

(9) *Air supply and controls.* (1) There shall be a reliable supply of compressed air at the proper pressure and a means of introducing it into the retort at an adequate rate. An automatic pressure control unit is required for both vertical and horizontal still retorts. In both, the air shall be introduced with the steam at the bottom and close to the retort.

(2) Air circulation shall be maintained continuously during the coming-up-time, process, and cool.

(3) A check valve shall be provided in the air supply line to prevent water from entering the system.

(10) *Container cooling water.* (1) A check valve should be included in the cooling waterline to prevent drop of pressure in the retort in case the water pressure should fall below the retort pressure.

(2) In vertical retorts the cooling water should be introduced at the top of the retort below the water level and above the jar level, either through a minimum of four openings equally spaced around the circumference of the retort or through a perforated ring.

(3) In horizontal retorts at the start of the cool, water should be introduced into the suction side of the pump.

(11) *Retort and crate diameters.* There shall be a minimum of 1½-inch clearance between the sidewall of the crate and the retort wall. Centering guides should be installed to assure proper clearance between the sidewall of the crate and the retort wall.

(12) *Retort headspace.* A minimum of 4 inches headspace shall be maintained between the top water level and the top of the retort shell.

(13) *Still retort details for pressure processing in water in still retorts.* (1) Vertical retorts shall follow the arrangement in the following diagram, or be equivalent.

VERTICAL STILL RETORTS FOR WATER PROCESSING

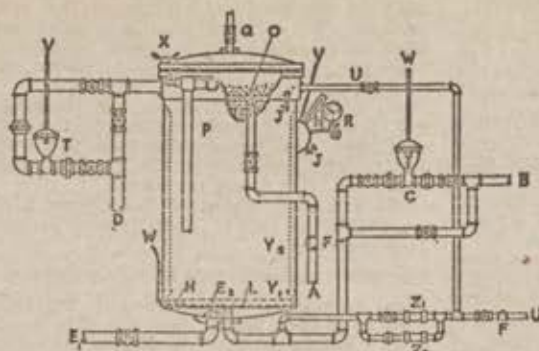

- A Water line
- B Steam line
- C Temperature control
- D Overflow line
- E₁ Drain line
- E₂ Screens
- F Check Valves
- G Line from hot water storage
- H Suction line and manifold
- I Circulating pump
- J Petcocks
- K Recirculating line
- L Steam distributor
- M Temperature controller bulb
- N Thermometer
- O Water spreader
- P Safety valve
- Q Vent valve for steam processing
- R Pressure gauge
- S Inlet air control
- T Pressure control
- U Air line
- V To pressure control instrument
- W To temperature control instrument
- X Wing nuts—S required
- Y₁ Crate support
- Y₂ Crate guides
- Z₁ Constant flow orifice valve used during come-up
- Z₂ Constant flow orifice valve used during cook

(2) Horizontal still retorts shall follow the arrangement in the following diagram, or be equivalent.

HORIZONTAL STILL RETORT FOR WATER PROCESSING

PROCESSING

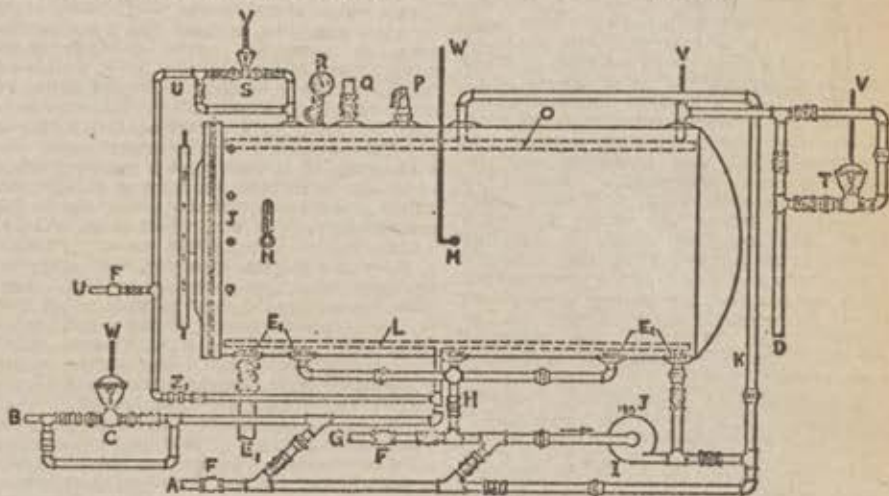

- A Water line
- B Steam line
- C Temperature control
- D Overflow line
- E₁ Drain line
- E₂ Screens
- F Check Valves
- G Line from hot water storage
- H Suction line and manifold
- I Circulating pump
- J Petcocks
- K Recirculating line
- L Steam distributor
- M Temperature controller bulb
- N Thermometer
- O Water spreader

- P Safety valve
- Q Vent valve for steam processing
- R Pressure gauge
- S Inlet air control
- T Pressure control
- U Air line
- V To pressure control instrument
- W To temperature control instrument
- X Wing nuts—S required
- Y₁ Crate support
- Y₂ Crate guides
- Z₁ Constant flow orifice valve used during come-up
- Z₂ Constant flow orifice valve used during cook

(a) *Water circulating system.* A water circulating system is required for heat distribution. This system shall be installed in such a way that water will be drawn from the bottom of the retort through a suction manifold and discharged through a spreader which extends the full length of the top of the retort. The holes in the water spreader shall be uniformly distributed and shall have an aggregate area not greater than the cross-section area of the outlet line from the pump. The suction outlets shall be protected with nonclogging screens to keep debris from entering the circulating system. The pump shall be equipped with a pilot light or other signaling device to warn the

operator when it is not running, and with a bleeder to remove air when starting operations. The size of the suction manifold, circulating system, pump, and water spreader will depend on the size of the retort. The following are suggested as minimum sizes for use:

FOR STILL RETORTS UNDER 15 FEET IN LENGTH

Size of suction manifold,	2 inches.
Number and size of suction outlets from retort to manifold,	Two 1½ inch, equally spaced.
Size of circulating line and pump,	2 inches.
Size of water spreader....	2 inches.

FOR STILL RETORTS OVER 15 FEET IN LENGTH

Size of suction manifold.	2½ inches.
Number and size of suction outlets from retort to manifold.	One 2-inch outlet for each 8 feet of retort length or fraction thereof.
Size of circulating line and pump.	2½ inches.
Size of water spreader.	2½ inches.

Sec. 1.9 Continuous agitating cookers.

(a) *Definition.* In continuous agitating cookers, the containers are conveyed through a steam pressure chamber by means of a rotating reel and a spiral which is affixed to the shell. Entrance and exit of the containers from the pressure shell is accomplished by means of mechanical valves.

(b) *Equipment and installation for pressure processing in steam.*—(1) *Indicating mercury-in-glass thermometer.* Each cooker shell must be equipped with at least one mercury-in-glass thermometer having a temperature range of not more than 100° F. on a scale at least 7 inches in length. The scale divisions should be no more than 2° F. Thermometers shall be tested for accuracy against a known accurate standard thermometer upon installation and at least once a year thereafter or at any time their accuracy is questioned. Bulbs of indicating thermometers may be installed within each cooker shell or in external wells attached to each cooker shell. External wells or pipes shall be connected to each cooker shell through at least a ¼-inch diameter opening, and be equipped with one-sixteenth inch or larger bleeder openings so located as to provide a full flow of steam past the length of the thermometer bulb. The bleeder for external wells must emit steam continuously during the entire processing period. Thermometers shall be installed where they are illuminated so that they can be accurately and easily read. A thermometer with a divided mercury column shall be replaced. The mercury thermometer, not the recorder chart, shall be the reference instrument for indicating the processing temperature.

(2) *Recording thermometer.* A recording thermometer is required on each cooker shell. The chart graduations shall not exceed 2° F., within a range of 10° F. of the processing temperature. All charts should have a working scale of not less than 3 inches. This recorder may be combined with the steam controller and be a recording-controlling instrument. The recording thermometer shall in no instance read higher than the accurate mercury-in-glass thermometer.

(3) *Pressure gages.* Each cooker shell must be equipped with a pressure gage.

(4) *Steam controller.* Each cooker shell must be equipped with an accurate automatic steam controller.

(5) *Bleeders.* Bleeders (one-eighth inch or larger openings) shall be located within approximately 1 foot of each end and additional bleeders not more than 8 feet apart along the top of cooker shells. These bleeders shall be wide open during come-up-time and operating periods.

(6) *Venting and condensate removal.* All air in each cooker shell must be removed before processing is started. The top vent or vents shall be wide open to at least 220° F. and for at least 7 minutes from the time steam is turned on. At the time steam is turned on the drain shall be opened for a time sufficient to remove steam condensate from the cooker and provision shall be made for continuing drainage of condensate during operation. The condensate bleeder in the bottom of the shell serves as an indicator of continuous condensate removal.

(7) *Cooker speed timing.* The continuous pressure cooker supervisor shall adjust and

record the speed on all continuous cookers when they are started and at least every four (4) hours during the operating period. Speed drives should be locked to prevent unauthorized speed changes.

(c) *Critical factors involved in this processing method.* (1) The minimum headspace shall be specified and maintained for each process. The specified minimum headspace shall be measured and recorded periodically after the filler at or above the specified initial temperature and before processing.

(2) Maximum consistency for thickened products shall be specified either on the basis of slowest heat penetration data or by objective measurements on the product taken from the filler before processing.

(3) Minimum speed of the cooker must be specified as part of the individual product heat processes.

Sec. 1.10 Discontinuous agitating cookers.

(a) *Definition.* Discontinuous agitating cookers involve batch operation with agitation provided during the process. Agitation is imparted to the contents of the containers by one of two methods: (1) The container is carried by a reel and rotates as the reel revolves; (2) The containers are in baskets and are rotated around a central axis.

(b) *Equipment and installation for pressure processing in steam.* (1) *Indicating mercury-in-glass thermometer.* Each cooker shall be equipped with at least one mercury-in-glass thermometer having a temperature range of not more than 100° F. on a scale at least 7 inches in length. The scale divisions shall be no more than 2° F. Thermometers shall be tested for accuracy against a known accurate standard thermometer upon installation and at least once a year thereafter or at any time their accuracy is questioned. Bulbs of indicating thermometers may be installed within the retort shell or in external wells attached to the retort through at least a ¼-inch diameter opening, and shall be equipped with one-sixteenth inch or larger openings so located as to provide a full flow of steam past the length of the thermometer bulb. The opening for external wells must emit steam continuously during the entire processing period. Thermometers shall be installed where they are illuminated so that they can be accurately and easily read. A thermometer with a divided mercury column shall be replaced. The mercury thermometer, not the recorder chart, shall be the reference instrument for indicating the processing temperature.

(2) *Recording thermometer.* There shall be a recording thermometer on each cooker. The chart graduations shall not exceed 2° F., within a range of 10° F. of the processing temperature. All charts shall have a working scale of not less than 3 inches. This recorder may be combined with the steam controller and be a recording-controlling instrument. The bulb may be installed within the cooker shell or in a thermometer well attached to the shell. The well shall be capable of accommodating both the recorder bulb and a mercury-in-glass thermometer. The recording thermometer shall in no instance read higher than the accurate mercury-in-glass thermometer.

(3) *Pressure gages.* Each discontinuous pressure cooker for pressure processing in steam should be equipped with a pressure gage.

(4) *Steam controller.* Each discontinuous pressure cooker shall be equipped with an automatic steam controller to accurately maintain the retort temperature.

(5) *Bleeders.* Bleeders are ⅛- to ¼-inch openings used to remove air entering the retort with the steam and to provide circulation of steam in the retort. Bleeders for thermometer wells may be openings one-sixteenth inch or larger. Bleeders must be

wide open and emit steam continuously during the entire process, including the coming-up-time. All bleeders shall be arranged in such a way that the operator can observe that steam is escaping during the process. In cases of top steam inlet and bottom venting, an adequately sized bleeder shall be installed in the bottom of the retort to insure complete removal of condensate. Its discharge shall be so located as to be easily observable.

(6) *Venting and condensate removal.* All air in each cooker shall be removed before processing is started. At the time steam is turned on the drain shall be opened for a time sufficient to remove steam condensate from the cooker and provision shall be made for continuing drainage of condensate during the cooker operation. The condensate bleeder in the bottom of the shell serves as an indicator of continuous condensate removal.

(7) *Cooker speed timing.* The reel speed shall be adjusted as necessary and reel speed as well as process time shall be recorded for each retort load processed. Speed drives should be locked to prevent unauthorized speed changes.

(8) *Critical factors involved in this processing method.* (1) The minimum headspace shall be specified and maintained for each process. The specified minimum headspace shall be measured and recorded periodically after the filler at or above the specified initial temperature and before processing.

(ii) Maximum consistency for thickened products shall be specified either on the basis of slowest heat penetration data or by objective measurements on the product taken from the filler before processing.

(ii) Minimum rotational speed of the cooker shall be specified as part of the individual product heat processes.

(c) *Equipment and installation for pressure processing in water.* (1) *Indicating mercury-in-glass thermometer.* Each cooker shall be equipped with at least one mercury-in-glass thermometer having a temperature range of not more than 100° F. on a scale at least 7 inches in length. The scale divisions shall be no more than 2° F. Thermometers shall be tested for accuracy against a known accurate standard thermometer upon installation and at least once a year thereafter or at any time their accuracy is questioned. Bulbs of indicating thermometers may be installed within the retort shell or in external wells attached to the retort. Thermometers shall be installed where they are illuminated so that they can be accurately and easily read. A thermometer with a divided mercury column shall be replaced. The mercury thermometer, not the recorder chart, shall be the reference instrument for indicating the processing temperature.

(2) *Recording thermometer.* There shall be a recording thermometer on each cooker. The chart graduations shall not exceed 2° F., within a range of 10° F. of the processing temperature. All charts shall have a working scale of not less than 3 inches. This recorder may be combined with the steam controller and be a recording-controlling instrument. The bulb may be installed within the cooker shell or in a thermometer well attached to the shell. The well shall be capable of accommodating both the recorder bulb and a mercury-in-glass thermometer. The recording thermometer shall in no instance read higher than the accurate mercury-in-glass thermometer.

(3) *Pressure gages.* Each discontinuous pressure cooker for pressure processing in water shall be equipped with a pressure gage.

(4) *Steam controller.* Each discontinuous pressure cooker shall be equipped with an

automatic steam controller to accurately maintain the retort temperature.

(5) *Cooker speed timing.* The reel speed shall be adjusted as necessary and reel speed as well as process time shall be recorded for each retort load processed. Speed drives should be locked to prevent unauthorized speed changes.

(6) *Critical factors involved in this processing method.* (1) The minimum headspace shall be specified and maintained for each process. The specified minimum headspace shall be measured and recorded periodically after the filler at or above the specified initial temperature and before processing.

(ii) Maximum consistency for thickened products shall be specified either on the basis of slowest heat penetration data or by objective measurements on the product taken from the filler before processing.

(iii) Minimum rotational speed of the cooker must be specified as part of the individual product heat processes.

Sec. 1.11 Hydrostatic cookers.

(a) *Definition.* A hydrostatic cooker consists of a vertical chamber or chambers which serve as a steam-pressure cooker connected at the base to hydrostatic water legs. The head of water in these legs exerts a counter-balancing pressure on the steam chamber. Adjusting the height of the water column controls the inside steam chamber pressure and, hence, the temperature of sterilization. One or more continuous conveyor chains carry filled containers into the steam chamber through the inlet water leg and out again through an exit water leg. One water leg may serve as both the inlet and exit legs.

(b) *Equipment and installation for pressure processing in steam.* (1) *Indicating mercury-in-glass thermometers.* Each hydrostatic cooker shall be equipped with at least three accurate mercury-in-glass thermometers having a temperature range of not more than 100° F. on a scale of at least 7 inches in length. The scale divisions shall be no more than 2° F. At least one thermometer shall be located in the steam dome near the steam-water interface and at least one thermometer shall be located in each hydrostatic leg in positions and illuminated so that they can be accurately and easily read by the operator. A thermometer with a divided mercury column shall be replaced. The mercury thermometer, not the recorder chart, shall be the reference instrument for indicating the processing temperature.

(2) *Temperature recorders and controllers.* Each hydrostatic cooker shall be equipped with accurate automatic temperature recorders which shall give a record of temperatures on a time reference. The chart graduations shall not exceed 2° F. within a range of 10° F. of the processing (or hydrostatic leg) temperatures. All charts shall have a working scale of not less than 3 inches. The recorders may be combined with steam controllers and be recording-controlling instruments. The bulb may be installed within the steam dome or in a thermometer well attached to the dome. The well shall be capable of accommodating both the recorder bulb and a mercury-in-glass thermometer. The recording thermometers shall in no instance read higher than the accurate mercury-in-glass thermometers.

(3) *Recording of temperatures.* Temperatures indicated by the accurate mercury-in-glass thermometers shall be entered on a suitable form during processing operations. Temperatures shall be recorded by accurate automatic recorders at the following points:

(i) In the side of the steam chamber near the center of the dome height.

(ii) In the steam chamber between the steam-water interface and the lowest container position.

(iii) Near the top and the bottom of each hydrostatic water leg.

(4) *Venting.* Before the start of processing operations the hydrostatic cooker steam chamber or chambers shall be vented to insure complete removal of air.

(5) *Bleeders.* Bleeders are 1/8- to 1/4-inch openings used to remove air entering the steam chamber or chambers with the steam and to provide circulation of steam in the chamber or chambers. Bleeders for thermometer wells may be openings one-sixteenth inch or larger. Bleeder openings (one-fourth inch or larger) shall be located at the end of the steam chamber or chambers opposite from the point of steam entry. Bleeders must be wide open and emit steam continuously during the entire process, including the coming-up-time. All bleeders shall be arranged in such a way that the operator can observe that steam is escaping during the process.

(6) *Cooker speed.* The container conveyor chain speed shall be determined and recorded at the start of processing and at least every 4 hours during the operating period. Chain speed controls should be locked to prevent unauthorized speed changes.

(7) *Container control.* Operation shall be such that there is no opportunity for unprocessed containers to become mixed with processed containers.

Sec. 1.12 Aseptic canning systems.

(a) *Definition.* Aseptic canning is the filling of sterilized product into presterilized containers, followed by aseptic hermetical sealing, with a presterilized lid, if applicable, in an atmosphere free of microorganisms.

(b) *Equipment for product presterilization.* (1) *Timing device.* A suitable device shall be used to give the constant desired rate of product flow. The timing device should be locked to prevent unauthorized changes in the rate of product flow.

(2) *Indicating mercury-in-glass thermometer.* Each product presterilizer shall be equipped with at least one mercury-in-glass thermometer having a temperature range of not more than 100° F. on a scale of at least 7 inches in length. The scale divisions should be no more than 2° F. within 10° F. of the product sterilization operating range. The thermometer shall be installed in the presterilized product holding tube outlet between the holding tube and the cooler inlet. Thermometers shall be tested for accuracy against a known accurate standard thermometer upon installation and at least once a year thereafter or at any time their accuracy is questioned. Mercury-in-glass thermometers shall be installed where they are illuminated so that they can be accurately and easily read. A thermometer with a divided mercury column shall be replaced. The mercury thermometer, not the recorder chart, shall be the reference instrument for indicating the presterilization temperature.

(3) *Temperature recording thermometers.* There shall be an automatic recording thermometer on each product presterilizer located in the presterilized product holding tube outlet between the holding tube and the cooler inlet. The chart graduations shall not exceed 2° F., within a range of 10° F. of the desired product sterilization temperature. All charts shall have a working scale of not less than 3 inches. The recording thermometer shall in no instance read higher than the accurate mercury-in-glass thermometer.

(4) *Temperature recorder controller.* An accurate temperature recorder controller shall be located in the product sterilizer heater just prior to the inlet of the product holding tube. It shall be capable of maintaining the desired product temperature. The chart graduations shall not exceed 2° F.,

within a range of 10° F. of the desired heater outlet temperature.

(5) *Product holding tube.* The holding tube shall be designed to give continuous holding of every particle of food for at least the minimum required holding time. The holding tube shall be designed so that no portion between the product inlet and the product outlet can be heated.

(c) *Operation.* (1) Before starting aseptic processing operations the entire system shall be sterilized.

(2) *Operating records.* Temperatures at the following points are to be observed and recorded at the start of aseptic canning operations and at least every hour during such operations:

(i) Mercury thermometer in holding tube outlet between holding tube and cooler inlet;

(ii) Product temperature recorder controller at heater outlet;

(iii) Product temperature recorder at end of holding tube;

(iv) Container sterilization chambers;

(v) Cover sterilizer chambers (if applicable);

(vi) Filler housing; and

(vii) Closure housing.

(3) In the event production is stopped due to a temperature drop, container jam, or for any other reason, the time and reason shall be recorded in the operation record. If the reason for the shutdown necessitates the opening of any part of the aseptic equipment, the parts thus exposed shall be re-sterilized before resuming operations.

Sec. 1.13 Flame sterilizers.

(a) *Definition.* Flame sterilizers are atmospheric pressure units in which hermetically sealed containers are agitated, by either continuous, discontinuous, or reciprocating movement, over gas flames to achieve sterilization temperatures. A holding period in a heated chamber may follow the initial heating period, prior to cooling.

(b) *Operating conditions.* (1) The container conveyor speed shall be timed and recorded at the start of operations and at least every 4 hours during operation.

(2) The surface temperature of at least one container from each conveyor channel shall be measured by a suitable device and recorded at the end of the holding period at a minimum of every sixty (60) minutes of operation.

(3) The records shall be entered on a suitable form to indicate time of process, final container temperature before cooling, product, code, nature of container, and container size.

Sec. 1.14 New systems for processing low-acid foods.

Each new system intended for achieving commercial sterility for low-acid foods shall meet the following requirements.

(a) The critical processing conditions shall be determined by acceptable scientific methods. These include monitoring and recording of process time, temperature, and speed (if the system involves continuous or discontinuous agitation of the containers).

(b) Temperature and time, accuracy of instrumentation and any other pertinent factors shall be recorded as substantiation of the proposed system.

Sec. 1.15 Cooling requirements.

(a) All container cooling water, except cooling water used in retorts or cookers, shall be chlorinated as necessary by the processor to a point so that there is at least 0.5 p.p.m. free chlorine residual at the water discharge point of the container cooler. If cooling is accomplished in the retorts or cookers, potable water may be used without additional chlorination.

(b) In pressure cooling, adequate pressure shall be maintained for a time sufficient to prevent permanent distortion of the container.

(c) Duration of cooling should be sufficient to bring the average temperature of the container contents to about $95^{\circ} \pm 5^{\circ}$ F. If external rusting is a problem, the containers should be dried, or water cooling should be carried to an average product temperature of approximately 120° F. and subsequent cooling of such containers should be in air to an average product temperature of approximately $95^{\circ} \pm 5^{\circ}$ F. before they are cased for storage.

Pursuant to provisions of the Federal Food, Drug, and Cosmetic Act (sec. 701, 52 Stat. 1055; 21 U.S.C. 371) and under authority delegated to the Commissioner (21 CFR 2.120), interested persons are invited to submit their comments in writing (preferably in quintuplicate) regarding this proposal within 60 days after its date of FEDERAL REGISTER publication. Such views and comments should be addressed to the Hearing Clerk, Department of Health, Education, and Welfare, Room 6-88, 5600 Fishers Lane, Rockville, MD 20852, and may be accompanied by a memorandum or brief in support thereof. Received comments may be seen in the above office during working hours, Monday through Friday.

Dated: October 28, 1971.

CHARLES C. EDWARDS,
Commissioner of Food and Drugs.

[FR Doc.71-16318 Filed 11-11-71;8:45 am]

Public Health Service

[42 CFR Part 73]

BIOLOGICAL PRODUCTS

Periodic Check on Sterile Technique for Human Whole Blood

During the inspection of establishments licensed for whole blood (human), the records of the tests performed on units of whole blood (human) as a periodic check on sterile technique, presently required by § 73.3004(b), have been carefully examined. These inspection reports indicate that the percentage of positive results is very small, and when the test is repeated as required, the results almost invariably indicate that the contamination was caused by the testing technique itself, rather than inherent contamination of the unit tested. Further, the widespread use of blood collecting containers with integral donor sets has greatly diminished the possible ways of contaminating the unit.

In view of the above, notice is hereby given that the Director, National Institutes of Health, proposes to amend Part 73 of the Public Health Service regulations by requiring that a periodic check on sterile technique need only be performed when blood components are prepared in an open or vented system, as when glass blood collecting containers are used.

Inquiries may be addressed and data, views, and arguments may be presented by interested parties, in writing, in triplicate, to the Director, Division of Biology Standards, National Institutes of

Health, 9000 Rockville Pike, Bethesda, MD 20014. All comments received in response to this notice are available for public inspection in the Office of the Assistant to the Director, Division of Biology Standards, Room 122, Building 29, National Institutes of Health, weekdays during regular business hours. All relevant material received not later than 30 days after publication of this notice of proposed rule making in the FEDERAL REGISTER will be considered.

Notice is also given that it is proposed to make any amendments that are adopted effective 30 days after date of publication in the FEDERAL REGISTER.

It is therefore proposed to amend Part 73 as set forth below:

Dated: November 8, 1971.

ROBERT Q. MARSTON,
Director,
National Institutes of Health.

Amend § 73.3004(b) by revising the first sentence to read as follows:

§ 73.3004 General requirements.

(b) *Periodic check on sterile technique.* Where blood is collected in a vented or open system, such as glass containers, at least one container of such blood that upon visual examination appears normal shall be tested each month between the 18th and 24th day after collection, as a continuing check on technique of blood collection, as follows:

(Sec. 215, 58 Stat. 690, as amended; 42 U.S.C. 216, sec. 351, 58 Stat. 702, as amended; 42 U.S.C. 262)

[FR Doc.71-16569 Filed 11-11-71;8:49 am]

Social Security Administration

[20 CFR Part 404]

[Reg. No. 4]

FEDERAL OLD-AGE, SURVIVORS, AND DISABILITY INSURANCE

Evidence of Adoption

Notice is hereby given pursuant to the Administrative Procedure Act (5 U.S.C. 552 et seq.) that the regulation set forth in tentative form below is proposed by the Commissioner of Social Security, with the approval of the Secretary of Health, Education, and Welfare. The proposed regulation would make a birth certificate issued as the result of an adoption adequate evidence of the adoption.

Prior to final adoption of the proposed regulation, consideration will be given to any data, views, or arguments pertaining thereto which are submitted in writing in triplicate to the Commissioner of Social Security, Department of Health, Education, and Welfare Building, Fourth and Independence Avenue SW., Washington, DC 20201, within a period of 30 days from the date of publication of this notice in the FEDERAL REGISTER.

Copies of all comments received in response to this notice will be available for public inspection during regular busi-

ness hours at the Washington Inquiries Section, Office of Public Affairs, Social Security Administration, Department of Health, Education, and Welfare, North Building, Room 3193, 330 Independence Avenue SW., Washington, DC 20201.

The proposed regulation is to be issued under the authority contained in sections 205 and 1102, 53 Stat. 1368 as amended, 49 Stat. 647, as amended; section 5 of Reorganization Plan No. 1 of 1953, 67 Stat. 18, 631; 42 U.S.C. 405 and 1302.

Dated: October 8, 1971.

ROBERT M. BALL,
Commissioner of Social Security.

Approved: November 7, 1971.

ELLIOT L. RICHARDSON,
Secretary of Health, Education,
and Welfare.

Regulations No. 4 of the Social Security Administration (20 CFR Part 404) are further amended as follows:

Paragraph (a) of § 404.714 is revised to read as follows:

§ 404.714 Evidence as to adoption.

(a) *General.* If the relationship is by adoption, the applicant shall submit evidence to establish the adoption. A birth certificate issued as the result of the adoption proceedings will be considered adequate evidence of the adoption. Other evidence of probative value will also be acceptable to establish the adoption. Where the date of adoption is material, evidence of probative value establishing such date shall be submitted.

[FR Doc.71-16559 Filed 11-11-71;8:49 am]

DEPARTMENT OF TRANSPORTATION

Federal Aviation Administration

[14 CFR Part 71]

[Airspace Docket No. 71-RM-21]

CONTROL ZONE AND TRANSITION AREA

Proposed Alteration

The Federal Aviation Administration is considering an amendment to Part 71 of the Federal Aviation regulations that would alter the description of the Butte, Mont. control zone and transition area.

Interested persons may participate in the proposed rule-making by submitting such written data, views, or arguments as they may desire. Communications should be submitted in triplicate to the Chief, Air Traffic Division, Federal Aviation Administration, Park Hill Station, Post Office Box 7213, Denver, CO 80207. All communications received within 30 days after publication of this notice in the FEDERAL REGISTER will be considered before action is taken on the proposed amendment. No public hearing is contemplated at this time, but arrangements for informal conferences with Federal Aviation Administration officials may be made by contacting the Regional Air

Traffic Division Chief. Any data, views, or arguments presented during such conferences must also be submitted in writing in accordance with this notice in order to become part of the record for consideration. The proposal contained in this notice may be changed in the light of comments received.

A public docket will be available for examination by interested persons in the Office of the Regional Counsel, Federal Aviation Administration, 10255 East 25th Avenue, Aurora, CO 80010.

The airspace requirements for Butte, Mont. have been reviewed in accordance with the criteria contained in the U.S. Standard for Terminal Instrument Procedures (TERPS). As a result of the review, it has been determined that the control zone and transition area must be altered to provide controlled airspace protection for the instrument procedures.

In consideration of the foregoing, the FAA proposes the following airspace action.

In § 71.171 (36 F.R. 2055) the following control zone is amended to read as follows:

BUTTE, MONT.

Within a 5-mile radius of the Silver Bow County Airport, Butte, Mont. (latitude 45° 57'15" N., longitude 112°29'50" W.) and within 2 miles each side of the Butte VORTAC 115° radial extending from the 5-mile-radius zone to the VORTAC.

In § 71.181 (36 F.R. 2140) the following transition area is amended to read as follows:

BUTTE, MONT.

That airspace extending upward from 700 feet above the surface within a 6-mile radius of the Butte VORTAC and within 6 miles southwest and 10 miles northeast of the VORTAC 325° radial, extending from the VORTAC to 11 miles northwest of the VORTAC; and that airspace extending upward from 1,200 feet above the surface within 4½ miles southwest and 9½ miles northeast of the VORTAC 325° radial extending from the VORTAC to 18.5 miles northwest of the VORTAC, and within 4½ miles west and 9½ miles east of the VORTAC 002° radial extending from the VORTAC to 18.5 miles north of the VORTAC.

This amendment is proposed under the authority of section 307(a) of the Federal Aviation Act of 1958, as amended (49 U.S.C. 1348(a)), and of section 6(c) of the Department of Transportation Act (49 U.S.C. 1655(c)).

Issued in Aurora, Colo., on November 4, 1971.

M. M. MARTIN,

Director, Rocky Mountain Region.

[FR Doc.71-16528 Filed 11-11-71;8:46 am]

[14 CFR Part 71]

[Airspace Docket No. 71-WE-54]

CONTROL ZONE AND TRANSITION AREA

Proposed Alteration

The Federal Aviation Administration is considering an amendment to Part 71 of the Federal Aviation Regulations that would alter the descriptions of the Flag-

staff, Ariz. (Pulliam Airport), control zone and transition area.

Interested persons may participate in the proposed rule making by submitting such written data, views, or arguments as they may desire. Communications should be submitted in triplicate to the Chief, Airspace and Procedures Branch, Federal Aviation Administration, 5651 West Manchester Boulevard, Post Office Box 92007, Worldway Postal Center, Los Angeles, CA 90009. All communications received within 30 days after publication of this notice in the FEDERAL REGISTER will be considered before action is taken on the proposed amendments. No public hearing is contemplated at this time, but arrangements for informal conferences with Federal Aviation Administration officials may be made by contacting the Regional Air Traffic Division Chief. Any data, views, or arguments presented during such conferences must also be submitted in writing in accordance with this notice in order to become part of the record for consideration. The proposals contained in this notice may be changed in the light of comments received.

A public docket will be available for examination by interested persons in the office of the Regional Counsel, Federal Aviation Administration, 5651 West Manchester Boulevard, Los Angeles, CA 90045.

The current VOR-radial 070 instrument approach procedure to Pulliam Airport, Flagstaff, Ariz., will be canceled. A new VOR-A instrument approach has been developed utilizing the 127° T (113° M) radial of the Flagstaff VOR for final approach course, procedure turn and holding procedure. These changes require amending the currently designated airspace for Pulliam Airport.

In consideration of the foregoing, the FAA proposes the following airspace actions.

In § 71.171 (36 F.R. 2055) the description of the Flagstaff, Ariz. (Pulliam Airport), control zone is amended to read as follows:

FLAGSTAFF, ARIZ. (PULLIAM AIRPORT)

Within a 7-mile radius of Pulliam Airport (latitude 35°08'16" N., longitude 111°40'17" W.) and within 2 miles each side of the Flagstaff VOR 127° radial, extending from the 7-mile-radius zone to 10 miles southeast of the VOR.

In § 71.181 (36 F.R. 2140) the description of the Flagstaff, Ariz. (Pulliam Airport), transition area is amended to read as follows:

FLAGSTAFF, ARIZ. (PULLIAM AIRPORT)

That airspace extending upward from 700 feet above the surface within an 11.5-mile radius of Pulliam Airport (latitude 35°08'16" N., 111°40'17" W.), and that airspace extending upward from 1,200 feet above the surface within 9.5 miles each side of the Flagstaff VOR 127° and 307° radials, extending from 8 miles northwest to 19 miles southeast of the VOR, excluding that portion within R-2302.

These amendments are proposed under the authority of section 307(a) of the Federal Aviation Act of 1958, as amended (49 U.S.C. 1348(a)), and of section 6(c)

of the Department of Transportation Act (49 U.S.C. 1655(c)).

Issued in Los Angeles, Calif., on November 4, 1971.

ROBERT O. BLANCHARD,
Acting Director, Western Region.

[FR Doc.71-16529 Filed 11-11-71;8:46 am]

[14 CFR Part 71]

[Airspace Docket No. 71-WE-55]

CONTROL ZONE AND TRANSITION AREA

Proposed Alteration

The Federal Aviation Administration is considering amendments to Part 71 of the Federal Aviation Regulations that would alter the descriptions of the Needles, Calif., control zone and transition area.

Interested persons may participate in the proposed rule making by submitting such written data, views, or arguments as they may desire. Communications should be submitted in triplicate to the Chief, Airspace and Procedures Branch, Federal Aviation Administration, 5651 West Manchester Boulevard, Post Office Box 92007, Worldway Postal Center, Los Angeles, CA 90009. All communications received within 30 days after publication of this notice in the FEDERAL REGISTER will be considered before action is taken on the proposed amendment. No public hearing is contemplated at this time, but arrangements for informal conferences with Federal Aviation Administration officials may be made by contacting the Regional Air Traffic Division Chief. Any data, views, or arguments presented during such conferences must also be submitted in writing in accordance with this notice in order to become part of the record for consideration. The proposals contained in this notice may be changed in the light of comments received.

A public docket will be available for examination by interested persons in the office of the Regional Counsel, Federal Aviation Administration, 5651 West Manchester Boulevard, Los Angeles, CA 90045.

A new instrument approach procedure (VOR-A), departure and holding procedures have been developed at Needles Airport, Calif. These new procedures will require a small amount of additional 1,200 foot transition area and allow deletion of the control zone extension.

In consideration of the foregoing, the FAA proposes the following airspace actions.

In § 72.171 (36 F.R. 2055) the description of the Needles, Calif., control zone is amended to read as follows:

NEEDLES, CALIF.

Within a 5-mile radius of Needles Airport (latitude 34°46'05" N., longitude 114°37'30" W.).

In § 71.181 (36 F.R. 2140) the description of the Needles, Calif. transition area is amended to read as follows:

NEEDLES, CALIF.

That airspace extending upward from 1,200 feet above the surface within 9 miles south

and 13 miles north of the Needles VORTAC 092° and 272° radials, extending from 11 miles west to 24 miles east of the VORTAC.

These amendments are proposed under the authority of section 307(a) of the Federal Aviation Act of 1958, as amended (49 U.S.C. 1348(a)), and of section 6(c) of the Department of Transportation Act (49 U.S.C. 1655(c)).

Issued in Los Angeles, Calif. on November 5, 1971.

ROBERT O. BLANCHARD,
Acting Director, Western Region.

[FR Doc.71-16530 Filed 11-11-71;8:46 am]

Office of Pipeline Safety

[49 CFR Part 192]

[Notice No. 71-5; Docket No. OPS-5]

CORROSION PITTING

Withdrawal of Notice of Proposed Rule Making

The purpose of this notice is to withdraw NPRM 71-3 (36 F.R. 12309) which would amend §§ 192.485 and 192.487 of the natural gas pipeline safety regulations.

On July 20, 1971, a public hearing was held to give interested persons an opportunity to present new material on corrosion pitting or to demonstrate that the proposed criteria set out in NPRM 71-3 were inappropriate. After analyzing the material and comments presented it became apparent that the amendments as proposed were inappropriate for several reasons. As a result, the Department has reevaluated the proposal and decided by this action to withdraw the proposed amendments in NPRM 71-3.

The present §§ 192.485(b) and 192.487(b) include general criteria on corrosion pitting, and leave to the operator's discretion to determine the severity of pitting that requires remedial action. They were issued as interim regulations only. The Department plans to initiate more definitive standards, but until more appropriate criteria can be developed the present §§ 192.485(b) and 192.487(b) will remain in effect.

The withdrawal herein of NPRM 71-3 is made under the authority of the Natural Gas Pipeline Safety Act of 1968 (49 U.S.C. 1671 et seq.); Part 1, Regulation of the Office of the Secretary of Transportation, 49 CFR Part 1; and the delegation of authority to the Director, Office of Pipeline Safety (33 F.R. 16468).

Issued in Washington, D.C., on November 8, 1971.

JOSEPH C. CALDWELL,
Acting Director,
Office of Pipeline Safety.

[FR Doc.71-16558 Filed 11-11-71;8:49 am]

INTERSTATE COMMERCE COMMISSION

[49 CFR Part 1115]

[Ex Parte No. 279]

ISSUANCE OF SECURITIES, ASSUMPTION OF OBLIGATIONS, AND FILING OF CERTIFICATES AND REPORTS

Proposed Form of Offering Circular Required for Public Sales of Securities

At a general session of the Interstate Commerce Commission, held at its office in Washington, D.C., on the 29th day of October 1971.

Securities issued pursuant to Commission authority under section 20a or 214 of the Act are subject to "such terms and conditions as the Commission may deem necessary and appropriate in the premises * * *" (section 20a(3)). In those instances where carriers desire to issue securities to the public at large, it has been the standard practice of the Commission to require the applicant to sell such securities by prospectus or offering circular only, in the general form and manner prescribed by the Securities and Exchange Commission.

Currently, the volume of these public offerings has reached a sufficient number so that, in the interests of convenience and standardization, the Commission proposes to amend its form BF-6, Item 7, to set forth its required form and procedure in these matters. Our proposed new Item 7 is contained in Appendix I attached to this notice and order.

The information required in the ICC "prospectus," termed "Offering Circular of Security by Transportation Company," is essentially styled after the Securities and Exchange Commission S-1 form. Bold type statements with regard to ICC jurisdiction will notify the public that the Securities and Exchange Commission does not have jurisdiction over the issue. Persons concerned with securities matters should carefully review the tendered regulation to note other departures from standard SEC practices.

Anyone wishing to present their views and evidence, either in support of, or in opposition to, the action proposed in this order may do so by the submission of written data, views, or arguments.

It is ordered, That a proceeding be, and it is hereby, instituted under the authority of the Interstate Commerce Act and the Administrative Procedure Act (60 Stat. 237, as amended; 5 U.S.C.A. secs. 553 and 559) for the purpose above described; that any views to be expressed by persons interested in this matter shall be filed with this Commission within 30 days of the publication of this order in the FEDERAL REGISTER; and that such views should specifically show any objection to these proposed regulations, with such responses to be presented on any item-by-item basis.

It is further ordered, That an original and 15 copies of such data, views, or arguments shall be filed with the Commission on or before December 11, 1971, and a copy thereof shall be served simultaneously upon each of the Commission's regional headquarters identified in Appendix II of this notice and order. All statements will be a part of the record of this proceeding and will be available for public inspection at the offices of the Interstate Commerce Commission, 12th and Constitution Avenue NW., Washington, DC, during regular business hours.

It is further ordered, That notice to the general public of the matter here under consideration will be given by depositing a copy of this notice in the Office of the Secretary of this Commission, and in each of this Commission's regional headquarters identified in Appendix II to this notice for public inspection and by filing a copy with the Director, Office of the Federal Register.

And it is further ordered, That these proposed regulations shall become effective 60 days from their publication in the FEDERAL REGISTER, unless otherwise ordered by this Commission.

By the Commission.

[SEAL]

ROBERT L. OSWALD,
Secretary.

APPENDIX I

PROPOSED ITEM 7 OF FORM BF-6

ITEM 7. Contracts, underwritings, and other arrangements; public offerings.

(a) How and to whom, and by or through whom, it is proposed to issue the securities, with copies of all contracts, underwritings, and other arrangements made or proposed to be made in connection with the issue. The applicant must require the underwriter to undertake to provide copies of any required offering circular to prospective investors and persons directly solicited to invest their funds in the security.

(b) If applicant is effecting, causing to be effected, or has arranged for, the public offering of a transportation security, and said offer will be tendered to 25 or more prospective investors at a total price of not less than \$100,000, applicant must submit an offering circular for consideration by this Commission. Separate issuances made within one year will be considered as one issuance for the purposes of this paragraph.

(1) General instructions:

(i) The financial representations contained in the offering circular should conform to generally-accepted principles of accounting. However, where there is a dissimilarity between a figure computed pursuant to generally-accepted accounting principles, and the figure produced under the Commission's Uniform System of Accounts, 49 CFR 1200-1219, the differences should be explained by footnoting the item under consideration. Any such footnote should be in language which adequately explains the reason for the difference to the ordinary investor.

(ii) A copy of any advertisement connected with the issue, such as "tombstone" or "red herring" advertisement, shall be attached to the application.

(iii) In the event the price of the security will not be determined by an existing market, or a formula relevant to market prices, as in the case of new issuances, the offering

circular shall be made available to prospective investors, and likewise shall be furnished to those directly solicited to invest their funds in the security, when the order of the Commission authorizing the issuance of the securities becomes effective; but no sales or contracts to sell the securities, except to underwriters, may be made until 14 days, or as otherwise ordered, after the distribution of the authorized offering circular has taken place, this time period beginning from midnight of the day the distribution was initiated, including weekends and holidays. In all other cases, the same requirements as those in the above portion of this paragraph shall be applicable, except the waiting period will run for a period of 3 days, or as otherwise ordered by the Commission. Where an applicant elects to take the shorter 3-day period, the reasons for the inapplicability of the 14-day period shall be specified.

(iv) The information presented in the offering circular should be presented in plain and concise language. Excessively verbose or complex descriptions may confuse the investor and should be avoided. Inapplicable items may be omitted and cross-references, unless otherwise indicated, may be employed.

(v) The offering circular shall contain an opinion of a Certified Public Accountant as to the financial representations contained therein.

(vi) For purposes of this form, and as a term of art limited in its application to these particular regulations, a "speculation" or "speculative security" is one where applicant has not had any substantial gross revenues or receipts from transportation or from the sale of services, or any substantial net income from any source, for any fiscal year ended the past 5 years, has not succeeded and does not intend to succeed such a concern, and does not have and does not intend to have any subsidiaries other than inactive subsidiaries with no more than nominal assets. If this offering is a speculation, an introductory statement shall be made in the offering circular summarizing the factors which make the offering a speculation and setting forth such matters as a comparison, in percentages, of the securities being offered to the public for cash and those issued or to be issued to promoters, directors, officers, controlling persons and underwriters for cash, property, and services. Such applicants will follow the special instructions in the offering circular.

(vii) Attach to the offering circular, for the use of the Commission, a check list of the items required in the offering circular form. Identify the page(s) at which the item appears in the draft offering circular.

(2) Form and content of offering circular:

I. *Caption and distribution spread.* The outside front cover of the offering circular shall contain the information below in substantially the form indicated.

OFFERING CIRCULAR OF SECURITY BY
TRANSPORTATION COMPANY

Distribution of this offering circular was initiated _____ (Date). Investors may not buy, nor contract to buy this issue until _____ (See General Instructions (iii)).

(number of shares)

(name of issuer as it appears on securities)
(type of security; description)

The issuance of these securities has been authorized by the Interstate Commerce Commission which does not pass upon the investment merit of these securities nor upon the accuracy of the information therein.

This offering circular is an integral part of issuer's application under section 20(a) or 214 of the Interstate Commerce Act. This

issue is not subject to the jurisdiction of Securities and Exchange Commission.

	Price to public	Underwriting discounts and commissions	Proceeds to registrant or other persons
Per unit.....			
Total.....			

Instructions. 1. Only commissions paid by the applicant or selling security holders in cash are to be included in the table. Commissions paid by other persons, and other considerations to the underwriters, shall be set forth following the table with a reference thereto in the second column of the table. Any finder's fee or similar payments shall be appropriately disclosed.

2. If the securities are to be offered at the market, or if the offering price is to be determined by a formula related to market prices, indicate the market involved and the market price as of the latest practicable date. Otherwise, the authorized offering circular must contain the sales price and commissions.

II. *Plan of distribution.* (a) If the securities are to be offered through underwriters, give the names of the principal underwriters, and state the respective amounts underwritten. Identify each such underwriter having a material relationship to the issuer and state the nature of the relationship. State briefly the nature of the underwriters' obligation to take the securities.

Instruction. The description of the nature of the underwriters' obligation shall disclose whether the underwriters are, or will be, committed to take and to pay for all of the securities if any are taken, or whether it is merely an agency or "best efforts" arrangement under which the underwriters are required to take and pay for only such securities as they may sell to the public. Conditions precedent to the underwriters' taking the securities, including "market outs", need not be described except in the case of an agency or "best efforts" arrangement. All purchase agreements, underwriting agreements and agreements among underwriters must be submitted as part of the application.

(b) State briefly the discounts and commissions to be allowed or paid to dealers, including all cash, securities, contracts or other consideration to be received by any dealer in connection with the sale of the securities.

Instruction. If any dealers are to act in the capacity of sub-underwriters and are to be allowed or paid any additional discounts or commissions for acting in such capacity, a general statement to that effect will suffice without giving the additional amounts to be so paid.

(c) Outline briefly the plan of distribution of any securities to be applied which are to be offered otherwise than through underwriters.

III. *Use of proceeds accruing to applicant.* State the principal purposes for which the net proceeds from the securities to be offered are intended to be used, and the approximate amount intended to be used for each such purpose.

Instructions. 1. Details of proposed expenditures need not be emphasized; for example, it is necessary to furnish only a brief outline of any program of construction or addition of equipment. If any material amount of other funds is to be used in conjunction with the proceeds, state the amount and sources of such other funds. If any material amount of the proceeds is to be used to acquire assets, otherwise than in the ordinary course of business, briefly describe the assets and give the names of the persons from whom they are to be acquired.

State the cost of the assets to the registrant and the principle followed in determining such cost.

2. In the case of speculative securities, include a statement as to the use of the actual proceeds if they are not sufficient to accomplish all of the purposes set forth, whether or not the funds will be returned to subscribers in such case and, if not, the order of priority in which the proceeds will be used for the respective purposes.

IV. *Sales to current holders.* If any of the securities are to be offered for the account of security holders, name each such security holder and state the amount of securities of the class owned by him, the amount to be offered for his account and the percentage of the class (if 1 percent or more) to be owned by him after completion of the offering.

V. *Capital structure.* Furnish the information called for by the following table, in substantially the tabular form indicated, as to each class of securities of the applicant and each class of securities, other than those owned by the applicant or its totally-held subsidiaries, of all subsidiaries whose financial statements are filed with the offering circular on either a consolidated or individual basis:

Title of class	Amount authorized or to be authorized	Amount outstanding as of a specified date within 90 days	Amount to be outstanding if all securities belong registered are sold

Instructions. 1. Securities held by or for the account of the issuer thereof are not to be included in the amount outstanding, but the amount so held shall be stated in a note to the table.

2. Indebtedness evidenced by drafts, bills of exchange, bankers' acceptances, or promissory notes may be set forth in a single aggregate amount under an appropriate caption such as "Sundry Indebtedness."

3. Applicant may, at its option, include in the table the capital share liability in dollars, as well as the amount, of each class of shares shown in the table, together with surplus attributed to each class of stock. Surplus shall be shown in the same manner as in the balance sheet of applicant, or in the consolidated balance sheet of the applicant and subsidiaries, if such a consolidated balance sheet is included in the offering circular.

VI. *Sales other than for cash.* If any of the securities are to be offered otherwise than for cash, state briefly the general purposes of the distribution, the basis upon which the securities are to be offered, the amount of compensation and other expenses of distribution, and by whom they are to be borne.

Instruction. If the distribution is to be made pursuant to a plan of acquisition, reorganization, readjustment or succession, describe briefly the general effect of the plan and state when it became or is to become operative. If any of the securities are to be offered in exchange for securities of any other issuer, the offering circular shall contain a description of the exchange. State the relationship of the recipient of the securities to the company, including any promoter.

VII. *Information regarding issuer.* State the year in which applicant was organized, its form of organization, and the name of the State or other jurisdiction under the laws of which it was organized, and each of the States under above laws it is authorized to operate.

List all the parents of applicant showing the basis of control and, as to each parent, the percentage of voting securities owned or other basis of control.

Briefly describe the parent's business activities, other than those of applicant. If applicant's parent is, in turn, controlled by another parent company, etc., describe that relationship.

Instructions. What is required is information that will describe any complex control situation to the prospective investor. And will inform him as to any proposed plans, such as acquisitions, sales, intercorporate transfers, dividend payments, spinoffs, etc., by the management of the parent corporation that will have a direct bearing on the financial wellbeing of the carrier subsidiary in which the investor is being asked to invest.

Briefly describe the business actually done and intended to be done (not merely relating the powers authorized in the charter). The relative importance and size of various service and manufacturing endeavors should be furnished specifying those areas subject to regulation under the Interstate Commerce Act.

If the applicant and its subsidiaries are engaged in more than one line of business, state, for each of the applicant's last 5 fiscal years, the approximate amount or percentage of (i) total sales and revenues, and (ii) income (or loss) before income taxes and extraordinary losses, attributable to each line of business which during either of the last 2 fiscal years accounted for—

(A) 10 percent or more of total sales and revenues,

(B) 10 percent or more of income before income taxes and extraordinary items computed without deduction of loss resulting from operations of any line of business, or

(C) a loss which equalled or exceeded 10 percent of the amount of income specified in (B) above.

If it is impracticable to state the contribution to income (or loss) before income taxes and extraordinary items for any line of business, state the contribution thereof to the result of operations most closely approaching such income, together with a brief explanation of the reasons why it is not practicable to state the contribution to such income or loss.

Instructions. 1. If the number of lines of business for which information is required exceeds 10, the applicant may, at its option, furnish the required information only for the 10 lines of business deemed most important to an understanding of overall operations. In such event, a statement to that effect shall be set forth.

2. In grouping products or services as lines of business, appropriate consideration shall be given to all relevant factors, including rates of profitability of operations, degrees of risk and opportunity for growth. The basis for grouping such products or services and any material changes between periods in such groupings shall be briefly described.

3. Where material amounts of products or services are regularly transferred from one line of business to another, the receiving and transferring lines may be considered a single line of business for the purpose of reporting the operating results thereof.

4. If the method of pricing intracompany transfers of products or services or the method of allocation of common or corporate costs materially affects the reported contribution to income of a line of business, such methods and any material changes between periods in such methods and the effect thereof shall be described briefly.

5. Information regarding sales or revenues or income (or loss) from different classes of products or services in operations regulated by Federal, State or municipal authorities may be limited to those classes of products

or services required by any uniform system of accounts prescribed by such authorities.

VIII. Description of property. Briefly describe carrier revenue equipment, trackage, terminals, and other material tangible equipment and properties. Also describe trackage rights, certificates of public convenience and necessity, and other intangible operating authorities.

Separately describe other properties not used for providing transportation by applicant or its subsidiaries.

Instructions. Provide information which will fairly appraise the potential investor of the scope and potential of applicant's business. Detailed descriptions of the physical characteristics of tangible properties or reproductions of operating authorities are not required and should not be given. Maps, when instructive, should be employed.

IX. Business conditions: regulation. Indicate briefly, to the extent material, the general competitive conditions applicant faces in its transportation services and, where applicable, in its nontransportation enterprises. Discuss any important changes in the technology or type of service applicant or its subsidiaries render to the public. Separate consideration should be given to different regions or modes.

List any material financial restrictions imposed upon applicant or its subsidiaries by the Interstate Commerce Commission to which it may be presently subject. Specify any such restrictions imposed in connection with this issue.

Reproduce the order of the Commission authorizing this issue.

X. Pending legal proceedings. Briefly describe any material pending legal proceedings, other than ordinary routine litigation incidental to the business, to which the applicant or any of its subsidiaries is a party or of which any of their property is the subject. Include the name of the court or agency in which the proceedings are pending, the date instituted and the principal parties thereto. Include similar information as to any such proceedings known to be contemplated by governmental authorities.

Instructions. If the business ordinarily results in actions for negligence or other claims, no such action or claim need be described unless it departs from the normal kind of such actions. Any material bankruptcy, receivership, or similar proceeding with respect to the issuer or any of its significant subsidiaries shall be described. Any material proceedings to which any director, officer, or affiliate of the applicant, or any associate of any such director, officer, or security holder, is a party adverse to the applicant or any of its subsidiaries shall also be described.

XI. Statement of income and earned surplus. Furnish in comparative columnar form a statement of income for each of the last 5 fiscal years of the applicant and for any interim period between the end of the latest of such fiscal years and the date of the latest balance sheet furnished herein, and for the corresponding interim period of the preceding fiscal year. Include comparable data for any additional fiscal years necessary to keep the statement from being misleading. Where necessary, include information or explanation of material significance to investors in appraising the results shown, or refer to such information or explanation set forth elsewhere in the offering circular. An analysis of earned surplus shall be furnished for each period covered by an income statement, as a continuation thereof or elsewhere in the offering circular.

Instructions. 1. If common stock is to be offered, the statements shall be prepared to show earnings applicable to common stock. Per share earnings and dividends declared for each period of the statement shall also

be included and the basis of computation stated.

2. If preferred stock is to be offered, there shall be shown the annual dividend requirements on such preferred stock. To the extent that an issue represents refinancing, only the additional dividend requirements shall be stated.

3. If debt securities are to be issued, the applicant shall show in tabular form for each fiscal year or other period the ratio of earnings to fixed charges. A pro forma ratio of earnings to fixed charges, adjusted to give effect to the issuance of the securities to be registered, and any presently proposed issuance, retirement or redemption of securities, shall also be shown for the latest fiscal year or 12-month period.

4. Statements of income and earned surplus conforming to the foregoing may be furnished on a consolidated basis, but applicant must also present, for the most recent fiscal year, statements of income for each subsidiary (or appropriate groups of subsidiaries).

XII. Description of securities to be issued. If capital stock is to be issued, state the title of the class and furnish the following information:

(a) Outline briefly (1) dividend rights; (2) voting rights; (3) liquidation rights; (4) preemptive rights; (5) conversion rights; (6) redemption provisions; (7) sinking fund provisions; and (8) liability to further calls or to assessment by the applicant.

(b) If the rights of holders of such stock may be modified otherwise than by a vote of a majority or more of the shares outstanding, voting as a class, so state and explain briefly.

(c) If preferred stock is to be issued, outline briefly any restriction on the repurchase or redemption of shares by the issuer while there is any arrearage in the payment of dividends or sinking fund installments. If there is no such restriction, so state.

Instructions. 1. This item requires only a brief summary of the provisions which are pertinent from an investment standpoint. A complete legal description of the provisions referred to is not required and should not be given. Do not set forth the provisions of the governing instruments verbatim; only a succinct résumé is required.

2. If the rights evidenced by the securities are materially limited or qualified by the rights of any other class of securities, include such information regarding such other securities as will enable investors to understand the rights evidenced by the securities to be registered. No information need be given, however, as to any class of securities all of which will be redeemed and retired, provided appropriate steps to assure such redemption and retirement will be taken prior to or upon delivery of the securities to be issued.

3. If the securities described are to be offered pursuant to warrants or rights, state the amount of securities called for by such warrants or rights, the period during which and the price at which the warrants or rights are exercisable.

If debt securities are to be issued, outline briefly such of the following as are relevant:

(a) Provisions with respect to interest, conversion, maturity, redemption, amortization, sinking fund, or retirement.

(b) Provisions with respect to the kind and priority of any lien securing the issue, together with a brief identification of the principal properties subject to such lien.

(c) Provisions with respect to the subordination of the rights of holders of the securities registered to other security holders or creditors of the registrant.

(d) Provisions restricting the declaration of dividends or requiring the maintenance

of any ratio of assets, the creation or maintenance of reserves or the maintenance of properties.

(e) Provisions permitting or restricting the issuance of additional securities, the withdrawal of cash deposited against such issuance, the incurring of additional debt, the release or substitution of assets securing the issue, the modification of the terms of the security, and similar provisions.

Instructions. 1. In the case of secured debt, there should be stated (i) the approximate amount of unsecured property available for use against the issuance of bonds, as of the most recent practicable date, and (ii) whether the securities being issued are to be issued against such property, against the deposit of cash, or otherwise.

2. Provisions permitting the release of assets upon the deposit of equivalent funds or the pledge of equivalent property, the release of property no longer required in the business, obsolete property or property taken by eminent domain, the application of insurance moneys, and similar provisions, need not be described.

(f) The name of the trustee, if any, and the nature of any material relationship with the applicant or any of its affiliates; the percentage of securities of the class necessary to require the trustee to take action, and what indemnification the trustee may require before proceeding to enforce the lien.

(g) The general type of event which constitutes a default and whether or not any periodic evidence is required to be furnished as to the absence of default or as to compliance with the terms of the indenture.

Instruction. The instructions regarding capital stock, as pertinent, shall apply to debt securities.

If securities other than capital stock or debt are to be issued, outline briefly the rights evidenced thereby. If subscription warrants or rights are to be issued, state the title and amount of securities called for, the period during which and the price at which the warrants or rights are exercisable.

Instruction. The instructions regarding capital stock shall also apply to this item.

XIII. Directors and executive officers. List the names of all directors and executive officers of the applicant and all persons chosen to become directors or executive officers. Indicate all positions and offices with the applicant held by each person named, and the principal occupations during the past 5 years of each executive officer and each person chosen to become an executive officer.

Instructions. 1. If any person chosen to become a director or executive officer has not consented to act as such, so state.

2. For the purpose of this item, the term "executive officer" means the president, vice president, secretary and treasurer, and any other officer who performs similar policymaking functions for the applicant.

XIV. Remuneration of directors and officers. (a) Furnish the following information in substantially the tabular form indicated below as to all direct remuneration paid by the applicant and its subsidiaries during the applicant's last fiscal year to the following persons for services in all capacities:

(1) Each director, and each of the three highest paid officers, of the applicant whose aggregate direct remuneration exceeded \$30,000, naming each such person.

(2) All directors and officers of the applicant as a group, without naming them.

(A)	(B)	(C)
Name of individual or identity of group	Capacities in which remuneration was received	Aggregate direct remuneration

Instructions. 1. This item applies to any person who was a director or officer of the applicant at any time during the period specified. However, information need not be given for any portion of the period during which such person was not a director or officer of the applicant.

2. The information is to be given on an accrual basis if practicable. The tables required by this paragraph and paragraph (b) may be combined if the applicant so desires.

3. Do not include remuneration paid to a partnership in which any director or officer was a partner, but see item XVII.

4. If the applicant has not completed a full fiscal year since its organization or if it acquired or is to acquire the majority of its assets from a predecessor within the current fiscal year, the information shall be given for the current fiscal year, estimating future payments, if necessary. To the extent that such remuneration is to be computed upon the basis of a percentage of profits, it will suffice to state such percentage without estimating the amount of such profits to be paid.

5. If any part of the remuneration shown in response to this item was paid pursuant to a material bonus or profit-sharing plan, briefly describe the plan and the basis upon which directors or officers participate therein. See Instructions 1 to paragraph (b) for the meaning of the term plan.

(b) Furnish the following information, in substantially the tabular form indicated below, as to all pension or retirement benefits proposed to be paid under any existing plan in the event of retirement at normal retirement date, directly or indirectly, by the applicant or any of its subsidiaries to each director or officer named in answer to paragraph (a) (1) above:

(A)	(B)	(C)
Name of individual	Amounts set aside or accrued during applicant's last fiscal year	Estimated annual benefits upon retirement

Instructions. 1. The term "plan" in this item includes all plans, contracts, authorizations, or arrangements, whether or not set forth in any formal document.

2. Column (B) need not be answered with respect to amounts computed on an actuarial basis under any plan which provides for fixed benefits in the event of retirement at a specified age or after a specified number of years of service.

3. The information called for by Column (C) may be given in a table showing the annual benefits payable upon retirement to persons in specified salary classifications.

4. In the case of any plan (other than those specified in Instructions 2) where the amount set aside each year depends upon the amount of earnings of the applicant or its subsidiaries for such year or a prior year, or where it is otherwise impracticable to state the estimated annual benefits upon retirement, there shall be set forth, in lieu of the information called for by Column (C), the aggregate amount set aside or accrued to date, unless it is impracticable to do so, in which case there shall be stated the method of computing such benefits.

(c) Describe briefly all remuneration payments (other than payments reported under paragraph (a) or (b) of this item) proposed to be made in the future, directly or indirectly, by the applicant or any of its subsidiaries pursuant to any existing plan or arrangement to (i) each director or officer named in answer to paragraph (a) (1), naming each such person, and (ii) all directors

and officers of the applicant as a group, without naming them.

Instruction. Information need not be included as to payments to be made for, or benefits to be received from, group life or accident insurance, group hospitalization or similar group payments or benefits. If it is impracticable to state the amount of remuneration payments proposed to be made, the aggregate amount set aside or accrued to date in respect of such payments should be stated, together with an explanation of the basis for future payments.

XV. Options to purchase securities. Furnish the following information as to options to purchase securities from the applicant or any of its subsidiaries, which are outstanding as of a specified date within 30 days prior to the date of filing.

(a) Describe the options, stating the material provisions including the consideration received and to be received for such options by the grantor thereof and the market value of the securities called for on the granting date. If, however, the options are "qualified stock options," or "restricted stock options" or options granted pursuant to a plan qualifying as an "employee stock purchase plan," as those terms are defined in sections 422 through 424 of the Internal Revenue Code of 1954, as amended, only the following is required: (i) A statement to the effect, (ii), a brief description of the terms and conditions of the options or of the plan pursuant to which they were issued, and (iii) a statement of the provisions of the plan or options with respect to the relationship between the option price and the market price of the securities at the date when the options were granted, or with respect to the terms of any variable price option.

(b) State (i) the title and amount of securities called for by such options; (ii) the purchase prices of the securities called for and the expiration dates of such options; and (iii) the market value of the securities called for by such options as of the latest practicable date.

Instruction. In case a number of options are outstanding having different prices and expiration dates, the options may be grouped by prices and dates. If this produces more than five separate groups then there may be shown only the range of the expiration dates and the average purchase prices, i.e., the aggregate purchase price of all securities of the same class called for by all outstanding options to purchase securities of that class divided by the number of securities of such class so called for.

(c) Furnish separately the information called for by paragraph (b) above for all options held by (i) each director or officer named in answer to paragraph (a) (1) of item XIV naming each such person, and (ii) all directors and officers as a group without naming them.

Instructions. 1. The term "options" as used in this item includes all options, warrants and rights other than those issued to security holders as such on a pro rata basis.

2. The extension of options shall be deemed the granting of options within the meaning of this item.

3. Where the total market value of securities called for by all outstanding options as of the specified date referred to in this item does not exceed \$10,000 for any officer or director named in answer to paragraph (a) (1) of Item 17, or \$30,000 for all officers and directors as a group, or for all option holders as a group, this item need not be answered with respect to options held by such person or group.

XVI. Principal holders of securities. Furnish the following information as of a specified date within 90 days prior to the date of filing in substantially the tabular form indicated:

(a) As to the voting securities of the applicant owned of record or beneficially by each person who owns of record, or is known by the applicant to own beneficially, more than 10 percent of any class of such securities. Show in Column (3) whether the securities are owned both of record and beneficially, of record only, or beneficially only, and show in Columns (4) and (5) the respective amounts and percentages owned in each such manner:

(1)	(2)	(3)	(4)	(5)
Name and address	Title of class	Type of ownership	Amount owned	Percent of class

(b) As to each class of equity securities of the applicant or any of its parents or subsidiaries, other than directors' qualifying shares, beneficially owned directly or indirectly by all directors and officers of the applicant, as a group, without naming them.

(1)	(2)	(3)
Title of class	Amount beneficially owned	Percent of class

Instructions. 1. The percentages are to be calculated on the basis of the amount of outstanding securities, excluding securities held by or for the account of the issuer. In any case where the amount owned by directors and officers as a group is less than 1 percent of the class, the percent of the class owned by them may be omitted.

2. If the equity securities are being issued in connection with, or pursuant to, a plan of acquisition, reorganization, readjustment or succession, indicate, as far as practicable, the status to exist upon consummation of the plan on the basis of present holdings and commitments.

3. If any of the securities being issued are to be offered for the account of security holders, name each such security holder and state the amount of the securities owned by him, the amount to be offered for his account, and the amount to be owned after the offering.

4. If, to the knowledge of the applicant or any principal underwriter of the securities being issued, more than 10 percent of any class of voting securities of the applicant are held or are to be held subject to any voting trust or other similar agreement, state the title of such securities, the amount held or to be held and the duration of the agreement. Give the names and addresses of the voting trustees and outline briefly their voting rights and other powers under the agreement.

XVII. Interest of management and others in certain transactions. Describe briefly, and where practicable, state the approximate amount of any material interest, direct or indirect, of any of the following persons in any material transaction during the last 3 years, or in any material proposed transactions, to which the applicant, or a person in control of applicant as defined in Item VII or any of its subsidiaries was, or is to be, a party:

- (a) Any director or officer of the applicant;
- (b) Any security holder named in answer to XVI(a);
- (c) Any person listed in Item VII.

(d) Any associate of any of the foregoing persons.

Instructions. 1. See Instruction 1 to Item XIV(a). Include the name of each person whose interest in any transaction is described and the nature of the relationship by reason of which such interest is required to be described. Where it is not practicable to state the approximate amount of the interest, the approximate amount involved in the transaction shall be indicated.

2. As to any transaction involving the purchase or sale of assets by or to the applicant or any subsidiary, otherwise than in the ordinary course of business, state the cost of the assets to the purchaser and the cost thereof to the seller if acquired by the seller within 2 years prior to the transaction.

3. This item does not apply to any interest arising from the ownership of securities of the applicant where the security holder receives no extra or special benefit not shared on a pro rata basis by all other holders of the same class.

4. No information need be given in answer to this item as to any remuneration not received during the applicant's last fiscal year or as to any remuneration or other transaction disclosed in response to Items XIV or XV.

5. Information should be included as to any material underwriting discounts and commissions upon the sale of securities by the applicant where any of the specified persons was or is to be a principal underwriter or is a controlling person, or member, of a firm which was or is to be a principal underwriter. Information need not be given concerning ordinary management fees paid by underwriters to a managing underwriter pursuant to an agreement among underwriters the parties to which do not include the applicant or its subsidiaries.

6. No information need be given in answer to this item as to any transaction or any interest therein where:

(i) The rates or charges involved in the transaction are fixed by law or determined by competitive bids;

(ii) The interest of the specified persons in the transaction is solely that of a director of another unaffiliated corporation which is a party to the transaction;

(iii) The transaction involves services as a bank depository of funds, transfer agent, registrar, trustee under a trust indenture, or other similar services;

(iv) The interest of the specified persons, including all periodic installments in the case of any lease or other agreement providing for periodic payments or installments, does not exceed \$30,000;

(v) The transaction does not involve remuneration for services, directly or indirectly, and (a) the interest of the specified persons arises from the ownership individually and in the aggregate of less than 10 percent of any class of equity securities of another corporation which is a party to the transaction, (b) the transaction is in the ordinary course of business of the applicant or its subsidiaries, and (c) the amount of such transaction or series of transactions is less than 10 percent of the total sales or purchases, as the case may be, of the applicant and its subsidiaries.

7. Information shall be furnished in answer to this item with respect to transactions not excluded above which involve remuneration, directly or indirectly, to any of the specified persons for services in any capacity unless the interest of such persons arises solely from the ownership individually and in the aggregate of less than 10 percent of any class of equity securities of another corporation furnishing the services to the applicant or its subsidiaries.

8. This item does not require the disclosure of any interest in any transaction unless such interest and transaction are material.

XVIII. Other financial statements and "balance sheets" schedules. (a) There shall be furnished a balance sheet of the applicant and a consolidated balance sheet of the applicant and its subsidiaries as of a date within 6 months prior to the date of filing the application.

Instructions. The individual balance sheets of the applicant may be omitted if (1) consolidated balance sheets of the applicant and one or more of its subsidiaries are furnished, (ii) either one of the following conditions is met, and (iii) the Commission is advised as to the reasons for such omission:

(1) The applicant is primarily an operating company and all subsidiaries included in the consolidated balance sheets furnished are totally-held subsidiaries; or

(2) The applicant's total assets, exclusive of investments in and advances to the consolidated subsidiaries, constitute 85 percent or more of the total assets shown by the consolidated balance sheets filed and the applicant's total gross revenues for the period for which its profit and loss statements would be filed, exclusive of interest and dividends received from the consolidated subsidiaries, constitute 85 percent or more of the total gross revenue shown by the consolidated profit and loss statements filed.

(b) There shall be furnished for each majority-owned subsidiary of the applicant not included in the consolidated statements, the balance sheets which would be required if the subsidiary were itself an applicant. If the applicant owns, directly or indirectly, approximately 50 percent of the voting securities of any person and approximately 50 percent of the voting securities of such person is owned, directly or indirectly, by another single interest, there shall be filed for each such person the balance sheets which would be required if it were an applicant. The statements filed for each such person shall identify the other single interest. Where appropriate, group statements may be filed for such persons.

Instructions. 1. Insofar as practicable, these balance sheets shall be as of the same dates as those of the applicant.

2. There may be omitted all balance sheets of any one or more unconsolidated subsidiaries or 50 percent owned persons if all such subsidiaries and persons whose balance sheets are so omitted, considered in the aggregate as a single subsidiary, would not constitute a significant subsidiary.

(c) (1) There shall be filed for any business directly or indirectly acquired by the applicant after the date of the latest balance sheet filed pursuant to (a) above and for any business to be directly or indirectly acquired by the applicant, the financial statements which would be required if such business were an applicant.

(2) The acquisition of securities shall be deemed to be the acquisition of a business if such securities give control of the business or combined with securities already held give such control.

(3) No financial statements need be filed, however, for any business acquired or to be acquired from a totally-held subsidiary. In addition, the statements of any one or more business may be omitted if such businesses, considered in the aggregate as a single subsidiary, would not constitute a significant subsidiary.

APPENDIX II

REGION 1

Regional Manager Robert L. Abare, Interstate Commerce Commission, John Fitzgerald Kennedy Building, Government Center, Room 2211B, Boston, Mass. 02203.

REGION 2

Regional Manager Fred E. Cochran, Interstate Commerce Commission, 16th Floor, 1518 Walnut Street, Philadelphia, PA 19102.

REGION 3

Regional Manager James B. Weber, Interstate Commerce Commission, 1252 West Peachtree Street, Northwest, Room 300, Atlanta, GA 30309.

REGION 4

Regional Manager Charles W. Haas, Interstate Commerce Commission, Everett McKinley Dirksen Building, Room 1086, 219 South Dearborn Street, Chicago, IL 60604.

REGION 5

Regional Manager Harold M. Gregory, Interstate Commerce Commission, 9A27 Fritz Garland Lanham, Federal Building, 819 Taylor Street, Fort Worth, TX 76102.

REGION 6

Regional Manager Ernest D. Murphy, Interstate Commerce Commission, 13001 Federal Building, 450 Golden Gate Avenue, Post Office Box 36004, San Francisco, CA 94102.

[FR Doc.71-16478 Filed 11-11-71;8:45 am]

Notices

DEPARTMENT OF THE TREASURY

Comptroller of the Currency

BANK OF CALIFORNIA, N. A.

Notice of Application for Unlisted Trading Privileges

NOVEMBER 8, 1971.

Notice is hereby given that the Philadelphia-Baltimore-Washington Stock Exchange, 17th Street and Stock Exchange Place, Philadelphia, PA 19103, has filed an application with the Comptroller of the Currency, pursuant to section 12(f) (1) (B) of the Securities Exchange Act of 1934, as amended, for unlisted trading privileges in the common stock of the Bank of California, N. A., San Francisco, Calif., which securities are listed and registered on the New York Stock Exchange.

Notice is hereby given that any interested person may, not later than November 30, 1971, at 5:30 p.m., submit to the Comptroller of the Currency in writing a request for a hearing on the matter accompanied by a statement as to the nature of his interest, the reason for such request and the issues of fact or law proposed to be controverted, or he may request that he be notified if the Comptroller should order a hearing thereon. Any such communication should be addressed: Office of the Comptroller of the Currency, Attention: Mr. Robert Bloom, Chief Counsel, Treasury Building, Washington, D.C. 20220. A copy of such request shall be served personally or by mail (airmail if the person being served is located more than 500 miles from the point of mailing) upon applicant at the address stated above. Proof of such service (by affidavit or in case of attorney at law by certificate) shall be filed contemporaneously within the request. At any time after said date, an order disposing of the application herein may be issued by the Comptroller of the Currency upon the basis of the information stated in the application, unless an order for hearing upon said application shall be issued upon request or upon the Comptroller's own motion. Persons who request a hearing or advice as to whether a hearing is ordered will receive notice of further developments in this matter, including the date of the hearing (if ordered) and any postponements thereof.

[SEAL] WILLIAM B. CAMP,
Comptroller of the Currency.

[FR Doc.71-16585 Filed 11-11-71;8:51 am]

Fiscal Service BUREAU OF ACCOUNTS

Statement of Organization, Functions and Procedures

In order to reflect organizational changes in the Bureau of Accounts since publication of the Statement of Organization, Functions and Procedures Available published in the FEDERAL REGISTER of September 24, 1969 (34 F.R. 14738-39), section 3 thereof is revised to read as follows:

Sec. 3. Bureau of Accounts—(a) Generally. (1) The Bureau of Accounts, under the Commissioner of Accounts, was created and established as a part of the Fiscal Service by Reorganization Plan No. III, effective June 30, 1940, with the responsibility for a variety of fiscal activities of Government-wide scope.

(2) The Bureau maintains principal offices in Washington, D.C.; they include the Division of Disbursement, the Division of Financial Management, the Division of Government Financial Operations, and the Division of Cash Management. The field offices of the Division of Disbursement are set forth in paragraph (b).

(3) The regulations of the Bureau are codified at 31 CFR, Subtitle B, Chapter II, Subchapter A.

(b) *Division of Disbursement.* The Division is responsible for the function of disbursement of moneys of the United States in relation to all civilian agencies of the executive branch, except the Postal Service, U.S. Marshals, and certain Government corporations, pursuant to section 4 of Executive Order 6166 of June 10, 1933, as amended (5 U.S.C.A. 901 note). Disbursing activities are carried out (i) through eight major disbursing centers, and four regional disbursing offices of the Division located in the United States and Manila, Philippine Islands, and (ii) by delegation, through facilities of the Department of State and other agencies located in certain foreign countries. The disbursing centers are as follows:

Disbursing center	Address	Director
Austin, Tex. 78741	1619 East Woodward St.	George L. Clark.
Birmingham, Ala. 35203	2225 3rd Ave., North.	Randolph Mobbs.
Chicago, Ill. 60689	536 South Clark St.	Robert Pacheco.
Denver, Colo. 80225	Bldg. 53, Denver Federal Center.	G. Lewis Frazer.
Kansas City, Mo. 64142	811 Grand Ave.	Robert L. Larson.
Philadelphia, Pa. 19101	5000 Wissahickon Ave.	Robert L. Langdon.
San Francisco, Calif. 94105	390 Main St.	P. Edward Frowd.
Washington, D.C. 20013	411 G Street NW.	Henry H. Eades.

Regional disbursing office	Address	Disbursing officer
Honolulu, Hawaii 96813	335 South King St.	Elde H. Chang.
Anchorage, Alaska 99501	Federal Bldg., 4th and F Sts.	Patricia I. Handelin.
Manila, Philippine Island, 96528	200 New Office Bldg., American Embassy.	Richard W. Homer.
New York, N.Y. 10001	341 9th Ave.	Louis Kirschner.

(c) Division of Financial Management.

(1) The Division performs the comptrollership functions of the Bureau. In addition it furnishes representation of the Department of the Treasury on the Steering Committee for the Joint Financial Management Improvement program in the Federal Government (31 U.S.C. 65(f)) and provides staff assistance to the Committee on joint program projects.

(2) The Division conducts the liquidation of certain programs which were transferred to the Secretary of the Treasury under the provisions of the Reconstruction Finance Corporation Liquidation Act, as amended (67 Stat. 230), Executive Order 10489 of September 26, 1953 (18 F.R. 6201), and Reorganization Plan No. 1 of 1957 (5 U.S.C.A. App.). These involve the lending programs conducted under section 409 of the Federal Civil Defense Act of 1950, as amended (50 U.S.C. App. 2261), and section 302 of the Defense Production Act of 1950, as amended (50 U.S.C. App. 2092), consisting of business loans with individual balances of \$250,000 or more, securities of and loans to railroads, and securities of financial institutions.

(3) In accord with 31 CFR Parts 223-226, the Division supervises matters arising under title 6 of the United States Code relating to surety companies authorized as acceptable sureties on Federal bonds, including the examination of applications of companies requesting authority from the Secretary of the Treasury to write such bonds, and the review of the financial statements of companies so authorized, in order to determine their compliance with Treasury requirements and related underwriting limitations.

(4) 31 CFR Part 256 sets forth the Division's functions in receiving applications from and making payments to persons entitled to sums appropriated by the Congress in private relief acts and, in conjunction with the Division of Disbursement, in making payments to persons securing money judgments against the United States in the Court of Claims or in the Federal district courts.

(5) The Division performs duties relating to foreign obligations, consisting generally of the collection of the principal and interest on obligations due from foreign governments under lend-lease (Executive Order 9726, dated May 17, 1946), surplus property and other agreements, and the keeping of related accounts.

(6) The Division performs the Department's duties relating to awards under the Settlement of War Claims Act of 1928, as amended (45 Stat. 254), the War Claims Act of 1948, as amended (50 U.S.C. App. 2001 et seq.), and the International Claims Settlement Act of 1949, as amended (22 U.S.C. 1621 et seq.). The duties include payment on such awards and the keeping of accounts therefor. Department Circular 881 (31 CFR Part 250) and 31 CFR Part 251 set forth the regulations under the 1949 Act, as amended.

(7) Pursuant to the Act of March 28, 1966 (80 Stat. 92), providing for the discontinuance of the Postal Savings System, postal savings funds are held in a trust fund account subject to claims by depositors or their successors in interest. The Division processes these claims and effects payment thereof.

(8) The Division administers certain of the duties of the Secretary of the Treasury, relating to shipment of valuables and handling claims for losses, under the Government Losses in Shipment Act, as amended (40 U.S.C. 721 et seq.).

(d) *Division of Government Financial Operations.* (1) The Division administers a unified system of central accounting for the Government under the Accounting and Auditing Act of 1950, as amended (31 U.S.C. 65 et seq.). Through this system, the central accounts of the Government provide the accounting basis for compiling receipt and expenditure data for financial statements of the Government as a whole.

(2) The Division plans and develops for publication periodic and special reports presenting the results of the financial operations of the Government and handles the accounting and reporting for those foreign currencies acquired by the Government without purchase with dollars.

(3) The Division maintains the investment accounts of the Government and processes loans to Government agencies made pursuant to statute. In connection therewith, it arranges for the custody of investments and securities held by the Treasurer and by Federal Reserve Banks for which the Secretary of the Treasury is responsible.

(4) The Division also works with staff of the Office of Management and Budget and the General Accounting Office in the Joint Financial Management Improvement Program on Government-wide matters relating to accounting systems.

(e) *Division of Cash Management.* (1) The Division provides direction and technical guidance for cash flow of the Federal Government, including the oversight function of management and utilization

of foreign currencies acquired by the U.S. Government.

(2) The Division prescribes fiscal requirements and approves agency systems for the financing of Federal advances by letter of credit; it also oversees cash procedures of agencies and accountable officers in the application of the letter-of-credit procedure.

(3) The Division administers matters relating to the designation and qualification of Government depositories and the deposit of Government funds with them. The depositories include banks which are depositories under Department Circular 176 (31 CFR Part 202), or special depositories under Department Circular 92 (31 CFR Part 203); and foreign depositories.

(4) The Division supervises, in conjunction with the Federal Reserve banks in their capacity as fiscal agents of the United States, the designation and qualification of banks, as Depositories for Federal Taxes, to receive deposits of certain Federal taxes on employers and employees and withheld income taxes on wages; and the authorization of such depositories to receive deposits of Federal corporate income taxes, all under Department Circular 1079 (31 CFR Part 214); the Division also handles certain administrative matters in connection with the Federal Tax Deposit System.

Dated: November 2, 1971.

[SEAL] JOHN K. CARLOCK,
Fiscal Assistant Secretary.

[FR Doc.71-16586 Filed 11-11-71; 8:51 am]

Internal Revenue Service

[Order 120]

APPELLATE CONFEREES

Delegation of Authority in Protested Cases and in Tax Court Cases

1. Pursuant to the authority vested in the undersigned it is ordered that:

a. Each appellate conferee in Houston and New Orleans appellate branch offices in Southwest region, Boston, Buffalo, and New Haven appellate branch offices in North Atlantic region, and Baltimore, Philadelphia, and Richmond appellate branch offices in mid-Atlantic region is authorized to exercise the authorities granted to appellate officials in the following delegation orders (as revised):

Delegation order No.	Subject
8-----	Authority to sign agreements as to liability for personal holding company tax
35-----	Agreements as determinations under section 1313(a)(4) of the Internal Revenue Code of 1954
66-----	Authorities of regional appellate division and of regional counsel in protested cases and in tax court cases
75-----	Authority of regional appellate division in offers in compromise
77-----	Authority to issue statutory notices of deficiency

Delegation order No.	Subject
93-----	Authority to consent to a re-determination of aggregations by a taxpayer in the case of invalid basic aggregations or invalid additions
97-----	Closing agreements concerning internal revenue tax liability
107-----	Authority to determine that certain "savings institutions" do not intend to avoid taxes by paying dividends or interest for periods representing more than 12 months
109-----	Authority to sign agreements determining inapplicability of exclusion under section 963 of Internal Revenue Code of 1954

2. The authority delegated herein may not be redelegated.

Date of issue: November 11, 1971.

Effective date: January 1, 1972.

[SEAL] JOHNNIE M. WALTERS,
Commissioner.

[FR Doc.71-16556 Filed 11-11-71; 8:49 am]

DEPARTMENT OF THE INTERIOR

Geological Survey

[Powersite Cancellation 306]

COWLITZ RIVER, WASH.

Powersite Cancellation

Pursuant to authority under the Act of March 3, 1879 (20 Stat. 394; 43 U.S.C. 31), and 220 Departmental Manual 6.1, Powersite Classification 75 of June 6, 1924, is hereby canceled to the extent that it affects the following described land:

WILLAMETTE MERIDIAN

T. 13 N., R. 9 E.,
Sec. 1, lot 1.

The area described aggregates about 2 acres.

Dated: November 5, 1971.

W. A. RADLINSKI,
Acting Director.

[FR Doc.71-16538 Filed 11-11-71; 8:47 am]

[Powersite Cancellation 309]

NEW FORK RIVER BASIN, WYO.

Powersite Cancellation

Pursuant to authority under the Act of March 3, 1879 (20 Stat. 394; 43 U.S.C. 31), and 220 Departmental Manual 6.1, Powersite Classification 8 of November 3, 1921, is hereby canceled to the extent that it affects the following described land:

SIXTH PRINCIPAL MERIDIAN

T. 33 N., R. 108 W.,
Sec. 10, SW $\frac{1}{4}$ SW $\frac{1}{4}$.

T. 34 N., R. 108 W.,
Sec. 26, S $\frac{1}{2}$ SE $\frac{1}{4}$;

Sec. 34, lot 3, S $\frac{1}{2}$ NE $\frac{1}{4}$, SE $\frac{1}{4}$ NW $\frac{1}{4}$, NE $\frac{1}{4}$ SW $\frac{1}{4}$, and N $\frac{1}{2}$ SE $\frac{1}{4}$;
Sec. 35, SW $\frac{1}{4}$ NW $\frac{1}{4}$.

The area described aggregates about 402 acres.

Dated: November 5, 1971.

W. A. RADLINSKI,
Acting Director.

[FR Doc.71-16539 Filed 11-11-71;8:47 am]

DEPARTMENT OF AGRICULTURE

Office of the Secretary

ADMINISTRATOR, AGRICULTURAL
RESEARCH SERVICE

Delegation of Authority to Appoint Uniformed Armed Guards as Special Policemen

In accordance with the authority delegated to me by the Secretary of Agriculture, the Administrator of the Agricultural Research Service is hereby authorized to appoint uniformed armed guards as special policemen, to make all needful rules and regulations, and to annex to such rules and regulations such reasonable penalties, not to exceed those prescribed in 40 U.S.C. 318c, as will ensure their enforcement, for the protection of the buildings and grounds of the Arboretum, Washington, D.C., the U.S. Meat Animal Research Center, Clay Center, Nebr., and the U.S. Agricultural Research Center, Beltsville, Md., over which the United States has exclusive or concurrent criminal jurisdiction. The Administrator may redelegate the authority to appoint uniformed armed guards to any Agricultural Research officer or employee.

Any rules or regulations promulgated under the authority herein granted shall be approved by the Director of Plant and Operations and the General Counsel prior to issuance.

This authority shall be exercised in accordance with the limitations and requirements of the Federal Property and Administrative Services Act of 1949 (63 Stat. 377), as amended, the Act of June 1, 1948 (62 Stat. 281), as amended, and the policies, procedures and controls prescribed by the General Services Administration.

NED D. BAYLEY,
Director, Science and Education.

NOVEMBER 9, 1971.

[FR Doc.71-16587 Filed 11-11-71;8:51 am]

DIRECTOR, SCIENCE AND EDUCATION

Delegation of Authority To Appoint Uniformed Armed Guards as Special Policemen

In accordance with authorities delegated to me by the Administrator of the General Services Administration (34 F.R. 6406) (36 F.R. 1293) and (36 F.R. 18440) on April 4, 1969, January 20, 1971, and

September 8, 1971, the Director of Science and Education is hereby authorized to appoint uniformed armed guards as special policemen, to make all needful rules and regulations, and to annex to such rules and regulations such reasonable penalties, not to exceed those prescribed in 40 U.S.C. 318c, as will insure their enforcement, for the protection of the buildings and grounds of the Arboretum, Washington, D.C., and the U.S. Meat Animal Research Center, Clay Center, Nebr., and the U.S. Agricultural Research Center, Beltsville, Md., over which the United States has exclusive or concurrent criminal jurisdiction. The Director may redelegate this authority to any officer or employee under his jurisdiction.

Any rules or regulations promulgated under the authority herein granted shall be approved by the Director of Plant and Operations and the General Counsel prior to issuance.

This authority shall be exercised in accordance with the limitations and requirements of the Federal Property and Administrative Services Act of 1949 (63 Stat. 377), as amended, the Act of June 1, 1948 (62 Stat. 281), as amended, and the policies, procedures and controls prescribed by the General Services Administration.

This delegation supersedes the delegation to the Administrator, Agricultural Research Service, dated May 2, 1969, and appearing at 34 F.R. 7389 on May 7, 1969.

J. PHIL CAMPBELL,
Acting Secretary of Agriculture.

NOVEMBER 3, 1971.

[FR Doc.71-16588 Filed 11-11-71;8:51 am]

SOUTH CAROLINA

Designation of Areas for Emergency Loans

For the purpose of making emergency loans pursuant to section 321 of the Consolidated Farmers Home Administration Act of 1961 (7 U.S.C. 1961) and section 232 of the Disaster Relief Act of 1970 (Public Law 91-606), it has been determined that in the following county in the State of South Carolina natural disasters have caused a general need for agricultural credit:

COUNTY
Lee

Emergency loans will not be made in the above-named county under this designation pursuant to applications received after June 30, 1972, except subsequent loans to qualified borrowers who received initial loans under this designation.

The urgency of the need for emergency loans in the designated areas makes it impracticable and contrary to the public interest to give advance notice of proposed rule making and invite public participation.

Done at Washington, D.C., this 9th day of November 1971.

J. PHIL CAMPBELL,
Acting Secretary.

[FR Doc.71-16552 Filed 11-11-71;8:48 am]

ATOMIC ENERGY COMMISSION

[Dockets Nos. 50-400, 50-401, 50-402, 50-403]

CAROLINA POWER & LIGHT CO.

Notice of Receipt of Application for Construction Permits and Facility Licenses; Time for Submission of Views on Antitrust Matters

Carolina Power & Light Co., 336 Fayetteville Street, Raleigh, NC 27602, pursuant to section 103 of the Atomic Energy Act of 1954, as amended, filed an application on September 7, 1971, for authorization to construct and operate four pressurized water nuclear reactors designated as Shearon Harris Nuclear Power Plant, units 1, 2, 3, and 4, on the applicant's site in Wake and Chatham Counties, N.C.

The site is located on approximately 18,000 acres of land in the southwest corner of Wake County, and the southeast corner of Chatham County, N.C. The city of Raleigh, N.C., is approximately 20 miles northeast of the site, and Sanford, N.C., is about 10 miles southwest. The applicant will construct a dam on Buckhorn Creek about 1 mile north of its confluence with the Cape Fear River. This dam will create a 10,000 acre reservoir which will be used for cooling water requirements for the plant. The nuclear units will be located on a peninsula on the northwest shore of the reservoir about 3½ miles north of the main dam.

Each of the four units will be designed for an initial power output of 2,785 megawatts thermal, with an equivalent net electrical output of approximately 900 megawatts electrical.

Any person who wishes to have his views on the antitrust aspects of the application presented to the Attorney General for consideration shall submit such views to the Commission within sixty (60) days after October 22, 1971.

A copy of the application is available for public inspection at the Commission's Public Document Room, 1717 H Street NW., Washington, D.C., and a copy has been sent to Mr. H. Williams O'Shea, Director, Wake County Public Libraries, 104 Fayetteville Street, Raleigh, NC 27601.

Dated at Bethesda, Md., this 29th day of September 1971.

For the Atomic Energy Commission.

PETER A. MORRIS,
Director,
Division of Reactor Licensing.

[FR Doc.71-14582 Filed 10-21-71;8:45 am]

SAFETY GUIDES

Notice of Issuance

The Atomic Energy Commission has issued five new safety guides which have been developed to provide guidance on the acceptability of specific safety-related features of water cooled nuclear power plants and one supplement to a previously-issued guide that provides guidance concerning possible backfitting.

A total of 18 safety guides has been completed since the Commission, on November 13, 1970, announced development of a series of these guides. Four were made available then and nine more on April 9, 1971.

The primary purpose of the safety guides is to make available to the industry positions that have been developed by the Regulatory Staff and the Commission's Advisory Committee on Reactor Safeguards on safety issues. Although the safety guides are not regulatory requirements, they do specifically identify safety issues that should be considered in the design and in the evaluation of water cooled nuclear power plants and describe a set of principles and specifications which will represent an acceptable solution to the Regulatory Staff and Advisory Committee on Reactor Safeguards on these issues. Their use by an applicant will expedite the licensing review process.

Titles of the new guides are:

Safety Guide 14—Reactor Coolant Pump Flywheel Integrity.

Safety Guide 15—Testing of Reinforcing Bars for Concrete Structures.

Safety Guide 16—Reporting of Operating Information.

Safety Guide 17—Protection Against Industrial Sabotage.

Safety Guide 18—Structural Acceptance Test for Concrete Primary Reactor Containments.

Supplement to Safety Guide 7—Control of Combustible Gas Concentrations in Containment Following a Loss of Coolant Accident—Backfitting Considerations.

Other safety guides currently being developed include the following:

Assumptions Used for Evaluating the Potential Radiological Consequences of a Fuel Handling Accident for Boiling and Pressurized Water Reactors.

Vibration Monitoring.

Radioactive Gas Storage Tank Failure Assumptions.

Reactor Coolant Pressure Boundary Leakage Detection.

Measuring and Reporting of Effluents from Nuclear Power Plants.

Quality Assurance for Design of Nuclear Power Plants.

Nondestructive Examination of Primary Reactor Containment Liners.

Ultimate Heat Sink.

Comments and suggestions for improvements in the guides are encouraged. Comments and requests for copies of the guides should be sent to the Director, Division of Reactor Standards, U.S. Atomic Energy Commission, Washington, D.C. 20545.

(5 U.S.C. 552(a))

Dated at Bethesda, Md., this 4th day of November 1971.

For the Atomic Energy Commission.

L. MANNING MUNTZING,
Director of Regulation.

[FR Doc.71-16531 Filed 11-11-71;8:46 am]

INFORMATION GUIDES

Notice of Issuance

The Atomic Energy Commission has issued a new series of information guides to identify specific technical information needed in the AEC's licensing review.

In the reactor licensing process, applicants are requested by the regulatory staff to submit additional technical information needed in the licensing review that has not been submitted in the original application. Much of this information must be requested of each applicant after the application has been reviewed to determine if the needed information has been supplied. The process of reviewing each application for this missing information and requesting its submission from each individual applicant is time consuming. There is need for an expeditious means to provide additional guidance to prospective applicants as to information needed in the review process.

To help solve this problem, the Director of Regulations has established a new series of information guides that will specify much of the information requested repeatedly of all applicants for water-cooled nuclear powerplants. The purpose of the information guides is to provide guidance to applicants and prospective applicants concerning certain of the information that will be needed as part of the licensing review of all power reactor applications.

Comments on the guides are encouraged. Comments and requests for copies should be addressed to the Director, Division of Reactor Standards, U.S. Atomic Energy Commission, Washington, D.C. 20545.

(5 U.S.C. 552(a))

Dated at Bethesda, Md., this 4th day of November 1971.

For the Atomic Energy Commission.

L. MANNING MUNTZING,
Director of Regulation.

[FR Doc.71-16532 Filed 11-11-71;8:46 am]

DEPARTMENT OF HOUSING
AND URBAN DEVELOPMENT

[Docket No. D-71-133]

DEPUTY REGIONAL ADMINISTRATOR,
ET AL., REGION III (PHILADELPHIA)

Designation To Serve as Acting
Regional Administrator

The officials appointed to the following listed positions in Region III (Phila-

delphia) are hereby designated to serve as Acting Regional Administrator, Region III (Philadelphia), during the absence of the Regional Administrator, with all the powers, functions, and duties re-delegated or assigned to the Regional Administrator; *Provided*, That no official is authorized to serve as Acting Regional Administrator unless all other officials whose titles precede his in this designation are unable to act by reason of absence or vacancy in the position:

1. Deputy Regional Administrator.
2. Regional Counsel.
3. Assistant Regional Administrator for Administration.
4. Assistant Regional Administrator for Housing Management.
5. Assistant Regional Administrator for Community Planning and Management.
6. Assistant Regional Administrator for Community Development.
7. Assistant Regional Administrator for Housing Production and Mortgage Credit.
8. Assistant Regional Administrator for Equal Opportunity.

This designation supersedes the designation effective March 25, 1969 (34 F.R. 6708, April 19, 1969).

(Redelegation of authority to take final action with respect to certain positions and employees effective as of May 4, 1969.)

Effective as of the 1st day of October 1971.

THEODORE R. ROSS,
Regional Administrator,
Region III.

[FR Doc.71-16566 Filed 11-11-71;8:49 am]

CIVIL SERVICE COMMISSION

DEPARTMENT OF THE INTERIOR

Notice of Revocation of Authority to
Make Noncareer Executive Assign-
ment

Under authority of § 9.20 of Civil Service Rule IX (5 CFR 9.20), the Civil Service Commission revokes the authority of the Department of the Interior to fill by noncareer executive assignment in the excepted service the position of Assistant to the Secretary, Office of the Secretary, Secretary's Immediate Office.

UNITED STATES CIVIL SERVICE
COMMISSION,

[SEAL] JAMES C. SPRY,
Executive Assistant
to the Commissioners.

[FR Doc.71-16579 Filed 11-11-71;8:50 am]

DEPARTMENT OF THE INTERIOR

Notice of Revocation of Authority to
Make Noncareer Executive Assign-
ment

Under authority of § 9.20 of Civil Service Rule IX (5 CFR 9.20), the Civil Service Commission revokes the authority of the Department of the Interior to fill by

noncareer executive assignment in the excepted service the position of Associate Director, Office of Water Resources Research, Office of the Secretary.

UNITED STATES CIVIL SERVICE COMMISSION,

[SEAL] JAMES C. SPRY,
Executive Assistant to
the Commissioners.

[FR Doc.71-16580 Filed 11-11-71;8:50 am]

DEPARTMENT OF TRANSPORTATION

Notice of Grant of Authority to Make Noncareer Executive Assignment

Under authority of § 9.20 of Civil Service Rule IX (5 CFR 9.20), the Civil Service Commission authorizes the Department of Transportation to fill by noncareer executive assignment in the excepted service the position of Director, Office of Congressional Relations, Office of the Secretary.

UNITED STATES CIVIL SERVICE COMMISSION,

[SEAL] JAMES C. SPRY,
Executive Assistant
to the Commissioners.

[FR Doc.71-16580 Filed 11-11-71;8:50 am]

ENVIRONMENTAL PROTECTION AGENCY

2-ETHYLAMINO-4-ISOPROPYLAMINO-6-METHYLTHIO-S-TRIAZINE

Notice of Establishment of Temporary Tolerance

Geigy Agricultural Chemicals, Division of Ciba-Geigy Corp., Ardsley, N.Y. 10502, submitted a petition requesting a temporary tolerance for residues of the herbicide 2-ethylamino-4-isopropylamino-6-methylthio-s-triazine in or on the raw agricultural commodities citrus fruits at 0.25 part per million.

It has been determined that a temporary tolerance of 0.25 part per million for residues of the herbicide in or on citrus fruits is safe and will protect the public health. It is therefore established on condition that the herbicide be used in accordance with the temporary permit being issued concurrently by the Environmental Protection Agency and which provides for distribution under the Geigy Agricultural Chemicals Corp. name.

This temporary tolerances expires November 4, 1972.

This action is taken pursuant to provisions of the Federal Food, Drug, and Cosmetic Act (sec. 408(j), 68 Stat. 516; 21 U.S.C. 346a(j)), the authority transferred to the Administrator (35 F.R. 15623), and the authority delegated by

the Administrator to the Deputy Assistant Administrator for Pesticides Programs of the Environmental Protection Agency (36 F.R. 9038).

Dated: November 4, 1971.

WILLIAM M. UPHOLT,
Deputy Assistant Administrator
for Pesticides Programs.

[FR Doc.71-16533 Filed 11-11-71;8:46 am]

NACA INDUSTRY TASK FORCE

Notice of Amended Filing of Petition Regarding Pesticide Chemical

Notice was given in the FEDERAL REGISTER of June 4, 1971 (36 F.R. 10900), that a petition (PP 1F1102) had been filed by the National Agricultural Chemicals Association's Industry Task Force on Phenoxy Herbicide Tolerances, 1155 15th Street NW., Washington, DC 20005, proposing establishment of tolerances for residues of the herbicide 2,4,5-T (2,4,5-trichlorophenoxyacetic acid) in or on the raw agricultural commodities grass at 300 parts per million and apples, barley, blueberries, corn, oats, rice, rye, sugarcane, and wheat at 0.2 part per million (negligible residue) from application of the herbicide in either the acid form or in the form of one or more of the following salts or esters:

1. The amine salts: Alkyl (C-12), alkyl (C-13), alkyl (C-14), *N,N*-dimethyloleamine, *N,N*-dimethylinoleamine, *N*-oleyl-1,3-propylenediamine, triethanolamine, and triethylamine.

2. The esters: Alkyl (C₈H₁₇-C₈H₁₇), amyl, butyl, butoxyethyl, butoxypropyl, dipropylene glycol isobutyl ether, 2-ethylhexyl (isooctyl), propylene glycol butyl ether, propylene glycol isobutyl ether, and tripropylene glycol isobutyl ether.

Pursuant to provisions of the Federal Food, Drug, and Cosmetic Act (sec. 408(d)(1), 409(b)(5), 68 Stat. 512, 72 Stat. 1786; 21 U.S.C. 346a(d)(1), 348(b)(5)), notice is given that said petition has been amended by:

a. Withdrawing the request for tolerances regarding barley, corn, oats, rye, and wheat.

b. Adding the commodities rice straw at 1 part per million; meat and meat byproducts of cattle, goats, and sheep at 0.1 part per million (negligible residue); and milk at 0.05 part per million (negligible residue).

c. Reducing the proposed 0.2 part per million tolerance on apples, blueberries, rice, and sugarcane to 0.1 part per million (negligible residue).

Notice is also given that the same association has filed a related food additive petition (FAP 2H2670), proposing establishment of a food additive tolerance (21 CFR Part 121) of 0.5 part per million for residues of the herbicide in or on sugarcane bagasse resulting from

application of the herbicide to sugarcane fields.

Dated: November 4, 1971.

WILLIAM M. UPHOLT,
Deputy Assistant Administrator
for Pesticides Programs.

[FR Doc.71-16568 Filed 11-11-71;8:49 am]

FEDERAL RESERVE SYSTEM

[Reg. Y]

BANK HOLDING COMPANIES

Notice of Hearing Regarding Rhode Island Thrift Institutions Investments in Commercial Banks

Newport Savings and Loan Association, Newport, R.I., has applied for the Board's approval to become a registered bank holding company through acquisition of voting shares of the Island Trust Co., Newport, a proposed new bank.

Old Colony Cooperative Bank, Providence, R.I., has applied for the Board's approval to become a registered bank holding company through retention of voting shares of the Newport National Bank, Newport.

The Rhode Island legislature, in 1970, specifically authorized such associations to establish a bank or trust company or to purchase and hold a majority of the issued and outstanding stock of a bank or trust company. In the 1970 Amendments to the Bank Holding Company Act, Congress took special note of a situation similar to that contemplated by the proposals. Section 2(a)(5)(F) of the Act generally exempts from the purview of the Act federally insured mutual savings banks that directly or indirectly own one bank, if such ownership or control existed on the date of enactment of the 1970 Amendments and is specifically authorized by applicable State law. Each mutual savings bank in Rhode Island owns a commercial bank subsidiary.

Notice of receipt of the Newport application was published in the FEDERAL REGISTER on June 19, 1971 (36 F.R. 11832). Notice of receipt of the Old Colony application is published simultaneously with this document. In response to the Newport notice, the Board received several letters of comment objecting to approval of Newport's application.

In view of the substantial interest in the similar issues presented by the two applications, the Board has decided to conduct a hearing on the applications before available members of the Board in the Board Room of its building at 20th Street and Constitution Avenue, Washington, DC, on November 29, 1971, beginning at 10 a.m. Interested persons are invited to participate, but they need not participate by presenting material orally at the hearing to have their views

considered. All views expressed in written comments on the matter that are received before December 15, 1971, will be given consideration. Such material will be made available for inspection and copying upon request, except as provided in § 261.6(a) of the Board's rules regarding availability of information.

Following the hearing the Board expects to issue an order on each application. The orders will resolve the question of the parent company engaging in the activities of a thrift institution while at the same time engaging in commercial banking activities through a subsidiary.

This hearing is not designed to consider the general question whether operating a thrift institution is an activity that is "so closely related to banking or managing or controlling banks as to be a proper incident thereto" within the meaning of section 4(c)(8) of the Bank Holding Company Act. So far as the hearing concerns the relationship of a thrift institution to a bank holding company, the issue is limited to the type of structural and competitive circumstances existing in Rhode Island.

Persons interested in participating in the hearing by presenting material orally should inform the Secretary of the Board in writing not later than November 18, 1971. Each person admitted as a party to the proceeding will be given up to 30 minutes to present his views.

By order of the Board of Governors, November 4, 1971.

[SEAL]

TYNAN SMITH,
Secretary of the Board.

[FR Doc.71-16561 Filed 11-11-71; 8:49 am]

FIRST VIRGINIA BANKSHARES CORP.

Order Approving Acquisition of Bank Stock By Bank Holding Company

In the matter of the application of First Virginia Bankshares Corp., Arlington, Va., for approval of acquisition of 100 percent of the voting shares (less directors' qualifying shares) of the First Commercial Bank, Orange, Va., a proposed new bank.

There has come before the Board of Governors, pursuant to section 3(a)(3) of the Bank Holding Company Act of 1956 (12 U.S.C. 1842(a)(3)) and § 222.3(a) of Federal Reserve Regulation Y (12 CFR 222.3(a)), an application by First Virginia Bankshares Corp., Arlington, Va., a registered bank holding company, for the Board's prior approval of the acquisition of 100 percent of the voting shares (less directors' qualifying shares) of First Commercial Bank, Orange, Va. ("Bank"), a proposed new bank.

As required by section 3(b) of the Act, the Board gave written notice of receipt of the application to the Virginia Commissioner of Banking, and requested his views and recommendation. The Commissioner recommended approval.

Notice of receipt of the application was published in the FEDERAL REGISTER on September 8, 1971 (36 F.R. 18036),

providing an opportunity for interested persons to submit comments and views with respect to the proposal. A copy of the application was forwarded to the U.S. Department of Justice for its consideration. Time for filing comments and views has expired and all those received have been considered.

The Board has considered the application in the light of the factors set forth in section 3(c) of the Act, including the effect of the proposed acquisition on competition, the financial and managerial resources and future prospects of the applicant and the banks concerned, and the convenience and needs of the communities to be served, and finds that:

Applicant presently controls 16 banks with aggregate deposits of approximately \$478.5 million, representing 6 percent of the total commercial bank deposits in the State, and is the sixth largest banking organization in Virginia. (All banking data are as of December 31, 1970, and reflect holding company formations and acquisitions approved through September 30, 1971.) Since Bank is a proposed new bank, no existing competition would be eliminated nor would concentration be increased in any relevant area.

Bank will be located in the town of Orange, the county seat of Orange County. The largest and 12 largest banks in the State have six offices in Orange County and control virtually all area deposits. Applicant's closest subsidiary to Bank is located 30 miles southwest, on the outskirts of Charlottesville in Albemarle County. It appears that none of applicant's subsidiary banks derives a significant amount of banking business from the area to be served by Bank. Consummation of the proposal would represent the entry of a third large banking organization in the area, and should stimulate competition without having an undue adverse effect on other banks in the market.

The financial and managerial resources of applicant and its subsidiary banks are generally satisfactory and the prospects for the group appear favorable. Bank has no operating financial history. It will open with satisfactory capital, and it will be able to draw on applicant for its management. Its prospects are favorable. The banking factors are consistent with approval. Although there is no evidence that existing needs of the area are not being served adequately, the proposed location of Bank, one block from the heart of Orange's business district, is expected to serve the convenience of the area businesses and residents. Further, the establishment of Bank would provide an additional banking alternative to residents of the Orange area. Thus, considerations relating to convenience and needs of the community lend some weight in favor of approval of the application. It is the Board's judgment that consummation of the proposed acquisition would be in the public interest and that the application should be approved.

It is hereby ordered, On the basis of the record, that said application be and hereby is approved for the reasons summarized above, provided that the action

so approved shall not be consummated (a) before the 30th calendar day following the date of this order or (b) later than 3 months after the date of this order; and provided further that (c) First Commercial Bank shall be opened for business not later than 6 months after the date of this order. Each of the periods described in (b) and (c) hereof may be extended for good cause by the Board, or by the Federal Reserve Bank of Richmond pursuant to delegated authority.

By order of the Board of Governors,¹ November 4, 1971.

[SEAL]

TYNAN SMITH,
Secretary of the Board.

[FR Doc.71-16595 Filed 11-11-71; 8:47 am]

FIRST VIRGINIA BANKSHARES CORP.

Order Approving Acquisition of Bank Stock by Bank Holding Company

In the matter of the application of First Virginia Bankshares Corp., Arlington, Va., for approval of acquisition of 100 percent of the voting shares of the successor by merger to The Bank of Westmoreland, Colonial Beach, Va.

There has come before the Board of Governors, pursuant to section 3(a)(3) of the Bank Holding Company Act of 1956 (12 U.S.C. 1842(a)(3)) and § 222.3(a) of Federal Reserve Regulation Y (12 CFR 222.3(a)), an application by First Virginia Bankshares Corp., Arlington, Va., a registered bank holding company, for the Board's prior approval of the acquisition of 100 percent of the voting shares of the successor by merger to The Bank of Westmoreland, Colonial Beach, Va. ("Bank"). The bank into which Bank is to be merged has no significance except as a means of acquiring all of the shares of Bank. Accordingly, the proposed acquisition of the shares of the successor organization is treated herein as the proposed acquisition of the shares of Bank.

As required by section 3(b) of the Act, the Board gave written notice of receipt of the application to the Virginia Commissioner of Banking, and requested his views and recommendation. The Commissioner recommended approval.

Notice of receipt of the application was published in the FEDERAL REGISTER on September 8, 1971 (36 F.R. 18035), providing an opportunity for interested persons to submit comments and views with respect to the proposal. A copy of the application was forwarded to the U.S. Department of Justice for its consideration. Time for filing comments and views has expired and all those received have been considered.

The Board has considered the application in the light of the factors set forth in section 3(c) of the Act, including the effect of the proposed acquisition on competition, the financial and managerial resources and future prospects of

¹ Voting for this action: Governors Mitchell, Danne, Malsel, Brimmer, and Sherrill. Absent and not voting: Chairman Burns and Governor Robertson.

the applicant and the banks concerned, and the convenience and needs of the communities to be served, and finds that:

Applicant, the sixth largest banking organization in Virginia, controls 16 banks with deposits of \$478.5 million, representing 6.0 percent of total commercial bank deposits in the State. (All banking data are as of December 31, 1970, and reflect holding company formations and acquisitions approved through September 30, 1971.) The acquisition of Bank (\$21.5 million deposits), would increase applicant's share of deposits in the State by only 0.3 percentage points, representing no significant increase in applicant's control of deposits in the State, or change in its present ranking.

Bank, with five offices, is the largest of five organizations operating in its service area, which is approximated by King George, Westmoreland, and Northumberland Counties, where it holds 47.4 percent of area deposits. Bank does not appear to exert a dominant competitive influence in the area, and its share of area deposits has actually declined slightly in recent years. Due to the distances separating each of Bank's offices within this three-county area, Bank's head office and each branch have developed distinct service areas of their own. The closest office of any of applicant's subsidiary banks is located 35 miles from the King George Branch of Bank. No present competition exists between Bank and this office, or any of applicant's other offices. It also appears unlikely that consummation of this proposal would preclude potential competition because of Virginia's restrictive branching laws, the wide separation between applicant's offices and Bank, and the low population-to-bank ratio in Bank's service area. Based on the foregoing, and the record before it, the Board concludes that consummation of the proposed acquisition would not have an adverse effect on competition in any relevant market.

The banking factors, as they relate to applicant, its subsidiaries, and Bank are satisfactory and consistent with approval of the application. Considerations relating to the convenience and needs of the area lend some weight toward approval. The major banking needs of the area are being served at the present time; however, as a result of its affiliation with applicant, Bank would be able to offer expanded and improved services, including auditing, trust and data processing services, and greater mortgage lending capability. It is the Board's judgment that the proposed transaction is in the public interest and should be approved.

It is hereby ordered, On the basis of the record, that said application be and hereby is approved for the reasons summarized above, provided that the action so approved shall not be consummated (a) before the 30th calendar day following the date of this order or (b) later than 3 months after the date of this order, unless such period is extended for

good cause by the Board, or by the Federal Reserve Bank of Richmond pursuant to delegated authority.

By order of the Board of Governors,¹
November 4, 1971.

[SEAL]

TYNAN SMITH,
Secretary of the Board.

[FR Doc.71-16536 Filed 11-11-71;8:47 am]

OLD COLONY CO-OPERATIVE BANK

Notice of Applications for Approval to Become a Registered Bank Holding Company Through the Retention of Shares of Bank and to Continue to Engage in the Activities of a Thrift Institution

Notice is hereby given that applications have been made, pursuant to section 3(a)(1) and section 4(c)(8) of the Bank Holding Company Act of 1956 (12 U.S.C. 1842(a)(1) and 12 U.S.C. 1843(a)(8)), by Old Colony Co-operative Bank, Providence, R.I., for approval by the Board of Governors to become a registered bank holding company through the retention of voting shares of The Newport National Bank, Newport, R.I., and to continue thereafter to engage in the activities of a thrift institution.

Notice of the Board's decision to conduct a hearing in connection with these applications is published simultaneously with this document. Not later than December 15, 1971, written comments and views regarding the applications may be filed with the Board. Communications should be addressed to the Secretary, Board of Governors of the Federal Reserve System, Washington, D.C. 20551. The applications may be inspected at the office of the Board of Governors or the Federal Reserve Bank of Boston.

Board of Governors of the Federal Reserve System, November 8, 1971.

[SEAL]

TYNAN SMITH,
Secretary of the Board.

[FR Doc.71-16560 Filed 11-11-71;8:49am]

SECURITIES AND EXCHANGE COMMISSION

[70-5112]

ALABAMA POWER CO.

Notice of Proposed Issue and Sale of First Mortgage Bonds and Preferred Stock at Competitive Bidding

NOVEMBER 8, 1971.

Notice is hereby given that Alabama Power Co. (Alabama), 600 North 18th Street, Birmingham, AL 35202, an electric utility subsidiary company of The

¹ Voting for this action: Governors Mitchell, Daane, Maisel, Brimmer, and Sherrill. Absent and not voting: Chairman Burns and Governor Robertson.

Southern Co., a registered holding company, has filed an application with this Commission pursuant to the Public Utility Holding Company Act of 1935 (Act), designating section 6(b) of the Act and Rule 50 promulgated thereunder as applicable to the following proposed transactions. All interested persons are referred to the application, which is summarized below, for a complete statement of the proposed transactions.

Alabama proposes to issue and sell, subject to the competitive bidding requirements of Rule 50 under the Act, \$25,500,000 principal amount of its First Mortgage Bonds, ----- percent Series, to mature not less than 5 years and not more than 30 years from the second day of the calendar month within which the bonds are issued. Alabama will decide on the maturity of the bonds and notify prospective bidders not less than 72 hours prior to the time of the bidding. The interest rate (which shall be a multiple of one-eighth percent) and the price, exclusive of accrued interest, to be paid to Alabama (which shall be not less than 99 percent nor more than 102 percent of the principal amount thereof) will be determined by the competitive bidding. The bonds will be issued under an Indenture, dated as of January 1, 1942, between Alabama and Chemical Bank, as Trustee, as heretofore supplemented and as to be further supplemented by a Supplemental Indenture to be dated as of January 1, 1972, which includes a prohibition until January 1, 1977, against refunding the bonds with the proceeds of funds borrowed at a lower effective interest cost.

Alabama also proposes to issue and sell, subject to the competitive bidding requirements of Rule 50 under the Act, 380,000 shares of its ----- percent Cumulative Preferred Stock, par value \$100 per share. The dividend rate of the preferred stock (which shall be a multiple of 0.04 percent), and the price, exclusive of accrued dividends, to be paid to Alabama (which shall be not less than \$100 nor more than \$102 per share) will be determined by the competitive bidding. The terms of the preferred stock include a prohibition until January 1, 1977, against refunding the stock, directly or indirectly, with funds obtained from the issuance of debt securities at a lower effective interest cost or of preferred stock at a lower effective dividend cost. The proceeds from the sales of the bonds and preferred stock will be applied to the repayment of \$63,715,000 principal amount of First Mortgage Bonds, 3½ percent Series, which mature on January 1, 1972.

It is stated that the Alabama Public Service Commission has jurisdiction over the proposed issuance and sale of the bonds and preferred stock by Alabama and that no other State commission and no Federal commission, other than this Commission, has jurisdiction over the proposed transactions. The fees and expenses to be incurred in connection with the transactions will be supplied by amendment.

Notice is further given that any interested person may, not later than December 1, 1971, request in writing that a hearing be held on such matter, stating the nature of his interest, the reasons for such request, and the issues of fact or law raised by said application which he desires to controvert; or he may request that he be notified if the Commission should order a hearing thereon. Any such request should be addressed: Secretary, Securities and Exchange Commission, Washington, D.C. 20549. A copy of such request should be served personally or by mail (airmail if the person being served is located more than 500 miles from the point of mailing) upon the applicant at the above-stated address, and proof of service (by affidavit or, in case of an attorney at law, by certificate) should be filed with the request. At any time after said date, the application, as filed or as it may be amended, may be granted as provided in Rule 23 of the general rules and regulations promulgated under the Act, or the Commission may grant exemption from such rules as provided in Rules 20(a) and 100 thereof or take such other action as it may deem appropriate. Persons who request a hearing or advice as to whether a hearing is ordered will receive notice of further developments in this matter, including the date of the hearing (if ordered) and any postponements thereof.

For the Commission, by the Division of Corporate Regulation, pursuant to delegated authority.

[SEAL] RONALD F. HUNT,
Secretary.

[FR Doc. 71-16542 Filed 11-11-71; 8:47]

[812-3031]

BUTCHER & SHERRERD

Notice of Filing of Application for Exemption

NOVEMBER 8, 1971.

Notice is hereby given that Butcher and Sherrerd (Applicant), 1500 Walnut Street, Philadelphia, PA 19102, a Pennsylvania limited partnership and a prospective representative, with Thomson & McKinnon Auchincloss, Inc., of a group of underwriters to be formed in connection with a proposed public offering of shares of Federated Income and Private Placement Fund (Fund), a registered closed-end investment company has filed an application pursuant to section 6(c) of the Investment Company Act of 1940 (Act) for an order exempting Applicant and its co-underwriters from the provisions of section 30(f) of the Act to the extent that section adopts section 16(b) of the Securities Exchange Act of 1934 (Exchange Act) with respect to their transactions incidental to the distribution of Fund shares.

All interested persons are referred to the application on file with the Commission for a statement of the representations contained therein, which are summarized below.

Shares of the Fund are to be purchased by the underwriters pursuant to an Underwriting Agreement to be entered into between the representatives of the underwriters, Fund, Income Research Corp., the Fund's investment adviser, and Federated Research Corp., the Fund's subadviser.

It is also contemplated that one or more dealers will offer and sell certain of the shares and will enter into Selected Dealer Agreements in connection therewith. It is intended that the several underwriters will make a public offering of all the Fund shares which such underwriters are to purchase under the Underwriting Agreement at the price therein specified, as soon on or after the effective date of the Fund's Registration Statement under the Securities Act of 1933 as the Applicant deems advisable, and such shares are initially to be offered to the public in accordance with the formula for the determination of the per share public offering price and underwriting commissions to be specified in the Underwriting Agreement, and the formulae for determination of dealer concessions to be specified in the Selected Dealer Agreements, at the time the Registration Statement becomes effective under the Securities Act of 1933. Although 2,100,000 shares have been included in the Registration Statement, the actual number of shares which may be the subject of the proposed public offering may be increased or decreased by the Applicant and the Fund shortly before the proposed public offering, and depending upon the exercise of an overallotment option granted to the underwriters.

Section 30(f) of the Act, in pertinent part, provides that every person who is directly or indirectly the beneficial owner of more than 10 per centum of any class of outstanding securities of which a registered closed-end company shall in respect of his transactions in the securities of such company be subject to the same duties and liabilities as those imposed by section 16 of the Exchange Act upon certain beneficial owners in respect of transactions in certain equity securities. Section 16(b) provides, in pertinent part, that for the purpose of preventing the unfair use of information which may have been obtained by such beneficial owner by reason of his relationship to the issuer, any profit realized by him from any purchase and sale, or sale and purchase, of any equity security of such issuer within any period of less than 6 months shall inure to and be recoverable by the issuer.

Rule 16b-2 under the Exchange Act exempts certain transactions in connection with a distribution of securities from the operation of section 16(b) thereof. One such requirement, stated in Rule 16b-2(a)(3), is that the aggregate participation of persons not within the purview of section 16(b) of the Exchange Act be at least equal to the aggregate participation of all persons exempted from the provisions of section 16(b) by Rule 16b-2.

Although it is anticipated that the requirements of paragraphs (a)(1) and (a)(2) of Rule 16b-2 will be met it is possible that the condition in paragraph (a)(3) described above, will not be met in that one or more underwriters, even though they are obligated through the Underwriting Agreement to purchase 10 percent or less of the aggregate number of shares of the Company's Common Stock to be outstanding upon completion of the initial public offering of the shares, may, as a consequence of defaults by other underwriters who do not purchase their respective Underwriting Commitments, become obligated to purchase on the Closing Date more than 10 percent of the aggregate number of shares of the Company's Common Stock to be outstanding after the closing and that one or more of the Underwriters becoming so obligated may, as underwriters and as Selected Dealers, distribute more than 50 percent of the aggregate number of shares being offered.

In addition to purchases from the Fund and sales to customers, there may be the usual transactions of purchase or sale incidental to a distribution such as stabilizing purchases, purchases to cover overallocations or other short positions created in connection with such distribution, and sales of shares purchased in stabilization.

Applicant states there is no inside information in existence since the Fund, prior to the initial distribution of its shares, will have no assets (other than cash) or business of any sort, and all material information will be set forth in the prospectus. Therefore, the underwriters will not be privy to "inside information." Applicant states that the purpose of the purchase of the shares by the underwriters will be for resale in connection with the initial distribution of the shares, and submits that those purchases and sales will therefore be transactions effected in connection with a distribution of a substantial block of securities within the purpose and spirit of Rule 16b-2.

Applicant requests an order exempting the proposed transactions in the securities of the Fund, as described in the application, from the provisions of section 30(f) of the Act on the ground that such exemption is necessary and appropriate in the public interest and consistent with the protection of investors and the purposes fairly intended by the policy and provisions of the Act. Applicant further contends that the transactions sought to be exempted cannot lend themselves to the practices which section 16(b) of the Exchange Act and section 30(f) of the Act is intended to prevent.

Section 6(c) authorizes the Commission to exempt any person, security or transaction, or any class or classes of persons, securities, or transaction, or any class or classes of persons, securities, or transactions, from the provisions of the Act and Rules promulgated thereunder if and to the extent that such exemption is necessary or appropriate in the public

interest and consistent with the protection of investors and the purposes fairly intended by the policy and provisions of the Act.

Notice is further given that any interested person may, not later than November 25, 1971 at 5:30 p.m., submit to the Commission in writing a request for a hearing on the matter accompanied by a statement as to the nature of his interest, the reason for such request and the issues of fact or law proposed to be controverted, or he may request that he be notified if the Commission shall order a hearing thereon. Any such communication should be addressed: Secretary, Securities and Exchange Commission, Washington, D.C. 20549. A copy of such request shall be served personally or by mail (airmail if the person being served is located more than 500 miles from the point of mailing) upon Applicant at the address stated above. Proof of such service (by affidavit or in case of an attorney at law by certificate) shall be filed contemporaneously with the request. At any time after said date, as provided by Rule 0-5 of the rules and regulations promulgated under the Act, an order disposing of the application herein may be issued by the Commission upon the basis of the information stated in said application, unless an order for hearing thereon shall be issued upon request or upon the Commission's own motion. Persons who request a hearing or advice as to whether a hearing is ordered will receive notice of further developments in this matter, including the date of the hearing, (if ordered) and any postponements thereof.

For the Commission, by the Division of Corporate Regulation, pursuant to delegated authority.

[SEAL] RONALD F. HUNT,
Secretary.
[FR Doc.71-16543 Filed 11-11-71;8:47 am]

[70-5111]

EAST OHIO GAS CO. ET AL.

Notice of Proposed Intrasystem Sale of Gas Pipe Line Assets to Affiliated Gas Utility Companies and Related Transactions

NOVEMBER 8, 1971.

Notice is hereby given that Consolidated Natural Gas Co. (Consolidated Natural), 30 Rockefeller Plaza, New York, NY 10020, a registered holding company, and three of its wholly owned subsidiary companies, the East Ohio Gas Co. (East Ohio), Lake Shore Pipe Line Co. (Lake Shore), and Consolidated Gas Supply Corp. (Supply Corporation), have filed an application-declaration with this Commission pursuant to the Public Utility Holding Company Act of 1935 (Act), designating sections 9(a), 10, 12(f), and 12(g) of the Act and Rules 43, 44, and 45 thereunder as applicable to the proposed transactions. All interested persons are referred to the application-declaration, which is summarized below, for a com-

plete statement of the proposed transactions.

Lake Shore is engaged in the business of purchasing, producing, gathering, transporting, and selling natural gas at wholesale to its sole customer, East Ohio. The principal facilities operated by Lake Shore consist of approximately 43.5 miles of a 10 $\frac{1}{4}$ -inch transmission pipeline located in Pennsylvania where it connects with facilities of Tennessee Gas Pipeline Co. and in Ohio where it connects with purchase facilities of East Ohio. All of the gas delivered to East Ohio through this transmission pipeline is for the account of Supply Corp.

An Agreement and Plan of Liquidation has been entered into by the above-named companies pursuant to which Lake Shore proposes to sell all of its operating properties and certain other assets to two affiliated companies, East Ohio and Gas Supply, in exchange for the assumption by them of Lake Shore's long-term debt to Consolidated Natural in amounts equal to the net book value of the assets of Lake Shore acquired by East Ohio and Supply Corp., respectively. Such debt to be assumed will amount to \$313,000 in the case of East Ohio and \$526,000 in the case of Supply Corp. All of Lake Shore's properties in Ohio are to be sold to East Ohio, which operates solely in Ohio, and all of its properties in Pennsylvania are to be sold to Supply Corp., which, among other things, operates a natural gas pipeline system in Pennsylvania. Following consummation of the proposed acquisitions, Lake Shore is to be dissolved. Supply Corp. will continue to make gas deliveries through the facilities presently belonging to Lake Shore, except that deliveries through the transmission pipeline will be at the Ohio-Pennsylvania border.

It is stated that the proposed sale of facilities constitutes the final step in the discontinuance of Lake Shore's operations in the simplification and realignment of the operating companies of the Consolidated System and is in accord with a commitment made to the Federal Power Commission in 1962.

The fees and expenses to be incurred in connection with the proposed transactions are estimated at \$12,750, including service company charges, at cost, of \$7,750.

The filing states that the Public Utilities Commission of Ohio has jurisdiction over the assumption by East Ohio of the long-term debt of Lake Shore, that the Federal Power Commission has jurisdiction over the abandonment of the facilities proposed to be sold by Lake Shore and over the acquisition of a substantial portion of such facilities by Supply Corp., and that no other State or Federal commission, other than this Commission, has jurisdiction over the proposed transactions.

Notice is further given that any interested person may, not later than November 29, 1971, request in writing that a hearing be held on such matter, stating the nature of his interest, the reasons for such request, and the issues of fact

or law raised by the filing which he desires to controvert; or he may request that he be notified if the Commission should order a hearing thereon. Any such request should be addressed: Secretary, Securities and Exchange Commission, Washington, D.C. 20549. A copy of such request should be served personally or by mail (airmail if the person being served is located more than 500 miles from the point of mailing) upon the applicants-declarants at the above-stated address, and proof of service (by affidavit or, in case of an attorney at law, by certificate) should be filed with the request. At any time after said date, the application-declaration, as filed or as it may be amended, may be granted and permitted to become effective as provided in Rule 23 of the general rules and regulations promulgated under the Act, or the Commission may grant exemption from such rules as provided in Rules 20(a) and 100 thereof or take such other action as it may deem appropriate. Persons who request a hearing or advice as to whether a hearing is ordered will receive notice of further developments in this matter, including the date of the hearing (if ordered) and any postponements thereof.

For the Commission, by the Division of Corporate Regulation, pursuant to delegated authority.

[SEAL] RONALD F. HUNT,
Secretary.
[FR Doc.71-16544 Filed 11-11-71;8:47 am]

[File No. 2-7749 (22-816); 2-26429 (22-4453)]

NEW BEDFORD GAS AND EDISON LIGHT CO. AND CAPE & VINEYARD ELECTRIC CO.

Notice of Application and Opportunity for Hearing

NOVEMBER 8, 1971.

Notice is hereby given that New Bedford Gas and Edison Light Co. (New Bedford) has filed an application under clause (h) of section 310(b)(1) of the Trust Indenture Act of 1939 (the "Act") for a finding that the trusteeship of State Street Bank and Trust Company of Boston, Mass. (State Street), under certain indentures of New Bedford and of Cape & Vineyard Electric Co. (Cape) is not so likely to involve a material conflict of interest as to make it necessary in the public interest or for the protection of investors to disqualify State Street from acting as trustee under any of such indentures.

Section 310(b) of the Act provides in part that if a trustee under an indenture qualified under the Act has or shall acquire any conflicting interest (as defined in the section), it shall within 90 days after ascertaining that it has such a conflicting interest, either eliminate such conflicting interest or resign. Subsection (1) of this section provides, with certain exceptions, that a trustee under a qualified indenture shall be deemed

to have a conflicting interest if such trustee is trustee under another indenture under which any other securities, or certificates of interest or participation in any other securities, of the same issuer are outstanding. However, under clause (ii) of section (1), there may be excluded from the operations of this provision another indenture or indentures under which other securities of the issuer are outstanding, if the issuer shall have sustained the burden of proving, on application to the Commission and after opportunity for hearing thereon, that trusteeship under a qualified indenture and another indenture is not so likely to involve a material conflict of interest as to make it necessary in the public interest or for the protection of investors to disqualify such trustee from acting as trustee under one of such indentures.

New Bedford alleges that:

(1) New Bedford has outstanding the following five series of notes, under indentures under which State Street is trustee:

(a) \$3,800,000 principal amount of its 3 percent notes, Series A, due November 1, 1973, which were issued under an indenture of trust dated November 1, 1948.

(b) \$2,952,000 principal amount of its 2½ percent notes, Series B, due October 1, 1975, which were issued under the first supplemental indenture to the New Bedford indenture.

(c) \$4,496,000 principal amount of its 4½ percent notes, Series C, due April 1, 1986, which were issued under the second supplemental indenture to the New Bedford indenture.

(d) \$9,500,000 principal amount of its 5½ percent notes, Series D, due April 1, 1992, which were issued under the fourth supplemental indenture to the New Bedford indenture.

(e) \$8,970,000 principal amount of its 8½ percent notes, Series E, due December 1, 1995, which were issued under the fifth supplemental indenture to the New Bedford indenture.

(2) Cape has outstanding the following two series of notes under indentures under which State Street is trustee:

(a) \$3,010,000 principal amount of its 4.90 percent notes, due April 1, 1987, which were issued under an indenture of trust date April 1, 1957.

(b) \$5,760,000 principal amount of its 6½ percent notes, Series B, due June 1, 1997, which were issued under the first supplemental indenture to the Cape indenture.

(3) Pursuant to an agreement of merger dated April 23, 1971, it is expected that on or about December 1, 1971, Cape will be merged into New Bedford in accordance with the requirements of the provisions of Chapter 164 of the General Laws of Massachusetts.

(4) The agreement of merger provides, among other things, that upon consummation of the merger, New Bedford will thenceforth be responsible for all debts, liabilities, and obligations of Cape.

(5) Thereupon, in accordance with the terms of both the New Bedford indenture and the Cape indenture, New Bedford will execute and deliver to State Street a supplemental indenture, pursuant to which New Bedford will assume the due and punctual payment of the principal of, premium, if any, and interest on the Series A notes and the Series B notes outstanding under the Cape indentures according to their terms, and the due and punctual performance and observance of all terms, covenants, and conditions of the Cape indenture to be kept or performed by Cape.

(6) The obligations under the New Bedford indenture and the obligations under the Cape indenture represent general obligations ranking pari passu one with another and without preference of one over the other of any kind.

(7) Both the New Bedford notes and the Cape are wholly unsecured.

(8) Aside from inherent differences between the New Bedford indenture and the Cape indenture as to amounts, dates, interest rates, and sinking fund established with respect to each series of notes, most of the provisions of said indentures, including the particular covenants of the respective issuers which apply to the future, are substantially identical.

(9) New Bedford is not in default under the New Bedford indenture, and Cape is not in default under the Cape indenture and the consummation of the merger will not constitute a default under either of said indentures.

(10) It is the opinion of New Bedford that the differences between the New Bedford and Cape indenture are not so likely to involve a material conflict of interest as to make it necessary in the public interest or for the protection of investors to disqualify State Street from acting as trustee under both of the indentures as supplemented.

(11) New Bedford waives notice of hearing, and any and all rights to specify procedures under the rules of practice of the Commission in connection with this matter.

For a more detailed statement of the matters of fact and law asserted, all persons are referred to such application which is on file in the offices of the Commission at 500 North Capitol Street, Washington, DC 20549.

Notice is further given that any interested person may, not later than November 28, 1971, request in writing that a hearing be held on such matter, stating the nature of his interest, the reasons for such request, and the issues of fact or law raised by said application which he desires to controvert; or he may request that he be notified if the Commission should order a hearing thereon. Any such request should be addressed: Secretary, Securities and Exchange Commission, Washington, D.C. 20549. At any time after said date, the Commission may issue an order granting the application, upon terms and conditions as the Commission may deem necessary or ap-

propriate in the public interest and the interest of investors, unless a hearing is ordered by the Commission.

For the Commission, by the Division of Corporation Finance (pursuant to delegated authority).

[SEAL]

RONALD F. HUNT,
Secretary.

[FR Doc.71-16545 Filed 11-11-71;8:48 am]

[70-5090]

OHIO POWER CO. AND CAPTINA OPERATING CO.

Notice of Proposed Issue and Sale of Common Stock by Subsidiary Company and Acquisition by Parent Utility Company

NOVEMBER 8, 1971.

Notice is hereby given that Ohio Power Co. (Ohio Power), 301 Cleveland Avenue SW., Canton, OH 44701, an electric utility subsidiary company of American Electric Power Co., Inc. (AEP), a registered holding company, and Captina Operating Company (Captina), Post Office Box K, Moundsville, WV 26041, a presently inactive wholly owned subsidiary company of Ohio Power, have filed an application and an amendment thereto with this Commission pursuant to the Public Utility Holding Company Act of 1935 (Act), designating sections 6(b), 9, and 10 of the Act as applicable to the proposed transactions. All interested persons are referred to the application, which is summarized below, for a complete statement of the proposed transactions.

Captina, a West Virginia corporation, organized in 1956 to, among other things, develop, mine, and sell coal and manage, operate, and maintain steam electric generating stations, has been inactive since December 31, 1966. Captina has 5,000 shares of common stock (par value \$1) authorized and 1,000 such shares outstanding and as of June 30, 1971, had total assets of \$1,681. Upon authorization of the transactions proposed herein, the name of Captina will be changed to Southern Ohio Coal Co. (Southern Ohio) and Southern Ohio will take the necessary steps to qualify to do business in the State of Ohio and develop and mine such coal reserves either owned by Ohio Power, or which Ohio Power may transfer to it.

Ohio Power has under construction three 1,300,000 kilowatt coal-fired steam electric generating units. In order to assure a reliable supply of coal for these generating facilities, a financing program for Southern Ohio is proposed to permit it to develop and mine various reserves of coal owned or controlled by Ohio Power in southern and eastern Ohio. Southern Ohio proposes to issue and sell, on or before July 1, 1973, 4,000 shares of its common stock, and Ohio Power proposes to acquire such stock for a consideration of \$2,500 per share (\$10 million).

Ohio Power's three 1,300,000 kilowatt units will require in aggregate over 10 million tons of coal per year. It is stated that the most significant coal reserve to be developed and mined by Southern Ohio is Ohio Power's Wellston Coal Field, which has an estimated 270 million tons of recoverable coal. In addition to the Wellston reserve, Southern Ohio will initially commence development and mining of certain other coal reserves, which have an estimated 137 million tons of recoverable coal. All of these coal reserves must be "deep mined." None of the coal to be mined by Southern Ohio will be sold to anyone other than public utility companies in the AEP system.

It is estimated that the development of such coal reserves will require capital expenditures of approximately \$20 million through 1973. Additional financing requirements will be the subject of future applications. The charges for coal by Southern Ohio will be based on an amount equal to the actual cost of Southern Ohio in developing the reserve and mining such coal, including all appropriate overheads and interest charges and including a reasonable rate of return on Ohio Power's equity investment in Southern Ohio. Such rate of return will be no greater than the return then being earned by Ohio Power on equity invested in electric plant as determined pursuant to the then effective Uniform System of Accounts prescribed by the Federal Power Commission for electric utility companies.

It is stated that no fees or commissions will be paid in connection with the proposed transactions with the exception of miscellaneous expenses estimated not to exceed \$500. It is further stated that no State commission and no Federal commission, other than this Commission, has jurisdiction over the proposed transactions.

Notice is further given that any interested person may, not later than November 30, 1971, request in writing that a hearing be held on such matter, stating the nature of his interest, the reasons for such request, and the issues of fact or law raised by said application which he desires to controvert; or he may request that he be notified if the Commission should order a hearing thereon. Any such request should be addressed: Secretary, Securities and Exchange Commission, Washington, D.C. 20549. A copy of such request should be served personally or by mail (airmail if the person being served is located more than 500 miles from the point of mailing) upon the applicants at the above-stated addresses, and proof of service (by affidavit or, in case of an attorney at law, by certificate) should be filed with the request. At any time after said date, the application as amended or as it may be further amended, may be granted as provided in Rule 23 of the general rules and regulations promulgated under the Act, or the Commission may grant exemption from such rules as provided in Rules 20(a) and 100 thereof or take such other action as it may

deem appropriate. Persons who request a hearing or advice as to whether a hearing is ordered will receive notice of further developments in this matter, including the date of the hearing (if ordered) and any postponements thereof.

For the Commission, by the Division of Corporate Regulations, pursuant to delegated authority.

[SEAL] RONALD F. HUNT,
Secretary.

[FR Doc.71-16546 Filed 11-11-71;8:48 am]

[811-1707]

PROFESSIONAL RETIREMENT EQUITY FUND, INC.

Notice of Filing of Application Declaring That Company Has Ceased To Be an Investment Company

NOVEMBER 8, 1971.

Notice is hereby given that an application has been filed pursuant to section 8(f) of the Investment Company Act of 1940 (Act) for an order of the Commission declaring that Professional Retirement Equity Fund, Inc. (Applicant), 245 Park Avenue, New York, NY 10017, has ceased to be an investment company as defined in the Act. All interested persons are referred to the application on file with the Commission for a statement of the representations contained therein which are summarized below.

Applicant was organized on April 10, 1968, under the laws of the State of Delaware, and registered under the Act on August 8, 1968. The application represents that Applicant presently has no shareholders. It has not made nor does it propose to make a public offering of its securities. Applicant has no assets of any kind.

The application further represents that Applicant has not engaged in any business activity and does not propose at any time in the future to engage in any business including the business of investing, reinvesting, holding or trading in securities.

Section 3(c)(1) of the Act excepts from the definition of investment company any issuer whose outstanding securities are beneficially owned by not more than 100 persons and which is not making and does not presently propose to make a public offering of its securities.

Section 8(f) of the Act provides, in pertinent part, that when the Commission, upon application, finds that a registered investment company has ceased to be an investment company, it shall so declare by order, and upon the taking effect of such order, the registration of such company shall cease to be in effect, and that, if necessary for the protection of investors, such order may be made upon appropriate conditions.

Notice is further given that any interested person may, not later than November 30, 1971, submit to the Commission in writing a request for hearing on the matter accompanied by a statement

as to the nature of his interest, the reason for such request and the issues, if any, of fact or law proposed to be controverted, or he may request that he be notified if the Commission should order a hearing thereon. Any such communication should be addressed: Secretary, Securities and Exchange Commission, Washington, D.C. 20549. A copy of such request shall be served personally or by mail (airmail if the person being served is located more than 500 miles from the point of mailing) upon Applicant at the address stated above. Proof of such service (by affidavit or in case of an attorney-at-law by certificate) shall be filed contemporaneously with the request. At any time after said date as provided by Rule 0-5 of the rules and regulations promulgated under the Act, an order disposing of the application herein may be issued by the Commission upon the basis of the information stated in said application, unless an order for hearing upon said application shall be issued upon request or upon the Commission's own motion. Persons who request. At any time after said date as proposed a hearing is ordered will receive notice of further developments in this matter, including the date of the hearing (if ordered) and any postponements thereof.

For the Commission, by the Division of Corporate Regulation, pursuant to delegated authority.

[SEAL] RONALD F. HUNT,
Secretary.

[FR Doc.71-16547 Filed 11-11-71;8:48 am]

[File No. 1-6906]

ROYAL ATLAS CORP.

Notice of Application To Withdraw from Listing and Registration

NOVEMBER 5, 1971.

The above named issuer (Common Stock—\$1 par value) has filed an application with the Securities and Exchange Commission pursuant to section 12(d) of the Securities Exchange Act of 1934 and Rule 12d2-2(d) promulgated thereunder, to withdraw the specified security from listing and registration on the National Stock Exchange.

The reasons alleged in the application for withdrawing this security from listing and registration include the following:

The board of directors has determined that the interests of the company's shareholders can best be served by joining the NASDAQ quotation system. In a letter dated October 27, 1971, which is on file with the delisting application, the exchange disagrees with the company's reasons, and opposes the delisting application.

Any interested person may, on or before November 22, 1971, submit by letter to the Secretary of the Securities and Exchange Commission, Washington, D.C. 20549, facts bearing upon whether the application has been made in accordance with the rules of the exchange

and what terms, if any, should be imposed by the Commission for the protection of investors. An order granting the application will be issued after the date mentioned above, on the basis of the application and any other information furnished to the Commission, unless it orders a hearing on the matter.

For the Commission (pursuant to delegated authority).

[SEAL] RONALD F. HUNT,
Secretary.

[FR Doc.71-16548 Filed 11-11-71;8:48 am]

[File No. 24D-3011]

SYDNOR-BARENT SCANNER CORP.

Order Temporarily Suspending Exemption, Statement of Reasons, and Notice of Opportunity for Hearing

NOVEMBER 2, 1971.

Sydnor-Barent Scanner Corp. (issuer), 5404 Coal, Southeast, Albuquerque, NM, a New Mexico corporation with offices located at Albuquerque, N. Mex., filed with this Commission, on August 26, 1970, a notification on a Form 1-A and an offering circular relating to an offering of 200,000 shares of capital stock at \$1.50 per share for an aggregate of \$300,000 for the purpose of obtaining an exemption from the registration requirements of the Securities Act of 1933, as amended, pursuant to the provisions of section 3(b) thereof, and Regulation A adopted thereunder. Doherty & Co., 209 Gold Avenue, Albuquerque, NM, was designated as underwriter for the issuer and would receive a 10 percent commission. The offering commenced on October 29, 1970.

Based on information reported by the staff, the Commission has reason to believe:

A. The offering circular contains untrue statements of material facts and omits to state material facts necessary to make the statements made, in the light of the circumstances under which they were made, not misleading, particularly with respect to:

1. Representations to the effect that the Flying Spot Scanner (Scanner) was to be the issuer's principal product and that the bulk of the proceeds of the offering were to be used to manufacture and market the Scanner.

2. The failure to disclose that a substantial amount of the proceeds of the offering were to be allocated to affiliated companies and persons.

3. The failure to disclose that the initial sales offers of the issuer were not successful.

B. The terms and conditions of Regulation A were not complied with, in that:

1. The issuer failed to describe accurately and adequately the issuer's business and proposed business as required by Schedule I.

2. The issuer failed to set forth accurately and adequately the use to which proceeds of the offering would be allocated as required by Schedule I.

C. The offering was made in violation of section 17(a) of the Securities Act

of 1933, as amended, by reason of the activities described above.

D. The issuer, its officers, directors, underwriter, and attorneys failed to cooperate with the staff of the Commission in that they acquiesced in the filing of false and misleading information with the Commission subsequent to requests for information made by the staff.

It appearing to the Commission that it is in the public interest and for the protection of investors that the exemption of the issuer under Regulation A be temporarily suspended.

It is ordered, Pursuant to Rule 261(a) of the general rules and regulations under the Securities Act of 1933, as amended, that the exemption of the issuer under Regulation A be, and it hereby is, temporarily suspended.

It is further ordered, Pursuant to Rule 7 of the Commission's rules of practice, that the issuer file an answer to the allegations contained in this order within 30 days of the entry hereof.

Notice is hereby given that any person having any interest in the matter may file with the Secretary of the Commission a written request for hearing within 30 days after the entry of this order; that within 20 days after receipt of such request, the Commission will, or at any time upon its own motion may, set the matter down for hearing at a place to be designated by the Commission for the purpose of determining whether this order of suspension should be vacated or made permanent, without prejudice, however, to the consideration and presentation of additional matters at the hearing; and that notice of the time and place for said hearing will be promptly given by the Commission. If no hearing is requested and none is ordered by the Commission, the order shall become permanent on the 30th day after its entry and shall remain in effect unless it is modified or vacated by the Commission.

By the Commission.

[SEAL] RONALD F. HUNT,
Secretary.

[FR Doc.71-16550 Filed 11-11-71;8:48 am]

TARIFF COMMISSION

[AA1921-83]

ICE CREAM SANDWICH WAFERS FROM CANADA

Notice of Investigation and Hearing

Having received advice from the Treasury Department on November 1, 1971, that ice cream sandwich wafers from Canada are being, or are likely to be, sold in the United States at less than fair value, the U.S. Tariff Commission has instituted an investigation under section 201(a) of the Antidumping Act, 1921, as amended (19 U.S.C. 160(a)), to determine whether an industry in the United States is being or is likely to be injured, or is prevented from being established, by reason of the importation of such merchandise into the United States.

Hearing. A public hearing in connection with the investigation will be held

in the Tariff Commission's Hearing Room, Tariff Commission Building, 8th and E Streets NW., Washington, DC, beginning at 10 a.m., e.s.t., on December 7, 1971. All parties will be given opportunity to be present, to produce evidence, and to be heard at such hearing. Interested parties desiring to appear at the public hearing should notify the Secretary of the Tariff Commission, in writing, at its offices in Washington, D.C., at least 5 days in advance of the date set for the hearing.

Issued: November 8, 1971.

By order of the Commission.

[SEAL] KENNETH R. MASON,
Secretary.

[FR Doc.71-16551 Filed 11-11-71;8:48 am]

INTERSTATE COMMERCE COMMISSION

ASSIGNMENT OF HEARINGS

NOVEMBER 9, 1971.

Cases assigned for hearing, postponement, cancellation, or oral argument appear below and will be published only once. This list contains prospective assignments only and does not include cases previously assigned hearing dates. The hearings will be on the issues as presently reflected in the official docket of the Commission. An attempt will be made to publish notices of cancellation of hearings as promptly as possible, but interested parties should take appropriate steps to insure that they are notified of cancellation or postponements of hearings in which they are interested.

MC 109994 Sub 39, Sizer Trucking, Inc., assigned February 1, 1972, at Chicago, Ill.
MC 668 Sub 94, Inter-City Transportation Co., Inc., assigned January 24, 1972, at Newark, N.J., in a hearing room to be later designated.

MC 119619 Sub 45, Distributors Service Co., assigned January 31, 1972, at Chicago, Ill.
MC-F-11102, The Aetna Freight Lines, Inc.—Control and Merge—Watson Bros. Van Lines and Heavy Hauling Co., assigned February 2, 1972, at Chicago, Ill.

MC 30844 Sub 358, Kroblin Refrigerated Express, MC 107295 Sub 464, Pre-Fab Transit, now assigned for continued January 12, 1972, at the offices of Interstate Commerce Commission, Washington, D.C.

MC 134163 Sub 3, Joseph Richardson, now assigned December 6, 1971, at Philadelphia, Pa., hearing room transferred to Courtroom 8, Third Floor, U.S. Courthouse, Ninth and Chestnut Streets, instead of Courtroom No. 7.

MC 134163 Sub 4, Joseph Richardson, now assigned December 8, 1971, at Philadelphia, Pa., hearing room transferred to Courtroom 8, Third Floor, U.S. Courthouse, Ninth and Chestnut Streets, instead of Courtroom No. 7.

MC-C-7182, Illinois-California Express, Inc.—Investigation and Revocation of Certificates—assigned November 15, 1971, at Denver, is postponed indefinitely.

MC 119789 Sub 70, Caravan Refrigerated Cargo, Inc., now assigned hearing December 14, 1971, in Committee Room No. 5, State Capitol Building, North Third Street, Baton Rouge, LA.

MC 70083 Sub 19, Drake Motor Lines, now assigned January 19, 1972, at Miami, Fla., hearing room to be designated later.

MC 116763 Sub 196, Carl Subler Trucking, now assigned January 13, 1972, at Miami, Fla., hearing room to be designated later.

MC 127957 Sub 2, Dominick Spinelli, doing business as Direct Way Auto Shippers, now assigned January 11, 1972, at Miami, Fla., hearing room to be designated later.

MC 135544, Harley Davidson of Miami and Orlando, now assigned January 17, 1972, at Miami, Fla., hearing room to be designated later.

MC-F-10863, L. A. Tucker Truck Lines—Investigation of Control—Sam Tanksley Trucking, now assigned January 17, 1972, at St. Louis, Mo., canceled and application dismissed.

MC 111375 Sub 48, Pirkle Refrigerated Freight Lines, Inc., assigned January 28, 1972, at Chicago, Ill.

MC 112822 Sub 194, Bray Lines, Inc., assigned January 27, 1972, at Chicago, Ill.

MC 113678 Sub 422, Curtis, Inc., assigned January 24, 1972, at Chicago, Ill.

MC 117574 Sub 201, Daily Express, Inc., assigned January 25, 1972, at Chicago, Ill.

MC 124211 Sub 184, Hilt Truck Line, Inc., assigned January 26, 1972, at Chicago, Ill.

MC 3700 Sub 64, Manhattan Transit Co., assigned January 31, 1972, at Newark, N.J., hearing room to be later designated.

MC-F-11160, Chicago Kansas City Freight Line, Inc.—Purchase—Pride Motors, Inc., and MC 3005 Sub 10, Chicago Kansas City Freight Line, Inc., assigned January 31, 1972, at Chicago, Ill.

MC-F-10502, Ringsby Truck Lines, Inc.—Control—United Buckingham Freight Lines, Inc., et al., MC-F-10536, Central Transport, Inc.—Purchase (Portion)—Norwalk Truck Lines, Inc., MC-F-10537, International Cartage, Inc.—Purchase (Portion)—Norwalk Truck Lines, Inc., MC-F-11052, United Buckingham Freight Lines, Inc.—Merger—Norwalk Truck Lines, Inc., Norwalk Truck Lines, Inc.—Merger—Norwalk Truck Lines, of Delaware, now being assigned hearing January 17, 1972, at Denver, Colo., in a hearing room to be later designated.

MC 120080 Sub 4, Morgan Express, Inc., assigned January 17, 1972, at the Holiday Inn, 1015 Elm Street, Dallas, TX.

MC 115162 Sub 212, Poole Truck Line, Inc., assigned November 29, 1971, at New Orleans, La., postponed indefinitely.

MC 46280 Sub 70, Key Line Freight, Inc., assigned January 31, 1972, at Chicago, Ill.

MC 95084 Sub 81, Hove Truck Line, assigned January 24, 1972, at Chicago, Ill.

MC 116073 Sub 165, Barrett Mobile Home Transport, Inc., assigned January 26, 1972, at Chicago, Ill.

[SEAL] ROBERT L. OSWALD,
Secretary.

[FR Doc.71-16583 Filed 11-11-71;8:51 am]

[Sec. 5a Application 38; Amdt. 1]

CALIFORNIA HOUSEHOLD GOODS CARRIERS' BUREAU

Notice of Agreement Filed

NOVEMBER 1, 1971.

The Commission is in receipt of a supplemental application, in lieu of a prior application filed September 24, 1968, in the above-entitled proceeding for approval of amendments to the agreement therein approved.

Filed September 20, 1971 by:

R. Y. Schureman, Robert W. Hancock, 1546 Wilshire Boulevard, Los Angeles, CA 90017.

The amendments involve: Revision of the entire agreement between and among motor common carriers of household goods to reflect incorporation of the carrier-member group and proposed broadening of the territorial scope for collective ratemaking activity in interstate or foreign commerce presently limited only between points in California to embrace service between all points in the United States including Hawaii, but excluding Alaska.

The complete application may be inspected at the Office of the Commission in Washington, D.C.

Any person desiring to protest and participate in this proceeding shall notify the Commission in writing within 20 days from the date of publication of this notice in the FEDERAL REGISTER. As provided by the general rules of practice of the Commission, persons other than applicants should fully disclose their interest, and the position they intend to take with respect to the application. Otherwise, the Commission, in its discretion, may proceed to investigation and determine the matters involved without public hearing.

By the Commission.

[SEAL] ROBERT L. OSWALD,
Secretary.

[FR Doc.71-16582 Filed 11-11-71;8:51 am]

CIVIL AERONAUTICS BOARD

[Docket No. 23780 etc.]

STUDENT, YOUTH, AND SENIOR-CITIZEN FARES IN FOREIGN AIR TRANSPORTATION

Notice of Prehearing Conference

Notice is hereby given that a prehearing conference in the above-entitled matter is assigned to be held on December 16, 1971, at 10 a.m. (local time), in Room 1027, Universal Building, 1825 Connecticut Avenue NW., Washington, DC, before Examiner Edward T. Stodola.

In order to facilitate the conduct of the conference parties are instructed to submit to the examiner and other parties (1) proposed statements of issues; (2) proposed stipulations; (3) requests for information; (4) statement of positions of parties; and (5) proposed procedural dates. Bureau Counsel will circulate his material on or before November 30, 1971, and the other parties on or before December 7, 1971. The submissions of the other parties shall be limited to points on which they differ with Bureau Counsel.

Dated at Washington, D.C., November 8, 1971.

[SEAL] RALPH L. WISER,
Chief Examiner.

[FR Doc.71-16581 Filed 11-11-71;8:51 am]

DEPARTMENT OF COMMERCE

Maritime Administration

CONSTRUCTION OF LIQUEFIED NATURAL GAS (LNG) VESSELS

Computation of Foreign Cost; Notice of Intent

Correction

In F.R. Doc. 71-16508 appearing on page 21530 in the issue of Wednesday, November 10, 1971, the phrase "gas transport or Moss-Rosenberg design" appearing in the eighth and ninth lines of the first paragraph should read "Gas Transport or Moss-Rosenberg design".

[Docket No. S-271]

STATES STEAMSHIP CO.

Notice of Application

Notice is hereby given that States Steamship Co. has applied for operating-differential subsidy for a minimum of 20 and a maximum of 36 sailings per year and up to two additional vessels in addition to the vessels and sailings now authorized on its subsidized services on Trade Route No. 29 (U.S. Pacific/Far East).

Any person, firm, or corporation having any interest in such application and desiring a hearing on issues pertinent to section 605(c) of the Merchant Marine Act, 1936, as amended (46 U.S.C. 1175), should by the close of business on November 19, 1971, notify the Secretary, Maritime Subsidy Board in writing, in triplicate, and file petition for leave to intervene in accordance with the rules of practice and procedure of the Maritime Subsidy Board.

In the event a section 605(c) hearing is ordered to be held, the purpose thereof will be to receive evidence relevant to (1) whether the application is one with respect to a vessel to be operated on a service, route, or line served by citizens of the United States which would be in addition to the existing service, or services, and if so, whether the service already provided by vessels of U.S. registry in such service, route, or line is inadequate, and (2) whether in the accomplishment of the purpose and policy of the Act additional vessels should be operated thereon.

If no request for hearing and petition for leave to intervene is received within the specified time, or if the Maritime Subsidy Board determines that petitions for leave to intervene filed within the specified time do not demonstrate sufficient interest to warrant a hearing, the Maritime Subsidy Board will take such action as may be deemed appropriate.

By Order of the Maritime Subsidy Board/Maritime Administration.

Dated: November 10, 1971.

JAMES S. DAWSON, Jr.
Secretary.

[FR Doc.71-16623 Filed 11-11-71;8:51 am]

Office of the Secretary
CHILDREN'S SLEEPWEAR

Notice of Standard; Correction

In F.R. Doc. 71-10925 appearing at pages 14062-14073 in the issue for Thursday, July 29, 1971, the following nonsubstantive corrections are made:

In paragraph 4(a)(1) of the Standard for the Flammability of Children's Sleepwear (Doc. FF 3-71) on page 14063, in the first sentence, after the words "dimensions of" delete the remainder of the sentence and substitute the following, "32.9 cm. (12¹⁵/₁₆ in.) wide,

32.9 cm. (12¹⁵/₁₆ in.) deep, and 76.2 cm. (30 in.) high."

In paragraph 4(a)(2) on page 14064, delete the second sentence in the paragraph and substitute the following sentence in lieu thereof, "It shall consist of two U-shaped 0.20 cm. (14 ga USS) thick steel plates, 42.2 cm. (16⁵/₁₆ in.) long, and 8.9 cm. (3.5 in.) wide, with aligning pins."

On pages 14068, 14069, 14070, 14071, and 14072, delete Drawings Nos. 2, 3, 4, 5, and 6 respectively and substitute therefor the hereto attached Drawings Nos. 2, 3, 4, 5, and 6.

Issued: November 4, 1971.

MAURICE H. STANS,
Secretary of Commerce.

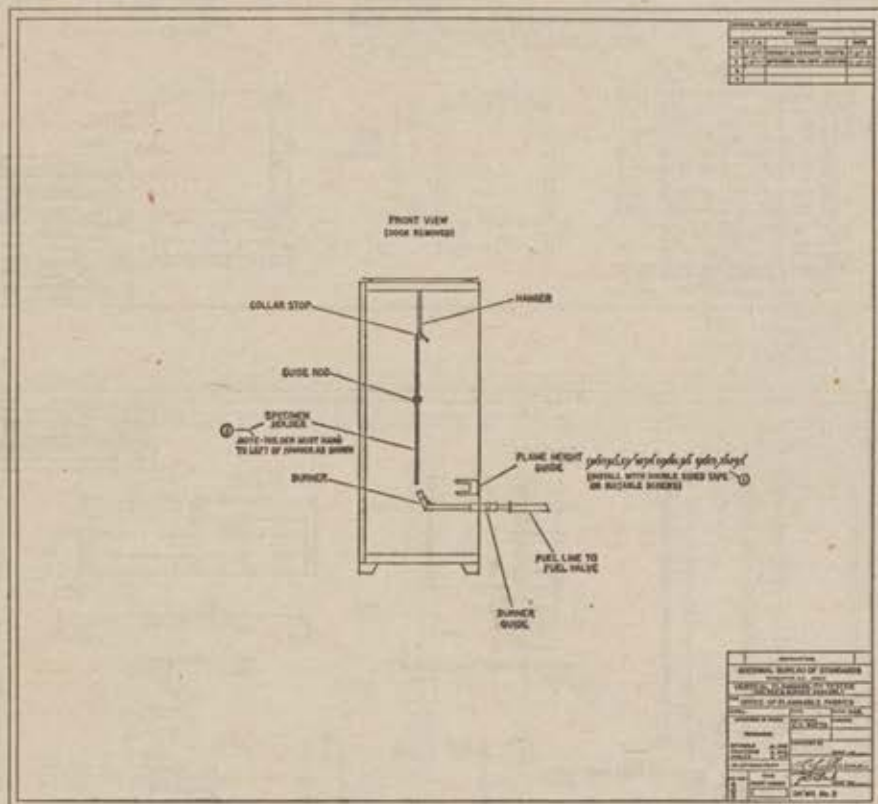

NOTICES

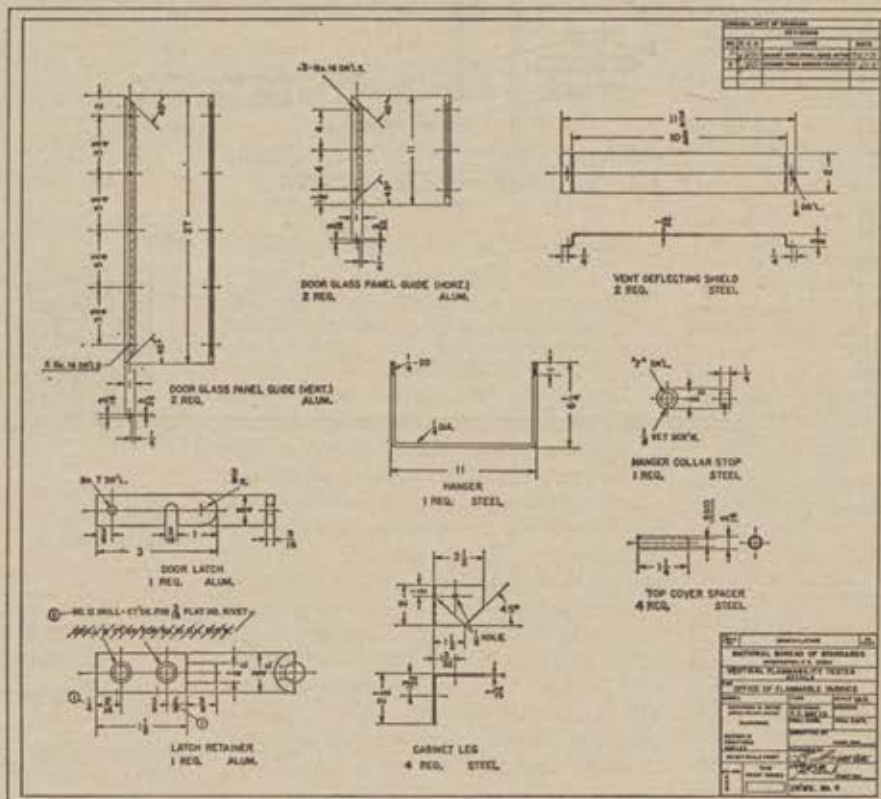
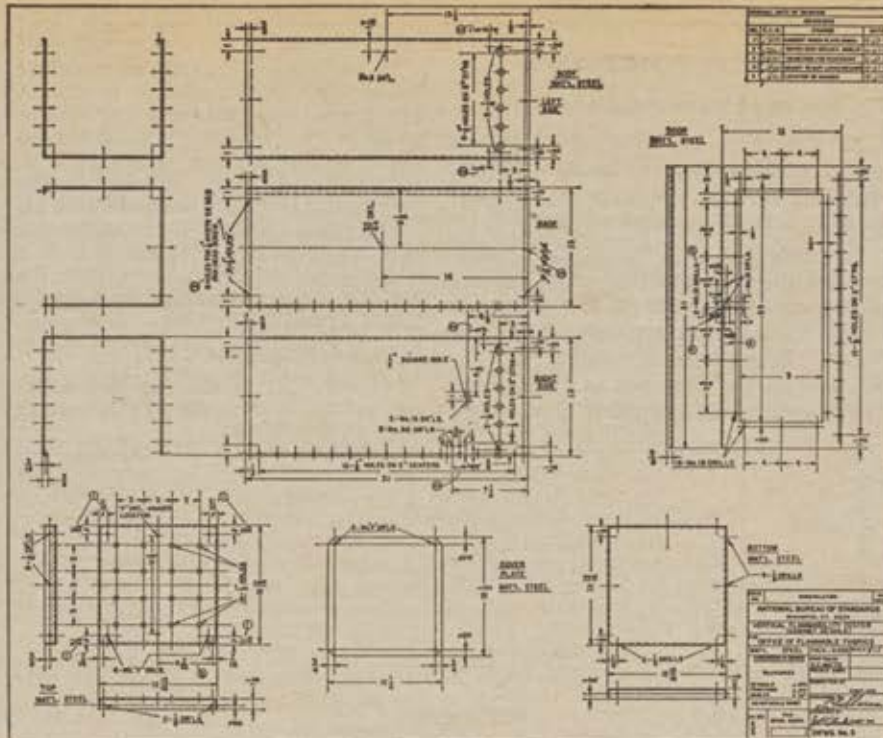

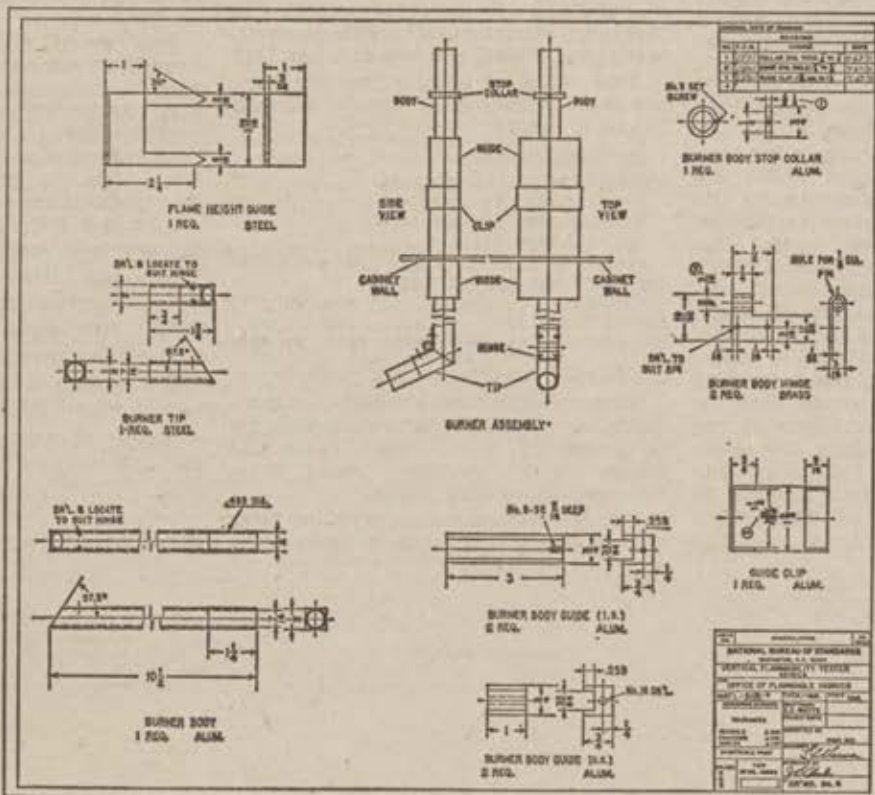
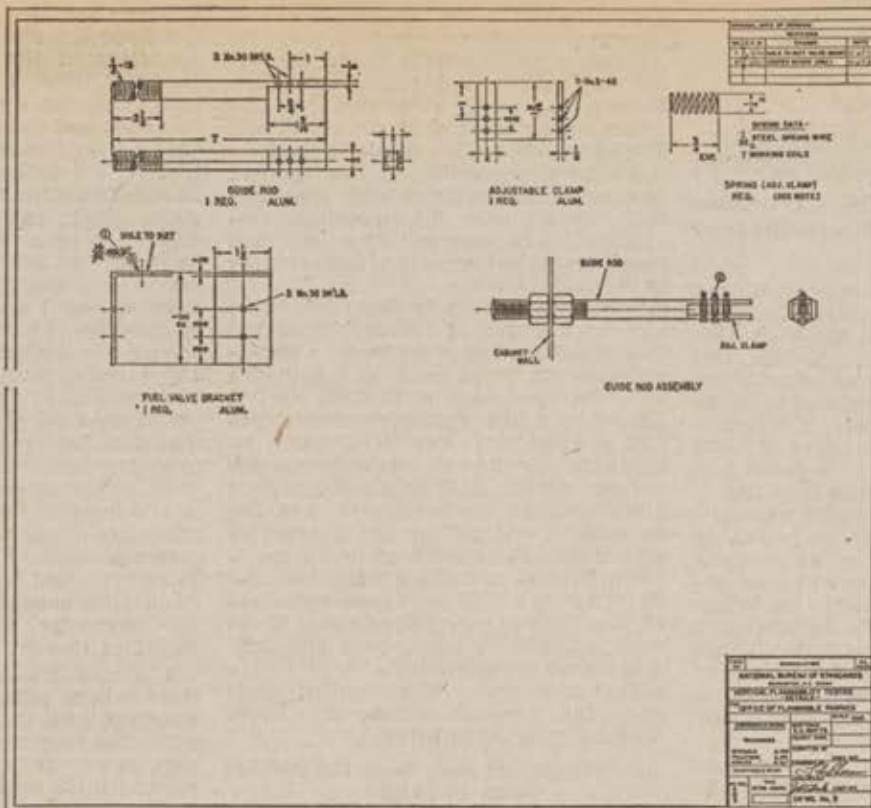

[FR Doc.71-16366 Filed 11-11-71; 8:45 am]

DEPARTMENT OF LABOR

Employment Standards Administration

MINIMUM WAGES FOR FEDERAL AND FEDERALLY ASSISTED CONSTRUCTION

Area Wage Determination Decisions and Modifications; New Determinations

There are set forth below general Area Wage Determination Decisions Nos. AM-6116, AM-6130, AM-6131, AM-6140, AM-6141, AM-6142, AM-7487, AM-7488, and AM-7489 of the Secretary of Labor. These decisions specify, in accordance with applicable law and on the basis of information available to the Department of Labor from its study of local wage conditions and from other sources, the basic hourly wage rates and fringe benefit payments which are determined to be prevailing for the described classes of laborers and mechanics employed in construction activity of the character and in the localities specified therein. The decisions are applicable to Federal and federally assisted construction in described localities situated within the States of Arizona, California, Nebraska, South Dakota, and Texas.

The determinations in these decisions of such prevailing rates and fringe benefits have been made by authority of the Secretary of Labor pursuant to the provisions of the Davis-Bacon Act of March 3, 1931, as amended (46 Stat. 1494, as amended, 40 U.S.C. 276a) and of other Federal statutes referred to in 29 CFR 1.1 (including the statutes listed at 36 F.R. 306 following Secretary of Labor's Order No. 24-70) containing provisions for the payment of wages which are dependent upon determinations by the Secretary of Labor under the Davis-Bacon Act; and pursuant to the provisions of Part 1 of Subtitle A of Title 29 of the Code of Federal Regulations, Procedure for Predetermination of Wage Rates, and of Secretary of Labor's Orders 12-71 and 15-71 (36 F.R. 8755, 8756). The prevailing rates and fringe benefits determined in these decisions shall, in accordance with the provisions of the foregoing statutes, constitute the minimum wages payable on Federal or federally assisted construction projects to laborers and mechanics of the specified classes engaged on contract work of the

character and in the localities described therein.

Good cause is hereby found for not utilizing notice and public procedure thereon prior to the issuance of these determinations as prescribed in 5 U.S.C. 533, and not providing for delay in effective date as prescribed in that section, because the necessity to issue construction industry wage determinations frequently and in large volume causes such procedures to be impractical and contrary to the public interest.

These wage determinations are effective for a period of 120 days from the date of publication in the FEDERAL REGISTER and are to be used in accordance with the provisions of 29 CFR Part 5. Accordingly, the applicable determination together with any modification issued subsequent to this date during this 120-day period, shall be made a part of every contract for performance of the described work within the geographic area indicated as required by an applicable Federal prevailing wage law and 29 CFR Part 5. The wage rates contained therein shall be the minimum paid under such contract by contractors and subcontractors on the work.

The area wage determination decisions for localities within the above States are set forth below.

MODIFICATION TO AREA WAGE DETERMINATION DECISIONS

Modification to area wage determination decisions for specified localities in Colorado, Michigan, Missouri, Pennsylvania, and Texas, and Washington, D.C.

Area wage determination decisions published in the FEDERAL REGISTER on the following dates:

Decision No.	Date
AM-376, AM-377, AM-379, AM-381, AM-382, AM-383, AM-384, AM-386, AM-387, AM-388, AM-389, AM-390, AM-391	Aug. 18, 1971
AM-1843, AM-1852, AM-1860, AM-1862	Aug. 20, 1971
AM-3567, AM-3616	Aug. 25, 1971
AM-3630, AM-3631, AM-3632	Aug. 27, 1971

are hereby modified as set forth below.

These modifications are based upon information obtained concerning changes in prevailing hourly wage rates and fringe benefit payments since these determinations were issued.

The determinations of prevailing rates and fringe benefits made in these modi-

fications have been made by authority of the Secretary of Labor pursuant to the provisions of the Davis-Bacon Act of March 3, 1931, as amended (46 Stat. 1494, as amended 46 U.S.C. 276a) and of other Federal statutes referred to in 29 CFR 1.1 (including the statutes listed at 36 F.R. 306 following the Secretary of Labor's Order No. 24-70) containing provisions for payment of wages which are dependent upon determinations by the Secretary of Labor under the Davis-Bacon Act; and pursuant to the provisions of Part 1 of Subtitle A of Title 29 of the Code of Federal Regulations, Procedure for Predetermination of Wage Rates, and of Secretary of Labor's Orders 13-71 and 15-71 (36 F.R. 8755, 8756). The prevailing rates and fringe benefits determined in the foregoing area wage determination decisions, as hereby modified, shall, in accordance with the provisions of the foregoing statutes, constitute the minimum wages payable on Federal and federally assisted construction projects to laborers and mechanics of the specified classes engaged in contract work of the character and in the localities described therein.

The modifications are effective from their date of publication in the FEDERAL REGISTER until the end of the period for which the determinations being modified were issued and are to be used in accordance with the provisions of 29 CFR Part 5. The modifications to the area wage determination decisions listed above are set forth below.

Any person, organization, or governmental agency having an interest in the wages determined as prevailing is encouraged to submit wage rate information for consideration by the Department. Further information and self-explanatory forms for the purpose of submitting this data may be obtained by writing to the U.S. Department of Labor, Employment Standards Administration, Wage and Hour Division, Division of Wage Determinations, Washington, D.C. 20210. The cause for not utilizing the rule-making procedures prescribed in 5 U.S.C. section 553 is set forth in the document being modified.

Signed at Washington, D.C., this 5th day of November 1971.

HORACE E. MENASCO,
Administrator,
Employment Standards Administration.

DEPARTMENT OF LABOR

State: Arizona; County: Maricopa; Decision No. AM-6116; date of decision: November 12, 1971.

Description of work: Residential construction consisting of single family homes and garden-type apartments up to and including four stories.

MODIFICATIONS

Classification	Basic hourly rates	Fringe benefits payments				
		H & W	Pensions	Vacation	App. Tr.	Other
<i>Phoenix, Glendale, Mesa, Scottsdale, Tempe, Luke AFB, and Williams AFB</i>						
7-Arizona—MARI-1-2-3-p:						
Asbestos workers	\$7.93	\$0.35	\$0.40			
Boilermakers	7.20	.30	.70	\$0.45	\$0.02	
Boilermakers' helpers	6.90	.30	.70	.45	.02	
Bricklayers and stonemasons	8.35	.35	.30		.03	
Carpenters:						
Carpenters	7.45	.30	.45		.025	
Millwrights	7.825	.30	.45		.025	
Piledrivermen	7.70	.30	.45		.025	
Cementmasons	7.285	.30	.50		.025	
Drywall tapers	6.00	.225				
Drywall texture sprayers	6.10	.225				
Electricians (including Luke AFB)	6.55	.20	1%		10%	
Electricians (Williams AFB)	7.00	.20	1%		15%	
Elevator constructors	7.58	.185	\$0.30	2%+s		
Elevator constructors' helpers	7.58	.185	.30	2%+s		
Elevator constructors' helpers (prob.)	70% J R					
Ironworkers:						
Ornamental-structural	8.58	.43	.425		.04	
Reinforcing	8.58	.43	.425		.04	
Marble and tile setters	5.84	.25	.20		.01	
Painters:						
Brush	6.25	.275	.20	\$0.15	.02	
Steel and bridge, brush	6.60	.275	.20	.15	.02	
Spray	6.50	.275	.20	.15	.02	
Plasterers	5.81	.30	.30		.035	
Plumbers; pipefitters; steamfitters (zone bases: Phoenix, Tucson, Douglas, Flagstaff, Yuma):						
Zone I—(0-15 miles)	7.74	.45	.70		.06	
Zone II—(15-30 miles)	8.04	.45	.70		.06	
Zone III—(30-45 miles)	8.39	.45	.70		.06	
Zone IV—(45 miles and beyond)	9.49	.45	.70		.06	
Sheet metal workers	7.59	.27	.32		.02	
Soft floor layers	5.25	.275	.20		.02	
Sprinkler fitters	7.95	.25	.40		.05	
Terrazzo and mosaic workers	6.21					
Line construction:						
Cable splicer	7.66	.23	1%+4%b		10%	
Linemen	7.40	.23	1%+4%b		10%	
Equipment operator	6.96	.23	1%+4%b		10%	
Groundman	6.04	.23	1%+4%b		10%	
1-Arizona—LAB-1-2-3-m:						
Laborers:						
Group I:						
All helpers not herein separately classified; cesspool diggers and installers; chat box man; checker, tool dispatcher; concrete dump man/belt, pipe and/or hose man; dumpman and/or spotter; fence builder, guardrail builder highway; form strippers; labor, general, or construction; landscape gardener and nurseryman; packing rod steel and pans; riprap stone-man						
	5.23	.30	.45		.05	
Group II:						
Cement finisher tender; concrete curer (impervious membrane); cutting torch operator; fine grader (highway, engineering and sewer work only); kettleman-tarman; power type concrete buggy						
	5.34	.30	.45		.05	
Group III:						
Bander; chucktender (except tunnel); creosote tie man; guinea chaser; powderman helper; riprap stone paver; sandblaster (pot tender); spikers and wrencher						
	5.45	.30	.45		.05	
Group IV:						
Cement dumpers (Skip-type mixer or handling bulk cement); chain saw machines (on clearing and grubbing); concrete vibrating machines; cribber and shorer (except tunnel); floor Sanders—concrete; hydraulic jacks, and similar mechanical tools not separately herein classified; operators and tenders of pneumatic and electric tools; pipe caulker and/or backup man (pipeline); pipe wrapper; pneumatic gopher; rigger/signalman (pipeline)						
	5.53	.30	.45		.05	
Group V:						
Air and water washout nozzle man; asphalt rakers and ironers; driller; grade setter (pipe-line); hand guided trencher and similar operated equipment; jackhammer and/or pavement breakers; pipelayer (including but not limited to nonmetallic, transite and plastic pipe, water pipe, sewer pipe, drain pipe, underground tile and conduit); rock slinger; scaler (using bos'n chair of safety belt); tampers (mechanical—all types)						
	5.67	.30	.45		.05	
Group VI:						
Concrete cutting torch; concrete saw (hand guided); driller (core, diamond, wagon or air track); drill doctor and/or air tool repairman; gunman and mixer man (gunite); sandblaster (nozzle man)						
	5.975	.30	.45		.05	
Group VII:						
Concrete road form setter; gunite nozzle man or rodman; drillers, joy mustang, P R 143, 2200 Gardner-Denver, hydraulic; powderman; scaler (drillers); welders and/or pipe layers installing process piping						
	6.485	.30	.45		.05	
Mason tenders	5.835	.30	.45		.05	
Plasterers' tenders	6.15	.30	.45		.05	
Employees working underground shall receive twenty cents (20¢) per hour additional above the regular rate, except where herein specifically covered.						
Laborers employed where they may have a free fall over thirty (30) feet or on construction scaffolds above thirty (30) feet or bos'n chair above thirty (30) feet, or where gas masks are necessary, shall receive fifty cents (50¢) per hour in addition to their regular rate, except where inherent in classifications.						

See footnotes at end of table.

Classification	Basic hourly rates	Fringe benefits payments				
		H & W	Pensions	Vacation	App. Tr.	Other
1-Arizona—LAB-1-2-3-m—Continued						
Laborers—Continued						
Tunnel and Shaft workers:						
Group I:						
Bull gang, muckers, trackman; dumpmen; concrete crew (Includes rodders and spreaders); grout crew; swamper (brakeman and switchmen on tunnel work).....	5.425	.30	.45		.05	
Group II:						
Nipper; chucktender, cabletender; vibratorman, jackhammer, pneumatic tools (except driller).....	5.56	.30	.45		.05	
Group III:						
Grout gunman.....	6.66	.30	.45		.05	
Group IV:						
Timberman, retimberman—wood or steel blaster, driller powderman; cherry pickerman; powderman—primer house; steel form raiser and setter; Kemper and other pneumatic concrete placer operator; miner—finisher.....	5.76	.30	.45		.05	
Group IV-A:						
Miners—Tunnel (hand or machine).....	5.96	.30	.45		.05	
Group V:						
Diamond drill.....	6.065	.30	.45		.05	
Group V-A:						
Shaft and raise miner welder.....	6.295	.30	.45		.05	
1-Arizona—PEO-1-2-3-p:						
Power equipment operators:						
Group I:						
Air compressor operator; field equipment servicemen helper; heavy-duty repair helper; heavy-duty welder helper; oiler; pump operator.....	5.98	.40	.50		.02	
Group II:						
Conveyor operator; generator operator—portable; power grizzly operator; self-propelled chip spreading machine-conveyor operator; watch fireman; welding machine operator—gasoline and diesel power.....	6.28	.40	.50		.02	
Group III:						
Concrete mixer operator—skip type; dinky operator (under 20 tons weight); driver—motor paver, slurry seal machine, and similar type equipment; motor crane driver; power sweeper operator—self-propelled; Ross carrier or forklift operator; skip loader operator, all types with rated capacity 1½ cu. yds. or less; wheel-type tractor operator (Ford, Ferguson, or similar type) with attachments such as Fresno, push blade, post hole auger, mower, etc., excluding compacting equipment.....	6.68	.40	.50		.02	
Group IV:						
A-frame boom truck or winch truck operator; asphalt plant fireman; elevator hoist operator (including Tuskey hoist or similar types); grade checker (excluding civil engineer); multiple power concrete saw operator; pavement breaker, mechanical compactor operator, power propelled; roller operator, all types except as otherwise classified; screed operator; self-propelled chip spreading machine operator (including slurry seal machine operator) stationary pipewrapping and cleaning machine operator; tugger operator.....	7.12	.40	.50		.02	
Group V:						
Aggregate plant operator (including crushing, screening and sand plants, etc.); asphalt laydown machine operator; asphalt plant mixer operator; beltcrete machine; boring machine operator; concrete mechanical tamping, spreading or finishing machine (including Clary, Johnson or similar types); concrete pump operator; concrete batch plant operator, all types and sizes; conductor, brakeman, or handler; drilling machine operator, including water wells; elevating grader operator, all types and sizes (except as otherwise classified); field equipment serviceman; highline cableway signalman; Kolman belt loader operator or similar type, w/belt width 48 in. or over; locomotive engineer (including Dinky—20 tons weight and over); moto-paver and similar type equipment operator; operating engineer rigger; pneumatic-tired scraper operator (Turnapull, Euclid, Cat, D-W, Hancock and similar equipment) up to and including 12 cu. yds.; power jumbo form setter operator; pressure grout machine operator (as used in heavy engineering construction); road oil mixing machine operator; roller operator—on all types asphalt pavement; self-propelled compactor, with blade; skip loader operator—all types with rated capacity over 1½ but less than 4 cu. yds.; slip form operator (power-driven lifting device for concrete forms); soil cement road mixing machine operator—single pass type; stationary central generating plant operator—rated 300 kw. or more; surface heater and planer operator; traveling pipewrapping machine operator.....	7.56	.40	.50		.02	
Group V-A:						
Heavy duty mechanic and/or welder; pneumatic tired scraper, all sizes and types over 12 cu. yds. up to and including 45 cu. yds. MRC (Turnapull, Euclid, Cat, D-W, Hancock, and similar equipment); tractor operator (pusher, bulldozer, scraper) up to 400 net horsepower rating; trenching machine operator.....	7.82	.40	.50		.02	
Group VI:						
Auto-grade machine (CMI and similar equipment); boring machine operator (including Mole, Badger and similar type); concrete mixer operator-paving type, and mobile mixer; concrete pump operator with boom attachment (truck mounted); crane operator-crawler and pneumatic type, under 100-ton capacity MRC; crawler type tractor operator—with boom attachment; derrick operator; forklift operator for hoisting personnel; Grade all operator; helicopter hoist; highline cableway operator (less than 20 tons rated capacity); mass excavator operator (150 Bucyrus Erie and similar types); mechanical hoist operator (2 or more drums); motor grader operator—any type power blade; motor grader operator with elevating grader attachment; mucking machine operator; overhead crane operator; piledriver engineer (portable, stationary or skid rig); pneumatic-tired scraper operator—all sizes and types (Turnapull, Euclid, Cat, D-W, Hancock and similar equipment) over 45 cu. yds. MRC; power driven ditch lining or ditch trimming machine operator; skip loader operator—all types with rated capacity 4 cu. yds. but less than 8 cu. yds.; slip form paving machine operator (including Gunnert, Zimmerman and similar types); specialized power digger operator—attached to wheel-type tractor; tower crane (or similar type) operator; tractor operator (pusher, bulldozer, scraper) 400 net horsepower and over; tugger operator (2 or more); universal equipment operator—shovel, backhoe, dragline, clam-shell, etc. up to 8 cu. yds.....	8.10	.40	.50		.02	
Group VII:						
Crane operator—pneumatic or crawler (100-ton hoisting capacity and over MRC rating); helicopter pilot—FAA qualified when used in construction work; highline cableway operator, over 20-ton rated capacity and using traveling head and tail tower; remote-control earth moving equipment operator; skip loader operator—all types with rated capacity of 8 cu. yds. or more; universal equipment—shovel, backhoe, dragline, clamshell, etc., 8 cu. yds. and over.....	8.60	.40	.50		.02	
Multiple-unit earth moving equipment:						
Tractor operator, pneumatic-tired or track-type, 2 units—fifty cents (50¢) per hour more than the base single-unit rate established in group V, group V-A, or group VI, and one dollar (\$1.00) per hour for each additional unit.						
All operators, oiler, and motor crane drivers on equipment with booms of 80 and over, including (if shall receive \$0.0075 (three-fourths of a cent) per foot, per hour, premium pay additional to the regular rate of pay.						
Oiler shall be required on all track or crawler-type cranes, backhoes, shovels, clamshells, draglines, gradalls, etc.						
Oiler drivers shall be required on all truck mounted or self-propelled excavating and/or hoisting equipment having the configuration for 2 men.						

See footnotes at end of table.

Classification	Basic hourly rate	Fringe benefits payments				
		H & W	Pensions	Vacation	App. Tr.	Other
I-Arizona—TD-1-2-3-d:						
Truckdrivers:						
Group I:						
Pickup; station wagon; teamsters	5.37	.30	.45		.02	
Group II:						
Buggymobile, 1 cu. yd. or less; bulk cement spreader (2- or 3-axle); bus driver; dump (2- or 3-axle); flatrack (2- or 3-axle); water (under 2,500 gal.)	5.48	.30	.45		.02	
Group III:						
Bulk cement spreader (4 axle); dump (4 axle); dumptor or dumpster, less than 7 cu. yds.; flatrack (4 axle); water (2,500 gal. but less than 4,000 gal.)	5.64	.30	.45		.02	
Group IV:						
Bulk cement spreader (5 axle); dump (5 axle); dumptor or dumpster, 7 cu. yds. but less than 16 cu. yds.; Flaherty spreader or similar type equipment or leverman; flatrack (5 axle); slurry-type equipment or leverman; transit mix, 8 cu. yds. or less mixer capacity	5.93	.30	.45		.02	
Group V:						
Bulk cement spreader (6 axle); dump (6 axle); flatrack (6 axle); rock truck (Dart, Euclid and other similar type end dumps, single unit) less than 16 cu. yds.	6.06	.30	.45		.02	
Group V-A:						
Oil tanker or spreader truck driver and/or bootman, retortman or leverman	6.20	.30	.45		.02	
Group VI:						
Bulk cement spreader (7-axle); concrete pump truck driver, (when integral part of transit mix truck); dump (7-axle); flat track (7-axle); hydrolift, Swedish crane, Iowa 300 and similar types; Ross carrier forklift or lift truck; transit mix over 10.5 cu. yds. but less than 14 cu. yds. mixer capacity	6.31	.30	.45		.02	
Group VII:						
Bulk cement spreader (8-axle); dump (8-axle); flatrack (8-axle)	6.65	.30	.45		.02	
Group VIII:						
Off-highway equipment driver (2- or 4-wheel power unit, i.e. Cat DW series, Euclid, International, and similar type equipment, transporting material when top loaded or by external means, including pulling water tanks, fuel tanks, or other Teamsters classifications; bulk cement spreader (9-axle); dump (9-axle); dumptor or dumpster, 16 cu. yds. and over; eject-alls; flat-rack (9-axle); rock truck (Dart, Euclid, or other similar end dump types) 16 cu. yds. and over	7.065	.30	.45		.02	
Heavy-duty mechanic welder	7.94	.30	.45		.02	
Heavy-duty mechanic/welder helper	6.10	.30	.45		.02	
Field equipment serviceman or fuel truck driver	7.68	.30	.45		.02	
Combination man—30 cents over the highest rated work.						
Multiple-unit equipment driver—2 units 50 cents per hour more than the base single unit rate established in group 8 above; and \$1 per hour for each additional unit.						

Paid holidays:

A—New Year's Day; B—Memorial Day; C—Independence Day; D—Labor Day;
E—Thanksgiving Day; F—Christmas Day.

Footnotes:

a. Employer contributes 4 percent of basic hourly rate for 5 years' service and 2

percent of basic hourly rate for 6 months to 5 years' service as Vacation Pay Credit. Six paid holidays: A through F.

b. Of gross labor payroll, employer contributes 1 percent to NEBF and 4 percent to Management Pension Fund.

State: California; County: San Diego; Decision No. AM-6,130, date of decision: November 12, 1971.

Description of work: Residential construction consisting of single-family homes and garden-type apartments up to and including four stories.

MODIFICATIONS

Classifications	Basic hourly rates	Fringe benefits payments				
		H & W	Pensions	Vacation	App. Tr.	Other
<i>San Diego County</i>						
II-California—SDI-1-2-3-4:						
Asbestos workers	\$9.77	\$0.48	\$0.35		\$0.025	
Boilermakers	7.29	.30	.70	\$0.45	.02	
Boilermakers' helpers	6.90	.30	.70	.45	.02	
Bricklayers; stonemasons	6.35	.37	.40	.35	.01	
Brick, block and stonemasons' tenders	5.66	.30	.35	.35		
Carpenters:						
Carpenters	6.51	.56	.65	.45	.015	
Piledrivermen	6.64	.56	.65	.45	.015	
Millwrights	6.76	.66	.65	.45	.015	
Pneumatic nailer; hardwood floor layers	6.76	.56	.65	.45	.015	
Cementmasons:						
Cementmasons	6.52	.45	.43	.55	.005	
Cementmason color work-curb machine operator	6.645	.45	.43	.55	.005	
Composition, mastie or epoxy finishing machine operator	6.77	.45	.43	.55	.005	
Drywall installers	7.25	.56	.65	.50	.04	
Electricians:						
Electricians	8.75	.20	1% & 23			
Cable splicer	9.05	.20	1% & 23			
Sound technicians	6.45		1%			
Elevator constructors	7.28	.185	\$0.20	2% & a		
Elevator constructors' helpers	70% J R	.185	.30	2% & a		
Elevator constructors' helpers (prob.)	50% J R					
Glaziers	\$6.19	.15	.50	b		
Ironworkers:						
Reinforcing	7.98	.43	.425	.50	.02	
Fence erectors	7.89	.43	.425	.50	.02	
Ornamental; structural	8.03	.43	.425	.50	.02	
Irrigation and lawn sprinklers	6.50	10%	10%	13%	1%	
Lathers (northern portion of San Diego County from center of city of Del Mar)	6.92	\$0.30	\$0.75	\$0.50		
Lathers (remainder of county)	6.41	.20	.15		.03	
Line construction:						
Groundmen	6.74	.20	1% & 23			
Linemen	8.75	.20	1% & 23			
Cable splicers	9.05	.20	1% & 23			
Marble setters	6.46	.20	\$0.45	.60		
Marble setters' helpers	5.09	.20	.45	.60		
Painters:						
Brush	6.93	.39	.39	.60	.03	
Paperhangers; sandblasters; tapers	7.43	.39	.39	.60	.03	
Sandblaster, swing stage, iron, steel and bridge painter, swing stage spray; spray, climbing steel and bridge	7.68	.39	.39	.60	.03	
Steeplejack	8.33	.39	.39	.60	.03	

See footnotes at end of table.

Classification	Basic hourly rates	Fringe benefits payments				
		H & W	Pensions	Vacation	App. Tr.	Other
37-California—SDI-1-2-3-4—Continued						
Painters—Continued						
Parking lot striping work and/or highway markers	4.88	.20	.20	c		
Parking lot striping work and/or highway markers' helpers; sandblaster	4.38	.20	.20	c		
Plasterers	7.50	.40	.30			
Plasterers' tenders	6.70	.25	.25	.25		
Plumbers; steamfitters; lead burners	8.20	10%	16%	13%	1%	
Roofers	5.25	\$0.19		\$0.85		
Sheet metal workers	8.30	.39	\$0.40			
Soft floor layers	6.70	.40	.30	.35	\$0.05	
Sprinkler fitters	10.55	.25	.40		.05	
Terrazzo workers	9.46	.20	.45	.00		
Tile setters	9.46	.20	.45	.00		
Tile setters' helpers	5.09	.20	.45	.00		
Riggers; welders: Receive rate prescribed for craft performing operation to which rigging or welding is incidental.						
3-California—SDI-LAB-1-2-3-e						
Laborers:						
Laborers (general, construction, toolshed checker, using dry pack), gas and oil pipeline	4.83	.30	.35	.35		
Cutting torch operator (demolition), scaler	4.88	.30	.35	.35		
Guinea chaser	4.91	.30	.35	.35		
Fine grader on highways, streets, and airports paving (sewer and drainage lines), landscape gardener and nurseryman	4.94	.30	.35	.35		
Laborer (packing rod steel and pans), tank sealer and cleaner	4.95	.30	.35	.35		
Caisson driller's helper (including bellows), boring machine helper	4.96	.30	.35	.35		
Window cleaner, chuck tender (except tunnels), septic tank digger and installer (leadmen)	4.98	.30	.35	.35		
Cesspool digger and installer	5.01	.30	.35	.35		
Concrete curer, impervious membrane, riprap stonepaver, sandblaster (pot tenders), making and caulking nonmetallic pipe joints, tarmen, mortarmen, potmen	5.02	.30	.35	.35		
Pneumatic and electric tools, concrete pump, vibrating machine and similar mechanical tools not separately classified herein; concrete saw (excluding tractor-type, rotocrafter; chipping hammer, concrete core cutter and form blower), asphalt raker, ironer, spreader-buggymobile-ment dumper (1 yd. or larger mixers and handling bulk cement), gas and oil pipeline wrapper, pot tender and form man, tree climber (mechanical tools)	5.04	.30	.35	.35		
Rock slinger, sealer (bos'n chair, safety belt, power tools)	5.09	.30	.35	.35		
Driller (not otherwise classified where drilling is for explosives)	5.12	.30	.35	.35		
Pipelayer (nonmetallic pipe including sewer, drain and underground tile)	5.14	.30	.35	.35		
Gas and oil pipeline wrapper (6 in. pipe and over)	5.17	.30	.35	.35		
Cribber-shorer	5.19	.30	.35	.35		
Steel headerboard man	5.25	.30	.35	.35		
Driller (core, diamond or wagon, Joy Model TWM-2A, Gardner Denver-Model DM 143 and similar drills), sandblaster (nozzleman)	5.28	.30	.35	.35		
Powdermen	5.31	.30	.35	.35		
Head rock slinger	5.35	.30	.35	.35		
3-California—SDI-PEO-1-2-3-d						
Power equipment operators:						
Group I:						
Brakeman; compressor engineer oiler; generator; heavy-duty repairman helper; pump; signalman; switchman	6.23	.45	.80	.30	.02	
Group II:						
Concrete mixer, skip-type; conveyor; fireman; generator, pump or compressor; skiploader—wheel-type up to 1/4 yd. w/o attachments; soils field technicians; tar pot fireman; temporary heating plant; trenching machine oiler; well point pump	6.47	.45	.80	.30	.02	
Group III:						
Elevator (inside); Ford Ferguson—w/drag; helicopter radioman (ground); oiler-crusher (asphalt or concrete plant); power concrete curing machine operator; power concrete saw; power-driven jumbo form setter; stationary pipe wrapping and cleaning machine; truck-crane oiler	6.71	.45	.80	.30	.02	
Group IV:						
Asphalt plant fireman; boring machine; chip spreading machine; concrete pump; concrete pump (truck mounted); dinky locomotive or motorman (10 ton); helicopter hoist; helicopter radioman; highline cableway signman; power sweeper; screed; rodman and chainman; trenching machine (up to 6 ft.)	6.82	.45	.80	.30	.02	
Group V:						
A-frame winch truck; Asphalt plant or concrete batch plant; asphalt spreading machine (spreader bar and similar); bit sharpener; boxman or mixerman (asphalt or concrete); concrete joint machine (canal and similar type); concrete planer; drilling machine (water wells); equipment greaser (mobile and grease rack); Ford Ferguson or similar type (w/drag-type attachments); forklift (under 5-ton capacity); hydra-hammer-aero stomper; hydrographic seeder machine (straw, pump or seed); instrumentman; machine tool; maginns internal fill slab vibrator; mechanical berm, curb or gutter (concrete or asphalt); mechanical finisher (concrete, Clary-Johnson-Bidwell or similar); pavement breaker (truck mounted); road oil mixing machine; roller; Ross carrier (jobsite); self-propelled tar pipelining machine; skiploader (wheel- or track-type over 1/4 yd. up to and including 1 1/2 yds.); slip form pump (power-driven hydraulic lifting device for concrete forms); stinger crane (Austin-Western or similar type); traveling pipe wrapping, cleaning and bending machine; truck-type loader; tugger hoist (1-drum)	7.01	.45	.80	.30	.02	
Group VI:						
Asphalt or concrete plant engineer; asphalt or concrete spreading (tamping or finishing); asphalt paving machine (Barber Greene or similar type); belt splicer or vulcanizer; BHL Lima road pactor, Wagner Pactor or similar; bridge crane; bridge-type unloader and turntable; cast-in-place pipelaying machine; combination mixer and compressor (gumite work); concrete mixer-paving; crane (up to and including 25-ton cap—long boom pay applicable); crushing plant; deck engine drill doctor; elevating grader; forklift (over 5 tons); gradall; grade checker; grouting machine; heading shield; heavy-duty repairman; hoist (single drum, buck hoist, Chicago boom and similar type); hoist (2- or 3-drum); Kolman belt loader and similar type; LeTourneau blob compactor or similar type; lift mobile; lift slab machine (Vagtberg and similar types); material hoist (1 drum); mucking machine (3/4 yd., rubber-tired, rail- or track-type); piledriver; pneumatic concrete placing machine (Hackley-Presswell or similar type); pneumatic heading shield (tunnel), pumperete gun; rotary drill (excluding Caisson-type); rubber-tired earth moving equipment (single engine, Caterpillar, Euclid, Athey wagon, Water Pulk and similar types with any and all attachments up to 50 cu. yds. struck); rubber-tired scraper (self-loading paddle wheel type, John Deere, 1046 and similar single unit); skiploader (wheel- or track-type, over 1 1/2 yds. up to and including 6 1/2 yds.); surface heaters and planer; tractor compressor drill combination; tractor (bulldozer, tamper, scraper and push tractor, single engine); trenching machine (over 6 ft. depth capacity, manufacturers rating); tunnel locomotive (10 to 30 tons); universal equipment (shovel, backhoe, dragline, clamshell, up to and including 1 cu. yd. MRC) (long boom pay applicable)	7.11	.45	.80	.30	.02	

See footnotes at end of table.

Classification	Basic hourly rates	Fringe benefits payments				
		H & W	Pensions	Vacation	App. Tr.	Other
3-California—SDI-PEO-1-2-3-d—Continued						
Power equipment operators—Continued						
Group VII:						
Crane (over 25 tons up to and including 100-ton MRC) (long boom pay applicable); derrick barge; dual drum mixer; hoist (2 or 3 drum w/boom attachment); hoist (stiff legs, guy derricks or similar type up to 100-ton capacity—oller or long boom pay applicable); loader (Athey, Euclid, Sierra, or similar type); monorail locomotive (diesel, gas, or electric); motor patrol, blade; multiple engine tractor (Euclid and similar type, except Quad 9 cat); party chief; rubber-tired earth moving equipment (multiple engine, Euclid, Caterpillar, and similar type up to 80 cu yds. struck); tractor (boom attachments—over 40 ft. boom); tractor loader (crawler and wheel-type over 6½ yds.); tower crane (2 operators required); tower crane repairman; universal equipment (shovel, backhoe, dragline, clamshell, over 1 cu. yd. MRC); welder (heavy-duty repairman) combination; wood mixer and other similar pugmill equipment.....	7.21	.45	.80	.30	.02	
Group VIII:						
Auto grader; automatic slip form crane, over 100 tons (long boom pay applicable); hoist (stiff legs, guy derricks or similar types, capable of hoisting over 100 tons, long boom pay applicable); mass excavator (less than 750 cu. yds.); mechanical finishing machine; mobile from traveler; motor patrol (multiengine); pipe mobile machine; rubber-tired earth moving equipment (multiple engine, Euclid, Caterpillar, and similar type over 80 cu. yds. struck); rubber-tired scraper (pushing one another, w/o push cat, push-pull—\$0.50 per hour additional to base rate); rubber-tired self-loading scraper (paddle wheel, auger-type self-loading, 2 or more units); tandem equipment (2 units only); tandem tractor (Quad 9 or similar type) (Art. XV-V.10); tunnel mole boring machine.....	7.35	.45	.80	.30	.02	
Group IX:						
Canal liner operator; canal trimmer operator; helicopter pilot; highline cableway; remote controlled earth moving equipment (\$1 per hour additional to base rate); wheel excavator operator (over 750 cu. yds.).....	7.70	.45	.80	.30	.02	
3-California—SDI-TD-1-2-3-d.						
Truck Drivers:						
Pickup (34 ton and under); traffic control pilot car (excluding moving heavy equipment).....	4.97	.55	.55	.80		
Truck repairman or welder helper.....	5.17	.55	.55	.80		
Industrial lift.....	5.30	.55	.55	.80		
Dump (less than 8 yds.); dump or flat bed (2 axes); concrete pumping; forklift (under 15,000 lbs.).....	5.33	.55	.55	.80		
Water truck (under 2,500 gals.).....	5.36	.55	.55	.80		
Dump (8 to and including 11 yds.); dump or flat bed (3 axes); bunkers.....	5.38	.55	.55	.80		
Ros carrier; fork lift (15,000 lbs. and over).....	5.45	.55	.55	.80		
Dump (12 to and including 15 yds.); dump or flat bed (3 axes, semi).....	5.46	.55	.55	.80		
Water truck (2,500 to 4,000 gals.); pipeline working trucks (including winch and all sizes).....	5.48	.55	.55	.80		
Dumperete (less than 6½ yds. water level).....	5.54	.55	.55	.80		
Water truck (4,000 gals. and over).....	5.60	.55	.55	.80		
Fuel truck or dynamite and explosives.....	5.63	.55	.55	.80		
Dump (16 to and including 24 yds.); dump (4 axes or more); low bed truck and trailer; transit mix (under 8 yds.); dumperete (6½ yds. or over, water level); dumpster.....	5.68	.55	.55	.80		
Dump (25 to and including 34 yds.).....	5.73	.55	.55	.80		
DW 10's or DW 20's or Euclid-type equipment or LeTourneau pulls or Terra Cobras of similar types of equipment regardless of types of attachments when performing work in the teamsters' jurisdiction or PB or similar types of dump trucks with loading attachments.....	5.75	.55	.55	.80		
Truck greaser.....	5.76	.55	.55	.80		
7 axes or double gooseneck lowbed or combination of vehicles when under permit load.....	5.805	.55	.55	.80		
Transit-mix (8 yds. and over).....	5.82	.55	.55	.80		
Tireman.....	5.86	.55	.55	.80		
Dump (35 to and including 49 yds.).....	5.88	.55	.55	.80		
Water pull tankers; A-frame or Swedish crane.....	5.95	.55	.55	.80		
Dump (59 to and including 64 yds.).....	6.03	.55	.55	.80		
Truck repairman.....	6.05	.55	.55	.80		

Paid holidays:
 A—New Year's Day; B—Memorial Day; C—Independence Day; D—Labor Day;
 E—Thanksgiving Day; F—Christmas Day.
FOOTNOTES:
 a. Employer contributes 4 percent of basic hourly rate for 5 years' service and 2 percent of basic hourly rate for 6 months to 5 years' service as Vacation Pay Credit. Six paid holidays: A through F.
 b. 80 hours' paid vacation after 1 year's continuous service with same employer.

Upon termination, after 30 days' continuous service, employee receives Vacation Pay prorated at 154 percent of 1 hour's pay for every previous 40-hour workweek employed. After 30 days' service, employees are eligible for 6 paid holidays: A through F.
 c. Employer contributes \$0.17 per hour to Holiday Fund plus \$0.10 per hour to Vacation for 1 year's service, \$0.20 per hour after 1 year but less than 5 years' service, \$0.30 per hour after 5 years but less than 10 years' service, \$0.40 per hour after 10 years' service.

State: California; Counties: Amador, Contra Costa, Marin, Sacramento, San Francisco, San Joaquin, Santa Clara, Solano, Sonoma; Decision No. AM-6, 131, date of decision: November 12, 1971.

Description of work: Residential construction consisting of single-family homes and garden-type apartments up to and including four stories.

MODIFICATIONS

Classification	Basic hourly rates	Fringe benefits payments				
		H & W	Pensions	Vacation	App. Tr.	Other
<i>Amador County</i>						
3-California—AMA-1-2-3-m:						
Asbestos workers.....	\$8.62	\$0.60	\$0.40	\$0.90	\$0.04	
Boilermakers.....	7.20	.30	.70	.45	.02	
Boilermakers' helpers.....	6.90	.30	.70	.45	.02	
Bricklayers and stonemasons.....	7.80	.25	.15	.75		
Brick tenders.....	5.355	.245	.60	.50		
Carpenters:						
Carpenters.....	7.50	.60	.50	.50c	.02	
Hardwood floor layers; powersaw operators; saw filers, shtagiers; steel scaffold erectors and/or steel shoring erectors.....	7.65	.60	.50	.50c	.02	
Milwrights.....	7.90	.60	.50	.50c	.02	
Piledrivermen; bridge, wharf, and dock builders.....	7.63	.60	.50	.50c	.02	
Cementmasons:						
Cementmasons.....	5.94	.36	.75	.75		
Mastic; magnesite; all composition masons.....	6.19	.36	.75	.75		
Men working from swinging or slip form scaffolds.....	6.19	.36	.75	.75		
Drywall installers.....	7.25	.45	.50	.50	.04	
Electricians:						
Electricians.....	6.88	.31	1%+.55		.045	
Cable splicers.....	7.57	.31	1%+.55		.045	
Electricians (tunnel):						
Electricians.....	7.01	.31	1%+.55		.045	
Cable splicers.....	7.71	.31	1%+.55		.045	

See footnotes at end of table.

Classification	Basic hourly rates	Fringe benefits payments				
		H & W	Pensions	Vacation	App. Tr.	Other
3-California—AMA-1-2-3-m—Continued						
Elevator constructors	8.15	.185	\$0.20	2%+a		
Elevator constructors' helpers	70% J.R.	.185	.20	2%+a		
Elevator constructors' helpers (prob.)	50% J.R.					
Glaziers	\$7.00	.15	.25	8%		
Ironworkers:						
Reinforcing	7.98	.43	.425	\$0.50	.02	
Fence erectors	7.89	.43	.425	.50	.02	
Ornamental; structural	8.03	.43	.425	.50	.02	
Lathers	6.40	.195	.20			
Line construction:						
Line equipment operator	6.19	.31	1%+.55		.045	
Linemen	6.88	.31	1%+.55		.045	
Cable splicers	7.57	.31	1%+.55		.045	
Marble setters	7.59	.69	\$0.51	.53		
Painters:						
Parking lot striping work and/or highway markers	6.37	.35	.20	b		
Plasterers	6.445	.25				
Plasterers' tenders	5.75	.295	.50	.70		
Plumbers; steamfitters (northern half of county)	8.58	.65	1.05		.06	
Plumbers; steamfitters (southern half of county)	7.84	.77	.79		.03	
Roofers:						
Roofers	6.67	.48	.40			
Enameler and pitch	7.42	.48	.40			
Sheet metal workers	8.21	.36	.83		.07	
Soft floor layers (linoleum)	6.895	.405	.30	.82	.07	
Sprinkler fitters	10.55	.25	.40		.05	
Tile setters	6.60	.25		.65		
Tile setters' helpers	5.90	.22		.25		
Riggers; welders: Receive rate prescribed for craft performing operation to which rigging or welding is incidental.						
Paid holidays:						
A—New Year's Day; B—Memorial Day; C—Independence Day; D—Labor Day; E—Thanksgiving Day; F—Christmas Day.						
Footnotes:						
a. Employer contributes 4 percent basic hourly rate for 5 years' service and 2 percent basic hourly rate for 6 months to 5 years' service as Vacation Pay Credit. Six paid holidays: A through F.						
b. Employer contributes \$0.17 per hour to Holiday Fund plus \$0.10 per hour to Vacation in first years' service, \$0.20 per hour after 1 year's service but less than 5 years' service, \$0.30 per hour after 5 years' service but less than 10 years' service, and \$0.40 per hour after 10 years' service.						
c. Employer contributes \$0.35 per hour to Holiday Fund and \$0.15 per hour to Vacation Fund.						
<i>Contra Costa County</i>						
7-California—CCO-1-2-3-p:						
Asbestos workers	8.62	.60	.40	.90	.04	
Boilermakers	7.20	.30	.70	.45	.02	
Boilermakers' helpers	6.90	.30	.70	.45	.02	
Bricklayers; blocklayers; stonemasons	8.37	.40	.36	.40		
Brick tenders	6.50	.50	.50		.19	
Carpenters:						
Carpenters	7.50	.60	.50	.50g	.02	
Hardwood floor layers; powersaw operators; saw filers; shinglers; steel scaffold erectors and/or steel shoring erectors	7.65	.60	.50	.50g	.02	
Millwrights	7.90	.60	.50	.50g	.02	
Piledrivermen; bridge, wharf, and dock builders	7.63	.60	.50	.50g	.02	
Cementmasons:						
Cementmasons	5.94	.36	.75	.75		
Mastic; magnesite; all composition masons	6.19	.36	.75	.75		
Men working from swinging or slip form scaffolds	6.19	.36	.75	.75		
Drywall installers	7.25	.45	.50	.50	.04	
Electricians:						
Electricians	8.80	.40	1%+.50		.02	
Cable splicers	9.90	.40	1%+.50		.02	
Electricians (tunnel):						
Electricians	8.80	.40	1%+.50		.02	
Cable splicers	9.90	.40	1%+.50		.02	
Elevator constructors	8.15	.185	\$0.20	2%+a		
Elevator constructors' helpers	70% J.R.	.185	.20	2%+a		
Elevator constructors' helpers (prob.)	50% J.R.					
Glaziers	\$8.225	.25	.25	6%	.01	
Ironworkers:						
Reinforcing	7.98	.43	.425	\$0.50	.02	
Fence erectors	7.89	.43	.425	.50	.02	
Ornamental; structural	8.03	.43	.425	.50	.02	
Lathers	7.84	.34	.385		.025	
Line construction:						
Groundmen	6.60	.40	1%+.50		.02	
Line equipment operators	7.92	.40	1%+.50		.02	
Linemen	8.80	.40	1%+.50		.02	
Cable splicers	9.90	.40	1%+.50		.02	
Marble setters	7.59	.69	\$0.51	.53		
Painters:						
Brush	6.57	.39	.40	.80		
Spray	6.82	.39	.40	.80		
Tapers	7.07	.39	.40	.80		
Parking lot striping work and/or highway markers	6.37	.35	.20	d		
Plasterers	8.24	.575	.45		.01	
Plasterers' tenders	7.22	.50	.60		.10	
Plumbers; pipefitters	9.57	.53	1.00		.07	
Roofers:						
Journeymen	7.30	.43	.50		.01	
Mastic workers; kettlemen (2 kettles w/o pumps)	7.55	.43	.50		.01	
Journeymen roofers bitumastic, enamellers, pipewrapper, coal tar, built-up	8.30	.43	.50		.015	
Sheet metal workers	7.25	.39	.505	10%b	.05	
Soft floor layers	7.10	.38	.30	c+.28f	.02	
Sprinkler fitters	8.115	.11	.20		.005	
Steamfitters	9.415	.30	.65			
Terrazzo workers	6.94	.43	.65			
Tile setters	7.50	.49	.60		.015	
Riggers; welders: Receive rate prescribed for craft performing operation to which rigging or welding is incidental.						

Classification	Basic hourly rates	Fringe benefits payments				
		H & W	Pensions	Vacation	App. Tr.	Other
Paid holidays: A—New Year's Day; B—Memorial Day; C—Independence Day; D—Labor Day; E—Thanksgiving Day; F—Christmas Day.						
Footnotes: a. Employer contributes 4 percent of basic hourly rate for 5 years' service and 2 percent of basic hourly rate for 6 months to 5 years' service as Vacation Pay Credit. Six paid holidays: A through F. b. Four paid holidays: C, D, E, and Washington's Birthday. c. First year of employment, employer contributes \$0.14 per hour to Vacation; second through fifth year \$0.30 per hour; sixth year and thereafter \$0.46 per hour. d. Employer contributes \$0.17 per hour to Holiday Fund plus \$0.10 per hour to Vacation in first year's service, \$0.30 per hour after 1 year's service but less than 5 years' service, \$0.30 per hour after 5 years' service but less than 10 years' service, and \$0.40 per hour after 10 years' service. e. Employer contributes \$0.35 per hour to Holiday Fund and \$0.15 per hour to Vacation Fund. f. Employer contributes \$0.28 per hour to Holiday Fund. g. Employer contributes \$0.35 per hour to Holiday Fund and \$0.15 per hour to Vacation Fund.						
<i>Marin County</i>						
21—California—MARIN-1-2-3-#:						
Asbestos workers.....	8.62	.60	.40	.90	.04	
Boilermakers.....	7.20	.30	.70	.45	.02	
Boilermakers' helpers.....	6.90	.30	.70	.45	.02	
Bricklayers; stonemasons.....	8.20	.78	.58	.55		
Bricklayers hod carriers.....	6.90	.40	.30			
Carpenters:						
Carpenters.....	7.50	.60	.50	.50a	.02	
Hardwood floor layers; powersaw operators; saw filers; shinglers; steel scaffold erectors and/or steel shoring erectors.....	7.65	.60	.50	.50a	.02	
Millwrights.....	7.90	.60	.50	.50a	.02	
Piledrivermen; bridge, wharf, and dock builders.....	7.63	.60	.50	.50a	.02	
Cementmasons:						
Cementmasons.....	5.94	.36	.75	.75		
Mastic; magnesite; all composition masons.....	6.19	.36	.75	.75		
Men working from swinging or slip form scaffolds.....	6.19	.36	.75	.75		
Drywall installers.....	7.25	.45	.50	.50	.04	
Electricians:						
Cable splicers.....	7.92	.23	1% + .10		.02	
Electricians.....	7.10	.23	1% + .10		.02	
Elevator constructors.....	8.15	.185	\$0.20	2% + b		
Elevator constructors' helpers.....	70% JR	.185	.20	2% + b		
Elevator constructors' helpers (prob.).....	50% JR					
Glaziers.....	\$8.225	.25	.25	6%	.01	
Ironworkers:						
Reinforcing.....	7.98	.43	.425	\$0.50	.02	
Fence erectors.....	7.89	.43	.425	.50	.02	
Ornamental; structural.....	8.03	.43	.425	.50	.02	
Lathers.....	8.23	.46	.65	1.00	.01	
Marble setters.....	7.59	.69	.51	.53		
Painters:						
Brush.....	7.37	.39	.40			
Spray on erected steel; bridges; tanks.....	7.62	.39	.40			
Plasterers.....	7.45	.43	.25		.01	
Plasterers' tenders.....	6.70	.40	.30			
Plumbers; steamfitters.....	8.03	1.44	.765	.735	.065	
Roofers:						
Roofers; slate; tile; composition.....	7.37	.30	.55		.01	
Mastic workers; kettlemen (2 kettles without pumps).....	7.62	.30	.55		.01	
Bitumastic; enamelers; pipewrappers; coal tar.....	8.37	.30	.55		.01	
Sheet metal workers.....	8.55	.30	.44		.15	
Soft floor layers.....	7.10	.41	.30	c + 25d	.04	
Sprinkler fitters.....	8.115	.11	.20		.02	
Terrazzo workers.....	6.94	.43	.58			
Tile setters.....	7.56	.49	.60		.015	
Welders; riggers: Receive rate prescribed for craft performing operation to which rigging or welding is incidental.						
Paid holidays: A—New Year's Day; B—Memorial Day; C—Independence Day; D—Labor Day; E—Thanksgiving Day; F—Christmas Day.						
Footnotes: a. Employer contributes \$0.35 per hour to Holiday Fund and \$0.15 per hour to Vacation Fund. b. Employer contributes 4 percent of basic hourly rate for 5 years' service and 2 percent of basic hourly rate for 6 months to 5 years' service as Vacation Pay Credit. Six paid holidays: A through F. c. First year of employment, employer contributes \$0.14 per hour to Vacation; second through fifth year, \$0.285 per hour; sixth year and thereafter, \$0.46 per hour. d. Employer contributes \$0.28 per hour to Holiday Fund.						
<i>Sacramento County</i>						
24-57—California—SAC-YOL-1-2-3-q:						
Asbestos workers.....	8.62	.60	.40	.90	.04	
Boilermakers.....	7.20	.30	.70	.45	.02	
Boilermakers' helpers.....	6.90	.30	.70	.45	.02	
Bricklayers; stonemasons.....	7.73	.25	.20		1.00p/mo	
Brick tenders.....	5.355	.245	.60	.80		
Carpenters:						
Carpenters.....	7.50	.60	.50	.50d	.02	
Hardwood floor layers; powersaw operators; saw filers; shinglers; steel scaffold erectors and/or steel shoring erectors.....	7.65	.60	.50	.50d	.02	
Millwrights.....	7.90	.60	.50	.50d	.02	
Piledrivermen; bridge, wharf, and dock builders.....	7.63	.60	.50	.50d	.02	
Cementmasons:						
Cementmasons.....	5.94	.36	.75	.75		
Mastic; magnesite; all composition masons.....	6.19	.36	.75	.75		
Men working from swinging or slip form scaffolds.....	6.19	.36	.75	.75		
Drywall installers.....	7.25	.45	.60	.50	.04	
Electricians:						
Electricians.....	6.88	.31	1% & .55		.045	
Cable splicers.....	7.57	.31	1% & .55		.045	
Electricians (tunnel):						
Electricians.....	7.01	.31	1% & .55		.045	
Cable splicers.....	7.71	.31	1% & .55		.045	
Elevator constructors.....	8.15	.185	\$0.20	2% & a		
Elevator constructors' helpers.....	70% JR	.185	.20	2% & a		
Elevator constructors' helpers (prob.).....	50% JR					
Glaziers.....	\$7.605	.15	.25	8%		

Classification	Basic hourly rates	Fringe benefits payments				
		H & W	Pensions	Vacation	App. Tr.	Other
34-57-California-SAC-YOL-1-2-3-q-Continued						
Ironworkers:						
Reinforcing	7.98	.43	.425	\$0.50	.02	
Fence erectors	7.89	.43	.425	.50		
Ornamental; structural	8.03	.43	.425	.50	.02	
Lathers	8.40	.195	.20			
Line construction:						
Line equipment operators	6.19	.31	1% & .55		.045	
Linemen	6.88	.31	1% & .55		.045	
Cable splicers	7.57	.31	1% & .55		.045	
Marble setters	7.59	.60	\$0.51	.53		
Painters:						
Brush	6.57	.39	.40	.80		
Spray	6.82	.39	.40	.80		
Tapers	7.07	.39	.40	.80		
Painting lot stripping work and/or highway markers (Sacramento County only)	6.37	.35	.20	c		
Plasterers	7.65	.245	.25	.65		
Plasterers' tenders	5.75	.295	.50	.70		
Plumbers; steamfitters	8.58	.65	1.05		.06	
Roofers:						
Slate, tile; composition	6.67	.48	.40			
Enameler and pitch	7.42	.48	.40			
Felt machine operator and helpers, spudding machine operator, all types	6.92	.48	.40			
Sheet metal workers	8.21	.36	.83		.07	
Soft floor layers (linoleum)	6.895	.405	.30	.82	.07	
Sprinkler fitters	10.55	.25	.40		.05	
Terrazzo workers	7.73	.25	.20		1.00p/mo	
Tile setters	6.40	.42	.35	.80	b	
Tile setters' helpers	5.00	.22		.26		
Riggers; welders: Receive rate prescribed for craft performing operation to which rigging or welding is incidental.						
Paid holidays:						
A—New Year's Day; B—Memorial Day; C—Independence Day; D—Labor Day; E—Thanksgiving Day; F—Christmas Day.						
Footnotes:						
a. Employer contributes 4 percent of basic hourly rate for 5 years' service and 2 percent of basic hourly rate for 6 months to 5 years' service as Vacation Pay Credit. Six paid holidays: A through F.						
b. Employer contributes \$2 per month per apprentice employed.						
c. Employer contributes \$0.17 per hour to Holiday Fund plus \$0.10 per hour to Vacation in first year's service, \$0.20 per hour after 1 year's service but less than 5 years' service, \$0.30 per hour after 5 years' service but less than 10 years' service, and \$0.40 per hour after 10 years' service.						
d. Employer contributes \$0.25 per hour to Holiday Fund and \$0.15 per hour to Vacation Fund.						
38-California-SFR-1-2-3-r: San Francisco County						
Asbestos workers						
Asbestos workers	8.62	.60	.40	.90	.04	
Boilermakers	7.20	.30	.70	.45	.02	
Boilermakers' helpers	6.90	.30	.70	.45	.02	
Bricklayers; stonemasons	8.20	.78	.58	.55		
Brick hod carriers	7.05	.25	.40	.60		
Carpenters:						
Carpenters	7.50	.60	.50	.50d	.02	
Hardwood floor layers; powersaw operators; saw filers; shinglers; steel scaffold erectors and/or steel shoring erectors	7.65	.60	.50	.50d	.02	
Millwrights	7.90	.60	.50	.50d	.02	
Piledrivermen; bridges, wharf, and dock builders	7.63	.60	.50	.50d	.03	
Cementmasons:						
Cementmasons	5.94	.36	.75	.75		
Mastic; magnesite; all composition masons	6.19	.36	.75	.75		
Men working from swinging or slip form scaffolds	6.19	.36	.75	.75		
Drywall installers	7.25	.45	.50	.50	.04	
Electricians:						
Electricians	7.975	.395	1%+.35		.04	
Cable splicers	8.97	.395	1%+.35		.04	
Electricians (tunnel):						
Electricians	7.975	.395	1%+.35		.04	
Cable splicers	8.97	.395	1%+.35		.04	
Elevator constructors	8.15	.185	\$0.20	2%+a		
Elevator constructors' helpers	70%JR	.185	.30	2%+a		
Elevator constructors' helpers (prob.)	50%JR					
Glaziers	\$8.225	.25	.25	.6%	.01	
Ironworkers:						
Reinforcing	7.98	.43	.425	\$0.50	.02	
Fence erectors	7.89	.43	.425	.50	.02	
Ornamental; structural	8.03	.43	.425	.50	.02	
Lathers	8.23	.46	.65	1.00	.01	
Line construction:						
Groundmen	6.78	.395	1%+.35		.04	
Linemen	7.975	.395	1%+.35		.04	
Cable splicers	8.97	.395	1%+.35		.04	
Marble setters	7.59	.69	\$0.51	.53		
Painters:						
Brush	7.37	.39	.40			
Spray	7.62	.39	.40			
Plasterers	7.77	.33	.21			
Plasterers' tenders	7.00	.25	.40	.95		
Plumbers; steamfitters	8.03	1.44	.705	.735	.065	
Roofers:						
Roofers; slate, tile; composition; and built-up	\$7.26	.35	.60		.01	
Mastic workers and kettleman (2 kettles) without pumps	7.51	.35	.60		.01	
Bitumastic; enameler; pipewrappers; coal tar	8.26	.35	.60		.01	
Extra men helpers	70%JR					
Sheet metal workers	\$7.78	.38	.45		.005	
Soft floor layers (linoleum)	7.10	.41	.30	b+.28c	.04	
Sprinkler fitters	8.115	.11	.20		.02	
Terrazzo workers	6.94	.43	.65			
Tile setters	7.56	.49	.60		.015	
Riggers; welders: Receive rate prescribed for craft performing operation to which rigging or welding is incidental.						
Paid holidays:						
A—New Year's Day; B—Memorial Day; C—Independence Day; D—Labor Day; E—Thanksgiving Day; F—Christmas Day.						
Footnotes:						
a. Employer contributes 4 percent of basic hourly rate for 5 years' service and 2 percent of basic hourly rate for 6 months to 5 years' service as Vacation Pay Credit. Six paid holidays: A through F.						
b. First year of employment, employer contributes \$0.14 per hour to Vacation Fund; second through fifth year, \$0.25 per hour; sixth year and thereafter \$0.46 per hour.						
c. Employer contributes \$0.28 per hour to Holiday Fund.						
d. Employer contributes \$0.35 per hour to Holiday Fund and \$0.15 per hour to Vacation Fund.						
e. Eight paid holidays: A through F, Washington's Birthday and Admission Day.						

Classification	Basic hourly rates	Fringe benefits payments				
		H & W	Pensions	Vacation	App. Tr.	Other
<i>San Joaquin County</i>						
6-59-California-SJO-1-2-3-w:						
Asbestos workers	8.62	.60	.40	.90	.04	
Boilermakers	7.20	.30	.70	.45	.02	
Boilermakers' helpers	6.90	.30	.70	.45	.02	
Bricklayers; block layers; Stonemasons	7.80	.25	.15	.75		
Brick tenders	5.20	.50	.60	.60		
Carpenters:						
Carpenters	7.50	.60	.50	.50c	.02	
Hardwood floor layers; powersaw operators; saw filers; shinglers; steel scaffold erectors and/or steel shoring erectors	7.65	.60	.80	.50c	.02	
Millwrights	7.90	.60	.50	.50c	.02	
Piledrivers; bridge, wharf and dock builders	7.63	.60	.50	.50c	.02	
Cementmasons:						
Cementmasons	5.94	.36	.75	.75		
Mastic; magnesite; all composition	6.19	.36	.75	.75		
Swinging or slip form scaffolds	6.19	.36	.75	.75		
Drywall installers	7.25	.45	.50	.50	.04	
Electricians:						
Electricians; technicians	7.21	.26	1%		.01	
Cable splicers	8.11	.26	1%		.01	
Elevator constructors	8.15	.185	\$0.20	2%+a		
Elevator constructors' helpers	70% J.R.	.185	.20	2%+a		
Elevator constructors' helpers (prob.)	50% J.R.					
Glaziers	\$7.605	.15	.25	8%		
Ironworkers:						
Reinforcing	7.98	.43	.425	\$0.50	.02	
Fence erectors	7.80	.43	.425	.50	.02	
Ornamental; structural	8.03	.43	.425	.50	.02	
Lathers	7.20	.25	.20	.80		
Line construction:						
Linemen	6.61	.23	1%		.01	
Cable splicers	7.44	.23	1%		.01	
Marble setters	7.59	.69	\$0.61	.53		
Painters:						
Parking lot striping work and/or highway markers	6.37	.35	.20	b		
Plasters	6.445	.25				
Plasters' tenders	5.525	.50	.60			
Plumbers; steamfitters	7.54	.77	.79		.03	
Roofers:						
Composition; slate; tile; built-up	6.64	.45	.20	.75		
Sheet metal workers	6.375	.36	.50	1.00		
Soft floor layers (carpet, linoleum, and soft tile)	6.895	.405	.30	.82	.07	
Sprinkler fitters	10.55	.25	.40		.05	
Tile setters	6.60	.25		.65		
Tile setters' helpers	5.00	.22		.20		
Riggers; welders: Receive rate prescribed for craft performing operation to which welding is incidental.						
Paid holidays: A—New Year's Day; B—Memorial Day; C—Independence Day; D—Labor Day; E—Thanksgiving Day; F—Christmas Day.						
Footnotes: a. Employer contributes 4 percent of basic hourly rate for 5 years' service and 2 percent of basic hourly rate for 6 months to 5 years' service as Vacation Pay Credit. Six paid holidays: A through F. b. Employer contributes \$0.17 per hour to Holiday Fund plus \$0.10 per hour to Vacation in first year's service, \$0.20 per hour after 1 year's service but less than 5 years' service, \$0.30 per hour after 5 years' service but less than 10 years' service, and \$0.40 per hour after 10 years' service. c. Employer contributes \$0.35 per hour to Holiday Fund and \$0.15 per hour to Vacation Fund.						
<i>Santa Clara County</i>						
M-45-California-SBEN-SCL-1-2-3-4:						
Asbestos workers	8.62	.60	.40	.90	.04	
Boilermakers	7.20	.30	.70	.45	.02	
Boilermakers' helpers	6.90	.30	.70	.45	.02	
Bricklayers; cement block layers; stonemasons	7.45	.54	.50	.50	.01	
Brick tenders	6.58	.45	.40			
Carpenters:						
Carpenters	7.50	.60	.50	.50c	.02	
Hardwood floor layers; Powersaw operators; saw filers; shinglers; steel scaffold erectors and/or steel shoring erectors	7.65	.60	.50	.50c	.02	
Millwrights	7.90	.60	.50	.50c	.02	
Piledrivers; bridge, wharf, and dock builders	7.63	.60	.50	.50c	.02	
Cementmasons:						
Cementmasons	5.94	.36	.75	.75		
Mastic; magnesite; all composition masons	6.19	.36	.75	.75		
Men working from swinging or slip form scaffolds	6.19	.36	.75	.75		
Drywall installers	7.25	.45	.50	.50	.04	
Electricians:						
Electricians	8.72	.45	1%			
Cable splicers	9.81	.45	1%			
Electricians (tunnel or shaft):						
Electricians	8.59	.38	1%			
Cable splicers	9.66	.38	1%			
Elevator constructors	8.15	.185	\$0.20	2%+a		
Elevator constructors' helpers	70% J.R.	.185	.20	2%+a		
Elevator constructors' helpers (prob.)	50% J.R.					
Glaziers	\$8.225	.25	.25	6%	.01	
Ironworkers:						
Reinforcing	7.98	.43	.425	\$0.50	.02	
Fence erectors	7.80	.43	.425	.50	.02	
Ornamental; structural	8.03	.43	.425	.50	.02	
Lathers	7.73	.30	.25			
Line construction:						
Linemen	6.41	.15	1%			
Cable splicers	7.21	.15	1%			
Marble setters	7.59	.69	\$0.61	.53		
Painters:						
Brush	7.37	.39	.40			
Spray on erected steel bridge, tanks	7.62	.39	.40			
Parking lot striping work and/or highway markers	6.37	.35	.20	b		
Plasterers	6.56	.46	.40	.70	.01	
Plasterers' tenders	6.95	.40	.15			
Plumbers; steamfitters	8.83	.46	.65		.08	

Classification	Basic hourly rates	Fringe benefits payments				
		H & W	Pensions	Vacation	App. Tr.	Other
35-33-California—SBEN-SCL-1-2-3-4—Continued						
Roofers:						
Roofers; kettlemen (1 kettle)	6.71	.36	.53	1.00		
Coal tar, bitumastic enamelers; mastic workers; kettlemen (2 kettles) pitch	7.21	.36	.53	1.00		
Soft floor layers (linoleum)	7.19	.35	.30	.55	.05	
Sprinkler fitters (San Benito County)	10.55	.25	.40		.05	
Sprinkler fitters (Santa Clara County)	8.115	.11	.20		.02	
Terrazzo workers	7.45	.54	.50	.50	.01	
Tile setters	7.56	.49	.60		.015	
Riggers; welders: Receive rate prescribed for craft performing operation to which rigging or welding is incidental.						
Paid holidays:						
A—New Year's Day; B—Memorial Day; C—Independence Day; D—Labor Day; E—Thanksgiving Day; F—Christmas Day.						
Footnotes:						
a. Employer contributes 4 percent of basic hourly rate for 5 years' service and 2 percent of basic hourly rate for 6 months to 5 years' service as Vacation Pay Credit. Six paid holidays: A through F.						
b. Employer contributes \$0.17 per hour to Holiday Fund plus \$0.10 per hour to Vacation in first year's service, \$0.20 per hour after 1 year's service but less than 5 years' service, \$0.30 per hour after 5 years' service but less than 10 years' service, and \$0.40 per hour after 10 years' service.						
c. Employer contributes \$0.35 per hour to Holiday Fund and \$0.15 per hour to Vacation Fund.						
<i>Solano County</i>						
48-California—SOL-1-2-3-p:						
Asbestos workers	8.02	.60	.40	.90	.04	
Boilermakers	7.20	.30	.70	.45	.02	
Boilermakers' helpers	6.90	.30	.70	.45	.02	
Bricklayers; stonemasons	8.20	.78	.55	.55		
Brick tenders	5.55	.50	.60	.60		
Carpenters:						
Carpenters	7.50	.60	.50	.50e	.02	
Hardwood floor layers; powersaw operators; saw filers; shinglers; steel scaffold erectors and/or steel shoring erectors	7.65	.60	.50	.50e	.02	
Millwrights	7.90	.60	.50	.50e	.02	
Piledrivermen; bridge, wharf, and dock builders	7.63	.60	.50	.50e	.02	
Cementmasons:						
Cementmasons	5.94	.36	.75	.75		
Mastic; magnesite; all composition	6.19	.36	.75	.75		
Swinging or slip form scaffolds	6.19	.36	.75	.75		
Drywall installers	7.25	.45	.50	.50	.04	
Electricians:						
Electricians; technicians	8.43	.35	1%+25		.02	
Cable splicers	8.03	.35	1%+25		.02	
Elevator constructors	8.15	.185	.20	2%+a		
Elevator constructors' helpers	70%JR	.185	.20	2%+a		
Elevator constructors' helpers (prob.)	50%JR					
Glassers (southwestern part of county)	\$8.225	.25	.25	0%	.01	
Ironworkers:						
Reinforcing	7.98	.43	.425	\$0.50	.02	
Fence erectors	7.89	.43	.425	.50	.02	
Ornamental; structural	8.03	.43	.425	.50	.02	
Line construction:						
Groundmen	6.32	.35	1%+25		.02	
Line equipment operators	7.59	.35	1%+25		.02	
Linemen	8.43	.35	1%+25		.02	
Cable splicers	8.93	.35	1%+25		.02	
Marble setters	7.59	.69	\$0.51	.53		
Painters:						
Brush	6.57	.39	.40	.80		
Sperry	6.82	.39	.40	.80		
Tapers	7.07	.39	.40	.80		
Parking lot striping work and/or highway markers	6.37	.35	.20	c		
Plasterers	7.45	.43	.25		.01	
Plasterers' tenders	5.55	.50	.60	.60		
Plumbers; steamfitters	8.50	.35	.58		.07	
Roofers	6.45	.20	.40	.35		
Sheet metal workers	8.55	.36	.44		.15	
Soft floor layers	7.10	.36	.30	b+.28d	.05	
Sprinkler fitters	8.115	.11	.20		.02	
Terrazzo workers	6.94	.43	.58			
Tile setters	7.56	.49	.60		.015	
Riggers; welders: Receive rate prescribed for craft performing operation to which rigging or welding is incidental.						
Paid holidays:						
A—New Year's Day; B—Memorial Day; C—Independence Day; D—Labor Day; E—Thanksgiving Day; F—Christmas Day.						
Footnotes:						
a. Employer contributes 4 percent of basic hourly rate for 5 years' service and 2 percent of basic hourly rate for 6 months to 5 years' service as Vacation Pay Credit. Six Paid holidays: A through F.						
b. First year of employment employer contributes \$0.14 per hour to Vacation; second through fifth year \$0.30 per hour; sixth year and thereafter \$0.40 per hour.						
c. Employer contributes \$0.17 per hour to Holiday Fund plus \$0.10 per hour to Vacation in first year of service, \$0.20 per hour after 1 year's service but less than 5 years' service; \$0.30 per hour after 5 years' service but less than 10 years' service, \$0.40 per hour after 10 years' service.						
d. Employer contributes \$0.28 per hour to Holiday Fund.						
e. Employer contributes \$0.35 per hour to Holiday Fund and \$0.15 per hour to Vacation Fund.						
<i>Sonoma County</i>						
49-California—SON-1-2-3-r:						
Asbestos workers	8.62	.60	.40	.90	.04	
Boilermakers	7.20	.30	.70	.45	.02	
Boilermakers' helpers	6.90	.30	.70	.45	.02	
Bricklayers; stonemasons	8.20	.78	.58	.55		
Brick hod carriers	5.44	.40	.50	.50		
Carpenters:						
Carpenters	7.50	.60	.50	.50d	.02	
Hardwood floor layers; powersaw operators; saw filers; shinglers; steel scaffold erectors and/or steel shoring erectors	7.65	.60	.50	.50d	.02	
Millwrights	7.90	.60	.50	.50d	.02	
Piledrivermen; bridge, wharf and dock builders	7.63	.60	.50	.50d	.02	
Cementmasons:						
Cementmasons	5.94	.36	.75	.75		
Mastic; magnesite; all composition	6.19	.36	.75	.75		
Swinging or slip form scaffolds	6.19	.36	.75	.75		
Drywall installers	7.25	.45	.50	.50	.04	

Classification	Basic hourly rates	Fringe benefits payments				
		H & W	Pensions	Vacation	App. Tr.	Other
49-California—SON-1-2-3-r—Continued						
Electricians:						
Electricians.....	7.10	.23	1% + .10			.02
Cable splicers.....	7.92	.23	1% + .10			.02
Elevator constructors.....	8.15	.185	\$0.20	2% + a		
Elevator constructors' helpers.....	70% J.R.	.185	.20	2% + a		
Elevator constructors' helpers (prob.).....	50% J.R.					
Glaziers.....	\$8.225	.25	.25	6%		.01
Ironworkers:						
Reinforcing.....	7.98	.43	.425	\$0.50		.02
Fence erectors.....	7.89	.43	.425	.50		.02
Ornamental; structural.....	8.03	.43	.425	.50		.02
Lathers.....	5.35	.25	.40	.50		
Marble setters.....	7.59	.69	.51	.53		
Painters:						
Brush.....	7.37	.39	.40			
Spray.....	7.62	.39	.40			
Plasterers.....	7.45	.43	.25			.01
Plumbers; fitters.....	5.44	.40	.50	.50		
Roofers; slate; tile.....	8.03	1.44	.705	.735		.065
Roofers; bitumastic, enamels, pipewrappers, coal tar, pitch, built-up.....	7.34	.38	.50			.01
Roofers, mastic workers; kettlemen (2 kettles without pumps).....	8.34	.38	.50			.01
Roofers, mastic workers; kettlemen (2 kettles without pumps).....	7.59	.38	.50			.01
Sheet metal workers.....	8.55	.36	.44			.15
Soft floor layers.....	7.10	.41	.30	b + 25c		.04
Sprinkler fitters.....	8.115	.11	.20			.02
Terrazzo workers.....	6.94	.43	.58			
Tile setters.....	7.55	.49	.60			.015

Welders: Receive rate prescribed for craft performing operation to which welding is incidental.

Paid holidays:
 A—New Year's Day; B—Memorial Day; C—Independence Day; D—Labor Day; E—Thanksgiving Day; F—Christmas Day.

Footnotes:
 a. Employer contributes 4 percent of basic hourly rate for 5 years' service and 2 percent of basic hourly rate for 6 months to 5 years' service as Vacation Pay Credit. Six paid holidays: A through F.
 b. First year of employment, employer contributes \$0.14 per hour to Vacation; second through fifth years, \$0.295 per hour; sixth year and thereafter \$0.40 per hour.
 c. Employer contributes \$0.28 per hour to Holiday Fund.
 d. Employer contributes \$0.35 per hour to Holiday Fund and \$0.15 per hour to Vacation Fund.

1-California—NCAL-LAB-1-2-3-t					
Laborers:					
Bridge; brush loaders and piler; cleanup; dumpman; general; landscape; limbers toolroom attendant.....	5.185	.50	.80	.60	.04
Asphalt shovelers; cement dumper; chipper; choker setter and rigger; chucktender; concrete; guinea chaser; high pressure nozzleman-hydraulic monitor; nipper; pneumatic-gas-electric tool operator (not otherwise classified); sloper; loading, unloading, handling materials for reinforcing concrete construction.....	5.285	.50	.80	.60	.04
Aligners; asphalt ironers and rakers; bucket; buggy/mobile; chain saw; compactors; concrete saw and pan work; cribber and/or shoring; curb setter; form raiser; faller; headerboard man; post hole digger (air-gas-electric); jack-hammer; kettlemaster; log loader; magnesite and mastic workers; pavement breaker pipelayer; pipewrapper; power broom sweeper; riprap stonepaver and rock slinger; rotary scarifier; roto-filler; sandblaster; barko, wackers, and similar type tampers; tank cleaners; tree climber; vibrator; vibra-screed bull float.....	5.435	.50	.80	.60	.04
Burning and welding.....	5.485	.50	.80	.60	.04
Pipelayers; caulkers; banders (Contra Costa County only).....	5.635	.50	.80	.60	.04
Blasters; drills (diamond-wagon); high scaler; powderman; tree topper.....	5.66	.50	.80	.60	.04
Laborers on general construction work on or in bell hole footings and shaft.....	5.985	.50	.80	.60	.04
Gunite Laborers:					
Nozzleman; rodman; gunman; groundman.....	5.895	.50	.80	.60	.04
Reboundman.....	5.305	.50	.80	.60	.04

1-California—NCAL-PEO-1-2-3-e					
Power equipment operators:					
Operator of helicopter (when used in erection work); remote controlled earthmoving equipment.....	8.80	.475	.65	.50	.14
Loader (over 18 cu. yds.).....	8.60	.475	.65	.50	.14
Loader (over 12 cu. yds. up to and including 18 cu. yds.); rubber-tired multipurpose earthmoving machines (2 units) (over 75 cu. yds. "struck" m.r.c.); power shovels and draglines (over 7 cu. yds. m.r.c.); band wagons (in conjunction with wheel excavator); (over 750 cu. yds. per hour).....	8.41	.475	.65	.50	.14
Automatic concrete slip form paver; automatic railroad car dumper; canal finger drain in backfiller; canal trimmer; rubber-tired earthmoving machines (multiple propulsion power units and two or more scrapers) up to and including 75 cu. yds. "struck" m.r.c.; highline cableway (over 5 tons); loader (over 4 yds., up to and including 12 cu. yds.); power shovels, clamshells, draglines, backhoes, gradalls (over 1 yd. up to and including 7 cu. yds. m.r.c.); self-propelled compactor (with multiple propulsion power units); slip form paver (concrete or asphalt); tandem cats; trencher (pulling attached shield); tower cranes mobile; single engine rubber-tired earthmoving machine (with tandem scrapers); cranes (over 25 tons); Universal Liebherr and tower cranes (and similar types); wheel excavator (up to and including 750 cu. yds. per hour); Whirley crane (over 25 tons).....	7.65	.475	.65	.50	.14
Cranes (not over 25 tons, hammerhead and gantry); power shovels, clamshells, draglines, backhoes, gradalls (up to and including 1 cu. yd. m.r.c.); power blade.....	7.54	.475	.65	.50	.14
Boom-type backfilling machine; bridge crane; Carry-lift (or similar); chemical grouting machine; chief of party; combination backhoe and loader (up to and including 3 1/2 yds.); derricks (2 operators required when swing engine remote from hoist); derrick barges (except excavation work); Do-more loader and Adams Elegrader; elevating grader operator; Euclid loader and similar types; rubber-tired scraper, self-loading (paddle wheels, etc.); heavy-duty rotary drills rigs (including caisson foundation work and Robbins-type drills); Koehring skoooper (or similar); lift slab machine (Vagborg and similar types); loader (2 yds. up to and including 4 yds.); locomotive (over 100 tons) (single or multiple units); multiple engine earthmoving machine (euclids, dozers, etc.) (no tandem scraper); prestress wire wrapping machine; shuttle car (reclaim station); soil stabilizer (P & H or equal); subgrader (gurrries or other automatic type); track laying type, earthmoving machine (single engine with tandem scrapers); tractor, compressor drill comb; train loading station; vacuum cooling plant; single engine scraper over 45 yds; whirley crane (up to and including 25 tons).....	7.40	.475	.65	.50	.14
Canal finger drain digger; Chicago boom; combination mixer and compressor (gunite); combination slurry mixer and/or cleaner; highline cableway (5 tons and under); lull hi-lift or similar (20 ft. or over); mucking machine; tractor (with boom) (D-6 or larger and similar).....	7.32	4.75	.65	.50	.14

Classification	Base hourly rates	Fringe benefits payments				
		H & W	Pensions	Vacation	App. Tr.	Other
1-California-NAC-PEO-1-2-3-e-Continued						
Power equipment operators-Continued						
Armco-coater (or similar); asphalt plant engineer; cast-in-place pipelaying machine; combination slusher and motor operator; concrete batch plant (multiple units); dozer; heavy-duty repairman and/or welder; Ken seal machine (or similar); Kolman loader; loader (up to 2 yds.); mechanical shield operator (or similar); mechanical trench shield; portable crushing and screening plants; push cat; rubber-tired earthmoving equipment (up to and including 45 cu. yds. "struck" m.r.c., euclids, T pulls, DW-10, 20, 21, and similar; tractor-drawn scraper; self-propelled compactor with dozer; sheepfoot; tractor; trenching machine; tribatch paver; tunnel mole boring machine operator; welder; woods mixer (and other similar pugmill equipment)	7.16	.475	.65	.50	.14	
Concrete conveyor or concrete pump, truck or equipment mounted (boom length to apply); concrete conveyor, building site; deck engineers; dual drum mixer; Fuller Kenyon pump and similar types; instrumentman; material hoist (2 or more drums); mechanical finishers or spreader machine (asphalt, Barber-Greene and similar); mine or shaft hoist; mixer-mobile; pavement breaker with or without compressor combination; pavement breaker, truck mounted with compressor combination; pipe bending machine (pipelines only); pipe cleaning machine (tractor propelled and supported); pipewrapping machine (tractor propelled and supported); refrigeration plant; self-propelled boom-type lifting device; self-propelled elevating grade plane; slusher operator; small tractor (with boom); soil tester; truck-type loader	6.88	.475	.65	.50	.14	
BLH Lima road pactor or similar; boom truck or dual purpose A-frame truck; concrete batch plants (wet or dry); concrete saws (self-propelled unit) on streets, highways, airports, and canals; drilling and boring machinery, vertical and horizontal (not to apply to waterliners, wagon drills or jackhammers); gradesetter, grade checker (mechanical or otherwise); highline cableway signalman; locomotives (steam or over 30 tons) Magnums internal full slab vibrator (on airports, highways, canals, and warehouses); mechanical finishers (concrete) (Clary, Johnson, Bidwell Bridge Deck or similar types); mechanical brum, curb and/or curb and gutter machine, concrete or asphalt; portable crushers; power jumbo operator (setting slip forms, etc., in tunnels); roller; screedman (Barber-Greene and similar) (asphaltic concrete paving); self-propelled compactor (single engine); self-propelled pipeline wrapping machine (Per suit, CRC, or similar types); slip form pumps (power-driven hydraulic lifting device for concrete forms); small rubber-tired tractors; surface heater	6.78	.475	.65	.50	.14	
Compressor operator (2 to 7) (electric, diesel, or gas powered); concrete mixers (over 1 yd.); concrete pumps or pumpecrete guns; generators, gasoline, diesel or electric drive (100 kw.); press-weld (air-operated); pumps (2 to 7); welding machines (gasoline or diesel) (2 to 7)	6.68	.475	.65	.50	.14	
Ballast jack tamper; ballast regulator; ballast tamper multipurpose; boxman (asphalt plant); forklift or lumber stacker (construction job site); line master; lubrication and service engineer (mobile and grease rack); material hoist (1-drum); shuttlecar; the spacer; towmobile	6.53	.475	.65	.50	.14	
Box operator (bunker); locomotive; motorman; oiler; rodman or chalmun; ross carrier (construction jobsite); rotomist operator; screedman (except asphaltic concrete paving); self-propelled, automatically applied concrete curing machine (on streets, highways, airports and canals); trenching machine (maximum digging capacity 3 ft. depth); tigger hoist, single drum	6.13	.475	.65	.50	.14	
Compressor operator, electrically diesel or gas powered, etc.; concrete mixer (up to and including 1 yd.); conveyor belt operator (tunnel); fireman hot plant; hydraulic monitor; mechanical conveyor (handling building materials); mixer box operator (concrete plant); pump operator; spreader boxman (with screeds); tar pot fireman (power agitated)	5.90	.475	.65	.50	.14	
Assistants to engineers (brakeman; fireman; heavy-duty repairman helper; oiler; deckhand; signalman; switchman; tar pot fireman); partsman (heavy-duty repair shop parts room)	5.75	.475	.65	.50	.14	
1-California-NCAL-TD-1-2-3-1:						
Truckdrivers:						
Bulk cement spreader (w/wo auger, over 80 yds. and including 95 yds. water level); dump (over 80 yds. and including 95 yds. water level); dumperete truck (over 80 yds. and including 95 yds. water level); dumpster (over 80 yds. and including 95 yds. water level); skid truck (debris box over 80 yds. and including 95 yds. water level); trucks (dry prebatch concrete mix, over 80 yds. and including 95 yds. water level)	7.01	.565	.40	.65		
Bulk cement spreader (w/wo auger, over 65 yds. and including 80 yds. water level); dump (65 yds. and including 80 yds. water level); dumperete truck (65 yds. and including 80 yds. water level); dumpster (65 yds. and including 80 yds. water level); skid truck (debris box, 65 yds. and including 80 yds. water level); trucks (dry prebatch concrete mix, 65 yds. and including 80 yds. water level)	6.86	.565	.40	.65		
Bulk cement spreader (w/wo auger, over 50 yds. and under 65 yds. water level); dump (over 50 yds. and under 65 yds. water level); dumperete truck (over 50 yds. and under 65 yds. water level); dumpster (over 50 yds. and under 65 yds. water level); helicopter pilot (when transporting men or materials); skid truck (debris box, over 50 yds. and under 65 yds. water level); trucks (dry prebatch concrete mix, over 50 yds. and under 65 yds. water level)	6.71	.565	.40	.65		
Bulk cement spreader (w/wo auger, over 35 yds. and including 50 yds. water level); dump (over 35 yds. and including 50 yds. water level); dumperete truck (over 35 yds. and including 50 yds. water level); dumpster (over 35 yds. and including 50 yds. water level); skid truck (debris box, over 35 yds. and including 50 yds. water level); trucks (dry prebatch concrete mix, over 35 yds. and including 50 yds. water level)	6.56	.565	.40	.65		
Bulk cement spreader (w/wo auger, over 24 yds. and including 35 yds. water level); dump (over 24 yds. and including 35 yds. water level); dumperete truck (over 24 yds. and including 35 yds. water level); dumpster (over 24 yds. and including 35 yds. water level); DW 10's, 20's, 21's, and other similar cat-type, Terra Cobra, LeTourneau Pulls, Tournooeker, Euclid, and similar type equipment when pulling Aqua/Pak, water tank trailers and fuel and/or grease tank trailers or other miscellaneous trailers; skid truck (debris box, over 24 yds. and including 35 yds. water level); trucks (dry prebatch concrete mix, over 24 yds. and including 35 yds. water level)	6.41	.565	.40	.65		
Bulk cement spreader (w/wo auger, over 18 yds. and including 24 yds. water level); combination dump truck and dump trailer; dump (over 18 yds. and including 24 yds. water level); dumperete truck (over 18 yds. and including 24 yds. water level); dumpster (over 18 yds. and including 24 yds. water level); skid truck (debris box, over 18 yds. and including 24 yds. water level); transit mix, agitator (over 14 yds. through 16 yds.); trucks (dry prebatch concrete mix, over 18 yds. and including 24 yds. water level)	6.355	.565	.40	.65		
Truck repairman	6.345	.565	.40	.65		
P. B. or similar type self-loading truck	6.31	.565	.40	.65		
Bulk cement spreader (w/wo auger, over 12 yds. and including 18 yds. water level); dump (over 12 yds. and including 18 yds. water level); dumperete truck (over 12 yds. and including 18 yds. water level); dumpster (over 12 yds. and including 18 yds. water level); skid truck (debris box, over 12 yds. and including 18 yds. water level); trucks (dry prebatch concrete mix, over 12 yds. and including 18 yds. water level)	6.25	.565	.40	.65		
Transit mix, agitator (over 12 yds. through 14 yds.)	6.225	.565	.40	.65		
Bulk cement spreader (w/wo augers, 8 yds. and including 12 yds. water level); dump (8 yds. and including 12 yds. water level); dumperete (8 yds. and including 12 yds. water level); dumpster (8 yds. and including 12 yds. water level); self-propelled street sweeper with self-contained refuse bin; skid truck (debris box, 8 yds. and including 12 yds. water level); snowgo and/or snowplow; trucks (dry prebatch concrete mix, 8 yds. and including 12 yds. water level)	6.21	.565	.40	.65		
Transit mix, agitator (over 10 yds. through 12 yds.)	6.125	.565	.40	.65		
Heavy-duty transport (gooseneck low bed)	6.22	.565	.40	.65		
Jetting truck and water truck (5,000 and under 7,000 gals.)	6.085	.565	.40	.65		
Vacuum truck (5,000 gals. and under 7,500 gals.)	6.035	.565	.40	.65		
Transit mix, agitator (8 yds. through 10 yds.)	6.025	.565	.40	.65		
Ross hyster, similar straddle carrier	6.015	.565	.40	.65		
Heavy-duty transport (high bed)	5.99	.565	.40	.65		
"A" frame drivers, winch truck; buggy/mobile; hydrolift, Swedish crane-type (including when Swedish crane is used for jetting); jetting truck and water truck (4,000 and under 5,000 gals.); rubber-tired truck jumbo	5.985	.565	.40	.65		

Classification	Basic hourly rates	Fringe benefits payments				
		H & W	Pensions	Vacation	App. Tr.	Other
1-California—NCAL—TD—1-2-3-f—Continued						
Truckdrivers—Continued						
Bulk cement spreader (w/wo augers, 6 yds. and under 8 yds. water level); dump (6 yds. and under 8 yds. water level); dumpcrete truck (6 yds. and under 8 yds. water level); dumpster (6 yds. and under 8 yds. water level); skid truck (debris box, 6 yds. and under 8 yds. water level); trucks (dry prebatch concrete mix, 6 yds. and under 8 yds. water level)	5.97	.565	.40	.65		
Rubber-tired muck car (not self-loaded)	5.945	.565	.40	.65		
Vacuum truck (3,500 gals. and under 5,500 gals.)	5.935	.565	.40	.65		
Combination winch truck with hoist-transit mix, agitator (6 yds. and under 8 yds.)	5.925	.565	.40	.65		
Jetting truck and water truck (2,500 gals. under 4,000 gals.)	5.885	.565	.40	.65		
Seissor truck; single unit flat rack (3-axle unit, industrial lift truck, mechanical tailgate); small rubber-tired tractor (when used within teamsters jurisdiction)	5.87	.565	.40	.65		
Vacuum truck (under 3,500 gals.)	5.855	.565	.40	.65		
Truck repairman helper	5.845	.565	.40	.65		
Transit mix, agitator (under 6 yds.)	5.825	.565	.40	.65		
Lift jitneys, forklift	5.805	.565	.40	.65		
Jetting truck and water truck (under 2,500 gals.)	5.785	.565	.40	.65		
Bulk cement spreader (w/wo auger, 4 yds. and under 6 yds. water level); dump (4 yds. and under 6 yds. water level); dumpcrete truck (4 yds. and under 6 yds. water level); dumpster (4 yds. and under 6 yds. water level); skid truck (debris box, 4 yds. and under 6 yds. water level); single unit flat rack (2-axle unit, industrial lift truck, mechanical tailgate); trucks (dry prebatch concrete mix, 4 yds. and under 6 yds. water level)	5.77	.565	.40	.65		
Bulk cement spreader (w/wo auger, under 4 yds. water level); bus or manual driver; concrete pump machine; concrete pump truck (when flat rack truck is used appropriate flat rack rate shall apply); dump (under 4 yds. water level); dumpcrete truck (under 4 yds. water level); dumpster (under 4 yds. water level); escort or pilot car driver; nipper truck (when flat rack truck is used appropriate flat rack rate shall apply); pickup trucks; skid trucks (debris box, under 4 yds. water level); team drivers; trucks (dry prebatch concrete mix, under 4 yds. water level); vacuum truck helpers; warehousemen	5.675	.565	.40	.65		

State: California; County: Los Angeles; Decision No. AM-6, 142, date of decision: November 12, 1971.

Description of work: Residential construction consisting of single family homes and garden-type apartments up to and including four stories.

MODIFICATIONS

10-California—LAN—1-2-3-p:

Classification	Basic hourly rates	Fringe benefits payments				
		H & W	Pensions	Vacation	App. Tr.	Other
<i>Los Angeles County</i>						
Asbestos workers	\$9.77	\$0.45	\$0.35		\$0.025	
Boilermakers	7.20	.30	.70	\$0.45	.02	
Boilermakers' helpers	6.90	.30	.70	.45	.02	
Bricklayers; stonemasons; tuckpointers	7.20	.40	.40	.30	.65	
Brick tenders	5.85	.45	.85	.30		
Carpenters:						
Carpenters	6.33	.61	.75	.50	.01	
Saw filers	6.41	.61	.75	.50	.01	
Table powersaw operators	6.43	.61	.75	.50	.01	
Shinglers	6.46	.61	.75	.50	.01	
Hardwood floor layers; millwrights	6.63	.61	.75	.50	.01	
Pneumatic nailer	6.88	.61	.75	.50	.01	
Piledrivermen:						
Rock slinger	6.44	.61	.75	.50	.01	
Bridge, dock carpenters; derrick bargemen	6.46	.61	.75	.50	.01	
Head rock slingers	6.56	.61	.75	.50	.01	
Cementmasons:						
Cementmasons	5.77	.80	.85	.60	.0225	
Cement floating and finishing operators	6.02	.80	.85	.60	.0225	
Drywall installers	7.25	.46	.85	.50	.04	
Electricians:						
Electricians	8.95	.30	1%+.45		.02	
Cable splicers	9.25	.30	1%+.45		.02	
Sound technicians (new building construction)	6.83		1%		20.00p/y	
Sound technicians (modification of existing buildings and structures)	6.31		1%		20.00p/y	
Electricians (tunnel):						
Electricians	9.85	.30	1%+.45		.02	
Cable splicers	10.15	.30	1%+.45		.02	
Elevator constructors	7.58	.185	\$0.20	2%+a		
Elevator constructors' helpers	70% J.R.	.185	.20	2%+a		
Elevator constructors' helpers (prob.)	80% J.R.					
Glaziers	\$7.03	.30	.30		.04	
Ironworkers:						
Reinforcing	7.98	.43	.425	\$0.50	.02	
Fence erectors	7.89	.43	.425	.50	.02	
Ornamental; structural	8.03	.43	.425	.50	.02	
Irrigation and lawn sprinklers	6.50	10%	10%	12%	1%	
Lathers (except city of Lancaster):						
Metal furring	7.12	\$0.29	\$0.50		\$0.03	
Nail on (Area I)*	6.985	.29	.35		.045	
Nail on (Area II; III; IV)**	7.12	.39	.50		.03	
Line construction:						
Groundmen	6.74		1%			
Linemen	8.98		1%			
Cable splicers	9.28		1%			
Painters (except Pomona area):						
Brush	6.75	.305	.30	\$0.25		
Bridge; paint burner; steel; taper	6.57	.305	.30	.25		
Brush swing stage (13 stories or less); Paperhanger; sandblasters; spray	7.00	.305	.30	.25		
Bridge swing stage; steel swing stage	7.15	.305	.30	.25		
Spray, sandblaster swing stage (13 stories or less)	7.25	.305	.30	.25		
Steeplejack work	8.00	.305	.30	.25		
Painters (eastern portion—Pomona area):						
Brush, paint burner	6.93	.39	.39	.60	.03	
Paperhangers; sheetrock taper; swing stage iron, steel and bridge; sandblasters; iron, steel, and bridge, spray (groundwork)	7.43	.39	.39	.60	.03	
Brush swing stage; spray	7.18	.39	.39	.60	.03	
Steeplejack	8.33	.39	.39	.60	.03	

Classification	Basic hourly rates	Fringe benefits payments				
		H & W	Pensions	Vacation	App. Tr.	Other
Painters:						
Parking lot stripping work and/or highway markers	4.88	.20	.20	b		
Parking lot stripping work and/or highway markers' helpers; sandblaster	4.38	.20	.20	b		
Plasterers	7.495	.53	1.25	.50	.07	
Plumbers; steamfitters; lead burners	8.30	10%	16%	18%	1%	
Roofers	6.29	\$0.33	\$0.35		\$0.02	
Sheet metal workers (that portion of Los Angeles County north of a straight line drawn between Gorman and Big Pines)	7.07	.39	.23			
Sheet metal workers (remaining portion)	6.27	.39	.40		.025	
Soft floor layers	7.29	.29	.28	\$0.39	.015	
Sprinkler fitters (Los Angeles and area within 25 miles); Pomona	8.69	.29	.25	1.40	.02	
Terrazzo workers	6.42	.15		.15		
Terrazzo workers' helpers:						
Floor machine operator and helper	5.38	.15		.45		
Tile setters	6.95	.145	.35		.02	
Tile setters' helpers	5.46	.145	.50		.08	
Riggers; welders: Receive rate prescribed for craft performing operation to which rigging or welding is incidental.						
2-California-SCAL-LAB-1-2-3-c:						
Laborers:						
Cleaning and handling of panel forms; concrete screeding for rough strike off; concrete, water curing; demolition laborer, the cleaning of brick and lumber; dry packing of concrete, plugging, filling of shoe-bolt holes; fire watcher, limbers, brush loaders, pilers, and debris handler; gas and oil pipeline; laborer, general or construction; laborer, temporary water and air lines; material hoesman (walls, slab, floors, and decks); mixer-truck chuteman (walls, slabs, decks, floors foundations, and footing-curb and gutter and sidewalks); rigging and signaling; slip form raisers; window cleaner	5.045	.45	.85	.30		
Cutting torch (demolition); sealer; tarman; mortarman	5.095	.45	.85	.30		
Guinea chaser	5.225	.45	.85	.30		
Asphalt shoveler; fine grader, highway and street paving, airports, runways, and similar type heavy construction; landscape gardener and nurseryman	5.145	.45	.85	.30		
Packing rod steel and pans; tanks scaler and cleaner	5.17	.45	.85	.30		
Underground (including caisson bellow)	5.175	.45	.85	.30		
Chuck tender; septic tank digger and installer	5.195	.45	.85	.30		
Cesspool digger and installer	5.225	.45	.85	.30		
Concrete curer-impermeable membrane and form oiler; riprap stonepaver placing stone or sacked concrete; sandblaster (pot tender)	5.235	.45	.85	.30		
Pipelayers' backup man, coating, grouting, making of joints, sealing, caulking	5.335	.45	.85	.30		
Buggy/mobile man; cement dumper (on 1 yd. or larger mixer and handling bulk cement); gas and oil pipeline wrapper, pot tender; power broom sweepers (small); roto scraper and tiller; tree climber, faller, chain saw operator, Pittsburgh chipper and similar type brush shredders; trenching machine, hand propelled	5.255	.45	.85	.30		
Asphalt raker, luteman and ironer; concrete core cutter, grinder or sander concrete saw man, cutting, scoring old or new concrete; impact wrench, multiplate; pneumatic, gas, electric tools, vibrating machines and similar mechanical tools not separately classified herein; tampers, Burko Wacker and similar type	5.355	.45	.85	.30		
Rock slinger	5.305	.45	.85	.30		
Driller, jackhammer—2½ drill steel or longer	5.435	.45	.85	.30		
Concrete vibrator operator, 70 lbs. and over	5.465	.45	.85	.30		
Pipelayer (nonmetallic including sewer, drain, and underground tile); prefabricated manhole installer	5.455	.45	.85	.30		
Gas and oil pipeline wrapper (6 in. and over; kettlemen, potmen, and men applying asphalt, lay-kold, cresote, lime caustic, and similar type materials	5.385	.45	.85	.30		
Cribber, shorer, lagging, sheeting, and trench bracing, hand-guided lagging hammer	5.395	.45	.85	.30		
Blast powderman	5.47	.45	.85	.30		
Steel headerboard man and guideline setter	5.405	.45	.85	.30		
Sandblaster (nozzleman)	5.595	.45	.85	.30		
Driller (core-diamond-wagon)	5.595	.45	.85	.30		
Head rock slinger	5.565	.45	.85	.30		
Guniting laborers:						
Nozzlemen and rodmen	6.37	.45	.85	.30		
Gunmen	5.87	.45	.85	.30		
Reboundmen	5.11	.45	.85	.30		
2-California-SCAL-PEO-1-2-3-d:						
Power equipment operators:						
Group I:						
Brakeman; compressor operator; deckhand; engineer oiler; generator operator; heavy-duty repairman helper; pump operator; signalman; switchman	6.03	.45	.80	.30	.02	
Group II:						
Concrete mixer, skip-type; conveyor; fireman; generator, pump or compressor (2-5 inclusive) portal units—over 5 units, 10 cents per hour for each additional unit up to 9 units; hydrostatic pump; oiler crusher (asphalt or concrete plant); plant operator, generator, pump or compressor; skiploader, wheel-type up to ¼ yd. without attachment; tar pot fireman; temporary heating plant operator; trenching machine oiler; truck crane oiler	6.27	.45	.80	.30	.02	
Group III:						
A-frame or winch truck; chalmun; elevator (inside); equipment greaser (rack); Ford Ferguson (with drag-type attachments); power concrete curing machine; power concrete saw; power-driven jumbo form setter; Ross carrier (jobsite); stationary pipe wrapping and cleaning machine	6.51	.45	.80	.30	.02	
Group IV:						
Asphalt plant fireman; boring machine; boxman or mixerman (asphalt or concrete); chip spreading machine; concrete pump (small portable); bridge-type unloader and turntable; dinky locomotive or motorman (up to and including 10 tons); equipment greaser (grease truck); helicopter hoist operator; highline cableway signalman; hydra-hammer-aero stomper; power sweeper; roller (compacting); screed (asphalt or concrete); rodman; trenching machine (up to 6 ft.)	6.02	.45	.80	.30	.02	
Group V:						
Asphalt plant engineer; concrete batch plant operator (oiler or journeyman-trainee required); backhoe (up to and including ¾ yds.); bit sharpener; concrete joint machine operator (canal and similar type); concrete planer; derrickman (oilfield-type); deck engine operator; drilling machine (including water wells); forklift (under 5-ton capacity); hydrographic seeder machine (straw, pulp, or seed); machine tool; magnin's internal full slab vibrator; mechanical borm, curb or gutter (concrete or asphalt); mechanical finisher operator (concrete Clary-Johnson-Bidwell or similar); pavement breaker (truck mounted, oiler) road oil mixing machine; roller operator (asphalt or finish); rubber-tired earth-moving equipment (single engine, up to and including 25 yds. struck); self-propelled tar pipelining machine operator; slip form pump (power-driven hydraulic lifting device for concrete forms); tugger hoist (1-drum); tunnel locomotive operator (over 10 and up to and including 30 tons); stinger crane (Austin-Western or similar type); skiploader operator (Crawler and wheel-type over ¼ yd. and up to and including 1¼ yds.); tractor operator-bulldozer, tamper scraper (single engine, up to 100 hp. flywheel and similar types, up to and including D-5 and similar types)	6.81	.45	.80	.30	.02	

2-California—SCAL-PEO-1-2-3-d—Continued

Classification	Basic hourly rates	Fringe benefits payments				
		H & W	Pensions	Vacation	App. Tr.	Other
2-California—SCAL-PEO-1-2-3-d—Continued						
Power equipment operators—Continued						
Group VI:						
Asphalt or concrete spreader (tamping or finishing); asphalt paving machine (Barber Green or similar type—2 screedmen required); BHL lima road pactor, Wagner pactor or similar; bridge crane operator; cast in place pipelaying machine operator; combination mixer and compressor (gunite work); concrete pump (truck mounted) (oilier required); concrete mixer operator—paving; crane operator (up to and including 26-ton capacity); crushing plant operator; elevating grader forklift (over 5 tons); grade checker; gradall operator; grouting machine; heading shield; heavy-duty repairman; hoist operator (Chicago boom and similar type); Kokman belt loader and similar type; LeTourneau blob compactor or similar type; lift slab machine (Vagbury and similar type); LeTourneau blob compactor operator (Athey, Euclid, Sierra, and similar types); lift mobile operator; loader (3½ yd. rubber-tired, rail- or truck-type); pneumatic concrete placing machine (Hackley-Preswell or similar type); pneumatic heading shield (tunnels); pumperete gun; rotary drill (excluding Calson-type); rubber-tired earthmoving equipment (single engine—Caterpillar, Euclid, Athey Wagon, and similar types with any and all attachments over 25 yds. and up to and including 50 cu. yds. struck); rubber-tired scraper (self-loading—paddle wheel type; skiploader (crawler and wheel-type—over 1½ yds., up to and including 6½ yds.); surface heaters and planer; rubber-tired earthmoving equipment, multiple engine (up to and including 25 yds. struck); trenching machine (over 6 ft. depth capacity, manufacturers rating); tower crane; tractor compressor drill combination; tractor (any type larger than D-5—100 flywheel hp. and over, or similar) (bulldozer, tamper, scraper, and push tractor, single engine); tractor (boom attachments); traveling pipe wrapping, cleaning and bending machine; tunnel locomotive (over 30-ton); shovel, backhoe, dragline, clamshell (over 5½ yds. and up to 5 cu. yds. m.r.c.)	6.91	.45	.80	.30	.02	
Group VII:						
Crane—Over 25 tons up to and including 100 tons; derrick barge; dual drum mixer; mono-rail locomotive (diesel, gas, or electric); motor patrol—blade (single engine); multiple engine tractor (Euclid and similar type, except Quad 9 Cat); rubber-tired earthmoving equipment, single engine over fifty (50) yds. struck; rubber-tired earthmoving equipment (multiple engine, Euclid, Caterpillar, and similar) (over 25 yds. and up to 50 cu. yds. struck); tractor loader (crawler and wheel-type over 6½ yds.); tower crane repairman; shovel, backhoe, dragline, clamshell (over 5 cu. yds. m.r.c.); woods mixer and similar pugmill equipment; heavy-duty repairman—welder combination	7.01	.45	.80	.30	.02	
Group VIII:						
Auto grader operator; automatic slip form; crane—over 100 tons; hoist, stiff legs, guy derricks or similar types (capable of hoisting 100 tons or more); mass excavator; mechanical finishing machine; motor patrol (multiengine); pipe mobile machine; rubber-tired earthmoving equipment (multiple engine, Euclid, Caterpillar, and similar type over 50 cu. yds. struck); rubber-tired scraper (push-pull) (30 cents per hour additional to base rate); tandem equipment operator (2 units only); tandem tractor operator (Quad 9 or similar type); tunnel mole boring machine operator	7.15	.45	.80	.30	.02	
Group IX:						
Canal liner; canal trimmer; helicopter pilot; highline cableway; rubber-tired self-loading scraper (paddle wheel—Auger-type self-loading—2 or more units); wheel excavator (over 750 cu. yds.); remote controlled earth moving equipment operator (\$1 per hour additional)	7.25	.45	.80	.30	.02	
2-California—SCAL-TD-1-2-3-4:						
Truckdrivers:						
Truck repairman (welder)	6.115	.65	.45	.55		
Dump (40 yds. or more water level, single unit or combination of vehicles); DW 10 and DW 20 Euclid-type equipment, LeTourneau pulls, Terra Cobras and similar types of equipment; also PB and similar type truck when performing work within Teamsters jurisdiction regardless of types of attachments and when pulling aqua pak and water tank trailer; truck repairman	5.80	.65	.45	.55		
Dump (25 yds. but less than 40 yds. water level)	6.015	.65	.45	.55		
A-frame or Swedish crane, or similar type equipment driver; forklift; Ross carrier (highway)	5.735	.65	.45	.55		
Dump (16 yds., but less than 25 yds. water level); legal payload capacity (20 tons or more); dumper or dumpter truck; transit-mix (3 yds. or more); dumperete (6½ yds. water level and over)	5.43	.65	.45	.55		
Truck greaser and tireman	5.38	.65	.45	.55		
Water or tank-type truck driver (4,000 gals. and over)	5.35	.65	.45	.55		
Transit-mix truck (under 3 yds.); dumperete truck (less than 6½ yds. water level)	5.29	.65	.45	.55		
Truck repairman helper	5.285	.65	.45	.55		
Cement distributor truck; fuel truck; water or tank-type (2,500 gals. to 4,000 gals.)	5.25	.65	.45	.55		
Dump (12 yds. but less than 16 yds. water level); legal payload capacity (15 tons to 20 tons)	5.21	.65	.45	.55		
Dump (8 yds. but less than 12 yds. water level); legal payload capacity (10 tons to 15 tons)	5.13	.65	.45	.55		
Truck mounted power broom; warehouseman—clerk; water or tank-type (under 2,500 gals.)	5.11	.65	.45	.55		
Dump (4 yds. but less than 8 yds. water level); legal payload capacity (6 tons to 10 tons)	5.08	.65	.45	.55		
Dump (less than 4 yds. water level); traffic-control pilot car, excluding moving heavy equipment; legal payload capacity (less than 6 tons)	5.05	.65	.45	.55		
Warehouseman and teamster	4.97	.65	.45	.55		

Paid holidays:

A—New Year's Day; B—Memorial Day; C—Independence Day; D—Labor Day; E—Thanksgiving Day; F—Christmas Day.

Footnotes:

a. Employer contributes 4 percent basic hourly rate for over 5 years' service and 2 percent basic hourly rate for 6 months to 5 years' service as Vacation Pay Credit. Six paid holidays: A through F.

b. Employer contributes \$0.17 per hour to Holiday Fund plus \$0.10 per hour to Vacation for 1 year's service, \$0.20 per hour after 1 year but less than 5 years' service, \$0.30 per hour after 5 years but less than 10 years' service, \$0.40 per hour after 10 years' service.

*Area I—That portion of Los Angeles County including the cities of Burbank, Castale, Chatsworth, Cornell, Glendale, Hermosa Beach, Hollywood, Los Angeles, Malibu Beach, Redondo Beach, San Fernando, Santa Monica, Torrance, Van Nuys, Whittier, and Zuma Beach.

**Areas II; III; and IV:

Area II—That portion of Los Angeles County including the cities of Pomona, El Monte, Covina, Alhambra, Pasadena, South Pasadena, La Canada, to line that intersects Acton, east to San Bernardino County line, then south along the San Bernardino County line.

Area III—Beginning at the edge of Reeves Field, north along Long Beach City limits to 233d Street, west to Avalon Boulevard, north to Torrance Boulevard, west to Pacific Ocean, including Santa Catalina Island.

Area IV—Beginning at the edge of Reeves Field, north along Long Beach City limits to 233d Street, west to Avalon Boulevard, north to Rosecrans Avenue, east to Atlantic Avenue, north to Imperial Highway, east to the Orange County line, south along County line to Western Avenue, south to Lincoln Avenue, east to Highway 39 (Beach Boulevard), south to the Pacific Ocean, including San Clemente Island.

State: Nebraska; County: Lancaster; Decision No. AM-6140, date of decision: November 12, 1971.

Description of work: Residential construction consisting of single family homes and garden-type apartments up to and including four stories.

MODIFICATIONS

Classifications	Basic hourly rates	Fringe benefits payments				
		H & W	Pensions	Vacation	App. Tr.	Other
55-Nebraska-LAN-Res:						
Carpenters	\$3.70	\$0.07				
Cementmasons	3.92	.07				
Electricians	7.05	.20				
Laborers:						
Laborers	2.25	.07				
Painters, brush	3.57	.07				
Plumbers	6.77	.58	\$0.55	\$0.25	\$0.05	
Roofers	3.90	.07				
Sheet metal workers	4.85	.02	.06	.28		
Truckdrivers	2.75	.07				
Power equipment operators:						
Bulldozers	3.95	.07				

State: South Dakota; County: Minnehaha; Decision No. AM-6, 141, date of decision: November 12, 1971.

Description of work: Residential construction consisting of single family homes and garden-type apartments up to and including four stories.

MODIFICATIONS

Classification	Basic hourly rates	Fringe benefits payments				
		H & W	Pensions	Vacation	App. Tr.	Other
49-South Dakota-MINN-Res:						
Bricklayers	\$6.75					
Carpenters	5.85					
Cementmasons	4.85					
Electricians	4.75					
Laborers	3.80					
Painters, brush	4.48					
Plumbers	5.04	\$0.15	\$0.10	\$0.07	\$0.01	
Roofers	4.00					
Power equipment operators:						
Bulldozer	3.00					

State: Texas; Dallas, Denton, Collin, Hunt, Rockwall, Kaufman, and Ellis Counties; Decision No. AM-7, 487, date of decision: November 12, 1971.

Description of work: Residential construction consisting of single family homes and garden-type apartments up to and including four stories.

MODIFICATIONS

Classification	Basic hourly rates	Fringe benefits payments				
		H & W	Pensions	Vacation	App. Tr.	Other
11-Texas-4R V:						
Bricklayers	\$4.00					
Carpenters	4.50				\$0.02	
Cementmasons	3.50					
Concrete finisher (paving)	2.90					
Concrete finisher helper (paving)	2.05					
Electricians	3.25					
Form setter (paving and curb)	2.25					
Laborers:						
Laborers, unskilled	1.75					
Laborer, utility man	1.75					
Asphalt rakers	2.25					
Asphalt heaterman	1.75					
Mason tenders	2.00					
Mortar mixers	2.00					
Pipelayers (Concrete and clay)	1.75					
Tile setters	4.00					
Tile setters' helpers	2.25					
Painters, brush	3.25					
Plumbers	4.00					
Reinforced steel setter	2.00					
Roofers	3.00					
Sheet metal workers	3.50					
Soft floor layers	3.00					
Tape and bedmen	3.50					
Truck drivers	1.75					
Welder	3.25					
Power equipment operators:						
Asphalt paving machine	2.00					
Bulldozers	2.50					
Concrete paving saw	1.875					
Forklift	3.00					
Motor graders	2.50					
Backhoes	2.50					
Mixers	2.50					
Front end loaders	2.85					
Others	1.75					
Rollers	2.125					
Foundation boring machine	3.00					
Tractor, pneumatic (over 90 hp.)	2.75					
Scrapers	2.50					
Trenching machines	2.47					

State: Texas; County: *See below; Decision No. AM-7,488, date of decision: November 12, 1971.

Description of work: Residential construction consisting of single family homes and garden-type apartments up to and including four stories.

MODIFICATIONS

Classifications	Basic hourly rates	Fringe benefits payments				
		H & W	Pensions	Vacation	App. Tr.	Other
14-Texas-4R:						
Bricklayers	\$5.00					
Bricklayers' helpers	3.00					
Carpenters	4.40					
Carpenters' helpers	2.50					
Cementmasons	3.25					
Electricians	4.48					
Electricians' helpers	2.54					
Ironworkers, reinforcing	3.00					
Laborers	2.25					
Painters, brush	3.50					
Painters, spray	4.335					
Plumbers	5.05	\$0.22	\$0.37	\$0.50	\$0.05	
Plumbers' helpers	3.15					
Roofers	3.50					
Tile setters	3.50					
Tile setters' helpers	2.50					
Power equipment operators:						
Asphalt distributor	3.00					
Asphalt paving machine	2.85					
Bulldozer, 80 hp. and less	3.25					
Bulldozer, over 80 hp.	3.50					
Concrete paving curing machine	3.35					
Concrete paving finishing machine	3.00					
Concrete paving longitudinal float	3.15					
Concrete paving mixer	3.50					
Concrete paving saw	2.75					
Concrete paving spreader	3.25					
Concrete paving subgrader	3.50					
Crane, clamshell, backhoe, derrick, dragline, shovel (less than 1½ cu. yds.)	3.40					
Crane, clamshell, backhoe, derrick, dragline, shovel (1½ cu. yds. and over)	3.50					
Crusher and screening plant operator	3.10					
Foundation drill operator (crawler mounted)	3.75					
Foundation drill operator (truck mounted)	3.15					
Foundation drill operator helper	2.75					
Front end loader (1 cu. yd. and less)	2.70					
Front end loader (over 1 cu. yd.)	3.20					
Mixer (over 16 cu. ft.)	3.50					
Motor grader operator, fine grade	3.75					
Motor grader operator	3.00					
Roller, steel wheel (plant-mix pavements)	2.70					
Roller, steel wheel (other)	2.75					
Roller, pneumatic (self-propelled)	2.50					
Scrapers (7 cu. yds. and less)	2.85					
Scrapers (over 7 cu. yds.)	2.90					
Self-propelled-hammer	2.60					
Tractor (crawler-type) 80 hp. and less	2.25					
Tractor (crawler-type) over 80 hp.	3.00					
Tractor (pneumatic) 80 hp. and less	2.35					
Tractor (pneumatic) over 80 hp.	2.50					
Traveling plant (stabilization)	3.40					
Truckdrivers:						
Single axle, light	2.50					
Single axle, heavy	2.50					
Tandem axle or semitrailer	2.50					
Transit-mix	2.75					
Winch	2.55					
Wighman (truck scales)	2.25					

*Harris, Walker, Montgomery, Austin, Fort Bend, Brazoria, and Matagorda Counties.

State: Texas; County: Harris; Decision No. AM-7,489, date of decision: November 12, 1971.

Description of work: Building construction (excluding single family homes and garden-type apartments up to and including four stories).

MODIFICATIONS

Classification	Basic hourly rates	Fringe benefits payments				
		H & W	Pensions	Vacation	App. Tr.	Other
14-Texas-1-g:						
Building construction:						
Asbestos workers	\$6.32	\$0.275	.30			
Boilermakers	6.50	.30	.40		\$0.01	
Bricklayers	6.50	.175	.30		.03	
Carpenters:						
Carpenters	5.70	.25	.22		.015	
Millwrights	5.87	.33	.22		.015	
Piledrivermen	5.79	.25	.22			
Cementmasons	5.75	.30	.35		.02	
Electricians	6.66	.25	1%+ .15	\$0.225	.01	
Elevator constructors	6.00	.195	\$0.20	2%+a+b		
Elevator constructors' helper	70% J.R.	.195	.20	2%+a+b		
Elevator constructors' helpers (prob.)	80% J.R.					
Glaziers	\$5.80	.125	.10		.01	
Ironworkers:						
Structural; ornamental; reinforcing	6.575	.25	.40		.03	
Laborers:						
Common	4.55	.18	.10		.02	
Air tool operator (jackhammer-vibrator)	4.725	.18	.10		.02	
Mason tenders	4.725	.18	.10		.02	
Pipelayers (concrete and clay)	4.725	.18	.10		.02	
Sandblasters	4.725	.18	.10		.02	
Power buggy operator	4.725	.18	.10		.02	
Lather tenders	4.725	.18	.10		.02	
Mortar mixers	4.825	.18	.10		.02	
Well driller	4.825	.18	.10		.02	
Well driller helpers	5.10	.18	.10		.02	
Blasters, powderman	4.675	.18	.10		.02	
Plaster tender and hod carrier	4.975	.18	.10		.02	
	4.825	.18	.10		.02	

Classification	Basic hourly rates	Fringe benefits payments				
		H & W	Pensions	Vacation	App. Tr.	Other
14-Texas-1-q-Continued						
Building construction-Continued						
Lathers.....	6.35	.20	.15		.02	
Painters:						
Brush.....	5.585	.175	.25	\$0.10	.015	
Roller, steam cleaning, pneumatic tools.....	5.585	.175	.25	.10	.015	
Spray.....	5.95	.175	.25	.10	.015	
Sandblasting-waterblasting.....	5.95	.175	.25	.10	.015	
Steepjack work, hot materials.....	6.21	.175	.25	.10	.015	
Pipefitters.....	5.925	.225	.30		.035	
Plasterers.....	6.125	.17			.015	
Plumbers.....	6.20	.22	.42	.50	.05	
Roofers:						
Roofers.....	5.59	.20	.10	.15	.03	
Kettlemen.....	4.68	.20	.10	.15	.03	
Helpers.....	3.48	.20	.10	.15	.03	
Sheet metal workers.....	5.685	.125	.125	.15	.015	
Soft floor layers.....	6.00				.03	
Sprinkler fitters.....	7.00	.25	.40		.05	
Tile setters, marblemasons, mosaic and terrazzo workers.....	5.00					
Truckdrivers:						
Under 1½ tons; wash, grease, tireman, furl pump operation when used on construction jobs.....	5.05					
1½ through 2¼ tons; dump truck less than 7 yds.....	5.34					
Over 2¼ tons; farm tractors; forklifts, floats.....	5.50					
Euclids (not self-loading).....	5.00					
Warehousemen.....	5.24					
Material checkers; pickup drivers.....	6.01					
Welders—receive rate prescribed for craft performing operation to which welding is incidental.						
14-Texas-PEO-1:						
Building construction:						
Asphalt plant mixer operator; back filler; blade grader (self-propelled); building elevator (used on construction); built clam; bulldozer and all types cat tractors; cable way; clam shells, draglines, backhoes; concrete batch plant operator; concrete mixer (14 cu. ft. or more); crane—power operated (all types); crusher operator; derrick—power operated (all types); DW-10 caterpillar, 5-15 euclid and similar tractors; elevating grader (self-propelled); forklift used on construction (not including warehousing); foundation boring machine; gasoline or diesel-driven welding machines (7 or more); gradall; heavy-duty mechanic; high-lift; hoist (motor driven, 2 drums or more); locomotive crane; mix mobile; paving mixer (all types); piledriver; pneumatic rollers (self-propelled); pumperete machine operator; push cat operator; scoop-mobills; scraper (heavy type, over 3 cu. yds.); shovel (power operated); trenching machine (all sizes); tug boat operator (assigned to construction); turnapulls; water well drilling machines (used on construction); well point pump; winch truck; all other equipment of similar nature coming under the heavy equipment class, when power operated.....	6.10	.20	.30		.01	
Air compressors; blade grader (towed); concrete mixer (less than 14 cu. ft.); conveyor; flex plant; form grader; gasoline- or diesel-driven welding machines (on 3 or more, up to 6 machines); generator (gasoline or diesel driven, over 1,500 watts); hoist (single drum); pulsometer; pumps; rubber-tired farm tractor with attachments; scraper (3 cu. yds. or less); truck crane driver; wagon drill operator; a light equipment operator may run 1 or 2 105 c.f.m. compressors. All other equipment of similar nature coming under the light equipment class, when power operated.....	5.52	.20	.30		.01	
Fireman.....	5.12	.20	.30		.01	
Oiler.....	5.01	.20	.30		.01	
14-Texas-3 c:						
Incidental paving and utilities:						
Air tool man.....	2.00					
Asphalt raker.....	2.75					
Asphalt shoveler.....	2.50					
Batching plant scaleman.....	2.50					
Carpenter.....	3.75					
Carpenter helper.....	2.95					
Concrete finisher (paving).....	3.75					
Concrete finisher helper (paving).....	2.50					
Concrete finisher (structures).....	3.40					
Concrete finisher helper (structures).....	3.00					
Concrete rubber.....	3.00					
Electrician.....	4.65					
Fireman.....	3.00					
Form builder (structures).....	3.00					
Form builder helper (structures).....	2.75					
Form liner (paving and curb).....	3.35					
Form setter (paving and curb).....	3.25					
Form setter helper (paving and curb).....	2.75					
Form setter (structures).....	3.35					
Form setter helper (structures).....	2.50					
Laborer, common.....	2.00					
Laborer, utility man.....	2.55					
Manhole builder, brick.....	3.25					
Mechanic.....	3.75					
Mechanic helper.....	3.00					
Oiler.....	2.90					
Painter (structures).....	3.90					
Painter helper (structures).....	2.80					
Piledriverman.....	3.60					
Pipelayer.....	3.00					
Pipelayer helper.....	2.50					
Reinforcing steel setter (paving).....	2.75					
Reinforcing steel setter (structures).....	3.40					
Reinforcing steel setter helper.....	2.60					
Steel worker (structural).....	3.90					
Steel worker helper (structural).....	3.45					
Sign erector.....	3.00					
Spreader box man.....	3.50					
Power equipment operators:						
Asphalt distributor.....	3.25					
Asphalt paving machine.....	3.50					
Broom or sweeper operator.....	2.75					
Bulldozer, 150 hp. and less.....	3.25					
Bulldozer, over 150 hp.....	3.50					

Classification	Basic hourly rates	Fringe benefits payments				
		H & W	Pensions	Vacation	App. Tr.	Other
14-Texas—3 e—Continued						
Incidental paving and utilities—Continued						
Concrete paving curing machine	2.75					
Concrete paving finishing machine	3.25					
Concrete paving mixer	3.90					
Concrete paving saw	3.00					
Concrete paving spreader	3.25					
Crane, clamshell, backhoe, derrick, dragline, shovel (less than 1½ cu. yds.)	3.50					
Crane, clamshell, backhoe, derrick, dragline, shovel (1½ cu. yds. and over)	4.00					
Crusher or screening plant operator	3.25					
Foundation drill operator (truck mounted)	3.50					
Front end loader (2½ cu. yds. and less)	3.15					
Front end loader (over 2½ cu. yds.)	3.50					
Motor grader operator, fine grade	4.00					
Motor grader operator	3.50					
Roller, steel wheel (plant—mix pavements)	2.75					
Roller, steel wheel (other—flat wheel or tamping)	2.75					
Roller, pneumatic (self-propelled)	3.00					
Scrapers (17 cu. yds. and less)	3.00					
Scrapers (Over 17 cu. yds.)	3.25					
Tractor (crawler-type) 150 hp. and less	2.75					
Tractor (crawler-type) over 150 hp.	3.15					
Tractor (pneumatic) 80 hp. and less	2.55					
Tractor (pneumatic) over 80 hp.	2.75					
Traveling mixer	2.50					
Trenching machine, heavy	4.00					
Wagon drill, boring machine, or post hole driller operator	3.00					
Truckdrivers:						
Single axle, light	2.50					
Single axle, heavy	2.75					
Tandem axle or semitrailer	2.50					
Lowboy—float	2.75					
Winch	3.50					
Vibrator man (hand-type)	2.00					
Welder	4.50					
Welder helper	3.00					

Footnotes:
 a. First 6 months—none; 6 months to 5 years—2 percent; over 5 years—4 percent of basic hourly rates.
 b. Paid holidays—A through F.

Paid holidays:
 A—New Year's Day; B—Memorial Day; C—Independence Day; D—Labor Day; E—Thanksgiving Day; F—Christmas Day.

MODIFICATIONS

Classification	Basic hourly rates	Fringe benefits payments				
		H & W	Pensions	Vacation	App. Tr.	Other
WD No. AM-3,630—36 F.R. 17067, Adams, Arapahoe, southeast portion of Boulder (including city of Boulder) Denver, northern portion of Douglas, northern portion of Elbert, Jefferson, and the southwestern portion of Weld Counties, Colo. Modification No. 2						
CHANGE:						
Heavy and highway construction:						
Carpenters:						
Carpenters	\$5.72	\$0.35	\$0.35	\$0.20	\$0.015	
Carpenters used underground	5.87	.35	.35	.20	.015	
Carpenters working on cross-sited material—highwork, 40 ft. above ground on exposed scaffold or boatswains chair	5.97	.35	.35	.20	.015	
Piledriving work—sawmen continuously assigned to 1½ hp. saws at jobsite	5.97	.35	.35	.20	.015	
Colorado 1—PEO 1, 2, 3:						
Power equipment operators (other than for work in tunnels, shafts, and raises):						
Group I:						
Asphalt spread operator; brakeman; drill operator—William MF, similar and smaller; helper to heavy-duty mechanic and/or welder; tractor operator (under 70 hp.); oiler (assistant to engineer)	4.80	.25	.25		.03	
Group II:						
Air compressor operator; ditch witch trenching machine and similar; equipment lubricating and service engineer; forklift operator; haulage motorman (brakeman); operators of 1 or more light plants, welding machines, compressors 300 c.f.m. or less, pumps, generators; peagmill operator; peagmill (more than 1); pump operator; portable screening plant with or without a spray bar; screening plants—with classifier; self-propelled rollers—5 tons and under	5.15	.25	.25		.03	
Group III:						
Asphalt plant operator; backfiller operator; bituminous spreader or laydown machine; cableway signalman; caissons drill operator (William MF, similar and larger); C.M.I. and similar operator; concrete finish machine; concrete gang, saws on concrete paving; concrete mixer (less than 1 yd.); concrete placement pumps (under 8 in.); conveyor (handling building materials); distributors, bituminous surfaces; drill operators (diamond or core); drill rigs (rotary, churn or cable tool); elevating graders; engineer fireman; fireman or tank heater, road; grout machine; gunnite machine; hoists operator (1 drum); loader operator (Barber Greene, etc.); loader (up to and including 6 cu. yd.); machine doctor mechanic; motor grader (blade) operator; road stabilization machine; rollers—self-propelled—all types over 5 tons; sandblasting machine; scrapers—single bowl—under 40 cu. yd.; single unit portable crusher—with or without washer; tile tamper, wheel mounted; tractor operator (70 hp. and over) (with or without attachments); trenching machine operator rigged to dig 7 ft. or over; welder; winch operator on truck; concrete batching plants	5.50	.25	.25		.03	
Group IV:						
Concrete mixer (over 1 cu. yd.); concrete paver 34 E or similar; concrete placement pumps (8 in. and over); crane operator (50 tons and under); hoists (2 drums); loader—over 6 cu. yd.; mechanic—welder (heavy-duty); mixermobile; multiple unit portable crusher—with or without washer; piledriver; power shovels, draglines, clamshells, and backhoes (5 cu. yd. and under) (½ cu. yd. or over); scooper; scraper—all tandem bowls; scraper—single bowl including pups 40 cu. yd. and over; self-propelled hydrocrane; tractor with side boom; truck mounted hydrocrane	5.55	.25	.25		.03	
Group V:						
Climbing tower crane; crane operator—over 50 tons; derrick; electric rail-type tower crane; hoist (3-drum or more); power shovels, draglines, clamshells, and backhoes (over 5 cu. yd.); quad mine and similar push unit	5.80	.25	.25		.03	
Group VI:						
Cableway operator; crawler or truck mounted tower crane; wheel excavator	5.95	.25	.25		.03	

Classification	Basic hourly rates	Fringe benefits payments				
		H & W	Pensions	Vacation	App. Tr.	Other
CHANGE—Continued						
Colorado 1—PEO 1, 2, 3—Continued						
Power equipment operators (for work in tunnels, shafts, and raises):						
Air tractors	5.65	.26	.25		.03	
Brakeman	4.95	.20	.25		.03	
Compressor operator (servicing tunnels, shafts and raises)	5.40	.26	.25		.03	
Concrete placement pumps—8 in. and over discharge	5.50	.26	.25		.03	
Concrete placement pump under 8 in. discharge	5.65	.26	.25		.03	
Grout machine	5.65	.26	.25		.03	
Gunnite machine	5.65	.26	.25		.03	
Jumbo form operator	5.65	.26	.25		.03	
Mole operator	6.20	.26	.25		.03	
Motorman (brakeman)	5.30	.26	.25		.03	
Mucking machines and front end loaders underground	5.80	.26	.25		.03	
Slusher	5.80	.26	.25		.03	
WD No. AM-5,851—36 F.R. 17074, El Paso County, Colo. Modification No. 2						
CHANGE:						
Carpenters (heavy and highway):						
Carpenters	5.72	.35	.35	.20	.015	
Carpenters used underground	5.87	.35	.35	.20	.015	
Carpenters working on crocoated material—highwork, 40 ft. above ground on exposed scaffold or boatswains chair	5.97	.35	.35	.20	.015	
Piledriving work—sawmen continuously assigned to 1½ hp. saws at jobsite	5.97	.35	.35	.20	.015	
Colorado 1—PEO 1, 2, 3:						
Power equipment operators (other than for work in tunnels, shafts, and raises)						
Group I:						
Asphalt screed operator; brakeman; drill operator—William MF, similar and smaller; helper to heavy-duty mechanic and/or welder; tractor operator (under 70 hp.); other (assistant to engineer)	4.80	.26	.25		.03	
Group II:						
Air compressor operator; ditch witch trenching machine and similar; equipment lubricating and service engineer; forklift operator; haulage motorman (brakeman); operators of 1 or more light plants, welding machines, compressors 360 c.f.m. or less, pumps, generators; pugmill operator; pugmill (more than 1); pump operator; portable screening plant with or without a spray bar; screening plants—with classifier; self-propelled rollers—5 tons and under	5.15	.26	.25		.03	
Group III:						
Asphalt plant operator; backfiller operator; bituminous spreader or laydown machine; cableway signalman; caissons drill operator (William MF, similar and larger; C.M.I. and similar operator; concrete finish machine; concrete gang, saws on concrete paving; concrete mixer (less than 1 yd.); concrete placement pumps (under 8 in.); conveyor (handling building materials); distributors, bituminous surfaces; drill operators (diamond or core); drill rigs (rotary, churn or cable tool); elevating graders; engineer fireman; fireman or tank heater, road; grout machine; gunnite machine; hoists operator (1 drum); loader operator (Barber, Greene, etc.); loader (up to and including 6 cu. yd.); machine dozer mechanic; motor grader (blade) operator; road stabilization machine; rollers—self-propelled—all types over 5 tons; sandblasting machine; scrapers—single bowl—under 40 cu. yd.; single unit portable crusher—with or without washer; tile tamper, wheel mounted; tractor operator (70 hp. and over) (with or without attachments); trenching machine operator rigged to dig 7 ft. or over; welder; wheel operator on truck; concrete batching plants	5.50	.26	.25		.03	
Group IV:						
Concrete mixer (over 1 cu. yd.); concrete paver 34 E or similar; concrete placement pumps (8 in. and over); crane operator (50 tons and under); hoists (2 drums); loader—over 6 cu. yd.; mechanic—welder (heavy-duty); mixermobile; multiple unit portable crusher—with or without washer; piledriver; power shovels, draglines, clamshells, and backhoes (5 cu. yd. and under) (½ cu. yd. or over); scoop; scraper—all tandem bowl; scraper—single bowl including pups 40 cu. yd. and over; self-propelled hydrocrane; tractor with side boom; truck mounted hydrocrane	5.66	.26	.25		.03	
Group V:						
Climbing tower crane; crane operator—over 50 tons; derrick; electric rail-type tower crane; hoist (3-drum or more); power shovels, draglines, clamshells, and backhoes (over 5 cu. yd.); quad mine and similar push unit	5.80	.26	.25		.03	
Group VI:						
Cableway operator; crawler or truck mounted tower crane; wheel excavator	5.95	.26	.25		.03	
Power equipment operators (for work in tunnels, shafts, and raises):						
Air tractors	5.65	.26	.25		.03	
Brakeman	4.95	.26	.25		.03	
Compressor operator (servicing tunnels, shafts and raises)	5.40	.26	.25		.03	
Concrete placement pumps—8 in. and over discharge	5.50	.26	.25		.03	
Concrete placement pump under 8 in. discharge	5.65	.26	.25		.03	
Grout machine	5.65	.26	.25		.03	
Gunnite machine	5.65	.26	.25		.03	
Jumbo form operator	5.65	.26	.25		.03	
Mole operator	6.20	.26	.25		.03	
Motorman (brakeman)	5.30	.26	.25		.03	
Mucking machines and front end loaders underground	5.80	.26	.25		.03	
Slusher	5.80	.26	.25		.03	
WD No. AM-5,852—36 F.R. 17079, statewide counties, Colorado. Modification No. 2						
CHANGE:						
Carpenters						
Colorado 1—PEO 1, 2, 3:	5.72	.35	.35	.20	.015	
Power equipment operators (other than for work in tunnels, shafts, and raises):						
Group I:						
Asphalt screed operator; brakeman; drill operator—William MF, similar and smaller; helper to heavy-duty mechanic and/or welder; tractor operator (under 70 hp.); other (assistant to engineer)	4.80	.26	.25		.03	
Group II:						
Air compressor operator; ditch witch trenching machine and similar; equipment lubricating and service engineer; forklift operator; haulage motorman (brakeman); operators of 1 or more light plants, welding machines, compressors 360 c.f.m. or less, pumps, generators; pugmill operator; pugmill (more than 1); pump operator; portable screening plant with or without a spray bar; screening plants—with classifier; self-propelled rollers—5 tons and under	5.15	.26	.25		.03	

Classification	Basic hourly rates	Fringe benefits payments				
		H & W	Pensions	Vacation	App. Tr.	Other
CHANGE—Continued						
Colorado 1—PEO 1, 2, 3—Continued						
Power equipment operators (other than for work in tunnels, shafts, and raises)—Continued						
Group III:						
Asphalt plant operator; backfiller operator; bituminous spreader or laydown machine; cableway signalman; caissons drill operator (William MF, similar and larger); C.M.I. and similar operator; concrete finish machine; concrete gang, saws on concrete paving; concrete mixer (less than 1 yd.); concrete placement pumps (under 8 in.); conveyor (handling building materials); distributors, bituminous surfaces; drill operators (diamond or core); drill rigs (rotary, churn, or cable tool); elevating graders; engineer fireman; fireman or tank heater, road; grout machine; gunnite machine; hoists operator (1 drum); loader operator (Barber Greene, etc.); loader (up to and including 6 cu. yd.); machine doctor mechanic; motor grader (blade) operator; road stabilization machine; rollers—self-propelled—all types over 5 tons; sandblasting machine; scrapers—single bowl—under 40 cu. yd.; single unit portable crusher—with or without washer; tile tamper, wheel mounted; tractor operator (70 hp. and over) (with or without attachments); trenching machine operator rigged to dig 7 ft. or over; welder-winch operator on truck; concrete batching plants.....	5.50	.26	.25		.03	
Group IV:						
Concrete mixer (over 1 cu. yd.); concrete paver 34 E or similar; concrete placement pumps (8 in. and over); crane operator (50 tons and under); hoists (2 drums); loader—over 6 cu. yd.; mechanic—welder (heavy-duty); mixermobile; multiple unit portable crusher—with or without washer; piledriver; power shovels, draglines, clamshells, and backhoes (5 cu. yd. and under) (½ cu. yd. or over); scooper; scraper—all tandem bows; scraper—single bowl including pups 40 cu. yd. and over; self-propelled hydrocrane; tractor with side boom; truck mounted hydrocrane.....	5.05	.30	.25		.03	
Group V:						
Climbing tower crane; crane operator—over 50 tons; derrick; electric rail type tower crane; hoist (3 drum or more); power shovels, draglines, clamshells and backhoes (over 5 cu. yd.); quad mine and similar push unit.....	5.80	.26	.25		.03	
Group VI:						
Cableway operator; crawler or truck mounted tower crane; wheel excavator.....	5.95	.26	.25		.03	
Power equipment operators (for work in tunnels, shafts, and raises):						
Air tractor.....	5.65	.26	.25		.03	
Brakeman.....	4.95	.26	.25		.03	
Compressor operator (servicing tunnels shafts and raises).....	5.40	.26	.25		.03	
Concrete placement pumps—8 in. and over discharge.....	5.80	.26	.25		.03	
Concrete placement pump under 8 in. discharge.....	5.05	.26	.25		.03	
Grout machine.....	5.05	.26	.25		.03	
Gunnite machine.....	5.05	.26	.25		.03	
Jumbo form operator.....	5.05	.26	.25		.03	
Mole operator.....	5.05	.26	.25		.03	
Motorman (brakeman).....	6.20	.26	.25		.03	
Mucking machines and front end loaders underground.....	5.80	.26	.25		.03	
Slusher.....	5.80	.26	.25		.03	
<i>WD No. AM-376—96 F.R. 15791, Calhoun County, Mich., Modification No. 4</i>						
CHANGE:						
Piledrivermen (marine).....	7.05	.35	.40		.01	
ADD:						
Carpenters—heavy.....	6.55	.30	.30		.01	
Piledrivermen—heavy.....	6.55	.30	.30		.01	
<i>WD No. AM-377—96 F.R. 15795, Charlevoix County, Mich., Modification No. 5</i>						
ADD:						
Carpenters—heavy.....	6.44	.30	.30		.01	
Piledrivermen—heavy.....	6.44	.30	.30		.01	
<i>WD No. AM-379—96 F.R. 15804, Emmet County, Mich., Modification No. 5</i>						
ADD:						
Carpenters—heavy.....	6.39	.30	.30		.01	
Piledrivermen—heavy.....	6.39	.30	.30		.01	
<i>WD No. AM-381—96 F.R. 15813, Gogebic County, Mich., Modification No. 2</i>						
ADD:						
Carpenters—heavy.....	6.39	.30	.30		.01	
Piledrivermen—heavy.....	6.39	.30	.30		.01	
<i>WD No. AM-382—96 F.R. 15817, Grand Traverse and Leelanau Counties, Mich., Modification No. 3</i>						
ADD:						
Carpenters—heavy.....	6.44	.30	.30		.01	
Piledrivermen—heavy.....	6.44	.30	.30		.01	
<i>WD No. AM-383—96 F.R. 15822, Huron County, Mich., Modification No. 2</i>						
ADD:						
Carpenters—heavy.....	6.68	.30	.30		.01	
Piledrivermen—heavy.....	6.68	.30	.30		.01	
<i>WD No. AM-384—96 F.R. 15828, Ingham County, Mich., Modification No. 2</i>						
CHANGE:						
Carpenters.....	7.70	.35	.30		.01	
Piledrivermen.....	7.70	.35	.30		.01	
<i>WD No. AM-386—96 F.R. 15837, Kent County, Mich., Modification No. 4</i>						
ADD:						
Carpenters—heavy.....	6.55	.30	.30		.01	
Piledrivermen—heavy.....	6.55	.30	.30		.01	
<i>WD No. AM-387—96 F.R. 15843, Keweenaw, Houghton, Baraga, Ontonagon Counties, Mich., Modification No. 2</i>						
ADD:						
Carpenters—heavy.....	6.39	.30	.30		.01	
Piledrivermen—heavy.....	6.39	.30	.30		.01	
<i>WD No. AM-388—96 F.R. 15849, Marquette County, Mich., Modification No. 2</i>						
ADD:						
Carpenters—heavy.....	6.39	.30	.30		.01	
Piledrivermen—heavy.....	6.39	.30	.30		.01	
<i>WD No. AM-389—96 F.R. 15850, Mason County, Mich., Modification No. 3</i>						
CHANGE:						
Carpenters.....	7.10	.35	.40		.01	
Soft floor layers.....	7.10	.35	.40		.01	
Piledrivermen (marine construction).....	7.05	.35	.40		.01	
ADD:						
Carpenters—heavy.....	6.55	.30	.30		.01	
Piledrivermen—heavy.....	6.55	.30	.30		.01	

Classification	Basic hourly rates	Fringe benefits payments				
		H & W	Pensions	Vacation	App. Tr.	Other
<i>WD No. AM-390-36 F.R. 15855, Muskegon and Oceana Counties, Mich. Modification No. 3</i>						
CHANGE:						
Piledrivermen (marine construction).....	7.05	.35	.40		.01	
Carpenters (heavy).....	6.55	.30	.30		.01	
Piledrivermen (heavy).....	6.55	.30	.30		.01	
<i>WD No. AM-391-36 F.R. 15861, Saginaw County, Mich. Modification No. 3</i>						
ADD:						
Carpenters—heavy.....	6.68	.30	.30		.01	
Piledrivermen—heavy.....	6.68	.30	.30		.01	
<i>WD No. AM-3,010-36 F.R. 16883, Clay, Jackson, Platte, and Ray Counties, Mo., Modification No. 3</i>						
CHANGE:						
Building construction:						
Sheet metal workers.....	8.225	.25	.25			
<i>WD No. AM-1,858-36 F.R. 16206, Delaware County, Pa. Modification No. 2</i>						
Change:						
Pennsylvania—51-LAB-1-8:						
Building construction:						
Laborers:						
Stripping and dismantling concrete form work, loading, unloading, carrying and handling of all reinforced steel and steel mesh, handling lumber and other building materials, operating jackhammers, paving breakers and all other pneumatic tools, building scaffolds, raking, shoveling and tamping of asphalt, spading and concrete pit work, grading, form pinning, shoring, demolition except burners, laying conduits and ducts, sheathing, lagging, laying nonmetallic pipe and caulking, all other types of laborers.....	5.55	.20	.10			
Mason tender, power buggies, burners on demolition.....	5.65	.20	.10			
Wagon drill operator (single).....	5.70	.20	.10			
Powdermen, wagon drill operator (multiple).....	5.85	.20	.10			
Circular caissons excavation:						
Caisson groundmen.....	5.85	.20	.10			
Caisson bottommen.....	5.95	.20	.10			
Underpinning excavation:						
Laborers, working at depth of 8 ft. or under.....	5.85	.20	.10			
Yard workers.....	5.49	.20	.10			
ADD:						
Pennsylvania—51-LAB-2-3-E:						
Heavy and highway construction laborers:						
Powdermen, multiple wagon drill operators.....	5.85	.15	.10			
Finished surface asphalt rakers, operators, pipelayers, caulkers, conduct and duct layers.....	5.65	.15	.10			
Other pneumatic tool operators, laborers stripping concrete forms, carrying or handling lumber, steel and steel mesh and other concrete materials, form pinners, toolroom men, mortar mixers, concrete pitmen and spaders, grademen, asphalt shovelers, men working in sheeting, men working in shoring, men working in lagging, laborers assisting in the setting of cut stone, granite, or artificial stone, hod carriers, scaffold builders.....	5.55	.15	.10			
Wagon drill operators.....	5.70	.15	.10			
Yard workers:						
Laborers, scale mixermen, burnermen, dustmen, feeders.....	5.45	.15	.10			
Free air tunnels:						
Miners, miners bore driver, blasters, drillers, pneumatic shield operators, welders, and burners.....	5.975	.15	.10			
Miners' helpers, form setters.....	5.825	.15	.10			
Trackmen, brakemen, groutmen, bottom shaft men, all others in free air tunnels.....	5.675	.15	.10			
Circular caisson excavation bottommen.....	5.95	.15	.10			
Underpinning excavation bottommen.....	5.85	.15	.10			
All other laborers on construction work, with the exception of workers in compressed air.....	5.55	.15	.10			
<i>WD No. AM-1,860-36 F.R. 16206, Montgomery County, Pa. Modification No. 2</i>						
CHANGE:						
Pennsylvania—51-LAB-1-8:						
Building construction:						
Laborers:						
Stripping and dismantling concrete form work, loading, unloading, carrying, and handling of all reinforced steel and steel mesh, handling lumber and other building materials, operating jackhammers, paving breakers and all other pneumatic tools, building scaffolds, raking, shoveling, and tamping of asphalt, spading and concrete pit work, grading, form pinning, shoring, demolition except burners, laying conduits and ducts, sheathing, lagging, laying nonmetallic pipe and caulking, all other types of laborers.....	5.65	.20	.10			
Mason tender, power buggies, burners on demolition.....	5.65	.20	.10			
Wagon drill operator (single).....	5.70	.20	.10			
Powdermen, wagon drill operator (multiple).....	5.85	.20	.10			
Circular caissons excavation:						
Caisson groundmen.....	5.85	.20	.10			
Caisson bottommen.....	5.95	.20	.10			
Underpinning excavation:						
Laborers, working at depth of 8 ft. or under.....	5.85	.20	.10			
Yard workers.....	5.49	.20	.10			
Pennsylvania—51-LAB-2-3-E:						
Heavy and highway construction laborers:						
Powdermen, multiple wagon drill operator.....	5.85	.15	.10			
Finished surface asphalt rakers, operators, pipelayers, caulkers, conduct and duct layers.....	5.65	.15	.10			
Other pneumatic tool operators, laborers stripping concrete forms, carrying or handling lumber, steel and steel mesh and other concrete materials, form pinners, toolroom men, mortar mixers, concrete pitmen and spaders, grademen, asphalt shovelers, men working in sheeting, men working in shoring, men working in lagging, laborers assisting in the setting of cut stone, granite, or artificial stone, hod carriers, scaffold builders.....	5.55	.15	.10			
Wagon drill operators.....	5.70	.15	.10			
Yard workers:						
Laborers, scale mixermen, burnermen, dustmen, feeders.....	5.45	.15	.10			
Free air tunnels:						
Miners, miners bore driver, blasters, drillers, pneumatic shield operators, welders, and burners.....	5.975	.15	.10			
Miners' helpers, form setters.....	5.825	.15	.10			
Trackmen, brakemen, groutmen, bottom shaft men, all others in free air tunnels.....	5.675	.15	.10			
Circular caisson excavation bottommen.....	5.95	.15	.10			
Underpinning excavation bottommen.....	5.85	.15	.10			
All other laborers on construction work, with the exception of workers in compressed air.....	5.55	.15	.10			

Classification	Basic hourly rates	Fringe benefits payments			
		H & W	Pensions	Vacation	App. Tr. Other
<i>WD No. AM-1, 888-36 F.R. 16314, Philadelphia County, Pa. Modification No. 2</i>					
CHANGE:					
Pennsylvania-51-LAB-1-S:					
Building construction:					
Laborers:					
Stripping and dismantling concrete form work, loading, unloading, carrying, and handling of all reinforced steel and steel mesh, handling lumber and other building materials, operating jackhammers, paving breakers and all other pneumatic tools, building scaffolds, raking, shoveling, and tamping of asphalt, spading and concrete pit work, grading, form pinning, shoring, demolition except burners, laying conduits and ducts, sheathing, lagging, laying nonmetallic pipe and caulking, all other types of laborers	5.55	.20	.10		
Mason tender, power buggies, burners on demolition	5.65	.20	.10		
Wagon drill operator (single)	5.70	.20	.10		
Powdermen, wagon drill operator (multiple)	5.85	.20	.10		
Circular caissons excavation:					
Caisson groundmen	5.85	.20	.10		
Caisson bottomman	5.95	.20	.10		
Underpinning excavation:					
Laborers, working at depth of 8 ft. or under	5.85	.20	.10		
Yard workers	5.49	.20	.10		
Pennsylvania-51-LAB-2-3-E:					
Heavy and highway construction laborers:					
Powdermen, multiple wagon drill operator	5.85	.15	.10		
Finished surface asphalt rakers, operators, pipelayers, caulkers, conduct and duct layers	5.65	.15	.10		
Other pneumatic tool operators, laborers stripping concrete forms, carrying or handling lumber, steel and steel mesh and other concrete materials, form pinners, toolroom men, mortar mixers, concrete pitmen and spaders, grademen, asphalt shovelers, men working in sheeting, men working in shoring, men working in lagging, laborers assisting in the setting of cut stone, granite, or artificial stone, hod carriers, scaffold builders	5.55	.15	.10		
Wagon drill operators	5.70	.15	.10		
Yard workers:					
Laborers, scale mixers, burnermen, dustmen, feeders	5.45	.15	.10		
Free air tunnels:					
Miners, miners bore driver, blasters, drillers, pneumatic shield operators, welders, and burners	5.975	.15	.10		
Miners' helpers, form setters	5.825	.15	.10		
Trackmen, brakemen, groutmen, bottom shaft men, all others in free air tunnels	5.675	.15	.10		
Circular caisson excavation bottommen	5.95	.15	.10		
Underpinning excavation bottommen	5.85	.15	.10		
All other laborers on construction work, with the exception of workers in compressed air	5.55	.15	.10		
<i>WD No. AM-3, 867-36 F.R. 16787, Collin, Dallas, Ellis, Grayson, and Rockwall Counties, Tex. Modification No. 1</i>					
ADD TO DESCRIPTION OF WORK:					
Heavy construction.					
<i>WD No. AM-3, 871-36 F.R. 16781, Brazoria, Fort Bend, Galveston, Harris, Matagorda, Montgomery, Waller, and Wharton Counties, Tex. Modification No. 1</i>					
ADD TO DESCRIPTION OF WORK:					
Heavy construction.					
<i>WD No. AM-1, 845-36 F.R. 16241, Washington, D.C., Modification No. 2</i>					
CHANGE:					
Sewer and water lines:					
Power equipment operators:					
Backhoes, cableways, cranes, draglines, power shovels, tunnel shovels, tunnel mucking machines of 1 cu. yd. or above	6.14	.25	.25		.05
Backhoes, cableways, cranes, derricks, draglines, power shovels, tunnel mucking machines up to 1 cu. yd. and boom cuts, elevating graders, hoists, paving mixers, piledriving engines hatch plant, concrete pumps	5.89	.25	.25		.05
Trenching machines (above 8 ft. 3 in.)	5.69	.25	.25		.05
Backhoes (hydraulic, under 1 1/2 cu. yd.)	5.77	.25	.25		.05
Trenching machines (up to 8 ft. 3 in.), boilers skeleton, well drilling machines	5.59	.25	.25		.05
Air compressors, tunnel	5.56	.25	.25		.05
Front end loaders (high lift)	5.54	.25	.25		.05
Concrete mixers, power wheel scoops and scrapers, motor graders, tunnel motormen	5.44	.25	.25		.05
Mechanics	5.42	.25	.25		.05
Bulldozers, hydraulic tampers	5.34	.25	.25		.05
Roller	5.24	.25	.25		.05
Air compressors, pumps welding machines, well points	5.165	.25	.25		.05

[FR Doc.71-16416 Filed 11-11-71;8:45 am]

CUMULATIVE LIST OF PARTS AFFECTED—NOVEMBER

The following numerical guide is a list of parts of each title of the Code of Federal Regulations affected by documents published to date during November.

3 CFR	Page	9 CFR—Continued	Page	19 CFR	Page
PROCLAMATIONS:		PROPOSED RULES:		1	21335
3279 (amended by Proc. 4092)	21397	11	21318	4	21025
4091	21329	76	21652	16	21336
4092	21397	113	21058	20 CFR	
4093	21401	201	21683	PROPOSED RULES:	
EXECUTIVE ORDERS:		309	21414	404	21360, 21696
Nov. 9, 1871 (see PLO 5144)	21036	318	20984	21 CFR	
July 2, 1910 (revoked in part by PLO 5144)	21036	10 CFR		3	21587
June 16, 1911 (revoked in part by PLO 5144)	21036	50	21579	121	21588
Mar. 21, 1917 (revoked in part by PLO 5144)	21036	140	21580	130	21026
Dec. 9, 1926 (see PLO 5144)	21036	12 CFR		135	21404
11627 (amended by EO 11630)	21023	11	21451	135a	21404
11630	21023	210	21403	135b	21404, 21405
11631	21575	222	21666	135c	21184, 21404, 21452
5 CFR		225	21666	135e	20938, 21405
213	20931, 21577, 21665	545	21025	135g	21186
230	21180	563	21667	146c	21186
7 CFR		572	21667	146d	21188
20	21577	PROPOSED RULES:		146e	21188
601	21403	269	21212	148i	20938
777	21256	291	21212	308	21336
796	21277	545	21363	420	21189, 21190
815	21277	546	21066	PROPOSED RULES:	
874	21449	563	21067	3	21688
906	21403	13 CFR		27	20985
907	21119, 21577	120	21332	31	20985
908	21119, 21578	121	21183	148i	20985
910	20932, 21331	14 CFR		191	20985, 20986
912	21331	23	21278	311	21057
913	21331	25	21278	312	21057
926	21025	27	21278	22 CFR	
966	21449	29	21278	42	20939
1036	21578	39	21279, 21581, 21668	121	20939
1823	21666	65	21280	123	20940
1890p	21450	71	21029, 21030, 21182, 21280-21282, 21403, 21582-21584, 21670	124	20940
PROPOSED RULES:		75	21030, 21182, 21280-21282, 21403, 21582-21584, 21670, 21671	125	20941
724	21208	95	21030, 21584-21586, 21670, 21671	126	20942
780	21291	97	21282, 21673	201	21190
913	21522	103	21183	24 CFR	
928	20980	241	20933	242	21674
929	21411	PROPOSED RULES:		1914	20942, 21408, 21589
932	21059	39	21064, 21210	1915	20943, 21409, 21590
982	21411	47	21414	PROPOSED RULES:	
984	21291	71	21064, 21065, 21211, 21293, 21415, 21416, 21600, 21601, 21696, 21697	1710	21043
989	20981, 21599	225	21601	26 CFR	
1030	20981, 21413	245	21361	1	20944
1049	20981	1245	21068	PROPOSED RULES:	
1464	21209	16 CFR		1	20980, 21057, 21206, 21207, 21291
1701	21522	13	21586	28 CFR	
8 CFR		251	21517	50	21028
214	21277	410	21518	29 CFR	
9 CFR		PROPOSED RULES:		55	21282, 21337
76	20932, 21181	436	21607	PROPOSED RULES:	
92	20932	17 CFR		1904	21687
101	21579	240	21178	30 CFR	
102	21579	249	21178	81	21405
112	21579	PROPOSED RULES:		PROPOSED RULES:	
113	21579	240	21525	270	21610
114	21579	19 CFR		PROPOSED RULES:	
117	21579	PROPOSED RULES:		PROPOSED RULES:	
120	21579	PROPOSED RULES:		PROPOSED RULES:	
132	21579	PROPOSED RULES:		PROPOSED RULES:	

31 CFR	Page
405.....	21338
32 CFR	
1.....	21120
2.....	21128
3.....	21128
4.....	21131
5.....	21133
6.....	21136
7.....	21139
8.....	21152
9.....	21152
10.....	21153
11.....	21153
12.....	21153
13.....	21159
14.....	21160
15.....	21161
16.....	21167
17.....	21168
18.....	21168
19.....	21169
22.....	21169
24.....	21174
25.....	21174
26.....	21174
30.....	21175
45.....	21178
61.....	21339
65.....	21339
78.....	21339
87.....	21178
141.....	21339
187.....	21339
275.....	20944
713.....	21519
1467.....	21339
1806.....	21178
PROPOSED RULES:	
1600.....	21216
1602.....	21072
1603.....	21072
1604.....	21072, 21216
1606.....	21216
1609.....	21216
1611.....	21072
1613.....	21216
1617.....	21072, 21216
1619.....	21216
1621.....	21072, 21216
1622.....	21072
1623.....	21072
1624.....	21072
1625.....	21072
1626.....	21072
1627.....	21072
1628.....	21072
1630.....	21072
1631.....	21072
1632.....	21072
1642.....	21072
1655.....	21072
1660.....	21072, 21294
32A CFR	
OEP (Ch. I):	
ES Reg. 1:	
Circ. 25.....	21598
Ch. X.....	21284

33 CFR	Page
117.....	21359, 21590
208.....	21190
PROPOSED RULES:	
117.....	21063
199.....	21523
36 CFR	
7.....	20945, 21666
38 CFR	
3.....	20945
17.....	21030
21.....	21406
41 CFR	
1-16.....	21453
5A-1.....	21676
5A-2.....	21406
5B-2.....	21407
5B-18.....	21407
8-2.....	21676
8-4.....	21676
9-4.....	21191
14-1.....	20946
14-2.....	20947
14-3.....	20947
14-6.....	20947
14-7.....	20947
15-1.....	20947
15-3.....	21192
18-1.....	21454
18-2.....	21469
18-3.....	21472
18-5.....	21485
18-6.....	21485
18-7.....	21486
18-8.....	21492
18-9.....	21496
18-11.....	21498
18-13.....	21499
18-15.....	21500
18-16.....	21501, 21588
18-26.....	21504
18-50.....	21507
18-51.....	21508
18-52.....	21513
101-11.....	21031
101-26.....	21284
PROPOSED RULES:	
101-17.....	21059
101-18.....	21059
101-20.....	21059
42 CFR	
PROPOSED RULES:	
52.....	21292
73.....	21292, 21696
43 CFR	
4.....	21284
24.....	21034
2780.....	21677
3100.....	21035
PUBLIC LAND ORDERS:	
5116.....	21591
5142.....	21195
5143.....	21036
5144.....	21036
PROPOSED RULES:	
25.....	21207
3000.....	21610

43 CFR—Continued	Page
PROPOSED RULES—Continued	
3045.....	21610
3104.....	21610
3200.....	21610
45 CFR	
213.....	21520
249.....	21409, 21591
250.....	21591
801.....	20949
PROPOSED RULES:	
170.....	21600
46 CFR	
2.....	21196
146.....	21196, 21284
PROPOSED RULES:	
542.....	21524
546.....	21524
47 CFR	
1.....	21677
21.....	21677
73.....	21197, 21592
74.....	21677
81.....	20956
83.....	20970
85.....	20977
89.....	21200, 21677
91.....	21200, 21677
93.....	21200, 21677
95.....	21677
PROPOSED RULES:	
73.....	21066, 21293, 21602
74.....	20988
81.....	21602
83.....	21602
49 CFR	
171.....	21201
172.....	21201, 21287
173.....	21201, 21287, 21339, 21343
174.....	21201, 21202
175.....	21201
177.....	21201, 21202
178.....	21202, 21287
179.....	21339, 21343
566.....	20977
571.....	21355, 21594
1033.....	21203, 21452
1048.....	21452
1056.....	21358
1062.....	21596
PROPOSED RULES:	
173.....	21360
192.....	21698
195.....	21211
566.....	20987
1047.....	21071
1048.....	21524
1115.....	21698
1252.....	21610
50 CFR	
28.....	21203
32.....	21203, 21597
33.....	21407, 21520, 21597, 21598
260.....	21037
PROPOSED RULES:	
32.....	21411

LIST OF FEDERAL REGISTER PAGES AND DATES—NOVEMBER

Pages	Date	Pages	Date	Pages	Date
20925-21016.....	Nov. 2	21271-21321.....	5	21443-21567.....	10
21017-21112.....	3	21323-21391.....	6	21569-21658.....	11
21113-21270.....	4	21393-21442.....	9	21659-21745.....	12

PUBLIC PAPERS OF THE PRESIDENTS OF THE UNITED STATES

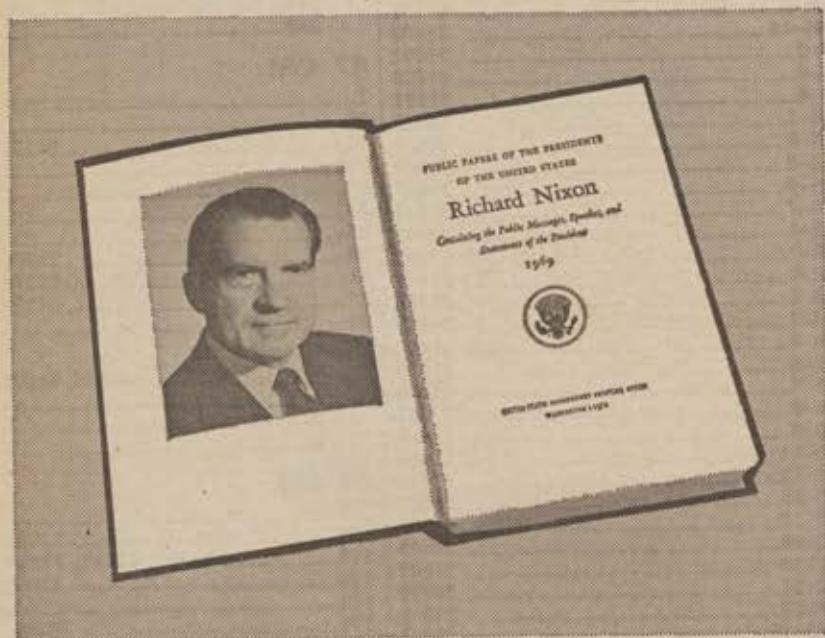

Richard Nixon — 1969

1183 Pages — Price: \$14.50

CONTENTS

- Messages to the Congress
- Public speeches and letters
- The President's news conferences
- Radio and television reports to the American people
- Remarks to informal groups

PUBLISHED BY

Office of the Federal Register
National Archives and Records
Service
General Services Administration

ORDER FROM

Superintendent of Documents
U.S. Government Printing Office
Washington, D.C. 20402

PRIOR VOLUMES

Volumes covering the administrations of Presidents Truman, Eisenhower, Kennedy, and Johnson are available at varying prices from the Superintendent of Documents, U.S. Government Printing Office, Washington, D.C. 20402.