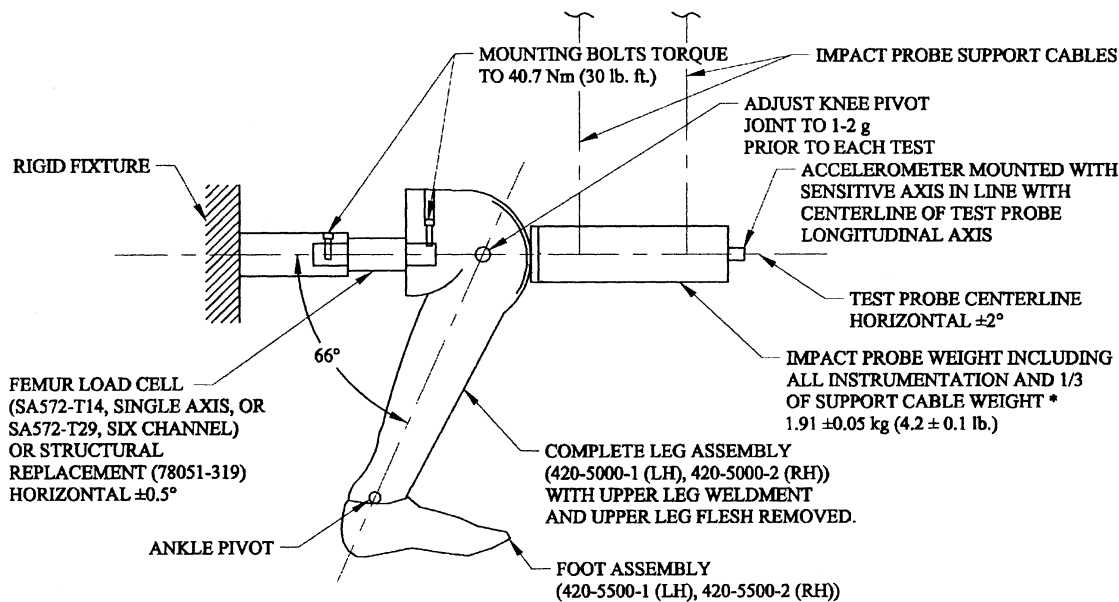

**FIGURE T6
KNEE IMPACT TEST SETUP SPECIFICATIONS**



* 1/3 CABLE WEIGHT NOT TO EXCEED 5% OF THE TOTAL IMPACT PROBE WEIGHT

Issued: June 28, 2005.

Stephen R. Kratzke,

Associate Administrator for Rulemaking.

[FR Doc. 05-13659 Filed 7-12-05; 8:45 am]

BILLING CODE 4910-59-C

DEPARTMENT OF COMMERCE

National Oceanic and Atmospheric Administration

50 CFR Part 229

[Docket No. 050127019-5178-02; I.D. 120304D]

RIN 0648-AS01

Taking of Marine Mammals Incidental to Commercial Fishing Operations; Atlantic Large Whale Take Reduction Plan Regulations

AGENCY: National Marine Fisheries Service (NMFS), National Oceanic and Atmospheric Administration (NOAA), Commerce.

ACTION: Proposed rule; extension of public comment period.

SUMMARY: On June 21, 2005, a proposed rule to amend the regulations implementing the Atlantic Large Whale Take Reduction Plan (ALWTRP) was published in the **Federal Register**. NMFS is extending the comment period on this proposed rule by 30 days to August 22, 2005, to allow the public a full 60 days to submit comments.

DATES: Comments on the proposed rule must be received by 5 p.m. EST on August 22, 2005.

ADDRESSES: Comments may be submitted on this proposed rule, identified by RIN 0648-AS01, by any one of the following methods:

(1) NMFS/Northeast Region website: <http://www.nero.noaa.gov/nero/reg/com.html>. Follow the instructions on the website for submitting comments.

(2) Federal eRulemaking Portal: <http://www.regulations.gov>. Follow the instruction on the website for submitting comments.

(3) E-mail: whalerule.comments@noaa.gov. Please include the RIN 0648-AS01 in the subject line of the message.

(4) Mail: Mary Colligan, Assistant Regional Administrator for Protected Resources, NMFS, Northeast Region, 1 Blackburn Dr., Gloucester, MA 01930, ATTN: ALWTRP Proposed Rule.

(5) Facsimile (fax) to: 978-281-9394, ATTN: ALWTRP Proposed Rule.

Copies of the Draft Environmental Impact Statement/Regulatory Impact Review for this action can be obtained from the ALWTRP website listed under the Electronic Access portion of this document. Atlantic Large Whale Take Reduction Team (ALWTRT) meeting summaries, and progress reports on implementation of the ALWTRP may be obtained by writing Diane Borggaard, NMFS, Northeast Region, 1 Blackburn Dr., Gloucester, MA 01930 or Juan Levesque, NMFS, Southeast Region, 9721 Executive Center Dr., St. Petersburg, FL 33702-2432. For

additional **ADDRESSES** and web sites for document availability see **SUPPLEMENTARY INFORMATION**.

FOR FURTHER INFORMATION CONTACT:

Diane Borggaard, NMFS, Northeast Region, 978-281-9300 Ext. 6503, diane.borggaard@noaa.gov; Kristy Long, NMFS, Office of Protected Resources, 301-713-2322, kristy.long@noaa.gov; or Barb Zoodsma, NMFS, Southeast Region, 904-321-2806, barb.zoodsma@noaa.gov.

SUPPLEMENTARY INFORMATION:

Electronic Access

Several of the background documents for the ALWTRP and the take reduction planning process can be downloaded from the ALWTRP web site at <http://www.nero.noaa.gov/whaletrp/>. Copies of the most recent marine mammal stock assessment reports may be obtained by writing to Richard Merrick, NMFS, 166 Water St., Woods Hole, MA 02543 or can be downloaded from the Internet at <http://www.nefsc.noaa.gov/psb/assesspdfs.htm>. In addition, copies of the documents entitled "Defining Triggers for Temporary Area Closures to Protect Right Whales from Entanglements: Issues and Options" and "Identification of Seasonal Area Management Zones for North Atlantic Right Whale Conservation" are available by writing to Diane Borggaard, NMFS, Northeast Region, 1 Blackburn Dr., Gloucester, MA 01930 or can be downloaded from the ALWTRP website at <http://www.nero.noaa.gov/whaletrp/>. The complete text of the regulations

implementing the ALWTRP can be found either in the Code of Federal Regulations (CFR) at 50 CFR 229.32 or downloaded from the website, along with a guide to the regulations.

Dated: July 8, 2005.

Rebecca Lent,

Deputy Assistant Administrator for Regulatory Programs, National Marine Fisheries Service.

[FR Doc. 05-13795 Filed 7-12-05; 8:45 am]

BILLING CODE 3510-22-S

DEPARTMENT OF COMMERCE

National Oceanic and Atmospheric Administration

50 CFR Part 660

[Docket No. 050620162-5162-01; I.D. 061505D]

RIN 0648-AS30

Fisheries off West Coast States and in the Western Pacific; Pelagic Fisheries; Additional Measures to Reduce the Incidental Catch of Seabirds in the Hawaii Pelagic Longline Fishery

AGENCY: National Marine Fisheries Service (NMFS), National Oceanic and Atmospheric Administration (NOAA), Commerce.

ACTION: Proposed rule; request for comments.

SUMMARY: This proposed rule would require all Hawaii-based longline fishing vessels to either side-set (set longline gear from the side of the vessel rather than from the stern), or use a combination of other seabird mitigation measures to prevent seabirds, e.g., Laysan and black-footed albatrosses, from being accidentally hooked or entangled, and killed during fishing operations. This proposed rule is also intended to reduce the potential for interaction with endangered short-tailed albatrosses that are known to be in the area in which the fishery operates.

DATES: Comments on the proposed rule must be received in writing by August 12, 2005.

ADDRESSES: You may submit comments on this proposed rule or its Initial Regulatory Flexibility Analysis (IRFA), identified by 0648-AS30 by any of the following methods:

- E-mail: AS30-Seabirds@noaa.gov. Include in the subject line of the e-mail comment the following document identifier: Seabird Measures. Comments sent via e-mail, including all attachments, must not exceed a 10 megabyte file size.

- Federal e-Rulemaking portal: <http://www.regulations.gov>. Follow the instructions for submitting comments.

- Mail: William L. Robinson, Administrator, NMFS, Pacific Islands Region (PIR), 1601 Kapiolani Boulevard, Suite 1110, Honolulu, HI 96814.

- Fax: 808-973-2941.

Copies of the regulatory amendment document (6 April 2005) entitled "Additional Measures to Reduce the Incidental Catch of Seabirds in the Hawaii-Based Longline Fishery" (containing a Regulatory Impact Review and IRFA) and Final Environmental Impact Statement (FEIS) prepared for this action may be obtained from William L. Robinson (see **ADDRESSES**). Requests should indicate whether paper copies or electronic copies on CD-ROM are preferred. These documents are also available at the following websites: www.wpcouncil.org and <http://swr.nmfs.noaa.gov/pir>.

FOR FURTHER INFORMATION CONTACT:

Robert Harman, NMFS PIR, 808-973-2937.

SUPPLEMENTARY INFORMATION: Hawaii-based longline fishing vessels inadvertently hook or entangle, and kill black-footed albatrosses (*Phoebastria nigripes*) and Laysan albatrosses (*Phoebastria immutabilis*) that nest in the Northwestern Hawaiian Islands (NWHI). Short-tailed albatrosses (*Phoebastria albatrus*), an endangered species that nests primarily on Tori Island off Japan and known to visit the NWHI, have been sighted occasionally in the vicinity of Hawaii longline vessels during fishing operations. However, there has been no confirmed report of any interaction between the short-tailed albatross and Hawaii longline fishery.

The Western Pacific Fishery Management Council (WPFMC) developed and proposed seabird mitigation measures for Hawaii-based longline vessels, but these were not finalized due to a Biological Opinion issued late in 2000 by the U.S. Fish and Wildlife Service (USFWS 2000 Biological Opinion) under section 7 of the Endangered Species Act (ESA). In mid-2001, NMFS implemented emergency seabird mitigation measures (66 FR 31561, 12 June 2001) in accordance with the terms and condition of the USFWS 2000 Biological Opinion on the short-tailed albatross.

On May 14, 2002, NMFS published a final rule (67 FR 34408) establishing permanent seabird mitigation measures recommended by the WPFMC for the Hawaii longline fishery. That rule, which replaced the 2001 emergency interim rule, is the result of the

WPFMC's continued effort and commitment to minimize interactions between seabirds and the Hawaii-based longline fishery. A description of the WPFMC's role and ongoing actions in seabird mitigation in the western Pacific region is contained in the regulatory amendment document entitled "Additional Measures to Reduce the Incidental Catch of Seabirds in the Hawaii-based Longline Fishery" (WPFMC, 6 April 2005, see **ADDRESSES**).

The May 2002 final rule required owners and operators of all vessels registered for use with Hawaii longline limited access permits and deploying longline gear north of 23° N. latitude to use line-setting machines (line shooters) with weighted branch lines, or use basket-style longline gear, and to use thawed, blue-dyed bait and strategic offal discards (which include fish, fish parts, or spent bait) during the setting and hauling of longline gear. The owners and operators of these vessels were also required to follow certain seabird handling techniques, and annually complete a protected species educational workshop on seabird mitigation conducted by NMFS.

Since 2000, the number of fishery interactions with all seabirds was significantly reduced due to the closure of the shallow-set (swordfish-directed) component of the Hawaii-based longline fishery. This closure was implemented by NMFS to protect sea turtles via a number of emergency actions (64 FR 72290, 27 December 1999; 65 FR 51992, 25 August 2000; 66 FR 15358, 19 March 2001) and a final rule (66 FR 31561, 12 June 2001).

Between 2002 and 2003, NMFS, WPFMC, and the fishing industry collaborated in a series of research activities to test new seabird deterrent methods for Hawaii longline vessels. The trials found that underwater setting chutes (which deploy baited hooks underwater and out of the reach of seabirds) and side-setting were both effective in reducing interactions with seabirds. These and other seabird deterrent strategies were analyzed and considered by the WPFMC as potential new seabird mitigation methods to cost-effectively further reduce the effects of the Hawaii longline fleet on seabirds.

In March 2004, in concert with the regulatory amendment to reopen the swordfish component of the Hawaii longline fishery, NMFS and USFWS reinitiated ESA section 7 consultations on the effect of the fishery on the short-tailed albatross. During the consultation process, NMFS and USFWS also held discussions with the Hawaii Longline Association and WPFMC staff that included the consideration of