

4. *Projected reporting, recordkeeping, and other compliance requirements.* There are no reporting, recordkeeping, or other compliance requirements associated with the revised Interpretation.

5. *Minimizing significant economic impact of the revised Interpretation on small entities.* There were no public comments that suggested a significant alternative that would minimize the impact of the proposal on small entities. There are eleven bankers' banks qualifying as "small entities" under RFA. The revised Interpretation provides all bankers' banks with the ability to maintain their exemption from reserve requirements, if any, while undertaking certain additional bankers' bank activities or customers as authorized by their chartering authorities. No bankers' bank is required to seek a determination under the revised Interpretation. The revised Interpretation imposes no economic burdens on bankers' banks, and instead only offers the opportunity to bankers' banks that are exempt from reserve requirements to maintain the economic benefits of that exemption under the specified circumstances. Accordingly, the Board believes that the revised Interpretation will not have a significant impact on a substantial number of small entities.

**B. Paperwork Reduction Act**

In accordance with the Paperwork Reduction Act (PRA) of 1995 (44 U.S.C. 3506; 5 CFR part 1320 Appendix A.10), the Board reviewed the proposal under the authority delegated to the Board by the Office of Management and Budget (OMB). The proposal contains no requirements subject to the PRA.

**VI. Plain Language**

The Board received one comment on whether the proposal was in plain language. This commenter stated that the Board's failure to propose standards for its exercise of authority under the proposal amounted to a failure to comply with the "Plain Language" provisions of the Gramm-Leach-Bliley act. This commenter stated that the Board should instead say that it proposes to do whatever it wants given its view of the purposes of the Act. For the reasons stated above, the Board believes that the revised Interpretation is stated in plain language to the greatest extent possible at this point in time. As also stated above, the Board expects to publish further guidance and standards as it obtains additional experience in the future with requests for determinations under the revised Interpretation. Accordingly, the Board

believes that the revised Interpretation complies with applicable plain language requirements.

**List of Subjects in 12 CFR Part 204**

Banks, banking, Reporting and recordkeeping requirements.

■ For the reasons set forth in the preamble, the Board is amending 12 CFR part 204 as follows:

**PART 204—RESERVE REQUIREMENTS OF DEPOSITORY INSTITUTIONS (REGULATION D)**

■ 1. The authority citation for part 204 continues to read as follows:

**Authority:** 12 U.S.C. 248(a), 248(c), 371a, 461, 601, 611, and 3105.

■ 2. The second sentence of paragraph (a)(2)(iii) of § 204.121 is revised to read as follows:

**§ 204.121 Bankers' banks.**

(a) \* \* \*

(2) \* \* \*

(iii) \* \* \* First, the range of customers with which the institution does business must be limited to depository institutions, including subsidiaries or organizations owned by depository institutions; directors, officers or employees of the same or other depository institutions; individuals whose accounts are acquired at the request of the institution's supervisory authority due to the actual or impending failure of another depository institution; share insurance funds; depository institution trade associations; and such others as the Board may determine on a case-by-case basis consistent with the purposes of the Act and the bankers' bank exemption. \* \* \*

\* \* \* \* \*

By order of the Board of Governors of the Federal Reserve System, April 3, 2007.

**Jennifer J. Johnson,**  
*Secretary of the Board.*

[FR Doc. E7-6473 Filed 4-5-07; 8:45 am]

**BILLING CODE 6210-02-P**

**DEPARTMENT OF TRANSPORTATION**

**Federal Aviation Administration**

**14 CFR Part 39**

[Docket No. FAA-2006-25105; Directorate Identifier 2006-CE-33-AD; Amendment 39-15016; AD 2007-06-01 R1]

RIN 2120-AA64

**Airworthiness Directives; Raytheon Aircraft Company Beech Models 45 (YT-34), A45 (T-34A, B-45), and D45 (T-34B) Airplanes**

**AGENCY:** Federal Aviation Administration (FAA), DOT.

**ACTION:** Final rule; correction.

**SUMMARY:** We are clarifying information contained in Airworthiness Directive (AD) 2007-06-01, which supersedes AD 62-24-01 and applies to all Raytheon Aircraft Company (RAC) Beech Models 45 (YT-34), A45 (T-34A, B45), and D45 (T-34B) airplanes. AD 2007-06-01 currently requires you to repetitively inspect, using the eddy current method, the front and rear horizontal stabilizer spars for cracks and replace any cracked stabilizer. We inadvertently left out the language in this AD that required replacement of any horizontal stabilizer spar found cracked prior to further flight although the procedures in the appendix made reference to corrective action. The replacement information was contained in the notice of proposed rulemaking (NPRM). This document adds this information already proposed back into the AD. We are issuing this AD to prevent failure of the front and/or rear horizontal stabilizer spars caused by fatigue cracks. This failure could result in stabilizer separation and loss of control of the airplane.

**DATES:** This AD becomes effective on April 16, 2007.

**ADDRESSES:** To view the AD docket, go to the Docket Management Facility, U.S. Department of Transportation, 400 Seventh Street, SW., Nassif Building, Room PL-401, Washington, DC 20590-001 or on the Internet at <http://dms.dot.gov>. The docket number is FAA-2006-25105; Directorate Identifier 2006-CE-33-AD.

**FOR FURTHER INFORMATION CONTACT:** T.N. Baktha, Aerospace Engineer, FAA, Wichita Aircraft Certification Office, 1801 Airport Road, Mid-Continent Airport, Wichita, Kansas 67209; telephone: (316) 946-4155; fax: (316) 946-4107.

**SUPPLEMENTARY INFORMATION:**

**Discussion**

On March 5, 2007, we issued AD 2007-06-01, Amendment 39-14982 (72 FR 10909, March 12, 2007), to supersede AD 62-24-01. AD 2007-06-01 retained inspections of the front and rear horizontal stabilizer spars for cracks, but changed the inspection method from the dye penetrant method to the surface eddy current method.

We inadvertently left out the language in AD 2007-06-01 that required replacement of any horizontal stabilizer spar found cracked prior to further flight although the procedures in the appendix made reference to corrective action. The replacement information was contained in the NPRM.

Consequently, the FAA sees a need to clarify AD 2007-06-01 to assure that any cracked horizontal stabilizer spar is replaced prior to further flight.

**Correction of Publication**

This document clarifies AD 2007-06-01 by incorporating the replacement language that was proposed in the NPRM and adds the amendment to section 39.13 of the Federal Aviation Regulations (14 CFR 39.13).

Since this action only clarifies the intent of what was originally proposed in the NPRM, it has no adverse economic impact and imposes no additional burden on any person than was already proposed. Therefore, the FAA has determined that prior notice and opportunity for public comment are unnecessary.

**List of Subjects in 14 CFR Part 39**

Air transportation, Aircraft, Aviation safety, Safety.

**Adoption of the Amendment**

Accordingly, under the authority delegated to me by the Administrator, the Federal Aviation Administration amends part 39 of the Federal Aviation Regulations (14 CFR part 39) as follows:

**PART 39—AIRWORTHINESS DIRECTIVES**

1. The authority citation for part 39 continues to read as follows:

**Authority:** 49 U.S.C. 106(g), 40113, 44701.

**§ 39.13 [Amended]**

2. The FAA amends § 39.13 by removing Airworthiness Directive (AD) 2007-06-01, Amendment 39-14982 (72 FR 10909, March 12, 2007), and adding the following new AD:

**2007-06-01 R1 Raytheon Aircraft Company:** Amendment 39-15016; Docket No. FAA-2006-25105; Directorate Identifier 2006-CE-33-AD.

**Effective Date**

(a) This AD becomes effective on April 16, 2007.

**Affected ADs**

(b) This AD revises AD 2007-06-01, Amendment 39-14982, which superseded AD 62-24-01, Amendment 39-508.

**Applicability**

(c) This AD affects the following airplane models and serial numbers that are certificated in any category:

Model	Serial Nos.
Beech 45 (YT-34) .....	All.
Beech A45 (T34A, B-45) .....	All.
Beech D45 (T-34B) .....	All.

**Unsafe Condition**

(d) This AD is intended to prevent failure of the front and/or rear horizontal stabilizer spars caused by fatigue cracks by changing the inspection method from dye penetrant to surface eddy current. This failure could result in stabilizer separation and loss of control of the airplane.

**Compliance**

(e) Using the surface eddy current inspection procedures outlined in the appendix of this AD, inspect the front and rear horizontal stabilizer spars between the butt rib and the inboard end for cracks, unless already done, as presented below. If any crack is found in either spar or the reinforcing doubler during any inspection required by this AD, prior to further flight, replace the stabilizer and continue to repetitively inspect at intervals not to exceed 500 hours time-in-service (TIS).

(1) *If the last inspection of the front and rear horizontal stabilizer spars was done using the surface eddy current method (or FAA-approved equivalent method) to show compliance with AD 62-24-01 and/or to show compliance with the alternative method of compliance (AMOC) to AD 2004-25-51:* Repetitively inspect thereafter at intervals not to exceed 500 hours TIS.

(2) *If the last inspection of the front and rear horizontal stabilizer spars required by AD 62-24-01 was done using the dye penetrant method:* Inspect initially as presented in the table below and repetitively thereafter at intervals not to exceed 500 hours TIS:

If	Then
(i) Less than 200 hours TIS have passed since the last inspection required by AD 62-24-01:	Inspect at whichever of the following occurs later: (A) Upon accumulating 200 hours TIS since the last inspection required by AD 62-24-01; or (B) Within the next 6 months after April 16, 2007 (the effective date of this AD).
(ii) 200 hours TIS or more have passed since the last inspection required by AD 62-24-01:	Inspect at whichever of the following occurs first, unless paragraph (e)(2)(iii) of this AD applies, as specified below: (A) At the next repetitive inspection required by AD 62-24-01; or (B) Within the next 6 months after April 16, 2007 (the effective date of this AD).
(iii) Paragraph (e)(2)(ii) results in the initial surface eddy current inspection becoming mandatory within 30 days after the effective date of this AD:	Inspect within the next 30 days after April 16, 2007 (the effective date of this AD).

**Alternative Methods of Compliance (AMOCs)**

(f) The Manager, Wichita Aircraft Certification Office, FAA, ATTN: T.N. Baktha, Aerospace Engineer, 1801 Airport Road, Mid-Continent Airport, Wichita, Kansas 67209; telephone: (316) 946-4155; fax: (316) 946-4107, has the authority to approve AMOCs for this AD, if requested using the procedures found in 14 CFR 39.19.

(g) AMOCs approved for AD 62-24-01 are approved for this AD.

**Appendix to AD 2007-06-01 R1—Surface Eddy Current Inspection Procedure**

*Note: This surface eddy current inspection procedure is based on T-34 Spar Corporation TSC 3506, Rev C, dated May 10, 2005. The T-34 Spar Corporation is allowing the use of this procedure to be included in this Airworthiness Directive. Alternative methods of compliance procedures will be allowed, if approved by the Wichita Aircraft*

*Certification Office and requested using the procedures found in 14 CFR 39.19.*

**Purpose**

This procedure is to be used to detect cracks in the inner and outer spars of the front and rear spar assemblies of Raytheon Aircraft Company Beech Models 45 (YT-34), A45 (T-34A, B-45), and D45 (T-34B) airplane stabilizers outside of the steel bushings in the attach holes.

**Area To Be Inspected**

To access the area of inspection, remove the stabilizer from the airplane. The areas to be inspected include the forward and aft surfaces of the inner and outer front and rear spars of the horizontal stabilizers in the areas surrounding each of the attach holes.

**Preparing the Area for Inspection**

Thoroughly clean area to be inspected with solvent (acetone or equivalent) as required until no signs of dirt, grime, or oil remain on the front and rear spars from the closeout former inboard on the forward and aft surfaces of the spars.

Surfaces to be inspected should be smooth and corrosion-free. Any loss of thickness due to corrosion below material thickness tolerance is cause for rejection of the structure. An ultrasonic tester may be used to determine if material thickness has been compromised.

**Equipment Requirements**

Nortec Stavely 2000D Eddy Current Tester or equivalent.

*Probe:* 50–500 KHz, shielded, absolute, 0.071" diameter (0.090 max. diameter), right angle, pencil style, surface probe, 5" long, drop or equivalent. Use 0.025" notch (beyond head) for calibration.

**Personal Requirements**

Technicians with Eddy Current, Level II or Level III per one of the following specifications: ATA specification 105, SNT-TC-1A, or NAS-410 (MIL-std 410E).

**Methods**

Typical Set-up Parameters:  
Frequency – 350 KHz, Gain Vertical – 75 dB, Horizontal – 69 dB, Drive-Mid, Filters-Lo Pass-30, Hi Pass-0, Lift off-Horizontal to the left, adjust as required. The most reliable indication (minimum of 1/2 to 2 graticules) of the smallest observable flaw in the coupon (see the attached Figures) occurs from the notch extending 0.025" past the edge of the nominal fastener head (total notch length of 0.100" from the edge of the nominal hole). Install appropriate aluminum guide pin into bushing such that the edge of the guide pin

is flush with the edge of the bushing. Using the pin (see the attached Figures) as a guide, circle the area surrounding the steel bushing with the probe and adjacent area (approximately 1/4") to inspect for cracks. Inspect forward and aft surfaces surrounding bushings of each spar.

**Note:** T-34 Spar Corporation, 2800 Airport Road, Hanger A, Ada, Oklahoma 74820 is a source for these coupons and pin.

**Accept/Reject Criteria**

Any repeatable flaw indication is cause for rejection in accordance with the procedure. In the event that any crack is detected, describe the flaw in detail providing sketch as needed and send the information to the Wichita ACO.

**Documentation Requirements**

Record inspection findings in the aircraft logbook.

THE INFORMATION CONTAINED IN THIS DRAWING IS THE SOLE PROPERTY OF GENERAL AVIATION MODIFICATIONS, INC. ANY REPRODUCTION IN PART OR WHOLE WITHOUT THE WRITTEN PERMISSION OF GAMI IS PROHIBITED.

REVISIONS			
REV	DESCRIPTION	DATE	APPROVED
A	CHANGED TO BE MADE INTO TWO SEPERATE PARTS	3-18/05	D. LANDRETH

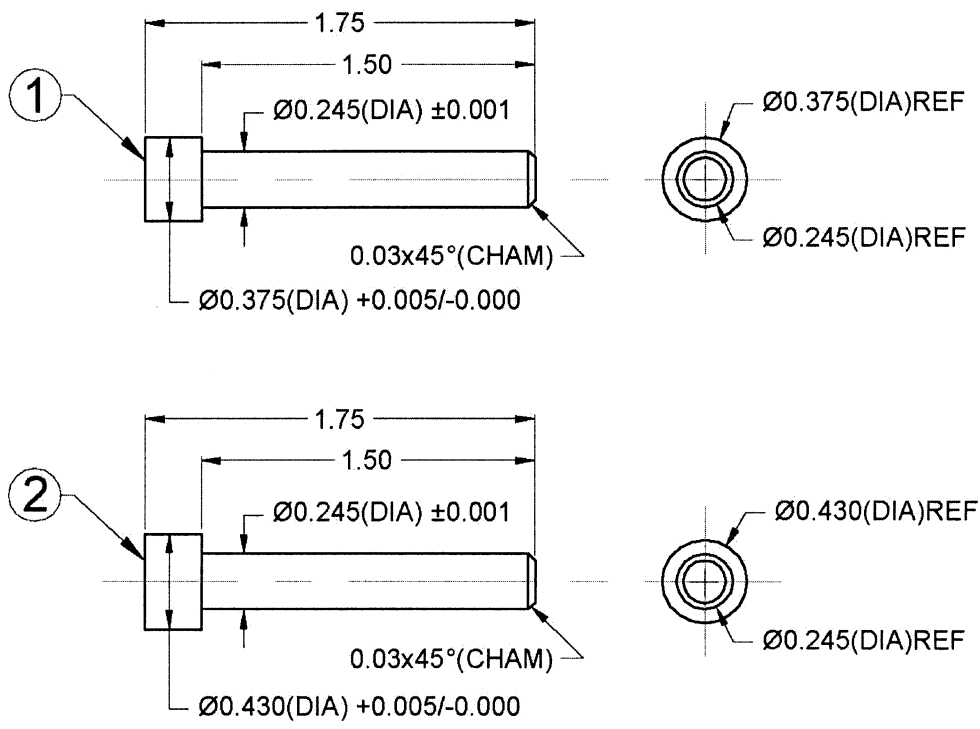

KEY	PART NO.	DESCRIPTION	SIZE	MATERIAL SPEC.	HEAT TREAT	NOTES
2	45-127-2	BUSHING TOOL	Ø0.44(DIA) x1.75	ALUMINUM		BREAK ALL SHARP EDGES
1	45-127-1	BUSHING TOOL	Ø0.38(DIA) x1.75	ALUMINUM		BREAK ALL SHARP EDGES

DIMENSIONING AND TOLERANCING IN INCHES UNLESS OTHERWISE SPECIFIED  ANGLES ± 2° DECIMALS XX ± .01 DECIMALS XXX ± .005 RIVET & BOLT EDGE MARGIN ± .05 BEND RADII ± .01 ON .03 & .05 ± .03 ON .09 & GREATER FRACTIONS ± 1/16 SURFACE ROUGHNESS 63RMS OR BETTER	CAD GENERATED DRAWING. DO NOT MANUALLY UPDATE		<b>GENERAL AVIATION MODIFICATIONS, INC.</b> 2800 AIRPORT ROAD, HANGAR A ADA, OKLAHOMA 74820						
	APPROVALS	DATE							
	DRAWN	LUKE KERR	3-14/05	PROBE LOCATING, BUSHING TOOL					
	CHECKED								
RESP'NG									
MFG'NG			SIZE	DWG. NO					
QUAL'NG			A	45-127					
DIMENSIONS AND SURFACE TEXTURE DESIGNATIONS APPLY BEFORE PLATING OR FINISH COATING UNLESS OTHERWISE NOTED		SCALE	1.5=1	CAD FILE	45-127 REVA.DWG	REV	A	SHEET	1 OF 1

Figure 1

THE INFORMATION CONTAINED IN THIS DRAWING IS THE SOLE PROPERTY OF GENERAL AVIATION MODIFICATIONS, INC. ANY REPRODUCTION IN PART OR WHOLE WITHOUT THE WRITTEN PERMISSION OF GAMI IS PROHIBITED.

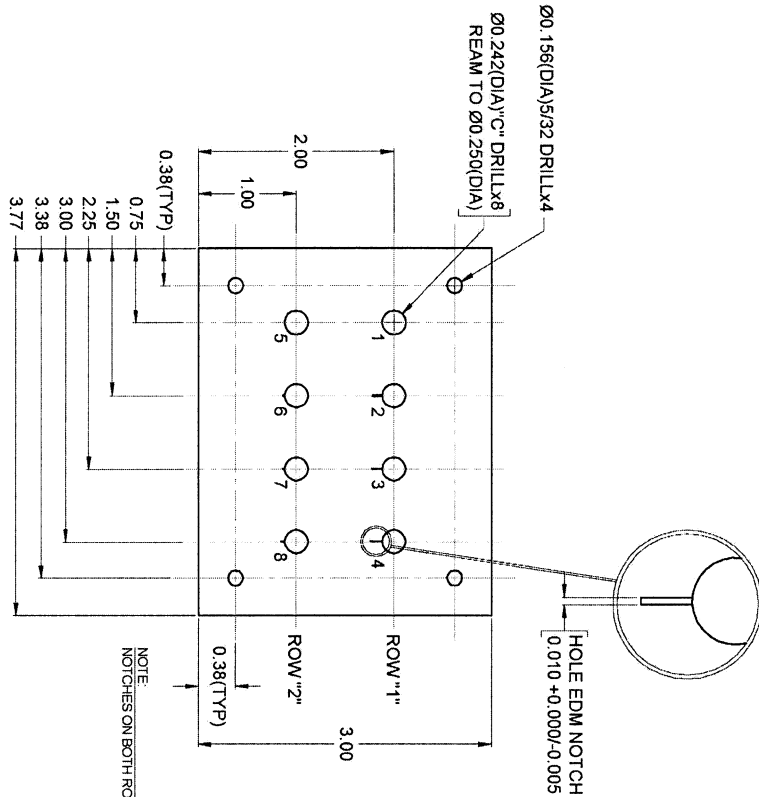

\*NOTE: HOLE 1, A = 0.000 (NO NOTCH)  
 HOLE 2, A = 0.095 ±0.001  
 HOLE 3, A = 0.105 ±0.001  
 HOLE 4, A = 0.115 ±0.001  
 HOLE 5, A = 0.000 (NO NOTCH)  
 HOLE 6, A = 0.014 ±0.001  
 HOLE 7, A = 0.024 ±0.001  
 HOLE 8, A = 0.034 ±0.001

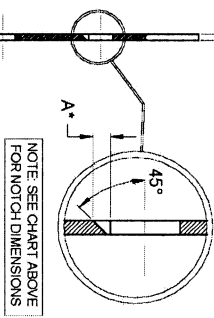

NOTE: NOTCHES ON BOTH ROW "1" AND ROW "2" ARE 45° TO HOLES(S)

REVISIONS		
REV.	DESCRIPTION	DATE APPROVED
A	CHANGED DRILL HOLES #8 FROM LETTER "D" TO LETTER "C"	3-JUN-07 1 INCH

45-128-1	TEST COUPON	3.00x 7"	2024 ALUMINUM	TS	BREAK ALL SHARP EDGES
PART NO.	DESCRIPTION	SIZE	MATERIAL SPEC.	HEAT TREATMENT	NOTES
45-128-1	TEST COUPON	3.00x 7"	2024 ALUMINUM	TS	BREAK ALL SHARP EDGES
DESIGNED BY	APPROVED BY	DATE			
LUKE KERR	LUKE KERR	3-28-05			
GENERAL AVIATION MODIFICATIONS, INC. 2000 AIRPORT ROAD, TULSA, OK 74116 918-439-1111					
COUPON					
REV. 1	DATE	BY	APPROVED BY	DATE	BY
B	45-128-1	3-28-05	LUKE KERR	3-28-05	A

Figure 2

THE INFORMATION CONTAINED IN THIS DRAWING IS THE SOLE PROPERTY OF GENERAL AVIATION MODIFICATIONS, INC. ANY REPRODUCTION IN PART OR WHOLE WITHOUT THE WRITTEN PERMISSION OF GAMI IS PROHIBITED.

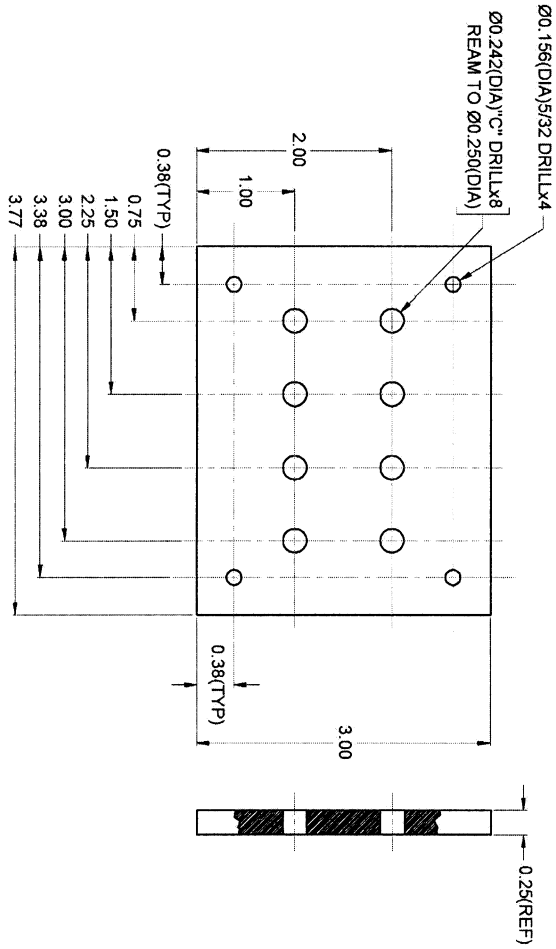

REVISIONS			DATE	APPROVED
REV.	DESCRIPTION	BY		
A	CHANGED DRILL HOLES 8 FROM LETTER 'C' TO LETTER 'C°'		3/30/05	T. FORDA

45-128-2	TEST COUPON	3.00x3.77	MILD STEEL	BREAK ALL SHARP EDGES
PART NO.	DESCRIPTION	SIZE	MATERIAL SPEC.	HEAT TREATMENT
45-128-2	TEST COUPON	3.00x3.77	MILD STEEL	BREAK ALL SHARP EDGES
DESIGNED BY	DATE	APPROVED	NOTES	
LUKE KERR	3-22-05	LUKE KERR	COUPON	
GENERAL AVIATION MODIFICATIONS, INC.	2800 W. WATSON ROAD, WYOMING, WY 83091			
SCALE	AS SHOWN			
45-128-2	45-128-2			SHEET 1 OF 4

Figure 3

THE INFORMATION CONTAINED IN THIS DRAWING IS THE SOLE PROPERTY OF GENERAL AVIATION MODIFICATIONS, INC. ANY REPRODUCTION IN PART OR WHOLE WITHOUT THE WRITTEN PERMISSION OF GAMI IS PROHIBITED.

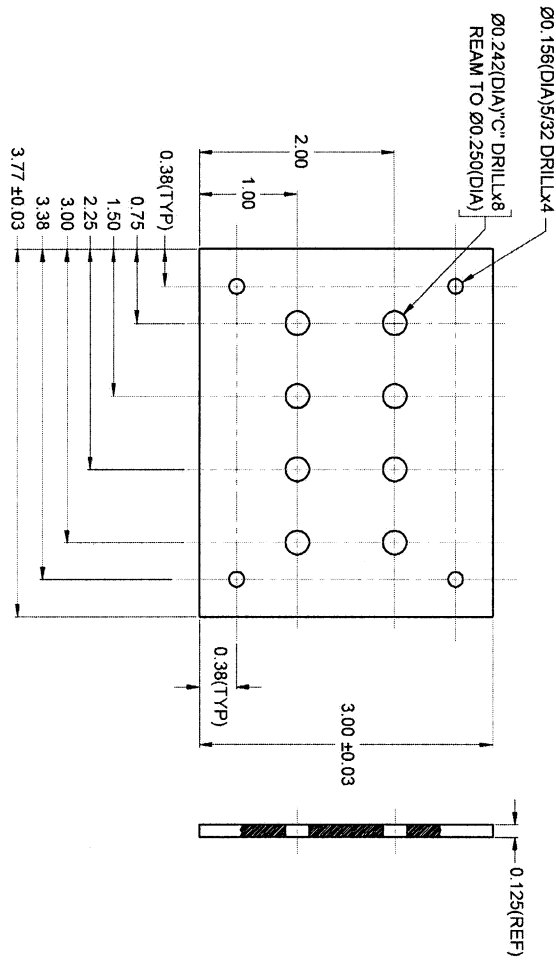

REVISIONS			
REV.	DESCRIPTION	DATE	APPROVED
A	CHANGED DRILL HOLES #8 FROM LETTER 'C' TO LETTER 'C'	3.2005	T. ROGAL

45-128-3	TEST COUPON	3.90x77	3024 ALUMINUM	T3	BREAK ALL SHARP EDGES
PART NO.	DESCRIPTION	SIZE	MATERIAL SPEC.	HEAT TREATMENT	NOTES
QTY	QTY REQUIRED	QTY ORDERED	QTY RECEIVED	QTY ON HAND	QTY IN PROCESS
1	1	1	1	1	1
GENERAL AVIATION MODIFICATIONS, INC. 2800 AIRPORT ROAD, SUITE 400 FORT WORTH, TEXAS 76116 PHONE: (817) 741-1000 FAX: (817) 741-1001 WWW: WWW.GAMIMODS.COM DRAWING: 45-128-3 REV. 01 DATE: 3-22-05 DRAWN: L. KERR CHECKED: L. KERR APPROVED: L. KERR DO NOT SCALE DRAWING COUPON 45-128-3 SHEET 1 OF 4					

Figure 4

THE INFORMATION CONTAINED IN THIS DRAWING IS THE SOLE PROPERTY OF GENERAL AVIATION MODIFICATIONS, INC. ANY REPRODUCTION IN PART OR WHOLE WITHOUT THE WRITTEN PERMISSION OF GAMI IS PROHIBITED.

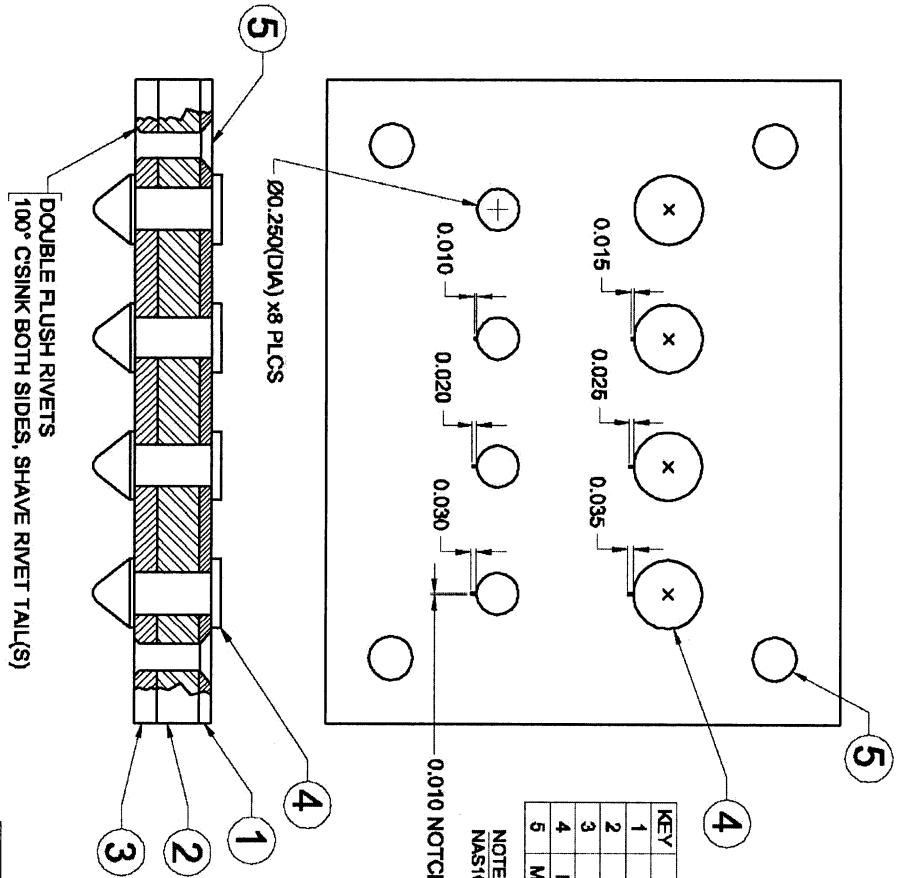

KEY	P/N	DESCRIPTION	QTY.
1	45-128-1	COUPON (0.071) 2024-T3	1
2	45-128-2	COUPON (0.250) STEEL	1
3	45-128-3	COUPON (0.125) 2024-T3	1
4	NAST1054-8-8	PIN	4
5	MS20426AD5-8	RIVET	4

NOTE:  
NAS1054-8-8 FASTENERS IN PLACE IN TOP ROW ONLY

REVISIONS		
REV.	DESCRIPTION	DATE

DIMENSIONS AND TOLERANCES IN INCHES UNLESS OTHERWISE SPECIFIED ANGLES ± 1° UNLESS OTHERWISE SPECIFIED DECIMALS 20 ± 0.005 FRACTIONS 32 ± 0.001 HOLE & NOTCH DIMENSIONS ± 0.005 HOLE & NOTCH DIMENSIONS ± 0.005 1.250 IN. AS A LIMITING DIMENSION UNLESS OTHERWISE SPECIFIED DIMENSIONS UNLESS OTHERWISE SPECIFIED		C/O GENERATED DRAWING, DO NOT MANUALLY EDIT APPROVALS DATE 3-29-05 LANCE HERRIG	
GENERAL AVIATION MODIFICATIONS, INC. 2900 LAKE CREST ROAD, JACOBUS, IA 50501-0001 515-233-1100		COUPON ASSEMBLY PART NO. 45-128 DRAWING NO. 45-128 REV/C/DWG SHEET 1 OF 4	

Figure 5



Issued in Kansas City, Missouri, on March 30, 2007.

**James E. Jackson,**

*Acting Manager, Small Airplane Directorate, Aircraft Certification Service.*

[FR Doc. 07-1715 Filed 4-5-07; 8:45 am]

BILLING CODE 4910-13-P

## DEPARTMENT OF TRANSPORTATION

### Federal Aviation Administration

#### 14 CFR Part 39

[Docket No. FAA-2007-27687; Directorate Identifier 2000-NE-42-AD; Amendment 39-15012; AD 2007-07-07]

RIN 2120-AA64

#### Airworthiness Directives; General Electric Company CF34-1A, -3A, -3A1, -3A2, -3B, and -3B1 Turbofan Engines

**AGENCY:** Federal Aviation Administration (FAA), Department of Transportation (DOT).

**ACTION:** Final rule; request for comments.

**SUMMARY:** The FAA is superseding an existing airworthiness directive (AD) for General Electric Company (GE) CF34-1A, -3A, -3A1, -3A2, -3B, and -3B1 turbofan engines. That AD requires a onetime inspection of certain fan disks for electrical arc-out indications, replacing fan disks with electrical arc-out indications, and reducing the life limit of certain fan disks. This AD requires the same reduced life limit of certain fan disks, but requires on-wing inspection of certain fan disks installed on regional jets within 500 flight hours after the effective date of this AD. This AD also requires more enhanced shop-level inspections of all fan disks for electrical arc-out defects. This AD results from a report that in January 2007, a CF34-3B1 turbofan engine experienced an uncontained fan disk failure during flight operation. We are issuing this AD to prevent an uncontained fan disk failure and airplane damage.

**DATES:** Effective April 23, 2007. The Director of the Federal Register approved the incorporation by reference of certain publications listed in the regulations as of April 23, 2007.

We must receive any comments on this AD by June 5, 2007.

**ADDRESSES:** Use one of the following addresses to comment on this AD.

- *DOT Docket Web site:* Go to <http://dms.dot.gov> and follow the instructions for sending your comments electronically.

- *Government-wide rulemaking Web site:* Go to <http://www.regulations.gov>

and follow the instructions for sending your comments electronically.

- *Mail:* Docket Management Facility; U.S. Department of Transportation, 400 Seventh Street, SW., Nassif Building, Room PL-401, Washington, DC 20590-0001.

- *Fax:* (202) 493-2251.

- *Hand Delivery:* Room PL-401 on the plaza level of the Nassif Building, 400 Seventh Street, SW., Washington, DC, between 9 a.m. and 5 p.m., Monday through Friday, except Federal holidays.

Contact General Electric Company via Lockheed Martin Technology Services, 10525 Chester Road, Suite C, Cincinnati, Ohio 45215; telephone (513) 672-8400; fax (513) 672-8422, for the service information identified in this AD.

**FOR FURTHER INFORMATION CONTACT:** Tara Chaidez, Aerospace Engineer, Engine Certification Office, FAA, Engine and Propeller Directorate, 12 New England Executive Park, Burlington, MA 01803; e-mail: [tara.chaidez@faa.gov](mailto:tara.chaidez@faa.gov); telephone (781) 238-7773; fax (781) 238-7199.

**SUPPLEMENTARY INFORMATION:** On February 24, 2006, the FAA issued AD 2006-05-04, Amendment 39-14501 (71 FR 10832; March 3, 2006). That AD requires a onetime inspection, and if necessary replacement of certain fan disks for electrical arc-out defects. That AD also reduces the life limit of certain fan disks. That AD was the result of a fan disk crack found during a visual inspection as part of routine engine maintenance. That condition, if not corrected, could result in an uncontained failure of the engine.

#### Actions Since AD 2006-05-04 was Issued

Since that AD was issued, a CF34-3B1 turbofan engine experienced an uncontained fan disk failure during flight operation, in January 2007. An inspection of the recovered segments of the fan disk found an electrical arc-out defect at the fracture origin site. The fan disk was marked using the electrochemical etch marking (ECM) procedure during engine assembly. If the ECM procedure is performed incorrectly, an arc-out defect can occur. This arc-out defect, caused during part marking, resulted in the uncontained failure.

The uncontained fan disk failure during flight operation in January 2007 showed that the inspections in GE Service Bulletin No. CF34-BJ 72-A0088, Revision 1, dated October 30, 2000 and in GE Alert Service Bulletin (ASB) No. CF34-AL 72-A0103, dated August 4, 2000, mandated by AD 2006-05-04, are not adequate to find all electrical arc-out defects.

We issued emergency AD 2007-04-51 on February 16, 2007, and its follow-up

published version, AD 2007-05-16, on February 28, 2007, to perform an enhanced onetime inspection of a high-risk suspect population of 31 fan disks. While complying with those ADs, operators found indications of additional electrical arc-out defects.

Because these additional indications of electrical arc-out defects validate our concern for the significant risk posed in the remaining suspect population of fan disks, we are issuing this final rule; request for comments AD. This AD requires an accelerated inspection schedule using the improved inspections of the three GE ASBs listed below. These ASBs include fluorescent penetrant inspection (FPI), tactile and enhanced visual (TEV) inspection, and eddy current inspection (ECI) for finding electrical arc-out defects. This condition, if not corrected, could result in an uncontained fan disk failure and airplane damage.

#### Relevant Service Information

We have reviewed and approved the technical contents of GE ASBs No. CF34-BJ S/B 72-A0212, Revision 2, dated March 22, 2007, ASB No. CF34-AL S/B 72-A0233, Revision 2, dated March 22, 2007, and ASB No. CF34-AL S/B 72-A0231, dated March 7, 2007. All three ASBs list the affected fan disks by serial number and part number. The first two ASBs describe procedures for performing FPI, a tactile and TEV inspection, and ECI for cracks and electrical arc-out defects. The third ASB describes procedures for performing an on-wing TEV inspection of fan disks for electrical arc-out defects.

#### FAA's Determination and Requirements of This AD

The unsafe condition described previously is likely to exist or develop on other GE CF34-1A, -3A, -3A1, -3A2, -3B, and -3B1 turbofan engines of the same type design. We are issuing this AD to prevent an uncontained fan disk failure and airplane damage. This AD requires on-wing TEV inspection of fan disks for electrical arc-out defects on fan disks installed on regional jets within 500 flight hours after the effective date of this AD. This AD also requires for all affected fan disks shop-level FPI, enhanced TEV, and ECI inspections for cracks and electrical arc-out defects. This AD also carries forward from AD 2006-05-04 the reduced life limit for certain fan disks. You must use the service information described previously to perform the actions required by this AD.