

DEPARTMENT OF TRANSPORTATION**National Highway Traffic Safety Administration****49 CFR Parts 564 and 571**

Docket No. NHTSA-2007-28322

RIN 2127-AJ75

Federal Motor Vehicle Safety Standards; Lamps, Reflective Devices, and Associated Equipment

AGENCY: National Highway Traffic Safety Administration (NHTSA), Department of Transportation.

ACTION: Final Rule.

SUMMARY: This document amends the Federal Motor Vehicle Safety Standard (FMVSS) No. 108 on lamps, reflective devices, and associated equipment by reorganizing the regulatory text so that it provides a more straightforward and logical presentation of the applicable regulatory requirements, which includes the agency's interpretation of the existing requirements. It also greatly reduces the need to consult relevant third-party standards by including applicable requirements directly into the main body of Standard No. 108, rather than incorporating such provisions by reference. This final rule does not impose any new substantive requirements on manufacturers.

In addition, this document amends 49 CFR Part 564, *Replaceable Light Source Information*, by adding a newly created Appendix C, which relocates figures addressing sealed beam headlamps that currently reside in FMVSS No. 108 and a relevant Society of Automotive Engineers (SAE) standard there. We believe few lighting manufacturers still produce sealed beam headlamps, and their diminishing use is unlikely to draw new manufacturers of this type of lamp. Accordingly, we see no drawbacks to consolidating the information regarding sealed beam light sources with other light source information currently located in 49 CFR Part 564.

DATES: *Effective date:* The final rule is effective September 1, 2008 with voluntary early compliance permitted immediately. The incorporation by reference of certain publications listed in the rule is approved by the Director of the Federal Register as of September 1, 2008. *Petitions for reconsideration:* Petitions for reconsideration of this final rule must be received not later than January 18, 2008.

ADDRESSES: Any petitions for reconsideration should refer to the docket number of this document and be

submitted to: Administrator, National Highway Traffic Safety Administration, 1200 New Jersey Avenue, SE., West Building, Ground Floor, Docket Room W12-140, Washington, DC 20590.

FOR FURTHER INFORMATION CONTACT: For technical issues: David Hines, Office of Crash Avoidance Standards (NVS-121), NHTSA, 1200 New Jersey Avenue, SE., West Building, Washington, DC 20590 (Telephone: (202) 493-0245) (Fax: (202) 366-7002).

For legal issues: Ari Scott, Office of the Chief Counsel (NCC-112), NHTSA, 1200 New Jersey Avenue, SE., West Building, Washington, DC 20590 (Telephone: (202) 366-2992) (Fax: (202) 366-3820).

SUPPLEMENTARY INFORMATION:**Table of Contents**

- I. Executive Summary
- II. Background
 - A. Historical Overview of the Standard
 - B. The Need for an Administrative Rewrite of the Standard
- III. December 2005 Notice of Proposed Rulemaking (NPRM) and Public Comments
 - A. The NPRM
 - B. Discussion of Public Comments Received in Response to the NPRM and Their Impact on the Final Rule
 - (a) 49 CFR Part 564
 - (b) 49 CFR Part 571.108
 - 1. Administrative Considerations
 - 2. Omissions, Typographical Errors, and Inconsistent Language
 - 3. Organization of the Standard
 - 4. Suggestions Beyond the Scope of the Rewrite
 - 5. Suggestions Within the Scope of the Rewrite
- IV. The Final Rule
 - A. 49 CFR Part 564
 - B. 49 CFR Part 571.108
- V. Benefits and Costs
- VI. Rulemaking Analyses and Notices
 - Appendix A: FMVSS No. 108 Rewrite Cross Reference
 - Appendix B: FMVSS No. 108 Rewrite Cross Reference
 - Appendix C: List of figures

I. Executive Summary

After carefully considering the public comments on its December 2005 proposal, the agency has decided to adopt a final rule amending Federal Motor Vehicle Safety Standard (FMVSS) No. 108, *Lamps, Reflective Devices, and Associated Equipment*, by reorganizing the regulatory text and directly importing requirements from applicable SAE standards currently incorporated by reference into the regulatory text. In doing so, the agency has decided to make some changes from the NPRM, including modifying the organizational structure of the standard, relocating test procedures and performance requirements from attached tables to the

regulatory text, and incorporating the substance of several additional interpretations into the standard. In addition, three SAE documents that the agency had proposed to continue to be incorporated by reference in the NPRM have now been integrated into the regulatory text, and the location of marking requirements within the standard has been further consolidated.

Consistent with the NPRM, the final rule also establishes an Appendix C in 49 CFR Part 564, *Replaceable Light Source Information*, as a repository for dimensional and electrical information associated with standardized sealed beam headlamps that currently resides in figures in FMVSS No. 108.

These modifications have furthered the objective of this rewrite by increasing clarity as follows: (1) Making requirements easier to find and comprehend; (2) presenting performance requirements and test procedures together through the inclusion of relevant provisions of third-party documents (previously incorporated by reference) directly into the regulatory text of the standard; and (3) updating Standard No. 108 to reflect significant letters of interpretation. The rewrite of FMVSS No. 108 is considered administrative in nature because the standard's existing requirements and obligations are not being increased, decreased, or substantively modified. Accordingly, costs associated with manufacturer compliance with Standard No. 108 are not expected to change as a result of this regulatory action.

II. Background*A. Historical Overview of the Standard*

On December 30, 2005, NHTSA published a notice of proposed rulemaking¹ (NPRM) to amend FMVSS No. 108, *Lamps, Reflective Devices, and Associated Equipment*, by reorganizing the regulatory text so that it provides a more straight-forward and logical presentation of the applicable regulatory requirements. The initial version of FMVSS No. 108 was adopted almost 40 years ago to increase motor vehicle safety by establishing minimum requirements for vehicle lighting, reflective devices, and associated equipment. In developing the standard, NHTSA incorporated requirements from a number of industry consensus standards, in particular SAE standards. At that time, motor vehicle technologies were relatively simple, as compared to today's designs. For example, motor vehicle headlighting systems were limited to ones consisting of either two

¹ 70 Fr 77454, (Dec. 30, 2005) (Docket No. NHTSA-2006-23634-3).

7-inch or four 5¾-inch round sealed beam units. During the ensuing years, a number of rectangular sealed beam units, replaceable bulb headlamps, and integral beam headlamps were developed, and FMVSS No. 108 was amended to permit the use of these new technologies. Later, the standard was further amended to add requirements for high-mounted stop lamps, side marker lamps, and side reflex reflectors, to allow for daytime running lamps, and to address the conspicuity needs of large vehicles.

However, such amendments were made on an *ad hoc* basis, which, over time, resulted in a patchwork organization for FMVSS No. 108. Furthermore, when regulated parties had questions regarding how FMVSS No. 108 should be interpreted (in many instances due to rapid advances in lighting technology not fully anticipated or addressed by the existing regulatory text), they submitted requests for interpretation to the agency on specific issues. Since its promulgation, a large number of interpretation letters have been issued pertaining to Standard No. 108. Thus, in its current state, FMVSS No. 108 has requirements that are located directly in its regulatory text, located in referenced and sub-referenced SAE standards, and elaborated upon in various agency interpretations. Since its inception, NHTSA has never completed a thorough reorganization of the entire standard.

B. The Need for an Administrative Rewrite of the Standard

Due to concerns about being able to locate requirements efficiently and the apparent lack of clarity associated with the standard (as demonstrated by an abundance of letters of interpretation), we decided to undertake an administrative rewrite of FMVSS No. 108. The agency has also received complaints that the current text of FMVSS No. 108 sometimes results in confusion, in part due to the way it is organized. Regulated parties have stated that the current organization of FMVSS No. 108 makes it difficult for them, at times, to be fully confident that all applicable requirements have been identified and satisfied prior to certification to the standard. Also, numerous interested parties have stated that the large number of interpretations that have been issued by the agency regarding Standard No. 108 make it difficult to locate and identify the agency's position on relevant issues. In addition, regulated parties have conveyed to the agency in recent years that some of the older versions of SAE standards incorporated by reference into

FMVSS No. 108 are no longer readily available from SAE International.

Throughout the past few decades, SAE has published revised, successor versions, with differing requirements, for many of their standards incorporated by reference into FMVSS No. 108. This appears to sometimes cause confusion on the part of regulated parties who, mistakenly, may believe that the most recent version of a SAE standard represents the regulatory requirement. The agency believes that interested parties should have easy access to the requirements of the standard, and, therefore, we believe there is value in publishing, without substantive change, applicable requirements that are currently contained in third-party documents directly within FMVSS No. 108 itself. The same logic applies to our decision to include the results of relevant legal interpretations in the standard. Furthermore, several provisions currently in Standard No. 108 refer to regulatory inception dates that are several years in the past, so the agency is eliminating text citing such past dates.

For these reasons, we believe that the benefits of an administrative rewrite of FMVSS No. 108 (e.g., making the standard more navigable and thereby facilitating compliance with existing requirements) justify the necessary commitment of agency resources to accomplish this reorganization of the standard.

III. December 2005 Notice of Proposed Rulemaking (NPRM) and Public Comments

A. The NPRM

As noted above, NHTSA published a NPRM on December 30, 2005 that proposed to reorganize FMVSS No. 108 to improve the clarity of the standard's requirements, thereby increasing its utility for interested parties. This administrative rewrite attempted to make the standard more understandable by adopting a simplified numbering scheme, to improve organization by grouping related materials in a more logical and consistent sequence, and to reduce reliance on references to third-party documents. As proposed, the reorganized standard progressed from vehicle-level requirements to device-level requirements, beginning with the most common requirements and then proceeding to exceptions.

The NPRM also proposed to move figures addressing sealed beam headlamps that are currently included in FMVSS No. 108 and SAE J1383 APR85, *Performance Requirements for Motor Vehicle Headlamps*, into 49 CFR

Part 564, *Replaceable Light Source Information*, as a newly created Appendix C. This modification would be consistent with the current practice of placing replaceable light source information in Part 564. The title of Part 564 would also be changed to "*Replaceable Light Source and Sealed Beam Headlamp Information*" to reflect the addition of the sealed beam headlamp content.

Whereas Standard No. 108 currently references approximately 35 different SAE documents in nearly 100 separate instances, the NPRM proposed reducing that number to eight documents, which were ones believed not to be routinely used by regulated parties. Accordingly, the NPRM proposed to incorporate the content of these frequently used SAE documents directly into the regulatory text and/or attached tables of Standard No. 108.

The proposed tables included Table I, which listed the required lamps and reflective devices for the various vehicles regulated by FMVSS No. 108. The number of required lamps and reflective devices, their color, their mounting locations and height above the road surface, and their manner of activation were included in Table I, which resembles an expanded version of Tables I through IV of the current FMVSS No. 108. Table II detailed the requirements for the four different kinds of headlighting systems permitted by the standard. Table III contained the conspicuity system requirements for large trucks and trailers, while Tables IV and V provided, respectively, effective projected luminous lens area requirements and visibility requirements. Tables VI through XII and XIV through XX listed photometric requirements for individual lamp types. Table XIII detailed the target locations for license plate lamp photometry. Table XXI contained test procedures and performance requirements for all associated devices. Finally Tables XXII and XXIII contained non-photometry test procedures and performance requirements for all lamps, reflective devices, replaceable light sources, and vehicle headlamp aiming devices (VHAD). In addition, several new figures were included to clarify some of the application requirements for conspicuity systems.

From a regulatory perspective, it was the agency's intention, as expressed in the NPRM, that the administrative rewrite of Standard No. 108 would neither result in any current obligation being diminished, nor any new obligation being imposed. In other words, the substantive requirements are identical to those of the current version

of FMVSS No. 108, including incorporated documents. Therefore, we do not believe that vehicle manufacturers and lighting manufacturers would have to make any changes to their respective products or production processes if the NPRM were made final.

B. Public Comments Received in Response to the NPRM

The agency received comments from twenty seven entities in response to the December 2005 NPRM, which were submitted by 11 lamp or lamp component manufacturers, 11 manufacturer or user associations, three vehicle manufacturers, and two test organizations. Commenters included: Truck Manufacturers Association (TMA), Motorcycle Industry Council (MIC), Koito Manufacturing Co., Ltd., (Koito), Truck Trailer Manufacturers Association (TTMA), General Electric Automotive Plastics (GE-Plastics), General Motors North America (GM), Specialty Equipment Market Association (SEMA), Grote Industries, L.L.C., (Grote), Innovative Lighting, Inc., Calcoast Industrial Testing Laboratory (Calcoast), General Electric Automotive Lighting (GE), Valeo Sylvania, L.L.C. (VS), Guide Corporation (Guide), Alliance of Automobile Manufacturers (AAM), 3M Traffic Safety Systems (3M), Valeo Lighting Systems (Valeo), Association of International Automobile Manufacturers (AIAM), Owner-Operator Independent Drivers Association, Inc. (OOIDA), Atlas Material Testing Solutions (Atlas), American Trucking Associations, Inc. (ATA), Honda Motor Co., LTD. (Honda), Nissan North America, Inc., (Nissan), and Bayer Material Science, L.L.C., (Bayer). A joint response was submitted by Motor and Equipment Manufacturers Association (MEMA), Transportation Safety Equipment Institute (TSEI), and Motor Vehicle Lighting Council (MVLIC), collectively the Associations (ASSN). Several months after the comment closing date the Associations submitted a supplementary response which was shortly followed by another supplementary response in conjunction with the Alliance (AAM/ASSN). All comments are available in Docket No. NHTSA-2006-23634 and were considered in the promulgation of this final rule.

The comments about the NPRM that we received can be divided into five general categories: (1) Administrative Considerations; (2) Omissions, Typographical Errors, and Inconsistent Language; (3) Organizational Structure; (4) Suggestions Beyond the Scope of the Rewrite; and (5) Suggestions Within the

Scope of the Rewrite. A summary and analysis of each issue identified is provided below.

(a) 49 CFR Part 564

We received only one substantive comment concerning the relocation of the sealed beam headlamp figures into a new Appendix C of Part 564 of this chapter. GE requested a separate NPRM for this purpose and that the drawings that would be filed in Appendix C be made available for review.

We stated in *Summary of the Proposal* in the NPRM that the final rule adopting the rewrite of Standard No. 108 would occur concurrently with the relocation of the sealed beam figures to Appendix C of Part 564. We also provided, at the end of that notice, a complete listing of all the figures and where they currently reside in FMVSS No. 108 or SAE J1383 APR85, which is incorporated by reference in the current version of FMVSS No. 108, but we did not provide specific regulatory text for Appendix C in the NPRM. Ample opportunity was provided for public comment on this issue, so we are making the establishment of Appendix C of Part 564 of this chapter and the transfer of the identified figures to it part of the final rule. We believe that it would be beneficial for the sealed beam drawings to be relocated as part of this reorganization so that applicable requirements are transferred in an accurate manner, thereby satisfying our commitment not to change the existing requirements of the standard.

(b) 49 CFR 571.108

1. Administrative Considerations

Some of the comments submitted in response to the NPRM were not focused upon the substance of the rewrite but rather addressed administrative concerns. Several commenters requested statements of reassurance that “* * * no substantive changes from existing requirements are intended,” and “* * * state that the existing body of interpretations is still valid.” On these points, we clarify as follows. First we reiterate that the administrative rewrite, as expressed in this final rule, does not make any substantive changes to the requirements of Standard No. 108. Furthermore, as stated in the NPRM, not all letters of interpretation were appropriate for inclusion into the regulatory language of FMVSS No. 108. Generally, we excluded those that we concluded did not add value to the regulatory text (i.e., one without broad applicability). However, all existing letters of interpretation, whether or not they are specifically integrated into the FMVSS No. 108 final rule, continue to

reflect the legal opinion of the agency unless they contradict the explicit regulatory text of the standard or were overturned by subsequent interpretations.

AAM suggested that the final rule should not be mandatory until September 1st, one year after publication of the final rule. We have established September 1, 2008 as the mandatory compliance date, with voluntary early compliance permitted immediately.

ATA, OOIDA, and TMA all expressed concern about conflicts between FMVSS No. 108 and the regulations of the Federal Motor Carrier Safety Administration (FMCSA). They requested that the rewrite of Standard No. 108 reconcile the differences that they perceive between it and the regulations of the FMCSA.

The FMCSA has established regulations for lamps, reflective devices, and associated equipment for commercial vehicles in use and a few specialized types of commercial vehicles at time of manufacture. The FMCSA made significant revisions to its lighting regulations in 2005² and some substantive differences do exist between the lighting regulations of FMCSA and FMVSS No. 108. These differences may have the potential to cause manufacturers of lamps and reflective devices that fall under the jurisdiction of both NHTSA and FMCSA to pursue different design, manufacturing, and compliance processes to satisfy the regulations of both agencies. However, any attempt at reconciliation here would be outside the scope of the rewrite process. Recently, FMCSA issued a final rule³ in response to a petition for reconsideration to its August 15, 2005 final rule, which resolved the differences between its regulations and FMVSS No. 108, as interpreted in NHTSA's July 28, 2005 interpretation to Mr. Clarke,⁴ concerning auxiliary lamps mounted near identification lamps. Regulated parties may want to consider other approaches to address the remaining differences between FMVSS No. 108 and 49 CFR Part 393. One such approach could be to submit rulemaking petitions to NHTSA and FMCSA requesting reconciliation of the differences between FMVSS No. 108 and 49 CFR Part 393.

² See 49 CFR Part 393, as last revised by 70 FR 48008 August 15, 2005 (Docket No. FMCSA-1997-2364-44).

³ 72 CFR 32011 (June 11, 2007) (Docket No. FMCSA 1997-2364).

⁴ <http://isearch.nhtsa.gov/files/GF002551.3.html>.

2. Omissions, Typographical Errors, and Inconsistent Language

Given the complexity of the proposed administrative rewrite of FMVSS No. 108, including the integration of the content of numerous SAE standards incorporated by reference into the regulatory text, some omissions and typographical errors occurred. Numerous comments were received identifying such occurrences. Accordingly, we have amended the regulatory text of the final rule to correct these errors.

Some respondents have noted instances where they believe that the language of the regulatory text used in the NPRM was not faithful to the language and intent of the current FMVSS No. 108. In many instances where a claim of unfaithful language was made in the comments, the agency adopted a conservative approach, choosing to revise the language of the NPRM back to that of the original document in the final rule. Where such a revision was not made, we have stated our reasons for that decision.

Two rather significant instances where contradictory regulatory language was found to exist in the current version of FMVSS No. 108 and its incorporated documents are discussed here. One has to do with the appropriate photometric requirement for a specific type of replaceable bulb headlamp and is discussed in detail in the section devoted to Table II. The other concerns the ratio between the stop lamp function and the taillamp function in a lamp where those functions are optically combined. The discussion related to Table IX contains an explanation of this issue. Both instances bolster our opinion that regulatory requirements should be stated once and only once in a document. Neither instance has ever generated an interpretation request nor did many respondents raise either issue in their comments to the docket. This reinforces our belief that, notwithstanding the existence of ambiguous regulatory language, the intent of the specific requirements was clear.

Because correction of either situation would require a substantive change to FMVSS No. 108, we have decided to refrain from addressing these examples now. However, we may issue a notice of correction in the near future to address what we believe are mistakes and inconsistencies that have existed for some time in Standard No. 108.

3. Organization of the Standard

The organizational structure of the reorganized standard, as presented in

the NPRM, progressed from vehicle-level requirements to device-level requirements, beginning with the most common requirements and then proceeding to exceptions. Requirements in the rewrite of FMVSS No. 108 are consolidated into dedicated paragraphs. Paragraphs S1 through S4 were organized in the same manner as the present standard. S4, *Definitions*, was expanded to incorporate relevant definitions from the applicable SAE standards previously incorporated as part of Standard No. 108. Paragraph S5 addressed the remaining references to SAE standards. Vehicle-level requirements were located in paragraph S6, including requirements by vehicle type. Following that, requirements were organized with dedicated sections for each type of lamp and reflective device, beginning with signal lamps, reflective devices and associated equipment under paragraph S7, and headlamp and headlighting requirements under paragraphs S8 through S13, and S16 through S18. Paragraph S14 addressed aimability performance requirements, while paragraph S15 contained requirements for replaceable light sources (including references to Part 564). In order to make requirements easier to find, a Table of Contents was added as an appendix to the standard.

The most detailed comments about the organizational structure of the standard were those in the supplementary response from the ASSN/AAM, which recommended a significantly different organizational structure that would divide the content of FMVSS No. 108 into four sections. Under the ASSN/AAM structure, the first section would contain general and specific lamp requirements, and the second section would consist of Tables I, II, III, VI, VII, VIII, IX, X, XI, XII, XIV, XV, XVI (split into three separate tables), XVII, XVIII, XIX, and XX. However, there would be some format changes to lamp photometry tables and the addition of graphical illustrations of photometric test points. These commenters similarly suggested three new tables that would graphically illustrate the required photometric test points, lines, and areas associated with upper beam headlamps, lower beam mechanically aimed headlamps, and lower beam visually/optically aimed headlamps. The third section would contain all the figures of the NPRM as well as Table XIII, *License Plate Lamp Target Locations*, redesigned as Figure 19. The fourth section would be subdivided into five annexes which would contain photometric test procedures and the physical test

procedures of Tables XXI, XXII, and XXIII.

ASSN/AAM also suggested dividing Table I into five separate tables: one for vehicles less than 80 in (2032 mm) in overall width, another for vehicles 80 in (2032 mm) or more in overall width, one for trailers, one for motorcycles, and one for school buses. The activation requirements would be removed from these tables and located in a new paragraph titled "*Electrical*." Tables IV and V covering projected luminous lens area and visibility would be eliminated and their requirements dispersed to the applicable individual lamp sections. These individual lamp sections would have a common format divided into 14 subsections representing specific requirements. An additional table would be created that would contain all marking requirements.

In consideration of the comments submitted by ASSN/AAM, we have decided to make significant changes to the structure of the standard presented in the NPRM. These structural changes include: (1) Relocating test procedures and performance requirements that were primarily contained in paragraph S6.8 and Tables XXI, XXII, and XXIII of the proposal, to paragraph S14 of the final rule; (2) expanding and standardizing the presentation of requirements in individual lamp and reflective device sections of the final rule beyond that of the proposal; (3) including the provisions from additional SAE documents, incorporated by reference in the proposal, in the regulatory text of the final rule; and (4) further consolidating the location of marking requirements in the final rule beyond that of the proposal.

We believe there is value in adopting a structure in the final rule that is easy for regulated parties to navigate. There were some aspects of the ASSN/AAM recommended structure that we did not adopt due to our effort to avoid redundancies, streamline the standard, and avoid adding new material not currently contained in Standard No. 108, including graphs, which could cause confusion. We believe that our approach in modifying the structure of the NPRM will collectively provide the most value to all end-users.

We have decided to adopt the ASSN/AAM recommendation regarding reorganization of the layout of several photometry requirement tables for reasons that follow. Standard No. 108 provides two alternative methods for demonstrating the photometric compliance of turn signal lamps, taillamps, stop lamps, backup lamps, parking lamps, and high-mounted stop lamps. For these lamps compliance can

be demonstrated by achieving a minimum photometric intensity at each of 18 to 22 discrete test points distributed within a pattern about 20° high and 40° wide centered about the H-V axis.⁵ Alternatively, FMVSS No. 108 also permits these specific lamps to demonstrate compliance by meeting a minimum photometric intensity for groups of these test points. Individual test points in proximity to each other are organized into groups consisting of from two to six points. The minimum photometric intensity requirement of each group is approximately (but not always exactly) the arithmetic sum of the minimum photometric intensities of all included points. This allows a lamp where one or more test point(s) in a group do not meet their individual minimum values to be compliant provided the remaining test points in the group exceed their minimum values by enough to allow the group total to exceed the group requirement.⁶ Turn signal lamps, taillamps, stop lamps, and parking lamps have five groups of test points; while backup lamps have six groups, and high-mounted stop lamps have four groups.

Tables VI, VII, VIII, IX, XII, XV, which detail photometry requirements for those lamps permitted to use both the individual test point and the grouped test point compliance methods, are formatted such that test points are organized in group order. Progressing from left to right horizontally, each test point group is identified by number, and then the individual test points included within that group are identified by their vertical and horizontal positions. Next, the minimum photometric intensity for each individual test point is shown, and finally, at the right end, the group minimum photometric intensity is shown.

In contrast, the photometry requirements tables suggested by the ASSN/AAM, and endorsed by Calcoast, organize the lamp test points in a vertical, then horizontal, manner that requires the user to search for each point to include in a group and then consult a sub-table to find out the minimum photometric requirement for that group. We find this suggested approach unnecessarily complex and prone to increasing, not decreasing, the possibility of error in determining photometric requirements. Therefore,

⁵ The pattern is wider for backup lamps and tighter for high mounted stop lamps.

⁶ No individual test point photometric intensity can fall below 60% of the point requirement when the group photometric method is used. In addition, photometric values between adjacent test points are regulated.

we have decided to retain the format of the photometric tables as presented in the NPRM with one simplification, which was to locate the horizontal and vertical test point positions in the same relative positions in each table.

Calcoast suggested, and we agree, that the horizontal test point positions and the vertical test point positions should always appear in the same columns. In our earlier proposal, this was not the case, and we have made modifications consistent with Calcoast's suggestion. The final rule designates the horizontal test point positions in a column to the left of a column that designates the corresponding vertical test point positions.

Nissan suggested that those lamps that are permitted to demonstrate photometric compliance by either the individual test point method or the grouped test point method have the required photometric intensity values for each individual test point reduced to 60 percent of the current requirement and only allow use of the grouped test point method. We did not adopt this suggestion because it would have reduced the number of compliance methods available to manufacturers, a substantive change beyond the scope of this administrative rewrite.

The original response from the ASSN, as well as the comments from Guide, suggested abandoning Tables XVIII and XIX and incorporating headlamp photometry requirements in a series of tables similar to the current FMVSS No. 108. We were not persuaded that more headlamp photometric tables would add value to the standard. Upper beam headlamp requirements are not related to whether a headlamp is mechanically or visually/optically aimed and six beam patterns adequately cover all headlamps. Many photometric test points are common to all lower beam headlamps. Tables XVIII and XIX present all required beam patterns (except for certain motorcycle headlamps) in a clear and concise format. Table II directs the user to the appropriate beam pattern in Tables XVIII and XIX. We retained this format for headlamp photometry requirements in the final rule.

Several commenters mentioned inconsistent use of a "no requirement" indicator where a test point appears in a photometry requirements table but there is no value required at that point. Our proposal used both a blank space and a N.R. notation. In the final rule, we have adopted a consistent indicator that there is no requirement for a test point. A dashed line (-) is used exclusively for this purpose in photometry requirements tables.

Commenters generally favored the use of tables in the NPRM for presenting performance requirements. However, Nissan, Grote, and TTMA all commented that Table I was too lengthy and should be separated into several sections based on common content. The Alliance suggested splitting Table XXIII into three separate tables because it contains tests for three distinctive items: (1) Headlamps, (2) vehicle headlamp aiming devices (VHAD), and (3) replaceable light sources. The differentiation of content in Table II of the NPRM was mentioned as being a particularly appropriate method of providing distinction.

Several commenters, including ASSN/AAM and Grote, noted that tables containing significant amounts of text, such as the test requirements in Tables XXI, XXII, and XXIII, would be difficult to use because of lengthy passages that contain several sentences and express several unique test conditions or requirements. We agree with these comments. The tabular format is best suited to displaying quantitative values or short textual requirements. In the final rule, we moved virtually all test procedures and performance requirements to S14, the last section of the standard. Specifically, the content of Table XXI of the NPRM has been moved to S14.9, *Associated Equipment Physical Test Procedures and Performance Requirements*, the content of Table XXII of the NPRM has been moved to S14.3, *Motorcycle Headlamp Out of Focus Test Procedures and Performance Requirements*, S14.4, *General Test Procedures and Performance Requirements* (consisting of the color test and plastic optical materials test), and S14.5, *Signal Lamp and Reflective Device Test Procedures and Performance Requirements*. In addition, the content of Table XXIII of the NPRM has been moved to S14.6, *Headlamp Physical Test Procedures and Performance Requirements*, S14.7, *Replaceable Light Source Physical Test Procedures and Performance Requirements*, and S14.8, *Vehicle Headlamp Aiming Devices (VHAD) Physical Test Procedures and Performance Requirements*.

General test procedures and performance requirements that were located in S6.8 of the NPRM have been placed in S14.1 of the final rule. Similarly, the photometric test procedures of S6.8 of the NPRM are now in S14.2 of the final rule.

In the final rule, we decided to split several of the tables into shorter, more distinctive, sections and we completely revised the content of Table III and Table XIII. Table I, *Required Lamps and*

Reflective Devices, is divided into three parts: (1) Table I-a for passenger cars, multipurpose passenger vehicles, trucks, and buses of all widths; (2) Table I-b for trailers, and (3) Table I-c for motorcycles. We decided upon sectioning Table I in this manner for several reasons. One is user diversity. Organizations that manufacture vehicles such as passenger cars, multipurpose passenger vehicles, trucks, and buses typically do not also manufacture trailers or motorcycles. Likewise, organizations that manufacture trailers typically do not manufacture self propelled vehicles, and those that manufacture motorcycles do not produce cars, trucks, or trailers. Some commenters suggested separate sections for narrow vehicles (less than 2032 mm in width) and wide vehicles (those 2032 mm or wider). However, several manufacturers produce both narrow and wide vehicles, sometimes as different optional versions of the same vehicle, such as pickup trucks.

Another consideration was commonality. Both narrow and wide vehicles are required to be equipped with a headlighting system, turn signal lamps, taillamps, stop lamps, side marker lamps, side and rear reflex reflectors, backup lamps and license plate lamps. Narrow vehicles are required to have parking lamps and high-mounted stop lamps while wide vehicles are not. Similarly, wide vehicles must have clearance and identification lamps which are not required on narrow vehicles. This same distinction occurs between narrow and wide trailers, for which common content significantly surpasses differentiated content. Therefore, we have concluded that it is unnecessary to section Table I by vehicle width.

We are retaining the title of the three sections of Table I as *Required Lamps and Reflective Devices*, even though one of the lamps listed in Table I-a, Daytime Running Lamp (DRL), is not a required lamp. The heading above the DRL listing clearly describes it as being permitted but not required. However, because the DRL, when installed, is regulated in all attributes listed in Table I, *Number and Color, Mounting Location, Mounting Height, and Device Activation* (unlike other non-required lamps), the agency decided that Table I is the appropriate location for it.

The three sections of Table IV, *Effective Projected Luminous Lens Area Requirements*, are now identified as: (1) Table IV-a covering turn signal and stop lamps; (2) Table IV-b for high-mounted stop lamps; and (3) Table IV-c for school bus signal lamps. The four sections of Table V, *Visibility*

Requirements of Installed Lighting Devices, now include: (1) Table V-a for backup lamps, high-mounted stop lamps, and school bus signal lamps; (2) Table V-b which contains the lens area option for turn signal lamps, stop lamps, taillamps, and parking lamps; (3) Table V-c which has the luminous intensity option for turn signal lamps, stop lamps, taillamps, and parking lamps; and (4) Table V-d that has older alternative requirements for turn signal lamps, stop lamps, and taillamps.

Table VI, *Front Turn Signal Lamp Photometry Requirements*, was split into two sections in the final rule. Table VI-a contains the base front turn signal lamp photometry requirements and also the values for 2½ times the base photometry requirements while Table IV-b contains values for 2 times the base photometry requirements and 1 the base photometry requirements

New Table XIII consisting of: (1) Table XIII-a, *Motorcycle Turn Signal Lamp Alternative Photometry Requirements*, and (2) Table XIII-b, *Motor Driven Cycle Alternative Photometry Requirements*, includes the stop lamp requirements for certain motor driven cycles previously part of Table IX in the NPRM, as well as alternative turn signal requirements for motorcycles noted in paragraph S7.1.1.1 and S7.1.2.1 of the NPRM but not previously tabularized. The three sections of Table XVI are now: (1) Table XVI-a, *Reflex Reflector Photometry Requirements*, (2) Table XVI-b, *Additional Photometry Requirements for Conspicuity Reflex Reflectors*, and (3) Table XVI-c, *Retroreflective Sheeting Photometry Requirements*.

Table XIX has been split into Tables XIX-a, containing photometric requirements for lower beam patterns LB1M, LB1V, LB2M, and LB2V. Table XIX-b contains requirements for lower beam patterns LB3M, LB3V, LB4M, and LB5M while Table XIX-c contains requirements for lower beam pattern LB4V.

As mentioned previously, the ASSN/AAM response proposed a common, templated organizational format for the individual lamp sections and expansion of their content to include 14 subsections representing specific requirements. The requirements that they suggested be included in each section include: (1) Number, (2) color of light, (3) arrangement, (4) position, (5) geometric visibility, (6) orientation, (7) effective projected luminous lens area, (8) electrical, (9) tell tale, (10) marking requirements, (11) other provisions, (12) plastic materials, (13) photometry, and (14) physical tests. Implementing this request presents a dilemma for several reasons. First, most of the requirements

suggested to be listed in individual lamp sections are already stated in parts of Table I, Table IV, and Table V. Table I of the NPRM is an expansion of Tables I, II, III, and IV of the current version of Standard No. 108, tables which have been part of the standard for decades. The agency rarely receives questions or complaints about regulatory content contained in Tables I through IV, but instead, they are often considered the most useful feature of the current version. We received no comments, including the ASSN/AAM submission, which suggested elimination of Table I.

We also believe that the suggestion of ASSN/AAM to remove the activation requirements from Table I and place them all in a new section titled "Electrical" was without merit. The activation requirements of the various types of lamps, like the other categories listed in Table I, are primarily vehicle-level requirements rather than device-level requirements, and are best presented along with those other requirements.

Table V of the NPRM is a restatement of Figures 19 and 20 of the current version of Standard No. 108, which were added in a final rule⁷ published on August 11, 2004 which promulgated the current visibility requirements. The agency decided that it would not be appropriate to disperse the visibility requirements of Table V (and likewise the effective projected luminous lens area requirements of Table IV) into individual lamp sections. The primary reason was that in real world situations, many lamp functions are combined with other lamp functions, very often optically combined. It is not unusual for a vehicle to have a combination rear lamp where the taillamp, stop lamp, and rear turn signal lamp functions are optically combined. The same holds true for front turn signal lamps and parking lamps. The presentation of visibility requirements for all regulated lamp functions together in Table IV allows regulated parties to quickly determine the appropriate requirements for such combination lamps and perhaps aid the decision about which visibility alternative to use for certification.

The decision to leave Tables I, IV, and V intact in the final rule means that adopting the ASSN/AAM template for individual lamp sections would result in large scale duplication of requirements in Standard No. 108. Duplication of the same requirement in more than one location in a regulatory document has the potential for

⁷ 69 FR 48805 (Aug. 11, 2004) (Docket No. 2004-18794-1).

unintended consequences. We intended to avoid those consequences by having each discrete requirement only stated once in Standard No. 108.⁸

Therefore, to be responsive to the request of ASSN/AAM concerning the format of individual lamp sections while still maintaining the integrity of the standard by having only a single statement of each requirement, we have adopted the use of pointing statements. These pointing statements appear in those subsections of each lamp section where a requirement does exist but is stated in another location of the standard. For instance, in paragraph S7.4 pertaining to side marker lamps, subsections 7.4.1 *Number*, 7.4.2 *Color of light*, 7.4.3 *Mounting location*, 7.4.4 *Mounting height*, and 7.4.5 *Activation*, all conclude with the pointing statement "See Tables I-a, I-b, and I-c." Similarly, S7.4.9 *Markings* points to S6.5 for details of the applicable marking requirements. S7.4.6 *Effective projected luminous lens area*, S7.4.7 *Visibility*, S7.4.8 *Indicator*, S7.4.10 *Spacing to other lamps*, S7.4.11 *Multiple compartment and multiple lamps*, and S7.4.12 *Ratio* all conclude with the term "No requirement" indicating a requirement for those specific items of lamp performance does not exist in Standard No. 108.

The entire content of Table III of the NPRM, dealing with conspicuity systems, was moved to paragraph S8.2 of the final rule. A new Table III was created to serve as a compilation of pointing statements directed to the locations within the final rule where marking requirements reside. While some headlamp marking requirements were relocated to paragraph S6.5 in the final rule, a number of other marking requirements continue to be dispersed within the document. In these cases, we have decided that the marking requirements are best located near the specific items to which they apply. However, these locations are all identified in Table III and consultation with this table should lead the user to all applicable marking requirements.

Grote suggested that lengthy paragraphs of regulatory text be simplified by splitting them into separately numbered sub-paragraphs, particularly where the requirements were diverse. In a number of instances, we have been able to create such separation. Regulatory provisions (including renumbered paragraphs) where this has been done include: S6.1.3, S6.1.4.2, S6.1.5.2, S6.2.6,

S6.5.3.3, S6.5.3.4, S6.6, S7.1.1.11, S7.1.1.12, S7.1.2.11, S7.1.2.12, S7.1.3, S7.2.11, S7.3.11, S7.3.12, S7.3.15, S7.7.13, S7.7.15, S7.9.14, S8.2.1, S8.2.2.3, S9.3.4, S9.8, S10.14.2, S10.17.1.1, S10.17.1.2, S10.17.1.3, S13, S14.1.4, S14.2.1, S14.2.3, S14.2.4, S14.2.5, S14.4.1, S14.4.2, S14.5, S14.6, S14.7, and S14.9. We have included the term "split for clarity" or similar language, often parenthetically, numerous places in the discussion of revisions to note where a section of text from the NPRM was divided into several smaller sub-sections in the final rule but not otherwise revised.

Guide submitted numerous suggestions for reorganizing the NPRM by the reassignment of certain paragraphs within the organizational framework of the NPRM. In several instances, the agency concluded that the Guide suggestion proved to be a more appropriate location for a paragraph than the location proposed in the NPRM. We have noted these reassignments in our discussion (but without attribution to a Guide suggestion in some cases). This has caused numerous changes in the paragraph numbers throughout the regulatory text. Where a requirement in the final rule was identified differently in the NPRM, we have indicated the previous paragraph number in the revision summary.

A number of Guide's suggested reassignments were not adopted, because we decided that the applicable textual provisions were already situated in the most appropriate location. Again, we did not mention every such rejection of Guide's suggested ordering or our reasoning for such decisions. While we believe that the final rule's organizational structure is the optimal choice, we recognize that it is not the only choice. Often, some of the requirements of Standard No. 108 intermix several attributes of lamps. Such an example is paragraph S7.11.2.1 which contains requirements for a DRL spaced near a turn signal lamp (*e.g.*, considerations for the actual separation distance, the luminous intensity of both the DRL and the turn signal lamp, whether the DRL is optically combined with a lower beam headlamp, and the activation properties of both the DRL and turn signal lamp). Requirements such as these do not fit neatly into a *Mounting Location* section or an *Activation* section, and their essence would not survive dispersion of the component requirements into these sections because of their interdependence on several diverse attributes.

Another such situation involves the presentation of the requirements for conspicuity systems. The content of Table III of the NPRM was moved to paragraph S8.2 of the regulatory text to provide a more comprehensible presentation format. An argument could be made that this content should be split into two portions, one portion describing how conspicuity material is spaced and arranged and another portion describing where conspicuity material is to be placed on applicable vehicles. If this apportionment were made, the first portion could be considered a device-level requirement and the second portion a vehicle-level requirement. Dispersing conspicuity system content in this way may seem correct from an organizational perspective, but would be in conflict with the goals of the rewrite of Standard No. 108 to present the requirements in a straight forward and logical manner.

Our guiding principle in organizing the structure of the FMVSS No. 108 final rule was to attempt to locate each requirement in the place where a user would be most likely to look for it. Accordingly, the final rule has been organized with the following major sections:

- S1 *Scope.*
- S2 *Purpose.*
- S3 *Application.*
- S4 *Definitions.*
- S5 *References to SAE publications.*
- S6 *Vehicle requirements.*
- S7 *Signal lamp requirements.*
- S8 *Reflective device requirements.*
- S9 *Associated equipment requirements.*
- S10 *Headlighting system requirements.*
- S11 *Replaceable light source requirements.*
- S12 *Headlamp concealment device requirements.*
- S13 *Replaceable headlamp lens requirements.*
- S14 *Physical and photometry test procedures and performance requirements.*

Tables

- Table I *Required Lamps and Reflective Devices.*
- Table II *Headlighting Systems.*
- Table III *Marking Requirements Location.*
- Table IV *Effective Projected Luminous Lens Area Requirements.*
- Table V *Visibility Requirements of Installed Lighting Devices.*
- Table VI *Front Turn Signal Lamps Photometry Requirements.*
- Table VII *Rear Turn Signal Lamps Photometry Requirements.*
- Table VIII *Taillamp Photometry Requirements.*
- Table IX *Stop Lamp Photometry Requirements.*
- Table X *Side Marker Lamp Photometry Requirements.*
- Table XI *Clearance and Identification Lamps Photometry Requirements.*

⁸ See the discussions of Table II and Table IX for explanations of existing duplicated requirements in the current version of FMVSS No. 108.

Table XII	<i>Backup Lamp Photometry Requirements.</i>
Table XIII-a	<i>Motorcycle Turn Signal Lamp Alternative Photometry Requirements.</i>
Table XIII-b	<i>Motor Driven Cycle Stop Lamp Alternative Photometry Requirements.</i>
Table XIV	<i>Parking Lamp Photometry Requirements.</i>
Table XV	<i>High-Mounted Stop Lamp Photometry Requirements.</i>
Table XVI	<i>Reflex Reflector and Retroreflective Sheeting Photometry Requirements.</i>
Table XVII	<i>School Bus Signal Lamp Photometry Requirements.</i>
Table XVIII	<i>Headlamp Upper Beam Photometry Requirements.</i>
Table XIX	<i>Headlamp Lower Beam Photometry Requirements.</i>
Table XX	<i>Motorcycle Headlamp Photometry Requirements.</i>

Figures

Figure 1	<i>Chromaticity Diagram.</i>
Figure 2	<i>Flasher Performance Chart.</i>
Figure 3	<i>Replaceable Bulb Headlamp Aim Pads.</i>
Figure 4	<i>Headlamp Connector Setup.</i>
Figure 5	<i>Headlamp Abrasion Test Fixture.</i>
Figure 6	<i>Thermal Cycle Test Profile.</i>
Figure 7	<i>Dirt/Ambient Test Setup.</i>
Figure 8	<i>Replaceable Light Source Deflection Test Setup.</i>
Figure 9	<i>Environmental Test Profile.</i>
Figure 10	<i>Headlamp Replaceable Light Source Pressure Test Setup.</i>
Figure 11	<i>Trailer Conspicuity Treatment Examples.</i>
Figure 12-1	<i>Trailer Conspicuity Detail I.</i>
Figure 12-2	<i>Trailer Conspicuity Detail II.</i>
Figure 13	<i>Tractor Conspicuity Examples.</i>
Figure 14	<i>92x150 Headlamp Aim Deflection Test Setup.</i>
Figure 15	<i>Types G and H Headlamp Aim Deflection Test Setup.</i>
Figure 16	<i>Types A and E Headlamp Aim Deflection Test Setup.</i>
Figure 17	<i>Type B Headlamp Aim Deflection Test Setup.</i>
Figure 18	<i>Types C and D Headlamp Aim Deflection Test Setup.</i>
Figure 19	<i>License Plate Lamp Target Locations.</i>
Figure 20	<i>License Plate Lamp Measurement of Incident Light Angle.</i>
Figure 21	<i>Vibration Test Machine.</i>
Figure 22	<i>Flasher Test Standard Circuit.</i>

4. Suggestions Beyond the Scope of the Rewrite

Units of Measurements

Several comments were received concerning the way quantities in the NPRM were measured, in terms of units. In some cases, measurements were only in metric units, others in only English units, and still others dual-dimensioned with both metric and English units. We note that this situation currently exists within Standard No. 108 and the SAE standards and Recommended Practices incorporated by reference. Such

perceived inconsistencies in the final rule are the result of the agency's decision to make no substantive changes to Standard No. 108 during the rewrite process. This means stating measurements in their original form consistent with their original source documents, instead of attempting to convert and standardize the units.

ASSN preferred dual English/metric measurements for every quantity and requested that both be provided in the final rule. The commenter also preferred that linear measurements be expressed in both inches and centimeters. AAM requested dual units with metric units followed by English units and the use of direct conversions to establish those measurements that were only stated in one unit in the NPRM. Nissan argued that in recent rulemakings, the agency has consistently listed measurements using metric units with English units referenced parenthetically. Nissan preferred linear measurements that were in millimeters, except for photometric test distances which should remain dimensioned in meters. Conversely, Grote recommended that measurements be expressed in inches followed by centimeters in parentheses, believing that the vast majority of current users continue to use English measurements. SEMA also supported dual units of measurements with a preference for centimeters rather than millimeters. In supplemental comments, AAM/ASSN requested all quantities in FMVSS No. 108 that are not now metric be converted to metric pursuant to Executive Order 12770 (*Metric Usage in Federal Government Programs*).

The FMVSS No. 108 rewrite is considered an administrative action because existing requirements and obligations are not being increased, decreased, or substantively modified. The agency has decided that converting values and providing dual-dimensions is outside the scope of this final rule. The conversion process, in some cases, would result in substantive change in the current requirements of the standard. This is because such conversions rarely result in a whole number equivalent, but more likely in an unwieldy value with more digits than the value it was converted from. The converted unit may have a non-exact value requiring it to be truncated after several digits. Such rounding may have little effect on some attributes but significant effect on others. An additional complication is that some currently dual-dimensioned values in FMVSS No. 108 are not exact equivalents. For instance, the air pressure required to be applied to the replaceable light source in the

replaceable light source pressure test is expressed as 70 KPa (10 psig). However, the English equivalent of 70 KPa is 10.152641661 psig and the metric equivalent of 10 psig is 68.9475728 KPa. Thus, a user may conclude that a replaceable light source may be compliant with the standard if it withstands a pressure of 68.9475728 KPa and not 70 KPa.

Additionally, the comments received in response to the NPRM show that users of FMVSS No. 108 do not have a consistent preference for a particular approach regarding units of measurement. In consideration of our principle not to change any existing requirements, as well as the wide range of opinions on the best approach for dual-dimensioning, the agency decided to present values consistent with the current standard instead of choosing one of the suggested options.

Photometric Maps

As previously mentioned, the AAM/ASSN supplementary comments, the ASSN initial comments, and the NAL comments recommend inclusion of a number of new graphical maps that would show details of the requirements for the various photometric test patterns. The signal lamp maps would show the position of each individual test point and how those points are combined into groups. The headlamp maps would show individual test points, linear test elements, and zonal test elements.

In reviewing the suggested graphical maps, it was unclear which test points were part of which zone. Furthermore, such maps are beyond the scope of the administrative rewrite. In addition, there were no compelling arguments presented addressing how their inclusion would advance the goals of the rewrite. Adding such graphical maps would provide redundant information, significantly increasing the risk of potentially conflicting requirements, and likely generate numerous interpretation requests, especially if users were confused by the new graphs.

That is not to say that these types of illustrations have no value. They seem particularly well suited for use by design and manufacturing organizations use in their internal design standards or photometric test procedures documents. Standard No. 108, like all Federal Motor Vehicle Safety Standards, strives to present regulatory requirements in the clearest way possible. It is not intended to serve as an all-inclusive working guide for designing, testing, or manufacturing lamps, reflective devices, or associated equipment. NHTSA

anticipates that user organizations will carefully incorporate the requirements of FMVSS No. 108 into their internal working documents.

Requests for New or Revised Definitions

Commenters requested inclusion in the final rule of numerous definitions for specific terms. These include: "center (of item)," "fixed body panel," "four lamp type headlamp," "hazard warning lamps," "obstruction," "rigid part of vehicle," "separately lighted areas," "two lamp type headlamp," "special tools," "tools ordinarily available," "supplemental lamp," and "auxiliary lamp." There was also a suggestion for a revised definition for the term "color bleeding," alleging it could be mistaken for the term "light bleed." A suggestion was also submitted for addition of definitions of all lamp types mentioned in the current version of FMVSS No. 108, with the specific example of fog lamp.

In its initial submission, AAM suggested the final rule use the term "* * * light source optical centers * * *" in place of the term "* * * light sources * * *" and the term "* * * optical centers * * *" in place of the term "* * * optical axes * * *" as revisions that would be technology-neutral in the specific case of a series wired array of LEDs being considered a single light source per the January 5, 2006 letter of interpretation to AMECA.⁹ There were also suggestions that the term "lighted section" be used exclusively and in place of "multiple compartment" and "multiple lighted area." Adopting any of these suggestions would have been a substantive action which would be beyond the defined scope of this rewrite. For this reason we have not adopted any of these suggested modifications in the final rule.

5. Suggestions Within the Scope of the Rewrite

SAE Documents

A significant initiative of the FMVSS No. 108 rewrite was the incorporation of requirements contained in SAE Standards and Recommended Practices (currently incorporated by reference or sub-reference) directly into the body of the standard. The current version of Standard No. 108 relies heavily on the content of numerous SAE documents. It contains over 100 references to some 35 different SAE documents, many of which were issued in the 1960s. Some of these documents are incorporated in their entirety, whereas only portions of others are cited. The NPRM integrated much of the content of these SAE

document directly into the regulatory language, resulting in only eight SAE documents continuing to be incorporated by reference.

Generally commenters supported this action. SEMA requested that all referenced and sub-referenced SAE documents be included in the regulatory text of the final rule. While total elimination of documents incorporated by reference proved to be impractical, we did eliminate references to three additional SAE documents in the final rule as discussed below. We also restored a reference to SAE J567b, *Bulb Sockets*, in S14.2.1.6.2 of the final rule based upon comments by Calcoast. This reference exists in Footnotes 2 and 3, which follow Table IV, of the current version of FMVSS No. 108, but was eliminated in the NPRM. We agree with Calcoast that the exemption permitted in these footnotes stating that bulbs not listed in SAE J573d, *Lamp Bulbs and Sealed Units*, December 1968, are not required to use a socket that conforms to the requirements of SAE J567b, *Bulb Sockets*, April 1964, is needed in the final rule.

SAE J577, *Vibration Test Machine*, April 1964, has been replicated as Figure 21, and all references to SAE J577 have been removed from the final rule. SAE J823b, *Flasher Test Equipment*, April 1968, describes a standard test circuit to be used in the performance testing of vehicular hazard warning signal flashers and turn signal flashers. This SAE standard also has specifications for power supplies used in these tests and describes the circuit adjustments necessary to perform valid tests. We have chosen to incorporate the content of SAE J823b into the final rule. New Figure 22, *Flasher Standard Test Circuit*, provides the test circuit schematic diagram from Figure 1 of SAE J823b. Paragraph S14.9.3.1 of the final rule states requirements for circuit adjustments applicable to flasher tests, and paragraph S14.9.3.2 provides separate power supply specifications for the various flasher performance tests. With the inclusion of paragraph S14.9.3 and Figure 22 in the final rule, all references to SAE J823b have been deleted.

SAE J588e, *Turn Signal Lamps*, September 1970, incorporated by reference in FMVSS No. 108, is referenced in paragraph S5.1.1.1 of the current version of the standard solely to establish requirements for double-sided turn signal lamps installed on truck tractors. It was eliminated from the final rule by incorporating the content of paragraph 3.4 and a portion of paragraph 3.9.1 of SAE J588e into paragraph S6.1.1.3 of the NPRM. The

remaining portion of paragraph 3.9.1 was incorporated in Table VII, *Rear Turn Signal Lamp Photometry Requirements*, of the NPRM by revision to Footnote 6.

The revised paragraph S6.1.1.3 now reads, "* * * A truck tractor need not be equipped with turn signal lamps mounted on the rear if the turn signal lamps at or near the front are of double-face construction and are located such that they meet the photometric requirements for double-faced turn signal lamps specified in Footnote 6 of Table VII." Continuing, paragraph S6.1.1.3.1 states, "The flashing signal from a double-faced signal lamp must not be obliterated when subjected to external light rays from either in front or behind, at any and all angles." The revised Footnote 6 to Table VII now states, "A double-faced turn signal lamp installed as described in paragraph S6.1.1.3 on a truck tractor need only meet the photometric requirements for a left side lamp where the lamp is mounted on the left side of the vehicle, and for a right side lamp where the lamp is mounted on the right side of the vehicle."

This same SAE standard, J588e, *Turn Signal Lamps*, September 1970, is cited in the current version of FMVSS No. 108 as containing the requirements for the illuminated pilot indicator for turn signal lamp failure. The NPRM had erroneously stated the requirements from SAE J588 NOV84, *Turn Signal Lamps*. Paragraph S9.3 of the final rule now correctly states the illuminated area of the indicator and the acceptable modes of indication. Consistent with these changes, all references to SAE J588e have been removed from the standard.

We undertook the effort to eliminate these additional SAE references in the final rule in part because the nature of some comments suggested that the relationship between FMVSS No. 108 and its incorporated SAE documents causes significant confusion.

One example of such confusion is found in the comments of Grote and Koito in reference to the limitations in applying reduced photometric requirements to adjacent front and rear side marker lamps. This section is based upon paragraph S5.1.1.8 of the current version of Standard No. 108 which states, "For each motor vehicle less than 30 feet in overall length, the photometric minimum candlepower¹⁰ requirements for side marker lamps specified in SAE Standard J592e,

¹⁰The term "candlepower" used in this context means the contemporary unit of measurement used to express the luminous intensity attribute.

⁹<http://isearch.nhtsa.gov/files/Wolford.2.html>.

Clearance, Side Marker, and Identification Lamps, July 1972, may be met for all inboard test points at a distance of 15 feet from the vehicle and on a vertical plane that is perpendicular to the longitudinal axis of the vehicle and located midway between the front and rear side marker lamps." In this case, the limitation of vehicles less than 30 feet in overall length recognizes that those vehicles are ones where intermediate side marker lamps (and intermediate side reflex reflectors) are not required to be installed. Table 1 of SAE J592e, detailing the photometric requirements of side marker lamps, also contains a footnote "b" further limiting the vehicles where reduced photometric requirements can be applied. Footnote "b" states that, "The requirements for side markers used on vehicles less than 80 inches (2 meters) wide may be met for inboard test points * * *" This vehicle width limitation is reflected in Footnote 1 of Table X. This is an example where the text of an incorporated SAE document applies limitations beyond those contained in the text of FMVSS No. 108.

Another example is illustrated in the comments by AAM and Koito about the spatial relationship between front turn signal lamps and certain other front-mounted lamps and the photometric requirements the relationship imposes on the front turn signal lamp as stated in paragraph S7.1.1.2 of the NPRM (S7.1.1.10 of the final rule). Current FMVSS No. 108, at paragraph S5.3.1.7, imposes a multiplier of 2.5 on minimum photometric intensity requirements for a front turn signal lamp mounted less than 100 mm from the lighted edge of a lower beam headlamp. Turn signal lamps are also required to be designed to conform to referenced standards SAE J588 NOV84 for vehicles less than 2032 mm in overall width and SAE J1395 APR85 for vehicles 2032 mm or more in overall width. These documents provide, in paragraph 5.1.5.4 of SAE J588 and paragraphs 5.1.5.4, 5.1.5.5, and 5.1.5.6 of SAE J1395, additional photometric requirements for turn signal lamps based upon their construction. The method the turn signal lamp uses to project light (i.e., whether it primarily uses a reflector to direct light or not) determines how the relationship is measured between the turn signal lamp and the lower beam headlamp, or a surrogate lower beam headlamp such as an auxiliary lower beam headlamp or a fog lamp. Based upon this measurement, the turn signal lamp may be required to have a multiplier of 1.5, 2.0, or 2.5 times the minimum photometric intensity. Thus,

it is possible for a turn signal lamp not to be required to have increased intensity based upon paragraph S5.3.1.7 of current FMVSS No. 108 but still be required to have increased intensity because of its construction or proximity to another front lamp, such as a fog lamp. This is an example where an incorporated SAE document imposes requirements beyond those explicitly stated in the regulatory text of Standard No. 108.¹¹

In its comments, AAM stated that FMVSS No. 108 has never contained a requirement for a vehicular hazard warning signal pilot indicator as contained in paragraph S6.6 of the NPRM (paragraph S9.8 of the final rule). We note that this requirement came from SAE J910, *Vehicular Hazard Warning Signal Operating Unit*, January 1966, and SAE J945, *Vehicular Hazard Warning Flasher*, February 1966, both incorporated by reference in Tables I and III of the current version of FMVSS No. 108. The requirements from SAE J910 contained in paragraph 5 detail how the pilot indicator is to operate, how it can be combined with the turn signal indicator, and the size and color of a dedicated vehicular hazard warning signal pilot indicator. The requirements from SAE J945 describe how the means of providing the indication can be incorporated into the flasher if it functions under all test conditions applied to the flasher and how an audible indication can be used in conjunction with the visible indication. This is an example where incorporated SAE documents contain a requirement that is not expressly stated in the text of FMVSS No. 108.

AAM also stated in its comments that only the lighting equipment requirements of SAE J587 OCT81, *License Plate Lamps (Rear Registration Plate Lamps)*, are incorporated by reference in Standard No. 108 (i.e., in paragraph S5.1.1 of the current version). AAM argued that a license plate holder is not an item of lighting equipment and that requirements for the holder would also apply to a front license plate holder. In response, we note that SAE J587 OCT81 does contain specific requirements for a license plate holder and its relationship with the license plate, the surface the vehicle stands on, and the license plate lamp. The performance of a license plate lamp is dependent upon its physical relationship with the license plate. The license plate must be secured in

position to evaluate this performance. To alleviate AAM's concern with application of the requirement to a front license plate holder, we have revised the text of paragraph S6.6.3 of the final rule (paragraph S6.1.1 of the NPRM) to state, "Each rear license plate holder must be designed and constructed to provide a substantial plane surface on which to mount the plate. The plane of the license plate mounting surface and the plane on which the vehicle stands must be perpendicular within $\pm 15^\circ$ " (emphasis added).

Grote commented that lamps designed to conform to SAE J1395 APR85, *Turn Signal Lamps for use on Motor Vehicles 2032 mm or more in Overall Width*, and SAE J1398 MAY85, *Stop Lamps for use on Motor Vehicles 2032 mm or more in Overall Width*, incorporated by reference in Table I of the current version of FMVSS No. 108 for use on multipurpose passenger vehicles, trucks, trailers, and buses, of 80 or more inches in overall width, could also be used on vehicles less than 80 inches (2032 mm) overall width, without meeting the requirements listed in Table III for these lamps. Grote based its comment on a statement in the *Scope* of SAE J1395 stating that, "Turn signal lamps conforming to this report may also be used on vehicles less than 2032 mm in overall width." The *Scope* of SAE J1398 has a similar statement concerning stop lamps. This assertion is simply not correct. Table III of the existing version of Standard No. 108 applies to all passenger cars and motorcycles, and multipurpose passenger vehicles, trucks, buses and trailers of less than 80 inches (2032 mm) in overall width. Table III clearly requires turn signal lamps to comply with SAE J588 NOV84 and stop lamps to comply with SAE J586 FEB84. Therefore, manufacturers may choose to design their lamps to also comply, respectively, with SAE J1395 APR85 and SAE J1398 MAY85, but they also must be designed to comply, respectively, with SAE J588 NOV84 and SAE J586 FEB84. We do not agree with the argument that compliance with only SAE J1395 APR85 and SAE J1398 MAY85, respectively, is permitted, because this clearly contradicts the language in the existing regulatory text.

Table III of the current version of FMVSS No. 108 requires that all passenger cars and motorcycles, and multipurpose passenger vehicles, trucks, trailers, and buses, of less than 80 inches (2032 mm) in overall width must be equipped with lamps designed to conform to the requirements of SAE J588 NOV84, *Turn Signal Lamps for use on Motor Vehicles Less Than 2032 mm*

¹¹ The subject of turn signal lamp photometric requirements based upon spacing to other front lamps is discussed in several interpretations such as Matsui (9/20/95).

in Overall Width, and SAE J586 FEB84, *Stop Lamps for use on Motor Vehicles Less Than 2032 mm in Overall Width*. Thus, if a turn signal lamp or stop lamp is not designed to conform with SAE J588 NOV84 or SAE J586 FEB84 respectively, it cannot be used on any passenger car or motorcycle or on any multipurpose passenger vehicle, truck, trailer, or bus of less than 80 inches in overall width, no matter whether it also is designed to conform to SAE J1395 APR85 or SAE J1398 MAY85. The explicit requirements of FMVSS No. 108 prevail over any seemingly contradictory language of an incorporated third-party document.

Observing the confusion that exists because the current version of Standard No. 108 relies so heavily upon reference to third-party documents, we are convinced that our action to remove those references to the maximum extent possible was a correct decision. Remaining references to SAE documents in the final rule include:

- S6.4.5 SAE J602, *Headlamp Aiming Device for Mechanically Aimable Sealed Beam Headlamp Units*, August 1963
- S9.3.5 SAE J941b, *Motor Vehicle Driver's Eye Range*, February 1969
- S10.14.7.7 SAE J602 OCT80, *Headlamp Aiming Device for Mechanically Aimable Sealed Beam Headlamp Units*
- S10.15.7.6 SAE J602 OCT80, *Headlamp Aiming Device for Mechanically Aimable Sealed Beam Headlamp Units*
- S10.16.3.6 SAE J602 OCT80, *Headlamp Aiming Device for Mechanically Aimable Sealed Beam Headlamp Units*
- S10.18.7 SAE J602 OCT80, *Headlamp Aiming Device for Mechanically Aimable Sealed Beam Headlamp Units*
- S10.18.7.2 SAE J602 OCT80, *Headlamp Aiming Device for Mechanically Aimable Sealed Beam Headlamp Units*
- S11.3 SAE J2009 FEB93, *Discharge Forward Lighting Systems*
- S14.2.1.6 SAE J573d, *Lamp Bulbs and Sealed Units*, December 1968
- S14.2.1.6.1 SAE J573d, *Lamp Bulbs and Sealed Units*, December 1968
- S14.2.1.6.2 SAE J573d, *Lamp Bulbs and Sealed Units*, December 1968
- S14.2.1.6.2 SAE J567b, *Bulb Sockets*, April 1964
- S14.7.3.1.2 SAE J2009 FEB93, *Discharge Forward Lighting Systems*

Cited Interpretations

In the rewrite proposal, the agency integrated the clarifications provided by key letters of interpretation into the regulatory text of the standard. The criteria used in determining whether an interpretation was significant focused on whether it provided value in clarifying the provisions in the standard. In the vast majority of cases, past requests for interpretation have identified questions regarding applicability of certain provisions of the

standard to specific design configurations. However, influential interpretations that clarified provisions of the standard, and continue to provide guidance to various parties beyond the original requestor, were believed to be particularly useful additions to the regulatory text. In the NPRM, the agency solicited public comment about additional interpretations that might be included in the final rule.

In their submissions, several commenters mentioned specific interpretations of FMVSS No. 108 as candidates for incorporation in the regulatory text of the final rule. In two instances, we decided that the cited interpretations would make the standard more precise and added them to the final rule. The two interpretations are discussed below. Several commenters suggested other potential interpretations for inclusion into the final rule; however the agency decided that none of these provided enough value in clarifying the provisions of FMVSS No. 108.

Nissan suggested that inclusion of the June 18, 1985 interpretation to Mr. Nakaya¹² would more precisely define where the measurement of the height of a high-mounted stop lamp should be made with respect to the rear window of a passenger car. A more detailed description of this interpretation is found in the discussion of revised paragraph S6.1.3.2.1 of the final rule.

A suggestion of TTMA was to incorporate an interpretative rule¹³ published in 1999 into the standard. This interpretative rule quantifies the "as near the top as practicable" mounting requirement that applies to clearance lamps and identification lamps mounted on a vehicle with cargo doors. That rule states that NHTSA will presume it practical to mount these lamps above the cargo doors when the header above those doors extends at least 25 mm (1 inch) above them. A more detailed discussion of this issue is found in the discussion of Table I.

Revisions to the Proposal

S1 Through S3

There were no comments submitted that related to S1, S2, or S3.

S4 Definitions

AAM objected to mounting and spacing criteria being part of the definitions of a clearance lamp, identification lamp, and side marker lamp. In response, we note that all three of these definitions are faithful to the

applicable, long-referenced, SAE standards whose content we have included in both the proposal and final rule text. These mounting and spacing criteria serve to clarify the spatial function of the lamps and are appropriate parts of the definitions. Therefore, we are keeping these criteria in the final rule.

We removed the third sentence from the definition of "*effective projected luminous lens area*," stating the term "*functional lighted lens area*" appearing in any SAE document had an identical meaning. The single instance of the term "*functional lighted (lens) area*" appearing in the NPRM was in paragraph S7.1.1.2.2 (S7.1.1.10.3 in the final rule) in reference to the procedure to determine the measurement point for a front turn signal lamp with a reflector. We replaced "*functional lighted (lens) area*" in paragraph S7.1.1.10.3 with "*effective projected luminous lens area*" and were thereby able to remove any reference to "*functional lighted lens area*" in the standard.

Nissan observed that the definitions for "mechanically aimable headlamp" and "material" were not in alphabetical order in the NPRM. We have corrected this in the final rule.

GE commented that the definition of "replaceable light source" in the NPRM was not identical to that of the current version of FMVSS No. 108. As stated in the NPRM "replaceable light source," means an assembly of a capsule, base, and terminals *manufactured as a light source for an upper and/or lower beam of a replaceable bulb headlamp* that is designed to conform to the requirements of Appendix A or Appendix B of 49 CFR part 564, *Replaceable Light Source Information*. The italicized text was added to the definition included in the current version of FMVSS No. 108 as part of an attempt to clarify that integral beam and replaceable bulb headlamps are allowed to incorporate "replaceable light sources" that are used for purposes other than headlighting. However these "replaceable light sources" are not those defined in S4, but rather ones typically used for non-headlighting functions such as turn signal lamps, parking lamps, and front side marker lamps. In the final rule, as explained later in the discussion of S10 *Headlighting system requirements*, we have decided to address this issue by revising how these non-headlighting light sources were described. Because the revisions in language in S10 should eliminate confusion between headlighting and non-headlighting replaceable light sources, there is no need to change the definition in S4 and it is identical in the

¹² <http://isearch.nhtsa.gov/gm/85/1985-02.42.html>

¹³ 64 FR 16358, (April 5, 1999).

final rule to that of the current version of FMVSS No. 108.

Nissan commented that the definitions for “vehicular hazard warning signal flasher” from SAE J945, *Vehicular Hazard Warning Signal Flasher*, February 1966, and for “vehicular hazard warning signal operating unit” from SAE J910, *Vehicular Hazard Warning Signal Operating Unit*, January 1966, described the function of the hazard warning signal system in slightly different ways. Nissan contended, and we agree, that the description of the operation of the hazard warning signal system should be consistent. Therefore, we have revised the definition of “vehicular hazard warning signal flasher” from “ * * * means a device which, as long as it is turned on, causes all the required hazard warning lamps to flash” to “ * * * means a device which, as long as it is turned on, causes all the required turn signal lamps to flash.” Similarly the definition of the “vehicular hazard warning signal operating unit” was revised from “ * * * means a driver controlled device which causes all turn signal lamps, or other hazard warning lamps, to flash simultaneously to indicate to approaching drivers the presence of a vehicular hazard” to “ * * * means a driver controlled device which causes all required turn signal lamps to flash simultaneously to indicate to approaching drivers the presence of a vehicular hazard”. This revision recognizes that the hazard warning signal of paragraph S6.1.5.1 only requires simultaneous flashing of sufficient turn signal lamps to meet the turn signal photometric requirements of Standard No. 108.

S5 References to SAE Publications

In paragraph S5.2 of the NPRM we stated that “A complete list of all SAE publications incorporated by reference in this standard are indexed at 49 CFR 571.5(j)”. This inclusion was in anticipation of a final rule based upon a NPRM¹⁴ that would have established 49 CFR 571(j) to contain this list. This final rule has not been issued. Therefore, we have deleted this reference from the final rule.

AAM requested that the word “required” be inserted into the first sentence of paragraph S5.1 between the words “Each” and “lamp” to be faithful to paragraph S5.1.1 of the current version of FMVSS No. 108 containing provisions for lamps, reflective devices, and associated equipment to be designed to comply with specific SAE

Standards and Recommended Practices. We agree and have revised the final rule.

S6 Vehicle Requirements

Proposed paragraph S6.1.1.1, allowing conspicuity material on a trailer to also serve as the required reflex reflectors if the conspicuity material was placed at the required locations of the reflex reflectors, has been relocated into the Reflex Reflectors portion of Table I-b of the final rule.

Paragraph S6.1.1.3 was modified as stated in the *SAE Documents* section above to fully integrate the requirements of SAE J588e, *Turn Signal Lamps*, September 1970, relating to the use of double-faced turn signal lamps on truck tractors. This amendment also required a revision to Table XII and its Footnote 6 as well as the addition of paragraph 3.9.1 of SAE J588e as paragraph S6.1.1.3 of FMVSS No. 108 and paragraph 3.4 of SAE J588e as paragraph S6.1.1.3.1 of FMVSS No. 108.

Paragraph S6.1.1.4 of the final rule, (paragraph S6.2.4 of the NPRM), was moved into the *Vehicle requirements* section based upon the Guide comment that it was a more appropriate location than the *Impairment* section. A typographical correction was also made to clarify that a parking lamp or a fog lamp may not be used as a DRL. This correction now results in language that is faithful to the current version of FMVSS No. 108 at paragraph S5.5.11(a).

Paragraph S6.1.1.4, *Hazard warning lamps*, of the NPRM describing activation provisions for hazard warning lamps was moved to the Activation section where it became paragraph S6.1.5.1 in the final rule.

The phrase “fixed body panel” in proposed paragraph S6.1.3.1 was objected to by Koito as being more restrictive than the phrase “rigid part” which is used in the current version of FMVSS No. 108 at paragraph S5.3. We have decided to retain “rigid part” in the final rule to be faithful to the original language and meaning. The phrase “ * * * the mounting location and * * * ” has been added to paragraph S6.1.3.1 ahead of “height” to be consistent with the references to Tables I, II, III, and IV of the current version of FMVSS No. 108 as referenced at paragraph S5.3 of that document. This clarification was recommended by Guide.

Guide also suggested that the requirements of the second sentence of paragraph S6.1.3 of the NPRM, which becomes paragraph S6.1.3.2 of the final rule, deal more with photometry than lamp mounting location. We do not agree with this suggestion. This

requirement deals with how to consider, for photometry purposes, the individual compartments or lamps of an array that consists of portions on both rigid and non-rigid parts of the vehicle as described in the July 12, 2000, letter of interpretation to Mr. King.¹⁵ Because this provision establishes photometric performance requirements based upon what kind of surface a lamp is mounted upon, its inclusion in the *Mounting location* section is appropriate. We have added a pointing statement in paragraphs S7.1.1.11.1 (front turn signal lamps), S7.1.2.11.1 (rear turn signal lamps), S7.2.11.1 (taillamps), and S7.3.11.1 (stop lamps) in the final rule to direct users to this requirement. Guide also stated that this section should also apply to the rear reflex reflector. However, as stated in several interpretations, reflex reflector requirements must be met by single reflectors, not a combination of separate reflectors. Supporting this position is the May 23, 2003 letter of interpretation to Mr. Babcock¹⁶ as well as the April 14, 2004 letter of interpretation to Mr. Strassburger.¹⁷

Paragraph S6.1.4, *License plate lamp*, of the NPRM has been relocated to paragraph S6.1.3.3 of the final rule in recognition that it states a requirement for mounting location.

Paragraphs S7.9.1, *Accessibility*, and S7.9.2 *Interior mounting*, (duplication at S6.1.3.2.2 deleted) of the NPRM referring to high-mounted stop lamps (HMSL) were relocated in the final rule to be paragraphs S6.1.3.4.2 and S6.1.3.4.1 respectively. These requirements relate primarily to how the HMSL is mounted to the vehicle, so paragraph S6.1.3 is the most appropriate location in Standard No. 108 for them.

Guide commented that the content of paragraphs S8.1.3 and S8.1.4 of the NPRM, dealing with headlamp beam mounting, belonged in that part of Standard No. 108 related to lamp mounting location. We agree and have moved them intact to become paragraph S6.1.3.5 of the final rule.

Grote, Guide, Innovative, TMA, and TTMA all noted the typographical error in paragraph S6.2.5 of the NPRM. Both the title and text of this section contained the phrase “ * * * auxiliary identification lamp * * * ” which should be “ * * * auxiliary lamp * * * ”. The correction has been made in the final rule, and this requirement has been relocated to the *Mounting location*

¹⁵ <http://isearch.nhtsa.gov/files/21605.ztv.html>.

¹⁶ <http://isearch.nhtsa.gov/files/babcock.ztv.html>.

¹⁷ <http://isearch.nhtsa.gov/files/GF007569-2.html>.

section as paragraph S6.1.3.6, as it states a mounting limitation.

Paragraph S6.1.3.2.1 of the NPRM becomes paragraph S6.1.4.1, *High-mounted stop lamp*, in the final rule. Nissan suggested that the term "window" in the text had been defined more precisely in the June 18, 1985 letter of interpretation to Mr. Nakaya¹⁸ as "glazing" and suggested use of that term in the final rule. We agree and revised the text accordingly.

Guide commented that paragraph S6.1.5.1 of the NPRM, concerning optional activation of stop lamps by vehicle retarders, duplicated Table I. Upon review, we believe it is a duplication, and we have decided that Table I is the appropriate location for it. Therefore, in the final rule this allowance is included in the *Stop lamp-Device Activation* portion of Tables I-a, I-b, and I-c.

We have relocated to paragraph S6.1.5.1 of the final rule the content of paragraph S6.1.1.4 of the NPRM stating requirements of the hazard warning signal. This is appropriate since, as we noted in our discussion of the definitions of *vehicular hazard warning signal flasher* and *vehicular hazard warning signal operating unit*, the only requirement of this system is simultaneous flashing of sufficient turn signal lamps to meet the turn signal photometric requirements of Standard No. 108.

Another section relocated to S6.1.5, *Activation*, is paragraph S6.1.5.2 of the final rule, which details the requirements for simultaneous activation of lower beam and upper beam headlamps. These requirements had been included as paragraph S8.2 of the NPRM. We agree with the comment of Guide that this content was most appropriately located in the *Activation* section.

We removed paragraph S6.2.3 of the NPRM, which addressed specific requirements for auxiliary lamps performing the function of a required lamp, from the final rule. Grote, Guide, SEMA, and TMA persuaded us that the proposed S6.2.3 contained language that was not faithful to the current version of FMVSS No. 108 and did not add to the understanding of impairment.

Paragraph S14.2 of the NPRM was relocated to be paragraph S6.2.6 of the final rule. This section states the restrictions that apply to equipment in front of a headlamp lens. Paragraph S6.2, *Impairment*, was judged the most appropriate location for it. SEMA suggested revising the language of this

section in a way that was inconsistent with the current version of Standard No. 108 by allowing obstructions if some undefined visibility requirement were met. This suggestion would be a substantive change outside the scope of this rewrite project, and, as such, was not adopted in the final rule.

As previously mentioned, paragraph S6.2.4 of the NPRM stating the requirements for DRLs was relocated to be paragraph S6.1.1.4 of the final rule.

The text of paragraph S6.3, *Equipment combinations*, of the final rule remains identical to that of the NPRM.

Paragraph S6.4, titled *Visibility and aiming* in the NPRM, was re-titled *Lens area, visibility and aiming* in the final rule, recognizing the lens area requirements of paragraph S6.4.1. References in paragraph S6.4 to Table IV were revised in the final rule to reference Table IV-a, Table IV-b, or Table IV-c, as appropriate.

AAM and Koito commented that the requirement of a manufacturer to irrevocably certify compliance to one of the visibility options of paragraph S6.4.3 was on a "lamp function" basis rather than a "lamp" basis as stated in the NPRM. We agree and have revised the text of paragraph S6.4.3 accordingly to bring it in conformity to the final rule¹⁹ establishing these visibility requirements.

Nissan objected to the title of paragraph S6.4.4, *SAE visibility alternative*, of the NPRM stating they did not like the use of the term SAE as part of that title. Considering one of the goals of the FMVSS No. 108 rewrite was to reduce reliance upon third party documents, particularly SAE documents incorporated by reference, we have eliminated "SAE" from the paragraph S6.4.4 title in the final rule. The title of this section in the final rule is *Legacy visibility alternative* recognizing that it contains requirements that have long been a part of Standard No. 108.

Nissan also commented that paragraph S6.4.5, *Low-mounted lamps*, duplicated requirements stated in footnotes to Tables V-b, V-c, VI, VII, VIII, IX, XI, XIV, XVI-a, and XVII. We agree with Nissan that these footnotes are the appropriate location for these requirements and have eliminated this subparagraph from the final rule.

The addition of a new Table III to the final rule as a repository for listing the location in the regulatory text of each marking requirement of Standard No. 108 is noted in paragraph S6.5.

AAM and Koito noted that the regulatory requirement identified in paragraph S6.5.1 of the NPRM for the "DOT" marking was stated as "the standard" rather than "49 U.S.C. 30115" as stated in paragraph S7.2(a) of the current version of FMVSS No. 108. We have revised the text of this section in the final rule to be faithful to the existing language.

Paragraph S6.5.2, *DRL marking*, has been revised in the final rule to include the phrase "* * * on its lens * * *" after "DRL" to be faithful to the marking requirement as stated in paragraph S5.5.11(a)(2) of the current version of FMVSS No. 108.

Several sections of the NPRM containing marking requirements for headlamps have been relocated in their entirety and without revision to paragraph S6.5.3 of the final rule. These include: (1) Proposed paragraph S17.1 which becomes S6.5.3.1; (2) S17.2 which becomes S6.5.3.2; (3) S17.3 which becomes S6.5.3.3 (split into several sections for clarity); and (4) S17.4 which becomes S6.5.3.4 (split for clarity and updated section references). Similarly, proposed paragraph S17.5 summarizing the location of other headlamp marking requirements becomes paragraph S6.5.3.5.

Proposed paragraph S6.6 stating requirements for associated equipment on regulated vehicles has been updated to indicate that the specific requirements for associated equipment are located in paragraph S9 of the final rule.

Proposed paragraph S6.6.1, *License plate holder*, has been redesignated as paragraph S6.6.3 in the final rule due to renumbering of portions of paragraph S6.6 for clarity. AAM objected to this provision as stated previously in our discussion of SAE documents. The clarification that this section applied to *rear* license plate holders appears in the final rule (emphasis added).

Paragraph 6.7, *Replacement equipment*, of the NPRM continues as that paragraph in the final rule. AAM, ASSN, and SEMA noted a typographic error in paragraph S6.7.1.2 where the word "to" inadvertently appears in the phrase "* * * designed so that it does not to take the vehicle * * *" (emphasis added). This error was corrected by removing that word from paragraph S6.7.1.2 of the final rule. SEMA commented that the language of paragraph S6.7 "* * * infers that the standard would not preclude the installation of newer technologies on older vehicles and there is no suggestion that the introduction of lighting equipment into the marketplace is tied to vehicle manufacturer certification,"

¹⁸ <http://isearch.nhtsa.gov/gm/85/1985-02.42.html>

¹⁹ 69 FR 48805 (August 11, 2004) (Docket No. 2004-18794).

and requested confirmation of this assumption by a response to its letter of December 16, 2005 requesting an interpretation by the Chief Counsel. SEMA's comment sought clarification of a notice of interpretation published in the **Federal Register** on November 1, 2005²⁰ rather than addressing the substance of the rewrite of Standard No. 108, and, thus, was beyond the scope of the rewrite. We note that SEMA's concern was addressed by the agency in an August 24, 2006 letter of clarification.²¹

In its comments, ASSN objected to the inclusion of the second sentence of paragraph S6.7.1.2 of the NPRM which states in part, “* * * the determination of whether a vehicle would be taken out of compliance with this standard when an individual device is installed on the vehicle is made without regard to whether additional devices, including separate lamps or reflective devices sold together with the device, would also be installed.” Its contention is that this language which “converts its informal interpretation into a formal rule” was included in the rewrite of FMVSS No. 108 without “the required cost benefit analysis” and would limit the “opportunities for vehicle personalization.” The incorporation of the replacement equipment interpretation of 70 FR at 65972, or any interpretation, does not constitute a change in the requirements of the standard. An interpretation simply clarifies the existing requirements of the standard and as such does not require the cost-benefit analysis or other rulemaking formalities as ASSN suggested. Regulated parties are bound by the regulatory requirements regardless of whether they are expressed in the regulatory text or in interpretations either by letter or publication. A vehicle owner can continue to modify the lighting on his vehicle, including obtaining devices for that purpose from regulated parties such as vehicle dealers, so long as the vehicle continues to meet the requirements of FMVSS No. 108 and the replacement lighting equipment provides all regulated functions of the device being replaced in a single unit.

Grote also commented on paragraph S6.7, requesting that the provisions of paragraph S6.7.1.2 not be applicable to heavy vehicles. Grote was concerned that a replacement lamp, reflective device, or item of associated equipment which is designed or recommended for particular vehicle models must be

designed per S6.7.1.2 so that it does not take the vehicle out of compliance with this standard when the individual device is installed on the vehicle. Grote suggested that in the heavy vehicle market that it primarily serves, an owner of a fleet of heavy vehicles may elect to remove the original equipment lamps and reflective devices and replace them with equally compliant lamps and devices but in different functional combinations. That means, for example, one of a set of original equipment lamps installed on a particular vehicle may contain the stop lamp, taillamp, and side marker lamp function, while the other separate lamp contains the turn signal lamp, backup lamp, and reflex reflectors. Grote would like to be able to recommend a set of replacement lamps for this vehicle where the individual lamps of the set do not have the required functions grouped in exactly the same combinations as those of the original equipment set.

Grote believes that it should be permissible to do this because the agency stated in the interpretation²² published in the **Federal Register** on November 1, 2005 that, “* * * while our interpretation of S5.8.1 [of the current version of FMVSS No. 108] is not dependent on the size of the vehicle for which a lamp is intended, it has a more limited application to aftermarket lighting equipment for heavy vehicles than to light vehicles.” However, the agency continued the discussion by stating, “The specific context of the questions asked by Calcoast was aftermarket combination lamps for light vehicles, such as passenger cars. These lamps are typically designed for specific models and can only be installed on those models in the same location as the lamps they replace. However, for heavy vehicles, lighting equipment is often generic and not designed for specific models. Truck-Lite, for example, commented on our notice of draft interpretation that it sells many kinds of lighting devices through catalog sales to hundreds of vehicle manufacturers whose equipment it has no way of knowing about. Consistent with our discussion in the October 2004 notice of interpretation, we note that our interpretation does not mean that the manufacturer of generic lighting equipment has the responsibility for ensuring correct selection and installation of its equipment. On the other hand, under our interpretation, a manufacturer of aftermarket lighting equipment could not design or recommend lighting equipment for a specific vehicle if the vehicle

manufacturer could not have certified the vehicle using that lighting equipment instead of the lighting equipment it actually used.” We did not suggest in this interpretation that when we spoke of a “more limited application” in reference to heavy vehicles, we intended to treat replacement lamps and reflective devices for heavy vehicles significantly different than those for light vehicles. We were merely pointing out that we did not consider manufacturers of generic lighting equipment responsible for ensuring the correct selection and installation of their equipment. Therefore, with the exception of the previously mentioned typographical error correction, paragraph S6.7 in the final rule is identical to that of the NPRM.

Proposed paragraph S6.8 of the NPRM has been relocated to be part of paragraph S14 of the final rule. Substantive issues raised in the public comments to the NPRM will be discussed in paragraph S14.

S7 Signal Lamp Requirements

Paragraph S7 of the NPRM contained specific requirements for signal lamps, reflective devices, and associated equipment. With the reorganization of the final rule, only the signal lamp requirements remain in S7. In some cases, the order of appearance of specific lamp types in S7 has changed from the NPRM.

As previously mentioned, we have partially adopted the request of ASSN/AAM concerning the format of individual lamp sections. We have modified the individual signal lamp sections so that a series of specific types of requirements are listed for each lamp in the same order in a “template” format. These requirements, in order, are: (1) *Number*, (2) *Color of light*, (3) *Mounting location*, (4) *Mounting height*, (5) *Activation*, (6) *Markings*, (7) *Effective projected luminous lens area*, (8) *Visibility*, (9) *Indicator*, (10) *Spacing to other lamps*, (11) *Multiple compartment and multiple lamps*, and (12) *Ratio*. These are followed by sections on *Photometry* and *Physical tests*. In many cases, the text following one of these types of requirements will “point” to a table or another section of the standard. Also, there are numerous instances where the specific lamp has no performance requirement for a category, and the text states “No requirement.”

References to physical tests applicable to signal lamps contained in Table XXII of the NPRM have been revised in the final rule to refer to paragraphs S14.4 and S14.5.

²⁰ 70 FR 65972 (Nov. 1, 2005) (Docket No. NHTSA 03-15651).

²¹ <http://isearch.nhtsa.gov/files/SEMA.htm>

²² 70 FR 65972 (Nov. 1, 2005).

Paragraph S7.1 of the final rule continues to contain the requirements for turn signal lamps. Paragraph S7.1.1.3 of the NPRM, addressing multiple compartment and multiple front turn signal lamps, becomes paragraph S7.1.1.11 in the final rule and has been split for clarity. In this section, Nissan stated that the term "compartments" after the word "three" was incorrectly plural; it has been changed to singular form in the final rule.

As mentioned in the discussion of definitions, we replaced the term "functional lighted area" in paragraph S7.1.1.2.2 of the NPRM (paragraph S7.1.1.10.3 in the final rule), with the equivalent term "effective projected luminous lens area." Since this paragraph was the only instance in Standard No. 108 where the term "functional lighted area" was used, it was eliminated from the definition of "Effective projected luminous lens area" in the final rule.

Calcoast objected to the language of paragraph S7.1.1.3.1 of the NPRM which stated, "* * * overall width must meet the photometric requirements specified for a single section and not * * *" photometric requirements for lamps installed on vehicles 2032 mm or more in overall width. In the final rule, we have changed this language in paragraph S7.1.1.11.4 to be faithful to the language of paragraph S5.1.1.12 of the current version of FMVSS No. 108. It now states, "* * * overall width require measurement of the photometrics for the entire lamp and not * * *" This same issue was raised concerning rear turn signal lamps and stop lamps. Therefore, similar changes were made in paragraph S7.1.2.11.4 of the final rule for rear turn signal lamps and in paragraph S7.3.11.4 for stop lamps.

Paragraph S7.1.1.3.2 of the NPRM (containing requirements for the ratio between the photometric intensity of a front turn signal lamp and that of a parking lamp or clearance lamp where optically combined) has become paragraph S7.1.1.12 in the final rule and has been split for clarity.

Paragraph S7.1.2.2 of the NPRM (addressing multiple compartment and multiple rear turn signal lamps) becomes paragraph S7.1.2.11 in the final rule and has been split for clarity. Once again, Nissan stated that in this section, the term "compartments" after the word "three" was incorrectly plural; it has been changed to singular form in the final rule.

Paragraph S7.1.2.3 of the NPRM (containing requirements for the ratio between the photometric intensity of a rear turn signal lamp and that of a

taillamp or clearance lamp where optically combined) becomes paragraph S7.1.2.12 in the final rule and has been split for clarity.

Paragraph S7.2.1.1 of the NPRM (addressing multiple compartment and multiple taillamps) becomes paragraph S7.2.11 in the final rule and has been split for clarity. Again, Nissan stated that in this section the term "compartments" after the word "three" was incorrectly plural; it has been changed to singular form in the final rule. Also, AAM and Koito commented that there was an incorrect reference to Table VII instead of Table VIII in the NPRM; this has been corrected in the final rule.

Paragraph S7.2.12, *Ratio*, has been added in the final rule to point to the ratio requirements for rear turn signal lamps and stop lamps optically combined with taillamps.

Paragraph S7.3.1.1 of the NPRM (addressing multiple compartment and multiple stop lamps) becomes paragraph S7.3.11 in the final rule and has been split for clarity. Again, Nissan stated that in this section the term "compartments" after the word "three" was incorrectly plural; it has been changed to singular form in the final rule.

Paragraph S7.3.1.2 of the NPRM (containing requirements for the ratio between the photometric intensity of a stop lamp and that of a taillamp where optically combined) becomes paragraph S7.3.12 in the final rule and has been split for clarity.

Koito commented about the limitation of the application of reduced photometry requirements of paragraph S7.4.1.1 of the NPRM to side marker lamps installed on vehicles less than 80 inches wide. This limitation is consistent with Table 1, footnote "b" of SAE J592e. A more comprehensive discussion of this issue is part of the section on SAE documents in this final rule.

Paragraph S7.5.12, *Ratio*, has been added in the final rule to point to the ratio requirements for front and rear turn signal lamps optically combined with clearance lamps.

Paragraphs S7.7.2, *Photometry*, and S7.7.1, *Installation*, of the NPRM (applicable to license plate lamps) have been split for clarity as paragraphs S7.7.13 and S7.7.15 respectively, in the final rule.

A reference to new Figure 20, *License Plate Lamp Measurement of Incident Light Angle*, was added to paragraph S7.7.15.4 of the final rule (paragraph S7.7.1.1 in the NPRM.)

Paragraphs S7.9.1, *Accessibility*, and S7.9.2, *Installation*, of the NPRM

(applicable to high-mounted stop lamps) were relocated in the final rule to be paragraphs S6.1.3.4.2 and S6.1.3.4.1, respectively.

Guide commented that paragraph S7.11.2.2(c) of the NPRM should be relocated to the DRL activation portion of Table I-a. We disagree. This requirement, which becomes paragraph S7.10.10.1(c) in the final rule, only specifies activation and deactivation of the DRL when the turn signal is activated on a vehicle where the DRL is in close proximity to a turn signal lamp. Given these constraints of limited application, its present placement in the final rule is the most appropriate location. A statement in the DRL activation portion of Table I-a does point to paragraph S7.10.10.1(c) to also alert users to this requirement.

S8 Reflective Device Requirements

Requirements for reflex reflectors located in paragraph S7.10 of the NPRM have been relocated to paragraph S8.1 in the final rule. Paragraphs S8.1.1 through S8.1.10 are categorized identically to the organizational template of signal lamps. However, a section covering multiple compartment lamp and multiple lamps and a section covering ratio are clearly not applicable to reflex reflectors and are not included. Paragraph S8.1.11, *Photometry*, replaces paragraph S7.10.1 of the NPRM, while paragraph S8.1.12, *Physical tests*, replaces paragraph S7.10.2 and paragraph S8.1.13, *Alternative reflex material*, replaces paragraph S7.10.1.1.

References to physical tests applicable to reflex reflectors contained in Table XXII of the NPRM have been revised in the final rule to refer to paragraphs S14.4 and S14.5.

The final rule combines the content of paragraph S7.12 and Table III of the NPRM into paragraph S8.2. Specifically, proposed paragraph S7.12 becomes paragraph S8.2, proposed paragraph S7.12.1 becomes paragraph S8.2.1, *Retroreflective sheeting*, (split for clarity), and proposed paragraph S7.12.1.1 becomes paragraph S8.2.1.3, *Certification marking*.

Following this, the text of the proposed *Application pattern-Alternating red and white materials-Retroreflective sheeting* box of Table III is stated as paragraph S8.2.1.4, the text of the proposed *Application location-Retroreflective sheeting* box of Table III is stated as paragraph S8.2.1.5, and the text of the proposed *Application spacing-Retroreflective sheeting* box of Table III is stated as paragraph S8.2.1.6.

3M commented that they believe that the use of the phrase "* * * material is required to be installed * * *" in both

the requirements for *Application pattern-Retroreflective sheeting* and *Application pattern-Conspicuity reflex reflectors* implies that there is only one method of meeting conspicuity requirements, not two alternative methods. To increase clarity of these alternative requirements, we have revised the first sentence of the *Alternating red and white materials-Retroreflective sheeting*, (now paragraph S8.2.1.4.1) requirement to read “* * * where alternating material is installed * * *” We have also eliminated the phrase “Where alternating color material is required to be installed” from the beginning of the first sentence of *Alternating red and white materials-Conspicuity reflex reflectors* section (now paragraph S8.2.2.1).

3M also commented that the language in the *Application pattern-White material-Conspicuity reflex reflectors* section (paragraph S8.2.2.2 of the final rule) discussing the dimensional relationship between adjacent white conspicuity reflex reflectors would be more appropriately included in the *Application location* portion. We disagree because the requirements in the *Application location* portion refer to the location of the material on the vehicle while the requirements in the *Application pattern* portion only refer to the location of a reflector to an adjacent reflector.

AAM commented that the language of the *Application location-Retroreflective sheeting* portion begins with the phrase “Not permitted * * *” which imposes a different requirement than paragraph S5.7.1.4 of the current version of FMVSS No. 108 which states “* * * but need not be applied * * *” We agree and have revised the requirement of the *Application location-Retroreflective sheeting* (now paragraph S8.2.1.5 in the final rule) to begin, “Need not be installed, as illustrated in Figure 12-2, * * *”

Proposed paragraph S7.12.1.2, *Photometry*, becomes paragraph S8.2.1.7 in the final rule with no substantive changes. The photometry requirements reference was updated to Table XVI-c and the photometry test procedure reference to paragraph S14.2.3.

Proposed paragraph S7.12.2, *Conspicuity reflex reflectors*, becomes paragraph S8.2.2 and proposed paragraph S7.12.1, *Certification marking*, becomes paragraph S8.2.2.1 in the final rule.

Following this, the text of the proposed *Application pattern-Alternating red and white material-Conspicuity reflex reflectors* box of Table III is stated as paragraph S8.2.2.2.1 and the proposed *Application*

pattern-White material-Conspicuity reflex reflectors box of Table III is stated as paragraph S8.2.2.2.2. Regarding retroreflective sheeting, we have addressed the previously noted 3M comment about alternative methods of meeting conspicuity requirements by eliminating the phrase “Where white material is required to be installed” from the beginning of the first sentence of the *Application pattern-White material-Conspicuity reflex reflectors* (now paragraph S8.2.2.2) section.

Proposed paragraph S7.12.2.2, *Photometry*, has become paragraph S8.2.2.3 (split for clarity) in the final rule.

Paragraph S8.2.3 of the final rule contains the requirements for conspicuity systems installed on trailers that were part of Table III in the NPRM. Paragraph S8.2.3.1 (split for clarity) includes the requirements for the three conspicuity elements required on the rear of a trailer and paragraph S8.2.3.2 (split for clarity) states requirements for the alternating color side conspicuity treatment required on trailers.

AAM requested that the specific grades of sheeting permitted be mentioned in the requirements for *Trailer rear-Element 2-white*, now in paragraph S8.2.3.1.2.1. Therefore, we have inserted the phrase “* * * of Grade DOT-C2, DOT-C3, or DOT-C4 * * *” between the word “long” and the word “applied” in the first sentence making the language of the requirement faithful to that of paragraph S5.7.1.4.1(b) of the current version of FMVSS No. 108.

TTMA commented that certain tank trailers may not have a vertical surface suitable for installing the *Trailer side-alternating red and white materials* conspicuity material between 375 mm and 1525 mm above the road surface. If installed in a downward orientation, it would not be effective for its purpose. The requirement of this section states that the material must be installed in this height range if practicable and going beyond this range is permitted if it aids correct orientation. We believe that the language of paragraph S8.2.3.2.1 of the final rule, along with the illustrative examples of conspicuity treatment applied to tank trailers shown in Figure 11, adequately addresses this issue.

Paragraph S8.2.4 of the final rule contains the requirements for conspicuity systems installed on truck tractors, which was part of Table III in the NPRM. Paragraph S8.2.4.1 (split for clarity) contains requirements for Element 1 (alternating color) and paragraph S8.2.4.2 (split for clarity) states the requirements for Element 2

(white). One mounting alternative for conspicuity treatment requirements in *Truck tractor-Element 1* was inadvertently omitted from the NPRM. This material is allowed to be mounted to “plates attached to the mudflap support brackets” as stated in the current version of FMVSS No. 108 at paragraph S5.7.1.4.3(a). We have inserted this alternative mounting location after “mudflap support brackets” and before “or on the mudflaps” in paragraph S8.2.4.1.1 of the final rule.

S9 Associated Equipment Requirements

Section 7.14 of the NPRM, *Associated equipment requirements*, is relocated to paragraph S9 in the final rule.

Koito and Nissan commented that the first sentence of paragraph S7.14.1 of the NPRM, now paragraph S9.1.1 of the final rule, virtually duplicated the definition of *Turn signal operating unit* in S4. We agree and removed that sentence from paragraph S9.1.1. Paragraph S9.1.2 of the final rule states that turn signal operating units must meet the applicable performance requirements of paragraph S14.9. These references are to paragraph S6.6 and Table XXI in the NPRM.

Similarly, the first sentence of paragraph S7.14.2 of the NPRM, now paragraph S9.2.1 of the final rule, virtually duplicated the definition of *Turn signal flasher* in S4. We removed that sentence from paragraph S9.2.1. Paragraph S9.2.2 of the final rule states that turn signal flashers must meet the applicable performance requirements of paragraph S14.9. These references are to paragraph S6.6 and Table XXI in the NPRM.

In the NPRM, paragraph S7.14.3 stated requirements for the turn signal pilot indicator. These requirements have been relocated to paragraph S9.3 (split for clarity) in the final rule. Paragraph S7.14.3.1 of the NPRM described the turn signal pilot indicator size and color requirements. These requirements were erroneously based on paragraph 5.4.3 of SAE J588 NOV84, *Turn Signal Lamps for use on Motor Vehicles less than 2032 mm in Overall Width*. These requirements should have been based upon paragraph 4.5 of SAE J588e, *Turn Signal Lamps*, September 1970, as specified by paragraph S5.5.6 of the current version of FMVSS No. 108. We have stated the correct requirements in paragraph S9.3.4 of the final rule. These corrected requirements include a visibility requirement that references SAE J941b, *Motor Vehicle Driver's Eye Range*, February 1969, rather than the incorrect reference to SAE J1050,

Describing and Measuring the Driver's Field of View, which was included in the NPRM.

The incorporation in paragraph S7.14.3.2 of the NPRM of the language from the incorrect version of SAE J588 also caused the description of the modes of indication of the turn signal pilot indicator to be omitted as noted in the comments from AAM. We have corrected this in the final rule by inserting the phrase “* * *by a “steady on”, “steady off”, or by a significant change in the flashing rate* * *” into the text of paragraph S9.3.6.

We also neglected in the NPRM to cite the reason for our use of the failure indication criteria of “* * *minimum photometric performance specified in Tables VI or VII* * *” rather than the text of paragraph S5.5.6 of the current version of FMVSS No. 108, which states that criteria as “Failure of one or more turn signal lamps to operate* * *.” The language incorporated in the NPRM came from the July 10, 1998 letter of interpretation to Mr. Binder.²³ In that interpretation, the issue of how to indicate to the driver the failure of a turn signal lamp that consisted of a number of LED light sources was discussed. The failure indication criteria for this situation was stated in Binder in this way, “*If a light source fails in a turn signal lamp on a vehicle that is not equipped to tow a trailer, Standard No. 108 requires that the failure be indicated to the driver. We are not aware of any LED turn signals in use, or how manufacturers would design such a unit to comply with this requirement. However, we believe that a failure should be indicated to the driver at the point where an LED turn signal ceases to furnish the minimum photometric performance required by Standard No. 108.*” The statements in the Binder interpretation also apply to turn signal lamps using conventional incandescent light sources. If a turn signal lamp using an incandescent light source fails, it obviously has zero photometric output. Therefore, we adopted the language of Binder in the NPRM but omitted mention of it as one of the incorporated interpretations. We are correcting that omission here and are preserving the failure indication criteria of the NPRM in paragraph S9.3.6 of the final rule.

Paragraphs S7.14.4, *Headlamp beam switching device*, and S7.14.4.1, *Semi-automatic headlamp beam switching device*, of the NPRM, were re-designated as paragraphs S9.4 and S9.4.1, respectively, in the final rule. Paragraph S9.4.1.4 of the final rule, which was paragraph S7.14.4.1.4 in the NPRM, had

a second sentence added to it which states, “The device shall not affect the function of the upper beam indicator light.” which was inadvertently omitted from the NPRM. This requirement comes from paragraph 4.14 of SAE J565b, *Semiautomatic Headlamp Beam Switching Devices*, February 1969, which is incorporated by reference in the current version of FMVSS No. 108.

Paragraph S9.4.1.7 of the final rule states that semi-automatic headlamp beam switching devices must be designed to conform to the performance requirements of paragraph S14.9. These references are to paragraph S6.6 and Table XXI in the NPRM.

Paragraphs S7.14.5 *Upper beam headlamp indicator*, and S7.14.5.1 *Indicator size, location, and color*, of the NPRM, become paragraphs S9.5 and S9.5.1, respectively, in the final rule. However, the term “color” and the last sentence of paragraph S7.14.5.1 stating that the color of the indicator need not be red were deleted from paragraph S9.5.1. By removing this language and making Standard No. 108 silent about the color of the upper beam headlamp indicator, we have simplified the manner in which the requirement is presented. The current version of FMVSS No. 108 states in paragraph S5.5.2 that, “Each vehicle shall have a means for indicating to the driver when the upper beams of the headlamps are on that conforms to SAE Recommended Practice J564a, April 1964, except that the signal color need not be red”. The second paragraph of SAE J564a states that “* * *The upper beam indicator should consist of a red light* * *.” As noted in the comments of AAM, we incorporated in the NPRM the requirements of SAE J564a directly into the text of the Standard No. 108 without including the red color requirement because of the noted exclusion. However, we neglected to remove the excluding language from the NPRM. We are doing so in the final rule.

Koito and Nissan commented that the first sentence of paragraph S7.14.6 of the NPRM, now paragraph S9.6.1 of the final rule, virtually duplicated the definition of *Vehicular hazard warning signal operating unit* in S4. We agree and removed that sentence from paragraph S9.6.1. Paragraph S9.6.3 of the final rule states that vehicular hazard warning signal operating units must meet the applicable performance requirements of paragraph S14.9. These references are to paragraph S6.6 and Table XXI in the NPRM.

Similarly, the first sentence of paragraph S7.14.7 of the NPRM, now paragraph S9.7.1 of the final rule, virtually duplicated the definition of

Vehicular hazard warning signal flasher in S4. We removed that sentence from paragraph S9.7.1. Paragraph S9.7.2 of the final rule states that vehicular hazard warning signal flashers must meet the applicable performance requirements of paragraph S14.9. These references are to paragraph S6.6 and Table XXI in the NPRM.

Requirements for the vehicular hazard warning signal pilot indicator from paragraph S7.14.8 of the NPRM are relocated intact to paragraph S9.8 (split for clarity) in the final rule. AAM commented that a vehicular hazard warning signal pilot indicator was not required by FMVSS No. 108. We direct AAM's attention to SAE J910, *Vehicular Hazard Warning Signal Operating Unit*, January 1966, specifically paragraph 5. When we removed J910 as a referenced document in the NPRM, we incorporated the requirements of paragraph 5 into paragraph S7.14.8, which we are now designating as paragraph S9.8 in the final rule.²⁴

S10 Headlighting System Requirements.

The headlighting system requirements of S8 of the NPRM become S10 of the final rule.

Paragraph S8.1 of the NPRM is now paragraph S10.1 (split for clarity) in the final rule. Guide commented that paragraphs S8.1.1 and S8.1.2 of the NPRM were redundant with the requirement, of paragraph S8.1, that the headlighting system conforms to one of the systems of Table II. We agree and eliminated paragraphs S8.1.1 and S8.1.2 from the final rule.

We mentioned previously in the discussion of mounting location requirements that Guide commented that the content of sections 8.1.3 and 8.1.4 of the NPRM, dealing with headlamp beam mounting, was most appropriately located in the lamp mounting location section. We agree and have moved them intact to become paragraph S6.1.3.5 of the final rule.

Paragraph S8.1.5, *Headlamp adjustments*, of the NPRM was relocated to be paragraphs S10.18.1.1 and S10.18.1.2 of the final rule.

We adopted, in S10 of the final rule, the ASSN/AAM suggested standard format similar to that of the signal lamp and reflex reflector sections. Those standardized criteria that apply to headlamps with the appropriate

²⁴ SAE J945, *Vehicular Hazard Warning Signal Flasher*, February 1966 incorporated by reference in the current version of FMVSS No. 108 also discusses a visible pilot indicator for the vehicular hazard warning signal. The test condition requirement of S9.8.3 of the final rule comes from J945.

²³ <http://isearch.nhtsa.gov/files/18121.ztv.html>

pointing statements or “no requirement” notations become paragraphs S10.3 through S10.12 of the final rule.

The requirements for a sealed beam headlighting system, which were S9 of the NPRM, become paragraph S10.13 in the final rule. Paragraphs S9 and S9.1 of the NPRM have been relocated intact to become paragraphs S10.13 and S10.13.1 respectively in the final rule. The simultaneous aim requirements for type “F” sealed beam headlamps, which were paragraph S9.2 in the NPRM, become S10.13.2 in the final rule, the only revision being the revised reference for the applicable photometry procedure. Paragraph S9.3, *Photometry*, of the NPRM becomes paragraph S10.13.3 in the final rule, again with a revised reference to the photometry procedure. The physical tests requirements of paragraph S9.4 of the NPRM, which referenced Tables XXII and XXIII, become paragraph S10.13.4 (split for clarity) in the final rule, with updated references to the applicable test procedures and performance requirements in paragraph S14.

The requirements for an integral beam headlighting system that were paragraph S10 of the NPRM become paragraph S10.14 in the final rule. Paragraphs S10 and S10.1 of the NPRM have been relocated to be paragraphs S10.14 and S10.14.1, respectively, in the final rule, with the only revision being the substitution of the term “activated” for the term “mechanized” used in the NPRM. Paragraphs S10.2, S10.3, and S10.4 of the NPRM have been relocated to become paragraphs S10.14.2 (split for clarity), S10.14.3, and S10.14.4 respectively in the final rule.

AAM and Koito both commented that the language in paragraph S10.5 (repeated in paragraph S11.3) of the NPRM, stating that, “An integral beam (replaceable bulb in paragraph S11.3) headlamp may incorporate replaceable light sources that are used for purposes other than headlighting”, could be interpreted to mean those “replaceable light sources” defined in S4 of the NPRM. This language came from paragraphs S7.4(i) and S7.5(j) of the current version of Standard No. 108. To alleviate concerns that this incorrect interpretation could be applied, we have revised the language of paragraph S10.5 (and paragraph S11.3) of the NPRM. Paragraph S10.14.5 (and paragraph S10.15.5) of the final rule now states, “An integral beam (replaceable bulb in paragraph S10.15.5) headlamp may incorporate light sources that are used for purposes other than headlighting and are capable of being replaced.”

Paragraph S10.6, *Photometry*, of the NPRM becomes paragraph S10.14.6 in the final rule, with a revised reference to the photometry procedure. The physical test requirements of paragraph S10.7 of the NPRM, which referenced Table XXII and Table XXIII, become paragraph S10.14.7 (split for clarity) in the final rule, with updated references to the applicable test procedures and performance requirements in paragraph S14.

The requirements for a replaceable bulb headlighting system, which were paragraph S11 of the NPRM, become paragraph S10.15 in the final rule. Paragraph S11 of the NPRM has been relocated intact to be paragraph S10.15 in the final rule. Koito commented that the language of paragraph S11.1 of the NPRM stating, “* * * must consist of the correct number of designated headlamp units shown for* * *” did not clearly express the requirement. We agree and have revised this phrase to, “* * * must consist of either two or four headlamps shown for* * *” in paragraph S10.15.1 of the final rule.

Paragraph S11.2 of the NPRM becomes paragraph S10.15.2 in the final rule. Paragraph S11.4 of the NPRM has the phrase “* * * be designed to* * *” inserted before the word “conform” when it becomes paragraph S10.15.3 of the final rule.

Paragraph S11.5 of the NPRM is relocated to become paragraph S10.14.4.1 of the final rule. It is supplemented by a new paragraph S10.15.4.2 stating the exception from the requirements of paragraph S10.14.4.1 (that were contained in paragraphs S7.5(d)(3)(i)(A) and S7.5(d)(3)(ii)(A) of the current version of FMVSS No. 108), which was omitted from the NPRM, as noted in the comments of Guide and Koito.

As previously mentioned, paragraph S11.3 of the NPRM was revised for clarity and becomes paragraph S10.15.5 in the final rule.

Paragraph S11.6, *Photometry*, of the NPRM becomes paragraph S10.15.6 in the final rule, with a revised reference to the photometry procedure. The physical tests requirement of paragraph S11.7 of the NPRM, which referenced Table XXII and Table XXIII, becomes paragraph S10.15.7 (split for clarity) in the final rule, with updated references to the applicable test procedures and performance requirements in paragraph S14.

The requirements for a combination headlighting system that were S12 of the NPRM become paragraph S10.16 in the final rule. Paragraphs S12 and S12.1 of the NPRM have been relocated to be paragraphs S10.16 and S10.16.1,

respectively, in the final rule, with the only revision being the substitution of the term “activated” for the term “mechanized” used in the NPRM.

Paragraph S12.2, *Photometry*, of the NPRM becomes paragraph S10.16.2 in the final rule, with a revised reference to the photometry procedure. The physical test requirements of paragraph S12.3 of the NPRM, which referenced Table XXII and Table XXIII, become paragraph S10.16.3 (split for clarity) in the final rule, with updated references to the applicable test procedures and performance requirements in paragraph S14.

The requirements for a motorcycle headlighting system that were S13 of the NPRM become paragraph S10.17 in the final rule. Paragraphs S13.1, S13.1.1 (split for clarity), S13.1.2 (split for clarity), and S13.1.3 (split for clarity) of the NPRM are relocated intact to become paragraphs S10.17.1, S10.17.1.1, S10.17.1.2, and S10.17.1.3, respectively, of the final rule. Paragraph S13.4 of the NPRM becomes paragraph S10.17.2 of the final rule.

Paragraph S13.2, *Photometry*, of the NPRM becomes paragraph S10.17.3 in the final rule, with a revised reference to the photometry procedure. The physical test requirements of paragraph S13.3 of the NPRM, which referenced Table XXII, become paragraph S10.17.5 in the final rule, with updated references to the applicable test procedures and performance requirements in paragraph S14.

Paragraphs S13.5.1, *Modulation*, S13.5.2, *Replacement modulators*, S13.5.2.1, *Replacement performance*, and S13.5.2.2, *Replacement instructions*, of the NPRM are relocated intact to become paragraphs S10.17.5.1, S10.17.5.2, S10.17.5.2.1, and S10.17.5.2.2, respectively, in the final rule.

Headlamp aimability requirements that were located in S14 in the NPRM have been relocated to paragraph S10.18 in the final rule with one exception and with very few revisions. The exception is proposed paragraph S14.2 dealing with equipment in front of a headlamp lens. The requirements of this section were moved to paragraph S6.2.6 in the *Impairment* section of the final rule.

Paragraph S14.8.2 of the NPRM, which becomes paragraph S10.18.7.2 of the final rule, contains requirements for use of nonadjustable headlamp aiming device locating plates for five types of sealed beam headlamps. The language in the NPRM stated that these units should incorporate lens-mounted aiming pads specified in Figures a, b, c, d, or e of the NPRM. The figures referred to were intended to be placeholders in

a draft version of the NPRM. The NPRM should have stated that, “* * * incorporate lens-mounted aiming pads as specified for those units in Appendix C of part 564 of this chapter,” which is incorporated in paragraph S10.18.7.2 of the final rule.

Koito requested that an alternative measurement distance of 25 m be permitted for the measurement of the cutoff parameter for a visually/optically aimed headlamp. Paragraph S14.10.1.5 of the NPRM, based upon the April 6, 2000 letter of interpretation to Mr. Spingler,²⁵ required the measurement distance to be 10 m. One of the objectives of the rewrite of Standard No. 108 is to improve the clarity of the document without changing the substance of the existing requirements. The referenced letter of interpretation states a specific measurement distance without alternatives. Therefore, Koito's request would be a substantive change beyond the scope of the rewrite and paragraph S10.18.9.1.5 of the final rule duplicates the requirement from the NPRM.

S11 Replaceable Light Source Requirements

Paragraph S15 of the NPRM, *Replaceable light source requirements*, is relocated to S11 in the final rule. Paragraphs S15 and S15.1 from the NPRM become paragraphs S11 and S11.1, respectively, in the final rule. Paragraph S15.4, *Ballast markings*, of the NPRM becomes paragraph S11.2 in the final rule and paragraph S15.5, *Gas discharge laboratory life*, becomes paragraph S11.3. Paragraph S15.6 of the NPRM, containing requirements for physical tests of replaceable light sources, is split into paragraphs S11.4.1 and S11.4.2 in the final rule. Paragraph S11.4.1 references the deflection test and pressure test applicable to replaceable light sources, which were part of Table XXIII in the NPRM and have been relocated to paragraph S14.7 in the final rule. Paragraph S11.4.2 references a restated power and flux measurement test that is described in paragraph S14.7.3 of the final rule, noting that the performance requirements for this test do not reside in the main text of Standard No. 108, but in the applicable appendix of part 564 of this chapter.

The NPRM contained paragraphs S15.2 and S15.3, both titled *Power and flux measurement*, which essentially described the same test of replaceable light sources. Recognizing that they were test procedures and striving to advance the objectives of the rewrite, we

consolidated the procedures of paragraphs S15.2 and 15.3 into a single procedure, without revising or modifying the requirements, and relocated it to paragraph S14.7.3 of the final rule.

S12 Headlamp Concealment Device Requirements

The headlamp concealment device requirements of S16 of the NPRM are relocated intact to S12 of the final rule.

S13 Replaceable Headlamp Lens Requirements

The replaceable headlamp lens requirements of paragraph S18 of the NPRM are relocated intact (split for clarity) to paragraph S13 of the final rule.

S14 Physical and Photometry Test Procedures and Performance Requirements

As previously mentioned, ASSN/AAM and Grote commented that tables containing significant amounts of text, such as the test requirements in Tables XXI, XXII, and XXIII of the NPRM, are difficult to use because of lengthy passages that contain several sentences and express several unique test conditions or requirements. We agree with these comments. In the final rule, we have moved virtually all test procedures and their associated performance requirements to S14.

General test procedures and performance requirements that were located in paragraph S6.8 of the NPRM have been placed in paragraph S14.1 of the final rule. Similarly, the photometric test procedures of paragraph S6.8 of the NPRM are now paragraph S14.2 of the final rule.

Part of Table XXII of the NPRM, the out of focus test applicable to motorcycle headlamps designed to conform to paragraph S10.17(b), becomes paragraph S14.3 in the final rule. The color test and plastic optical materials test of Table XXII become paragraph S14.4 in the final rule. The remaining tests of Table XXII, the vibration test, moisture test, dust test, and corrosion test, become paragraph S14.5 in the final rule.

All tests applicable to complete headlamps included in Table XXIII of the NPRM have been relocated to paragraph S14.6 of the final rule. The tests in Table XXIII of the NPRM related to replaceable light sources become paragraph S14.7 in the final rule. Tests in Table XXIII of the NPRM that apply to vehicle headlamp aiming devices (VHAD) were relocated to be paragraph S14.8 in the final rule. Also, the tests applicable to associated equipment that

were located in Table XXI of the NPRM become paragraph S14.9 in the final rule.

S6.8.1 of the NPRM, stating that lamps, reflective devices, and associated equipment regulated by Standard No. 108 be designed to conform to applicable physical test requirements, becomes paragraph S14.1.1 of the final rule. This is followed by proposed paragraphs S6.8.4 and S.8.4.1 of the NPRM, applicable to plastic optical materials, which become paragraphs S14.1.2 and S14.1.3, respectively, in the final rule. Bayer had asked that the word “reflex” be placed before the word “reflector” in paragraph S14.1.2 but we prefer to keep the language faithful to paragraph S5.1.2 of the current version of Standard No. 108. Paragraph S14.1.4, *Samples*, of the final rule is paragraph S6.8.2 (split for clarity) of the NPRM, except for the sentence “A mounting bracket with a sample headlamp installed must not have a resonant frequency in the 10–55 Hz. range” which was relocated to paragraph S14.6.8.1 in the final rule because of its specific applicability to the vibration test for headlamps. Paragraph S6.8.3 of the NPRM is now paragraph S14.1.5 of the final rule.

Paragraph S6.8.5 of the NPRM becomes paragraph S14.2, *Photometric test procedures*, in the final rule. Paragraph S6.8.5.1 was split for clarity and becomes paragraph S14.2.1 in the final rule. Nissan commented that the measurement distance requirements in paragraph S6.8.5.1 were confusing because they mentioned license plate lamps and headlamps. We agree and have revised the text of paragraph S14.2.1.3 of the final rule to expressly state the required distance for all lamps that paragraph S14.2.1 applies to. Nissan also noted that proposed paragraph S6.8.5.1 contained a requirement for photometric intensity between test points that was duplicated in several photometry requirements tables as a footnote. We eliminated this language from paragraph S14.2.1 of the final rule, deciding that the individual requirements tables were the appropriate location for the intensity between test point requirements.

Paragraph S6.8.5.1.1 of the NPRM becomes, in its entirety, paragraph S14.2.1.4 (split for clarity) of the final rule. Paragraph S6.8.5.1.2, detailing requirements for photometry of multiple compartment lamps and multiple lamps, becomes paragraph S14.2.1.5 in the final rule. We adopted the suggestion of Koito to specifically indicate the type of lamps to which this section applies.

²⁵ <http://isearch.nhtsa.gov/files/21406.ztv.html>

Paragraph S6.8.5.2 of the NPRM becomes paragraph S14.2.1.6 (split for clarity) in the final rule. Paragraph S14.2.1.6.2 was added to this section at the suggestion of Calcoast, which observed that the NPRM had not included the content of Footnotes 2 and 3, which follow Table IV, of the current version of FMVSS No. 108. The last sentence of paragraph S6.8.2, which specifically addressed samples for the color test of reflex reflectors, was moved to be paragraph S14.4.1.1 of the final rule.

Paragraph S6.8.5.3, *License plate lamp photometry*, of the NPRM becomes paragraph S14.2.2 in the final rule. Paragraphs S6.8.5.3.1 and S6.8.5.3.2 of the NPRM become paragraphs S14.2.2.1 and S14.2.2.2, respectively, in the final rule. Nissan observed that the language of paragraph S6.8.5.3.2 was awkward and suggested a revision that did not change the substance of the requirement. We adopted Nissan's suggestion in paragraph S14.2.2.2. We also added paragraph S14.2.2.3 to the final rule to clarify that the bulb requirements of paragraph S14.2.1.6 also apply to license plate lamp photometry.

Proposed paragraph S6.8.5.4, stating requirements for reflex reflector and retroreflective sheeting photometry, becomes paragraph S14.2.3 in the final rule. For clarity, paragraph S6.8.5.4 of the NPRM has been split into paragraphs S14.2.3.1 through S14.2.3.6 and paragraph S6.8.5.4.1 has been split into paragraphs S14.2.3.7.1 through S14.2.3.8.2 in the final rule. Likewise, paragraph S6.8.5.4.1.1 in the NPRM becomes paragraph S14.2.3.8.3.1 in the final rule.

3M commented that the language of paragraph S6.8.5.4.1 of the NPRM, which is paragraph S14.2.3.7 of the final rule, did not allow a complete photometric evaluation of retroreflective sheeting because a presentation angle was not specified. 3M's premise was that the test method of the current version of FMVSS No. 108 relies on conventions regarding orientation and presentation that are part of ASTM E 810, *Standard Test Method for Coefficient of Retroreflection of Retroreflective Sheeting Utilizing the Coplaner Geometry*, which is referenced by ASTM D 4956, *Standard Specification for Retroreflective Sheeting for Traffic Control*, a document 3M contends is no longer referenced in the NPRM. This contention is incorrect. The reference to ASTM D 4956, from paragraph S5.7.1.2 of the current version of FMVSS No. 108, is replicated in paragraph S7.12.1 of the NPRM and finally by paragraph S8.2.1.2 of the final

rule, with consistent language throughout. Since the connection to ASTM E 810 still exists, we see no reason to modify the final rule as 3M suggested.

Nissan suggested that the language concerning the mounting of a reflex test sample for photometry, which becomes paragraph S14.2.3.1 of the final rule, did not allow for a test chamber which does not provide a linear 100 foot test distance, but rather was arranged in a non-horizontal orientation. We do not agree and, therefore, have not changed the text from the NPRM to the final rule. The procedure of paragraph S14.2.3.1 is faithful to the language of paragraph 3.1.7 of SAE J594f, *Reflex Reflectors*, January 1977, incorporated by reference in the current version of FMVSS 108.

The reflex reflector photometry test, like all tests in Standard No. 108, describes a procedure that NHTSA would use to test a reflex reflector for purposes of compliance. It also describes the performance requirements that the reflector must be designed to conform to, when tested according to the procedure. If a manufacturer chooses to use a procedure that differs with that described in FMVSS No. 108 as its basis of compliance, or to establish a basis of compliance that does not rely on an actual test, it is free to do so. However, the manufacturer must exercise due care in designing its product to conform to the performance requirements of all applicable tests in Standard No. 108 when tested according to the procedures stated in the standard.

Paragraph S6.8.5.5, *Daytime running lamp (DRL) photometry measurements*, of the NPRM becomes paragraph S14.2.4 (split for clarity) of the final rule. Paragraph S14.2.4.3 was added to the final rule to clarify that the bulb requirements of paragraph S14.2.1.6 also apply to DRL photometry.

Nissan expressed some confusion regarding how a dedicated DRL, without any equipment that alters or conditions the voltage, should have power applied to it for photometric testing as stated in paragraph S14.2.4. We are unable to answer this question as part of the rewrite process and note Nissan can request an interpretation for this specific situation.

Paragraph S6.8.5.6 of the NPRM, covering photometry measurements of headlamps, becomes paragraph S14.2.5 in the final rule. Some rearrangement of content and splitting of sections for clarity was incorporated into the final rule. Specifically, paragraph S14.2.5.1 of the final rule contains the first sentence of paragraph S6.8.5.6 of the NPRM, paragraph S14.2.5.2 contains the last sentence of paragraph S6.8.5.6.5,

paragraph S14.2.5.3 contains the last sentence of paragraph S6.8.5.6, paragraph S14.2.5.4 duplicates paragraph S6.8.5.6.1, paragraph S14.2.5.5 duplicates paragraph S6.8.5.6.2, paragraphs S14.2.5.5.1 and S14.2.5.5.2 duplicate paragraphs S6.8.5.6.2(a) and S6.8.5.6.2(b) respectively, paragraph S14.2.5.5.3 (split for clarity) duplicates paragraph S6.8.5.6.2(c), paragraph S14.2.5.5.4 duplicates paragraph S6.8.5.6.2(d), paragraph S14.2.5.5.5 (split for clarity) duplicates paragraph S6.8.5.6.2(e), paragraph S14.2.5.5.6 (split for clarity) duplicates paragraph S6.8.5.6.2(f), paragraph S14.2.5.5.7 (split for clarity) duplicates paragraph S6.8.5.6.2(g), paragraph S14.2.5.5.8 duplicates paragraph S6.8.5.6.2(i), and paragraph S14.2.5.5.9 duplicates paragraph S6.8.5.6.2(j). Paragraph S6.8.5.6.2 of the NPRM becomes paragraph S14.2.5.6 of the final rule, paragraph S6.8.5.6.4 becomes paragraph S14.2.5.7 (split for clarity), paragraph S6.8.5.6.5 (less the last sentence) becomes paragraph S14.2.5.8 (split for clarity), and paragraph S6.8.5.6.6 becomes paragraph S14.2.5.9. Guide commented that paragraph S6.8.5.6.2(h) of the NPRM described photometry measurement for moveable reflector headlamps rather than an aiming procedure and did not belong where it was located. We agree and have designated this provision as paragraph S14.2.5.10 in the final rule.

AAM and Honda objected to the word "specified" which appeared before "position relative to the * * *" in the NPRM. We omitted "specified" in the final rule to be faithful to paragraph S7.8.2.2(b) of the current version of FMVSS No. 108. We also added a horizontal range exclusion for visually/optically aimed moveable reflector headlamps with a fixed horizontal aim to be faithful to paragraph S7.8.2.2(d) of the current version of FMVSS No. 108, as noted in the comments of Nissan.

Paragraph S14.3 of the final rule contains the out of focus test that was part of Table XXII of the NPRM. This test only applies to motorcycle headlamps that are designed to conform to paragraph S10.17(b) of the final rule. AAM identified two typographical errors in the out of focus test procedure where there were no periods after the abbreviations "in". Our practice is to not include a period after such abbreviations, so the text identified by AAM is correct although in several other instances we did include a period after such an abbreviation. In the final rule we have removed periods after all such abbreviations, except in those situations where other grammatical

requirements, such as the end of a sentence, require a period.

Paragraph S14.4 of the final rule, *General test procedures and performance requirements*, contains the color test and plastic optical materials test, along with applicable requirements, from Table XXII of the NPRM. In both tests, the text as stated in the NPRM has been split for clarity in the final rule.

AAM noted that the Scope of SAE J578c, *Color Specification for Electric Signal Lighting Devices*, February 1977, contains limitations on the application of this standard that may be important to lighting manufacturers. This portion of SAE J578c was inadvertently left out of Table XXII in the NPRM. In the final rule, we have added it as paragraph S14.4.1. This section will now read, "The requirement applies to the overall effective color of light emitted by the device and not to the color of the light from a small area of the lens. It does not apply to any pilot, indicator, or tell-tale lights. The color of the sample device * * *

Paragraph S14.4.1.1 of the final rule, detailing alternatives for samples used in the color test of reflex reflectors, originated from the last sentence of paragraph S6.8.2 of the NPRM.

Koito, 3M, and Honda commented that the language of the performance requirement for the color test for the color yellow using the visual evaluation method omitted a key word. In the NPRM, the requirement is stated as, "*Yellow (Amber)* is acceptable if it is less saturated (paler), greener, or redder than the limit standard." The revised text in the final rule states, "*Yellow (Amber)* is not acceptable if it is less saturated (paler), greener, or redder than the limit standard" [emphasis added].

AAM commented that the color restricted blue should be included in the final rule because it appears in SAE J578c. We know of no requirements in Standard No. 108 for the light from a lamp or the color of a lens material to be restricted blue. We also observed that there are also no such requirements for the colors green or blue. Therefore, we have not only decided against adding requirements for restricted blue but also have removed the requirements for the colors blue and green for both the visual evaluation method and the tristimulus evaluation method of the color test of paragraph S14.4.1 in the final rule.

AAM commented that Section 3.2, *Tristimulus Method*, from SAE J578c is not stated in its entirety in the procedure column of the color test of proposed Table XXII. We have reviewed SAE J578c and the text of the *Tristimulus Method* procedure from

proposed Table XXII. We do not find that the text of proposed Table XXII omitted any substantive portion of SAE J578c that describes how the test is performed. In the absence of any specific explanation of its comments by AAM, we are not revising the *Tristimulus Method* section, now located in paragraph S14.4.1.4 of the final rule.

Paragraph S14.4.2 of the final rule contains the plastic optical materials tests from Table XXII of the NPRM. Atlas, Bayer, Grote, and AAM commented that the performance requirement for headlamp lens materials after the outdoor exposure test portion of the plastic optical materials tests in Table XXII of the NPRM was not identical to that stated in Section 4.2.3 of SAE J576 JUL91. The language of the NPRM stated that the requirement was no haze greater than 0% when measured by ASTM D 1033 (1992). SAE J576 JUL91 states the requirement as "shall show no deterioration."

Koito noted that while the measurement method of ASTM D 1033 (1992) was required for evaluation of the post exposure haze of other materials, it was not required for the evaluation of headlamps. Koito also stated that the post exposure performance requirements for luminous transmittance and color required by SAE J576 at Sections 4.2.1 and 4.2.2 are missing from the NPRM. We agree with these comments and have revised the plastic optical materials test outdoor exposure test portion performance requirements accordingly. Specifically, the performance requirement section for headlamp lenses, now paragraph S14.4.2.2.4.2 of the final rule, no longer requires evaluation by ASTM D 1033 (1992) and states, "After completion of the outdoor exposure test, materials used for headlamp lenses must show no deterioration." The performance requirement section for luminous transmittance, now paragraph S14.4.2.2.4.4, states, "After completion of the outdoor exposure test, all materials, when compared with the unexposed control samples, must not have their luminous transmittance changed by more than 25% when tested in accordance with ASTM E 308-66 (1973) using CIE Illuminant A (2856K)." The performance requirement section for color, now paragraph S14.4.2.2.4.5, states, "After completion of the outdoor exposure test, all materials must conform to the color test of this standard in the range of thickness stated by the material manufacturer."

Bayer stated that specifying 2.3 mm thick test samples for the plastic optical materials tests represents a change from

the current version of FMVSS No. 108 and may increase the testing burden of the industry. We do not believe that specifying 2.3 mm thick samples is a change from current requirements. SAE J576 JUL91 does only suggest 2.3 mm samples, paragraph S5.2.1 of the current version of FMVSS No. 108 (and paragraph S5.1 of the NPRM) states that, "The words 'It is recommended that', 'recommendations', or 'should be' appearing in any SAE Standard or Recommended Practice referenced or subreferenced by this standard shall be read as setting forth mandatory requirements * * *" We consider the term "suggest" to have a similar meaning as the term "should be" and have therefore included 2.3 mm as one of the sample thicknesses used for the plastic optical material test. We believe there is value in specifying sample thickness. The inclusion of the 2.3 mm sample thickness also serves to alert regulated parties that should the agency choose to perform a compliance test, it will perform the test on this sample thickness.

AAM suggested eliminating the notation concerning test samples having 32 sq cm of exposed area from the *Procedure* column of Table XXII of the NPRM and allowing it to remain in the *Samples* column of the outdoor exposure test portion of the plastic optical materials tests. We do not agree with this suggestion. The area requirement is important in both the preparation of the samples and their mounting orientation for the exposure test. An area specification is appropriate in both places and is included in both paragraph S14.4.2.1.2 and paragraph S14.4.2.2.3.1 of the final rule.

The NPRM omitted the third sentence of SAE J576 JUL91 Section 3.3.2 requiring that samples be mounted in the open with a minimum 30 cm (11.8 in) separation from their background. This has been corrected in the final rule by including the separation requirement in paragraph S14.4.2.2.3.1.

AAM suggested that content of the *Samples* column of Table XXII of the NPRM for the outdoor exposure test portion of the plastic optical material tests be repeated for the heat test portion separately. We agree that this would add clarity. We have revised the heat test portion of the plastic optical materials tests to appear as a test separate from the outdoor exposure test and have placed content specific to the heat test into paragraph S14.4.2.3 of the final rule.

Paragraph S14.5 of the final rule, *Signal lamp and reflective device test procedures and performance requirements*, contains the vibration,

moisture, dust, and corrosion tests that were located in Table XXII of the NPRM.

As previously mentioned, the references in the NPRM to SAE J577, *Vibration Test Machine*, April 1964, have been eliminated in the final rule with the incorporation of the drawing and mechanical details of the vibration machine as Figure 21. The reference in the vibration test procedure to SAE J577 has been revised to Figure 21 in paragraph S14.5.1.1 of the final rule.

AAM, Honda, and Guide commented about the inadvertent omission of the phrase "one hour" from the moisture test procedure of Table XXII of the NPRM. This is corrected in the final rule where paragraph S14.5.2.1, second sentence, states, "* * * followed by a one hour drain period * * *"

We have decided that the first sentence of the moisture test performance requirements of the NPRM stating, "After completion of the moisture test * * *" is more appropriately part of the test procedure. Therefore, we are relocating it to be the last sentence of paragraph S14.5.2.1 of the final rule.

Calcoast commented that the moisture test performance requirement for a sealed reflex unit stated in SAE J594f, January 1977, at Section 3.1.4 is "any visible moisture constitutes a failure." We agree and have revised the moisture test performance requirements of paragraph S14.5.2.2 in the final rule to state "Accumulation of moisture in excess of 2 cc, or any visible moisture in a sealed reflex unit, must constitute a failure."

AAM noted that the dust test of Table XXII of the NPRM is not required to be performed on sealed units per SAE J575d, August 1967, Section G, and SAE J575e, August 1970, Section G. We agree and in the final rule paragraph S14.5.3.1, *Samples* states, "A sealed unit is not required to meet the requirements of this test." We also decided that the first sentence of the performance requirements of the dust test stating, "After completion of the dust test the exterior surface of the device must be cleaned" was part of the test procedure rather than a performance requirement so that sentence was moved to paragraph S14.5.3.2 in the final rule.

Paragraph S14.6 of the final rule, *Headlamp physical test procedures and performance requirements*, consists of all headlamp test procedures from Table XXIII of the NPRM, except for those that apply specifically to replaceable light sources or vehicle headlamp aiming devices (VHAD). Several of the tests that become paragraph S14.6 had significant

portions of their text split for clarity as part of their relocation from Table XXIII of the NPRM to paragraph S14.6 of the final rule. These tests include: (1) Abrasion test, (2) chemical resistance test, (3) corrosion connector test, (4) dust test, (5) temperature cycle test, (6) internal heat test, (7) humidity test, (8) sealing test, (9) chemical resistance of reflectors of replaceable lens headlamps, (10) corrosion resistance of reflectors of replaceable lens headlamps, (11) torque deflection test, and (12) both aiming adjustment tests.

Honda commented that the pad cycling rate of the abrasion test procedure of Table XXIII of the NPRM contained typographical errors. We agree and have revised the text in paragraph S14.6.1.1.3 of the final rule from "11 cycles at $10 \pm \text{cm}$ per second * * *" to the correct language from the current version of FMVSS No. 108 paragraph S8.2(b) which is, "* * * 11 cycles at 4 ± 0.8 in (10 ± 2 cm) per second * * *"

AAM stated the requirement that the same sample headlamp be used in both the temperature cycle test and the internal heat test was not supported in the current version of FMVSS No. 108. We disagree. The current version of Standard No. 108 states, concerning integral beam headlamps at paragraph S7.4(h)(5), "The headlamp shall meet the requirements of subparagraph (i) and then those of subparagraph (ii) [emphasis added]. Subparagraph (i) describes a temperature cycle test in accordance with paragraph S8.6.1 and subparagraph (ii) describes an internal heat test in accordance with paragraph S8.6.2. Paragraph S7.5(h)(i) requires replaceable bulb headlamps to meet the same physical tests in paragraphs 7.4(g) and S7.4(h) that are required of an integral beam headlamp. Thus, there is a very clear requirement that a single headlamp sample be used, in sequence, in the temperature cycle test and then the internal heat test.

Guide and VS commented that the humidity test of Table XXIII of the NPRM incorrectly included a performance requirement of post-test photometry. We agree, and the post-test photometry provision has been removed from the humidity test, which is contained in paragraph S14.6.7.2 of the final rule.

Honda and AAM observed a typographical error in the tolerance for air flow uniformity in paragraph (d) of the humidity test procedure. The text of the NPRM states, "* * * each grid point is 10% of the average * * *" while the corrected text of paragraph S14.6.7.1.6 of the final rule states, "* * * each grid point is $\pm 10\%$ of the average * * *"

which is faithful to paragraph S8.7(d) of the current version of FMVSS No. 108.

As we mentioned in the discussion of paragraph S14.5, the references in the NPRM to SAE J577, *Vibration Test Machine*, April 1964, have been eliminated in the final rule with the incorporation of the drawing and mechanical details of the machine as Figure 21. The reference in the vibration test procedure of Table XXIII of the NPRM to SAE J577 has been revised to Figure 21 in the final rule.

Nissan observed that the applicability of the chemical resistance of reflectors of replaceable lens headlamps test and the corrosion resistance of reflectors of replaceable lens headlamps test did not include integral beam headlamps, as required by paragraph S5.8.11 of the current version of FMVSS No. 108. Its comment is correct and paragraph S10.14.7.6 of the final rule correctly states the requirement for these two tests.

Koito and Nissan questioned whether the inward force test of Table XXIII applied to headlamps other than sealed beams, particularly those headlamps that utilize a VHAD or are visually/optically aimed. This requirement comes from paragraph S7.8.5.1(b) of the current version of FMVSS No. 108. That paragraph states, "when a headlamp is installed on a motor vehicle, its aim in any direction shall not change by more than 0.30 degree nor shall the lamp recede more than 0.1 in (2.5 mm) after being subjected to an inward force of 50 pounds (222 newtons) applied evenly to the lens parallel to the mechanical axis." There is no distinction in this paragraph to any particular type of headlamp, so it must be applied to all headlamps.

Nissan commented that the performance requirements of the aiming adjustment test (laboratory) were "difficult to read" as presented but did not explain the difficulties or suggest alternative language. In the final rule, we have split the performance requirements of this test into paragraphs S14.6.17.2.1, S14.6.17.2.2, and S14.6.17.2.3, which we believe will improve clarity.

Paragraph S14.7 of the final rule, *Replaceable light source physical test procedures and performance requirements*, consists of the deflection test for replaceable light sources and the pressure test for replaceable light sources from Table XXIII of the NPRM, along with a replaceable light source power and flux measurement procedure. The text of all of these items has been split for clarity in the final rule. There were no comments submitted that impacted the substance of these

procedures and requirements. However as mentioned in the discussion of paragraph S11, the NPRM contained paragraphs S15.2 and S15.3, both titled *Power and flux measurement*, that essentially described the same test of replaceable light sources. We consolidated the procedures of paragraphs S15.2 and S15.3 into a single procedure, without revising or modifying the requirements, and relocated it to paragraph S14.7.3 of the final rule.

Paragraph S14.8 of the final rule, *Vehicle headlamp aiming device (VHAD) physical test procedures and performance requirements*, consists of the six VHAD tests that were part of Table XXIII of the NPRM. There were no comments submitted that impacted the substance of these procedures and requirements.

Paragraph S14.9 of the final rule, *Associated equipment physical test procedures and performance requirements*, consists of the tests contained in Table XXI of the NPRM. These test procedures and performance requirements, as written in Table XXI of the NPRM, were in block paragraph form. As we have done in several places throughout the final rule, we have split some of these longer paragraphs into several smaller sections, which are grouped according to similar content, in an effort to improve clarity.

One of the goals of the FMVSS No. 108 rewrite was to remove outdated requirements from the document. The physical test requirements for associated equipment presented an opportunity to pursue this goal. The applicable SAE documents incorporated by reference in FMVSS No. 108 were adopted between 1964 and 1969 and several of them contained specifications for both vehicles with a nominal 12 volt electrical system as well as those with a nominal 6 volt electrical system. Believing that few, if any, vehicles manufactured after the effective date of FMVSS No. 108 have been equipped with a nominal 6 volt electrical system, we deleted references to that voltage in the proposal.

In its comments, AAM requested that we restore the nominal 6 volt requirements to the physical test requirements for associated equipment. Presumably, this comment was based upon the knowledge that one of its constituent organizations was producing a 6 volt device for a regulated vehicle or had plans to do so. While we continue to believe that those requirements are not currently being used by any regulated party, we do not want to eliminate a compliance option that has value. Therefore, we have

restored the applicable language from the SAE documents²⁶ incorporated by reference in the current version of FMVSS No. 108 for testing devices used in a nominal 6 volt electrical system. The restoration of nominal 6 volt requirements necessitated revisions in the following portions of paragraph S14.9 of the final rule: (1) S14.9.1 turn signal operating unit durability test procedure, (2) S14.9.2.2 vehicular hazard warning signal operating unit durability performance requirements, and (3) S14.9.3 turn signal flasher and vehicular hazard warning signal flasher test procedure and performance requirements.

AAM and Honda commented that the reference in the turn signal operating unit durability test procedure in Table XXI of the NPRM incorrectly stated the ripple voltage tolerance of the power supply. We agree and have revised the language of that procedure in the final rule. The text “* * * ripple voltage of less than 5% * * *” was changed to “* * * ripple voltage of not more than 5% * * *.”

The turn signal flasher and vehicular hazard warning signal flasher both maintained their reference to SAE J823b, *Flasher Test Equipment*, April 1968, in the NPRM. As previously mentioned, this document was eliminated from the final rule by incorporating its content directly into Standard No. 108. This was accomplished in the final rule by creating Figure 22, *Flasher Standard Test Circuit*, for the circuit diagram of Figure 1 of SAE J823b, and also by listing the test setup requirements of Sections 3 through 9 of SAE J823b in paragraph S14.9.3 of the final rule as well as the power supply specifications for testing performance requirements and those specifications for testing durability requirements that were Section 10 of SAE J823b into paragraph S14.9.3.2 of the final rule.

Koito commented on the load requirements (from paragraph S5.1.1.19 of the current version of FMVSS No. 108) for variable load turn signal flashers for the turn signal flasher starting time test and the flash rate and percent current “on” time test. In the proposal, this information was located parenthetically after the notation “Starting time test” and “Flash rate and percent current “on” time test”. We agree with Koito that this is not the

optimum location for this provision, and have inserted it into the applicable test procedure in the final rule. Where those proposed procedures stated “* * * with the design load connected * * *” the text of the final rule now states “* * * with the design load (variable load flashers are tested with their minimum and their maximum design load) connected * * *.”

Koito and AAM observed that load specifications stated in the procedure for the turn signal flasher voltage drop test and durability test procedures did not clearly replicate the requirements from paragraph S5.1.1.19 of the current version of FMVSS No. 108, and SAE J590b, October 1965, Section 2. We have revised the language of those procedures in the final rule to clarify the load specifications. The proposed procedures stated “* * * with the maximum design load connected * * *” which has changed in the final rule to state “* * * with the design load (variable load flashers are tested with their maximum design load) connected * * *.”

Honda observed that the durability test performance requirements for the vehicular hazard warning signal flasher did not include the notation from SAE J945, February 1966, Section 7, requiring the post durability test to incorporate pilot lamps as part of the maximum design load. We agree and have revised the language of the performance requirements in paragraph S14.9.3.10.3 of the final rule from “* * * maximum design load at an ambient * * *” to “maximum design load, including pilot lamps as specified by the manufacturer, at an ambient* * *.”

Honda, AAM, and Koito all commented that the column headings for the semiautomatic headlamp beam switching device sensitivity test performance requirements were incorrect. We agree and have revised them in paragraph S14.9.3.11.2.3.1 of the final rule. They now read from left to right: Test position (degrees) [above the two columns of lateral and vertical test points], Dim (cd at 100 ft), and Hold (cd at 100 ft).

Honda observed that the maximum dim sensitivity at test point H-5R was incorrectly stated in the NPRM as 100 (cd at 100 feet). The correct value is 150 (cd at 100 feet) as shown in Table 1 of SAE J565b, February 1969. We incorporated this revision in the final rule.

Koito also commented that the semiautomatic headlamp beam switching device voltage regulation test procedure incorrectly refers to “dim” sensitivity in the NPRM. The correct notation is “hold” sensitivity and that is

²⁶ SAE J589, *Turn Signal Operating Units*, April 1964; SAE J910, *Vehicular Hazard Warning Signal Operating Unit*, January 1966; SAE J945, *Vehicular Hazard Warning Signal Flasher*, February 1966; SAE J590b, *Automotive Turn Signal Flashers*, October 1965; and SAE J823b, *Flasher Test Equipment*, April 1968.

what appears in paragraph S14.9.3.11.3.1.2 of the final rule.

AAM commented that the language of the semiautomatic headlamp beam switching device warmup test performance requirement of the NPRM was not faithful to SAE J565b, February 1969, Section 4.5. We have revised that language in paragraph S14.9.3.11.5.2 of the final rule to be identical to the first sentence of Section 4.5, specifically, "If the warmup time of the device exceeds 10 seconds, it must maintain the headlamps on lower beam during warmup."

Tables

Table I-a Portion of Proposed Table I

As mentioned previously, we have decided to split Table I of the NPRM into three sections. Table I-a lists lamp and reflective device requirements for passenger cars, multipurpose passenger vehicles, trucks, and buses of all widths. Where we refer to comments about the content of Table I-a, it indicates that those comments were submitted about the content of the portion of Table I of the NPRM now contained in Table I-a of the final rule.

Based on comments submitted to the docket regarding our proposal, we have decided to make several revisions to Table I-a. One of these revisions was the inclusion of the abbreviation "MPV" in parenthesis after the term "Multipurpose Passenger Vehicle" in the title of Table I-a. We have subsequently used this abbreviation several times in this document.

Guide commented that the reference in Table I for the number and color of headlamps does not directly state a number but instead makes an additional reference to Table II. We do not find this method difficult or complex, it somewhat duplicates the method of the current version of FMVSS No. 108. Sub-referencing is necessary because the number of headlamps actually used depends on the headlighting system chosen. We clarified the language of Table I-a for the number of upper beam and lower beam headlamps from " * * * type and number * * *" to " * * * headlighting system * * *" to more precisely describe this sub reference.

AAM and Koito commented about the inclusion of the phrase " * * * equal to or wider than the upper beam headlamps" in the mounting location description for lower beam headlamps along with the corresponding phrase " * * * equal to or narrower than the lower beam headlamps" in the mounting location description for the upper beam headlamps. They, along

with Honda, which commented about the same language in Table I relating to motorcycle headlamps, believe that this phrase is inconsistent with the current FMVSS No. 108 requirement. We agree that it does not fully describe the relationship required between upper and lower beam headlamps. We removed this language from Tables I-a and I-c of the final rule and incorporated headlamp beam spacing requirements in paragraph S6.1.3.5.

AAM commented that the activation requirement for turn signal lamps stating, "Current 108 paragraph S5.1.1.19 references SAE J590b * * * in which Figure 1 combines flash rate and percent current "on" time. This figure appears as Figure 2 in Rewrite 108. There is no reference to percent current "on" time in Rewrite 108 Table I. We are unable to find a reference to Rewrite Figure 108 anywhere within the Rewrite 108 text." The reference to NPRM Figure 2 is contained in Table XXI which details the performance of turn signal (and vehicular hazard warning signal) flashers, specifically in the performance requirements for the *Flash Rate and Percent Current "On" Time Test*. We agree that including the rate of 60 to 120 flashes per minute in Table I is a detail that is not needed. The flash rate will be determined by the choice of flasher and its performance when subjected to the test of paragraph S14.9.3. Therefore, we are revising the *Device Activation* requirement for turn signal lamps in Table I-a (and the corresponding requirement in Table I-b for trailers and in Table I-c for motorcycles) to read, "Flash when the turn signal flasher is actuated by the turn signal operating unit." This statement more accurately describes the process by which the turn signal lamps are caused to flash.

AAM, Honda, and Koito commented about the activation requirements for taillamps, side marker lamps, and license plate lamps with respect to their required activation when the parking lamps are activated. AAM contended that the NPRM does not clearly state that the taillamps, side marker lamps, and license plate lamps are required to be activated when the parking lamps are activated only on vehicles less than 2032 mm in overall width. To clarify those requirements, we revised the language of the activation requirement from " * * * "Must be activated when the headlamps are activated in a steady burning state or the parking lamps are activated (not a requirement for vehicles 2032 mm or more in overall width)", to " * * * "Must be activated when the headlamps are activated in a steady burning state or the parking lamps on

passenger cars and MPVs, trucks, and buses less than 80 inches in overall width are activated." This revision was made to the *Device Activation* requirements for taillamps, side marker lamps, intermediate side marker lamps, and license plate lamps in Table I-a.

AAM also commented that the activation requirement for a stop lamp optically combined with a turn signal lamp was not stated in Table I using the language from SAE J586 FEB84, at Section 5.4.2 and SAE J1398 MAY85, also at Section 5.4.2. One of the stated intentions of the rewrite is to clarify requirements without making substantive changes to them. Although we were satisfied with the language of the NPRM in this situation, we revised the language to be faithful to the original SAE language. We replaced the third sentence of the *Device Activation* requirement for stop lamps in Table I-a with "When a stop signal is optically combined with the turn signal, the circuit must be such that the stop signal cannot be turned on if the turn signal is flashing." Identical revisions have been made in Table I-b for trailers and Table I-c for motorcycles.

We have corrected an omission in Table I-a with respect to the requirements applicable to a truck tractor. The current version of FMVSS No. 108 excludes, in paragraph S5.1.1.2, a truck tractor from being required to be equipped with any rear side marker devices, rear clearance lamps, and rear identification lamps. The NPRM included this exclusion for rear side marker lamps, rear clearance lamps, and rear identification lamps but failed to include the notation for rear side reflex reflectors. This has been corrected in the final rule.

TTMA stated in its comments that the partial photometric output exclusion for clearance lamps mounted other than on the front or rear of a vehicle where necessary to indicate overall vehicle width or protect the lamps from damage, appearing in paragraph S5.3.2.1 of the current version of FMVSS No. 108, does not appear in the NPRM. The exclusion for mounting location does appear in the *Mounting Location* portion of Table I-a for both front and rear clearance lamps (and has been added to Table I-b for trailer clearance lamps). The photometric output exclusion for such lamps appears in Table XI as Footnote 4, which is the appropriate location for this detail.

TTMA also called attention to an interpretative rule issued by the agency in 1999 and published at 64 FR 16358²⁷

²⁷ 64 FR 16358, (April 5, 1999).

which quantifies the requirement that clearance lamps and identification lamps be mounted "as near the top as practicable" and describes how "practicability" will be determined for these lamps when mounted on a vehicle with cargo doors. We agree that this interpretative rule concerning presumption of practicability is important to include in FMVSS No. 108. Therefore, we have added to the *Mounting Height* portion of Table I-a, applicable to rear clearance lamps and rear identification lamps (and to those same lamps in Table I-b applicable to trailers), the sentence "Practicability of locating lamps on the vehicle header is presumed when the header extends at least 25 mm (1 inch) above the rear doors."

ASSN commented that the incorporation of the May 26, 2000 letter of interpretation to Mr. Farber²⁸ permitting stop lamps to be activated when a vehicle is slowed by a device designed to retard the motion of a vehicle, should also be extended to activation of a high-mounted stop lamp. The Farber interpretation was issued several years after high-mounted stop lamps were first required on vehicles but does not explicitly address their activation. The current version of FMVSS No. 108 contains, in paragraph S5.5.4, slightly different activation requirements for stop lamps and for high-mounted stop lamps. It states, "The stop lamps on each vehicle shall be activated upon application of the service brakes. The high-mounted stop lamp on each vehicle shall be activated *only* upon application of the service brakes" (emphasis added). This difference in activation requirements is explained in the September 10, 1990 letter of interpretation to Mr. Henneberger²⁹ which states, " * * * The second sentence of S5.5.4 restricts operation of the center stop lamp to application of the service brakes, but no such restriction exists in the first sentence. Although the first sentence requires operation of the stop lamps upon application of the service brakes, when considered in conjunction with the restriction stated in the second sentence, it can be read as implying that there may be other conditions under which activation of the stop lamps is permissible. However the reason for the difference in the two sentences is otherwise. Commonly, in red rear combination lamps, the same filament serves both the stop and turn signal functions. If the turn signal is

functioning when the brakes are applied, the first sentence ensures that the stop signal overrides the turn signal."

The Farber interpretation was incorporated into the NPRM because of its conclusion that, " * * * when a vehicle is slowed by downshifting or an engine retarder, from the perspective of the following driver, it would be equivalent to what would occur if the service brakes were applied. Therefore, it would be permissible for the stop lamps to be illuminated under this scenario, since such illumination would not create any confusion in the mind of a following driver and thus would not "impair the effectiveness" of the required stop lamps." Clearly, the Farber interpretation establishes a situation where the action of a retarder or similar device is equivalent to the action of applying the service brakes. Since S5.5.4 of the current version of FMVSS No. 108 requires activation of the high-mounted stop lamp when the service brake is applied, it follows that it may also be activated by application of a retarder. Table I-a of the final rule has been revised to include this permitted activation.

AAM recognized a typographical error in Table I-a in describing the mounting location requirements for school bus signal warning lamps. AAM suggested language that is more faithful to that of SAE J887, *School Bus Red Signal Lamps*, July 1964, the document incorporated by reference in the current version of Standard No. 108. We have revised the language of the final rule applicable to the mounting location of these lamps to state, " * * * but in no case shall the spacing between lamps be less than 40 inches", which is more faithful to SAE J887.

Nissan commented that inclusion of the Daytime Running Lamp (DRL) in a Table titled *Required Lamps and Reflective Devices* implied that the DRL was the only non-required lamp permitted on regulated vehicles. We have discussed previously that we believe Table I-a is the appropriate location for the DRL in the standard. However, we have clarified the portion of Table I-a applicable to the DRL by revising the title from "*Additional Lamps Allowed * * **" to "*Daytime Running Lamps Allowed * * **."

Nissan and AAM commented that Table I-a did not completely describe all mounting height restrictions on DRLs in the appropriate portion of the table. We have clarified in Table I-a that additional requirements do apply and are included in paragraph S7.10.13(b) of the final rule.

Guide commented that additional DRL activation requirements are contained in paragraph S7.11.2 of the NPRM and should be added to Table I-a. We disagree. There is language in Table I-a calling attention to these additional requirements and directing users to paragraph S7.10.10.1(c) of the final rule, a notice that we believe is adequate.

Table I-b Portion of Proposed Table I

In addition to those revisions to Table I-b that were listed in the preceding section, several others have been incorporated in the final rule.

AAM commented that the width criteria for installing a single taillamp, stop lamp, or rear reflex reflector on a trailer was incorrectly dimensioned. Table I-b stated that the installation of a single such device can occur " * * * on trailers less than 760 mm wide." The correct dimension from paragraph S5.1.1.14 of the current version of FMVSS No. 108 is 30 inches, and the final rule states that dimension for all three devices. Current paragraph S5.1.1.14 also states that when single devices are used, they shall be located " * * * at or near its vertical centerline." To clarify this requirement, we have revised the *Mounting Location* requirement language from "A single lamp (reflector) must be mounted at or near the vertical centerline" to "When a single lamp (reflector) is installed, it must be mounted at or near the vertical centerline."

AAM, Grote, and Koito all commented that the NPRM did not include the mounting height limitation of 60 inches for rear side marker lamps installed on trailers 2032 mm or more in overall width, which is stated in Table II of the current version of FMVSS No. 108. This omission is corrected in Table I-b in the final rule.

TTMA commented on the appropriate location for the requirement stating that conspicuity treatment on a trailer can serve as the required reflex reflectors if the conspicuity treatment is placed at the locations required for reflex reflectors. This alternative is contained in paragraph S6.1.1.1.1 in the NPRM, but we agree it is best located in Table I-b and have moved it there, following the listing of "Reflex Reflectors" and "Intermediate Reflex Reflectors", and have eliminated paragraph S6.1.1.1.1 from the final rule.

TTMA commented that the requirements for mounting height for clearance lamps and identification lamps in Table I-b was missing. We have corrected this by adding the appropriate language from Table II of the current version of FMVSS No. 108,

²⁸ <http://isearch.nhtsa.gov/files/21341.ztv.html>

²⁹ <http://isearch.nhtsa.gov/gm/90/nht90-3.93.html>

“As near the top as practicable.” We have also added language to the *Mounting Height* portion of the rear clearance lamp section stating that, similar to Table I-a, they are not required to be mounted as near the top as practicable when the rear identification lamps are mounted at the extreme height of the vehicle, an exclusion provided by paragraph S5.3.1.4 of the current version of FMVSS No. 108 and inadvertently omitted from the NPRM.

Table I-c Portion of Proposed Table I

Consistent with the revision in language to the *Number and Color* portion of headlamps in Table I-a, we have revised Table I-c. It previously stated “* * * of a type and number listed * * *,” but now states “* * * of a headlighting system listed * * *.” We believe that this revision more precisely describes this requirement.

AAM commented that there are additional motorcycle headlamp mounting restrictions that are not acknowledged in Table I-c. We agree and have added language to direct the reader to paragraphs S10.17.1.1, S10.17.1.2, and S10.17.1.3 of the final rule for additional headlamp mounting requirements.

We have inserted the language “a turn signal” between the words “between” and “lamp” in the last sentence of the *Mounting Location* portion of the front turn signal lamp requirements section of Table I-c of the final rule to clarify that requirement. Also, the language of the last sentence of the *Mounting Location* portion of the rear turn signal lamp requirements section of Table I-c was revised so that it now states, “* * * between the turn signal lamp and taillamp or stop lamp is 4 inches * * *,” a change that clarifies the requirement in the final rule.

Table II-a Headlighting Systems—Sealed Beam

GE, Honda, AAM, and Koito commented that the reference to photometry requirements in Table XIX of the NPRM for a lower beam visual aim “LF” headlamp erroneously stated “LB1⁽¹⁾” rather than “LB1V⁽¹⁾.” We agree and this has been corrected in the final rule.

Table II-b Headlighting Systems—Combination

GE, Honda, AAM, and Koito commented that the reference to photometry requirements in Table XIX of the NPRM for a 4 lamp system, lower beam visual aim headlamp erroneously stated “LBV⁽⁴⁾” rather than “LB1V⁽⁴⁾.”

We agree and this has been corrected in the final rule.

Koito commented that if an integral beam headlamp was used in a combination headlighting system, it could consist of beam contributors and if so, they would be subject to the photometric allocation formula described in paragraph S6.8.5.6.6 of the NPRM. Koito requested that a footnote be added to call attention to that possibility. We agree and have added Footnote 7 to the final rule stating “Beam contributor photometric allocation formula of paragraph S14.2.5.9 may apply.”

Table II-c Headlighting Systems—Integral Beam

Footnote 6 was revised for clarity in the final rule to read, “Beam contributor photometric allocation formula of paragraph S14.2.5.9 applies.”

Koito commented that the lower beam photometry requirements reference in the NPRM for the headlamp in a four lamp system that provides a portion of the upper beam and the lower beam should be “LB3M” rather than “LB4M” for a mechanically aimed headlamp and “LB3V” rather than “LB2V” for a visually/optically aimed headlamp. These references are taken from paragraph S7.4(a)(1)(iii) of the current version of FMVSS No. 108, which specifies Figure 28-1 or Figure 28-2. LB4M is a restatement of the requirements of Figure 28-1 and LB2V similarly of Figure 28-2.³⁰ We do not agree with Koito’s comment and are therefore making no revision in the final rule.

Table II-d Headlighting Systems—Replaceable Bulb

AAM and Koito commented that the references in Table II-d to photometry requirements in Table XIX for UB1, LB1M, and LB1V should include Footnote 4, “Lower beams may remain activated when upper beams are activated,” based upon paragraph S5.8.8 of the current version of FMVSS No. 108. We agree that the UB1, LB1M, and LB1V requirements are derived from Figures 15-1 and 15-2 of the current version of FMVSS No. 108. Paragraph S5.8.8 states that a headlighting system designed to conform to the photometric requirements of Figures 15-1 and 15-2 may be so wired. That footnote has been added to the final rule.

Koito and AAM commented that the photometric requirement reference in Table II-d of the NPRM for the upper beam of a 2 lamp system with a light

³⁰ And also Figure 17-2 which has identical requirements.

source composition of HB2 or any single filament type used alone or with any other single or dual filament type, should include UB3 (Figure 27-1 or 27-2 in the current version of FMVSS No. 108) as well as the listed UB2 (Figure 17-1 or 17-2 in the current version of FMVSS No. 108). They provide the rationale that this is permitted by paragraph S7.5(d)(2)(ii)(A)(1) of the current version of FMVSS No. 108. Indeed, a literal reading of that text could lead to such a conclusion. However, Figure 26, *Table for Determining the Photometric Requirements of Replaceable Bulb Headlamp Systems*, of the current version of FMVSS No. 108 clearly shows, in the box where the row marked “Two-Headlamp System” intersects the column marked “HB2 or Any Single Filament Type used Alone or with Any Other Single or Dual Filament Type,” that the applicable photometry requirements are those of Figure 17-1 or 17-2.³¹ Faced with the seeming contradiction between paragraph S7.5(d)(2)(ii)(A)(1) and Figure 26, we looked for other cues in FMVSS No. 108 that would confirm the correct requirement. One such cue is in paragraph S7.5(b) which states that, “The photometrics as specified in subparagraphs (c) through (e) of this paragraph (depicted in Figure 26), using any light source of the Type intended for use in such system.” This clearly indicates that paragraph S7.5 and Figure 26 provide identical information. Another cue is the language in paragraph S7.5(d)(2)(i)(A)(2) which states that only the photometry requirements of Figure 17-1 or 17-2 are to be used for lower beam with a two lamp system that uses an HB2 source.

The specific language of paragraph S7.5(d)(2)(ii)(A)(1) first appeared in Standard No. 108 several years ago during a revision in text. Instead of concluding with “* * * light sources that include Type HB2 * * *” paragraph S7.5(d)(2)(ii)(A)(1) should have concluded with “* * * light sources other than Type HB2 * * *” This would make it consistent with paragraph S7.5(d)(2)(i)(A)(1), which addresses the lower beam, and Figure 26.

Because this ambiguity has existed for a considerable length of time, it would be a substantive change to revise it in the final rule and thus is outside the scope of the rewrite. We have revised

³¹ The current version of FMVSS 108 presents headlamp photometry requirements in sets of related tables that differ only by application to type of aiming system used. In this instance Table 17-1 applies to mechanically aimed headlighting systems while Table 17-2 applies to visually/optically aimed headlighting systems.

Table II–d in the final rule to indicate that UB3 may be used as an upper beam photometry requirement for a 2 lamp system using a Type HB2 or any single filament type used alone, or with any other single or dual filament type. However, regulated parties should be aware that we consider this to be incorrect and we may take action soon to correct what we believe is a mistake.

Table III Conspicuity Systems Requirements Becomes Table III Marking Requirements Location

The recognition that the tabular method of organization did not work well for the presentation of lengthy textual requirements provided the rationale for moving the conspicuity systems requirements content of Table III of the NPRM to paragraph S8.2 of the regulatory text of the final rule. The substantive issues raised by public comment and the revisions to conspicuity systems are discussed under paragraph S8.2. As discussed under paragraph S6.5, Table III has been re-designated as a source for listing each location in the regulatory text of the final rule applicable for each marking requirement of Standard No. 108.

Table IV Effective Projected Luminous Lens Area Requirements

As previously mentioned, this table has been divided into three sections in the final rule.

Koito and Guide commented that the effective projected luminous lens area requirements for a front turn signal lamp were incorrectly stated in what is now Table IV–a and did not agree with the requirements of SAE J588 NOV84. We concur and have clarified those requirements in the final rule to indicate that there is no effective projected luminous lens area requirement for each compartment of a multiple compartment front turn signal lamp.

There were no comments submitted that impacted what are now Tables IV–b and IV–c in the final rule.

Table V Visibility Requirements of Installed Lighting Devices

As previously mentioned, this table has been divided into four sections. AAM suggested that the column marked “Applicable Vehicles” was not needed. We agree and have removed it from all four sections of Table V in the final rule.

Table V–a Visibility Requirements of Installed Lighting Devices

AAM suggested alternative language referring to the required visibility of high-mounted stop lamps when two lamps are installed. We agree with its suggestion and have revised the

language of the final rule appearing in parenthesis to read (Single lamp or two lamps together where required by paragraph S6.1.1.2 of this standard.)

Table V–b Visibility Requirements of Installed Lighting Devices (Lens Area Visibility Option)

Grote suggested that the mandatory enforcement dates for the exclusive use of the visibility options of Table V–b and V–c be included in those tables. We believe it is preferable to include these dates in paragraph S6.4.4 of the regulatory text of the final rule, where additional details about choosing a visibility compliance method are located.

AAM suggested that the language of Footnote 2 of Table V–b (and Footnote 2 of Table V–c) be revised for clarity.

We agree and those footnotes now read in the final rule, “Where a lamp is mounted with its axis of reference less than 750 mm above the road surface, the vertical test point angles located below the horizontal plane subject to visibility requirements may be reduced to 5° down.”

Table V–c Visibility Requirements of Installed Lighting Devices (Luminous Intensity Visibility Option)

AAM claimed that the visibility requirements specifying corner points at 80° outboard are erroneous. We disagree because these corner points are faithful to those stated in Figure 20 of the current version of FMVSS No. 108.

Table V–d Visibility Requirements of Installed Lighting Devices (Legacy Visibility Alternative)

AAM identified a typographical error in the proposal where a period did not directly follow the abbreviation “mm” in the required visibility of turn signal lamps. This has been corrected in the final rule by removing all periods after these abbreviations in keeping with the style of regulatory text.

Nissan believed that the term “existing” in the parenthetical subtitle of this section was indeterminate and suggested it be removed. We decided to revise the subtitle from “(Existing SAE Visibility Alternative)” to “(Legacy Visibility Alternative)” in the final rule suggesting that these requirements are ones that have historically been used.

Guide commented that the sentence “Where more than one lamp or optical area is lighted on each side of the vehicle, only one such area on each side need comply” should not be included in visibility requirements. We disagree because it is an integral part of the SAE

documents incorporated by reference in the current version of FMVSS No. 108.³²

Guide also suggested that the phrase “To be considered visible” preface the specific visibility requirements in Table V–d. We believe that the language of the requirements in Table V–d, along with the text of paragraph S6.4.4, clearly describe what is required and the additional language is not needed.

We have revised the visibility requirement minimum value for a taillamp in Table V–d from 1250 sq mm to 2 sq in to be faithful to the language of SAE J585e, September 1977, Section 4, incorporated by reference in the current version of FMVSS No. 108, which is the original source of this requirement.

Table VI Front Turn Signal Lamp Photometry Requirements

As previously mentioned, this table has been divided into two sections. Table VI–a contains the base front turn signal lamp photometry requirements and the 2.5 times base front turn signal lamp photometry requirements. Table VI–b contains the 1.5 times base and the 2.0 times base front turn signal lamp photometry requirements.

Nissan, AAM, and Koito commented that displaying the ratio requirements for both turn signal lamps combined with parking lamps and turn signal lamps combined with clearance lamps in the same column of our proposal was confusing. We agree and have placed the requirements for those two combinations in separate columns in both Tables VI–a and VI–b in the final rule.

Koito and AAM commented that Footnote 4 does not accurately state the requirements of SAE J1395 AP85, Section 5.1.5.2, incorporated by reference in the current version of FMVSS No. 108. We agree and have revised that footnote in the final rule to read “When a clearance lamp on a vehicle 2032 mm or more in overall width is combined with a front turn signal lamp and the maximum luminous intensity of the clearance lamp is located below horizontal and within a 1.0° radius around the test point, the ratio for the test point may be computed by using the lowest value of the clearance lamp luminous intensity within the generated area.”

AAM noted several instances where the group minimum photometric intensity values for 2 and 3 lighted sections, 2.5x base photometry lamps, were erroneous. These five values were

³²SAE J1395 APR85, S5.4.1, SAE J586 FEB84, S5.4.1, SAE J1398 MAY85, S5.4.1, and SAE J585e, September 1977, S4.

all 0.5 cd less than their calculated values. The correct values have been incorporated in Table VI-a in the final rule.

Koito suggested that several of the group minimum photometric intensity values for 2 lighted sections, base photometry lamps, are erroneous. Koito appears to have based its comment on the observation that the arithmetic sum of the minimum values of all test points included in the groups exceeds the value shown for the group. However, in this case all of the listed values are accurate. They are consistent with values of Table 1 for group requirements and Table 3 for individual test point requirements of SAE J588 NOV84, incorporated by reference in the current version of Standard No. 108. Although in most cases SAE has specified that group photometric values equal the sum of the individual test point values in a group, there are exceptions, and this is one of those exceptions.

Table VII Rear Turn Signal Photometry Requirements

Footnote 6 of the final rule was revised to agree with the decision to eliminate the reference to SAE J588e for double faced turn signal lamps installed on truck tractors. It now reads, "A double-faced turn signal lamp installed as described in paragraph S6.1.1.3 on a truck tractor need only meet the photometric requirements for a left side lamp where the lamp is mounted on the left side of the vehicle, and for a right side lamp where the lamp is mounted on the right side of the vehicle."

Table VIII Taillamp Photometry Requirements

Calcoast commented that Footnote 1 and Footnote 2 to Table VIII of the NPRM are not mutually exclusive. Therefore, the limitations imposed by compliance with one of these footnotes may negate an allowance offered by the other. We agree with Calcoast's assessment. The situation that it mentioned actually affects all lamps where grouped test point photometric compliance is permitted. The requirements of Footnote 1 of Table VIII also apply to all other lamps where grouped compliance is permitted. The original source of this requirement is SAE J575, *Test for Motor Vehicle Lighting Devices and Components*, paragraph J, which is identical in both J575d, August 1967, and J575e, August 1970, the two versions of this standard applicable to signal lamps in FMVSS No. 108. Footnote 2 of Table VIII describes the basic premise of grouped compliance. The failure of an individual test point in the group to meet its

minimum photometric intensity can be offset if one or more of the other points in the group exceed their minimum intensity requirement by enough margin that the group total intensity is still met.

Additionally, turn signal lamps and stop lamps, including high-mounted stop lamps, also have a further limitation from their original SAE source document concerning how much any individual test point can fail to meet its minimum intensity when considered in a group compliance situation. This limitation states that the measured value at each test point must not be less than 60% of the minimum value.

All these limitations must be considered simultaneously when determining grouped photometric compliance for lamps where that procedure is permitted. Calcoast was correct in its assessment that these limitations may negate full utilization of each other.

Koito and AAM identified two minimum test point photometric intensity values for 3 lighted section lamps they believe are erroneous. We agree and have corrected the values at 5L-10D and 5R-10D in the final rule.

We have also revised Table VIII in the final rule to reduce confusion by placing the minimum and maximum photometric intensity values in separate columns for each of the lighted sections alternatives.

Koito commented that Table VIII did not include Footnote 5 from Table 1 of SAE J585e, *Tail Lamps (Rear Position Lamps)*, September 1977, incorporated by reference in the current version of FMVSS No. 108. This footnote limits the size of the area of maximum photometric intensity in a specified portion of the photometric pattern. This requirement was added to Table VIII in the final rule and now reads, "A taillamp shall not exceed the maximum intensity over any area larger than that generated by a 0.25° radius, within a solid cone angle from 20°L to 20°R and from H to 10°U."

Table IX Stop Lamp Photometry Requirements

The alternative photometric intensity requirements for a stop lamp installed on a motor driven cycle that were included in Table IX in the NPRM have been relocated to new Table XIII in the final rule. This relocation means that Footnote 5 is no longer needed in Table IX and it has been eliminated. Footnote 7 of the NPRM has been redesignated as Footnote 5 in the final rule.

Honda, AAM, and Koito all observed an erroneous group minimum photometric intensity value for 3 lighted

sections in group 3. The correct value is 520 cd instead of the listed 445 cd. This error is corrected in Table IX of the final rule.

In Table IX of the NPRM, it was stated that when a stop lamp is combined with a taillamp, the luminous intensity of the stop signal must exceed the luminous intensity of the tail signal at each test point by a certain minimum ratio. This ratio value is common for all vehicles at all test points with the exception of the test point H-5L.³³ Proposed Table IX showed the ratio value at this point as 3/5⁽⁶⁾ and further states at Footnote 6, "Values preceded by a slash (/) apply only to lamps installed on multipurpose passenger vehicles, trucks, trailers, and buses, of 2032 mm or more in overall width." Thus, the requirement at the H-5L test point is that the luminous intensity of the stop lamp exceed the luminous intensity of the combined taillamp by at least 3 times on multipurpose passenger vehicles, trucks, trailers, and buses, of 2032 mm or more in overall width, and by at least 5 times on other applicable vehicles which includes all passenger cars and motorcycles and all multipurpose passenger vehicles, trucks, trailers, and buses, less than 2032 mm in overall width. This discrepancy exists due to the language from which the ratio requirements are derived. SAE J586 FEB84, *Stop Lamps for use on Motor Vehicles Less Than 2032 mm in Overall Width*, incorporated by reference in the current version of FMVSS No. 108 states in Section 5.1.5.3, "When a tail lamp is combined with the stop lamp, the stop lamp shall not be less than three times the luminous intensity of the tail lamp at any test point; except that at H-V, H-5L, H-5R, and 5U-V, the stop lamp shall not be less than five times the luminous intensity of the tail lamp." Similarly, SAE J1398 MAY85, *Stop Lamps for use on Motor Vehicles 2032 mm or More in Overall Width*, incorporated by reference in the current version of FMVSS No. 108, states in Section 5.1.5.2, "When a tail lamp is combined with the stop lamp, the stop lamp shall not be less than three times the luminous intensity of the tail lamp at any test point; except that at H-V, H-5R, and 5U-V, the stop lamp shall not be less than five times the luminous intensity of the tail lamp." Thus, the requirements are identical with the exception of test point

³³ In the final rule we have elected to implement a suggestion by Calcoast to identify photometric test points consistently in the photometric requirements tables. We have chosen to list lateral values in the left column and vertical values in the right column. Thus the H-5L test point of Table IX of the NPRM appears as test point 5L-H in the final rule.

H-5L. By not specifically identifying H-5L as a test point requiring a 5:1 ratio, SAE J1398 MAY85, by default, requires a 3:1 ratio.

SAE J585e, *Tail Lamps (Rear Position Lamps)*, September 1977, also incorporated by reference in the current version of FMVSS No. 108 (applicable to all vehicles), also contains a ratio requirement. Footnote 4 to Table 1 of that document states, "When a tail lamp is combined with the turn signal lamp or the stop lamp, the signal lamp or stop lamp shall not be less than three times the candlepower³⁴ of the tail lamp at any test point; except that at H-V, H-5L, H-5R, and 5U-V, the signal lamp or stop lamp shall not be less than five times the candlepower of the tail lamp." Thus, there is a documented conflict regarding the ratio requirement at the H-5L test point on combined stop lamps and taillamps used on wide vehicles. We resolved this in the final rule by maintaining the dual requirements stated in the NPRM. That is the ratio of stop lamp intensity to taillamp intensity at that test point remains 3:1 for lamps installed on multipurpose passenger vehicles, trucks, trailers, and buses, of 2032 mm or more in overall width, and 5:1 for lamps installed on all passenger cars and motorcycles and all multipurpose passenger vehicles, trucks, trailers, and buses, less than 2032 mm in overall width.

Although we believe there is ample evidence that the 3:1 ratio was never intended by SAE, to rectify this error at this time would constitute a substantive change and therefore be beyond the scope of the FMVSS No. 108 rewrite. We may address this issue in the near future.

Table X Side Marker Photometry Requirements

Footnote 1 was revised to be more consistent with paragraph S7.4.1.1 of the NPRM (paragraph S7.4.13.2 of the final rule) concerning the widths of vehicles that can use reduced photometric compliance angles between the front and rear side marker. Footnote 1 now reads, "Where a side marker lamp installed on a motor vehicle less than 30 feet in overall length and less than 80 inches (2 m) in overall width has the lateral angle nearest the other required side marker lamp on the same side of the vehicle reduced from 45° by design as specified by S7.4.13.2, the photometric intensity measurement may be met at the lesser angle." The change in width from 2032 mm to 80 inches (2

m) was made to be faithful to Footnote b of SAE J592e, *Clearance, Side Marker, and Identification Lamps*, July 1972.

Table XI Clearance and Identification Lamps Photometry Requirements

Koito and AAM commented that Footnote 3 to Table XI did not include the limitation on a turn signal lamp combined with a red clearance lamp as required by SAE J592e, July 1972, Table 1 Footnote "a", incorporated by reference by the current version of FMVSS No. 108. This is corrected in the final rule.

Grote believed that the maximum photometric intensity for a red clearance lamp should be 18 cd. We disagree because SAE J592e, July 1972, incorporated by reference in the current version of FMVSS No. 108, states in Footnote "a" to Table 1 that 15 cd is the maximum allowed for a red clearance lamp.

Table XII Backup Lamp Photometry Requirements

Guide commented that Footnotes 2 and 3 only apply to groups 1, 2, 5, and 6. We agree. Figure 2, Footnote 1 of the current version of Standard No. 108 is the source of these requirements and the Guide assertion is consistent with that figure. We revised Table XII accordingly in the final rule.

Guide suggested replacing the phrase "same or symmetrically opposite design" in Footnote 2 of Table XII of the NPRM with the phrase "symmetrical beam pattern" and also replacing the phrase "differing design" in Footnote 3 of Table XII with the phrase "asymmetrical beam pattern", claiming the terminology of the NPRM is vague. Guide offered no argument as to why the suggested replacement phrases would improve understanding. Since the language of the NPRM is faithful to the current version of FMVSS No. 108, we are not implementing its suggestion in the final rule.

We have added the term "Each Lamp" after the title "Two Lamp Systems" in Table XII of the final rule to clarify that each lamp of a two lamp system is to be designed to conform to either the individual test point photometry requirements or the group photometry requirements.

Table XIII-a Motorcycle Turn Signal Lamp Alternative Photometry Requirements

Table XIII-b Motor Driven Cycle Stop Lamp Alternative Photometry Requirements

Table XIII of the NPRM, License Plate Lamp Target Locations, has been redesignated as Figure 19 in the final

rule. A new Table XIII has been created that includes the alternative stop lamp requirements for motor driven cycles, which were previously part of Table IX in the NPRM and the optional turn signal requirements for motorcycles noted in paragraphs S7.1.1.1 and S7.1.2.1 of the NPRM, but not previously tabularized.

Table XIV Parking Lamp Photometry Requirements

There were no comments submitted that impacted Table XIV beyond those previously mentioned.

Table XV High-Mounted Stop Lamp Photometry Requirements

AAM suggested that Footnote 4 of Table XV be incorporated directly into the table where the maximum photometric intensity is stated. AAM offered no arguments to support this request and we can see no compelling reason to implement it. Table XV appears in the final rule identical to the NPRM.

Table XVI

As previously mentioned, Table XVI of the NPRM has been partitioned into three sections, Table XVI-a, *Reflex Reflector Photometry Requirements*, Table XVI-b, *Additional Photometry Requirements for Conspicuity Reflex Reflectors*, and Table XVI-c, *Retroreflective Sheeting Photometry Requirements*. The content of these tables in the final rule is identical to that of the NPRM.

Table XVII School Bus Signal Lamp Photometry

There were no comments submitted that impacted Table XVII.

Table XVIII Headlamp Upper Beam Photometry Requirements

There were no comments submitted that impacted Table XVIII beyond those previously mentioned.

Table XIX Headlamp Lower Beam Photometry Requirements

Table XIX, *Headlamp Lower Beam Photometry Requirements*, has been split into Tables XIX-a, XIX-b, and XIX-c in the final rule.

GE, Honda, AAM, and Koito identified that the maximum photometric intensity value of 2,500 cd for the 0.5D-1.5L to L test location of a LB4M beam was inadvertently omitted from Table XIX of the NPRM. We agree and this value has been added in the final rule.

Guide suggested a reduction in the lateral limits in the NPRM for photometry of the 10°U to 90°U glare

³⁴ The term "candlepower" used in this context means the contemporary unit of measurement used to express the luminous intensity attribute.

area from 90°L to 90°R to 45°L to 45°R but offered no basis to support this request. Such a revision would be substantive and beyond the scope of the rewrite, therefore this suggestion was not pursued in the final rule.

Table XX Motorcycle and Motor Driven Cycle Headlamp Photometry Requirements

Honda and Koito identified that the maximum photometric intensity value of 12,500 cd for the 4D-4R test location for a motor driven cycle headlamp was inadvertently placed in the minimum intensity column of Table XX of the NPRM. The value has been placed in the correct location in the final rule.

AAM suggested that the column heading shown for lower beam headlamps be replicated for upper beam headlamps. We agree that doing so would improve clarity and have incorporated the headings in Table XX of the final rule.

Table XXI Associated Equipment Physical Test Requirements (Table eliminated in final rule)

The recognition that the tabular method of organization did not work well for lengthy textual requirements provided the rationale for moving the associated equipment physical test requirements content of Table XXI of the NPRM to paragraph S14.9 of the regulatory text in the final rule.

The substantive issues raised by public comment and the revisions to associated equipment physical test requirements are discussed under paragraph S14.9.

Table XXII Lamp and Reflective Devices Physical Test Requirements (Table eliminated in final rule)

The recognition that the tabular method of organization did not work well for lengthy textual requirements provided the rationale for moving the lamp and reflective devices physical test requirements content of Table XXII of the NPRM to paragraphs S14.3, S14.4, and S14.5 of the regulatory text in the final rule.

The substantive issues raised by public comment and the revisions to lamp and reflective devices physical test requirements are discussed under those sections.

Table XXIII Headlamp Physical Test Requirements (Table eliminated in final rule)

The recognition that the tabular method of organization did not work well for lengthy textual requirements provided the rationale for moving the headlamp physical test requirements content of Table XXIII of the NPRM to

paragraphs S14.6, S14.7, and S14.8 of the regulatory text in the final rule.

The substantive issues raised by public comment and the revisions to headlamp physical test requirements are discussed under those sections.

Figures

Figures 1 through 12 and 15 through 18

There were no comments submitted that impacted Figures 1 through 12 or Figures 15 through 18.

Figure 13 Tractor Conspicuity Treatment Examples

TMA commented that Figure 31 of the current version of FMVSS No. 108, rather than Figure 13 of the NPRM, better illustrated that the right angle white conspicuity treatment element required on the upper rear outside corners of truck tractors may not be continuous if cab mounted hardware makes this impractical. We have revised Figure 13 to illustrate this condition in the final rule.

Figure 14 92 x 150 mm Headlamp Aim Deflection Test Setup

GE identified 13 omissions or errors in Figure 14 of the NPRM that were corrected in the final rule to agree with the source document, Figure 16 of the current version of FMVSS No. 108.

Figure 15 Types G & H Headlamp Aim Deflection Test Setup

GE identified an omission in Figure 15 that was corrected to agree with the source document, Figure 22 of the current version of FMVSS No. 108.

Figure 19 License Plate Lamp Target Locations

Figure 19, *License Plate Lamp Target Locations*, was designated as Table XIII in the NPRM. The supplementary response from the AAM/ASSN suggested changing it to be a figure. Its purpose is illustrative, so it is most appropriately designated as a figure.

AAM requested that the English units of measurement, which were part of the source drawings, SAE J587 OCT81 Figures 1 and 2, but not included in Table XIII of the NPRM, be restored. This was done, as Figure 19 is dimensioned in both metric and English units in the final rule.

Figure 20 License Plate Lamp Measurement of Incident Light Angle

AAM requested that Figure 3 of SAE J587 OCT81, *License Plate Lamps*, be included to better illustrate the incident light angle requirement of paragraph S7.7.1.1 of the NPRM. We agree and have included it as Figure 20, *License Plate Lamp Measurement of Incident*

Light Angle, in the final rule. It is referenced in paragraph S7.7.15.4 of the final rule.

Figure 21 Vibration Test Machine

AAM requested that SAE J577, *Vibration Test Machine*, April 1964, be directly incorporated into FMVSS No. 108 rather than to continue to be incorporated by reference. Figure 1, *Vibration Test Machine*, and Table 1, *Cam Profile Radii*, (from SAE J577) were redrawn for the final rule as Figure 21, *Vibration Test Machine*.

Figure 22 Flasher Standard Test Circuit

Figure 22 includes the standard test circuit of SAE J823b, *Flasher Test Equipment*, April 1968. The procedures of SAE J823b have also been incorporated into paragraph S14.9 of the final rule, allowing the subreference by incorporation of this standard to now be eliminated from FMVSS No. 108.

IV. The Final Rule

After careful consideration of public comments on the NPRM, the agency has decided to publish a final rule to amend 49 CFR Part 564 and FMVSS No. 108 as discussed below:

A. 49 CFR Part 564

We are relocating figures addressing sealed beam headlamps that currently reside in FMVSS No. 108 and SAE J1383 APR85 into a newly created Appendix C of 49 CFR Part 564. We have listed those specific figures and where they currently reside in FMVSS No. 108 or SAE J1383 APR85 in the reference document in Appendix C of this notice. In addition, we are making the applicable changes to the scope and purpose provisions of Part 564 to account for the newly formed Appendix C. Unlike Appendices A and B, there will be no further additions to, or modifications of, the sealed beam headlamp figures in Appendix C.

B. 49 CFR Part 571.108

We are amending Standard No. 108 by: (1) Reorganizing the regulatory text so that it provides a more straightforward and logical presentation of the applicable regulatory requirements; (2) including important agency interpretations of the existing requirements; and (3) reducing reliance on third-party documents incorporated by reference. This has resulted in additional tables and figures being added to the standard. In addition, the structure of the standard has been changed to present the requirements in a more standardized and user-friendly manner.

V. Benefits and Costs

Because this proposal only reorganizes the existing requirements of the standard, we do not anticipate that there would be any costs or benefits associated with this rulemaking action to implement an administrative rewrite of FMVSS No. 108, other than the benefits associated with a clearer, easier-to-read standard. None of the public comments identified any instances where the rewritten standard would have a cost effect. Accordingly, the agency did not conduct a separate economic analysis for this rulemaking.

VI. Rulemaking Analyses and Notices

A. Vehicle Safety Act

Under 49 U.S.C. Chapter 301, *Motor Vehicle Safety* (49 U.S.C. 30101 *et seq.*), the Secretary of Transportation is responsible for prescribing motor vehicle safety standards that are practicable, meet the need for motor vehicle safety, and are stated in objective terms.³⁵ These motor vehicle safety standards set the minimum level of performance for a motor vehicle or motor vehicle equipment to be considered safe.³⁶ When prescribing such standards, the Secretary must consider all relevant, available motor vehicle safety information.³⁷ The Secretary must also consider whether a proposed standard is reasonable, practicable, and appropriate for the type of motor vehicle or motor vehicle equipment for which it is prescribed and the extent to which the standard will further the statutory purpose of reducing traffic accidents and associated deaths.³⁸ The responsibility for promulgation of Federal motor vehicle safety standards has been delegated to NHTSA.³⁹

FMVSS No. 108, *Lamps, Reflective Devices, and Associated Equipment*, was originally established in a final rule published in the **Federal Register** on February 3, 1967 (32 FR 2408). The purpose of the standard is to reduce traffic accidents and deaths and injuries resulting from traffic accidents, by providing adequate illumination of the roadway, and by enhancing the conspicuity of motor vehicles on the public roads so that their presence is perceived and their signals understood, both in daylight and in darkness or other conditions of reduced visibility. Since the time of the standard's initial promulgation, the agency has

undertaken numerous rulemakings and interpretations related to Standard No. 108, in many cases to deal with the emergence of new lighting technologies. In recent years, concerns have been raised that after nearly four decades of amendment, navigating the requirements of the standard has become increasingly difficult. Therefore, in this final rule, the agency is implementing an administrative rewrite of Standard No. 108 in order to improve its structure and clarity, without changing any of its existing substantive requirements. In preparing this final rule, the agency carefully considered the statutory requirements of 49 U.S.C. Chapter 301.

First, this final rule reflects the agency's careful consideration and analysis of all existing regulatory provisions of FMVSS No. 108, as well as salient letters of interpretation related to that standard. In developing the substantive provisions of the standard over the years, the agency considered all relevant, available motor vehicle safety information, including available research, testing results, and other information related to various technologies. This administrative rewrite does not change any of these existing provisions or the underlying basis therefore. The final rule also reflects the agency's consideration of information offered in public comments on the notice of proposed rulemaking which preceded today's final rule.

Second, to ensure that the requirements of FMVSS No. 108 are practicable (as well as consistent with our safety objectives), the agency evaluated the cost, availability, and suitability of the standard's provisions, both when initially adopted and during subsequent amendments. As noted above, the changes resulting from this final rule are administrative in nature and would not impact the costs and benefits of the standard. In sum, we believe that this final rule is practicable, and we expect it to maintain the benefits of Standard No. 108.

Third, the regulatory text following this preamble is stated in objective terms in order to specify precisely what performance is required and how performance will be tested to ensure compliance with the standard. In certain cases, the final rule modifies the language of the standard to improve clarity or to incorporate existing interpretations, again without changing the substance of the existing requirements.

Fourth, we believe that this final rule meets the need for motor vehicle safety by clarifying the safety standard, thereby making it easier for regulated

parties to comply with all applicable requirements. The impacts of the substantive provisions on vehicle safety were discussed at the time of adoption of those provisions.

Finally, we believe that this final rule is reasonable and appropriate for motor vehicles subject to the applicable requirements. As discussed elsewhere in this notice, the modifications to the standard resulting from this final rule are administrative in nature. It does not affect the substance of the requirements or the bases for those requirements, as articulated in earlier rulemakings. Accordingly, we believe that this final rule is appropriate for covered vehicles that are or become subject to these provisions of FMVSS No. 108 because it furthers the agency's objective of preventing crash-related deaths and serious injuries by ensuring adequate illumination of roadways and enhanced conspicuity of motor vehicles.

B. Executive Order 12866 and DOT Regulatory Policies and Procedures

Executive Order 12866, "Regulatory Planning and Review", provides for making determinations whether a regulatory action is "significant" and therefore subject to OMB review and to the requirements of the Executive Order. The Order defines a "significant regulatory action" as one that is likely to result in a rule that may:

- (1) Have an annual effect on the economy of \$100 million or more or adversely affect in a material way the economy, a sector of the economy, productivity, competition, jobs, the environment, public health or safety, or State, local, or Tribal governments or communities;
- (2) Create a serious inconsistency or otherwise interfere with an action taken or planned by another agency;
- (3) Materially alter the budgetary impact of entitlements, grants, user fees, or loan programs or the rights and obligations of recipients thereof; or
- (4) Raise novel legal or policy issues arising out of legal mandates, the President's priorities, or the principles set forth in the Executive Order.

This rulemaking document was not reviewed by the Office of Management and Budget under Executive Order 12866. The rule is not considered to be significant within the meaning of E.O. 12866 or the Department of Transportation's Regulatory Policies and Procedures (44 FR 11034 (Feb. 26, 1979)). As stated above in Section V, *Benefits and Costs*, this final rule is not expected to require parties subject to the requirements of the safety standard to alter their existing practices for certifying compliance with Standard

³⁵ 49 U.S.C. 30111(a).

³⁶ 49 U.S.C. 30102(a)(9).

³⁷ 49 U.S.C. 30111(b).

³⁸ *Id.*

³⁹ 49 U.S.C. 105 and 322; delegation of authority at 49 CFR 1.50.

No. 108 or to increase costs of compliance, because the final rule merely reorganizes and clarifies existing requirements. Accordingly, the agency has not prepared any supplemental economic analysis to accompany this rulemaking document.

C. Regulatory Flexibility Act

Pursuant to the Regulatory Flexibility Act (5 U.S.C. 601 *et seq.*, as amended by the Small Business Regulatory Enforcement Fairness Act (SBREFA) of 1996), whenever an agency is required to publish a notice of rulemaking for any proposed or final rule, it must prepare and make available for public comment a regulatory flexibility analysis that describes the effect of the rule on small entities (*i.e.*, small businesses, small organizations, and small governmental jurisdictions). The Small Business Administration's regulations at 13 CFR Part 121 define a small business, in part, as a business entity "which operates primarily within the United States." (13 CFR 121.105(a)). No regulatory flexibility analysis is required if the head of an agency certifies the rule will not have a significant economic impact on a substantial number of small entities. SBREFA amended the Regulatory Flexibility Act to require Federal agencies to provide a statement of the factual basis for certifying that a rule will not have a significant economic impact on a substantial number of small entities.

NHTSA has considered the effects of this final rule under the Regulatory Flexibility Act. I certify that this final rule will not have a significant economic impact on a substantial number of small entities. The rationale for this certification is that the present final rule does not make any substantive changes to this safety standard, so affected parties will be able to continue current practices without change. Accordingly, we do not anticipate that this final rule will have a significant economic impact on a substantial number of small entities.

D. Executive Order 13132 (Federalism)

NHTSA has examined today's final rule pursuant to Executive Order 13132, "Federalism" and concluded that no additional consultation with States, local governments, or their representatives is mandated beyond the rulemaking process. The agency has concluded that the rule does not have Federalism implications, because the rule does not have "substantial direct effects on the States, on the relationship between the national government and the States, or on the distribution of

power and the responsibilities among the various levels of government."

Further, no consultation is needed to discuss the preemptive effect of today's rule. NHTSA rules can have preemptive effect in at least two ways. First, the National Traffic and Motor Vehicle Safety Act contains an express preemptive provision: "When a motor vehicle safety standard is in effect under this chapter, a State or a political subdivision of a State may prescribe or continue in effect a standard applicable to the same aspect of performance of a motor vehicle or motor vehicle equipment only if the standard is identical to the standard prescribed under this chapter." 49 U.S.C. 30102(b)(1).

In addition to the express preemption noted above, the Supreme Court has also recognized that State requirements imposed on motor vehicle manufacturers, including sanctions imposed by State tort law, can stand as an obstacle to the accomplishment and execution of a NHTSA safety standard. When such a conflict is discerned, the Supremacy Clause of the Constitution makes the State requirements unenforceable. *See Geier v. American Honda Motor Co.*, 529 U.S. 861 (2000).

NHTSA does not believe that such conflicts are likely to arise from today's rulemaking, because this final rule only results in an administrative rewrite of the existing requirements of FMVSS No. 108. However, if such a conflict were to become evident, NHTSA may opine on such conflicts in the future, if warranted. *See id.* at 883–86.

E. Executive Order 12988 (Civil Justice Reform)

With respect to the review of the promulgation of a new regulation, section 3(b) of Executive Order 12988, "Civil Justice Reform," requires that Executive agencies make every reasonable effort to ensure that the regulation: (1) Clearly specifies the preemptive effect; (2) clearly specifies the effect on existing Federal law or regulation; (3) provides a clear legal standard for affected conduct, while promoting simplification and burden reduction; (4) clearly specifies the retroactive effect, if any; (5) adequately defines key terms; and (6) addresses other important issues affecting clarity and general draftsmanship under guidelines issued by the Attorney General. This document is consistent with that requirement. Pursuant to this Order, NHTSA notes as follows. The preemptive effect of this rule is discussed above. NHTSA notes further that there is no requirement that individuals submit a petition for

reconsideration or pursue other administrative proceeding before filing suit in court.

F. Executive Order 13045 (Protection of Children From Environmental Health and Safety Risks)

Executive Order 13045, "Protection of Children from Environmental Health and Safety Risks," applies to any rule that: (1) Is determined to be "economically significant" as defined under Executive Order 12866, and (2) concerns an environmental, health, or safety risk that the agency has reason to believe may have a disproportionate effect on children. If the regulatory action meets both criteria, the agency must evaluate the environmental health or safety effects of the planned rule on children, and explain why the planned regulation is preferable to other potentially effective and reasonably feasible alternatives considered by the agency.

This final rule is not subject to E.O. 13045 because it is not an economically significant regulatory action under Executive Order 12866, and because it does not involve decisions based upon health and safety risks that disproportionately affect children.

G. Paperwork Reduction Act

Under the Paperwork Reduction Act of 1995 (PRA), a person is not required to respond to a collection of information by a Federal agency unless the collection displays a valid OMB control number. This final rule does not contain any collection of information requirements requiring review under the PRA.

H. National Technology Transfer and Advancement Act

Section 12(d) of the National Technology Transfer and Advancement Act of 1995 (NTTAA), Public Law 104–113, (15 U.S.C. 272) directs the agency to evaluate and use voluntary consensus standards in its regulatory activities unless doing so would be inconsistent with applicable law or is otherwise impractical. Voluntary consensus standards are technical standards (*e.g.*, materials specifications, test methods, sampling procedures, and business practices) that are developed or adopted by voluntary consensus standards bodies, such as the Society of Automotive Engineers. The NTTAA directs us to provide Congress (through OMB) with explanations when we decide not to use available and applicable voluntary consensus standards. The NTTAA does not apply to symbols.

This final rule does not adopt or reference any new industry or consensus standards that were not already present in Standard No. 108 (although in several cases, relevant requirements from such standards are now included directly in the standard, rather than being incorporated by reference). The agency's statements regarding the rationale for the use (or non-use) of information from third-party standards, as presented in prior rulemakings, remain unchanged.

I. Unfunded Mandates Reform Act

Section 202 of the Unfunded Mandates Reform Act of 1995 (UMRA) requires Federal agencies to prepare a written assessment of the costs, benefits, and other effects of proposed or final rules that include a Federal mandate likely to result in the expenditure by State, local, or tribal governments, in the aggregate, or by the private sector, of more than \$100 million annually (adjusted for inflation with base year of 1995 (so currently \$126 million in 2006 dollars)). Before promulgating a NHTSA rule for which a written statement is needed, section 205 of the UMRA generally requires the agency to identify and consider a reasonable number of regulatory alternatives and adopt the least costly, most cost-effective, or least burdensome alternative that achieves the objectives of the rule. The provisions of section 205 do not apply when they are inconsistent with applicable law. Moreover, section 205 allows the agency to adopt an alternative other than the least costly, most cost-effective, or least burdensome alternative if the agency publishes with the final rule an explanation of why that alternative was not adopted.

This final rule is not anticipated to result in the expenditure by State, local, or tribal governments, in the aggregate, or by the private sector in excess of \$112 million annually. Instead, the cost impact of this administrative rewrite of Standard No. 108 is expected to be \$0, because it does not change or increase the cost of existing requirements. Therefore, the agency has not prepared an economic assessment pursuant to the Unfunded Mandates Reform Act.

J. National Environmental Policy Act

NHTSA has analyzed this rulemaking action for the purposes of the National Environmental Policy Act. The agency has determined that implementation of this action would not have any significant impact on the quality of the human environment.

K. Regulatory Identifier Number (RIN)

The Department of Transportation assigns a regulation identifier number (RIN) to each regulatory action listed in the Unified Agenda of Federal Regulations. The Regulatory Information Service Center publishes the Unified Agenda in April and October of each year. You may use the RIN contained in the heading at the beginning of this document to find this action in the Unified Agenda.

L. Privacy Act

Please note that anyone is able to search the electronic form of all comments received into any of our dockets by the name of the individual submitting the comment (or signing the comment, if submitted on behalf of an association, business, labor union, etc.). You may review DOT's complete Privacy Act Statement in the **Federal Register** published on April 11, 2000 (Volume 65, Number 70; Pages 19477–78), or you may visit <http://dms.dot.gov>.

List of Subjects in 49 CFR Parts 564 and 571

Imports, Incorporation by reference, Motor vehicle safety, Motor vehicles, Report and recordkeeping requirements.

■ In consideration of the foregoing, NHTSA is amending 49 CFR parts 564 and 571 as follows:

PART 564—REPLACEABLE LIGHT SOURCE INFORMATION

■ 1. Part 564 is revised to read as follows:

PART 564—REPLACEABLE LIGHT SOURCE AND SEALED BEAM HEADLAMP INFORMATION

Sec.

564.1 Scope.

564.2 Purposes.

564.3 Applicability.

564.4 Definitions.

564.5 Information filing; agency processing of filings.

Appendix A to Part 564—Information to be Submitted for Replaceable Light Sources

Appendix B to Part 564—Information to be Submitted for Long Life Replaceable Light Sources of Limited Definition

Appendix C to Part 564—Information Applicable to Standardized Sealed Beam Headlamp Units

Authority: 49 U.S.C. 322, 30111, 30115, 30117, 30166; delegation of authority at 49 CFR 1.50.

§ 564.1 Scope.

This part requires the submission of dimensional, electrical specification, and marking/designation information as specified in Appendices A and B of this part, for original equipment replaceable

light sources used in motor vehicle headlighting systems. This part also serves as a repository for design information as specified in Appendix C of this part, for original equipment and replacement standardized sealed beam units used in motor vehicle headlighting systems.

§ 564.2 Purposes.

The purposes of this part are achieved through its Appendices:

(a) The purposes of Appendix A of this part are to ensure:

(1) The availability to replacement light source manufacturers of the manufacturing specifications of original equipment light sources so that replacement light sources are interchangeable with original equipment light sources and provide equivalent performance, and

(2) That redesigned or newly developed light sources are designated as distinct, different, and noninterchangeable with previously existing light sources.

(b) The purposes of Appendix B of this part are to ensure:

(1) That original equipment light sources are replaceable and that replacement light sources provide equivalent performance, and

(2) That redesigned or newly developed light sources are designated as distinct, different, and noninterchangeable with previously existing light sources.

(c) The purpose of Appendix C of this part is to ensure the availability to original equipment and replacement sealed beam headlamp manufacturers of the manufacturing specifications of standardized sealed beam headlamp units used on motor vehicles so that all sealed beam headlamp units of a specific type are interchangeable with all other units of that same type and provide equivalent performance.

§ 564.3 Applicability.

This part applies to replaceable light sources used as original equipment, and standardized sealed beam headlamp units used as original equipment and replacement equipment in motor vehicle headlighting systems.

§ 564.4 Definitions.

All terms defined in the Act and the regulations and standards issued under its authority are used as defined therein.

§ 564.5 Information filing; agency processing of filings.

(a) Each manufacturer of a motor vehicle, original equipment headlamp, or original equipment headlamp replaceable light source, which intends to manufacture a replaceable light

source as original equipment or to incorporate a replaceable light source in its headlamps or motor vehicles, shall furnish the information specified in Appendix A. If the rated laboratory life of the light source is not less than 2,000 hours, the manufacturer shall furnish the information specified in either Appendix A or Appendix B of this part. Information shall be furnished to:

Associate Administrator for Rulemaking, National Highway Traffic Safety Administration, 1200 New Jersey Avenue, SE., West Building, Washington, DC 20590 Attention: Part 564-Replaceable Light Source Information (unless the Agency has already filed such information in Docket No. NHTSA 98-3397).

(b) The manufacturer shall submit such information not later than 60 days before it intends to begin manufacture of the replaceable light source to which the information applies, or to incorporate the light source into a headlamp, or to incorporate the light source into a motor vehicle of its manufacture. Each submission shall consist of one original set of information and ten legible reproduced copies, all on 8½ by 11-inch paper.

(c) The Associate Administrator promptly reviews each submission and informs the manufacturer not later than 30 days after its receipt whether the submission has been accepted. Upon acceptance, the Associate Administrator files the information in Docket No. NHTSA 98-3397. The Associate Administrator does not accept any submission that does not contain all the information specified in Appendix A or Appendix B of this part, or whose accompanying information indicates that any new light source which is the subject of a submission is interchangeable with any replaceable light source for which the agency has previously filed information in Docket No. NHTSA 98-3397.

(d) A manufacturer may request modification of a light source for which information has previously been filed in Docket No. NHTSA 98-3397, and the submission shall be processed in the manner provided by § 564.5(c). A request for modification shall contain the following:

(1) All the information specified in Appendix A or Appendix B of this part that is relevant to the modification requested,

(2) The reason for the requested modification,

(3) A statement that the use of the light source as modified will not create a noncompliance with any requirement of Federal Motor Vehicle Safety Standard No. 108 (49 CFR 571.108)

when used to replace an unmodified light source in a headlamp certified by its manufacturer as conforming to all applicable Federal motor vehicle safety standards, together with reasons in support of the statement; and

(4) Information demonstrating that the modification would not adversely affect interchangeability with the original light source.

After review of the request for modification, the Associate Administrator may seek further information either from the manufacturer or through a notice published in the **Federal Register** requesting comment on whether a modified light source incorporating the changes requested will create a noncompliance with Federal Motor Vehicle Safety Standard No. 108 when substituted for an unmodified light source. If the Associate Administrator seeks public comment on a submission (s)he shall publish a notice stating whether (s)he has accepted or rejected the submission. If a submission is accepted, the Associate Administrator files the information in Docket No. NHTSA 98-3397. If a submission is rejected, a manufacturer may submit information with respect to it, as provides in paragraph 564.5(a), for consideration as a new light source after such changes as will insure that it is not interchangeable with the light source for which modification was originally requested.

(e) Information submitted under this section is made available by NHTSA for public inspection as soon as practicable after its receipt, but not later than the date on which a vehicle equipped with a new or revised replaceable light source is offered for sale.

Appendix A to Part 564—Information to be Submitted for Replaceable Light Sources

I. Filament or Discharge Arc Position Dimensions and Tolerances Using Either Direct Filament or Discharge Arc Dimensions or the Three Dimensional Filament or Discharge Arc Tolerance Box

A. Lower beam filament dimensions or filament tolerance box dimensions and relation of these to the bulb base reference plane and centerline.

1. Axial location of the filament centerline or the filament tolerance box relative to the bulb base reference plane.

2. Vertical location of the filament centerline or the filament tolerance box relative to the bulb base centerline.

3. Transverse location of the filament centerline or the filament tolerance box relative to the bulb base centerline.

4. Filament tolerance box dimensions, if used.

B. Upper beam filament dimensions or the filament tolerance box dimensions, and

relation of these to the bulb base reference plane and centerline.

1. Axial location of the filament centerline or the filament tolerance box relative to the bulb base reference plane.

2. Vertical location of the filament centerline or the filament tolerance box relative to the bulb base centerline.

3. Transverse location of the filament centerline or the filament tolerance box relative to the bulb base centerline.

4. Filament tolerance box dimensions, if used.

C. If the replaceable light source has both a lower beam and an upper beam filament, the dimensional relationship between the two filament centerlines or the filament tolerance boxes may be provided instead of referencing the upper beam filament centerline or filament tolerance box to the bulb base centerline or reference plane.

D. For a light source using excited gas mixtures as a filament, necessary fiducial information and specifications including electrode position dimensions and tolerance information that provide similar location and characteristics information required by paragraphs A, B, and C of this section I for light sources using a resistive type filament.

II. Dimensions Pertaining to Filament Capsule and Capsule Supports

A. Maximum length from bulb base reference plane to tip of filament capsule.

B. Maximum radial distances from bulb base centerline to periphery of filament capsule and/or supports.

C. Location of black cap relative to low beam filament centerline, filament tolerance box or other to-be-specified reference.

D. Size, length, shape, or other pertinent features and dimensions for providing undistorted walls for the filament capsule.

III. Bulb Base Interchangeability Dimensions and Tolerance

A. Angular locations, diameters, key/keyway sizes, and any other interchangeability dimensions for indexing the bulb base in the bulb holder.

B. Diameter, width, depth, and surface finish of seal groove, surface, or other pertinent sealing features.

C. Diameter of the bulb base at the interface of the base and its perpendicular reference surface.

D. Dimensions of features related to retention of the bulb base in the bulb holder such as tabs, keys, keyways, surfaces, etc.

IV. Bulb Holder Interchangeability Dimensions and Tolerance

A. Mating angular locations, diameters, key/keyway sizes, and any other interchangeability dimensions for indexing the bulb base in the bulb holder.

B. Mating diameter, width, depth, and surface finish of seal groove, surface, or other pertinent sealing features.

C. Mating diameter of the bulb holder at the interface of the bulb base aperture and its perpendicular reference surface.

D. Mating dimensions of features related to retention of the bulb base in the bulb holder such as tabs, keys, keyways, surfaces, etc.

V. Wiring Harness Connector to Bulb Base Interchangeability Dimensions and Tolerances

- A. Maximum depth of harness connector insertion into bulb base.
- B. Location of electrical pins in bulb base.
- C. Dimensions of electrical pins in bulb base—length, diameter, width, thickness and etc.
- D. Fit of harness connector into bulb base providing all necessary dimensions, key/keyway controls, and dimensions, tapers etc.
- E. Dimensions and location of locking features for wiring harness connector to bulb base.
- F. Identification of upper beam, lower beam, and common terminals.

VI. Seal Specifications (if Replaceable Light Source is Intended to be of a Sealed Base Design)

- A. Type.
- B. Material.
- C. Dimensions.

VII. Electrical Specifications for Each Filament at 12.8 Volts

- A. Maximum power (in watts).
- B. Luminous Flux with tolerance (in lumens) with black cap if so equipped, measured in accordance with the document: Illuminating Engineering Society of North America, LM-45; IES Approved Method for Electrical and Photometric Measurements of General Service Incandescent Filament Lamps (April 1980). This incorporation by reference was approved by the Director of the Federal Register in accordance with 5 U.S.C. 552(a) and 1 CFR Part 51. Copies may be obtained from the Illuminating Engineering Society of North America, 345 East 47th St., New York, NY 10017. Copies may be inspected at the National Highway Traffic Safety Administration, Technical Information Services, 1200 New Jersey Avenue, Washington, DC 20590, or at the National Archives and Records Administration (NARA). For information on the availability of this material at NARA, call 202-741-6030, or go to: http://www.archives.gov/federal_register/code_of_federal_regulations/ibr_locations.html.

VIII. Bulb Markings/Designation—ANSI NUMBER, ECE IDENTIFIER, MANUFACTURER'S PART NUMBER, INDIVIDUALLY OR IN ANY COMBINATION

IX. All Other Information, Dimensions or Performance Specifications Necessary for Interchangeability, Replaceability, or System Test Purposes not Listed in Sections I Through VIII

IF A BALLAST IS REQUIRED FOR OPERATION, A COMPLETE LISTING OF THE REQUIREMENTS AND PARAMETERS BETWEEN THE LIGHT SOURCE AND BALLAST, AND BALLAST AND THE VEHICLE SHALL ALSO BE PROVIDED.

Appendix B to Part 564—Information to be Submitted for Long Life Replaceable Light Sources of Limited Definition

I. Filament or Discharge Arc Position Dimensions and Tolerances Using Either Direct Filament or Discharge Arc Dimensions or the Three Dimensional Filament Discharge Arc Tolerance Box

A. Lower beam filament or discharge arc dimensions or filament or discharge arc tolerance box dimensions and relation of these to the bulb base reference plane and centerline.

1. Axial location of the filament or discharge arc centerline or the filament or discharge arc tolerance box relative to the bulb base reference plane.

2. Vertical location of the filament or discharge arc centerline or the filament or discharge arc tolerance box relative to the bulb base centerline.

3. Transverse location of the filament or discharge arc centerline or the filament or discharge arc tolerance box relative to the bulb base centerline.

4. Filament or discharge arc tolerance box dimensions, if used.

B. Upper beam filament or discharge arc dimensions or the filament or discharge arc tolerance box dimensions and relation of these to the bulb base reference plane and centerline.

1. Axial location of the filament or discharge arc centerline or the filament or discharge arc tolerance box relative to the bulb base reference plane.

2. Vertical location of the filament or discharge arc centerline or the filament or discharge arc tolerance box relative to the bulb base centerline.

3. Transverse location of the filament or discharge arc centerline or the filament or discharge arc tolerance box relative to the bulb base centerline.

4. Filament or discharge arc tolerance box dimensions, if used.

C. If the replaceable light source has both a lower beam and upper beam filament or discharge arc, the dimensional relationship between the two filament or discharge arc centerlines or the filament or discharge arc tolerance boxes may be provided instead of referencing the upper beam filament or discharge arc centerline or filament or discharge arc tolerance box to the bulb base centerline or reference plane.

D. For a light source using excited gas mixtures as a filament, necessary fiducial information and specifications including electrode position dimensions, and tolerance information that provide similar location and characteristics information required by paragraphs A, B, and C of this section I for light sources using a resistive type filament.

II. Bulb Base Interchangeability Dimensions and Tolerance

A. Angular locations, diameters, key/keyway sizes, and any other interchangeability dimensions for indexing the bulb base in the bulb holder.

B. Diameter, width, depth, and surface finish of seal groove, surface, or other pertinent sealing features.

C. Diameter of the bulb base at the interface of the base and its perpendicular reference surface.

D. Dimensions of features related to retention of the bulb base in the bulb holder such as tabs, keys, keyways, surface, etc.

III. Bulb Holder Interchangeability Dimensions and Tolerances

A. Mating angular locations, diameters, key/keyway sizes, any other interchangeability dimensions for indexing the bulb base in the bulb holder.

B. Mating diameter, width, depth, and surface, or other pertinent sealing features.

C. Mating diameter of the bulb holder at the interface of the bulb base aperture and its perpendicular reference surface.

D. Mating dimensions of features related to retention of the bulb base in the bulb holder such as tabs, keys, keyways, surface, or any other characteristics necessary for mating dimensions.

IV. Electrical Specifications for Each Light Source That Operates With a Ballast and Rated Life of the Light Source/Ballast Combination

A. Maximum power (in watts).

B. Luminous Flux (in lumens).

C. Rated laboratory life of the light source/ballast combination (not less than 2,000 hours).

V. Applicable to Light Sources That Operate With a Source Voltage Other Than 12.8 Volts Direct Current, and When a Proprietary Ballast Must Be Used With the Light Source

A. Manufacturer's part number for the ballast.

B. Any other characteristics necessary for system operation.

VI. Bulb Markings/Designation—ANSI NUMBER, ECE IDENTIFIER, MANUFACTURER'S PART NUMBER, INDIVIDUAL OR IN ANY COMBINATION

VII. All Other Identification, Dimensions or Performance Specifications Necessary for Replaceability or Systems Test Not Listed in Sections I Through VI

Appendix C to Part 564—Information Applicable to Standardized Sealed Beam Headlamp Units

I. Dimensional Information Specific to a Type of Standardized Sealed Beam Unit.

A. Dimensions marked "I", indicating interchangeability, for which conformance is mandatory.

B. All other dimensions which are for design purposes.

II. Dimensional Information Applicable to the Use of Nonadjustable Headlamp Aiming Device Locating Plates

III. Dimensional Information Applicable to Mounting Features, Including Mounting Rings and Lamp Bodies, Specific to a Type of Standardized Sealed Beam Unit

A. Dimensions marked "I", indicating interchangeability, for which conformance is mandatory.

B. All other dimensions which are for design purposes.

Incorporated Figures [References from 49 CFR 571.108, Oct. 1, 2006]

LF Headlamp Dimensional Information [Figure 11]

UF Headlamp Dimensional Information [Figure 12]

LF/UF Mounting Features [Figure 13]

LF/UF Mounting Ring [Figure 14]

Type G & H Headlamp Dimensional Information [Figure 18]

Type G & H Headlamp Mounting Information [Figure 21]

Type 1A1 Headlamp Dimensional Information [SAE J1383 APR85, Figure 11]

Type 2A1 Headlamp Dimensional Information [SAE J1383 APR85, Figure 10]

Type 2B1 Headlamp Dimensional Information [SAE J1383 APR85, Figure 13]

Type 1C1 Headlamp Dimensional Information [SAE J1383 APR85, Figure 7]

Type 2C1 Headlamp Dimensional Information [SAE J1383 APR85, Figure 8]

Type 2D1 Headlamp Dimensional Information [SAE J1383 APR85, Figure 5]

Type 2E1 Headlamp Dimensional Information [SAE J1383 APR85, Figure 15]

Types 1A1, 2A1, and 2E1 Headlamp Mounting Ring/Lamp Body Dimensional Information [SAE J1383 APR85, Figure 12]

Type 2B1 Headlamp Mounting Ring/Lamp Body Dimensional Information [SAE J1383 APR85, Figure 14]

Types 1C1 and 2C1 Headlamp Mounting Ring/Lamp Body Dimensional Information [SAE J1383 APR85, Figure 9]

Type 2D1 Headlamp Mounting Ring/Lamp Body Dimensional Information [SAE J1383 APR85, Figure 6]

PART 571—FEDERAL MOTOR VEHICLE SAFETY STANDARDS

■ 2. The authority citation for Part 571 continues to read as follows:

Authority: 49 U.S.C. 322, 30111, 30115, 30117, 30166; delegation of authority at 49 CFR 1.50.

■ 3. Section 571.108 is amended to read as follows:

§ 571.108 Standard No. 108; Lamps, reflective devices, and associated equipment.

S1 Scope. This standard specifies requirements for original and replacement lamps, reflective devices, and associated equipment.

S2 Purpose. The purpose of this standard is to reduce traffic accidents and deaths and injuries resulting from traffic accidents, by providing adequate illumination of the roadway, and by enhancing the conspicuity of motor vehicles on the public roads so that their presence is perceived and their signals understood, both in daylight and in darkness or other conditions of reduced visibility.

S3 Application. This standard applies to:

S3.1 Passenger cars, multipurpose passenger vehicles, trucks, buses,

trailers (except pole trailers and trailer converter dollies), and motorcycles;

S3.2 Retroreflective sheeting and reflex reflectors manufactured to conform to S8.2 of this standard; and

S3.3 Lamps, reflective devices, and associated equipment for replacement of like equipment on vehicles to which this standard applies.

S4 Definitions.

Aiming plane means a plane defined by the surface of the three aiming pads on the lens.

Aiming reference plane means a plane which is perpendicular to the longitudinal axis of the vehicle and tangent to the forwardmost aiming pad on the headlamp.

Aiming screws are the horizontal and vertical adjusting screws with self-locking features used to aim and retain a headlamp unit in the proper position.

Axis of reference means the characteristic axis of the lamp for use as the direction of reference ($H = 0^\circ$, $V = 0^\circ$) for angles of field for photometric measurements and for installing the lamp on the vehicle.

Backup lamp means a lamp or lamps which illuminate the road to the rear of a vehicle and provide a warning signal to pedestrians and other drivers when the vehicle is backing up or is about to back up.

Beam contributor means an indivisible optical assembly including a lens, reflector, and light source, that is part of an integral beam headlighting system and contributes only a portion of a headlamp beam.

Cargo lamp is a lamp that is mounted on a multipurpose passenger vehicle, truck, or bus for the purpose of providing illumination to load or unload cargo.

Clearance lamps are lamps which show to the front or rear of the vehicle, mounted on the permanent structure of the vehicle as near as practicable to the upper left and right extreme edges to indicate the overall width and height of the vehicle.

Coated materials means a material which has a coating applied to the surface of the finished sample to impart some protective properties. Coating identification means a mark of the manufacturer's name, formulation designation number, and recommendations for application.

Color Fundamental definitions of color are expressed by Chromaticity Coordinates according to the International Commission on Illumination (C.I.E.) 1931 Standard Colorimetric System, as described in the CIE 1931 Chromaticity Diagram (incorporated by reference, see 571.108 S5.2 of this title).

Color bleeding means the migration of color out of a plastic part onto the surrounding surface.

Combination clearance and side marker lamps are single lamps which simultaneously fulfill the requirements of clearance and side marker lamps.

Cracking means a separation of adjacent sections of a plastic material with penetration into the specimen.

Crazing means a network of apparent fine cracks on or beneath the surface of materials.

Cutoff means a generally horizontal, visual/optical aiming cue in the lower beam that marks a separation between areas of higher and lower luminance.

Daytime running lamps (DRLs) are steady burning lamps that are used to improve the conspicuity of a vehicle from the front and front sides when the regular headlamps are not required for driving.

Delamination means a separation of the layers of a material including coatings.

Design voltage means the voltage used for design purposes.

Direct reading indicator means a device that is mounted in its entirety on a headlamp or headlamp aiming or headlamp mounting equipment, is part of a VHAD, and provides information about headlamp aim in an analog or digital format.

Effective light-emitting surface means that portion of a lamp that directs light to the photometric test pattern, and does not include transparent lenses, mounting hole bosses, reflex reflector area, beads or rims that may glow or produce small areas of increased intensity as a result of uncontrolled light from an area of $\frac{1}{2}^\circ$ radius around a test point.

Effective projected luminous lens area means the area of the orthogonal projection of the effective light-emitting surface of a lamp on a plane perpendicular to a defined direction relative to the axis of reference. Unless otherwise specified, the direction is coincident with the axis of reference.

Exposed means material used in lenses or optical devices exposed to direct sunlight as installed on the vehicle.

Filament means that part of the light source or light emitting element(s), such as a resistive element, the excited portion of a specific mixture of gases under pressure, or any part of other energy conversion sources, that generates radiant energy which can be seen.

Flash means a cycle of activation and deactivation of a lamp by automatic means continuing until stopped either automatically or manually.

Fully opened means the position of the headlamp concealment device in which the headlamp is in the design open operating position.

H-V axis means the line from the center of the principal filament of a lamp to the intersection of the horizontal (H) and vertical (V) lines of a photometric test screen.

Haze means the cloudy or turbid appearance of an otherwise transparent specimen caused by light scattered from within the specimen or from its surface.

Headlamp means a lighting device providing an upper and/or a lower beam used for providing illumination forward of the vehicle.

Headlamp concealment device means a device, with its operating system and components, that provides concealment of the headlamp when it is not in use, including a movable headlamp cover and a headlamp that displaces for concealment purposes.

Headlamp mechanical axis means the line formed by the intersection of a horizontal and a vertical plane through the light source parallel to the longitudinal axis of the vehicle. If the mechanical axis of the headlamp is not at the geometric center of the lens, then the location will be indicated by the manufacturer on the headlamp.

Headlamp test fixture means a device designed to support a headlamp or headlamp assembly in the test position specified in the laboratory tests and whose mounting hardware and components are those necessary to operate the headlamp as installed in a motor vehicle.

High-mounted stop lamp means a lamp mounted high and possibly forward of the tail, stop, and rear turn signal lamps intended to give a steady stop warning through intervening vehicles to operators of following vehicles.

Identification lamps are lamps used in groups of three, in a horizontal row, which show to the front or rear or both, having lamp centers spaced not less than [6 in] 15.2 mm nor more than [12 in] 30.4 mm apart, mounted on the permanent structure as near as practicable to the vertical centerline and the top of the vehicle to identify certain types of vehicles.

Integral beam headlamp means a headlamp (other than a standardized sealed beam headlamp designed to conform to paragraph S10.13 or a replaceable bulb headlamp designed to conform to paragraph S10.15) comprising an integral and indivisible optical assembly including lens, reflector, and light source, except that a headlamp conforming to paragraph

S10.18.8 or paragraph S10.18.9 may have a lens designed to be replaceable.

License plate lamp means a lamp used to illuminate the license plate on the rear of a vehicle.

Lower beam means a beam intended to illuminate the road and its environs ahead of the vehicle when meeting or closely following another vehicle.

Material means the type and grade of plastics, composition, and manufacturer's designation number and color.

Mechanically aimable headlamp means a headlamp having three pads on the lens, forming an aiming plane used for laboratory photometric testing and for adjusting and inspecting the aim of the headlamp when installed on the vehicle.

Motor driven cycle means every motorcycle, including every motor scooter, with a motor which produces not more than 5 horsepower, and every bicycle with motor attached.

Motorcycle or motor driven cycle headlamp means a major lighting device used to produce general illumination ahead of the vehicle.

Mounting ring means the adjustable ring upon which a sealed beam unit is mounted.

Mounting ring (type F sealed beam) means the adjustable ring upon which a sealed beam unit is mounted and which forces the sealed beam unit to seat against the aiming ring when assembled into a sealed beam assembly.

Multiple compartment lamp means a device which gives its indication by two or more separately lighted areas which are joined by one or more common parts, such as a housing or lens.

Multiple lamp arrangement means an array of two or more separate lamps on each side of the vehicle which operate together to give a signal.

Optically combined means a lamp having a single or two filament light source or two or more separate light sources that operate in different ways, and has its optically functional lens area wholly or partially common to two or more lamp functions.

Overall width means the nominal design dimension of the widest part of the vehicle, exclusive of signal lamps, marker lamps, outside rearview mirrors, flexible fender extensions, mud flaps, and outside door handles determined with doors and windows closed, and the wheels in the straight-ahead position. Running boards may also be excluded from the determination of overall width if they do not extend beyond the width as determined by the other items excluded by this definition.

Parking lamps are lamps on both the left and right of the vehicle which show

to the front and are intended to mark the vehicle when parked or serve as a reserve front position indicating system in the event of headlamp failure.

Protected means material used in inner lenses for optical devices where such lenses are protected from exposure to the sun by an outer lens made of materials meeting the requirements for exposed plastics.

Rated voltage means the nominal circuit or vehicle electrical system voltage classification.

Reflex reflectors are devices used on vehicles to give an indication to approaching drivers using reflected light from the lamps of the approaching vehicle.

Remote reading indicator means a device that is not mounted in its entirety on a headlamp or headlamp aiming or headlamp mounting equipment, but otherwise meets the definition of a direct reading indicator.

Replaceable bulb headlamp means a headlamp comprising a bonded lens and reflector assembly and one or two replaceable light sources, except that a headlamp conforming to paragraph S10.18.8 or paragraph S10.18.9 may have a lens designed to be replaceable.

Replaceable light source means an assembly of a capsule, base, and terminals that is designed to conform to the requirements of Appendix A or Appendix B of 49 CFR part 564 *Replaceable Light Source Information* of this Chapter.

Retaining ring means the clamping ring that holds a sealed beam unit against a mounting ring.

Retaining ring (type F sealed beam) means the clamping ring that holds a sealed beam unit against a mounting ring, and that provides an interface between the unit's aiming/seating pads and the headlamp aimer adapter (locating plate).

School bus signal lamps are alternately flashing lamps mounted horizontally both front and rear, intended to identify a vehicle as a school bus and to inform other users of the highway that such vehicle is stopped on the highway to take on or discharge school children.

Sealed beam headlamp means an integral and indivisible optical assembly including the light source with "SEALED BEAM" molded in the lens.

Sealed beam headlamp assembly means a major lighting assembly which includes one or more sealed beam units used to provide general illumination ahead of the vehicle.

Seasoning means the process of energizing the filament of a headlamp at design voltage for a period of time equal

to 1% of design life, or other equivalent method.

Semiautomatic headlamp beam switching device is one which provides either automatic or manual control of beam switching at the option of the driver. When the control is automatic the headlamps switch from the upper beam to the lower beam when illuminated by the headlamps on an approaching vehicle and switch back to the upper beam when the road ahead is dark. When the control is manual, the driver may obtain either beam manually regardless of the conditions ahead of the vehicle.

Side marker lamps are lamps which show to the side of the vehicle, mounted on the permanent structure of the vehicle as near as practicable to the front and rear edges to indicate the overall length of the vehicle. Additional lamps may also be mounted at intermediate locations on the sides of the vehicle.

Stop lamps are lamps giving a steady light to the rear of a vehicle to indicate a vehicle is stopping or diminishing speed by braking.

Taillamps are steady burning low intensity lamps used to designate the rear of a vehicle.

Test voltage means the specified voltage and tolerance to be used when conducting a test.

Turn signal lamps are the signaling element of a turn signal system which indicates the intention to turn or change direction by giving a flashing light on the side toward which the turn will be made.

Turn signal flasher means a device which causes a turn signal lamp to flash as long as it is turned on.

Turn signal operating unit means an operating unit that is part of a turn signal system by which the operator of a vehicle causes the signal units to function.

Upper beam means a beam intended primarily for distance illumination and for use when not meeting or closely following other vehicles.

Vehicle headlamp aiming device or VHAD means motor vehicle equipment, installed either on a vehicle or headlamp, which is used for determining the horizontal or vertical aim, or both the vertical and horizontal aim of the headlamp.

Vehicular hazard warning signal flasher means a device which, as long as it is turned on, causes all the required turn signal lamps to flash.

Vehicular hazard warning signal operating unit means a driver controlled device which causes all required turn signal lamps to flash simultaneously to

indicate to approaching drivers the presence of a vehicular hazard.

Visually/optically aimable headlamp means a headlamp which is designed to be visually/optically aimable in accordance with the requirements of paragraph S10.18.9 of this standard.

S5 References to SAE publications.
S5.1 Each required lamp, reflective device, and item of associated equipment must be designed to conform to the requirements of applicable SAE publications as referenced and subreferenced in this standard. The words "it is recommended that," "recommendations," or "should be" appearing in any SAE publication referenced or subreferenced in this standard must be read as setting forth mandatory requirements.

S5.2 *Incorporation by reference.* The Director of the Federal Register approves the incorporation by reference of the following material in accordance with 5 U.S.C. 552(a) and 1 CFR Part 51. All material is available for inspection at the NHTSA Reading Room, 1200 New Jersey Avenue, SE., Washington, DC 20590, or at NARA. For information on the availability of this material at NARA, call 202-741-6030, or go to: http://www.archives.gov/federal_register/code_of_federal_regulations/ibr_locations.html.

The material is also available at the publisher whose name and address follow the standard number:

1. Society of Automotive Engineers (SAE) Standard J602, revised AUG 1963, "Headlamp Aiming Device for Mechanically Aimable Sealed Beam Headlamp Units." Society of Automotive Engineers, Inc., 400 Commonwealth Drive, Warrendale, PA 15096.

2. Society of Automotive Engineers (SAE) Standard J941b, revised FEB 1969, "Motor Vehicle Driver's Eye Range." Society of Automotive Engineers, Inc., 400 Commonwealth Drive, Warrendale, PA 15096.

3. Society of Automotive Engineers (SAE) Standard J602, revised OCT 1980, "Headlamp Aiming Device for Mechanically Aimable Sealed Beam Headlamp Units." Society of Automotive Engineers, Inc., 400 Commonwealth Drive, Warrendale, PA 15096.

4. Society of Automotive Engineers (SAE) Standard J2009, revised FEB 1993, "Forward Discharge Lighting Systems." Society of Automotive Engineers, Inc., 400 Commonwealth Drive, Warrendale, PA 15096.

5. Society of Automotive Engineers (SAE) Standard J573d, revised DEC 1968, "Lamp Bulbs and Sealed Units."

Society of Automotive Engineers, Inc., 400 Commonwealth Drive, Warrendale, PA 15096.

6. Society of Automotive Engineers (SAE) Standard J567b, revised APR 1964, "Bulb Sockets." Society of Automotive Engineers, Inc., 400 Commonwealth Drive, Warrendale, PA 15096.

7. International Commission on Illumination (C.I.E.) 1931 Chromaticity Diagram. CIE Central Bureau, Kegelgasse 27, A-1030 Vienna, Austria.

8. General Services Administration (GSA) Federal Specification L-S-300, approved September 1965, "Sheeting and Tape, Reflective: Nonexposed Lens, Adhesive Backing." Superintendent of Documents, U.S. Government Printing Office, Washington, DC 20402, telephone 202-512-1800.

9. American Society for Testing and Materials (ASTM) D4956-90, published December 1990, "Standard Specification for Retroreflective Sheeting for Traffic Control." ASTM International, 100 Barr Harbor Drive, PO Box C700, Conshohocken, PA 19428-2959.

10. ECE 48 E/ECE/324-E/ECE/TRANS/505, Rev.1/ADD.47/Rev.1/Corr.2, 26 February 1996, "Uniform Provisions Concerning the Approval of Vehicles with Regard to the Installation of Lighting and Light-Signaling Devices." United Nations, Conference Services Division, Distribution and Sales Section, Office C.115-1, Palais des Nations, CH-1211, Geneva 10, <http://www.unece.org/trans/main/wp29/wp29regs.html>.

11. American Society for Testing and Materials (ASTM) D1003-92, published December 1992, "Standard Test Method for Haze and Luminous Transmittance of Transparent Plastics." ASTM International, 100 Barr Harbor Drive, PO Box C700, Conshohocken, PA 19428-2959.

12. American Society for Testing and Materials (ASTM) E308-66, reapproved 1981, "Standard Practice for Spectrophotometry and Description of Color in CIE 1931 System." ASTM International, 100 Barr Harbor Drive, PO Box C700, Conshohocken, PA 19428-2959.

13. American Society for Testing and Materials (ASTM) B117-73, reapproved 1979, "Standard Method of Salt Spray (Fog) Testing." ASTM International, 100 Barr Harbor Drive, PO Box C700, Conshohocken, PA 19428-2959.

14. American Society for Testing and Materials (ASTM) Co. 05.04 1985, "Annual Book of ASTM Standards: Test Methods for Rating Motor, Diesel, Aviation Fuels," Section I, parts A2.3.2, A2.3.3, and A2.7 in Annex 2. ASTM International, 100 Barr Harbor Drive, PO

Box C700, Conshohocken, PA 19428–2959.

15. American Society for Testing and Materials (ASTM) D362–84, published March 1984, “Standard Specification for Industrial Grade Toluene.” ASTM International, 100 Barr Harbor Drive, PO Box C700, Conshohocken, PA 19428–2959.

16. American Society for Testing and Materials (ASTM) C150–77, published April 1977, “Standard Specification for Portland Cement.” ASTM International, 100 Barr Harbor Drive, PO Box C700, Conshohocken, PA 19428–2959.

17. Illuminating Engineering Society of North America (IES) LM 45, approved April 1980, “IES Approved Method for Electrical and Photometric Measurements of General Service Incandescent Filament Lamps.” Illuminating Engineering Society of North America, 345 East 47th St., New York, NY 10017.

S6 Vehicle requirements.

S6.1 *Required lamps, reflective devices, and associated equipment by vehicle type.*

S6.1.1 *Quantity.* Except as provided in succeeding paragraphs of this S6.1.1 each vehicle must be equipped with at least the number of lamps, reflective devices, and items of associated equipment specified for that vehicle type and size in Table I and Section 6.6, designed to conform to the requirements of this standard. Multiple license plate lamps and backup lamps may be used to fulfill photometric requirements for those functions.

S6.1.1.1 *Conspicuity systems.* Each trailer of 2032 mm or more in overall width, and with a GVWR over 10,000 lbs., except a trailer designed exclusively for living or office use, and each truck tractor must be equipped with retroreflective sheeting, reflex reflectors, or a combination of retroreflective sheeting and reflex reflectors as specified in S8.2.

S6.1.1.2 *High-mounted stop lamps.* Each multipurpose passenger vehicle, truck, and bus required by this standard to be equipped with a high-mounted stop lamp, whose vertical centerline, when the vehicle is viewed from the rear, is not located on a fixed body panel but separates one or two moveable body sections, such as doors, which lacks sufficient space to install a single high-mounted stop lamp on the centerline above such body sections, must have two high-mounted stop lamps identical in size and shape.

S6.1.1.2.1 The two lamps must be located at the same height, with one vertical edge of each lamp on the vertical edge of the body section nearest the vehicle centerline.

S6.1.1.3 *Truck tractor rear turn signal lamps.* A truck tractor need not be equipped with turn signal lamps mounted on the rear if the turn signal lamps installed at or near the front are of double face construction and are located such that they meet the photometric requirements for double faced turn signal lamps specified in Footnote 6 of Table VII.

S6.1.1.3.1 The flashing signal from a double faced signal lamp must not be obliterated when subjected to external light rays from either in front or behind, at any and all angles.

S6.1.1.4 *Daytime running lamps.* A passenger car, multipurpose passenger vehicle, truck, or bus may be equipped with a pair of daytime running lamps (DRLs) as specified in Table I and S7.10 of this standard. DRLs may be any pair of lamps on the front of the vehicle, whether or not required by this standard, other than parking lamps or fog lamps.

S6.1.2 *Color.* The color in all lamps and reflective devices to which this standard applies must be as specified in Table I. The color identified as amber is identical to the color identified as yellow.

S6.1.3 *Mounting location.*

S6.1.3.1 Each lamp, reflective device, and item of associated equipment must be securely mounted on a rigid part of the vehicle, other than glazing, that is not designed to be removed except for repair, within the mounting location and height limits as specified in Table I, and in a location where it complies with all applicable photometric requirements, effective projected luminous lens area requirements, and visibility requirements with all obstructions considered.

S6.1.3.2 When multiple lamp arrangements or multiple compartment rear turn signal lamps, stop lamps, or taillamps are used, with only a portion of the compartments or lamps installed on a rigid part of the vehicle, that portion must meet at least the photometric requirements for the applicable single compartment lamp.

S6.1.3.3 *License plate lamp.* The license plate lamp or lamps installed on vehicles other than motorcycles and motor driven cycles must be mounted so as to illuminate the license plate without obstruction from any designed feature unless the lamp or lamps is (are) designed to comply with all the photometric requirements with these obstructions considered.

S6.1.3.4 *High-mounted stop lamps.*

S6.1.3.4.1 *Interior mounting.* A high-mounted stop lamp mounted inside the vehicle must have means provided to

minimize reflections from the light of the lamp upon the rear window glazing that might be visible to the driver when viewed directly, or indirectly in the rearview mirror.

S6.1.3.4.2 *Accessibility.* Each high-mounted stop lamp must provide access for convenient replacement of bulbs without special tools.

S6.1.3.5 *Headlamp beam mounting.*

S6.1.3.5.1 *Vertical headlamp arrangement.*

S6.1.3.5.1.1 Where multiple headlamps with single light sources are installed in a vertical orientation the lower beam must be provided by the uppermost headlamp.

S6.1.3.5.1.2 Where headlamps with two vertically oriented light sources are installed the lower beam must be provided by the uppermost light source or by all light sources.

S6.1.3.5.1.3 Where more than one lamp must be used for a motorcycle headlighting system, the lamps must be mounted vertically, with the lower beam as high as practicable.

S6.1.3.5.2 *Horizontal headlamp arrangement.*

S6.1.3.5.2.1 Where multiple headlamps with single light sources are installed in a horizontal orientation the lower beam must be provided by the most outboard headlamp.

S6.1.3.5.2.2 Where headlamps with two horizontally oriented light sources are installed the lower beam must be provided by the outboard light source or by all light sources.

S6.1.3.6 *Auxiliary lamps mounted near identification lamps.* Each auxiliary lamp must be located at least twice the distance from any required identification lamp as the distance between two adjacent required identification lamps.

S6.1.4 *Mounting height.* The mounting height of each lamp and reflective device must be measured from the center of the item, as mounted on the vehicle at curb weight, to the road surface.

S6.1.4.1 *High-mounted stop lamps.*

S6.1.4.1.1 A high-mounted stop lamp mounted below the rear window must have no lens portion lower than 153 mm [6 in] below the lower edge of the rear glazing on convertibles, or 77 mm [3 in] on other passenger cars.

S6.1.5 *Activation.* Each lamp must be activated as specified, in the combinations specified, and in response to the inputs specified in Table I and Table II.

S6.1.5.1 *Hazard warning signal.* In all passenger cars, multipurpose passenger vehicles, trucks, and buses, the activation of the vehicular hazard warning signal operating unit must

cause to flash simultaneously sufficient turn signal lamps to meet, as a minimum, the turn signal photometric requirements of this standard.

S6.1.5.2 *Simultaneous beam activation.*

S6.1.5.2.1 On any vehicle to which this standard applies where the headlighting system is designed to conform to the photometric requirements of UB1 of Table XVIII and LB1M or LB1V of Table XIX-a, the lamps marked "L" or "LF" may remain permanently activated when the lamps marked "U" or "UF" are activated.

S6.1.5.2.2 On any vehicle to which this standard applies where an integral beam headlighting system is designed to conform to the photometric requirements of UB6 of Table XVIII and LB5M of Table XIX-b or LB4V of Table XIX-c, the lower beam headlamps must remain permanently activated when the upper beam headlamps are activated.

S6.1.5.2.3 On any vehicle to which this section applies where the headlighting system is designed to conform to the photometric requirements of UB2 of Table XVIII and LB2M or LB2V of Table XIX-a, a lower beam light source may remain permanently activated when an upper beam light source is activated if the lower beam light source contributes to the upper beam photometric compliance of the headlighting system.

S6.2 *Impairment.*

S6.2.1 No additional lamp, reflective device, or other motor vehicle equipment is permitted to be installed that impairs the effectiveness of lighting equipment required by this standard.

S6.2.2 If any required lamp or reflective device is obstructed by motor vehicle equipment (e.g., mirrors, snow plows, wrecker booms, backhoes, winches, etc.) including dealer installed equipment, and cannot meet the applicable photometry and visibility requirements, the vehicle must be equipped with an additional lamp or device of the same type which meet all applicable requirements of this standard, including photometry and visibility.

S6.2.3 *Headlamp obstructions.*

S6.2.3.1 When activated in a steady burning state, headlamps must not have any styling ornament or other feature, such as a translucent cover or grill, in front of the lens.

S6.2.3.2 Headlamp wipers may be used in front of the lens provided that the headlamp system is designed to conform with all applicable photometric requirements with the wiper stopped in any position in front of the lens.

S6.3 *Equipment combinations.* Two or more lamps, reflective devices, or

items of associated equipment may be combined if the requirements for each lamp, reflective device, and item of associated equipment are met with the following exceptions:

S6.3.1 No high-mounted stop lamp is permitted to be combined with any other lamp or reflective device, other than with a cargo lamp.

S6.3.2 No high-mounted stop lamp is permitted to be optically combined with any cargo lamp.

S6.3.3 No clearance lamp is permitted to be optically combined with any taillamp.

S6.4 *Lens area, visibility and school bus signal lamp aiming.*

S6.4.1 *Effective projected luminous lens area.* Each turn signal lamp, stop lamp, high-mounted stop lamp, and school bus signal lamp must meet the applicable effective projected luminous lens area requirement specified in Tables IV-a, IV-b, and IV-c.

S6.4.2 *Visibility.* Each backup lamp, single or combination of dual high-mounted stop lamp(s), and school bus signal lamp must meet the applicable visibility requirement specified in Table V-a.

S6.4.3 *Visibility options.* A manufacturer must certify compliance of each lamp function to one of the following visibility requirement options, and it may not thereafter choose a different option for that vehicle:

(a) *Lens area option.* When a vehicle is equipped with any lamp listed in Table V-b each such lamp must provide not less than 1250 sq mm of unobstructed effective projected luminous lens area in any direction throughout the pattern defined by the corner points specified in Table V-b for each such lamp; or

(b) *Luminous intensity option.* When a vehicle is equipped with any lamp listed in Table V-c each such lamp must provide a luminous intensity of not less than that specified in Table V-c in any direction throughout the pattern defined by the corner points specified in Table V-c for each such lamp when measured in accordance with the photometry test requirements of this standard.

S6.4.4 *Legacy visibility alternative.* As an alternative to S6.4.3, each passenger car and motorcycle, and each multipurpose passenger vehicle, truck, trailer, and bus that is of less than 2032 mm overall width, that are manufactured on or before September 1, 2011, and each multipurpose passenger vehicle, truck, trailer, and bus that is of 2032 mm or more overall width, that are manufactured on or before September 1, 2014, must have each lamp located so that it meets the visibility requirements specified in Table V-d.

S6.4.5 *School bus signal lamp aiming.* Each school bus signal lamp must be mounted on the vehicle with their aiming plane vertical and normal to the vehicle longitudinal axis. Aim tolerance must be no more than 5 in vertically and 10 in horizontally at 25 ft from the lamp. If the lamps are aimed or inspected by use of the SAE J602, *Headlamp Aiming Device for Mechanically Aimable Sealed Beam Headlamp Units*, (August 1963) (incorporated by reference, see 571.108 S5.2 of this title), the graduation settings for aim must be 2° D and 0° sideways for aiming and the limits must be 3° U to 7° D and from 10° R to 10° L for inspection.

S6.5 *Marking.* A summary of the marking requirements of this standard and their location in the standard is contained in Table III.

S6.5.1 *DOT marking.* The lens of each original equipment and replacement headlamp, and of each original equipment and replacement beam contributor, and each replacement headlamp lens for an integral beam or replaceable bulb headlamp, must be marked with the symbol "DOT" either horizontally or vertically to indicate certification under 49 U.S.C. 30115.

S6.5.1.1 The DOT marking requirements for conspicuity materials are specified in S8.2 of this standard.

S6.5.1.2 Each original equipment or replacement lamp or reflective device specified in Table I, except for a headlamp, or an item of associated equipment specified in S9 may be marked with the symbol "DOT" which constitutes a certification that it conforms to the requirements of this standard.

S6.5.2 *DRL marking.* Each original equipment and replacement lamp used as a daytime running lamp (DRL), unless optically combined with a headlamp, must be permanently marked "DRL" on its lens in letters not less than 3 mm high.

S6.5.3 *Headlamp markings.*

S6.5.3. *Trademark.* The lens of each original and replacement equipment headlamp, and of each original and replacement equipment beam contributor must be marked with the name and/or trademark registered with the U.S. Patent and Trademark Office of the manufacturer of such headlamp or beam contributor, of its importer, or any manufacturer of a vehicle equipped with such headlamp or beam contributor. Nothing in this standard authorizes the marking of any such name and/or trademark by one who is not the owner, unless the owner has consented to it.

S6.5.3.2 Voltage and trade number. Each original and replacement equipment headlamp, and each original and replacement equipment beam contributor must be marked with its voltage and with its part or trade number.

S6.5.3.3 Sealed beam headlamp markings.

S6.5.3.3.1 Each sealed beam headlamp lens must be molded with "SEALED BEAM" and the appropriate designation code as shown in Table II in characters no less than 6.35 mm in size.

S6.5.3.3.2 The face of any character molded on the surface of the lens must not be raised more than 0.5 mm above the lens surface.

S6.5.3.3.3 Type 1C1, 2C1, and 2D1 headlamps must have no raised markings on the outside surface of the lens between the diameters of 40 mm and 90 mm about the lens center.

S6.5.3.3.4 Type 1A1, 2A1, 2B1, and 2E1 headlamps must have no raised markings on the outside surface of the lens within a diameter of 70 mm about the lens center.

S6.5.3.3.5 Type LF, UF, 1G1, 2G1, and 2H1 headlamps must have no raised markings on the outside surface of the lens within a diameter of 35 mm about the lens center.

S6.5.3.3.6 A Type 1C1 replacement headlamp may be marked "1" rather than "1C1". A Type 2C1 replacement headlamp may be marked "2" rather than "2C1". A Type 2D1 replacement headlamp may be marked "TOP" or "2" rather than "2D1".

S6.5.3.4 Replaceable bulb headlamp markings.

S6.5.3.4.1 The lens of each replaceable bulb headlamp must bear permanent marking in front of each replaceable light source with which it is equipped that states either: The HB Type, if the light source conforms to S11 of this standard for filament light sources, or the bulb marking/designation provided in compliance with Section VIII of Appendix A of 49 CFR Part 564 (if the light source conforms to S11 of this standard for discharge light sources).

S6.5.3.4.1.1 No marking need be provided if the only replaceable light source in the headlamp is type HB1.

S6.5.3.5 Additional headlamp markings. Additional marking requirements for headlamps are found in, S10.14.4, S10.15.4, S10.17.2, S10.18.5, S10.18.7, and S10.18.9 of this standard.

S6.6 Associated equipment.

S6.6.1 All vehicles to which this standard applies, except trailers, must be equipped with a turn signal operating unit, a turn signal flasher, a turn signal

indicator, a headlamp beam switching device, and an upper beam headlamp indicator meeting the requirements of S9.

S6.6.2 All vehicles to which this standard applies except trailers and motorcycles must be equipped with a vehicular hazard warning operating unit, a vehicular hazard warning signal flasher, and a vehicular hazard warning signal pilot indicator meeting the requirements of S9.

S6.6.3 License plate holder. Each rear license plate holder must be designed and constructed to provide a substantial plane surface on which to mount the plate. The plane of the license plate mounting surface and the plane on which the vehicle stands must be perpendicular within $\pm 15^\circ$.

S6.7 Replacement equipment.

S6.7.1 General.

S6.7.1.1 Each replacement lamp, reflective device, or item of associated equipment, including a combination lamp, must:

(a) Be designed to conform to meet all requirements specified in this standard for that type of lamp, reflective device, or other item of equipment (in the case of a combination lamp, it must meet these requirements for each function); and

(b) Include all of the functions of the lamp, reflective device, or item of associated equipment, including a combination lamp, it is designed to replace or is capable of replacing (other than functions not required by this standard).

S6.7.1.2 Each replacement lamp, reflective device, or item of associated equipment, including a combination lamp, which is designed or recommended for particular vehicle models must be designed so that it does not take the vehicle out of compliance with this standard when the individual device is installed on the vehicle. Except as provided in S6.7.1.3, the determination of whether a vehicle would be taken out of compliance with this standard when an individual device is installed on the vehicle is made without regard to whether additional devices, including separate lamps or reflective devices sold together with the device, would also be installed.

S6.7.1.3 In the case of a lamp or other device that is used on each side of the vehicle in pairs, the determination (for the purposes of S6.7.1.2) of whether a vehicle would be taken out of compliance with this standard when an individual device is installed on the vehicle is made assuming that the other matched paired device would be installed on the other side of the vehicle, whether or not the

matched paired devices are sold together. This provision does not limit the responsibilities of manufacturers, distributors, dealers or motor vehicle repair businesses under 49 U.S.C. 30122, *Making safety devices and elements inoperative.*

S6.7.2 Version of this standard. The requirements of S6.7.1 must be met, at the option of the manufacturer, using either the current version of this standard or the standard in effect at the time of manufacture of the original equipment being replaced.

S7 Signal lamp requirements.

S7.1 Turn signal lamps.

S7.1.1 Front turn signal lamps.

S7.1.1.1 Number. See Tables I-a and I-c.

S7.1.1.2 Color of light. See Tables I-a and I-c.

S7.1.1.3 Mounting location. See Tables I-a and I-c.

S7.1.1.4 Mounting height. See Tables I-a and I-c.

S7.1.1.5 Activation. See Tables I-a and I-c.

S7.1.1.6 Effective projected luminous lens area. See Table IV-a.

S7.1.1.7 Visibility. See S6.4.

S7.1.1.8 Indicator. See S9.3.

S7.1.1.9 Markings. See S6.5.

S7.1.1.10 Spacing to other lamps.

S7.1.1.10.1 Each front turn signal lamp must also be designed to comply with any additional photometry requirements based on its installed spacing to other lamps as specified by this section. Where more than one spacing relationship exists for a turn signal lamp the requirement must be the one that specifies the highest luminous intensity multiplier of Tables VI-a and VI-b.

S7.1.1.10.2 Spacing measurement for non-reflector lamps. For any front turn signal lamp that does not employ a reflector to meet photometric requirements, the spacing must be measured from the light source of the turn signal lamp to the lighted edge of any lower beam headlamp, or any lamp such as an auxiliary lower beam headlamp or fog lamp used to supplement the lower beam headlamp.

S7.1.1.10.3 Spacing measurement for lamps with reflectors. For any front turn signal lamp which employs a reflector, such as a parabolic reflector, to meet photometric requirements, the spacing must be measured from the geometric centroid of the turn signal lamp effective projected luminous lens area to the lighted edge of any lower beam headlamp, or any lamp such as an auxiliary lower beam headlamp or fog lamp used to supplement the lower beam headlamp.

S7.1.1.10.4 Spacing based photometric multipliers.

(a) where the spacing measurement of S7.1.1.10.2 or S7.1.1.10.3 between a turn signal lamp and the lighted edge of any lower beam headlamp is less than 100 mm the photometric multiplier must be 2.5.

(b) where the spacing measurement of S7.1.1.10.2 or S7.1.1.10.3 between a turn signal lamp and the lighted edge of any lamp such as an auxiliary lower beam headlamp or fog lamp used to supplement the lower beam headlamp is at least 75 mm but less than 100 mm the photometric multiplier of Table VI must be 1.5.

(c) where the spacing measurement of S7.1.1.10.2 or S7.1.1.10.3 between a turn signal lamp and the lighted edge of any lamp such as an auxiliary lower beam headlamp or fog lamp used to supplement the lower beam headlamp is at least 60 mm but less than 75 mm the photometric multiplier must be 2.0.

(d) where the spacing measurement of S7.1.1.10.2 or S7.1.1.10.3 between a turn signal lamp and the lighted edge of any lamp such as an auxiliary lower beam headlamp or fog lamp used to supplement the lower beam headlamp is less than 60 mm the photometric multiplier must be 2.5.

S7.1.1.11 Multiple compartments and multiple lamps.

S7.1.1.11.1 A multiple compartment lamp or multiple lamps may be used to meet the photometric requirements of a front turn signal lamp.

S7.1.1.11.2 If a multiple compartment lamp or multiple lamps are used on a passenger car or on a multipurpose passenger vehicle, truck, bus, or trailer of less than 2032 mm in overall width, and the distance between adjacent light sources does not exceed 560 mm for two compartment or lamp arrangements and does not exceed 410 mm for three compartments or lamp arrangements, then the combination of the compartments or lamps must be used to meet the photometric requirements for the corresponding number of lighted sections specified in Tables VI-a or VI-b.

S7.1.1.11.3 If the distance between adjacent light sources exceeds the previously stated dimensions, each compartment or lamp must comply with the photometric requirements for one lighted section specified in Tables VI-a or VI-b.

S7.1.1.11.4 *Lamps installed on vehicles 2032 mm or more in overall width.* Multiple compartment front turn signal lamps installed on multipurpose passenger vehicles, trucks, and buses 2032 mm or more in overall width require measurement of the photometrics for the entire lamp and not for individual compartments.

S7.1.1.12 Ratio to parking lamps and clearance lamps.

S7.1.1.12.1 When a parking lamp, or a clearance lamp on a multipurpose passenger vehicle, truck, trailer, or bus of 2032 mm or more in overall width, is combined with a front turn signal lamp, the luminous intensity of the front turn signal lamp at each identified test point must not be less than the luminous intensity of the parking lamp or clearance lamp at that same test point times the multiplier shown for that test point in Tables VI-a or VI-b.

S7.1.1.12.2 If a multiple compartment or multiple lamp arrangement is used on a passenger car or on a multipurpose passenger vehicle, truck, bus, or trailer of less than 2032 mm in overall width, and the distance between the optical axes for both the parking lamp and turn signal lamp is within 560 mm for two compartment or lamp arrangements or 410 mm for three compartment or lamp arrangements, then the ratio must be computed with all compartments or lamps lighted.

S7.1.1.12.3 If a multiple compartment or multiple lamp arrangement is used and the distance between optical axes for one of the functions exceeds 560 mm for two compartment or lamp arrangements or 410 mm for three compartments or lamp arrangements, then the ratio must be computed for only those compartments or lamps where the parking lamp and turn signal lamp are optically combined.

S7.1.1.12.4 Where the clearance lamp is combined with the turn signal lamp, and the maximum luminous intensity of the clearance lamp is located below horizontal and within an area generated by a 1.0 radius around a test point, the ratio for the test point may be computed using the lowest value of the clearance lamp luminous intensity within the generated area.

S7.1.1.13 Photometry.

S7.1.1.13.1 When tested according to the procedure of S14.2.1, each front turn signal lamp must be designed to conform to the base photometry requirements plus any applicable multipliers as shown in Tables VI-a and VI-b for the number of lamp compartments or individual lamps and the type of vehicle it is installed on.

S7.1.1.13.2 As an alternative to S7.1.1.13.1, a front turn signal lamp installed on a motorcycle may be designed to conform to the photometry requirements of Table XIII-a when tested according to the procedure of S14.2.1.

S7.1.1.14 *Physical tests.* Each front turn signal lamp must be designed to conform to the performance requirements of the vibration test,

moisture test, dust test, and corrosion test of S14.5, and the color test and plastic optical material test of S14.4.

S7.1.2 Rear turn signal lamps.

S7.1.2.1 *Number.* See Tables I-a, I-b, and I-c.

S7.1.2.2 *Color of light.* See Tables I-a, I-b, and I-c.

S7.1.2.3 *Mounting location.* See Tables I-a, I-b, and I-c and S6.1.3.2.

S7.1.2.4 *Mounting height.* See Tables I-a, I-b, and I-c.

S7.1.2.5 *Activation.* See Tables I-a, I-b, and I-c.

S7.1.2.6 *Effective projected luminous lens area.* See Table IV-a.

S7.1.2.7 *Visibility.* See S6.4.

S7.1.2.8 *Indicator.* See S9.3.

S7.1.2.9 *Markings.* See S6.5.

S7.1.2.10 *Spacing to other lamps.* No requirement.

S7.1.2.11 *Multiple compartments and multiple lamps.*

S7.1.2.11.1 A multiple compartment lamp or multiple lamps may be used to meet the photometric requirements of a rear turn signal lamp provided the requirements of S6.1.3.2 are met.

S7.1.2.11.2 If a multiple compartment lamp or multiple lamps are used on a passenger car or on a multipurpose passenger vehicle, truck, bus, or trailer of less than 2032 mm in overall width, and the distance between adjacent light sources does not exceed 560 mm for two compartment or lamp arrangements and does not exceed 410 mm for three compartment or lamp arrangements, then the combination of the compartments or lamps must be used to meet the photometric requirements for the corresponding number of lighted sections specified in Table VII.

S7.1.2.11.3 If the distance between adjacent light sources exceeds the previously stated dimensions, each compartment or lamp must comply with the photometric requirements for one lighted section specified in Table VII.

S7.1.2.11.4 *Lamps installed on vehicles 2032 mm or more in overall width.* Multiple compartment rear turn signal lamps installed on multipurpose passenger vehicles, trucks, and buses 2032 mm or more in overall width require measurement of the photometrics for the entire lamp and not for individual compartments.

S7.1.2.12 Ratio to taillamps and clearance lamps.

S7.1.2.12.1 When a taillamp, or a clearance lamp on a multipurpose passenger vehicle, truck, trailer, or bus of 2032 mm or more in overall width, is combined with a rear turn signal lamp, the luminous intensity of the rear turn signal lamp at each identified test point must not be less than the

luminous intensity of the taillamp or clearance lamp at that same test point times the multiplier shown for that test point in Table VII.

S7.1.2.12.2 If a multiple compartment or multiple lamp arrangement is used on a passenger car or on a multipurpose passenger vehicle, truck, bus, or trailer of less than 2032 mm in overall width, and the distance between the optical axes for both the taillamp and turn signal lamp is within 560 mm for two compartment or lamp arrangement or 410 mm for three compartments or lamp arrangements, then the ratio must be computed with all compartments or lamps lighted.

S7.1.2.12.3 If a multiple compartment or multiple lamp arrangement is used and the distance between optical axes for one of the functions exceeds 560 mm for two compartment or lamp arrangements or 410 mm for three compartment or lamp arrangements, then the ratio must be computed for only those compartments or lamps where the taillamp and turn signal lamp are optically combined.

S7.1.2.12.4 Where the taillamp or clearance lamp is combined with the turn signal lamp, and the maximum luminous intensity of the taillamp or clearance lamp is located below horizontal and within an area generated by a 0.5° radius around a test point for a taillamp on a passenger car or on a multipurpose passenger vehicle, truck, bus, or trailer of less than 2032 mm in overall width, or by a 1.0° radius around a test point for a taillamp or clearance lamp on a vehicle 2032 mm or more in overall width, the ratio for the test point may be computed using the lowest value of the taillamp or clearance lamp luminous intensity within the generated area.

S7.1.2.13 *Photometry.*

S7.1.2.13.1 Each rear turn signal lamp must be designed to conform to the photometry requirements of Table VII, when tested according to the procedure of S14.2.1, for the number of lamp compartments or individual lamps, the type of vehicle it is installed on, and the lamp color as specified by this section.

S7.1.2.13.2 As an alternative to S7.1.2.13.1, a rear turn signal lamp installed on a motorcycle may be designed to conform to the photometry requirements of Table XIII-a when tested according to the procedure of S14.2.1.

S7.1.2.14 *Physical tests.* Each rear turn signal lamp must be designed to conform to the performance requirements of the vibration test, moisture test, dust test, and corrosion

test of S14.5, and the color test and plastic optical material test of S14.4.

S7.1.3 *Combined lamp bulb indexing.*

S7.1.3.1 Each turn signal lamp optically combined with a taillamp or a parking lamp, or clearance lamp where installed on a vehicle 2032 mm or more in overall width, where a two-filament bulb is used must have a bulb with an indexing base and a socket designed so that bulbs with non-indexing bases cannot be used.

S7.1.3.2 Removable sockets must have an indexing feature so that they cannot be re-inserted into lamp housings in random positions, unless the lamp will perform its intended function with random light source orientation.

S7.2 *Taillamps.*

S7.2.1 *Number.* See Tables I-a, I-b, and I-c.

S7.2.2 *Color of light.* See Tables I-a, I-b, and I-c.

S7.2.3 *Mounting location.* See Tables I-a, I-b, and I-c and S6.1.3.2.

S7.2.4 *Mounting height.* See Tables I-a, I-b, and I-c.

S7.2.5 *Activation.* See Tables I-a, I-b, and I-c.

S7.2.6 *Effective projected luminous lens area.* No requirement.

S7.2.7 *Visibility.* See S6.4.

S7.2.8 *Indicator.* No requirement.

S7.2.9 *Markings.* See S6.5.

S7.2.10 *Spacing to other lamps.* No requirement.

S7.2.11 *Multiple compartments and multiple lamps.*

S7.2.11.1 A multiple compartment lamp or multiple lamps may be used to meet the photometric requirements of a taillamp provided the requirements of S6.1.3.2 are met.

S7.2.11.2 If a multiple compartment lamp or multiple lamps are used and the distance between the optical axes does not exceed 560 mm for two compartment or lamp arrangements and does not exceed 410 mm for three compartment or lamp arrangements, then the combination of the compartments or lamps must be used to meet the photometric requirements for the corresponding number of lighted sections specified in Table VIII.

S7.2.11.3 If the distance between optical axes exceeds the previously stated dimensions, each compartment or lamp must comply with the photometric requirements for one lighted section specified in Table VIII.

S7.2.11.4 *Taillamps installed on vehicles 2032 mm or more in overall width.* A maximum of two taillamps and/or two compartments per side may be mounted closer together than 560 mm providing that each compartment

and/or lamp meets the single lighted section photometric requirements specified in Table VIII. Each lamp and/or compartment utilized in this manner must meet the single lighted section requirements for all functions for which it is designed.

S7.2.12 *Ratio.* See S7.1.2.12 for rear turn signal lamps and S7.3.12 for stop lamps.

S7.2.13 *Photometry.* Each taillamp must be designed to conform to the photometry requirements of Table VIII, when tested according to the procedure of S14.2.1, for the number of lamp compartments or individual lamps and the type of vehicle it is installed on.

S7.2.14 *Physical tests.* Each taillamp must be designed to conform to the performance requirements of the vibration test, moisture test, dust test, and corrosion test of S14.5, and the color test and plastic optical material test of S14.4.

S7.3 *Stop lamps.*

S7.3.1 *Number.* See Tables I-a, I-b, and I-c.

S7.3.2 *Color of light.* See Tables I-a, I-b, and I-c.

S7.3.3 *Mounting location.* See Tables I-a, I-b, and I-c and S6.1.3.2.

S7.3.4 *Mounting height.* See Tables I-a, I-b, and I-c.

S7.3.5 *Activation.* See Tables I-a, I-b, and I-c.

S7.3.6 *Effective projected luminous lens area.* See Table IV-a.

S7.3.7 *Visibility.* See S6.4.

S7.3.8 *Indicator.* No requirement.

S7.3.9 *Markings.* See S6.5.

S7.3.10 *Spacing to other lamps.* No requirement.

S7.3.11 *Multiple compartments and multiple lamps.*

S7.3.11.1 A multiple compartment lamp or multiple lamps may be used to meet the photometric requirements of a stop lamp provided the requirements of S6.1.3.2 are met.

S7.3.11.2 If a multiple compartment lamp or multiple lamps are used on a passenger car or on a multipurpose passenger vehicle, truck, bus, or trailer of less than 2032 mm in overall width, and the distance between adjacent light sources does not exceed 560 mm for two compartment or lamp arrangements and does not exceed 410 mm for three compartment or lamp arrangements, then the combination of the compartments or lamps must be used to meet the photometric requirements for the corresponding number of lighted sections specified in Table IX.

S7.3.11.3 If the distance between adjacent light sources exceeds the previously stated dimensions, each compartment or lamp must comply with the photometric requirements for one lighted section specified in Table IX.

S7.3.11.4 *Lamps installed on vehicles 2032 mm or more in overall width.* Multiple compartment stop lamps installed on multipurpose passenger vehicles, trucks, and buses 2032 mm or more in overall width require measurement of the photometrics for the entire lamp and not for individual compartments.

S7.3.12 *Ratio to taillamps.*

S7.3.12.1 When a taillamp is combined with a stop lamp, the luminous intensity of the stop lamp at each identified test point must not be less than the luminous intensity of the taillamp at that same test point times the multiplier shown for that test point in Table IX.

S7.3.12.2 If a multiple compartment or multiple lamp arrangement is used on a passenger car or on a multipurpose passenger vehicle, truck, bus, or trailer of less than 2032 mm in overall width, and the distance between the optical axes for both the taillamp and stop lamp is within 560 mm for two compartment or lamp arrangements or 410 mm for three compartment or lamp arrangements, then the ratio must be computed with all compartments or lamps lighted.

S7.3.12.3 If a multiple compartment or multiple lamp arrangement is used and the distance between optical axes for one of the functions exceeds 560 mm for two compartment or lamp arrangements or 410 mm for three compartments or lamp arrangements, then the ratio must be computed for only those compartments or lamps where the taillamp and stop lamp are optically combined.

S7.3.12.4 Where the taillamp is combined with the stop lamp, and the maximum luminous intensity of the taillamp is located below horizontal and within an area generated by a 0.5° radius around a test point for a taillamp on a passenger car or on a multipurpose passenger vehicle, truck, bus, or trailer of less than 2032 mm in overall width, or by a 1.0° radius around a test point for a taillamp on a vehicle 2032 mm or more in overall width, the ratio for the test point may be computed using the lowest value of the taillamp luminous intensity within the generated area.

S7.3.13 *Photometry.*

S7.3.13.1 Each stop lamp must be designed to conform to the photometry requirements of Table IX, when tested according to the procedure of S14.2.1, for the number of lamp compartments or individual lamps and the type of vehicle it is installed on.

S7.3.13.2 A stop lamp installed on a motor driven cycle may be designed to conform to the photometry requirements

of Table XIII-b when tested according to the procedure of S14.2.1.

S7.3.14 *Physical tests.* Each stop lamp must be designed to conform to the performance requirements of the vibration test, moisture test, dust test, and corrosion test of S14.5, and the color test and plastic optical material test of S14.4.

S7.3.15 *Combined lamp bulb indexing.*

S7.3.15.1 Each stop lamp optically combined with a taillamp where a two-filament bulb is used must have a bulb with an indexing base and a socket designed so that bulbs with non-indexing bases cannot be used.

S7.3.15.2 Removable sockets must have an indexing feature so that they cannot be re-inserted into lamp housings in random positions, unless the lamp will perform its intended function with random light source orientation.

S7.4 *Side marker lamps.*

S7.4.1 *Number.* See Tables I-a, I-b, and I-c.

S7.4.2 *Color of light.* See Tables I-a, I-b, and I-c.

S7.4.3 *Mounting location.* See Tables I-a, I-b, and I-c.

S7.4.4 *Mounting height.* See Tables I-a, I-b, and I-c.

S7.4.5 *Activation.* See Tables I-a, I-b, and I-c.

S7.4.6 *Effective projected luminous lens area.* No requirement.

S7.4.7 *Visibility.* No requirement.

S7.4.8 *Indicator.* No requirement.

S7.4.9 *Markings.* See S6.5.

S7.4.10 *Spacing to other lamps.* No requirement.

S7.4.11 *Multiple compartments and multiple lamps.* No requirement.

S7.4.12 *Ratio.* No requirement.

S7.4.13 *Photometry.*

S7.4.13.1 Each side marker lamp must be designed to conform to the photometry requirements of Table X, when tested according to the procedure of S14.2.1, for the lamp color as specified by this section.

S7.4.13.2 *Inboard photometry.* For each motor vehicle less than 30 feet in overall length and less than 2032 mm in overall width, the minimum photometric intensity requirements for a side marker lamp may be met for all inboard test points at a distance of 15 feet from the vehicle and on a vertical plane that is perpendicular to the longitudinal axis of the vehicle and located midway between the front and rear side marker lamps.

S7.4.14 *Physical tests.* Each side marker lamp must be designed to conform to the performance requirements of the vibration test, moisture test, dust test, and corrosion

test of S14.5, and the color test and plastic optical material test of S14.4.

S7.5 *Clearance and identification lamps.*

S7.5.1 *Number.* See Tables I-a and I-b.

S7.5.2 *Color of light.* See Tables I-a and I-b.

S7.5.3 *Mounting location.* See Tables I-a and I-b.

S7.5.4 *Mounting height.* See Tables I-a and I-b.

S7.5.5 *Activation.* See Tables I-a and I-b.

S7.5.6 *Effective projected luminous lens area.* No requirement.

S7.5.7 *Visibility.* No requirement.

S7.5.8 *Indicator.* No requirement.

S7.5.9 *Markings.* See S6.5.

S7.5.10 *Spacing to other lamps.* No requirement.

S7.5.11 *Multiple compartments and multiple lamps.* No requirement.

S7.5.12 *Ratio.*

S7.5.12.1 *Clearance lamps.* See S7.1.1.12 for front turn signal lamps and S7.1.2.12 for rear turn signal lamps.

S7.5.12.2 *Identification lamps.* No requirement.

S7.5.13 *Photometry.* Each clearance or identification lamp must be designed to conform to the photometry requirements of Table XI, for the applicable lamp color, when tested according to the procedure of S14.2.1.

S7.5.14 *Physical tests.* Each clearance and identification lamp must be designed to conform to the performance requirements of the vibration test, moisture test, dust test, and corrosion test of S14.5, and the color test and plastic optical material test of S14.4.

S7.6 *Backup lamps.*

S7.6.1 *Number.* See Table I-a and S6.1.1.

S7.6.2 *Color of light.*

S7.6.2.1 See Table I-a.

S7.6.2.2 A backup lamp may project incidental red, yellow, or white light through reflectors or lenses that are adjacent, close to, or a part of the lamp assembly.

S7.6.3 *Mounting location.* See Table I-a.

S7.6.4 *Mounting height.* No requirement.

S7.6.5 *Activation.* See Table I-a.

S7.6.6 *Effective projected luminous lens area.* No requirement.

S7.6.7 *Visibility.* See Table V-a.

S7.6.8 *Indicator.* No requirement.

S7.6.9 *Markings.* See S6.5.

S7.6.10 *Spacing to other lamps.* No requirement.

S7.6.11 *Multiple compartments and multiple lamps.* No requirement.

S7.6.12 *Ratio.* No requirement.

S7.6.13 *Photometry.* Each backup lamp must be designed to conform to

the photometry requirements of Table XII, when tested according to the procedure of S14.2.1, as specified by this section.

S7.6.14 *Physical tests.* Each backup lamp must be designed to conform to the performance requirements of the vibration test, moisture test, dust test, and corrosion test of S14.5, and the color test and plastic optical material test of S14.4.

S7.7 *License plate lamps.*

S7.7.1 *Number.* See Tables I-a, I-b, and I-c and S6.1.1.

S7.7.2 *Color of light.* See Tables I-a, I-b, and I-c.

S7.7.3 *Mounting location.* See Tables I-a, I-b, and I-c.

S7.7.4 *Mounting height.* See Tables I-a, I-b, and I-c.

S7.7.5 *Activation.* See Tables I-a, I-b, and I-c.

S7.7.6 *Effective projected luminous lens area.* No requirement.

S7.7.7 *Visibility.* No requirement.

S7.7.8 *Indicator.* No requirement.

S7.7.9 *Markings.* See S6.5.

S7.7.10 *Spacing to other lamps.* No requirement.

S7.7.11 *Multiple compartments and multiple lamps.* No requirement.

S7.7.12 *Ratio.* No requirement.

S7.7.13 *Photometry.*

S7.7.13.1 Each license plate lamp must be designed to conform to the photometry requirements of this section when tested according to the procedure of S14.2.2.

S7.7.13.2 An illumination value of no less than 8 lx [0.75 fc] must be met at each test station target location shown in Figure 19.

S7.7.13.3 The ratio of the average of the two highest illumination values divided by the average of the two lowest illumination values must not exceed 20:1 for vehicles other than motorcycles and motor driven cycles.

S7.7.13.4 The ratio of the highest illumination value divided by the average of the two lowest illumination values must not exceed 15:1 for motorcycles and motor driven cycles.

S7.7.14 *Physical tests.* Each license plate lamp must be designed to conform to the performance requirements of the vibration test, moisture test, dust test, and corrosion test of S14.5, and the color test and plastic optical material test of S14.4.

S7.7.15 *Installation.*

S7.7.15.1 Each license plate lamp installed on a vehicle other than a motorcycle or motor driven cycle must be of such size and design as to provide illumination on all parts of a 150 mm by 300 mm test plate.

S7.7.15.2 Each license plate lamp installed on a motorcycle or motor

driven cycle must be of such size and design as to provide illumination on all parts of a 100 mm by 175 mm test plate.

S7.7.15.3 The light rays must reach all portions of an imaginary plate of the same size at least 25 mm ahead of the actual plate measured perpendicular to the plane of the plate.

S7.7.15.4 *Incident light from single lamp.* When a single lamp as shown in Figure 20 is used to illuminate the license plate, the lamp and license plate holder must bear such relation to each other that at no point on the plate must the incident light make an angle of less than 8° to the plane of the plate, this angle being measured from the edge of the light emitting surface of the lamp farthest from the surface of the plate.

S7.7.15.5 *Incident light from multiple lamps.* When two or more lamps as shown in Figure 20 are used to illuminate the license plate, the minimum 8° incident light angle must apply only to that portion of the plate which the particular lamp is designed to illuminate. The angle must be measured in the same manner as S7.7.15.4.

S7.8 *Parking lamps.*

S7.8.1 *Number.* See Table I-a.

S7.8.2 *Color of light.* See Table I-a.

S7.8.3 *Mounting location.* See Table I-a.

S7.8.4 *Mounting height.* See Table I-a.

S7.8.5 *Activation.* See Table I-a.

S7.8.6 *Effective projected luminous lens area.* No requirement.

S7.8.7 *Visibility.* See S6.4.

S7.8.8 *Indicator.* No requirement.

S7.8.9 *Markings.* See S6.5.

S7.8.10 *Spacing to other lamps.* No requirement.

S7.8.11 *Multiple compartments and multiple lamps.* No requirement.

S7.8.12 *Ratio.* See S7.1.1.12 for front turn signal lamps.

S7.8.13 *Photometry.* Each parking lamp must be designed to conform to the photometry requirements of Table XIV, when tested according to the procedure of S14.2.1, as specified by this section.

S7.8.14 *Physical tests.* Each parking lamp must be designed to conform to the performance requirements of the vibration test, moisture test, dust test, and corrosion test of S14.5, and the color test and plastic optical material test of S14.4.

S7.9 *High-mounted stop lamps.*

S7.9.1 *Number.* See Table I-a and S6.1.1.2.

S7.9.2 *Color of light.* See Table I-a.

S7.9.3 *Mounting location.* See Table I-a.

S7.9.4 *Mounting height.* See Table I-a and S6.1.4.1.

S7.9.5 *Activation.* See Table I-a.

S7.9.6 *Effective projected luminous lens area.* See Table IV-b.

S7.9.7 *Visibility.* See Table V-a.

S7.9.8 *Indicator.* No requirement.

S7.9.9 *Markings.* See S6.5.

S7.9.10 *Spacing to other lamps.* No requirement.

S7.9.11 *Multiple compartments and multiple lamps.* No requirement.

S7.9.12 *Ratio.* No requirement.

S7.9.13 *Photometry.* Each high-mounted stop lamp must be designed to conform to the photometry requirements of Table XV, when tested according to the procedure of S14.2.1, as specified by this section.

S7.9.14 *Physical tests.*

S7.9.14.1 Each high-mounted stop lamp must be designed to conform to the performance requirements of the vibration test of S14.5, and the color test and plastic optical material test of S14.4.

S7.9.14.2 Each high-mounted stop lamp that is not mounted inside the vehicle must be designed to conform to the performance requirements of the moisture test, dust test, and corrosion test of S14.5.

S7.10 *Daytime running lamps (DRLs).*

S7.10.1 *Number.* See Table I-a.

S7.10.2 *Color of light.* See Table I-a.

S7.10.3 *Mounting location.* See Table I-a.

S7.10.4 *Mounting height.* See Table I-a and S7.10.13(b).

S7.10.5 *Activation.* See Table I-a and S7.10.10.1(c).

S7.10.6 *Effective projected luminous lens area.* No requirement.

S7.10.7 *Visibility.* No requirement.

S7.10.8 *Indicator.* No requirement.

S7.10.9 *Markings.* See S6.5.

S7.10.10 *Spacing to other lamps.*

S7.10.10.1 *Spacing to turn signal lamps.* Each DRL not optically combined with a turn signal lamp must be located on the vehicle so that the distance from its lighted edge to the optical center of the nearest turn signal lamp is not less than 100 mm unless,

(a) The luminous intensity of the DRL is not more than 2,600 cd at any location in the beam and the turn signal lamp meets 2.5 times the base front turn signal photometric requirements, or

(b) The DRL is optically combined with a lower beam headlamp and the turn signal lamp meets 2.5 times the base front turn signal photometric requirements, or

(c) The DRL is deactivated when the turn signal or hazard warning signal lamp is activated.

S7.10.11 *Multiple compartments and multiple lamps.* No requirement.

S7.10.12 *Ratio.* No requirement.

S7.10.13 *Photometry.* Each DRL must have a luminous intensity not less

than 500 cd at test point H–V, nor more than 3,000 cd at any location in the beam when tested according to the procedure of S14.2.4 as specified by this section, unless it is:

(a) A lower beam headlamp intended to operate as a DRL at full voltage, or a voltage lower than used to operate it as a lower beam headlamp, or

(b) An upper beam headlamp intended to operate as a DRL, whose luminous intensity at test point H–V is not more than 7,000 cd, and whose mounting height is not higher than 864 mm.

S7.10.14 *Physical tests.* Each DRL that is not combined with another required lamp must be designed to conform to the performance requirements of the color test and plastic optical material test of S14.4.

S7.11 *School bus signal lamps.*

S7.11.1 *Number.* See Table I–a.

S7.11.2 *Color of light.* See Table I–a.

S7.11.3 *Mounting location.* See

Table I–a.

S7.11.4 *Mounting height.* See Table

I–a.

S7.11.5 *Activation.* See Table I–a.

S7.11.6 *Effective projected luminous lens area.* See Table IV–c.

S7.11.7 *Visibility.* See Table V–a.

S7.11.8 *Indicator.* No requirement.

S7.11.9 *Markings.* See S6.5.

S7.11.10 *Spacing to other lamps.* No requirement.

S7.11.11 *Multiple compartments and multiple lamps.* No requirement.

S7.11.12 *Ratio.* No requirement.

S7.11.13 *Photometry.* Each school bus signal lamp must be designed to conform to the photometry requirements of Table XVII, when tested according to the procedure of S14.2.1, for the lamp color as specified by this section.

S7.11.14 *Physical tests.* Each school bus signal lamp must be designed to conform to the performance requirements of the vibration test, moisture test, dust test, and corrosion test of S14.5, and the color test and plastic optical material test of S14.4.

S8 *Reflective device requirements.*

S8.1 *Reflex reflectors.*

S8.1.1 *Number.* See Tables I–a, I–b, and I–c.

S8.1.2 *Color.* See Tables I–a, I–b, and I–c.

S8.1.3 *Mounting location.* See Tables I–a, I–b, and I–c.

S8.1.4 *Mounting height.* See Tables I–a, I–b, and I–c.

S8.1.5 *Activation.* No requirement.

S8.1.6 *Effective projected luminous lens area.* No requirement.

S8.1.7 *Visibility.* No requirement.

S8.1.8 *Indicator.* No requirement.

S8.1.9 *Markings.* See S6.5.

S8.1.10 *Spacing to other lamps or reflective devices.* No requirement.

S8.1.11 *Photometry.* Each reflex reflector must be designed to conform to the photometry requirements of Table XVI–a when tested according to the procedure of S14.2.3 for the reflex reflector color as specified by this section.

S8.1.12 *Physical tests.* Each reflex reflector must be designed to conform to the performance requirements of the vibration test, moisture test, dust test, and corrosion test of S14.5, and the color test and plastic optical material test of S14.4.

S8.1.13 *Alternative side reflex reflector material.* Reflective material conforming to Federal Specification L–S–300, Sheeting and Tape, Reflective; Non-exposed Lens, Adhesive Backing, (September 7, 1965) (incorporated by reference, see 571.108 S5.2 of this title), may be used for side reflex reflectors if this material as used on the vehicle, meets the performance requirements of Table XVI–a.

S8.2 *Conspicuity systems.* The requirement for conspicuity systems may be met with retroreflective sheeting, conspicuity reflex reflectors, or a combination of retroreflective sheeting and conspicuity reflex reflectors.

S8.2.1 *Retroreflective sheeting.*

S8.2.1.1 *Retroreflective sheeting* must consist of a smooth, flat, transparent exterior film with retroreflective elements embedded or suspended beneath the film so as to form a non-exposed retroreflective optical system.

S8.2.1.2 *Retroreflective sheeting material.* Retroreflective sheeting must meet the requirements, except photometry, of ASTM D 4956–90, Standard for Retroreflective Sheeting for Traffic Control, (incorporated by reference, see 571.108 S5.2 of this title) for Type V Sheeting. Sheeting of Grade DOT–C2 of no less than 50 mm wide, Grade DOT–C3 of no less than 75 mm wide, or Grade DOT–C4 of no less than 100 mm wide may be used.

S8.2.1.3 *Certification marking.* The letters DOT–C2, DOT–C3, or DOT–C4, as appropriate, constituting a certification that the retroreflective sheeting conforms to the requirements of this standard, must appear at least once on the exposed surface of each white or red segment of retroreflective sheeting, and at least once every 300 mm on retroreflective sheeting that is white only. The characters must be not less than 3 mm high, and must be permanently stamped, etched, molded, or printed in indelible ink.

S8.2.1.4 *Application pattern.*

S8.2.1.4.1 *Alternating red and white materials.*

S8.2.1.4.1.1 As shown in Figures 12–1 and 12–2, where alternating material is installed, except for a segment that is trimmed to clear obstructions, or lengthened to provide red sheeting near red lamps, alternating material must be installed with each white and red segment having a length of 300 ± 150 mm.

S8.2.1.4.1.2 Neither white nor red sheeting must represent more than two thirds the aggregate of any continuous strip marking the width of a trailer, or any continuous or broken strip marking its length.

S8.2.1.5 *Application location.* Need not be installed, as illustrated in Figure 12–2, on discontinuous surfaces such as outside ribs, stake post pickets on platform trailers, and external protruding beams, or to items of equipment such as door hinges and lamp bodies on trailers and body joints, stiffening beads, drip rails, and rolled surfaces on truck tractors.

S8.2.1.6 *Application spacing.* As illustrated in Figure 12–2, the edge of any white sheeting must not be located closer than 75 mm to the edge of the luminous lens area of any red or amber lamp that is required by this standard. The edge of any red sheeting must not be located closer than 75 mm to the edge of the luminous lens area of any amber lamp that is required by this standard.

S8.2.1.7 *Photometry.* Each retroreflective sheeting must be designed to conform to the photometry requirements of Table XVI–c when tested according to the procedure of S14.2.3 for the color and grade as specified by this section.

S8.2.2 *Conspicuity reflex reflectors.*

S8.2.2.1 *Certification marking.* The exposed surface of each conspicuity reflex reflector must be marked with the letters DOT–C which constitutes a certification that the reflector conforms to the conspicuity reflex reflector requirements of this standard. The certification must be not less than 3 mm high, and must be permanently stamped, etched, molded, or printed in indelible ink.

S8.2.2.2 *Application pattern.*

S8.2.2.2.1 *Alternating red and white materials.* Conspicuity reflex reflectors must be installed in a repetitive pattern of two or three white reflectors alternating with two or three red reflectors, with the center of each reflector not more than 100 mm from the center of each adjacent reflector.

S8.2.2.2.2 *White material.* White conspicuity reflex reflectors must be installed with the center of each reflector not more than 100 mm from the center of each adjacent reflector.

8.2.2.3 *Photometry.*

8.2.2.3.1 Each red conspicuity reflex reflector must be designed to conform to the photometry requirements of Table XVI-a for a red reflex reflector and Table XVI-b for a red conspicuity reflex reflector when tested according to the procedure of S14.2.3 as specified by this section.

8.2.2.3.2 Each white conspicuity reflex reflector installed in only a horizontal orientation must be designed to conform to the photometry requirements of Table XVI-a for a white reflex reflector and Table XVI-b for a white horizontal conspicuity reflex reflector when tested according to the procedure of S14.2.3 as specified by this section.

8.2.2.3.3 Each white conspicuity reflex reflector installed in a vertical orientation must be designed to conform to the photometry requirements of Table XVI-a for a white reflex reflector, and Table XVI-b for a white horizontal conspicuity reflex reflector and a white vertical conspicuity reflex reflector when tested according to the procedure of S14.2.3 as specified by this section.

8.2.3 *Conspicuity system installation on trailers.*

8.2.3.1 *Trailer rear.*

8.2.3.1.1 *Element 1—alternating red and white materials.* As shown in Figure 11, a strip of sheeting or conspicuity reflex reflectors, as horizontal as practicable, must be applied across the full width of the trailer, as close to the extreme edges as practicable, and as close as practicable to not less than 375 mm and not more than 1525 mm above the road surface at the strip centerline with the trailer at curb weight.

8.2.3.1.2 *Element 2—white.* (not required for container chassis or for platform trailers without bulkheads).

8.2.3.1.2.1 As shown in Figure 11, two pairs of strips of sheeting or conspicuity reflex reflectors, each pair consisting of strips 300 mm long of Grade DOT-C2, DOT-C3, or DOT-C4, must be applied horizontally and vertically to the right and left upper contours of the body, as viewed from the rear, as close to the top of the trailer and as far apart as practicable.

8.2.3.1.2.2 If the perimeter of the body, as viewed from the rear, is other than rectangular, the strips may be applied along the perimeter, as close as practicable to the uppermost and outermost areas of the rear of the body on the left and right sides.

8.2.3.1.3 *Element 3—alternating red and white materials.* (not required for trailers without underride protection devices).

8.2.3.1.3.1 As shown in Figure 11, a strip of Grade DOT-C2 sheeting no less than 38 mm wide or reflectors must be applied across the full width of the horizontal member of the rear underride protection device.

8.2.3.2 *Trailer side—alternating red and white materials.*

8.2.3.2.1 As shown in Figure 11, a strip of sheeting or conspicuity reflex reflectors must be applied to each side, as horizontal as practicable, originating and terminating as close to the front and rear as practicable, as close as practicable to not less than 375 mm and not more than 1525 mm above the road surface at the strip centerline at curb weight, except that at the location chosen the strip must not be obscured in whole or in part by other motor vehicle equipment or trailer cargo.

8.2.3.2.2 The strip need not be continuous as long as not less than half the length of the trailer is covered and the spaces are distributed as evenly as practicable.

8.2.3.2.3 If necessary to clear rivet heads or other similar obstructions, Grade DOT-C2 sheeting may be separated into two 25 mm wide strips of the same length and color, separated by a space of not more than 25 mm and used in place of the retroreflective sheeting that would otherwise be applied.

8.2.4 *Conspicuity system installation on truck tractors.*

8.2.4.1 *Element 1—alternating red and white materials.* As shown in Figure 13, two strips of sheeting or conspicuity reflex reflectors, each not less than 600 mm long, located as close as practicable to the edges of the rear fenders, mudflaps, or the mudflap support brackets, must be applied to mark the width of the truck tractor.

8.2.4.1.1 The strips must be mounted as horizontal as practicable, in a vertical plane facing the rear, on the rear fenders, on the mudflap support brackets, on plates attached to the mudflap support brackets, or on the mudflaps.

8.2.4.1.2 Strips on mudflaps must be mounted not lower than 300 mm below the upper horizontal edge of the mudflap. If the vehicle is certified with temporary mudflap support brackets, the strips must be mounted on the mudflaps or on plates transferable to permanent mudflap support brackets.

8.2.4.1.3 For a truck tractor without mudflaps, the strips may be mounted outboard of the frame on brackets behind the rear axle or on brackets ahead of the rear axle and above the top of the rear tires at unladen vehicle height, or they may be mounted directly or indirectly to the back of the cab as

close to the outer edges as practicable, above the top of the tires, and not more than 1525 mm above the road surface at unladen vehicle height.

8.2.4.1.4 If the strips are mounted on the back of the cab, no more than 25% of their cumulative area may be obscured by vehicle equipment as determined in a rear orthogonal view.

8.2.4.2 *Element 2—white.* As shown in Figure 13, two pairs of strips of sheeting or conspicuity reflex reflectors, each pair consisting of strips 300 mm long, must be applied horizontally and vertically as practicable to the right and left upper contours of the cab, as close to the top of the cab and as far apart as practicable.

8.2.4.2.1 No more than 25% of their cumulative area may be obscured by vehicle equipment as determined in a rear orthogonal view.

8.2.4.2.2 If one pair must be relocated to avoid obscuration by vehicle equipment, the other pair may be relocated in order to be mounted symmetrically.

8.2.4.2.3 If the rear window is so large as to occupy all the practicable space, the material may be attached to the edge of the window itself.

S9 *Associated equipment requirements.*

S9.1 *Turn signal operating unit.*

S9.1.1 The turn signal operating unit installed on passenger cars, multipurpose passenger vehicles, trucks, and buses less than 2032 mm in overall width must be self-canceling by steering wheel rotation and capable of cancellation by a manually operated control.

S9.1.2 *Physical tests.* Each turn signal operating unit must be designed to conform to all applicable performance requirements of S14.9.

S9.2 *Turn signal flasher.*

S9.2.1 The means of producing the turn signal pilot indicator signal may be incorporated in the flasher. A means of producing an audible signal may be incorporated in the flasher.

S9.2.2 *Physical tests.* Each turn signal flasher must be designed to conform to all applicable performance requirements of S14.9.

S9.3 *Turn signal pilot indicator.*

S9.3.1 Each vehicle equipped with a turn signal operating unit where any turn signal lamp is not visible to the driver must also have an illuminated pilot indicator to provide a clear and unmistakable indication that the turn signal system is activated.

S9.3.2 The indicator must consist of one or more lights flashing at the same frequency as the turn signal lamps.

S9.3.3 The indicator must function satisfactorily under all test conditions

imposed on the turn signal flasher in S14.9.

S9.3.4 Indicator size and color.

S9.3.4.1 If the indicator is located inside the vehicle it must emit a green colored light and have a minimum area equivalent to a $\frac{3}{16}$ in diameter circle.

S9.3.4.2 If the indicator is located outside of the vehicle it must emit a yellow light and have a minimum projected illuminated area of 0.1 sq in.

S9.3.5 The minimum required illuminated area of the indicator must be visible to any tangent on the 95th eyellipse as defined in SAE J941b, *Motor Vehicle Driver's Eye Range*, February 1969, (incorporated by reference, see 571.108 S5.2 of this title) with the steering wheel turned to a straight ahead driving position and in the design location for an adjustable wheel or column.

S9.3.6 Turn signal lamp failure.

Failure of one or more turn signal lamps such that the minimum photometric performance specified in Tables VI or VII is not being met must be indicated by the turn signal pilot indicator by a "steady on", "steady off", or by a significant change in the flashing rate, except when a variable-load turn signal flasher is used on a multipurpose passenger vehicle, truck, or bus 2032 mm or more in overall width, on a truck that is capable of accommodating a slide in camper, or on any vehicle equipped to tow trailers.

S9.4 Headlamp beam switching device. Each vehicle must have a means of switching between lower and upper beams designed and located so that it may be operated conveniently by a simple movement of the driver's hand or foot. The switch must have no dead point and, except as provided by S6.1.5.2, the lower and upper beams must not be energized simultaneously except momentarily for temporary signaling purposes or during switching between beams.

S9.4.1 Semi-automatic headlamp beam switching device. As an alternative to S9.4, a vehicle may be equipped with a semi-automatic means of switching between lower and upper beams.

S9.4.1.1 Operating instructions. Each semi-automatic headlamp switching device must include operating instructions to permit a driver to operate the device correctly including; how to turn the automatic control on and off, how to adjust the provided sensitivity control, and any other specific instructions applicable to the particular device.

S9.4.1.2 Manual override. The device must include a means convenient to the driver for switching to

the opposite beam from the one provided.

S9.4.1.3 Fail safe operation. A failure of the automatic control portion of the device must not result in the loss of manual operation of both upper and lower beams.

S9.4.1.4 Automatic dimming indicator. There must be a convenient means of informing the driver when the device is controlling the headlamps automatically. The device shall not affect the function of the upper beam indicator light.

S9.4.1.5 Lens accessibility. The device lens must be accessible for cleaning when the device is installed on a vehicle.

S9.4.1.6 Mounting height. The center of the device lens must be mounted no less than 24 in. above the road surface.

S9.4.1.7 Physical tests. Each semi-automatic headlamp beam switching device must be designed to conform to all applicable performance requirements of S14.9.

S9.5 Upper beam headlamp indicator. Each vehicle must have a means for indicating to the driver when the upper beams of the headlighting system are activated.

S9.5.1 Indicator size and location. The upper beam headlamp indicator must have a minimum area equivalent to that of a $\frac{3}{16}$ in diameter circle, and be plainly visible to drivers of all heights under normal driving conditions when headlamps are required.

S9.6 Vehicular hazard warning signal operating unit.

S9.6.1 The unit may be an independent device or it may be combined with the turn signal operating unit. If combined with the turn signal operating unit, the actuating motion of the hazard function must differ from the actuating motion of the turn signal function.

S9.6.2 Operating unit switch. The unit must operate independently of the ignition or equivalent switch. If the actuation of the hazard function requires the operation of more than one switch, a means must be provided for actuating all switches simultaneously by a single driver action.

S9.6.3 Physical tests. Each vehicular hazard warning signal operating unit must be designed to conform to all applicable performance requirements of S14.9.

S9.7 Vehicular hazard warning signal flasher.

S9.7.1 The means of producing the hazard warning signal pilot indicator signal may be incorporated in the flasher. A means of producing an

audible signal may be incorporated in the flasher.

S9.7.2 Physical tests. Each vehicular hazard warning signal flasher must be designed to conform to all applicable performance requirements of S14.9.

S9.8 Vehicular hazard warning signal pilot indicator.

S9.8.1 In vehicles equipped with right hand and left hand turn signal pilot indicators, both pilot indicators and /or a separate pilot indicator must flash simultaneously while the vehicle hazard warning signal operating unit is turned on.

S9.8.2 In vehicles equipped with a single turn signal pilot indicator, a separate vehicular hazard warning signal pilot indicator must flash and the turn signal pilot indicator may flash while the vehicle hazard warning signal operating unit is turned on.

S9.8.3 The indicator must function satisfactorily under all test conditions imposed on the vehicular hazard warning signal flasher in S14.9.

S9.8.4 Indicator size and color. If the vehicular hazard warning signal pilot indicator is not combined with the turn signal pilot indicator, it must emit a red color and have a minimum area equivalent to a 0.5 in diameter circle.

S10 Headlighting system requirements.

S10.1 Vehicle headlighting systems.

S10.1.1 Each passenger car, multipurpose passenger vehicle, truck and bus must be equipped with a headlighting system conforming to the requirements of Table II and this standard.

S10.1.2 Each motorcycle must be equipped with a headlighting system conforming to S10.17 of this standard or one half of any headlighting system of Table II which provides both a full upper beam and full lower beam.

S10.2 Aiming. Each headlamp system installed on a motor vehicle must be aimable in accordance with the requirements of S10.18.

S10.3 Number. See Tables I-a and I-c.

S10.4 Color of light. See Tables I-a and I-c.

S10.5 Mounting location. See Tables I-a and I-c and S6.1.3.5.

S10.6 Mounting height. See Tables I-a and I-c.

S10.7 Activation. See Tables I-a and I-c, Table II, and S6.1.5.

S10.8 Effective projected luminous lens area. No requirement.

S10.9 Visibility. No requirement.

S10.10 Indicator. See S9.5.

S10.11 Markings. See S6.5.

S10.12 Spacing to other lamps. See S6.1.3.5.

S10.13 Sealed beam headlighting systems. All sealed beam headlighting

systems must be of a type designated in Table II-a. Each sealed beam headlamp must be designed to conform to the specifications furnished with respect to it pursuant to Appendix C of part 564 of this chapter and Table II-a of this standard. The dimensions applicable to the design of a specific type are those identified with an "I" for interchangeability specified on the applicable drawing(s) filed in Docket No. NHTSA 98-3397.

S10.13.1 Installation. A sealed beam headlighting system must consist of the correct number of designated headlamp units as specified for the applicable system in Table II-a. The units must have their beams activated as specified in Table II-a. A system must provide in total not more than two upper beams and two lower beams.

S10.13.2 Simultaneous aim. Type F sealed beam headlamps may be mounted on common or parallel seating and aiming planes to permit simultaneous aiming of both headlamps provided that there is no provision for adjustment between the common or parallel aiming and seating planes of the two lamps. When tested with any conforming Type UF and LF headlamps in accordance with S14.2.5, the assembly (consisting of the Type UF and LF headlamps, mounting rings, the aiming/seating rings, and aim adjustment mechanism) must be designed to conform to the applicable photometric requirements.

S10.13.3 Photometry. Each sealed beam headlamp must be designed to conform to the photometry requirements of Table XVIII for upper beam and Table XIX for lower beam as specified in Table II-a for the specific headlamp unit and aiming method, when tested according to the procedure of S14.2.5.

S10.13.4 Physical tests.

S10.13.4.1 Each sealed beam headlamp must be designed to conform to the performance requirements of the corrosion test, vibration test, inward force test, torque deflection test, headlamp connector test, headlamp wattage test, and aiming adjustment tests of S14.6.

S10.13.4.2 Each sealed beam headlamp except a Type G or Type H must be designed to conform to the performance requirements of the retaining ring test of S14.6.

S10.13.4.3 Each sealed beam headlamp must be designed to conform to the performance requirements of the color test of S14.4. Each sealed beam headlamp that does not incorporate a glass lens must be designed to conform to the plastic optical materials test of S14.4.

S10.14 Integral beam headlighting systems. All integral beam headlighting systems must be of a type designated in Table II-c.

S10.14.1 Installation. An integral beam headlighting system must consist of the correct number of designated headlamp units as specified for the applicable system in Table II-c. The units must have their beams activated as specified in Table II-c. A system must provide in total not more than two upper beams and two lower beams.

S10.14.2 Aimability.

S10.14.2.1 A system that incorporates any headlamp or beam contributor that does not have a VHAD as an integral and indivisible part of the headlamp or beam contributor must be designed so that the applicable photometric requirements are met when any correctly aimed and photometrically conforming headlamp or beam contributor is removed from its mounting and aiming mechanism, and is replaced without reaim by any conforming headlamp or beam contributor of the same type.

S10.14.2.2 A system that incorporates more than one beam contributor providing a lower beam, and/or more than one beam contributor providing an upper beam, shall be designed to conform to the on-vehicle aiming requirements specified in S10.18.8.

S10.14.3 Simultaneous aim. An integral beam headlighting system consisting of four individual headlamps or beam contributors may have the headlamp units mounted in an assembly to permit simultaneous aiming of the beam(s) contributors, providing that with any complying contributor the assembly complete with all lamps meets the applicable photometric requirements when tested in accordance with S14.2.5.

S10.14.4 Markings. An integral beam headlamp with a single light source providing the lower beam must have its lens permanently marked with "L". An integral beam headlamp with a single light source providing the upper beam must have its lens permanently marked with "U".

S10.14.5 Additional light sources. An integral beam headlamp may incorporate light sources that are used for purposes other than headlighting and are capable of being replaced.

S10.14.6 Photometry. Each integral beam headlamp must be designed to conform to the photometry requirements of Table XVIII for upper beam and Table XIX for lower beam as specified in Table II-c for the specific headlamp unit and aiming method, when tested according to the procedure of S14.2.5.

S10.14.7 Physical tests.

S10.14.7.1 Each integral beam headlamp must be designed to conform to the performance requirements of the corrosion test, temperature cycle test, vibration test, inward force test, headlamp connector test, and aiming adjustment tests of S14.6.

S10.14.7.2 Each integral beam headlamp that is not designed to conform to the performance requirements of the sealing test of S14.6 must be designed to conform to the performance requirements of the connector-corrosion test, dust test, and humidity test of S14.6.

S10.14.7.3 Each integral beam headlamp except those with a glass lens must be designed to conform to the performance requirements of the abrasion test of S14.6.

S10.14.7.4 Each integral beam headlamp except those with a nonreplaceable glass lens must be designed to conform to the performance requirements of the chemical resistance test of S14.6.

S10.14.7.5 Each integral beam headlamp except those with a glass lens and a non-plastic reflector must be designed to conform to the performance requirements of the internal heat test of S14.6.

S10.14.7.6 Each integral beam headlamp incorporating a replaceable lens must be designed to conform to the performance requirements of the chemical resistance of reflectors of replaceable lens headlamps test and the corrosion resistance of reflectors of replaceable lens headlamps test of S14.6.

S10.14.7.7 Each integral beam headlamp capable of being mechanically aimed by externally applied headlamp aiming devices specified in SAE J602 OCT80, Headlamp Aiming Device for Mechanically Aimable Sealed Beam Headlamp Units, (incorporated by reference, see 571.108 S5.2 of this title) must be designed to conform to the performance requirements of the torque deflection test of S14.6.

S10.14.7.8 Each integral beam headlamp must be designed to conform to the performance requirements of the color test of S14.4. Each integral beam headlamp that does not incorporate a glass lens must be designed to conform to the performance requirements of the plastic optical materials test of S14.4.

S10.15 Replaceable bulb headlighting systems. All replaceable bulb headlighting systems must be of a type designated in Table II-d.

S10.15.1 Installation. A replaceable bulb headlighting system must consist of either two or four headlamps as

specified for the applicable system in Table II-d. The headlamps must have their beams activated as specified in Table II-d. A system must provide in total not more than two upper beams and two lower beams and must incorporate not more than two replaceable light sources in each headlamp.

S10.15.2 *Aiming restrictions.* Each replaceable bulb headlamp designed to conform to the external aiming requirements of S10.18.7 must have no mechanism that allows adjustment of an individual light source, or if there are two light sources, independent adjustments of each reflector.

S10.15.3 *Replacement lens reflector units.* Each lens reflector unit manufactured as replacement equipment must be designed to conform to applicable photometry requirements when any replaceable light source designated for such a unit is inserted in it.

S10.15.4 *Markings.*

S10.15.4.1 A replaceable bulb headlamp in a four headlamp system providing lower beam must have its lens permanently marked with "L". A replaceable bulb headlamp in a four headlamp system providing upper beam must have its lens permanently marked with "U".

S10.15.4.1.1 No such markings are required if the light sources in the headlamp are any combination of dual filament light sources other than HB2.

S10.15.5 *Additional light sources.* A replaceable bulb headlamp may incorporate replaceable light sources that are used for purposes other than headlighting.

S10.15.6 *Photometry.* Each replaceable bulb headlamp must be designed to conform to the photometry requirements of Table XVIII for upper beam and Table XIX for lower beam as specified in Table II-d for the specific headlamp unit and aiming method, when tested according to the procedure of S14.2.5 using any replaceable light source designated for use in the system under test.

S10.15.7 *Physical tests.*

S10.15.7.1 Each replaceable bulb headlamp must be designed to conform to the performance requirements of the corrosion test, corrosion-connector test, dust test, temperature cycle test, humidity test, vibration test, inward force test, headlamp connector test, and aiming adjustment tests of S14.6.

S10.15.7.2 Each replaceable bulb headlamp except those with a glass lens must be designed to conform to the performance requirements of the abrasion test of S14.6.

S10.15.7.3 Each replaceable bulb headlamp except those with a nonreplaceable glass lens must be designed to conform to the performance requirements of the chemical resistance test of S14.6.

S10.15.7.4 Each replaceable bulb headlamp except those with a glass lens and a non-plastic reflector must be designed to conform to the performance requirements of the internal heat test of S14.6.

S10.15.7.5 Each replaceable bulb headlamp incorporating a replaceable lens must be designed to conform to the performance requirements of the chemical resistance of reflectors of replaceable lens headlamps test and the corrosion resistance of reflectors of replaceable lens headlamps test of S14.6.

S10.15.7.6 Each replaceable bulb headlamp capable of being mechanically aimed by externally applied headlamp aiming devices specified in SAE J602 OCT80, *Headlamp Aiming Device for Mechanically Aimable Sealed Beam Headlamp Units*, (incorporated by reference, see 571.108 S5.2 of this title) must be designed to conform to the performance requirements of the torque deflection test of S14.6.

S10.15.7.7 Each replaceable bulb headlamp must be designed to conform to the performance requirements of the color test of S14.4. Each replaceable bulb headlamp that does not incorporate a glass lens must be designed to conform to the performance requirements of the plastic optical materials test of S14.4.

S10.16 *Combination headlighting systems.* All combination headlighting systems must be of a type designated in Table II-b.

S10.16.1 *Installation.* A combination headlighting system must consist of the correct number of designated headlamp units as specified for the applicable system in Table II-b. The units must have their beams activated as specified in Table II-b. A system must provide in total not more than two upper beams and two lower beams. When installed on a motor vehicle, the headlamps (or parts thereof) that provide the lower beam must be of the same type, and provide a symmetrical effective projected luminous lens area when illuminated.

S10.16.2 *Photometry.* Each combination headlamp must be designed to conform to the photometry requirements of Table XVIII for upper beam and Table XIX for lower beam as specified in Table II-b for the specific headlamp unit and aiming method,

when tested according to the procedure of S14.2.5.

S10.16.3 *Physical tests.*

S10.16.3.1 Any component headlamp of a combination headlighting system that is a Type F sealed beam headlamp must be designed to conform to the performance requirements of S10.13.4.

S10.16.3.2 Any component headlamp of a combination headlighting system that is an integral beam headlamp must be designed to conform to the performance requirements of S10.14.7.

S10.16.3.3 Any component headlamp of a combination headlighting system that is a replaceable bulb headlamp must be designed to conform to the performance requirements of S10.15.7.

S10.17 *Motorcycle headlighting systems.* A motorcycle headlighting system may consist of:

(a) One half of any headlighting system of Table II which provides both a full upper beam and full lower beam, and is designed to conform to the requirements for that headlamp type. Where more than one lamp must be used, the lamps shall be mounted vertically, with the lower beam as high as practicable, or

(b) A headlighting system designed to conform to the requirements of paragraphs S10.17.1 through S10.17.5.

S10.17.1 *Installation.* The headlighting system installed on a motorcycle must consist of one of the system types specified in this paragraph, and must be located on the front.

S10.17.1.1 *Single headlamp.*

S10.17.1.1.1 If the system consists of a single headlamp, it must be mounted on the vertical centerline of the motorcycle.

S10.17.1.1.2 If the headlamp contains more than one light source, each light source must be mounted on the vertical centerline with the upper beam no higher than the lower beam, or horizontally disposed about the vertical centerline and mounted at the same height.

S10.17.1.1.3 If the light sources are horizontally disposed about the vertical centerline, the distance between the closest edges of the effective projected luminous lens area in front of the light sources must not be greater than 200 mm.

S10.17.1.2 *Two headlamps with both beams.*

S10.17.1.2.1 If the system consists of two headlamps, each of which provides both an upper and lower beam, the headlamps must be mounted either at the same height and symmetrically

disposed about the vertical centerline or mounted on the vertical centerline.

S10.17.1.2.2 If the headlamps are horizontally disposed about the vertical centerline, the distance between the closest edges of their effective projected luminous lens areas must not be greater than 200 mm.

S10.17.1.3 *Two headlamps, upper beam and lower beam.*

S10.17.1.3.1 If the system consists of two headlamps, one of which provides an upper beam and one of which provides the lower beam, the headlamps must be located on the vertical centerline with the upper beam no higher than the lower beam, or horizontally disposed about the vertical centerline and mounted at the same height.

S10.17.1.3.2 If the headlamps are horizontally disposed about the vertical centerline, the distance between the closest edges of their effective projected luminous lens areas must not be greater than 200 mm.

S10.17.2 *Motorcycle replaceable bulb headlamp marking.* Each replaceable bulb headlamp that is designed to conform to S10.17(b) and that is equipped with a light source other than a replaceable light source meeting the requirements of S11, must have the word "motorcycle" permanently marked on the lens in characters not less than 3 mm in height.

S10.17.3 *Photometry.* Each motorcycle headlamp that is not designed to conform to S10.17(a), must be designed to conform to the photometry requirements of Table XX when tested according to the procedure of S14.2.5.

S10.17.4 *Physical tests.* Each motorcycle headlamp that is not designed to conform to S10.17(a) must be designed to conform to the performance requirements of the vibration test, moisture test, dust test, and corrosion test of S14.5, the out of focus test of S14.3, the color test of S14.4, and each motorcycle headlamp that does not incorporate a glass lens must be designed to conform to the performance requirements of the plastic optical materials test of S14.4.

S10.17.5 *Motorcycle headlamp modulation system.* A headlamp on a motorcycle may be activated to modulate either the upper beam or the lower beam from its maximum intensity to a lesser intensity, provided that:

S10.17.5.1 *Modulation.*

(a) The rate of modulation must be 240 ± 40 cycles per minute.

(b) The headlamp must be operated at maximum power for 50 to 70 percent of each cycle.

(c) The lowest intensity at any test point must be not less than 17 percent of the maximum intensity measured at the same point.

(d) The modulator switch must be wired in the power lead of the beam filament being modulated and not in the ground side of the circuit.

(e) Means must be provided so that both the lower beam and upper beam remain operable in the event of a modulator failure.

(f) The system must include a sensor mounted with the axis of its sensing element perpendicular to a horizontal plane. Headlamp modulation must cease whenever the level of light emitted by a tungsten filament light operating at 3000° Kelvin is either less than 270 lux of direct light for upward pointing sensors or less than 60 lux of reflected light for downward pointing sensors. The light is measured by a silicon cell type light meter that is located at the sensor and pointing in the same direction as the sensor. A Kodak Gray Card (Kodak R-27) is placed at ground level to simulate the road surface in testing downward pointing sensors.

(g) When tested in accordance with the test profile shown in Figure 9, the voltage drop across the modulator when the lamp is on at all test conditions for 12 volt systems and 6 volt systems must not be greater than 0.45 volt. The modulator must meet all the provisions of the standard after completion of the test profile shown in Figure 9.

(h) Means must be provided so that both the lower and upper beam function at design voltage when the headlamp control switch is in either the lower or upper beam position when the modulator is off.

S10.17.5.2 *Replacement modulators.* Each modulator not intended as original equipment, or its container, must be labeled with the maximum wattage, and the minimum wattage appropriate for its use.

S10.17.5.2.1 *Replacement performance.* Each modulator, not intended as original equipment, must comply with S10.17.5.1 (a) through (g) when connected to a headlamp of the maximum rated power and a headlamp of the minimum rated power, and must provide means so that the modulated beam functions at design voltage when the modulator is off.

S10.17.5.2.2 *Replacement instructions.* Instructions, with a diagram, must be provided for mounting the light sensor including location on the motorcycle, distance above the road surface, and orientation with respect to the light.

S10.18 *Headlamp aimability performance requirements.*

S10.18.1 *Headlamp mounting and aiming.* Except as provided in this paragraph, each headlamp must be installed on a motor vehicle with a mounting and aiming mechanism that permits aim inspection and adjustment of both vertical and horizontal aim, and is accessible for those purposes without removal of any vehicle parts, except for protective covers removable without the use of tools.

S10.18.1.1 The axis of the light beams must be adjustable to the left, right, up, or down from the designed setting, the amount of adjustability to be determined by practical operating conditions and the type of equipment.

S10.18.1.2 The adjustments must be conveniently made by one person with tools ordinarily available. When the headlamps are secured, the aim will not be disturbed under ordinary conditions of service.

S10.18.2 *Headlamp aiming systems.* When a headlamp system is installed on a motor vehicle, it must be aimable with at least one of the following: An externally applied aiming device, as specified in S10.18.7; an on-vehicle headlamp aiming device installed by the vehicle or lamp manufacturer, as specified in S10.18.8; or by visual/optical means, as specified in S10.18.9.

S10.18.3 *Aim adjustment interaction.* When installed on the vehicle, adjustment of one aim axis through its full on-vehicle range must not cause the aim of the other axis to deviate more than $\pm 0.76^\circ$. If the performance specified is not achievable, the requirements of S10.18.3.1 apply, except that if the aiming mechanism is not a VHAD, the requirements specific to VHADs are not applicable, and the instruction must be specific to the aiming mechanism installed.

S10.18.3.1 Should the mechanism not meet the requirements of S10.18.3, a cautionary label must be placed adjacent to the mechanism stating the caution and including either the reason for the caution or the corrective action necessary. Each such label must also refer the reader to the vehicle operator's manual for complete instructions. Each such vehicle must be equipped with an operator's manual containing the complete instructions appropriate for the mechanism installed.

S10.18.4 *Horizontal adjustment-visually aimed headlamp.* A visually/optically aimable headlamp that has a lower beam must not have a horizontal adjustment mechanism unless such mechanism meets the requirements of this standard for on vehicle aiming as specified in S10.18.8.

S10.18.5 Optical axis marking.

S10.18.5.1 Optical axis marking-vehicle. Each motor vehicle must be equipped with headlamps or beam contributors which have a mark or markings that are visible from the front of the headlamp when installed on the vehicle to identify the optical axis of the headlamp to assure proper horizontal and vertical alignment of the aiming screen or optical aiming equipment. The manufacturer is free to choose the design of the mark or markings. The mark or markings may be on the interior or exterior of the lens or indicated by a mark or central structure on the interior or exterior of the headlamp.

S10.18.5.2 Optical axis marking-lamp. Each headlamp or beam contributor that is not visually/optically aimable in accordance with S10.18.9 of this standard must be equipped with fiducial marks, aiming pads, or similar references of sufficient detail and accuracy, for determination of an appropriate vehicle plane to be used with the photometric procedures of S14.2.5 for correct alignment with the photometer axis when being tested for photometric compliance, and to serve for the aiming reference when the headlamp or beam contributor is installed on a motor vehicle. The fiducial marks, aiming pads, or similar references are protrusions, bubble vials, holes, indentations, ridges, scribed lines, or other readily identifiable marks established and described by the vehicle or headlamp manufacturer.

S10.18.5.3 Optical axis marking-visual/optical aim headlamp. There must be a mark or markings identifying the optical axis of the headlamp visible from the front of the headlamp when installed on the vehicle, to assure proper horizontal and vertical alignment of the aiming screen or optical aiming equipment with the headlamp being aimed. The manufacturer is free to choose the design of the mark or markings. The mark or markings may be on the interior or exterior of the lens or indicated by a mark or central structure on the interior or exterior of the headlamp.

S10.18.6 Moveable reflectors. Each headlamp aimed by moving the reflector relative to the lens and headlamp housing, or vice versa, must conform with the photometric requirements applicable to it when tested according to the procedure of S14.2.5 with the lens at any position relative to the reflector within the full range of vertical pitch on the vehicle on which the headlamp system is installed and a horizontal range of $\pm 2.5^\circ$. Additionally it must comply with the aiming adjustment requirements of S14.6.

S10.18.7 External aiming. Each headlighting system that is capable of being mechanically aimed by externally applied headlamp aiming devices must be mechanically aimable using the equipment specified in SAE J602 *Headlamp Aiming Device for Mechanically Aimable Sealed Beam Headlamp Units*, October 1980, (incorporated by reference, see 571.108 S5.2 of this title) without the removal of any ornamental trim rings, covers, wipers or other vehicle parts.

S10.18.7.1 Headlamp aiming device locating plates. Each headlighting system which is designed to use the Headlamp Aiming Device Locating Plates with adjustable legs for the 100×165 mm unit and the 142×200 mm unit, and which has adjustable length legs, must meet the following requirements:

S10.18.7.1.1 The lens must have three aiming pads which meet the requirements of Figure 4, *Dimensional Specifications for Location of Aiming Pads on Replaceable Bulb Headlamp Units*. The aiming pads need not be centered at the geometric center of the lens, or on the optical axis. Except as provided in S10.18.7.1.2, a whole number, which represents the distance in tenths of an inch (i.e. 0.3 inch = 3) from the aiming reference plane to the respective aiming pads which are not in contact with that plane, must be inscribed adjacent to each respective aiming pad on the lens. The height of these numbers must be not less than .157 inch (4 mm). If there is interference between the plane and the area of the lens between the aiming pads, the whole number represents the distance to a secondary plane. The secondary plane must be located parallel to the aiming reference plane and as close to the lens as possible without causing interference.

S10.18.7.1.2 If the most forward aiming pad is the lower inboard aiming pad, then the dimensions may be placed anywhere on the lens. The dimension for the outboard aiming pad (Dimension F in Figure 4) must be followed by the letter "H" and the dimension for the center aiming pad must be followed by the letter "V." The dimensions must be expressed in tenths of an inch.

S10.18.7.2 Nonadjustable headlamp aiming device locating plates. Each headlamp may be designed to use the nonadjustable Headlamp Aiming Device Locating Plate for the 100×165 mm unit, the 142×200 mm unit, the 146 mm diameter unit, or the 178 mm diameter unit of SAE J602 OCT80, *Headlamp Aiming Device for Mechanically Aimable Sealed Beam Headlamp Units*, (incorporated by reference, see 571.108

S5.2 of this title), or the 92×150 mm Type F unit, and incorporate lens-mounted aiming pads as specified for those units pursuant to Appendix C of part 564 of this chapter. If so designed, no additional lens marking is necessary to designate the type of plate or dimensions.

S10.18.8 On-vehicle aiming. Each headlighting system that is capable of being aimed by equipment installed on the vehicle must include a Vehicle Headlamp Aiming Device (VHAD) that conforms to the following requirements:

S10.18.8.1 Aim. The VHAD must provide for headlamp aim inspection and adjustment in both the vertical and horizontal axes.

S10.18.8.1.1 Vertical aim. The VHAD must include the necessary references and scales relative to the horizontal plane to assure correct vertical aim for photometry and aiming purposes. An off vehicle measurement of the angle of the plane of the ground is permitted. In addition, an equal number of graduations from the "0" position representing angular changes in the axis in the upward and downward directions must be provided.

S10.18.8.1.1.1 Each graduation must represent a change in the vertical position of the mechanical axis not larger than 0.19° (1 in at 25 ft) to provide for variations in aim at least 1.2° above and below the horizontal, and have an accuracy relative to the zero mark of less than 0.1° .

S10.18.8.1.1.2 The VHAD must be marked to indicate headlamp aim movement in the upward and downward directions.

S10.18.8.1.1.3 Each graduation must indicate a linear movement of the scale indicator of not less than 0.05 in (1.27 mm) if a direct reading analog indicator is used. If a remote reading indicator is provided, it must represent the actual aim movement in a clear, understandable format.

S10.18.8.1.1.4 The vertical indicator must perform through a minimum range of $\pm 1.2^\circ$.

S10.18.8.1.1.5 Means must be provided in the VHAD for compensating for deviations in floor slope less than 1.2° from the horizontal that would affect the correct positioning of the headlamp for vertical aim.

S10.18.8.1.1.6 The graduations must be legible under an illumination level not greater than 30 foot candles, measured at the top of the graduation, by an observer having 20/20 vision (Snellen), and must permit aim adjustment to within 0.19° (1 in at 25 ft).

S10.18.8.1.2 Horizontal aim. The VHAD must include references and scales relative to the longitudinal axis of

the vehicle necessary to assure correct horizontal aim for photometry and aiming purposes. An "0" mark must be used to indicate alignment of the headlamps relative to the longitudinal axis of the vehicle. In addition, an equal number of graduations from the "0" position representing equal angular changes in the axis relative to the vehicle axis must be provided.

S10.18.8.1.2.1 Each graduation must represent a change in the horizontal position of the mechanical axis not greater than 0.38° (2 in at 25 ft) to provide for variations in aim at least 0.76° (4 in at 25 ft) to the left and right of the longitudinal axis of the vehicle, and must have an accuracy relative to the zero mark of less than 0.1° .

S10.18.8.1.2.2 The VHAD must be marked to indicate headlamp aim movement in the left and right directions.

S10.18.8.1.2.3 The graduations must be legible under an illumination level not greater than 30 foot candles, measured at the top of the graduation, by an observer having 20/20 vision (Snellen), and must permit aim adjustment to within 0.38° (2 in at 25 ft).

S10.18.8.1.2.4 The horizontal indicator must perform through a minimum range of $\pm 0.76^\circ$ (4 in at 25 ft); however, the indicator itself must be capable of recalibration over a movement of $\pm 2.5^\circ$ relative to the longitudinal axis of the vehicle to accommodate any adjustment necessary for recalibrating the indicator after vehicle repair from accident damage.

S10.18.8.2 Aiming instructions.

S10.18.8.2.1 The instructions for properly aiming the headlighting system using the VHAD must be provided on a label permanently affixed to the vehicle adjacent to the VHAD, or in the vehicle operator's manual. The instructions must advise that the headlighting system is properly aimed if the appropriate vertical plane (as defined by the vehicle manufacturer) is perpendicular to both the longitudinal axis of the vehicle, and a horizontal plane when the vehicle is on a horizontal surface, and the VHAD is set at "0" vertical and "0" horizontal.

S10.18.8.2.2 Should a remote indicator or a remote indicator and adjuster be provided, the instructions must be placed in the operator's manual, and may also be placed on a label adjacent to the VHAD.

S10.18.8.3 *Permanent calibration.* Each headlamp equipped with a VHAD must be manufactured with its calibration permanently fixed by its manufacturer. Calibration in this case means the process of accurately aligning the geometry of the VHAD devices with

the beam pattern for the purposes of compliance with the standard.

S10.18.8.4 *Replacement units.* When tested according to the procedure of S14.2.5 with any replacement headlamp unit(s) or light sources intended for use in the system under test, the VHAD and headlighting system must be designed to conform to the photometric performance requirements applicable for the system under test.

S10.18.8.5 *Physical tests.* Each VHAD must be designed to conform with the performance requirements of S14.8.

S10.18.9 *Visual/optical aiming.* Each visually/optically aimable headlamp must be designed to conform to the following requirements:

S10.18.9.1 *Vertical aim, lower beam.* Each lower beam headlamp must have a cutoff in the beam pattern. It may be either on the left side or the right side of the optical axis, but once chosen for a particular headlamp system's design, the side chosen for the cutoff must not be changed for any headlamps intended to be used as replacements for those system's headlamps.

S10.18.9.1.1 *Vertical position of the cutoff.* The headlamp must be aimed vertically so that the cutoff is on the left side, at 0.4° down from the H-H line, or on the right side, at the H-H line.

S10.18.9.1.2 *Vertical gradient.* The gradient of the cutoff measured at either 2.5° L or 2.0° R must be not less than 0.13 based on the procedure of S10.18.9.1.5.

S10.18.9.1.3 *Horizontal position of the cutoff.* The width must be not less than 2° , with not less than 2° of its actual width centered at either 2.5° L, or 2.0° R.

S10.18.9.1.4 *Maximum inclination of the cutoff.* The vertical location of the highest gradient at the ends of the minimum width must be within $\pm 0.2^\circ$ of the vertical location of the maximum gradient measured at the appropriate vertical line (at either 2.5° L for a left side cutoff, or 2.0° R for a right side cutoff).

S10.18.9.1.5 *Measuring the cutoff parameter.*

S10.18.9.1.5.1 The headlamp is mounted on a headlamp test fixture which simulates its actual design location on any vehicle for which the headlamp is intended. The fixture, with the headlamp installed, is attached to the goniometer table in such a way that the fixture alignment axes are coincident with the goniometer axes. The headlamp is energized at the specified test voltage. The cutoff parameter must be measured at a distance of 10 m from a photosensor with a 10 mm diameter.

S10.18.9.1.5.2 The headlamp beam pattern is aimed with the cutoff at the H-H axis. There is no adjustment, shimming, or modification of the horizontal axis of the headlamp or test fixture, unless the headlamp is equipped with a VHAD. In this case the VHAD is adjusted to zero.

S10.18.9.1.5.3 A vertical scan of the beam pattern is conducted for a headlamp with a left side gradient by aligning the goniometer on a vertical line at 2.5° L and scanning from 1.5° U to 1.5° D. For a headlamp with a right side gradient, a vertical scan of the beam pattern is conducted by aligning the goniometer on a vertical line at 2.0° R and scanning from 1.5° U to 1.5° D.

S10.18.9.1.5.4 Determine the maximum gradient within the range of the scan by using the formula: $G = \log E(a) - \log E(a + 0.1)$, where "G" is the gradient, "E" is illumination and "a" is vertical angular position. The maximum value of the gradient "G" determines the vertical angular location of the cutoff. Perform vertical scans at 1.0° L and R of the measurement point of the maximum gradient to determine the inclination.

S10.18.9.2 *Horizontal aim, lower beam.* There is no adjustment of horizontal aim unless the headlamp is equipped with a horizontal VHAD. If the headlamp has a VHAD, it is set to zero.

S10.18.9.3 *Vertical aim, upper beam.*

S10.18.9.3.1 If the upper beam is combined in a headlamp with a lower beam, the vertical aim of the upper beam must not be changed from the aim set using the procedures of S10.18.9.1 and S10.18.9.2 used for the lower beam.

S10.18.9.3.2 If the upper beam is not combined in a headlamp with a lower beam, the vertical aim of the upper beam is adjusted so that the maximum beam intensity is located on the H-H axis.

S10.18.9.4 *Horizontal aim, upper beam.*

S10.18.9.4.1 If the upper beam is combined in a headlamp with a lower beam, the horizontal aim of the upper beam must not be changed from the aim set using the procedures of S10.18.9.1 and S10.18.9.2 used for the lower beam.

S10.18.9.4.2 If the upper beam is not combined in a headlamp with the lower beam and has fixed horizontal aim or has a horizontal VHAD, then the headlamp is mounted on a headlamp test fixture which simulates its actual design location on any vehicle for which the headlamp is intended. The fixture, with the headlamp installed, is attached to the goniometer table in such a way that the fixture alignment axes are

coincident with the goniometer axes. The headlamp must be energized at 12.8 ± 0.20 mV. There is no adjustment, shimming, or modification of the horizontal axis of the headlamp or test fixture, unless the headlamp is equipped with a VHAD. In this case the VHAD is adjusted to zero.

S10.18.9.4.3 If the upper beam is not combined in a headlamp with a lower beam, and it does not have a VHAD, the horizontal aim of the upper beam is adjusted so that the maximum beam intensity is located on the V-V axis.

S10.18.9.5 *Photometry*. When tested according to the procedure of S14.2.5, a visually/optically aimable headlamp must be designed to conform to the lower beam requirements of columns; LB1V or LB2V of Table XIX-a, or LB3V of Table XIX-b, or LB4V of Table XIX-c.

S10.18.9.6 *Visual/optical aiming identification marking*. Each letter used in marking according to this paragraph must be not less than 3 mm high.

S10.18.9.6.1 The lens of a lower beam headlamp must be marked "VOL" if the headlamp is intended to be visually/optically aimed using the left side of the lower beam pattern. The lens of a lower beam headlamp must be marked "VOR" if the headlamp is intended to be visually/optically aimed using the right side of the lower beam pattern. The lens of a headlamp that is solely an upper beam headlamp and intended to be visually/optically aimed using the upper beam must be marked "VO".

S10.18.9.6.2 The lens of each sealed beam or integral beam headlamp must be marked "VOR" if the headlamp is of a type that was manufactured before May 1, 1997, and if such headlamp type has been redesigned since then to be visually/optically aimable.

S11 *Replaceable light source requirements*. Each replaceable light source must be designed to conform to the dimensions and electrical specifications furnished with respect to it pursuant to part 564 of this chapter, on file in Docket No. NHTSA 98-3397, and must conform to the following requirements:

S11.1 *Markings*. If other than an HB Type, the light source must be marked with the bulb marking designation specified for it in compliance with Appendix A or Appendix B of part 564 of this chapter. The base of each HB Type must be marked with its HB Type designation. Each replaceable light source must also be marked with the symbol DOT and with a name or trademark in accordance with S6.5.

S11.2 *Ballast markings*. If a ballast is required for operation, each ballast must bear the following permanent markings:

- (a) Name or logo of ballast manufacturer;
- (b) Ballast part number or unique identification;
- (c) Part number or other unique identification of the light source for which the ballast is designed;
- (d) Rated laboratory life of the light source/ballast combination, if the information for the light source has been filed in Appendix B of part 564 of this chapter;
- (e) A warning that ballast output voltage presents the potential for severe electrical shock that could lead to permanent injury or death;
- (f) Ballast output power in watts and output voltage in rms volts AC or DC; and
- (g) The symbol 'DOT'.

S11.3 *Gas discharge laboratory life*. For light sources that use excited gas mixtures as a filament or discharge arc, the "rated laboratory life" is determined in accordance with sections 4.3 and 4.9 of SAE Recommended Practice J2009 FEB93, Forward Discharge Lighting Systems (incorporated by reference, see 571.108 S5.2 of this title).

S11.4 *Physical tests*.

S11.4.1 Each replaceable light source must be designed to conform with the performance requirements of the deflection test and pressure test requirements of S14.7.

S11.4.2 Replaceable light sources must be designed to conform with the requirements of section VII of Appendix A of part 564 of this chapter, or section IV of Appendix B of part 564 of this chapter, for maximum power and luminous flux when test by the procedure of S14.7.3.

S12 *Headlamp concealment device requirements*.

S12.1 While the headlamp is illuminated, its fully opened headlamp concealment device must remain fully opened should any loss of power to or within the headlamp concealment device occur.

S12.2 Whenever any malfunction occurs in a component that controls or conducts power for the actuation of the concealment device, each closed headlamp concealment device must be capable of being fully opened by a means not requiring the use of any tools. Thereafter, the headlamp concealment device must remain fully opened until intentionally closed.

S12.3 Except for malfunctions covered by S12.2, each headlamp concealment device must be capable of being fully opened and the headlamps illuminated by actuation of a single

switch, lever, or similar mechanism, including a mechanism that is automatically actuated by a change in ambient light conditions.

S12.4 Each headlamp concealment device must be installed so that the headlamp may be mounted, aimed, and adjusted without removing any component of the device, other than components of the headlamp assembly.

S12.5 Except for cases of malfunction covered by S12.2, each headlamp concealment device must, within an ambient temperature range of -20 °F to $+120$ °F, be capable of being fully opened in not more than 3 seconds after the actuation of a driver-operated control.

S12.6 As an alternative to complying with the requirements of S12.1 through S12.5, a vehicle with headlamps incorporating VHAD or visual/optical aiming in accordance with this standard may meet the requirements for *Concealable lamps* in paragraph 5.14 of the following version of the Economic Commission for Europe Regulation 48 "Uniform Provisions Concerning the Approval of Vehicles With Regard to the Installation of Lighting and Light-Signaling Devices": E/ECE/324-E/ECE/TRANS/505, Rev.1/Add.47/Rev.1/Corr.2, 26 February 1996 (page 17) (incorporated by reference, see 571.108 S5.2 of this title), in the English language version.

S12.7 *Certification election*. Manufacturers of vehicles with headlamps incorporating VHAD or visual/optical aiming must elect to certify to S12.1 through S12.5 or to S12.6 prior to, or at the time of certification of the vehicle, pursuant to 49 CFR Part 567. The selection is irrevocable.

S13 *Replaceable headlamp lens requirements*.

S13.1 A replacement lens for a replaceable bulb headlamp or integral beam headlamp that is not required to have a bonded lens must be provided with a replacement seal in a package that includes instructions for the removal and replacement of the lens, the cleaning of the reflector, and the sealing of the replacement lens to the reflector assembly.

S13.2 Each replacement headlamp lens with seal, when installed according to the lens manufacturer's instructions on an integral beam or replaceable bulb headlamp, must not cause the headlamp to fail to comply with any of the requirements of this standard.

S13.3 Each replacement headlamp lens must be marked with the symbol "DOT" either horizontally or vertically, to constitute certification. Each replacement headlamp lens must also be

marked with manufacturer and the part or trade number of the headlamp for which it is intended, and with the name and/or trademark of the lens manufacturer or importer that is registered with the U.S. Patent and Trademark Office. Nothing in this standard authorizes the marking of any such name and/or trademark by one who is not the owner, unless the owner has consented to it.

S14 Physical and photometry test procedures and performance requirements.

S14.1 General test procedures and performance requirements.

S14.1.1 Each lamp, reflective device, item of conspicuity treatment, and item of associated equipment required or permitted by this standard must be designed to conform to all applicable physical test performance requirements specified for it.

S14.1.2 *Plastic optical materials.* All plastic materials used for optical parts such as lenses and reflectors on lamps or reflective devices required or allowed by this standard must conform to the material test requirements of S14.4.2.

S14.1.3 All coatings used on optical materials must have added to their formulations an optical brightener, whose presence is detectable by ultraviolet light, to aid in testing for their presence. Other equivalent industry accepted methods may be used as an alternative.

S14.1.4 Samples.

S14.1.4.1 Samples submitted for laboratory test must be new, unused, manufactured from production tooling and assembled by production processes, and representative of the devices as regularly manufactured and marketed.

S14.1.4.2 Each test sample must include not only the device but also accessory equipment necessary to operate in its intended manner. Where necessary a mounting bracket shall be provided so that the device may be rigidly bolted in its operating position on the various test equipment.

S14.1.4.3 Dust and photometric tests may be made on a second set of mounted samples, if desired, to expedite completion of the tests.

S14.1.5 *Laboratory facilities.* The laboratory must be equipped to test the sample in accordance with the requirements of the specific device.

S14.2 Photometric test procedures. Each lamp and reflective device required or permitted by this standard must be designed to conform to the applicable photometric requirements.

S14.2.1 Photometry measurements for all lamps except license plate lamps, headlamps, and DRLs.

S14.2.1.1 *Mounting.* Photometry measurements are made with the sample lamp mounted in its normal operating position.

S14.2.1.2 *School bus signal lamp aiming.* A school bus signal lamp must be aimed with its aiming plane normal to the photometer axis and may be reaimed for photometry by $\pm 1/2^\circ$ vertically and $\pm 1^\circ$ horizontally.

S14.2.1.3 *Measurement distance.* Photometric measurements are made at a distance between the light source and the point of measurement of at least 1.2 m for side marker lamps, clearance lamps, identification lamps, and parking lamps, and at least 3 m for turn signal lamps, stop lamps, taillamps, backup lamps, and school bus signal lamps.

S14.2.1.4 *Location of test points.* Test point location must comply with the following nomenclature:

(a) The line formed by the intersection of a vertical plane through the light source of the lamp and normal to the test screen is designated "V".

(b) The line formed by the intersection of a horizontal plane through the light source and normal to the test screen is designated "H".

(c) The point of intersection of these two lines is designated "H-V".

(d) Other test points on the test screen are measured in terms of angles from the H and V lines.

(e) Angles to the right (R) and to the left (L) are regarded as being to the right and left of the V line when the observer stands behind the lamp and looks in the direction of its light beam when it is properly aimed for photometry. Similarly, the upward angles designated as U and the downward angles designated as D, refer to light directed at angles above and below the H line, respectively.

S14.2.1.5 Multiple compartment and multiple lamp photometry of turn signal lamps, stop lamps, and taillamps.

S14.2.1.5.1 When compartments of lamps or arrangements of multiple lamps are photometered together, the H-V axis intersects the midpoint between the optical axes.

S14.2.1.5.2 Luminous intensity measurements of multiple compartment lamp or multiple lamp arrangements are made either by:

(a) Measuring all compartments together, provided that a line from the optical axis of each compartment or lamp to the center of the photometer sensing device does not make an angle more than 0.6° with the H-V axis, or

(b) Measuring each compartment or lamp separately by aligning its optical axis with the photometer and adding the value at each test point.

S14.2.1.5.3 Multiple compartment turn signal lamps or stop lamps or multiple lamp arrangements of these lamps installed on multipurpose passenger vehicles, trucks, trailers, or buses 2032 mm or more in overall width must use the method of S14.2.1.5.2(b) only.

S14.2.1.6 *Bulbs.* Except for a lamp having a sealed-in bulb, a lamp must meet the applicable requirements of this standard when tested with a bulb whose filament is positioned within $\pm .010$ in of the nominal design position specified in SAE J573d, *Lamp Bulbs and Sealed Units*, December 1968, (incorporated by reference, see 571.108 S5.2 of this title) or specified by the bulb manufacturer and operated at the bulb's rated mean spherical candela.

S14.2.1.6.1 Each lamp designed to use a type of bulb that has not been assigned a mean spherical candela rating by its manufacturer and is not listed in SAE J573d, *Lamp Bulbs and Sealed Units*, December 1968 (incorporated by reference, see 571.108 S5.2 of this title), must meet the applicable requirements of this standard when used with any bulb of the type specified by the lamp manufacturer, operated at the bulb's design voltage. A lamp that contains a sealed-in bulb must meet these requirements with the bulb operated at the bulb's design voltage.

S14.2.1.6.2 A bulb that is not listed in SAE J573d, *Lamp Bulbs and Sealed Units*, December 1968, (incorporated by reference, see 571.108 S5.2 of this title) is not required to use a socket that conforms to the requirements of SAE J567b, *Bulb Sockets*, April 1964 (incorporated by reference, see 571.108 S5.2 of this title).

S14.2.2 License plate lamp photometry. Photometry compliance of license plate lamps is determined by measurement of the illumination falling upon test stations located on a test plate.

S14.2.2.1 *Illumination surface.* All illumination measurements are made on a rectangular test plate of clean, white blotting paper mounted on the license plate holder in the position normally taken by the license plate. The face of the test plate must be 1.5 mm from the face of the license plate holder.

S14.2.2.2 *Test stations.* Test stations must be located on the face of the test plate as shown in Figure 19 according to the type of vehicle on which the license plate lamps are installed.

S14.2.2.3 Bulb requirements of S14.2.1.6 apply to license plate lamp photometry.

S14.2.3 Reflex reflector and retroreflective sheeting photometry.

S14.2.3.1 *Mounting.* Each reflex reflector is mounted for photometry

with the center of the reflex area at the center of goniometer rotation and at the same horizontal level as the source of illumination.

S14.2.3.2 *Illumination source.* The source of illumination is a lamp with a 50 mm effective diameter and with a filament operating at 2856 °K.

S14.2.3.3 *Measurement distance.* The test distance is 30.5 m [100ft].

S14.2.3.4 *Test setup* The observation point is located directly above the source of illumination. The H-V axis of reflex reflectors is taken as parallel to the longitudinal axis of the vehicle for rear reflectors and perpendicular to a vertical plane passing through the longitudinal axis of the vehicle for side reflectors.

S14.2.3.5 *Photodetector.* The photodetector has an opening of not more than 13 mm vertically and 25 mm horizontally.

S14.2.3.6 *Photometry surface.* Reflex reflectors may have any linear or area dimensions but must have no more than 7740 sq mm projected area contained within a 254 mm diameter circle exposed for photometry.

S14.2.3.7 *Procedure.* Photometric measurements of reflex reflectors and retroreflective sheeting must be made at various observation and entrance angles as shown in Table XVI.

S14.2.3.7.1 The observation angle is the angle formed by a line from the observation point to the center of the reflector and a second line from the center of the reflector to the source of illumination.

S14.2.3.7.2 The entrance angle is the angle between the axis of the reflex reflector and a line from the center of the reflector to the source of illumination.

S14.2.3.7.3 The entrance angle is designated left, right, up, and down in accordance with the position of the source of illumination with respect to the axis of the reflex reflector as viewed from behind the reflector.

S14.2.3.7.4 Measurements are made of the luminous intensity which the reflex reflector is projecting toward the observation point and the illumination on the reflex reflector from the source of illumination.

S14.2.3.8 *Measurements.*

S14.2.3.8.1 *Reflex reflectors.* The required measurement for reflex reflectors at each test point as shown in Table XVI is the quotient of the projected luminous intensity divided by the illumination expressed as millicandela per lux or candela per footcandle.

S14.2.3.8.2 *Retroreflective sheeting.* The required measurement for retroreflective sheeting reflectors at each

test point as shown in Table XVI is candela per lux per square meter of area.

S14.2.3.8.3 *Reflex reflector photometry measurement adjustments.*

S14.2.3.8.3.1 Reflex reflectors, which do not have a fixed rotational position on the vehicle, are rotated about their axis through 360° to find the minimum photometric value which must be reported for each test point. If the output falls below the minimum requirement at any test point, the reflector is rotated $\pm 5^\circ$ about its axis from the angle where the minimum output occurred, and the maximum value within this angle is reported as a tolerance value.

S14.2.3.8.3.2 Reflex reflectors, which by their design or construction, permit mounting on a vehicle in a fixed rotational position, are tested in this position. A visual locator, such as the word TOP is not considered adequate to establish a fixed rotational position on the vehicle.

S14.2.3.8.3.3 If uncolored reflections from the front surface interfere with photometric readings at any test point, additional readings are taken 1° above, below, right, and left of the test point, and the lowest of these readings and its location is reported provided the minimum test point requirement for the test point is met.

S14.2.4 *Daytime running lamp (DRL) photometry measurements.*

S14.2.4.1 Each DRL is tested to the procedure of S14.2.5 when a test voltage of $12.8 \text{ v} \pm 20 \text{ mv}$ is applied to the input terminals of the lamp switch module or voltage-reducing equipment, whichever is closer to the electrical source on the vehicle.

S14.2.4.2 The test distance from the lamp to the photometer is not less than 18.3 m if the lamp is optically combined with a headlamp, or is a separate lamp, and not less than 3 m if the lamp is optically combined with a lamp, other than a headlamp, that is required by this standard.

S14.2.4.3 Bulb requirements of S14.2.1.6 apply to DRL photometry.

S14.2.5 *Headlamp photometry measurements.*

S14.2.5.1 *Mounting.* Photometry measurements at the applicable test points are made with the sample headlamp mounted in its normal operating position.

S14.2.5.2 Test points in the area from 10° U to 90° U must be measured from the normally exposed surface of the lens face.

S14.2.5.3 *Measurement distance.* Photometric measurements are made at a distance between the light source and the photometer sensor of at least 18.3 m.

S14.2.5.4 *Seasoning and test voltage.* All sealed beam headlamps, integral beam headlamps, beam contributors, and replaceable light sources are seasoned at design voltage for 1% of its average design life or 10 hours, whichever is less prior to a photometry test. A headlamp is tested at $12.8 \text{ v} \pm 20 \text{ mv}$, D.C. as measured at the terminals of the lamp.

S14.2.5.5 *Aiming.* Each headlamp is aimed prior to a photometry test in accordance with the procedure appropriate to its aiming system. A $\frac{1}{4}^\circ$ reaim is permitted in any direction at any test point to allow for variations in readings between laboratories for all headlamps except a Type F upper beam unit not equipped with a VHAD.

S14.2.5.5.1 *Mechanically aimable headlamps using an external aimer.* The headlamp is aimed mechanically with the aiming plane at the design angle(s) to the photometer axis and the mechanical axis of the headlamp on the photometer axis.

S14.2.5.5.2 *Mechanically aimable headlamps equipped with a VHAD.* The headlamp is aimed mechanically using the VHAD in accordance with the manufacturer's instructions as provided with the vehicle on which the headlamp is intended to be used.

S14.2.5.5.3 *Visually aimable lower beam headlamps-vertical aim.*

S14.2.5.5.3.1 A VOL cutoff headlamp must have the location of the cutoff maximum gradient, as determined by the method of this standard, positioned at 0.4° down from the H-H line.

S14.2.5.5.3.2 A VOR cutoff headlamp must have the location of the cutoff maximum gradient, as determined by the method of this standard, positioned at the H-H line.

S14.2.5.5.4 *Visually aimable lower beam headlamps-horizontal aim.* There must be no adjustment of horizontal aim unless the headlamp is equipped with a horizontal VHAD. If the headlamp has a VHAD, it must be set to zero.

S14.2.5.5.5 *Visually aimable upper beam headlamps-vertical aim.*

S14.2.5.5.5.1 A headlamp whose upper beam is combined with a lower beam must not have its vertical aim changed from that set for the lower beam.

S14.2.5.5.5.2 A headlamp whose upper beam is not combined with a lower beam must have its maximum beam intensity positioned on the H-H axis.

S14.2.5.5.6 *Visually aimable upper beam headlamps-horizontal aim.*

S14.2.5.5.6.1 A headlamp whose upper beam is combined with a lower beam must not have its horizontal aim

changed from that set for the lower beam.

S14.2.5.5.6.2 A headlamp whose upper beam is not combined with a lower beam and has a fixed horizontal aim or has a horizontal VHAD must be mounted in its normal operating position on a goniometer such that the mounting fixture alignment axes are coincident with the goniometer axes and must be energized at $12.8 \text{ v} \pm 20 \text{ mv}$. There must be no adjustment, shimming, or modification of the horizontal axis of the headlamp or test fixture, unless the headlamp is equipped with a VHAD, in which case the VHAD must be adjusted to zero.

S14.2.5.5.6.3 A headlamp whose upper beam is not combined with a lower beam and is not equipped with a horizontal VHAD, the horizontal aim must be adjusted so that the maximum beam intensity is positioned on the V-V axis.

S14.2.5.5.7 *Simultaneous aim Type F sealed beam headlamps and beam contributor integral beam headlamps.*

S14.2.5.5.7.1 A headlamp system permitted to use simultaneous aim of lower beams and upper beams must be aimed mechanically for lower beam photometry by centering the lower beam unit or the geometric center of all lower beam contributors on the photometer axis and aligning the aiming plane, aiming reference plane, or other appropriate vertical plane defined by the manufacturer perpendicular to the photometer axis.

S14.2.5.5.7.2 The headlamp must be aimed for upper beam photometry by moving the assembly in a plane parallel to the established lower beam aiming plane until the upper beam unit or the geometric center of all upper beam contributors is centered in the photometric axis.

S14.2.5.5.8 *Motorcycle headlamp-upper beam headlamps designed to comply with Table XX.* The upper beam of a multiple beam headlamp designed to comply with the requirements of Table XX must be aimed photoelectrically so that the center of the zone of highest intensity falls 0.4° vertically below the lamp axis and is centered laterally. The center of the zone of highest intensity must be established by the intersection of a horizontal plane passing through the point of maximum intensity, and the vertical plane established by balancing the photometric values at 3°L and 3°R .

S14.2.5.5.9 *Motorcycle headlamp-lower beam headlamps designed to comply with Table XX.* The beam from a single beam headlamp designed to comply with the requirements of Table XX must be aimed straight ahead with

the top of the beam aimed vertically to obtain 2000 cd at H-V.

S14.2.5.6 *Positioner.* The goniometer configuration, used to position the sample headlamp when making photometric measurements at specific angular test points, is horizontal rotation over elevation. The vertical axis of the goniometer must correspond to the design position vertical axis of the sample headlamp which is vertical and perpendicular to the longitudinal axis of the vehicle.

S14.2.5.7 *Photometer.*

S14.2.5.7.1 The photometer must be capable of measuring the luminous intensity of the sample headlamp throughout its illumination range.

S14.2.5.7.2 *Sensor.*

S14.2.5.7.2.1 The maximum effective area of the photometric sensor must fit within a circle whose diameter is equal to 0.009 times the actual test distance from the light source of the sample headlamp to the sensor.

S14.2.5.7.2.2 The sensor effective area is defined as the actual area of intercepted light striking the detector surface of the photometer. Sensor systems incorporating lens(es) that change the diameter of the intercepted light beam before it reaches the actual detector surface, the maximum size requirements must apply to the total area of the light actually intercepted by the lens surface.

S14.2.5.7.2.3 The sensor must be capable of intercepting all direct illumination from the largest illuminated dimension of the sample lamp at the test distance.

S14.2.5.7.3 The color response of the photometer must be corrected to that of the 1931 International Commission on Illumination (C.I.E.) Standard Observer (2-degree) Photopic Response Curve, as shown in the *C.I.E. 1931 Chromaticity Diagram* (incorporated by reference, see 571.108 S5.2 of this title).

S14.2.5.8 *Location of test points.*

S14.2.5.8.1 Test point positions are defined by the positioner. The following nomenclature applies:

S14.2.5.8.1.1 The letters "V" and "H" designate the vertical and horizontal planes intersecting both the headlamp light source and the photometer axis. "H-V" designates the zero test point angle at the intersection of the H and V planes. This intersection is parallel to the longitudinal axis of the vehicle.

S14.2.5.8.1.2 The letters "U", "D", "L", and "R", indicating up, down, left and right, respectively, designate the angular position from the H and V planes to the photometer as viewed from the headlamp.

S14.2.5.8.1.3 Horizontal angles designated L and R are defined as the plan view angle between the vertical plane and the projection of the light ray from the headlamp onto the horizontal plane.

S14.2.5.8.1.4 Vertical angles designated U and D are defined as the true angle between the horizontal plane and the light ray from the headlamp.

S14.2.5.9 *Beam contributor photometry measurements.* In a headlighting system where there is more than one beam contributor providing a lower beam, and/or more than one beam contributor providing an upper beam, each beam contributor must be designed to meet only the applicable photometric performance requirements based upon the following mathematical expression: conforming test point value = $2(\text{test point value})/\text{total number of lower or upper beam contributors for the vehicle, as appropriate.}$

S14.2.5.10 *Moveable reflector aimed headlamp photometry measurements.*

S14.2.5.10.1 A headlamp aimed by moving the reflector relative to the lens and headlamp housing, or vice versa, must conform to the photometry requirements applicable to it with the lens at any position relative to the reflector.

S14.2.5.10.2 These positions include not less than the full range of vertical pitch of the vehicle on which the headlamp is installed and not less than $\pm 2.5^\circ$ from the nominal horizontal aim position for the vehicle on which the headlamp is installed unless the headlamp is visually/optically aimed with a fixed horizontal aim.

S14.3 *Motorcycle headlamp out of focus test procedure and performance requirements.*

S14.3.1 *Procedure.* The sample device must be tested for photometry using bulbs having each of four out-of-focus filament positions. Where conventional bulbs with two pin bayonet bases are used, tests must be made with the light source 0.060 in above, below, ahead, and behind the designated position. If prefocused bulbs are used, the limiting positions at which tests are made must be 0.020 in above, below, ahead, and behind the designated position. The sample device may be re-aimed for each of the out-of-focus positions of the light source.

S14.3.2 *Performance requirements.* The minimum photometric values for the out-of-design position must be 80% of the in-design position.

S14.4 *General test procedures and performance requirements.*

S14.4.1 *Color test.* The requirement applies to the overall effective color of light emitted by the device and not to

the color of the light from a small area of the lens. It does not apply to any pilot, indicator, or tell-tale lights. The color of the sample device must comply when tested by either the Visual Method or the Tristimulus Method.

S14.4.1.1 *Samples.* A test sample for a reflex reflector may be either the reflex reflector or a disc of the same material, technique of fabrication, and dye formulation as the reflex reflector. If a disc is used, the thickness must be twice the thickness of the reflector as measured from the face of the lens to the apexes of the reflecting elements.

S14.4.1.2 *General procedure.*

S14.4.1.2.1 The device must be operated at design voltage.

S14.4.1.2.2 Components (bulbs, caps, lenses, and the like) must be tested in a fixture or manner simulating the intended application.

S14.4.1.2.3 The lamp shall be allowed to reach operating temperature before measurements are made.

S14.4.1.2.4 The entire light emitting surface of the sample must be visible from any point on the entrance window of the test instrument.

S14.4.1.2.5 The distance between the test instrument and the sample must be large enough so that further increases in distance will not affect the results.

S14.4.1.3 *Visual method.*

S14.4.1.3.1 *Visual method procedure.* The color of light from the sample device must be compared visually with the color of the light from a standard. The standard may consist of a filter or limit glass. In the case of white, CIE Source A is used only as a color reference. The chromaticity coordinates of the color standards must be as close as possible to the limits listed. The color of the standard filters is determined spectrophotometrically.

S14.4.1.3.2 *Visual method performance requirements.* The color must comply with the applicable requirement.

S14.4.1.3.2.1 *Red.* Red is not acceptable if it is less saturated (paler), yellower, or bluer than the limit standards.

S14.4.1.3.2.2 *Yellow (Amber).* Yellow is not acceptable if it is less saturated (paler), greener, or redder than the limit standards.

S14.4.1.3.2.3 *White.* White is not acceptable if its color differs materially from that of CIE Source A.

S14.4.1.4 *Tristimulus method.*

S14.4.1.4.1 *Tristimulus method procedure.*

S14.4.1.4.1.1 The color of light from the H-V point of a sample device must be measured by photoelectric receivers with spectral responses that approximate CIE standard spectral tristimulus values.

S14.4.1.4.1.2 A sphere may be used to integrate light from a colored source provided that the color shift that results from the spectral selectivity of the sphere paint be corrected by the use of a filter, correction factor, or an appropriate calibration.

S14.4.1.4.1.3 Where the sample device does not have uniform spectral characteristics in all useful directions, color measurements must be made at as many directions of view as are required to evaluate the color for those directions that apply to the end use of the device.

S14.4.1.4.2 *Tristimulus method performance requirements.* The color must comply with the applicable requirement.

S14.4.1.4.2.1 *Red.* The color of light emitted must fall within the following boundaries:

$$y = 0.33 \text{ (yellow boundary)}$$

$$y = 0.98 - x \text{ (purple boundary)}$$

S14.4.1.4.2.2 *Yellow (Amber).* The color of light emitted must fall within the following boundaries:

$$y = 0.39 \text{ (red boundary)}$$

$$y = 0.79 - 0.67x \text{ (white boundary)}$$

$$y = x - 0.12 \text{ (green boundary)}$$

S14.4.1.4.2.3 *White (achromatic).* The color of light emitted must fall within the following boundaries:

$$x = 0.31 \text{ (blue boundary)}$$

$$y = 0.44 \text{ (green boundary)}$$

$$x = 0.50 \text{ (yellow boundary)}$$

$$y = 0.15 + 0.64x \text{ (green boundary)}$$

$$y = 0.38 \text{ (red boundary)}$$

$$y = 0.05 + 0.75x \text{ (purple boundary)}$$

S14.4.2 *Plastic optical materials tests.* Accelerated weathering procedures are not permitted.

S14.4.2.1 *Samples.*

S14.4.2.1.1 Samples of materials shall be injection molded into polished metal molds to produce test specimens with two flat and parallel faces. Alternative techniques may be used to produce equivalent specimens.

S14.4.2.1.2 Test specimens shape may vary, but each exposed surface must contain a minimum uninterrupted area of 32 sq cm.

S14.4.2.1.3 Samples must be furnished in thicknesses of 1.6 ± 0.25 mm, 2.3 ± 0.25 mm, 3.2 ± 0.25 mm, and 6.4 ± 0.25 mm.

S14.4.2.1.4 All samples must conform to the applicable color test requirement of this standard prior to testing.

S14.4.2.1.5 A control sample, kept properly protected from influences which may change its appearance and properties of each thickness, must be retained.

S14.4.2.2 *Outdoor exposure test.*

S14.4.2.2.1 Outdoor exposure tests of 3 years in duration must be made on

samples of all materials, including coated and uncoated versions, used for optical parts of devices covered by this standard. Tests are to be conducted in Florida and Arizona.

S14.4.2.2.2 Concentrations of polymer components and additives used in plastic materials may be changed without outdoor exposure testing provided the changes are within the limits of composition represented by higher and lower concentrations of these polymer components and additives previously tested to this section and found to meet its requirements.

S14.4.2.2.3 *Procedure.*

S14.4.2.2.3.1 One sample of each thickness of each material must be mounted at each exposure site so that at least a minimum uninterrupted area of 32 sq cm of the exposed upper surface of the sample is at an angle of 45° to the horizontal facing south. The sample must be mounted in the open no closer than 30 cm (11.8 in) to its background.

S14.4.2.2.3.2 During the exposure time the samples must be cleaned once every three months by washing with mild soap or detergent and water, and then rinsing with distilled water. Rubbing must be avoided.

S14.4.2.2.4 *Performance requirements.* Plastic lenses, other than those incorporating reflex reflectors, used for inner lenses or those covered by another material and not exposed directly to sunlight must meet the optical material test requirements when covered by the outer lens or other material.

S14.4.2.2.4.1 After completion of the outdoor exposure test the haze and loss of surface luster as measured by ASTM 1003–92, *Haze and Luminous Transmittance of Transparent Plastic*, (incorporated by reference, see 571.108 S5.2 of this title) must not be greater than:

(a) 30% for materials used for outer lenses, other than those incorporating reflex reflectors;

(b) 7% for materials used for reflex reflectors and lenses used in front of reflex reflectors.

S14.4.2.2.4.2 After completion of the outdoor exposure test materials used for headlamp lenses must show no deterioration.

S14.4.2.2.4.3 After completion of the outdoor exposure test all materials, when compared with the unexposed control samples, must not show physical changes affecting performance such as color bleeding, delamination, crazing, or cracking. Additionally materials used for reflex reflectors and lenses used in front of reflex reflectors

must not show surface deterioration or dimensional changes.

S14.4.2.2.4.4 After completion of the outdoor exposure test all materials, when compared with the unexposed control samples, must not have their luminous transmittance changed by more than 25% when tested in accordance with ASTM E 308–66 (1973), *Spectrophotometry and Description of Color in CIE 1931 System* (incorporated by reference, see 571.108 S5.2 of this title) using CIE Illuminant A (2856K).

S14.4.2.2.4.5 After completion of the outdoor exposure test all materials must conform to the color test of this standard in the range of thickness stated by the material manufacturer.

S14.4.2.3 Heat test.

S14.4.2.3.1 *Procedure.* Two samples of each thickness of each material must be supported at the bottom, with at least 51 mm of the sample above the support, in the vertical position in such a manner that, on each side, the minimum uninterrupted area of exposed surface is not less than 3225 sq mm. The samples are placed in a circulating air oven at 79 ± 3 °C for two hours.

S14.4.2.3.2 *Performance requirements.* After completion of the heat exposure and cooling to room ambient temperature, a test specimen must show no change in shape and general appearance discernable to the naked eye when compared with an unexposed specimen and continue to conform to the applicable color test requirement of this standard.

S14.5 *Signal lamp and reflective device physical test procedures and performance requirements.*

S14.5.1 Vibration test.

S14.5.1.1 *Procedure.* The sample device, as mounted on the support supplied, must be bolted to the anvil end of the table of the vibration test machine of Figure 21 and vibrated approximately 750 cpm through a distance of $\frac{1}{8}$ in. The table must be spring mounted at one end and fitted with steel calks on the underside of the other end. The calks are to make contact with the steel anvil once during each cycle at the completion of the fall. The rack must be operated under a spring tension of 60 to 70 lb. The test must be continued for 1 hour.

S14.5.1.2 *Performance requirements.* After completion of the vibration test a device showing evidence of material physical weakness, lens or reflector rotation, displacement or rupture of parts except bulb failures, must be considered to have failed, providing that the rotation of lens or reflector must not be considered as a failure when tests

show compliance with specifications despite such rotation.

S14.5.2 Moisture test.

S14.5.2.1 *Procedure.* The sample device must be mounted in its normal operating position with all drain holes open and subjected to a precipitation of 0.1 in of water per minute, delivered at an angle of 45° from a nozzle with a solid cone spray. During the test the device must revolve about its vertical axis at a rate of 4 rpm for a period of 12 hours followed by a one hour drain period where the device does not rotate and the spray stops. After completion of the moisture test the device must be examined for moisture accumulation.

S14.5.2.2 *Performance requirements.* Accumulation of moisture in excess of 2 cc or any visible moisture in a sealed reflex unit must constitute a failure.

S14.5.3 Dust test.

S14.5.3.1 *Samples.* A sealed unit is not required to meet the requirements of this test.

S14.5.3.2 *Procedure.* The sample device with any drain hole closed must be mounted in its normal operating position, at least 6 in from the wall in a cubical box with inside measurements of 3 ft on each side containing 10 lb of fine powered cement in accordance with ASTM C 150–56, *Standard Specification for Portland Cement* (incorporated by reference, see 571.108 S5.2 of this title). At intervals of 15 minutes during a test period of 5 hours, the dust must be agitated by compressed air or fan blower by projecting blasts of air for a 2 second period in a downward direction into the dust in such a way that the dust is completely and uniformly diffused throughout the entire cube and allowed to settle. After the completion of the dust test the exterior surface of the device must be cleaned.

S14.5.3.3 *Performance requirements.* If after a photometry test the maximum photometric intensity of the device is not more than 10% less than the maximum photometric intensity of the same device after being cleaned both inside and outside, the device is considered to have met the requirements of the dust test.

S14.5.4 Corrosion test.

S14.5.4.1 *Procedure.* The sample device must be subjected to a salt spray (fog) test in accordance with the latest version of ASTM B117–73, *Method of Salt Spray (Fog) Testing* (incorporated by reference, see 571.108 S5.2 of this title), for a period of 50 hours, consisting of two periods of 24 hour exposure followed by a 1 hr drying time.

S14.5.4.2 *Performance requirements.* After the completion of the corrosion test there must be no evidence of

excessive corrosion which would affect the proper function of the device.

S14.6 *Headlamp physical test procedures and performance requirements.*

S14.6.1 Abrasion test.

S14.6.1.1 Procedure.

S14.6.1.1.1 *Abrading pad.* A new, unused abrading pad constructed of 0000 steel wool not less than $2.5 \pm .1$ cm wide, rubber cemented to a rigid base shaped to the same vertical contour of the lens, is used for each test. The abrading pad support is equal in size to the pad and the center of the support surface is within ± 2 mm of parallel to the lens surface. The “grain” of the pad is oriented perpendicular to the direction of motion. The density of the pad is such that when the pad is resting unweighted on the lens, the base of the pad is no closer than 3.2 mm to the lens at its closest point.

S14.6.1.1.2 Abrading pad alignment.

A sample headlamp is mounted in the abrasion test fixture of Figure 5 with the lens facing upward. When mounted on its support and resting on the lens of the test headlamp, the abrading pad is then weighted such that a pad pressure of 14 ± 1 kPa, exists at the center and perpendicular to the face of the lens.

S14.6.1.1.3 Abrasion test procedure.

The pad is cycled back and forth (1 cycle) for 11 cycles at 4 ± 0.8 in (10 ± 2 cm) per second over at least 80% of the lens surface, including all the area between the upper and lower aiming pads, but not including lens trim rings and edges. A pivot must be used if it is required to follow the contour of the lens.

S14.6.1.2 Performance requirements.

After completion of the abrasion test the sample headlamp must meet the requirements of the applicable photometry tests of Table XIX and Table XVIII. A $\frac{1}{4}$ ° reaim is permitted in any direction at any test point.

S14.6.2 Chemical resistance test.

S14.6.2.1 Procedure.

S14.6.2.1.1 *Test fluids.* The five test fluids used in the chemical resistance test include:

(a) ASTM Reference Fuel C, which is composed of Isooctane 50% volume and Toluene 50% volume. Isooctane must conform to A2.7 in Annex 2 of the Motor Fuels Section of the 1985 Annual Book of ASTM Standards, Vol. 05.04 (incorporated by reference, see 571.108 S5.2 of this title), and Toluene must conform to ASTM specification D362–84, *Standard Specification for Industrial Grade Toluene* (incorporated by reference, see 571.108 S5.2 of this title). ASTM Reference Fuel C must be used as specified in: Paragraph A2.3.2 and A2.3.3 of Annex 2 to Motor Fuels;

Section 1 in the 1985 Annual Book of ASTM Standards, Vol. 05.04 (incorporated by reference, see 571.108 S5.2 of this title); and OSHA Standard 29 CFR 1910.106—Handling Storage and Use of Flammable Combustible Liquids;

(b) Tar remover (consisting by volume of 45% xylene and 55% petroleum base mineral spirits);

(c) Power steering fluid (as specified by the vehicle manufacturer for use in the motor vehicle on which the headlamp is intended to be installed);

(d) Windshield washer fluid consisting of 0.5% monoethanolamine with the remainder 50% concentration of methanol/distilled water by volume; and

(e) Antifreeze (50% concentration of ethylene glycol/distilled water by volume).

S14.6.2.1.2 Fluid application. The entire exterior lens surface of the sample headlamp mounted in the headlamp test fixture and top surface of the lens-reflector joint is wiped once to the left and once to the right with a 6 inch square soft cotton cloth (with pressure equally applied) which has been saturated once in a container with 2 ounces of five different test fluids listed above. The lamp is wiped within 5 seconds after removal of the cloth from the test fluid. A new lamp sample may be used with each fluid.

S14.6.2.1.3 Test duration. After the headlamp sample has been wiped with the test fluid, it must be stored in its designed operating attitude for 48 hours at a temperature of $23^{\circ}\text{C} \pm 4^{\circ}\text{C}$ and a relative humidity of $30\% \pm 10\%$. At the end of the 48-hour period, the headlamp is wiped clean with a soft dry cotton cloth and visually inspected.

S14.6.2.2 Performance requirements. After completion of the chemical resistance test, the sample headlamp must have no surface deterioration, coating delamination, fractures, deterioration of bonding or sealing materials, color bleeding, or color pickup visible without magnification and the headlamp must meet the requirements of the applicable photometry tests of Table XIX and Table XVIII. A $\frac{1}{4}^{\circ}$ reaim is permitted in any direction at any test point.

S14.6.3 Corrosion test.

S14.6.3.1 Procedure. A sample headlamp, mounted on a headlamp test fixture in designed operating position and including all accessory equipment necessary to operate in its normal manner, is subjected to a salt spray (fog) test in accordance with ASTM B117-73, *Method of Salt Spray (Fog) Testing* (incorporated by reference, see 571.108 S5.2 of this title), for 50 total hours,

consisting of two periods of 24 hours exposure followed by a 1 hour drying period. If a portion of the device is completely protected in service, that portion is covered to prevent salt fog entry during exposure. After removal from the salt spray and the final 1 hour drying period the sample headlamp is examined for corrosion that affect any other applicable tests contained in S14.6. If such corrosion is found, the affected test(s) must be performed on the corrosion sample and the results recorded.

S14.6.3.2 Performance requirements. After completion of the corrosion test, the sample headlamp must not have any observed corrosion which would result in the failure of any other applicable tests contained in S14.6 and no corrosion of the headlamp mounting and aiming mechanism that would result in the failure of the aiming adjustment tests, inward force test, or torque deflection test of S14.6.

S14.6.4 Corrosion-connector test.

S14.6.4.1 Procedure.

S14.6.4.1.1 A headlamp connector test must be performed on each filament circuit of the sample headlamp prior to the test in S14.6.4.1.2 according to Figure 4 and S14.6.15. The power source is set to provide 12.8 volts and the resistance must be set to produce 10 amperes.

S14.6.4.1.2 The headlamp, with connector attached to the terminals, unfixed and in its designed operating attitude with all drain holes, breathing devices or other designed openings in their normal operating positions, is subjected to a salt spray (fog) test in accordance with ASTM B117-73, *Method of Salt Spray (Fog) Testing* (incorporated by reference, see 571.108 S5.2 of this title), for 240 hours, consisting of ten successive 24-hour periods.

S14.6.4.1.3 During each period, the headlamp is mounted in the middle of the chamber and exposed for 23 hours to the salt spray. The spray is not activated during the 24th hour. The bulb is removed from the headlamp and from the test chamber during the one hour of salt spray deactivation and reinserted for the start of the next test period, at the end of the first and last three 23-hour periods of salt spray exposure, and at the end of any two of the fourth through seventh 23-hour periods of salt-spray exposure.

S14.6.4.1.4 The test chamber is closed at all times except for a maximum of 2 minutes which is allowed for removal or replacement of a bulb during each period.

S14.6.4.1.5 After the ten periods, the lens-reflector unit without the bulb

must be immersed in deionized water for 5 minutes, then secured and allowed to dry by natural convection only.

S14.6.4.1.6 Using the voltage, resistance and pre-test set up of S14.6.4.1.1 the current in each filament circuit must be measured after the test conducted in S14.6.4.1.2.

S14.6.4.2 Performance requirements.

S14.6.4.2.1 After the completion of the corrosion-connector test, the sample headlamp must show no evidence of external or internal corrosion or rust visible without magnification.

S14.6.4.2.2 Loss of adhesion of any applied coating must not occur more than 3.2 mm from any sharp edge on the inside or out.

S14.6.4.2.3 Corrosion may occur on terminals only if the test current produced during the test of S14.6.4.1.6 is not less than 9.7 amperes.

S14.6.5 Dust test.

S14.6.5.1 Procedure.

S14.6.5.1.1 A sample headlamp, mounted on a headlamp test fixture, with all drain holes, breathing devices or other designed openings in their normal operating positions, is positioned within a cubical box, with inside measurements of 900 mm on each side or larger if required for adequate wall clearance (*i.e.*, a distance of at least 150 mm between the headlamp and any wall of the box).

S14.6.5.1.2 The box contains 4.5 kg of fine powdered cement which conforms to the ASTM C150-77, *Standard Specification for Portland Cement* (incorporated by reference, see 571.108 S5.2 of this title). Every 15 minutes, the cement is agitated by compressed air or fan blower(s) by projecting blasts of air for a two-second period in a downward direction so that the cement is diffused as uniformly as possible throughout the entire box.

S14.6.5.1.3 This test is continued for five hours after which the exterior surfaces of the headlamp are wiped clean.

S14.6.5.2 Performance requirements.

After completion of the dust test, the sample headlamp must meet the requirements of the applicable photometry tests of Table XIX and Table XVIII. A $\frac{1}{4}^{\circ}$ reaim is permitted in any direction at any test point.

S14.6.6 Temperature cycle test and internal heat test.

S14.6.6.1 Samples. A sample headlamp with one or more replaceable light sources is tested according to the procedures of this section for a temperature cycle test and an internal heat test. The same sample headlamp is used in the temperature cycle test and then in the internal heat test.

S14.6.6.2 General procedure.

S14.6.6.2.1 Tests are made with all filaments lighted at design voltage that are intended to be used simultaneously in the headlamp and which in combination draw the highest total wattage. These include but are not limited to filaments used for turn signal lamps, fog lamps, parking lamps, and headlamp lower beams lighted with upper beams when the wiring harness is so connected on the vehicle.

S14.6.6.2.2 If a turn signal is included in the headlamp assembly, it is operated at 90 flashes a minute with a $75\% \pm 2\%$ current "on time."

S14.6.6.2.3 If the lamp produces both the upper and lower beam, it is tested in both the upper beam mode and the lower beam mode under the conditions above described, except for a headlamp with a single type HB1 or type HB2 light source.

S14.6.6.3 *Temperature cycle test.*

S14.6.6.3.1 *Procedure.*

S14.6.6.3.1.1 A sample headlamp, mounted on a headlamp test fixture, is subjected to 10 complete consecutive cycles having the thermal cycle profile shown in Figure 6.

S14.6.6.3.1.2 During the hot cycle, the lamp, is energized commencing at point "A" of Figure 6 and de-energized at point "B."

S14.6.6.3.1.3 Separate or single test chambers may be used to generate the environment of Figure 6.

S14.6.6.3.1.4 All drain holes, breathing devices or other openings or vents of the headlamps are set in their normal operating positions.

S14.6.6.3.2 *Performance requirements.* After completion of the temperature cycle test, the sample headlamp must:

(a) show no evidence of delamination, fractures, entry of moisture, or deterioration of bonding material, color bleeding, warp or deformation visible without magnification;

(b) show no lens warpage greater than 3 mm when measured parallel to the optical axis at the point of intersection of the axis of each light source with the exterior surface of the lens; and

(c) meet the requirements of the applicable photometry tests of Table XIX and Table XVIII. A $\frac{1}{4}^\circ$ reaim is permitted in any direction at any test point.

S14.6.6.4 *Internal heat test.*

S14.6.6.4.1 *Procedure.*

S14.6.6.4.1.1 A sample headlamp lens surface that would normally be exposed to road dirt is uniformly sprayed with any appropriate mixture of dust and water or other materials to reduce the photometric output at the H-V test point of the upper beam (or the $\frac{1}{2}^\circ\text{D}-1\frac{1}{2}^\circ\text{R}$ test point of the lower beam

as applicable) to $25\% \pm 2\%$ of the output originally measured in the applicable photometric compliance test.

S14.6.6.4.1.2 A headlamp with a single type HB1 or type HB2 light source is tested on the upper beam only.

S14.6.6.4.1.3 Such reduction is determined under the same conditions as that of the original photometric measurement.

S14.6.6.4.1.4 After the photometric output of the lamp has been reduced as specified above, the sample lamp and its mounting hardware must be mounted in an environmental chamber in a manner similar to that indicated in Figure 7 "Dirt/Ambient Test Setup."

S14.6.6.4.1.5 The headlamp is soaked for one hour at a temperature of $35^\circ + 4^\circ - 0^\circ\text{C}$ and then the lamp is energized according to the procedure of this section for one hour in a still air condition, allowing the temperature to rise from the soak temperature.

S14.6.6.4.1.6 At the end of one hour the sample lamp is returned to a room ambient temperature of $23^\circ + 4^\circ - 0^\circ\text{C}$ and a relative humidity of $30\% \pm 10\%$ and allowed to stabilize to the room ambient temperature. The lens is then cleaned.

S14.6.6.4.2 *Performance requirements.* After completion of the temperature cycle test and meeting its requirements, and completion of the internal heat test, the sample headlamp must:

(a) have no lens warpage greater than 3 mm when measured parallel to the optical axis at the point of intersection of the axis of each light source with the exterior surface of the lens, and

(b) meet the requirements of the applicable photometry tests of Table XIX and Table XVIII. A $\frac{1}{4}^\circ$ reaim is permitted in any direction at any test point.

S14.6.7 *Humidity test.*

S14.6.7.1 *Procedure.*

S14.6.7.1.1 The test fixture consists of a horizontal steel plate to which three threaded steel or aluminum rods of $\frac{1}{2}$ inch diameter are screwed vertically behind the headlamp.

S14.6.7.1.2 The sample headlamp assembly is clamped to the vertical rods, which are behind the headlamp. All attachments to the headlamp assembly are made behind the lens and vents or openings, and are not within 2 inches laterally of a vent inlet or outlet.

S14.6.7.1.3 The mounted headlamp assembly is oriented in its design operating position, and is placed in a controlled environment at a temperature of $100^\circ + 7^\circ - 0^\circ\text{F}$ ($38^\circ + 4^\circ - 0^\circ\text{C}$) with a relative humidity of not less than 90%. All drain holes, breathing devices, and other openings are set in their

normal operation positions for all phases of the humidity test.

S14.6.7.1.4 The headlamp is subjected to 24 consecutive 3-hour test cycles. In each cycle, the headlamp is energized for 1 hour at design voltage with the highest combination of filament wattages that are intended to be used, and then de-energized for 2 hours. If the headlamp incorporates a turn signal then the turn signal flashes at 90 flashes per minute with a $75\% \pm 2\%$ current "on-time."

S14.6.7.1.5 Within 3 minutes after the completion of the 24th cycle, the air flow test will begin. The following procedure shall occur: the mounted assembly is removed, placed in an insulating box and covered with foam material so that there is no visible air space around the assembly; the box is closed, taken to the air flow test chamber, and placed within it. Inside the chamber, the assembly with respect to the air flow, is oriented in its design operating position. The assembly is positioned in the chamber so that the center of the lens is in the center of the opening of the air flow entry duct during the test. The headlamp has at least 3 inches clearance on all sides, and at least 4 inches to the entry and exit ducts at the closest points. If vent tubes are used which extend below the lamp body, the 3 inches are measured from the bottom of the vent tube or its protection. The temperature of the chamber is $73^\circ + 7^\circ - 0^\circ\text{F}$ ($23^\circ + 4^\circ - 0^\circ\text{C}$) with a relative humidity of $30\% + 10\% - 0\%$. The headlamp is not energized.

S14.6.7.1.6 Before the test specified in paragraph S14.6.7.1.7 of this section, the uniformity of the air flow in the empty test chamber at a plane 4 inches downstream of the air entry duct is measured over a 4 inch square grid. The uniformity of air flow at each grid point is $\pm 10\%$ of the average air flow specified in paragraph S14.6.7.1.7 of this section.

S14.6.7.1.7 The mounted assembly in the chamber is exposed, for one hour, to an average air flow of $330 + 0 - 30$ ft/min as measured with an air velocity measuring probe having an accuracy of $\pm 3\%$ in the 330 ft/min range. The average air flow is the average of the velocity recorded at six points around the perimeter of the lens. The six points are determined as follows: At the center of the lens, construct a horizontal plane. The first two points are located in the plane, 1 inch outward from the intersection of the plane and each edge of the lens. Then, trisect the distance between these two points and construct longitudinal vertical planes at the two intermediate locations formed by the

trisection. The four remaining points are located in the vertical planes, one inch above the top edge of the lens, and one inch below the bottom edge of the lens.

S14.6.7.1.8 After one hour, the headlamp is removed and inspected for moisture.

S14.6.7.2 *Performance requirements.* After completion of the humidity test, the sample headlamp must show no evidence of interior delamination or moisture, fogging or condensation visible without magnification.

S14.6.8 *Vibration test.*

S14.6.8.1 *Samples.* The mounting bracket with a sample headlamp installed must not have a resonant frequency in the 10–55 Hz. range.

S14.6.8.2 *Procedure.* The mounted sample headlamp is bolted to the anvil end of the table of the vibration test machine of Figure 21 and vibrated 750 cpm through a distance of 1/8 in. The table is spring mounted at one end and fitted with steel calks on the underside of the other end. The table is of sufficient size to completely contain the test fixture base with no overhang. The calks are to make contact with the steel anvil once during each cycle at the completion of the fall. The rack is operated under a spring tension of 60 to 70 lb. The vibration is applied in the vertical axis of the headlamp as mounted on the vehicle. Bulb filaments are not energized during the test. The test is continued for 1 hour.

S14.6.8.3 *Performance requirements.* After completion of the vibration test, there must be no evidence of loose or broken parts, other than filaments, visible without magnification.

S14.6.9 *Sealing test.*

S14.6.9.1 *Procedure.*

S14.6.9.1.1 An unfixtured sample headlamp in its design mounting position is placed in water at a temperature of $176^{\circ} \pm 5^{\circ} \text{F}$ ($60^{\circ} \pm 3^{\circ} \text{C}$) for one hour. The headlamp is energized in its highest wattage mode, with the test voltage at $12.8 \pm 0.1 \text{V}$ during immersion.

S14.6.9.1.2 The lamp is then de-energized and immediately submerged in its design mounting position into water at $32^{\circ} + 5^{\circ} - 0^{\circ} \text{F}$ ($0^{\circ} + 3^{\circ} - 0^{\circ} \text{C}$). The water is in a pressurized vessel, and the pressure is increased to 10 psi (70 kPa), upon placing the lamp in the water. The lamp must remain in the pressurized vessel for a period of thirty minutes.

S14.6.9.1.3 This entire procedure is repeated for four cycles.

S14.6.9.1.4 Then the lamp is inspected for any signs of water on its interior. During the high temperature portion of the cycles, the lamp is

observed for signs of air escaping from its interior.

S14.6.9.2 *Performance requirements.* After completion of the sealing test, a sample headlamp confirmed to be sealed need not meet the corrosion test, dust test, or humidity test of this Section. If any water is on the interior or air escapes, the lamp is not a sealed lamp.

S14.6.10 *Chemical resistance test of reflectors of replaceable lens headlamps test.*

S14.6.10.1 *Procedure.*

S14.6.10.1.1 *Test fluids.* The three test fluids used in the chemical resistance test include;

(a) Tar remover (consisting by volume of 45% xylene and 55% petroleum base mineral spirits);

(b) Mineral spirits; and

(c) Fluids other than water contained in the manufacturer's instructions for cleaning the reflector.

S14.6.10.1.2 *Fluid application.* With a sample headlamp in the headlamp test fixture and the lens removed, the entire surface of the reflector that receives light from a headlamp light source is wiped once to the left and once to the right with a 6-inch square soft cotton cloth (with pressure equally applied) which has been saturated once in a container with 2 ounces of one of the test fluids listed in S14.6.10.1.1. The lamp is wiped within 5 seconds after removal of the cloth from the test fluid.

S14.6.10.1.3 *Test duration.* After the headlamp has been wiped with the test fluid, it is stored in its designed operating attitude for 48 hours at a temperature of $73^{\circ} \pm 7^{\circ} \text{F}$ ($23^{\circ} \pm 4^{\circ} \text{C}$) and a relative humidity of $30\% \pm 10\%$. At the end of the 48-hour period, the headlamp is wiped clean with a soft dry cotton cloth and visually inspected.

S14.6.10.2 *Performance requirements.* After completion of the chemical resistance test, the sample headlamp must have no surface deterioration, coating delamination, fractures, deterioration of bonding or sealing materials, color bleeding or color pickup visible without magnification and the headlamp must meet the requirements of the applicable photometry tests of Table XIX and Table XVIII. A $\frac{1}{4}^{\circ}$ re-aim is permitted in any direction at any test point.

S14.6.11 *Corrosion resistance test of reflectors of replaceable lens headlamps test.*

S14.6.11.1 *Procedure.*

S14.6.11.1.1 A sample headlamp with the lens removed, unfixtured and in its designed operating attitude with all drain holes, breathing devices or other designed openings in their normal operating positions, must be subjected

to a salt spray (fog) test in accordance with ASTM B117–73, *Method of Salt Spray (Fog) Testing* (incorporated by reference, see 571.108 S5.2 of this title), for 24 hours, while mounted in the middle of the chamber.

S14.6.11.1.2 Afterwards, the headlamp must be stored in its designed operating attitude for 48 hours at a temperature of $73^{\circ} \pm 7^{\circ} \text{F}$ ($23^{\circ} \pm 4^{\circ} \text{C}$) and a relative humidity of $30\% \pm 10\%$ and allowed to dry by natural convection only. At the end of the 48-hour period, the reflector must be cleaned according to the instructions supplied with the headlamp manufacturer's replacement lens, and inspected. The lens and seal must then be attached according to these instructions and the headlamp tested for photometric performance.

S14.6.11.2 *Performance requirements.* After the completion of the corrosion test, the sample headlamp must show no evidence of corrosion or rust visible without magnification on any part of the headlamp reflector that receives light from a headlamp light source, on any metal light or heat shield assembly, or on a metal reflector of any other lamp. The sample headlamp with the replacement lens installed must meet the requirements of the applicable photometry tests of Table XIX and Table XVIII. A $\frac{1}{4}^{\circ}$ re-aim is permitted in any direction at any test point.

S14.6.12 *Inward force test.*

S14.6.12.1 *Procedure.* A sample headlamp mechanism, including the aiming adjusters, must be subjected to an inward force of 222 N directed normal to the headlamp aiming plane and symmetrically about the center of the headlamp lens face.

S14.6.12.2 *Performance requirements.* After the completion of the inward force test, a sample headlamp must not permanently recede by more than 2.5 mm. The aim of the headlamp must not permanently deviate by more than 3.2 mm at a distance of 7.6 m. The aim of any headlamp that is capable of being mechanically aimed by externally applied aiming devices must not change by more than 0.30° .

S14.6.13 *Torque deflection test.*

S14.6.13.1 *Procedure.*

S14.6.13.1.1 The sample headlamp assembly is mounted in designed vehicle position and set at nominal aim ($H=0$, $V=0$).

S14.6.13.1.2 A sealed beam headlamp, except Type G and Type H, is removed from its mounting and replaced by the applicable deflectometer. (Type C and Type D-Figure 18, Type A and Type E-Figure 16, Type B-Figure 17, and Type F-Figure 14).

S14.6.13.1.3 Sealed beam headlamps Type G and Type H have the adapter of Figure 15 and the deflectometer of Figure 14 attached to the headlamp.

S14.6.13.1.4 A torque of 2.25 Nm must be applied to the headlamp assembly through the deflectometer and a reading on the thumbwheel is taken. The torque must be removed and a second reading on the thumbwheel is taken.

S14.6.13.1.5 Headlamps other than sealed beam headlamps must have the downward force used to create the torque applied parallel to the aiming reference plane, through the aiming pads, and displaced forward using a lever arm such that the force is applied on an axis that is perpendicular to the aiming reference plane and originates at the center of the aiming pad pattern (see Figure 3).

S14.6.13.1.6 For headlamps using the aiming pad locations of Group I, the distance between the point of application of force and the aiming reference plane is not less than 168.3 mm plus the distance from the aiming reference plane to the secondary plane, if used.

S14.6.13.1.7 For headlamps using the aiming pad locations of Group II, the distance between the point of application of force and the aiming reference plane is not less than 167.9 mm plus the distance to the secondary plane, if used.

S14.6.13.1.8 For headlamps using the nonadjustable Headlamp Aiming Device Locating Plates for the 146 mm diameter, the 176 mm diameter, and the 92x150 mm sealed beam, the distance between the point of application of force and the aiming plane is not, respectively, less than 177.4 mm, 176.2 mm, and 193.7 mm.

S14.6.13.2 *Performance requirements.* The aim of each sample headlamp must not deviate more than 0.30° when the downward torque is removed.

S14.6.14 *Retaining ring test.*

S14.6.14.1 *Procedure.* A sample headlamp with the minimum flange thickness of: Type A—31.5 mm, Type B—10.1 mm, Type C—11.8 mm, Type D—11.8 mm, Type E—31.5 mm, and Type F—8.6 mm, is secured between the appropriate mounting ring and retaining ring (mounting ring and aiming ring for Type F).

S14.6.14.2 *Performance requirements.* The sample headlamp when secured per the procedure must be held tight enough that it will not rattle.

S14.6.15 *Headlamp connector test.*

S14.6.15.1 *Procedure.* A sample headlamp connected into the test circuit

of Figure 4 has the power supply adjusted until 10 amperes DC are flowing through the circuit. The test is repeated for each filament circuit of the headlamp.

S14.6.15.2 *Performance requirements.* The voltage drop, as measured in the test circuit of Figure 4, must not exceed 40 mv DC in any applicable filament circuit of the sample headlamp.

S14.6.16 *Headlamp wattage test.*

S14.6.16.1 *Procedure.* A sample headlamp that has been seasoned is energized so as to have 12.8v ± 20 mv DC applied across each filament circuit and the current flowing in each circuit is measured.

S14.6.16.2 *Performance requirements.* The wattage of each filament circuit of the sample headlamp must not exceed the applicable value for that type of headlamp as shown in Table II.

S14.6.17 *Aiming adjustment test-laboratory.*

S14.6.17.1 *Procedure.* A sample headlamp is mounted in design position at nominal (H = 0, V = 0) aim with an accurate measuring device such as a spot projector or other equally accurate means attached. The headlamp is adjusted to the extremes of travel in each horizontal and vertical direction.

S14.6.17.2 *Performance requirements.* Visually aimed lower beam headlamps without a VHAD are required not to have a horizontal adjustment mechanism and horizontal aim range requirements do not apply.

S14.6.17.2.1 A sample sealed beam headlamp, other than a Type F, tested per the procedure must provide a minimum of ± 4.0° adjustment range in both the vertical and horizontal planes and if equipped with independent vertical and horizontal aiming screws, the adjustment must be such that neither the vertical nor horizontal aim must deviate more than 100 mm from horizontal or vertical planes, respectively, at a distance of 7.6 m through an angle of ± 4.0°.

S14.6.17.2.2 A sample Type F sealed beam, integral beam, replaceable bulb, or combination headlamp tested per the procedure must provide a minimum of ± 4.0° adjustment range in the vertical plane and ± 2.5° in the horizontal plane and if equipped with independent vertical and horizontal aiming screws, the adjustment must be such that neither the vertical nor horizontal aim must deviate more than 100 mm from horizontal or vertical planes, respectively, at a distance of 7.6 m through an angle of ± 2.5° and ± 4.0°, respectively.

S14.6.17.2.3 A sample headlamp that is aimed by moving the reflector relative to the lens and headlamp housing, and vice versa must provide a minimum adjustment range in the vertical plane not less than the full range of the pitch on the vehicle on which it is installed and ± 2.5° in the horizontal plane.

S14.6.18 *Aiming adjustment test-on vehicle.*

S14.6.18.1 *Procedure.*

S14.6.18.1.1 A sample headlamp is mounted on the vehicle at nominal (H = 0, V = 0) aim with an accurate measuring device such as a spot projector or other equally accurate means attached.

S14.6.18.1.2 The installed range of static pitch angle is, at a minimum, determined from unloaded vehicle weight to gross vehicle weight rating, and incorporates pitch angle effects from maximum trailer or trunk loadings, the full range of tire intermix sizes and suspensions recommended and/or installed by the vehicle manufacturer, and the anticipated effects of variable passenger loading.

S14.6.18.1.3 The headlamp is adjusted to the extremes of travel in each horizontal and vertical direction.

S14.6.18.2 *Performance requirements.*

S14.6.18.2.1 A sample headlamp tested per the procedure must provide a minimum vertical adjustment range not less than the full range of pitch of the vehicle on which it is installed.

S14.6.18.2.2 The vertical aim mechanism must be continuously variable over the full range.

S14.6.18.2.3 The adjustment of one aim axis through its full on-vehicle range must not cause the aim of the other axis to deviate more than ± 0.76°. If this performance is not achievable, the requirements of S10.18.3.1 apply, except that if the aiming mechanism is not a VHAD, the requirements specific to VHADs are not applicable, and the instruction must be specific to the aiming mechanism installed.

S14.7 *Replaceable light source physical test procedures and performance requirements.*

S14.7.1 *Deflection test for replaceable light sources.*

S14.7.1.1 *Procedure.*

S14.7.1.1.1 With the sample light source rigidly mounted in a fixture in a manner indicated in Figure 8, a force 4.0 ± 0.1 pounds (17.8 ± 0.4N) is applied at a distance "A" from the reference plane perpendicular to the longitudinal axis of the glass capsule and parallel to the smallest dimension of the pressed glass capsule seal.

S14.7.1.1.2 The force is applied (using a rod with a hard rubber tip with a minimum spherical radius of .039 in [1 mm]) radially to the surface of the glass capsule in four locations in a plane parallel to the reference plane and spaced at a distance "A" from that plane. These force applications are spaced 90° apart starting at the point perpendicular to the smallest dimension of the pressed seal of the glass capsule.

S14.7.1.1.3. The bulb deflection is measured at the glass capsule surface at 180° opposite to the force application. Distance "A" for a replaceable light source other than an HB Type is the dimension provided in accordance with Appendix A of part 564 of this chapter, section I.A.1 if the light source has a lower beam filament, or as specified in section I.B.1 if the light source has only an upper beam filament.

S14.7.1.2 *Performance requirements.* After completion of the deflection test, a sample light source must have no permanent deflection of the glass envelope exceeding 0.13 mm in the direction of applied force.

S14.7.2 *Pressure test for replaceable light sources.*

S14.7.2.1 *Procedure.*

S14.7.2.1.1 The capsule, lead wires and/or terminals, and seal on each sample Type HB1, Type HB3, Type HB4, and Type HB5 light source, and on any other replaceable light source which uses a seal, is installed in a pressure chamber as shown in Figure 10 so as to provide an airtight seal. The diameter of the aperture in Figure 10 on a replaceable light source (other than an HB Type) must be that dimension furnished for such light source in compliance with Appendix A or Appendix B of part 564 of this chapter.

S14.7.2.1.2 The light source is immersed in water for one minute while inserted in a cylindrical aperture specified for the light source, and subjected to an air pressure of 70 KPa (10 psig) on the glass capsule side.

S14.7.2.2 *Performance requirements.* After completion of the pressure test, the sample light source with an airtight seal on the low pressure (connector side) must show no evidence of air bubbles on that side.

S14.7.3 *Replaceable light source power and flux measurement procedure.* The measurement of maximum power and luminous flux that is submitted in compliance with section VII of Appendix A of part 564 of this chapter, or section IV of Appendix B of part 564 of this chapter, is made in accordance with this paragraph.

S14.7.3.1 *Seasoning.* The filament or discharge arc is seasoned before

measurement of either maximum power and luminous flux.

S14.7.3.1.1 *Resistive filament source.* Seasoning of a light source with a resistive element type filament is made in accordance with this S14.2.5.4 of this standard.

S14.7.3.1.2 *Discharge source.* For a light source using excited gas mixtures as a filament or discharge arc, seasoning of the light source system, including any ballast required for its operation, is made in accordance with section 4.0 of SAE Recommended Practice J2009 FEB93, *Discharge Forward Lighting Systems.*

S14.7.3.2 *Test voltage.* Measurements are made with a direct current test voltage of 12.8 v regulated within one quarter of one percent.

S14.7.3.3 *Luminous flux measurement.* The measurement of luminous flux is made in accordance with the Illuminating Engineering Society of North America, LM 45; IES *Approved Method for Electrical and Photometric Measurements of General Service Incandescent Filament Lamps* (April 1980) (incorporated by reference, see 571.108 S5.2 of this title).

S14.7.3.3.1 *Resistive filament light source setup.* Luminous flux measurements are made with the black cap installed on Type HB1, Type HB2, Type HB4, and Type HB5, and on any other replaceable light source so designed; and is with the electrical conductor and light source base shrouded with an opaque white cover, except for the portion normally located within the interior of the lamp housing. The measurement of luminous flux for the Types HB3 and HB4 is made with the base covered with a white cover as shown in the drawings for Types HB3 and HB4 filed in Docket No. NHTSA 98-3397. The white covers are used to eliminate the likelihood of incorrect lumen measurement that will occur should the reflectance of the light source base and electrical connector be low.

S14.7.3.3.2 *Discharge light source setup.* With the test voltage applied to the ballast input terminals, the measurement of luminous flux is made with the black cap installed, if so designed, and is made with an opaque white colored cover, except for the portion normally located within the interior of the lamp housing.

S14.8 *Vehicle headlamp aiming devices (VHAD) physical test procedures and performance requirements.*

S14.8.1 *Samples.* The same VHAD and associated headlamp(s) or headlamp assembly must be rigidly mounted in a headlamp test fixture with

the aiming plane horizontal and vertical and with the scale on the device set at 0.

S14.8.2 *Scale graduation test.*

S14.8.2.1 *Procedure.* Check each graduation on the horizontal and vertical aim scales.

S14.8.2.2 *Performance requirements.* Scale graduation from correct aim must not exceed $\pm 0.2^\circ$ horizontally and $\pm 0.1^\circ$ vertically.

S14.8.3 *Cold scale graduation test.*

S14.8.3.1 *Procedure.* The VHAD and an unlighted headlamp assembly must then be stabilized at $-7^\circ \pm 3^\circ\text{C}$ in a circulating air environmental test chamber for a 30 minute temperature soak.

S14.8.3.2 *Performance requirements.* After completion of a 30 minute temperature soak the variation from correct aim shown by the sample VHAD must not exceed $\pm 0.2^\circ$ horizontally and $\pm 0.1^\circ$ vertically.

S14.8.4 *Hot scale graduation test.*

S14.8.4.1 *Procedure.* The VHAD and the headlamp assembly with its highest wattage filament, or combination of filaments intended to be used simultaneously, energized at its design voltage, is then stabilized at $38^\circ \pm 3^\circ\text{C}$ in a circulating air environmental test chamber for a 30 minute temperature soak.

S14.8.4.2 *Performance requirements.* After completion of a 30 minute temperature soak the variation from correct aim shown by the sample VHAD must not exceed $\pm 0.2^\circ$ horizontally and $\pm 0.1^\circ$ vertically.

S14.8.5 *Thermal cycle test.*

S14.8.5.1 *Procedure.* The VHAD and an unlighted headlamp assembly are then placed in a circulating air environmental test chamber and exposed to a temperature of $60^\circ \pm 3^\circ\text{C}$ for 24 hours, followed by a temperature of $-40^\circ \pm 3^\circ\text{C}$ for 24 hours, and are then permitted to return to room temperature.

S14.8.5.2 *Performance requirements.* After completion of the thermal cycle test the variation from correct aim shown by the sample VHAD must not exceed $\pm 0.2^\circ$ horizontally and $\pm 0.1^\circ$ vertically and the VHAD and headlamp assembly must show no damage which would impair its ability to perform as specified in this standard.

S14.8.6 *Corrosion test.*

S14.8.6.1 *Procedure.* The VHAD and headlamp assembly are then tested according to the headlamp corrosion test of S14.6.3.

S14.8.6.2 *Performance requirements.* After completion of the corrosion test the sample VHAD and headlamp must not have any observed corrosion that would result in the failure of any other

applicable tests contained in this section.

S14.8.7 Photometry test.

S14.8.7.1 Procedure. The VHAD and headlamp assembly are then tested for photometric compliance according to the procedure of S14.2.5 and for replacement units per S10.18.8.4.

S14.8.7.2 Performance requirements. The sample headlamp must comply with the applicable photometric requirements of Table XIX and Table XVIII and with replacement units installed per S10.18.8.4.

S14.9 Associated equipment physical test procedures and performance requirements.

S14.9.1 Turn signal operating unit durability test.

S14.9.1.1 Power supply

specifications. During the test, the unit is operated at 6.4 volts for 6 volt systems or 12.8 volts for 12 volt systems from a power supply meeting the following requirements:

- (a) An output current that is at least 10 times the load current;
- (b) Voltage regulation that allows a voltage change of less than 5%;
- (c) Ripple voltage of not more than 5%;
- (d) A response time of not more than 25 milliseconds rise time from 0 to rated current at rated voltage in a pure resistance circuit; and
- (e) An output impedance of not more than 0.005 ohms dc.

S14.9.1.2 Procedure.

S14.9.1.2.1 The sample unit is operated with the maximum bulb load it will experience on the vehicle on which it will be installed. Bulbs that fail during the test are replaced. The turn signal flasher is not to be included in the test circuit. When the unit includes a self-canceling means, the test equipment is arranged so that the unit will be turned "off" in its normal operating manner.

S14.9.1.2.2 The test is conducted at a rate not to exceed 15 complete cycles per minute. One complete cycle consists of the following sequence: Off, left turn, off, right turn, and return to off.

S14.9.1.2.3 The voltage drop from the input terminal of the device to each lamp output terminal, including 3 in of 16 or 18 gage wire, is measured at the start of the test, at intervals of not more than 25,000 cycles during the test, and at the completion of the test.

S14.9.1.3 Performance requirements.

S14.9.1.3.1 A turn signal operating unit is considered to have met the requirements of the durability test if it remains operational after completing at least 100,000 cycles, and the voltage drop between the input contact and any output contact, including required

length of wire, does not exceed 0.25 volts.

S14.9.1.3.2 A turn signal operating unit is considered to have met the requirements of the durability test if it remains operational after completing at least 175,000 cycles for a unit installed on a multipurpose passenger vehicle, truck, or bus 2032 mm or more in overall width, and the voltage drop between the input contact and any output contact, including required length of wire, does not exceed 0.25 volts.

S14.9.1.3.3 If stop signals also operate through the turn signal operating unit, the voltage drop of any additional switch contacts must meet the same requirements as the turn signal contacts.

S14.9.2 Vehicular hazard warning signal operating unit durability test.

S14.9.2.1 Procedure.

S14.9.2.1.1 The sample unit is operated at its rated voltage with the maximum bulb load it will experience on the vehicle on which it will be installed. Bulbs that fail during the test are replaced. The hazard warning signal flasher is not to be included in the test circuit.

S14.9.2.1.2 The unit is turned "on" and "off" in its normal operating manner at a rate not to exceed 15 complete cycles per minute. One complete cycle consists of the sequence: Off, on, and return to off. The test consists of 10,000 cycles at an ambient temperature of $75^{\circ} \pm 10^{\circ}$ F followed by 1 hour constant "on" at the same temperature.

S14.9.2.1.3 The voltage drop from the input terminal of the device to each lamp output terminal, including 3 in of 16 or 18 gage wire, is measured at the start of the test and at the completion of the test.

S14.9.2.2 Performance requirements. A hazard warning signal operating unit is considered to have met the requirements of the durability test if it remains operational after completing 10,000 cycles and the 1 hour constant "on" and the voltage drop between the input contact and any output contact, including required length of wire, does not exceed 0.3 volts for either 6.4 or 12.8 line voltage both at the start and completion of the test.

S14.9.3 Turn signal flasher and vehicular hazard warning signal flasher tests.

S14.9.3.1 Standard test circuit. All turn signal flasher and vehicular hazard warning signal flasher tests use the standard test circuit of Figure 22.

S14.9.3.1.1 Test circuit setup.

S14.9.3.1.1.1 The effective series resistance in the total circuit between

the power supply and the bulb sockets (excluding the flasher and bulb load(s) using shorting bars) is 0.10 ± 0.01 ohm.

S14.9.3.1.1.2 The circuit resistance at A-B of Figure 22 is measured with flasher and bulb load(s) each shorted out with an effective shunt resistance not to exceed 0.005 ohms.

S14.9.3.1.1.3 The voltage to the bulbs at C-D of Figure 22 is adjusted to 12.8 volts (or 6.4 volts) with the flasher shorted out by an effective shunt resistance not to exceed 0.005 ohms. The load current is adjusted by simultaneously adjusting trimmer resistors, R.

S14.9.3.1.1.4 For testing fixed-load flashers at other required voltages, adjust the power supply to provide required voltages, at the required temperatures, at C-D of Figure 22, without readjustment of trimming resistors, R.

S14.9.3.1.1.5 For variable-load flashers, the circuit is first adjusted for 12.8 volts (or 6.4 volts) at C-D of Figure 22, with the minimum required load, and the power supply is adjusted to provide other required test voltages, at required temperatures, at C-D of Figure 22, without readjustment of trimming resistors, R (each such required voltage being set with the minimum required load in place). The required voltage tests with the maximum load are conducted without readjusting each corresponding power supply voltage, previously set with minimum bulb load.

S14.9.3.1.1.6 A suitable high impedance measuring device connected to points X-Y in Figure 22 is used for measuring flash rate, percent current "on" time, and voltage drop across the flasher. The measurement of these quantities does not affect the circuit.

S14.9.3.2 Power supply specifications.

S14.9.3.2.1 Starting time, voltage drop, and flash rate and percent current "on" time tests. The power supply used in the standard test circuit for conducting the starting time, the voltage drop, and the flash rate and percent current "on" time tests must comply with the following specifications:

- (a) Must not generate any adverse transients not present in motor vehicles;
- (b) Be capable of supplying 11–16 vdc for 12 volt flashers and 5–9 vdc for 6 volt flashers to the input terminals of the standard test circuit;
- (c) Be capable of supplying required design current(s) continuously and inrush currents as required by the design bulb load complement;
- (d) Be capable of supplying an output voltage that does not deviate more than 2% with changes in the static load from 0 to maximum (not including inrush

current) nor for static input line voltage variations;

(e) Be capable of supplying an output voltage that does not deviate more than 1.0 vdc from 0 to maximum load (including inrush current) and must recover 63% of its maximum excursion within 100 μ sec; and

(f) Have a ripple voltage of 75mv, peak to peak.

S14.9.3.2.2 Durability tests. The power supply used in the standard test circuit for conducting durability tests must comply with the following specifications:

(a) Must not generate any adverse transients not present in motor vehicles;

(b) Be capable of supplying 13 vdc and 14 vdc for 12 volt flashers and 6.5 vdc and 7 vdc for 6 volt flashers to the input terminals of the standard test circuit;

(c) Be capable of supplying a continuous output current of the design load for one flasher times the number of flashers and inrush currents as required by the design bulb load complement;

(d) Be capable of supplying an output voltage that does not deviate more than 2% with changes in the static load from 0 to maximum (not including inrush current) and means must be provided to compensate for static input line voltage variations;

(e) Be capable of supplying an output voltage that does not deviate more than 1.0 vdc from 0 to maximum load (including inrush current) and must recover 63% of its maximum excursion within 5 μ sec; and

(f) Have a ripple voltage of 300 mv, peak to peak.

S14.9.3.3 Turn signal flasher starting time test.

S14.9.3.3.1 Samples. Twenty sample flashers chosen from random from fifty representative samples are subjected to a starting time test using the standard test circuit.

S14.9.3.3.2 Procedure.

S14.9.3.3.2.1 The test is conducted in an ambient temperature of 75 ± 10 °F with the design load (variable load flashers are tested with their minimum and their maximum design load) connected and the power source for the test circuit adjusted to apply design voltage at the bulbs.

S14.9.3.3.2.2 The time measurement starts when the voltage is initially applied. Compliance is based on an average of three starts for each sample separated by a cooling interval of 5 minutes.

S14.9.3.3.3 Performance requirements. The requirements of the starting time test are considered to have been met if 17 of 20 samples comply with the following:

(a) A flasher having normally closed contacts must open (turn off) within 1.0 second for a device designed to operate two signal lamps, or within 1.25 seconds for a device designed to operate more than two lamps, or

(b) A flasher having normally open contacts must complete the first cycle (close the contacts and then open the contacts) within 1.5 seconds.

S14.9.3.4 Turn signal flasher voltage drop test.

S14.9.3.4.1 Samples. The same twenty sample flashers used in the starting time test are subjected to a voltage drop test using the standard test circuit.

S14.9.3.4.2 Procedure.

S14.9.3.4.2.1 The test is conducted in an ambient temperature of 75 ± 10 °F with the design load (variable load flashers are tested with their maximum design load) connected and the power source for the standard test circuit adjusted to apply 12.8 volts or 6.4 volts at the bulbs according to the flasher rating.

S14.9.3.4.2.2 The voltage drop is measured between the input and load terminals of the flasher during the "on" period after the flashers have completed at least five consecutive cycles.

S14.9.3.4.3 Performance requirements. The requirements of the voltage drop test are considered to have been met if 17 of 20 samples comply with the lowest voltage drop across any flasher not exceeding 0.80 volt.

S14.9.3.5 Turn signal flasher flash rate and percent current "on" time test.

S14.9.3.5.1 Samples. The same twenty sample flashers used in the voltage drop test are subjected to a flash rate and percent of current "on" time test.

S14.9.3.5.2 Procedure.

S14.9.3.5.2.1 The test is conducted using the standard test circuit with the design load (variable load flashers are tested with their minimum and their maximum design load) connected and design voltage applied to the bulbs.

S14.9.3.5.2.2 Compliance is determined using the following combinations of ambient temperature and bulb voltage:

(a) 12.8 volts (or 6.4 volts) and 75 ± 10 °F,

(b) 12.0 volts (or 6.0 volts) and 0 ± 5 °F,

(c) 15.0 volts (or 7.5 volts) and 0 ± 5 °F,

(d) 11.0 volts (or 5.5 volts) and 125 ± 5 °F, and

(e) 14.0 volts (or 7.0 volts) and 125 ± 5 °F.

S14.9.3.5.2.3 Flash rate and percent current "on" time are measured after the flashers have completed five

consecutive cycles and are determined by an average of at least three consecutive cycles.

S14.9.3.5.3 Performance requirements. The requirements of the flash rate and percent current "on" time test are considered to have been met if 17 of 20 samples comply with the following:

(a) The performance of a normally closed type flasher must be within the unshaded portion of the polygon shown in Figure 2, or

(b) The performance of a normally open type flasher must be within the entire rectangle including the shaded areas shown in Figure 2.

S14.9.3.6 Turn signal flasher durability test.

S14.9.3.6.1 Samples. Twenty sample flashers chosen from random from the thirty samples not used in the previous tests are subjected to a durability test.

S14.9.3.6.2 Procedure.

S14.9.3.6.2.1 Conformance of the samples to the starting time, voltage drop, and flash rate and percent of current "on" time tests (limited to the 12.8 volts or 6.4 volts and 75 ± 10 °F test condition only) is established.

S14.9.3.6.2.2 The test is conducted on each sample with the design load (variable load flashers are tested with their maximum design load) connected and 14 volts or 7.0 volts, according to the flasher rating, applied to the input terminals of the standard test circuit.

S14.9.3.6.2.3 The test cycle consists of 15 seconds on followed by 15 seconds off for a total time of 200 hours in an ambient temperature of 75 ± 10 °F.

S14.9.3.6.3 Performance requirements. The requirements of the durability test are considered to have been met if, after completion, 17 of 20 samples comply with the performance requirements of the starting time, voltage drop, and flash rate and percent of current "on" time tests (limited to the 12.8 volts or 6.4 volts and 75 ± 10 °F test condition only) when tested in the standard test circuit with design load and 12.8 volts (or 6.4 volts) applied to the bulbs.

S14.9.3.7 Vehicular hazard warning signal flasher starting time test.

S14.9.3.7.1 Samples. Twenty sample flashers chosen from random from fifty representative samples are subjected to a starting time test using the standard test circuit.

S14.9.3.7.2 Procedure.

S14.9.3.7.2.1 The test is conducted test in an ambient temperature of 75 ± 10 °F with the minimum and maximum load connected and the power source for the test circuit adjusted to apply design voltage at the bulbs.

S14.9.3.7.2.2 The time measurement starts when the voltage is initially applied.

S14.9.3.7.3 *Performance requirements.* The requirements of the starting time test are considered to have been met if 17 of 20 samples comply with the following:

(a) A flasher having normally closed contacts must open (turn off) within 1.5 seconds after the voltage is applied, or

(b) A flasher having normally open contacts must complete the first cycle (close the contacts and then open the contacts) within 1.5 seconds after the voltage is applied.

S14.9.3.8 *Vehicular hazard warning signal flasher voltage drop test.*

S14.9.3.8.1 *Samples.* The same twenty sample flashers used in the starting time test are subjected to a voltage drop test using the standard test circuit.

S14.9.3.8.2 *Procedure.*

S14.9.3.8.2.1 The test is conducted in an ambient temperature of $75^{\circ} \pm 10^{\circ}$ F with the maximum design load connected and the power source for the test circuit adjusted to apply design voltage at the bulbs.

S14.9.3.8.2.2 The voltage drop is measured between the input and load terminals of the flasher during the "on" period after the flashers have completed at least five consecutive cycles.

S14.9.3.8.3 *Performance requirements.* The requirements of the voltage drop test are considered to have been met if 17 of 20 samples comply with the lowest voltage drop across any flasher must not exceed 0.8 volt.

S14.9.3.9 *Vehicular hazard warning signal flasher flash rate and percent "on" time test.*

S14.9.3.9.1 *Samples.* The same twenty sample flashers used in the voltage drop test are subjected to a flash rate and percent of current "on" time test.

S14.9.3.9.2 *Procedure.*

S14.9.3.9.2.1 The test is conducted using the standard test circuit by and applying loads of from two signal lamps to the maximum design loading including pilot indicator.

S14.9.3.9.2.2 Compliance is determined using the following combinations of ambient temperature and bulb voltage:

(a) 12.8 volts (or 6.4 volts) and $75^{\circ} \pm 10^{\circ}$ F,

(b) 11.0 volts (or 5.5 volts) and $125^{\circ} \pm 5^{\circ}$ F,

(c) 11.0 volts (or 5.5 volts) and $0^{\circ} \pm 5^{\circ}$ F,

(d) 13.0 volts (or 6.5 volts) and $125^{\circ} \pm 5^{\circ}$ F, and

(e) 13.0 volts (or 6.5 volts) and $0^{\circ} \pm 5^{\circ}$ F.

S14.9.3.9.2.3 Flash rate and percent current "on" time are measured after the flashers have completed five consecutive cycles and are determined by an average of at least three consecutive cycles.

S14.9.3.9.3 *Performance requirements.* The requirements of the flash rate and percent current "on" time test are considered to have been met if 17 of 20 samples comply with the following:

(a) The performance of a normally closed type flasher must be within the unshaded portion of the polygon shown in Figure 2, or

(b) The performance of a normally open type flasher must be within the entire rectangle including the shaded areas shown in Figure 2.

S14.9.3.10 *Vehicular hazard warning signal flasher durability test.*

S14.9.3.10.1 *Samples.* Twenty sample flashers chosen from random from the thirty samples not used in the previous tests are subjected to a durability test.

S14.9.3.10.2 *Procedure.*

S14.9.3.10.2.1 Conformance of the samples to the starting time, voltage drop, and flash rate and percent of current "on" time tests (limited to the 12.8 volts or 6.4 volts and $75^{\circ} \pm 10^{\circ}$ F test condition only) is established.

S14.9.3.10.2.2 The test is conducted on each sample with the maximum design load connected and 13.0 volts (or 6.5 volts) applied to the input terminals of the standard test circuit.

S14.9.3.10.2.3 The flasher is subjected to continuous flashing for a total time of 36 hours in an ambient temperature of $75^{\circ} \pm 10^{\circ}$ F.

S14.9.3.10.3 *Performance requirements.* The requirements of the durability test are considered to have been met if, after completion, 17 of 20 samples comply with the performance requirements of the starting time, voltage drop, and flash rate and percent of current "on" time tests (limited to the 12.8 volts or 6.4 volts and $75^{\circ} \pm 10^{\circ}$ F test condition only) when tested in the standard test circuit with the power source adjusted to provide design voltage to the bulbs and with a minimum load of two signal lamp bulbs and the maximum design load, including pilot lamps, as specified by the manufacturer at an ambient temperature of $75^{\circ} \pm 10^{\circ}$ F.

S14.9.3.11 *Semiautomatic headlamp beam switching device tests.*

S14.9.3.11.1 *Test conditions.* All tests are conducted with 13 volts input to the device unless otherwise specified.

S14.9.3.11.2 *Sensitivity test.*

S14.9.3.11.2.1 *Samples.* The sample device is mounted in and operated in the laboratory in the same environment as that encountered on the vehicle, that is tinted glass, grille work, etc.

S14.9.3.11.2.2 *Procedure.*

S14.9.3.11.2.2.1 The sample device is adjusted for sensitivity in accordance with the manufacturer's instructions. It is exposed to a light source capable of providing a variable intensity of at least 1.5 cd to 150 cd at 100 feet from the sample device.

S14.9.3.11.2.2.2 The device is switched to the lower beam mode in accordance with the "dim" limits specified and switched back to the upper beam mode in accordance with the "hold" limits specified for the specified test positions.

S14.9.3.11.2.2.3 To provide more complete information on sensitivity throughout the required vertical and horizontal angles, a set of constant footcandle curves are made at "dim" sensitivities of 17, 25, and 100 cd at 100 ft.

S14.9.3.11.2.3 *Performance requirements.*

S14.9.3.11.2.3.1 *Operating limits.*

Test position (degrees)		Dim (cd at 100 ft)	Hold (cd at 100 ft)
H	V	Adjust to 15	1.5 min to 3.75 max.
H	2L	25 max	1.5 min.
H	4L	40 max	1.5 min.
H	6L	75 max	1.5 min.
H	2R	25 max	1.5 min.
H	5R	150 max to 40 min	1.5 min.
1D	V	30 max	1.5 min.
1U	V	30 max	1.5 min.

S14.9.3.11.2.3.2 There must be no sensitivity voids shown in the constant footcandle curves within the area limited by the test positions.

S14.9.3.11.3 *Voltage regulation test.*

S14.9.3.11.3.1 *Procedure.*

S14.9.3.11.3.1.1 The sensitivity of the sample device is adjusted so that it complies with the sensitivity test.

S14.9.3.11.3.1.2 The “dim” sensitivity is measured at the H–V test position at 11 volts input to the device and at 15 volts input to the device.

S14.9.3.11.3.2 *Performance requirements.* The device must switch to the lower beam mode at between 8 (cd at 100 ft) and 25 (cd at 100 ft) with the input voltage at 11 volts and at 15 volts.

S14.9.3.11.4 *Manual override test.*

S14.9.3.11.4.1 *Procedure.*

S14.9.3.11.4.1.1 The sensitivity of the sample device is adjusted so that it complies with the sensitivity test.

S14.9.3.11.4.1.2 The device is exposed to a test light that causes it to switch to the lower beam mode.

S14.9.3.11.4.1.3 The manufacturer’s instructions are followed to cause the device to override the test light and switch to upper beam.

S14.9.3.11.4.1.4 In a similar manner, the test light is extinguished to cause the device to switch to the upper beam mode.

S14.9.3.11.4.1.5 Again the manufacturer’s instructions are followed to cause the device to switch to lower beam.

S14.9.3.11.4.2 *Performance requirements.* The device, when operated in accordance with the manufacturer’s instructions, must switch to the opposite beam with the test light energized and with the test light extinguished.

S14.9.3.11.5 *Warmup test.*

S14.9.3.11.5.1 *Procedure.*

S14.9.3.11.5.1.1 The sensitivity of the sample device is adjusted so that it complies with the sensitivity test and the test lamp extinguished.

S14.9.3.11.5.1.2 The test lamp will then be energized at a level of 25 (cd at 100 ft) at the H–V position of the device and the time for the device to switch to lower beam is measured.

S14.9.3.11.5.2 *Performance requirements.* If the warmup time of the device exceeds 10 seconds it shall maintain the headlamps on lower beam during warmup.

S14.9.3.11.6 *Temperature test.*

S14.9.3.11.6.1 *Procedure.*

S14.9.3.11.6.1.1 The sample device is exposed for 1 hour in a temperature corresponding to that at the device mounting location.

S14.9.3.11.6.1.2 For a device mounted in the passenger compartment

or the engine compartment, the temperature is 210° F, mounted elsewhere, the temperature is 150° F.

S14.9.3.11.6.1.3 After this exposure the H–V “dim” sensitivity of the sample device is measured over the temperature range of –30° F to +100° F.

S14.9.3.11.6.2 *Performance requirements.* The device must switch to the lower beam mode between 8 (cd at 100 ft) and 25 (cd at 100 ft) over the temperature range of –30° F to +100° F.

S14.9.3.11.7 *Dust test.*

S14.9.3.11.7.1 *Procedure.*

S14.9.3.11.7.1.1 The sensitivity of the sample device is adjusted so that it complies with the sensitivity test.

S14.9.3.11.7.1.2 The device is then subjected to the dust test of S14.5.3.

S14.9.3.11.7.1.3 At the conclusion of the dust exposure the lens of the device must be wiped clean and the H–V “dim” sensitivity of the sample device is measured.

S14.9.3.11.7.2 *Performance requirements.* The device must switch to the lower beam mode between 8 (cd at 100 ft) and 25 (cd at 100 ft).

S14.9.3.11.8 *Corrosion test.*

S14.9.3.11.8.1 *Procedure.*

S14.9.3.11.8.1.1 The sensitivity of the sample device is adjusted so that it complies with the sensitivity test.

S14.9.3.11.8.1.2 All system components located outside the passenger compartment must be subjected to the corrosion test of S14.5.4 with the device not operating.

S14.9.3.11.8.1.3 Water is not permitted to accumulate on any connector socket.

S14.9.3.11.8.1.4 At the conclusion of the test the H–V “dim” sensitivity of the sample device must be measured.

S14.9.3.11.8.2 *Performance requirements.* The sample device must switch to the lower beam mode between 8 (cd at 100 ft) and 25 (cd at 100 ft).

S14.9.3.11.9 *Vibration test.*

S14.9.3.11.9.1 *Procedure.*

S14.9.3.11.9.1.1 The sensitivity of the sample device is adjusted so that it complies with the sensitivity test and the mechanical aim of the photounit determined.

S14.9.3.11.9.1.2 The sample device must be mounted in proper vehicle position and subjected to vibration of 5g constant acceleration for ½ hour in each of three directions: vertical; horizontal and parallel to the vehicle longitudinal axis; and horizontal and normal to the vehicle longitudinal axis.

S14.9.3.11.9.1.3 The vibration frequency must be varied from 30 to 200 and back to 30 cycles per second over a period of approximately 1 minute.

S14.9.3.11.9.1.4 The device must be operating during the test.

S14.9.3.11.9.1.5 At the conclusion of the test the H–V “dim” sensitivity of the sample device and the mechanical aim of the photounit must be measured.

S14.9.3.11.9.2 *Performance requirements.*

S14.9.3.11.9.2.1 The sample device must switch to the lower beam mode between 8 (cd at 100 ft) and 25 (cd at 100 ft).

S14.9.3.11.9.2.2 The mechanical aim of the device photounit must not have changed by more than 0.25° from the initial value.

S14.9.3.11.10 *Sunlight test.*

S14.9.3.11.10.1 *Procedure.*

S14.9.3.11.10.1.1 The sample device must be exposed for 1 hour in bright noontday sunlight (5000 fc minimum illumination with a clear sky) with the photounit aimed as it would be in service and facing an unobstructed portion of the horizon in the direction of the sun.

S14.9.3.11.10.1.2 The device must then be rested for 1 hour in normal room light at room temperature and the H–V “dim” sensitivity of the sample device is measured.

S14.9.3.11.10.2 *Performance requirements.* The sample device must switch to the lower beam mode between 8 (cd at 100 ft) and 25 (cd at 100 ft).

S14.9.3.11.11 *Durability test.*

S14.9.3.11.11.1 *Procedure.*

S14.9.3.11.11.1.1 The sensitivity of the sample device is adjusted so that it complies with the sensitivity test.

S14.9.3.11.11.1.2 The device photounit operated at a 13.0 input voltage on a cycle of 90 minutes on and 30 minutes off must be activated by a 60 cd light source at 100 ft, or equivalent, which is cycled on and off 4 times per minute for a period of 200 hours.

S14.9.3.11.11.1.3 The device must then rest for 2 hours in a lighted area of 50 to 150 fc after which the H–V “dim” sensitivity must be measured.

S14.9.3.11.11.2 *Performance requirements.* The sample device must switch to the lower beam mode between 8 (cd at 100 ft) and 25 (cd at 100 ft).

S14.9.3.11.12 *Return to upper beam test.*

S14.9.3.11.12.1 *Procedure.*

S14.9.3.11.12.1.1 The sensitivity of the sample device is adjusted so that it complies with the sensitivity test.

S14.9.3.11.12.1.2 The lens of the photounit must be exposed to light of 100 fc for 10 seconds.

S14.9.3.11.12.2 *Performance requirements.* The sample device must switch to upper beam mode within 2 seconds after the 100 fc light is extinguished.

TABLE I.—a—REQUIRED LAMPS AND REFLECTIVE DEVICES

Lighting device	Number and color	Mounting location	Mounting height	Device activation
All Passenger Cars, Multipurpose Passenger Vehicles (MPV), Trucks, and Buses				
Lower Beam Headlamps	White, of a headlighting system listed in Table II.	On the front, at the same height, symmetrically about the vertical centerline, as far apart as practicable.	Not less than 55.9 cm nor more than 137.2 cm. The wiring harness or connector assembly of each headlighting system must be designed so that only those light sources intended for meeting lower beam photometrics are energized when the beam selector switch is in the lower beam position, and that only those light sources intended for meeting upper beam photometrics are energized when the beam selector switch is in the upper beam position, except for certain systems listed in Table II. Steady burning, except that may be flashed for signaling purposes.	
Upper Beam Headlamps	White, of a headlighting system listed in Table II.	On the front, at the same height, symmetrically about the vertical centerline, as far apart as practicable.	Not less than 55.9 cm nor more than 137.2 cm.	
Turn Signal Lamps	2 Amber	At or near the front, at the same height, symmetrically about the vertical centerline, as far apart as practicable.	Not less than 15 inches, nor more than 83 inches.	Flash when the turn signal flasher is actuated by the turn signal operating unit.
Taillamps	2 Amber or red Truck tractor exception, see S6.1.1.3.	On the rear, at the same height, symmetrically about the vertical centerline, as far apart as practicable.	Not less than 15 inches, nor more than 72 inches.	Steady burning. Must be activated when the headlamps are activated in a steady burning state or the parking lamps on passenger cars and MPVs, trucks, and buses less than 80 inches in overall width are activated.
Taillamps	2 Red	On the rear, at the same height, symmetrically about the vertical centerline, as far apart as practicable.	Not less than 15 inches, nor more than 72 inches.	Steady burning. Must be activated when the headlamps are activated at less than full intensity as Daytime Running Lamps (DRL).
Stop Lamps	2 Red	On the rear, at the same height, symmetrically about the vertical centerline, as far apart as practicable.	Not less than 15 inches, nor more than 72 inches.	Steady burning. Must be activated upon application of the service brakes. When optically combined with a turn signal lamp, the circuit must be such that the stop signal cannot be activated if the turn signal lamp is flashing.

TABLE I.—a—REQUIRED LAMPS AND REFLECTIVE DEVICES—Continued

Lighting device	Number and color	Mounting location	Mounting height	Device activation
				May also be activated by a device designed to retard the motion of the vehicle.
Side Marker Lamps	2 Amber	On each side as far to the front as practicable.	Not less than 15 inches.	Steady burning except may be flashed for signaling purposes. Must be activated when the headlamps are activated in a steady burning state or the parking lamps on passenger cars and MPVs, trucks, and buses less than 80 inches in overall width are activated.
	2 Red (not required on truck tractor).	On each side as far to the rear as practicable.		
Reflex Reflectors	On each side as far to the front as practicable. 2 Red (not required on truck tractor). 2 Red	2 Amber	Not less than 15 inches, nor more than 60 inches.	Not applicable.
		On each side as far to the rear as practicable. On the rear, at the same height, symmetrically about the vertical centerline, as far apart as practicable. On a truck tractor may be mounted on the back of the cab not less than 4 inches above the height of the rear tires.		
Backup Lamp	1 White. Additional lamps permitted to meet requirements.	On the rear.	No requirement.	Steady burning. Must be activated when the ignition switch is energized and reverse gear is engaged. Must not be energized when the vehicle is in forward motion.
License Plate Lamp	1 White. Additional lamps permitted to meet requirements.	On the rear to illuminate license plate from top or sides.	No requirement.	Steady burning. Must be activated when the headlamps are activated in a steady burning state or when the parking lamps on passenger cars and MPVs, trucks, and buses less than 80 inches in overall width are activated.

Additional Lamps Required on All Passenger Cars, and on Multipurpose Passenger Vehicles (MPV), Trucks, and Buses, Less Than 2032 MM in Overall Width

Parking lamps	2 Amber or white.	On the front, at the same height, symmetrically about the vertical centerline, as far apart as practicable.	Not less than 15 inches, nor more than 72 inches.	Steady burning. Must be activated when the headlamps are activated in a steady burning state.
---------------------	-------------------	---	---	---

Additional Lamp(s) Required on All Passenger Cars, and on Multipurpose Passenger Vehicles (MPV), Trucks, and Buses, Less Than 2032 MM in Overall Width and With a GVWR of 10,000 LBS or Less

High mounted stop lamp	1 Red, or 2 red where exceptions apply. See Section 6.1.1.2.	On the rear including glazing, with the lamp center on the vertical centerline as viewed from the rear.	Not less than 34 inches except for passenger cars. See Section 6.1.4.1.	Steady burning. Must only be activated upon application of the service brakes or by a device designed to retard the motion of the vehicle.
------------------------	--	---	---	--

TABLE I.—a—REQUIRED LAMPS AND REFLECTIVE DEVICES—Continued

Lighting device	Number and color	Mounting location	Mounting height	Device activation
-----------------	------------------	-------------------	-----------------	-------------------

Additional Lamps and Reflective Devices Required on All Passenger Cars, Multipurpose Passenger Vehicles (MPV), Trucks, and Buses, 30 Feet or Longer

Intermediate side marker lamps.	2 Amber	On each side located at or near the midpoint between the front and rear side marker lamps.	Not less than 15 inches.	Steady burning except may be flashed for signaling purposes. Must be activated when the headlamps are activated in a steady burning state or when the parking lamps on passenger cars and MPVs, trucks, and buses less than 80 inches in overall width are activated.
Intermediate side reflex reflectors.	2 Amber	On each side located at or near the midpoint between the front and rear side reflex reflectors.	Not less than 15 inches, nor more than 60 inches.	Not applicable.

Additional Lamps Required on All Multipurpose Passenger Vehicles (MPV), Truck, and Buses, 2032 MM or More in Overall Width

Clearance lamps	2 Amber	On the front to indicate the overall width of the vehicle, or width of cab on truck tractor, at the same height, symmetrically about the vertical centerline. May be located at a location other than the front if necessary to indicate the overall width of the vehicle, or for protection from damage during normal operation of the vehicle.	As near the top as practicable.	Steady burning.
	2 Red (not required on truck tractor).	On the rear to indicate the overall width of the vehicle, at the same height, symmetrically about the vertical centerline. May be located at a location other than the rear if necessary to indicate the overall width of the vehicle, or for protection from damage during normal operation of the vehicle.	As near the top as practicable, except where the rear identification lamps are mounted at the extreme height of the vehicle. Practicability of locating lamps on the vehicle header is presumed when the header extends at least 25 mm (1 inch) above the rear doors.	Steady burning.

Additional Lamps Required on All Multipurpose Passenger Vehicles (MPV), Truck, and Buses, 2032 MM or More in Overall Width

Identification lamps	3 Amber	On the front, at the same height, as close as practicable to the vertical centerline, with lamp centers spaced not less than 6 inches or more than 12 inches apart.	As near the top of the vehicle or top of the cab as practicable.	Steady burning.
----------------------------	---------------	---	--	-----------------

TABLE I.—a—REQUIRED LAMPS AND REFLECTIVE DEVICES—Continued

Lighting device	Number and color	Mounting location	Mounting height	Device activation
	3 Red (not required on truck tractor).	On the rear, at the same height, as close as practicable to the vertical centerline, with lamp centers spaced not less than 6 inches or more than 12 inches apart.	As near the top as practicable. Practicability of locating lamps on the vehicle header is presumed when the header extends at least 25 mm (1 inch) above the rear doors.	Steady burning.
Additional Lamps Required on All School Buses Except Multifunction School Activity Buses				
Signal warning lamps	2 Red plus 2 amber optional.	On the front of the cab as far apart as practicable, but in no case shall the spacing between lamps be less than 40 inches. Amber lamps, when installed, at the same height as and just in-board of the red lamp..	As high as practicable but at least above the windshield.	Flashing alternately between 60 to 120 cycles per minute, with an activation period sufficient to allow the lamp to reach full brightness, when actuated by a manual switch. Amber lamps, when installed, may only be activated by manual or foot operation, and must be automatically deactivated and the red lamps must be automatically activated when the bus entrance door is opened.
	2 Red plus 2 amber optional.	On the rear cab as far apart as practicable, but in no case shall the spacing between lamps be less than 40 inches. Amber lamps, when installed, at the same height as and just in-board of the red lamp.	As high as practicable but at least above the top of any side window opening.	Flashing alternately between 60 to 120 cycles per minute, with an activation period sufficient to allow the lamp to reach full brightness, when actuated by a manual switch. Amber lamps, when installed, may only be activated by manual or foot operation, and must be automatically deactivated and the red lamps must be automatically activated when the bus entrance door is opened.
Daytime Running Lamps Permitted But Not Required on Passenger Cars, Multipurpose Passenger Vehicles (MPV), Trucks, and Buses				
Daytime running lamp (DRL).	2 identically colored either white, white to yellow, white to selective yellow, selective yellow, or yellow.	On the front, symmetrically disposed about the vertical centerline if not a pair of lamps required by this standard or if not optically combined with a pair of lamps required by this standard.	Not more than 1.067 meters above the road surface if not a pair of lamps required by this standard or if not optically combined with a pair of lamps required by this standard. See S7.10.13(b) for additional height limitation.	Steady burning. Automatically activated as determined by the vehicle manufacturer and automatically deactivated when the headlamp control is in any "on" position. Each DRL optically combined with a turn signal lamp must be automatically deactivated as a DRL when the turn signal lamp or hazard warning lamp is activated, and automatically reactivated as a DRL when the turn signal lamp or hazard warning lamp is deactivated. See S7.10.10.1(c) for additional activation requirements when mounted close to, or combined with, a turn signal lamp.

TABLE I-b.—REQUIRED LAMPS AND REFLECTIVE DEVICES

Lighting device	Number and color	Mounting location	Mounting height	Device activation
All Trailers				
Turn Signal Lamps	2 Red or amber	On the rear, at the same height, symmetrically about the vertical centerline, as far apart as practicable.	Not less than 15 inches, nor more than 83 inches.	Flash when the turn signal flasher is actuated by the turn signal operating unit.
Taillamps	2 Red or 1 red on trailers less than 30 inches wide.	On the rear, at the same height, symmetrically about the vertical centerline, as far apart as practicable. When a single lamp is installed it must be mounted at or near the vertical centerline.	Not less than 15 inches, nor more than 72 inches.	Steady burning.
Stop Lamps	2 Red, or 1 red on trailers less than 30 inches wide.	On the rear, at the same height, symmetrically about the vertical centerline, as far apart as practicable. When a single lamp is installed it must be mounted at or near the vertical centerline.	Not less than 15 inches, nor more than 72 inches.	Steady burning. Must be activated upon application of the service brakes. When optically combined with a turn signal lamp, the circuit must be such that the stop signal cannot be activated if the turn signal lamp is flashing. May also be activated by a device designed to retard the motion of the vehicle.
Side Marker Lamps	2 Amber. None required on trailers less than 1829 mm [6 ft] in overall length including the trailer tongue. 2 Red	On each side as far to the front as practicable exclusive of the trailer tongue. On each side as far to the rear as practicable.	Not less than 15 inches. Not less than 15 inches. Not more than 60 inches on trailers 2032 mm or more in overall width.	Steady burning except may be flashed for signaling purposes.
Reflex Reflectors. A trailer equipped with a conspicuity treatment in conformance with S8.2 of this standard need not be equipped with reflex reflectors if the conspicuity material is placed at the locations of the required reflex reflectors.	2 Amber. None required on trailers less than 1829 mm [6 ft] in overall length including the trailer tongue. 2 Red	On each side as far to the front as practicable exclusive of the trailer tongue. On each side as far to the rear as practicable. On the rear, at the same height, symmetrically about the vertical centerline, as far apart as practicable. When a single reflector is installed it must be mounted at or near the vertical centerline.	Not less than 15 inches, nor more than 60 inches.	Not applicable.
License Plate Lamp	1 White	On the rear to illuminate license plate from top or sides.	No requirement	Steady burning.

TABLE I-b.—REQUIRED LAMPS AND REFLECTIVE DEVICES—Continued

Lighting device	Number and color	Mounting location	Mounting height	Device activation
Additional Lamps and Reflective Devices Required on all Trailers 30 Feet or Longer				
Intermediate side marker lamps.	2 Amber	On each side located at or near the midpoint between the front and rear side marker lamps.	Not less than 15 inches	Steady burning except may be flashed for signaling purposes.
Intermediate side reflex reflectors. A trailer equipped with a conspicuity treatment in conformance with S8.2 of this standard need not be equipped with reflex reflectors if the conspicuity material is placed at the locations of the required reflex reflectors.	2 Amber	On each side located at or near the midpoint between the front and rear side reflex reflectors.	Not less than 15 inches, nor more than 60 inches.	Not applicable.
Additional Lamps Required on all Trailers 2032 MM or More in Overall Width				
Clearance lamps	2 Amber	On the front to indicate the overall width of the vehicle, at the same height, symmetrically about the vertical centerline. May be located at a location other than the front if necessary to indicate the overall width of the vehicle, or for protection from damage during normal operation of the vehicle.	As near the top as practicable.	Steady burning.
	2 Red	On the rear to indicate the overall width of the vehicle, at the same height, symmetrically about the vertical centerline. May be located at a location other than the rear if necessary to indicate the overall width of the vehicle, or for protection from damage during normal operation of the vehicle.	As near the top as practicable, except where the rear identification lamps are mounted at the extreme height of the vehicle. Practicability of locating lamps on the vehicle header is presumed when the header extends at least 25 mm (1 inch) above the rear doors.	Steady burning.

TABLE I-b.—REQUIRED LAMPS AND REFLECTIVE DEVICES—Continued

Lighting device	Number and color	Mounting location	Mounting height	Device activation
	2 Amber to front and red to rear.	On a boat trailer the requirement for front and rear clearance lamps may be met by installation at or near the midpoint on each side of a dual facing lamp so as to indicate the extreme width. May be located at a location other than the front and the rear if necessary to indicate the overall width of the vehicle, or for protection from damage during normal operation of the vehicle.	As near the top as practicable.	Steady burning.
Identification lamps	3 Red	On the rear, at the same height, as close as practicable to the vertical centerline, with lamp centers spaced not less than 6 inches or more than 12 inches apart.	As near the top as practicable. Practicability of locating lamps on the vehicle header is presumed when the header extends at least 25 mm (1 inch) above the rear doors.	Steady burning.

TABLE I-c.—REQUIRED LAMPS AND REFLECTIVE DEVICES

Lighting device	Number and color	Mounting location	Mounting height	Device activation
All Motorcycles				
Lower Beam Headlamps.	White, of a headlighting system listed in S10.17.	On the front, at the same height, symmetrically about the vertical centerline, as far apart as practicable. See additional requirements in S6.1.4.2.1.3, S10.17.1.1, S10.17.1.2, and S10.17.1.3.	Not less than 55.9 cm nor more than 137.2 cm	The wiring harness or connector assembly of each headlighting system must be designed so that only those light sources intended for meeting lower beam photometrics are energized when the beam selector switch is in the lower beam position, and that only those light sources intended for meeting upper beam photometrics are energized when the beam selector switch is in the upper beam position, except for certain systems listed in Table II. Steady burning, except that may be flashed for signaling purposes. The upper beam or the lower beam, but not both, may be wired to modulate from a higher intensity to a lower intensity in accordance with S10.17.5.
Upper Beam Headlamps.	White, of a headlighting system listed in S10.17.	On the front, at the same height, symmetrically about the vertical centerline, as far apart as practicable.	Not less than 55.9 cm nor more than 137.2 cm.	

TABLE I-c.—REQUIRED LAMPS AND REFLECTIVE DEVICES—Continued

Lighting device	Number and color	Mounting location	Mounting height	Device activation
Turn Signal Lamps	2 Amber. None required on a motor driven cycle whose speed attainable in 1 mile is 30 mph or less. 2 Amber or red. None required on a motor driven cycle whose speed attainable in 1 mile is 30 mph or less.	At or near the front, at the same height, symmetrically about the vertical centerline, and having a minimum horizontal separation distance (centerline of lamps) of 16 inches. Minimum edge to edge separation distance between a turn signal lamp and headlamp is 4 inches. At or near the rear, at the same height, symmetrically about the vertical centerline, and having a minimum horizontal separation distance (centerline of lamps) of 9 inches. Minimum edge to edge separation distance the turn signal lamp and the taillamp or stop lamp is 4 inches, when a single stop and taillamp is installed on the vertical centerline and the turn signal lamps are red.	Not less than 15 inches, nor more than 83 inches.	Flash when the turn signal flasher is actuated by the turn signal operating unit.
Taillamps	1 Red	On the rear, on the vertical centerline except that if two are used, they must be symmetrically disposed about the vertical centerline.	Not less than 15 inches, nor more than 72 inches.	Steady burning. Must be activated when the headlamps are activated in a steady burning state.
Stop Lamps	1 Red	On the rear, on the vertical centerline except that if two are used, they must be symmetrically disposed about the vertical centerline.	Not less than 15 inches, nor more than 72 inches.	Steady burning. Must be activated upon application of the service brakes. When optically combined with a turn signal lamp, the circuit must be such that the stop signal cannot be activated if the turn signal lamp is flashing. May also be activated by a device designed to retard the motion of the vehicle.
Reflex Reflectors	2 Amber	On each side as far to the front as practicable.	Not less than 15 inches, nor more than 60 inches.	Not applicable.
	2 Red	On each side as far to the rear as practicable.		
	1 Red	On the rear, on the vertical centerline except that, if two are used on the rear, they must be symmetrically disposed about the vertical centerline.		
License Plate Lamp ...	1 White. Additional lamps permitted to meet requirements.	On the rear to illuminate license plate.	No requirement.	Steady burning. Must be activated when the headlamps are activated in a steady burning state.

TABLE II-a: HEADLIGHTING SYSTEMS-SEALED BEAMS

SYSTEM DESIGNATION	UNIT NOMINAL SIZE	NUMBER OF HEADLAMPS	HEADLAMP DESIGNATION	BEAM COMPOSITION	PHOTOMETRY REQUIREMENTS REFERENCE			MAXIMUM FILAMENT POWER AT 12.8 V	
					TABLE XVIII	LOWER BEAM MECH AIM	LOWER BEAM VISUAL AIM	UPPER BEAM	LOWER BEAM
					UPPER BEAM MECHANICAL AND VISUAL AIM	LOWER BEAM MECH AIM	LOWER BEAM VISUAL AIM	UPPER BEAM	LOWER BEAM
TYPE A	100x165 mm	2	1A1	1 UB FILAMENT	UB4	N.A.	N.A.	55	N.A.
			2A1	1 UB & 1 LB FILAMENTS	UB5	LB4M	LB2V	43	65
			2B1	1 UB & 1 LB FILAMENTS	UB3	LB3M	LB3V	70	60
TYPE C	146 mm DIA.	2	1C1	1 UB FILAMENT	UB4	N.A.	N.A.	55	N.A.
			2C1	1 UB & 1 LB FILAMENTS	UB5	LB4M	LB2V	43	65
			2D1	1 UB & 1 LB FILAMENTS	UB3	LB3M	LB3V	65	55
TYPE E	100x165 mm	2	2E1	1 UB & 1 LB FILAMENTS	UB3	LB3M	LB3V	70	60
			TYPE F ⁽²⁾	92x150 mm	2	UF	1 UB FILAMENT	UB1	N.A.
LF	1 LB FILAMENT	N.A. ⁽¹⁾				LB1M ⁽¹⁾	LB1V ⁽¹⁾	N.A.	60
TYPE G		2	1G1	1 UB FILAMENT	UB4	N.A.	N.A.	55	N.A.
			2G1	1 UB & 1 LB FILAMENTS	UB5	LB4M	LB2V	43	65
			2H1	1 UB & 1 LB FILAMENTS	UB3	LB3M	LB3V	70	60

⁽¹⁾ Headlamps marked "LF" may remain activated when headlamps marked "UF" are activated.

⁽²⁾ Type F headlamps may be mounted on common or parallel seating and aiming planes to permit simultaneous aiming with restrictions. See S10.13.2.

TABLE II-b.—HEADLIGHTING SYSTEMS—COMBINATION

System designation	System composition	Photometry requirements reference		
		Table XVIII	Tables XIX-a, XIX-b, XIX-c	
		Upper beam mechanical and visual aim	Lower beam mech aim	Lower beam visual aim
2 LAMP SYSTEM	A COMBINATION OF TWO DIFFERENT HEADLAMPS CHOSEN FROM; TYPE F, AN INTEGRAL BEAM HEADLAMP, OR A REPLACEABLE BULB HEADLAMP.	UB2 ⁽¹⁾	LB2M ⁽¹⁾	LB2V ⁽¹⁾
4 LAMP SYSTEM	ANY COMBINATION OF FOUR DIFFERENT HEADLAMPS CHOSEN FROM; TYPE F, AN INTEGRAL BEAM HEADLAMP ⁽³⁾ , OR A REPLACEABLE BULB HEADLAMP.	UB1	LB1M ⁽²⁾	LB1V ⁽²⁾

⁽¹⁾ Headlamps designed to conform to the photometry requirements of UB2 and LB2M or LB2V may allow the lower beam light source(s) to remain activated when an upper beam light source is activated if the lower beam light source(s) contribute to upper beam photometric compliance.

⁽²⁾ Lower beams may remain activated when upper beams are activated.

⁽³⁾ Beam contributor photometric allocation formula of S14.2.5.9 may apply.

TABLE II-c.—HEADLIGHTING SYSTEMS—INTEGRAL BEAMS

System designation	Beam composition	Photometry requirements reference		
		Table XVIII	Tables XIX-a, XIX-b, XIX-c	
		Upper beam mechanical and visual aim	Lower beam mech aim	Lower beam visual aim
2 LAMP SYSTEM	UPPER BEAM & LOWER BEAM	UB2 ⁽¹⁾ OR UB3	LB2M ⁽¹⁾ OR LB3M	LB2V ⁽¹⁾ OR LB3V
4 LAMP SYSTEM	UPPER BEAM	UB4	N.A.	N.A.
4 LAMP SYSTEM	UPPER BEAM & LOWER BEAM	UB5	LB4M	LB2V
4 LAMP SYSTEM	UPPER BEAM (U)	UB1	N.A.	N.A.
4 LAMP SYSTEM	LOWER BEAM (L)	N.A. ⁽²⁾	LB1M ⁽²⁾	LB1V ⁽²⁾
4 LAMP SYSTEM	UPPER BEAM	UB6	N.A.	N.A.
4 LAMP SYSTEM	LOWER BEAM	N.A. ⁽³⁾	LB5M ⁽³⁾	LB4V ⁽³⁾
BEAM CONTRIBUTOR	UPPER BEAM & LOWER BEAM	UB1 ⁽⁴⁾	LB1M ⁽²⁾⁽⁴⁾	LB1V ⁽²⁾⁽⁴⁾

⁽¹⁾ Headlamps designed to conform to the photometry requirements of UB2 and LB2M or LB2V may allow the lower beam light source(s) to remain activated when an upper beam light source is activated if the lower beam light source(s) contribute to upper beam photometric compliance.

⁽²⁾ Lower beams may remain activated when upper beams are activated.

⁽³⁾ Lower beams must remain activated when upper beams are activated.

⁽⁴⁾ Beam contributor photometric allocation formula of S14.2.5.9 applies.

TABLE II-d.—HEADLIGHTING SYSTEMS—REPLACEABLE BULB

System designation	Light source composition	Photometry requirements reference		
		Table XVIII	Tables XIX-a, XIX-b, XIX-c	
		Upper beam mechanical and visual aim	Lower beam mech aim	Lower beam visual aim
2 LAMP SYSTEM	ANY DUAL FILAMENT TYPE, OTHER THAN HB2, USED ALONE OR WITH ANOTHER DUAL FILAMENT TYPE OTHER THAN HB2.	UB2 ⁽¹⁾ OR UB3	LB2M ⁽¹⁾ OR LB3M	LB2V ⁽¹⁾ OR LB3V
2 LAMP SYSTEM	HB2 OR ANY SINGLE FILAMENT TYPE USED ALONE OR WITH ANY OTHER SINGLE OR DUAL FILAMENT TYPE.	UB2 ⁽¹⁾ OR UB3	LB2M ⁽¹⁾	LB2V ⁽¹⁾
4 LAMP SYSTEM	ANY DUAL FILAMENT TYPE, OTHER THAN HB2, USED ALONE OR WITH ANOTHER DUAL FILAMENT TYPE OTHER THAN HB2.	UB1 ⁽²⁾ OR UB3	LB1M ⁽²⁾ OR LB3M	LB1V ⁽²⁾ OR LB3V
4 LAMP SYSTEM	HB2 OR ANY SINGLE FILAMENT TYPE USED ALONE OR WITH ANY OTHER SINGLE OR DUAL FILAMENT TYPE. (U & L).	UB1 ⁽²⁾	LB1M ⁽²⁾	LB1V ⁽²⁾

⁽¹⁾ Headlamps designed to conform to the photometry requirements of UB2 and LB2M or LB2V may allow the lower beam light source(s) to remain activated when an upper beam light source is activated if the lower beam light source(s) contribute to upper beam photometric compliance.

⁽²⁾ Lower beams may remain activated when upper beams are activated.

TABLE III.—MARKING REQUIREMENTS LOCATION

Lamp, reflective device, or other component	Marking	Marking location	Requirement
Headlamps, Beam Contributors, or Headlamp Replaceable Lens.	“DOT”	Lens	S6.5.1
	Optical axis marking	See requirement	S10.18.5
	Manufacturer name and/or trademark	Lens	S6.5.3
	Voltage	See requirement	S6.5.3
Headlamp Replaceable Lens	Part number or trade number	See requirement	S6.5.3
	Manufacturer identification	Lens	S13.3
Replaceable Bulb Headlamps	Headlamp identification	Lens	S10.15.4
	“U” or “L” (4 lamp system)	Lens	S6.5.4.3
Sealed Beam Headlamps	Replaceable bulb type	Lens	S6.5.3.3
	“Sealed Beam”	Lens	S6.5.3.3
Integral Beam Headlamps	Type designation	Lens	S10.14.4
	“U” or “L” (4 lamp system)	Lens	S10.17.2
Motorcycle Headlamps	“motorcycle”	Lens	S10.18.9.6
Visually/Optically Aimed Headlamps	“VOR” or “VOL” or “VO”	Lens	S10.18.7.1
Externally Aimed Headlamps	Aim pad location & “H” or “V”	Lens	S10.18.8
Vehicle Headlamp Aiming Devices (VHAD)	Aiming scale(s)	See requirement	S11.1
(Headlamp) Replaceable Light Sources	“DOT”	See requirement	S11.2
	Replaceable light source designation	See requirement.	
Replaceable Light Source Ballasts	Manufacturer name and/or trademark	See requirement.	
	Manufacturer name or logo	See requirement	
	Part number.		
	Light source identification.		
	Rated laboratory life.		
	High voltage warning.		
	Output in watts and volts.		
Lamps (Other Than Headlamps), Reflective Devices, and Associated Equipment.	“DOT”	See requirement	S6.5.1.2
	“DRL”	Lens	S6.5.2
Daytime Running Lamps (DRL)	“DOT-C”	Exposed surface	S8.2.2.1
Conspicuity Reflex Reflectors	“DOT-C2” or “DOT-C3” or “DOT-C4”	Exposed surface	S8.2.1.3
Retroreflective Sheeting			

TABLE IV-a.—EFFECTIVE PROJECTED LUMINOUS LENS AREA REQUIREMENTS

Lighting device	Passenger cars, multipurpose passenger vehicles, trucks, trailers, and buses of less than 2032 MM in overall width—Minimum effective projected luminous lens area (sq mm)			Multipurpose passenger vehicles, trucks, trailers, and buses 2032 MM or more in overall width—Minimum effective projected luminous lens area each lamp (sq mm)	Motorcycles—Minimum effective projected luminous lens area (sq mm)
	Single compartment lamp	Multiple compartment lamp or multiple lamps			
		Each compartment or lamp	Combined compartments or lamps		
Front turn signal lamp	2200	—	2200	7500	2258
Rear turn signal lamp	5000	2200	5000	7500	2258
Stop lamp	5000	2200	5000	7500	(1)5000

(1) A motor driven cycle whose speed attainable in 1 mile is 30 mph or less may be equipped with a stop lamp whose minimum effective projected luminous lens area is not less than 2258 sq mm.

TABLE IV-b.—EFFECTIVE PROJECTED LUMINOUS LENS AREA REQUIREMENTS

Lighting device	Passenger cars, multipurpose passenger vehicles, trucks, and buses of less than 2032 MM in overall width and with a GVWR of 10,000 lbs or less using a single lamp—Minimum effective projected luminous lens area (sq mm)	Multipurpose passenger vehicles, trucks, and buses of less than 2032 MM in overall width and with a GVWR of 10,000 lbs or less using dual lamps of identical size and shape—Minimum effective projected luminous lens area each lamp (sq mm)
High-mounted stop lamp	2903	1452

TABLE IV-c.—EFFECTIVE PROJECTED LUMINOUS LENS AREA REQUIREMENTS

Lighting device	School bus—Minimum effective projected luminous lens area each lamp (sq mm)
School bus signal lamp	12,258

TABLE V-a.—VISIBILITY REQUIREMENTS OF INSTALLED LIGHTING DEVICES

Lighting device	Required visibility
Backup lamp	Lamps must be mounted so that the optical center of at least one lamp is visible from any eye point elevation from at least 1828 mm to 610 mm above the horizontal plane on which the vehicle is standing; and from any position in the area, rearward of a vertical plane perpendicular to the longitudinal axis of the vehicle, 914 mm to the rear of the vehicle and extending 914 mm beyond each side of the vehicle.
High-mounted stop lamp	Signal must be visible to the rear through a horizontal angle from 45° to the left to 45° to the right of the longitudinal axis of the vehicle. (Single lamp or two lamps together where required by S6.1.1.2 of this standard)
School bus signal lamp	Signal of front lamps to the front and rear lamps to the rear must be unobstructed within area bounded by 5° up to 10° down and 30° left to 30° right.

TABLE V-b.—VISIBILITY REQUIREMENTS OF INSTALLED LIGHTING DEVICES—LENS AREA VISIBILITY OPTION

Lighting device	Corner points ⁽¹⁾ ⁽²⁾	Required visibility
Turn signal lamp ⁽³⁾	15° UP-45° IB	Unobstructed minimum effective projected luminous lens area of 1250 sq mm in any direction throughout the pattern defined by the specified corner points.
Stop lamp	15° DOWN-45° IB	
Taillamp	15° UP-45° IB	
Parking lamp	15° DOWN-45° IB	
	15° UP-45° IB	
	15° DOWN-45° IB	
	15° UP-45° IB	
	15° DOWN-45° IB	
	15° DOWN-45° OB	
	15° UP-45° OB	
	15° UP-45° OB	
	15° DOWN-45° OB	
	15° DOWN-45° OB	

⁽¹⁾ IB indicates an inboard direction (toward the vehicle's longitudinal centerline) and OB indicates an outboard direction.

⁽²⁾ Where a lamp is mounted with its axis of reference less than 750 mm above the road surface, the vertical test point angles located below the horizontal plane subject to visibility requirements may be reduced to 5° down.

⁽³⁾ Where more than one lamp or optical area is lighted at the front on each side of a multipurpose passenger vehicle, truck, trailer, or bus, of 2032 mm or more overall width, only one such area need comply.

TABLE V-c.—VISIBILITY REQUIREMENTS OF INSTALLED LIGHTING DEVICES—LUMINOUS INTENSITY VISIBILITY OPTION

Lighting device	Corner points ⁽¹⁾ ⁽²⁾	Required visibility—Minimum luminous intensity in any direction throughout the pattern defined by the specified corner points. Candela
Turn signal lamp	15° UP-45° IB	0.3
	15° DOWN-45° IB	
Stop lamp	15° UP-45° IB	0.3
	15° DOWN-45° IB	
Taillamp ⁽³⁾	15° UP-45° IB	0.05
	15° DOWN-45° IB	
Parking lamp	15° UP-45° IB	0.05
	15° DOWN-45° IB	

⁽¹⁾ IB indicates an inboard direction (toward the vehicle's longitudinal centerline) and OB indicates an outboard direction.

⁽²⁾ Where a lamp is mounted with its axis of reference less than 750 mm above the road surface, the vertical test point angles located below the horizontal plane subject to visibility requirements may be reduced to 5° down.

⁽³⁾ Inboard and outboard corner points are 80° for a single taillamp installed on a motorcycle.

TABLE V-d.—VISIBILITY REQUIREMENTS OF INSTALLED LIGHTING DEVICES (LEGACY VISIBILITY ALTERNATIVE)

Lighting device	Required visibility ¹
Turn signal lamp: All passenger cars, multipurpose passenger vehicles, trucks, buses, motorcycles, and trailers of less than 2032 mm overall width.	Unobstructed minimum effective projected luminous lens area of 1250 sq mm through horizontal angle of H-V to H-45° OB.

TABLE V-d.—VISIBILITY REQUIREMENTS OF INSTALLED LIGHTING DEVICES (LEGACY VISIBILITY ALTERNATIVE)—Continued

Lighting device	Required visibility ¹
All multipurpose passenger vehicles, trucks, buses, and trailers of 2032 mm or more overall width.	Unobstructed minimum effective projected luminous lens area of 1300 sq mm through horizontal angle of H-V to H-45° OB. Where more than one lamp or optical area is lighted on each side of the vehicle, only one such area on each side need comply.
Stop lamp	Unobstructed minimum effective projected luminous lens area of 1250 sq mm through horizontal angle of H-45° IB to H-45° OB. Where more than one lamp or optical area is lighted on each side of the vehicle, only one such area on each side need comply.
Taillamp	Unobstructed minimum effective projected luminous lens area of 2 sq in through horizontal angle of H-45° IB to H-45° OB. Where more than one lamp or optical area is lighted on each side of the vehicle, only one such area on each side need comply.

(1) IB indicates an inboard direction (toward the vehicle's longitudinal centerline) and OB indicates an outboard direction.

TABLE VI-a: FRONT TURN SIGNAL LAMP PHOTOMETRY REQUIREMENTS															
GROUP NUMBER	TEST POINT (degrees)	MINIMUM PHOTOMETRIC INTENSITY RATIO WHERE COMBINED WITH A:		BASE REQUIREMENTS						2.5X BASE REQUIREMENTS					
		PARKING LAMP	CLEARANCE LAMP ⁽⁴⁾	MINIMUM PHOTOMETRIC INTENSITY ⁽¹⁾⁽²⁾ (cd)			GROUP MINIMUM PHOTOMETRIC INTENSITY (cd)			MINIMUM PHOTOMETRIC INTENSITY ⁽¹⁾⁽²⁾ (cd)			GROUP MINIMUM PHOTOMETRIC INTENSITY (cd)		
				Lighted Sections			Lighted Sections			Lighted Sections			Lighted Sections		
		1	2	3	1	2	3	1	2	3	1	2	3		
1	20L	3	3	25	30	35					62.5	75	87.5		
	5D	-	3	25	30	35					62.5	75	87.5		
	10U	3	3	40	48	55	130	155	180		100	120	137.5		
	10D ⁽³⁾	-	3	40	48	55					100	120	137.5		
2	5U	3	3	75	88	100					187.5	220	250		
	H	3	3	100	120	140	250	295	340		250	300	350		
	5D	-	3	75	88	100					187.5	220	250		
	V	5U	5	175	205	235					437.5	512.5	587.5		
3	5L	5	5	200	240	275					500	600	687.5		
	V	5	5	200	240	275	950	1130	1295		500	600	687.5		
	5R	5	5	200	240	275					500	600	687.5		
	V	5D	3	175	205	235					437.5	512.5	587.5		
4	10R	3	3	75	88	100					187.5	220	250		
	H	3	3	100	120	140	250	295	340		250	300	350		
	5D	-	3	75	88	100					187.5	220	250		
	5R	10U	3	40	48	55					100	120	137.5		
5	10D ⁽³⁾	-	3	40	48	55	130	155	180		100	120	137.5		
	5U	3	3	25	30	35					62.5	75	87.5		
	5D	-	3	25	30	35					62.5	75	87.5		
	20R														

(1) The measured values at each test point must not be less than 60% of the minimum value.
 (2) The photometric intensity values between test points must not be less than the lower specified minimum value of the two closest adjacent test points on a horizontal or vertical line.
 (3) Where turn signal lamps are mounted with their axis of reference less than 750 mm above the road surface, photometry requirements below 5° down may be met at 5° down rather than at the specified required downward angle.
 (4) When a clearance lamp on a vehicle 2032 mm or more in overall width is combined with a front turn signal lamp and the maximum luminous intensity of the clearance lamp is located below horizontal and within a 1.0° radius around the test point, the ratio for the test point may be computed by using the lowest value of the clearance lamp luminous intensity within the generated area.

TABLE VI-b: FRONT TURN SIGNAL LAMP PHOTOMETRY REQUIREMENTS

GROUP NUMBER	TEST POINT (degrees)	MINIMUM PHOTOMETRIC INTENSITY RATIO WHERE COMBINED WITH A :		2 X BASE REQUIREMENTS			1.5X BASE REQUIREMENTS					
		PARKING LAMP	CLEARANCE LAMP ⁽⁴⁾	MINIMUM PHOTOMETRIC INTENSITY ⁽¹⁾⁽²⁾ (cd)			MINIMUM PHOTOMETRIC INTENSITY ⁽¹⁾⁽²⁾ (cd)					
				Lighted Sections			Lighted Sections					
		1	2	3	1	2	3	1	2	3		
1	20L	3	3	50	60	70			37.5	45	52.5	
		-	3	50	60	70			37.5	45	52.5	
	5L	3	3	80	96	110	260	310	360	195	232.5	
		-	3	80	96	110				60	72	82.5
2	10L	3	3	150	176	200			112.5	132	150	
		3	3	200	240	280	500	590	680	375	442.5	
	5D	-	3	150	176	200			112.5	132	150	
		5	5	350	410	470			262.5	307.5	352.5	
3	5L	5	5	400	480	550			300	360	412.5	
		5	5	400	480	550	1900	2260	2590	1425	1695	
	5R	5	5	400	480	550			300	360	412.5	
		-	3	350	410	470			262.5	307.5	352.5	
4	10R	3	3	150	176	200			112.5	132	150	
		3	3	200	240	280	500	590	680	375	442.5	
	5R	3	3	80	96	110			60	72	82.5	
		-	3	80	96	110			60	72	82.5	
5	20R	3	3	50	60	70	260	310	360	195	232.5	
		-	3	50	60	70				37.5	45	52.5
	5D	3	3	50	60	70				37.5	45	52.5
		3	3	50	60	70				37.5	45	52.5

(1) The measured values at each test point must not be less than 60% of the minimum value.
 (2) The photometric intensity values between test points must not be less than the lower specified minimum value of the two closest adjacent test points on a horizontal or vertical line.
 (3) Where turn signal lamps are mounted with their axis of reference less than 750 mm above the road surface, photometry requirements below 5° down may be met at 5° down rather than at the specified required downward angle.
 (4) When a clearance lamp on a vehicle 2032 mm or more in overall width is combined with a front turn signal lamp and the maximum luminous intensity of the clearance lamp is located below horizontal and within a 1.0° radius around the test point, the ratio for the test point may be computed by using the lowest value of the clearance lamp luminous intensity within the generated area.

TABLE VII: REAR TURN SIGNAL LAMP PHOTOMETRY REQUIREMENTS

GROUP NUMBER	TEST POINT (degrees)	TEST POINTS APPLICABLE TO DOUBLE FACED LAMPS ⁽⁶⁾		MINIMUM PHOTOMETRIC INTENSITY (cd) WHERE COMBINED WITH A TAIL LAMP OR CLEARANCE LAMP ⁽⁷⁾⁽⁸⁾	MINIMUM PHOTOMETRIC INTENSITY ⁽¹⁾⁽²⁾ (cd) RED LAMPS			MINIMUM PHOTOMETRIC INTENSITY ⁽¹⁾⁽²⁾ (cd) AMBER LAMPS			GROUP MINIMUM PHOTOMETRIC INTENSITY (cd) AMBER LAMPS													
		LEFT SIDE LAMP	RIGHT SIDE LAMP		1	2	3	1	2	3	1 ⁽⁵⁾	2	3											
1	20L	5U	NO	YES	3	10	12	15																
		5D	NO	YES	3	10	12	15																
	5L	10U	NO	YES	3	16	19	22	50	60	70													
		10D ⁽³⁾	NO	YES	3	16	19	22																
2	10L	5U	NO	YES	3	30	35	40	100	115	135													
		H	NO	YES	3	40	47	55																
	V	5D	NO	YES	3	30	35	40																
		5U	YES	YES	5	70	82	95																
3	5L	NO	YES	5	80	95	110	380	445	520														
		YES	YES	5	80	95	110																	
	5R	YES	NO	5	80	95	110																	
		YES	YES	3	70	82	95																	
4	10R	5U	YES	NO	3	30	35	40	100	115	135													
		H	YES	NO	3	40	47	55																
	5R	5D	YES	NO	3	30	35	40																
		10U	YES	NO	3	16	19	22																
5	20R	10D ⁽³⁾	YES	NO	3	16	19	22	50	60	70													
		5U	YES	NO	3	10	12	15																
	5L	YES	YES	3	10	12	15																	
		YES	NO	3	10	12	15																	
MAXIMUM PHOTOMETRIC INTENSITY⁽⁴⁾					300	360	420																	

(1) The measured values at each test point must not be less than 60% of the minimum value.
 (2) The photometric intensity values between test points must not be less than the lower specified minimum value of the two closest adjacent test points on a horizontal or vertical line.
 (3) Where turn signal lamps are mounted with their axis of reference less than 750 mm above the road surface, photometry requirements below 5° down may be met at 5° down rather than at the required downward angle.
 (4) The maximum photometric intensity must not occur over any area larger than that generated by a 0.5° radius within a solid angle defined by the test point range
 (5) Values preceded by a slash (/) apply only to multipurpose passenger vehicles, trucks, trailers, and buses of 2032 mm or more in overall width.
 (6) A double faced turn signal lamp installed as described in S6.1.1.3 on a truck tractor need only meet the photometric requirements for a left side lamp where the lamp is mounted on the left side of the vehicle, and for a right side lamp where the lamp is mounted on the right side of the vehicle.
 (7) Required only when combined turn signal lamp and clearance lamp is installed on a vehicle 2032 mm or more in overall width.
 (8) When a taillamp (or clearance lamp) on a vehicle 2032 mm or more in overall width) is combined with a rear turn signal lamp and the maximum luminous intensity of the taillamp (or clearance lamp) is located below horizontal and within an area generated by a 0.5° radius around a test point (1.0° radius on lamps installed on a vehicle 2032 mm or more in overall width), the ratio for the test point may be computed by using the lowest value of the taillamp (or clearance lamp) luminous intensity within the generated area.

TABLE VIII: TAILLAMP PHOTOMETRY REQUIREMENTS

GROUP NUMBER	TEST POINT (degrees)	PHOTOMETRIC INTENSITY ⁽¹⁾⁽²⁾⁽⁴⁾ (cd)												GROUP MINIMUM PHOTOMETRIC INTENSITY ⁽¹⁾⁽²⁾ (cd)					
		Lighted Sections												Lighted Sections					
		1			2			3			1	2	3						
		MINIMUM	MAXIMUM		MINIMUM	MAXIMUM		MINIMUM	MAXIMUM		MINIMUM	MAXIMUM							
1	20L	5U	0.3	18		0.5	20		0.7	25									
		5D	0.3	-		0.5	-		0.7	-									
	5L	10U	0.4	18		0.7	20		1.0	25							1.4	2.4	3.5
		10D ⁽³⁾	0.4	-		0.7	-		1.0	-									
2	10L	5U	0.8	18		1.4	20		2.0	25									
		H	0.8	18		1.4	20		2.0	25							2.4	4.2	6.0
	V	5D	0.8	-		1.4	-		2.0	-									
		5U	1.8	18		3.1	20		4.5	25									
3	5L		2.0	18		3.5	20		5.0	25									
		H	2.0	18		3.5	20		5.0	25							9.6	16.8	24.0
	5R		2.0	18		3.5	20		5.0	25									
		V	1.8	-		3.1	-		4.5	-									
	4	10R	5U	0.8	18		1.4	20		2.0	25								
H			0.8	18		1.4	20		2.0	25							2.4	4.2	6.0
5R		5D	0.8	-		1.4	-		2.0	-									
	10U	0.4	18		0.7	20		1.0	25										
5	20R	10D ⁽³⁾	0.4	-		0.7	-		1.0	-									
		5U	0.3	18		0.5	20		0.7	25							1.4	2.4	3.5
		5D	0.3	-		0.5	-		0.7	-									

(1) The photometric intensity values between test points must not be less than the lower specified minimum value of the two closest adjacent test points on a horizontal or vertical line.
 (2) If the sum of intensity values for all points in the zone is not less than the specified total value for the zone, the measured intensity value for each individual test point is not required to meet the minimum value.
 (3) Where taillamps are mounted with their axis of reference less than 750 mm above the road surface, photometry requirements below 5° down may be met at 5° down rather than at the specified maximum intensity over any area larger than that generated by a 0.25° radius, within a solid cone angle from 20°L to 20°R and from H to 10°U.
 (4) A taillamp shall not exceed the maximum intensity over any area larger than that generated by a 0.25° radius, within a solid cone angle from 20°L to 20°R and from H to 10°U.

TABLE IX: STOP LAMP PHOTOMETRY REQUIREMENTS

GROUP NUMBER	TEST POINT (degrees)	MINIMUM PHOTOMETRIC INTENSITY RATIO WHERE COMBINED WITH A TAIL LAMP ⁽⁵⁾	MINIMUM PHOTOMETRIC INTENSITY ⁽¹⁾⁽²⁾ (cd)			GROUP MINIMUM PHOTOMETRIC INTENSITY (cd)				
			Lighted Sections			Lighted Sections				
			1	2	3	1	2	3		
1	20L	5U	3	10	12	15	50	60	70	
		5D	3	10	12	15				
	5L	10U	3	16	19	22	50	60	70	
		10D ⁽⁴⁾	3	16	19	22				
2	10L	5U	3	30	35	40	100	115	135	
		H	3	40	47	55				
	V	5D	3	30	35	40	100	115	135	
		5U	5	70	82	95				
3	5L	H	3/5 ⁽⁶⁾	80	95	110	380	445	520	
			5	80	95	110				
	5R	V	5	80	95	110	380	445	520	
			3	70	82	95				
	4	10R	5U	3	30	35	40	100	115	135
			H	3	40	47	55			
5R		V	3	30	35	40	100	115	135	
			3	16	19	22				
5	5R	10D ⁽⁴⁾	3	16	19	22	50	60	70	
			3	16	19	22				
	20R	5U	3	10	12	15	50	60	70	
		5D	3	10	12	15				
MAXIMUM PHOTOMETRIC INTENSITY⁽³⁾			300	360	420					

(1) The measured values at each test point must not be less than 60% of the minimum value.
 (2) The photometric intensity values between test points must not be less than the lower specified minimum value of the two closest adjacent test points on a horizontal or vertical line.
 (3) The maximum photometric intensity must not occur over any area larger than that generated by a 0.5° radius within a solid angle defined by the test point range.
 (4) Where stop lamps are mounted with their axis of reference less than 750 mm above the road surface, photometry requirements below 5° down may be met at 5° down rather than at the specified required downward angle.
 (5) When a taillamp is combined with a stop lamp and the maximum luminous intensity of the taillamp is located below horizontal and within an area generated by a 0.5° radius around a test point (1.0° radius on lamps installed on a vehicle 2032 mm or more in overall width), the ratio for the test point may be computed by using the lowest value of the taillamp luminous intensity within the generated area.
 (6) Values preceded by a slash (/) apply only to lamps installed on multipurpose passenger vehicles, trucks, trailers, and buses of 2032 mm or more in overall width.

TABLE X.—SIDE MARKER LAMP PHOTOMETRY REQUIREMENTS

Test point (degrees)	Minimum photometric intensity (cd) ⁽²⁾ red lamps	Minimum photometric intensity (cd) ⁽²⁾ amber lamps
10U:		
45L ⁽¹⁾	0.25	0.62
V	0.25	0.62
45R ⁽¹⁾	0.25	0.62
H:		
45L ⁽¹⁾	0.25	0.62
V	0.25	0.62
45R ⁽¹⁾	0.25	0.62
10D: ⁽³⁾		
45L ⁽¹⁾	0.25	0.62
V	0.25	0.62
45R ⁽¹⁾	0.25	0.62

⁽¹⁾ Where a side marker lamp installed on a motor vehicle less than 30 feet in overall length and less than 80 inches (2 m) in overall width has the lateral angle nearest the other required side marker lamp on the same side of the vehicle reduced from 45° by design as specified by S7.4.13.2, the photometric intensity measurement may be met at the lesser angle.

⁽²⁾ The photometric intensity values between test points must not be less than the lower specified minimum value of the two closest adjacent test points on a horizontal or vertical line.

⁽³⁾ Where side marker lamps are mounted with their axis of reference less than 750 mm above the road surface, photometry requirements below 5° down may be met at 5° down rather than at the specified required downward angle.

TABLE XI.—CLEARANCE AND IDENTIFICATION LAMPS PHOTOMETRY REQUIREMENTS

Test point (degrees)	Minimum photometric intensity (cd) ⁽²⁾ red lamps	Minimum photometric intensity (cd) ⁽²⁾ amber lamps
10U:		
45L ⁽⁴⁾	0.25	0.62
V	0.25	0.62
45R ⁽⁴⁾	0.25	0.62
H:		
45L ⁽⁴⁾	0.25	0.62
V	0.25	0.62
45R ⁽⁴⁾	0.25	0.62
10D: ⁽¹⁾		
45L ⁽⁴⁾	0.25	0.62
V	0.25	0.62
45R ⁽⁴⁾	0.25	0.62
Maximum photometric intensity ⁽³⁾ (cd) red lamps	15	

⁽¹⁾ Where clearance lamps or identification lamps are mounted with their axis of reference less than 750mm above the road surface, photometry requirements below 5° down may be met at 5° down rather than at the specified required downward angle.

⁽²⁾ The photometric intensity values between test points must not be less than the lower specified minimum value of the two closest adjacent test points on a horizontal or vertical line.

⁽³⁾ When optically combined with a stop lamp or turn signal lamp, this maximum applies on or above the horizontal.

⁽⁴⁾ Where clearance lamps are installed at locations other than on the front and rear due to the necessity to indicate the overall width of the vehicle, or for protection from damage during normal operation of the vehicle, they need not meet the photometric intensity requirement at any test point that is 45° inboard.

TABLE XII: BACKUP LAMP PHOTOMETRY REQUIREMENTS

GROUP NUMBER	TEST POINT (degrees)	MAXIMUM PHOTOMETRIC INTENSITY (cd) ANY SINGLE LAMP	TWO LAMP SYSTEMS - EACH LAMP		SINGLE LAMP SYSTEM	
			MINIMUM PHOTOMETRIC INTENSITY (cd) ⁽¹⁾⁽⁴⁾	GROUP MINIMUM PHOTOMETRIC INTENSITY (cd)	MINIMUM PHOTOMETRIC INTENSITY (cd) ⁽¹⁾⁽⁴⁾	GROUP MINIMUM PHOTOMETRIC INTENSITY (cd)
1 ⁽²⁾⁽³⁾	45L	5U	300	45	30	90
		H	300		30	
		5D	-		30	
2 ⁽²⁾⁽³⁾	30L	H	300	50	50	100
		5D	-		50	
3	10L	10U	300	100	20	200
		5U	300		40	
		10U	300		30	
	V	5U	300		50	
		10U	300		20	
	10R	5U	300		40	
		H	300		100	
4	V	5D	-	360	100	720
		H	300		160	
	5D	-	160			
	H	300	100			
	5D	-	100			
5 ⁽²⁾⁽³⁾	30R	H	300	50	50	100
		5D	-		50	
6 ⁽²⁾⁽³⁾	45R	5U	300	45	30	90
		H	300		30	
		5D	-		30	

- (1) The photometric intensity values between test points must not be less than the lower specified minimum value of the two closest adjacent test points on a horizontal or vertical line.
- (2) When two lamps of the same or symmetrically opposite design are used, the tested photometric values along the vertical axis and the averages of the tested photometric values for the same horizontal test point left and right of vertical for one lamp must be used to determine compliance with the requirements.
- (3) When two lamps of differing designs are used, they must be tested individually and the tested photometric values added to determine the combined units compliance with twice the stated requirements.
- (4) If the sum of intensity values for all points in the zone is not less than the specified total value for the zone, the measured intensity value for each individual test point is not required to meet the minimum value.

GROUP NUMBER		TEST POINT (degrees)	MOTORCYCLE TURN SIGNAL LAMP ALTERNATIVE PHOTOMETRY REQUIREMENTS																																		
			MINIMUM PHOTOMETRIC INTENSITY RATIO WHERE COMBINED WITH A:		MINIMUM PHOTOMETRIC INTENSITY ⁽¹⁾⁽²⁾ (cd) FRONT TURN SIGNAL LAMP			MINIMUM PHOTOMETRIC INTENSITY ⁽¹⁾⁽²⁾ (cd) FRONT TURN SIGNAL LAMP			MINIMUM PHOTOMETRIC INTENSITY ⁽¹⁾⁽²⁾ (cd) RED REAR TURN SIGNAL LAMP			MINIMUM PHOTOMETRIC INTENSITY ⁽¹⁾⁽²⁾ (cd) RED REAR TURN SIGNAL LAMP			MINIMUM PHOTOMETRIC INTENSITY ⁽¹⁾⁽²⁾ (cd) AMBER REAR TURN SIGNAL LAMP			MINIMUM PHOTOMETRIC INTENSITY ⁽¹⁾⁽²⁾ (cd) AMBER REAR TURN SIGNAL LAMP																	
			PARKING LAMP	TAIL LAMP ⁽⁵⁾	Lighted Sections			Lighted Sections			Lighted Sections			Lighted Sections			Lighted Sections			Lighted Sections																	
1	20L	5U	3	3	12.5	15	17.5	1	2	3	5	6	7.5	1	2	3	7.5	10	12.5	1	2	3	7.5	10	12.5	1	2	3	7.5	10	12.5						
			-	-	12.5	15	17.5	65	77.5	90	5	6	7.5	25	30	35	5	6	7.5	13	15	17.5	13	15	17.5	25	30	35	5	6	7.5	13	15	17.5			
			3	3	20	24	27.5				8	9.5	11				8	9.5	11				15	17.5	20	20	23.5	27.5	50	57.5	67.5	25	27.5	32.5			
			-	-	20	24	27.5				8	9.5	11				8	9.5	11				15	17.5	20	20	23.5	27.5	50	57.5	67.5	25	27.5	32.5			
2	10L	H	3	3	37.5	44	50	125	147.5	170				35	41	47.5	40	47.5	55	190	222.5	260	65	75	87.5	55	65	75	87.5	55	65	75	87.5				
			5	5	87.5	102.5	117.5				40	47.5	55				40	47.5	55				35	41	47.5	35	41	47.5	25	27.5	32.5	25	27.5	32.5			
			5	5	100	120	137.5	475	565	647.5				40	47.5	55				40	47.5	55				40	47.5	55				65	75	87.5			
			5	5	100	120	137.5							40	47.5	55				40	47.5	55				35	41	47.5	35	41	47.5	25	27.5	32.5	25	27.5	32.5
3	V	5R	3	3	87.5	102.5	117.5	125	147.5	170				15	17.5	20	190	222.5	260	50	57.5	67.5	65	75	87.5	55	65	75	87.5	55	65	75	87.5				
			5	5	100	120	137.5	475	565	647.5				40	47.5	55				40	47.5	55				40	47.5	55				65	75	87.5			
			5	5	100	120	137.5							40	47.5	55				40	47.5	55				35	41	47.5	35	41	47.5	25	27.5	32.5	25	27.5	32.5
			5	5	100	120	137.5							40	47.5	55				40	47.5	55				35	41	47.5	35	41	47.5	25	27.5	32.5	25	27.5	32.5
4	10R	H	3	3	37.5	44	50	125	147.5	170				15	17.5	20	50	57.5	67.5	50	57.5	67.5	65	75	87.5	55	65	75	87.5	55	65	75	87.5				
			5	5	87.5	102.5	117.5				15	17.5	20	190	222.5	260	50	57.5	67.5	50	57.5	67.5	65	75	87.5	55	65	75	87.5	55	65	75	87.5				
			5	5	100	120	137.5	475	565	647.5				40	47.5	55				40	47.5	55				40	47.5	55				65	75	87.5			
			5	5	100	120	137.5							40	47.5	55				40	47.5	55				35	41	47.5	35	41	47.5	25	27.5	32.5	25	27.5	32.5
5	20R	5D	3	3	12.5	15	17.5	65	77.5	90				8	9.5	11	25	30	35	50	57.5	67.5	65	75	87.5	55	65	75	87.5	55	65	75	87.5				
			5	5	12.5	15	17.5	65	77.5	90				8	9.5	11	25	30	35	50	57.5	67.5	65	75	87.5	55	65	75	87.5	55	65	75	87.5				
			3	3	20	24	27.5				8	9.5	11				8	9.5	11				15	17.5	20	15	17.5	20	15	17.5	20	15	17.5	20			
			3	3	12.5	15	17.5				8	9.5	11				8	9.5	11				15	17.5	20	15	17.5	20	15	17.5	20	15	17.5	20			
MAXIMUM PHOTOMETRIC INTENSITY⁽³⁾													300	360	420																						

(1) The measured values at each test point must not be less than 60% of the minimum value.
 (2) The photometric intensity values between test points must not be less than the lower specified minimum value of the two closest adjacent test points on a horizontal or vertical line.
 (3) The maximum photometric intensity must not occur over any area larger than that generated by a 0.5° radius within a solid angle defined by the test point range.
 (4) Where turn signal lamps are mounted with their axis of reference less than 750 mm above the road surface, photometry requirements below 5° down may be met at 5° down rather than at the specified required downward angle.
 (5) When a taillamp is combined with a rear turn signal lamp and the maximum luminous intensity of the taillamp is located below horizontal and within an area generated by a 0.5° radius around a test point the ratio for the test point may be computed by using the lowest value of the taillamp luminous intensity within the generated area.

TABLE XIII-b: MOTOR DRIVEN CYCLE STOP LAMP ⁽³⁾ ALTERNATIVE PHOTOMETRY REQUIREMENTS		GROUP MINIMUM PHOTOMETRIC INTENSITY (cd) MOTOR DRIVEN CYCLE STOP LAMP			
GROUP NUMBER	TEST POINT (degrees)	MINIMUM PHOTOMETRIC INTENSITY RATIO WHERE A MOTOR DRIVEN CYCLE STOP LAMP IS COMBINED WITH A TAIL LAMP ⁽⁴⁾	Lighted Sections		
			1	2	3
1	20L	3	26	31	36
	5D	3			
	10U	3			
	10D ⁽²⁾	3			
2	5U	3	50	59	69
	H	3			
	5D	3			
	V	5			
3	5L	5	190	226	261
	V	5			
	5R	5			
	V	3			
4	10R	3	50	59	69
	H	3			
	5D	3			
	10U	3			
5	5R	3	26	31	36
	20R	3			
	5U	3			
	5D	3			
MAXIMUM PHOTOMETRIC INTENSITY⁽¹⁾			300	360	420

- (1) The maximum photometric intensity must not occur over any area larger than that generated by a 0.5° radius within a solid angle defined by the test point range.
- (2) Where stop lamps are mounted with their axis of reference less than 750 mm above the road surface, photometry requirements below 5° down may be met at 5° down rather than at the specified required downward angle.
- (3) Requirements for a motor-driven cycle whose speed attainable in 1 mile is 30 mph or less.
- (4) When a taillamp is combined with a stop lamp and the maximum luminous intensity of the taillamp is located below horizontal and within an area generated by a 0.5° radius around a test point the ratio for the test point may be computed by using the lowest value of the taillamp luminous intensity within the generated area

TABLE XIV: PARKING LAMP PHOTOMETRY REQUIREMENTS

GROUP NUMBER	TEST POINT (degrees)		MINIMUM PHOTOMETRIC INTENSITY ⁽¹⁾⁽²⁾ (cd)	MAXIMUM PHOTOMETRIC INTENSITY (cd)	GROUP MINIMUM PHOTOMETRIC INTENSITY (cd)
1	20L	5U	0.4	125	2.4
		5D	0.4	250	
	5L	10U	0.8	125	
		10D ⁽³⁾	0.8	250	
2	10L	5U	0.8	125	3.0
		H	1.4	125	
	V	5D	0.8	250	
		5U	2.8	125	
3	5L	H	3.6	125	16.8
			4.0	125	
	5R	V	3.6	125	
			2.8	250	
	10R	5U	0.8	125	
		H	1.4	125	
5	5R	10U	0.8	125	2.4
		10D ⁽³⁾	0.8	250	
	20R	5U	0.4	125	
		5D	0.4	250	

(1) The photometric intensity values between test points must not be less than the lower specified minimum value of the two closest adjacent test points on a horizontal or vertical line.

(2) If the sum of intensity values for all points in the zone is not less than the specified total value for the zone, the measured intensity value for each individual test point is not required to meet the minimum value.

(3) Where parking lamps are mounted with their axis of reference less than 750 mm above the road surface, photometry requirements below 5° down may be met at 5° down rather than at the specified required downward angle.

TABLE XV: HIGH-MOUNTED STOP LAMP PHOTOMETRY REQUIREMENTS			
GROUP NUMBER	TEST POINT (degrees)	MINIMUM PHOTOMETRIC INTENSITY⁽¹⁾⁽²⁾⁽³⁾ (cd)	GROUP MINIMUM PHOTOMETRIC INTENSITY⁽³⁾ (cd)
1	5U	V	25
	H	5L	25
	H	V	25
	H	5R	25
	5D	V	25
2	5U	5R	25
	5U	10R	16
	H	10R	16
	5D	10R	16
	5D	5R	25
3	5U	5L	25
	5U	10L	16
	H	10L	16
	5D	10L	16
	5D	5L	25
4	10U	10L	8
	10U	V	16
	10U	10R	8
MAXIMUM PHOTOMETRIC INTENSITY⁽⁴⁾			160

(1) The photometric intensity values between test points must not be less than the lower specified minimum value of the two closest adjacent test points on a horizontal or vertical line.

(2) The photometric intensity at each test point must not be less than 60% of the specified minimum value when considering overall group or zone photometry tables.

(3) Where a pair of lamps identical in size and shape are used due to vehicle construction, they together must meet photometric requirements.

(4) The maximum photometric intensity must not occur over any area larger than that generated by a 0.25° radius within a solid cone angle within the rectangle bounded by test points 10U-10L, 10U-10R, 5D-10L, and 5D-10R.

TABLE XVI-a.—REFLEX REFLECTOR PHOTOMETRY REQUIREMENTS

Observation angle (degrees)	Entrance angle (degrees)	Minimum performance					
		Red reflectors		Amber reflectors		White reflectors	
		(cd/incident ft-c)	(mcd/lux)	(cd/incident ft-c)	(mcd/lux)	(cd/incident ft-c)	(mcd/lux)
0.2	0	4.5	420	11.25	1050	18	1680
	10U	3.0	280	7.5	700	12	1120
	10D ⁽¹⁾	3.0	280	7.5	700	12	1120
	20L	1.5	140	3.75	350	6	560
	20R	1.5	140	3.75	350	6	560
1.5	0	0.07	6	0.175	15	0.28	24
	10U	0.05	5	0.125	12.5	0.2	20
	10D ⁽¹⁾	0.05	5	0.125	12.5	0.2	20
	20L	0.03	3	0.075	7.5	0.12	12
	20R	0.03	3	0.075	7.5	0.12	12

⁽¹⁾ Where reflex reflectors are mounted with their axis of reference less than 750 mm above the road surface, photometry requirements below 5° down may be met at 5° down rather than at the required specified downward angle.

TABLE XVI-b.—ADDITIONAL PHOTOMETRY REQUIREMENTS FOR CONSPICUITY REFLEX REFLECTORS

Observation angle (degrees)	Entrance angle (degrees)	Minimum performance		
		Red (mcd/lux)	White horizontal orientation (mcd/lux)	White vertical orientation (mcd/lux)
0.2	0	300	1250	1680
	20L TO 20R			560
	30L TO 30R	300	1250	
	45L TO 45R	75	300	
	10U TO 10D			1120

TABLE XVI-c.—RETROREFLECTIVE SHEETING PHOTOMETRY REQUIREMENTS

Observation angle (degrees)	Entrance angle (degrees)	Minimum performance					
		Grade dot-C2		Grade dot-C3		Grade dot-C4	
		White	Red	White	Red	White	Red
		(cd/lux/sq m)	(cd/lux/sq m)	(cd/lux/sq m)	(cd/lux/sq m)	(cd/lux/sq m)	(cd/lux/sq m)
0.2	-4	250	60	165	40	125	30
	30	250	60	165	40	125	30
	45	60	15	40	10	30	8
0.5	-4	65	15	43	10	33	8
	30	65	15	43	10	33	8
	45	15	4	10	3	8	2

TABLE XVII.—SCHOOL BUS SIGNAL LAMP PHOTOMETRY REQUIREMENTS

Test point (degrees)	Minimum photometric intensity (cd) ⁽²⁾ red lamps	Minimum photometric intensity (cd) amber lamps
5U:		
20L	150	375
10L	300	750
5L	300	750
V	300	750
5R	300	750
10R	300	750
20R	150	375
H:		
30L	30	75
20L	180	450
10L	400	1000
5L	500	1250

TABLE XVII.—SCHOOL BUS SIGNAL LAMP PHOTOMETRY REQUIREMENTS—Continued

Test point (degrees)	Minimum photo- metric intensity (cd) ⁽²⁾ red lamps	Minimum photo- metric intensity (cd) amber lamps
V	600	1500
5R	500	1250
10R	400	1000
20R	180	450
30R	30	75
5D:		
30L	30	75
20L	200	500
10L	300	750
5L	450	1125
V	450	1125
5R	450	1125
10R	300	750
20R	200	500
30R	30	75
10D: ⁽¹⁾		
5L	40	100
V	40	100
5R	40	100

⁽¹⁾ Where school bus signal lamps are mounted with their axis of reference less than 750 mm above the road surface, photometry requirements below 5° down may be met at 5° down rather than at the specified required downward angle.

⁽²⁾ The photometric intensity values between test points must not be less than the lower specified minimum value of the two closest adjacent test points on a horizontal or vertical line.

TABLE XVIII: HEADLAMP UPPER BEAM PHOTOMETRY REQUIREMENTS						
TEST POINT (degrees)	UPPER BEAM #1 (UB1)		UPPER BEAM #2 (UB2)		UPPER BEAM #3 (UB3)	
	MAXIMUM PHOTOMETRIC INTENSITY (cd)	MINIMUM PHOTOMETRIC INTENSITY (cd)	MAXIMUM PHOTOMETRIC INTENSITY (cd)	MINIMUM PHOTOMETRIC INTENSITY (cd)	MAXIMUM PHOTOMETRIC INTENSITY (cd)	MINIMUM PHOTOMETRIC INTENSITY (cd)
2U	-	1,500	-	1,500	-	1,000
1U	-	5,000	-	5,000	-	2,000
H	70,000	40,000	75,000	40,000	75,000	20,000
H	-	15,000	-	15,000	-	10,000
H	-	5,000	-	5,000	-	3,250
H	-	3,000	-	3,000	-	1,500
H	-	1,500	-	1,500	-	750
1.5D	-	5,000	-	5,000	-	5,000
1.5D	-	2,000	-	2,000	-	1,500
2.5D	-	2,500	-	2,500	-	2,500
2.5D	-	1,000	-	1,000	-	750
4D	5,000	-	12,000	-	5,000	-
UPPER BEAM #4 (UB4)						
2U	-	750	-	750	-	1,500
1U	-	3,000	-	2,000	-	5,000
H	60,000	18,000	15,000	7,000	70,000	40,000
H	-	12,000	-	3,000	-	15,000
H	-	3,000	-	2,000	-	5,000
H	-	2,000	-	1,000	-	3,000
H	-	750	-	750	-	1,500
1.5D	-	3,000	-	2,000	-	5,000
1.5D	-	1,250	-	750	-	1,000
2.5D	-	1,500	-	1,000	-	-
2.5D	-	600	-	400	-	-
4D	5,000	-	2,500	-	5,000	-
UPPER BEAM #5 (UB5)						
2U	-	750	-	750	-	1,500
1U	-	3,000	-	2,000	-	5,000
H	60,000	18,000	15,000	7,000	70,000	40,000
H	-	12,000	-	3,000	-	15,000
H	-	3,000	-	2,000	-	5,000
H	-	2,000	-	1,000	-	3,000
H	-	750	-	750	-	1,500
1.5D	-	3,000	-	2,000	-	5,000
1.5D	-	1,250	-	750	-	1,000
2.5D	-	1,500	-	1,000	-	-
2.5D	-	600	-	400	-	-
4D	5,000	-	2,500	-	5,000	-
UPPER BEAM #6 (UB6)						
2U	-	750	-	750	-	1,500
1U	-	3,000	-	2,000	-	5,000
H	60,000	18,000	15,000	7,000	70,000	40,000
H	-	12,000	-	3,000	-	15,000
H	-	3,000	-	2,000	-	5,000
H	-	2,000	-	1,000	-	3,000
H	-	750	-	750	-	1,500
1.5D	-	3,000	-	2,000	-	5,000
1.5D	-	1,250	-	750	-	1,000
2.5D	-	1,500	-	1,000	-	-
2.5D	-	600	-	400	-	-
4D	5,000	-	2,500	-	5,000	-

TABLE XIX-a: HEADLAMP LOWER BEAM PHOTOMETRY REQUIREMENTS

TEST POINT (degrees)	LOWER BEAM # 1M (LB1M)		LOWER BEAM # 1V (LB1V)		LOWER BEAM # 2M (LB2M)		LOWER BEAM # 2V (LB2V)	
	MAXIMUM PHOTOMETRIC INTENSITY (cd)	MINIMUM PHOTOMETRIC INTENSITY (cd)	MAXIMUM PHOTOMETRIC INTENSITY (cd)	MINIMUM PHOTOMETRIC INTENSITY (cd)	MAXIMUM PHOTOMETRIC INTENSITY (cd)	MINIMUM PHOTOMETRIC INTENSITY (cd)	MAXIMUM PHOTOMETRIC INTENSITY (cd)	MINIMUM PHOTOMETRIC INTENSITY (cd)
(1) 10U to 90U	125	-	125	-	125	-	125	-
4U	-	64	-	64	-	64	-	64
2U	-	135	-	135	-	135	-	135
1.5U	-	200	-	200	-	200	-	200
1.5U	1,400	-	1,400	-	1,400	-	1,400	-
1U	700	-	700	-	700	-	700	-
0.5U	1,000	-	1,000	-	1,000	-	1,000	-
0.5U	2,700	500	2,700	500	2,700	500	2,700	500
H	5,000	-	5,000	-	-	-	-	-
H	-	135	-	135	-	135	-	135
H	-	64	-	64	-	64	-	64
0.5D	3,000	-	-	-	3,000	-	-	-
0.5D	20,000	10,000	-	-	20,000	10,000	-	-
0.6D	-	-	-	10,000	-	-	-	10,000
0.86D	-	-	-	4,500	-	-	-	4,500
0.86D	-	-	12,000	1,800	-	-	12,000	1,800
1D	-	1,000	-	-	-	1,000	-	-
1.5D	-	15,000	-	15,000	-	15,000	-	15,000
1.5D	-	1,000	-	-	-	1,000	-	-
2D	-	-	-	1,250	-	-	-	1,250
2D	-	850	-	1,000	-	850	-	1,000
2.5D	-	-	-	-	-	-	-	-
2.5D	-	-	-	-	-	-	-	-
4D	7,000	-	10,000	-	-	-	-	-
4D	12,500	-	12,500	-	12,500	-	12,500	-
4D	-	-	-	300	-	-	-	300

(1) These test points are boundaries, all test points that fall into the area defined by these points must meet the listed photometry requirement.

TABLE XIX-b: HEADLAMP LOWER BEAM PHOTOMETRY REQUIREMENTS

TEST POINT (degrees)	LOWER BEAM #3 M (LB3M)		LOWER BEAM #3 V (LB3V)		LOWER BEAM #4M (LB4M)		LOWER BEAM #5M (LB5M)	
	MAXIMUM PHOTOMETRIC INTENSITY (cd)	MINIMUM PHOTOMETRIC INTENSITY (cd)	MAXIMUM PHOTOMETRIC INTENSITY (cd)	MINIMUM PHOTOMETRIC INTENSITY (cd)	MAXIMUM PHOTOMETRIC INTENSITY (cd)	MINIMUM PHOTOMETRIC INTENSITY (cd)	MAXIMUM PHOTOMETRIC INTENSITY (cd)	MINIMUM PHOTOMETRIC INTENSITY (cd)
(1) 10U to 90U	125	-	125	-	125	-	125	-
4U	-	64	-	64	-	64	-	64
2U	-	135	-	135	-	135	-	135
1.5U	-	200	-	200	-	200	-	200
1.5U	1,400	-	1,400	-	1,400	-	1,400	-
1U	700	-	700	-	700	-	700	-
0.5U	1,000	-	1,000	-	1,000	-	1,000	-
0.5U	2,700	500	2,700	500	2,700	500	2,700	500
H	-	-	-	-	-	-	5,000	-
H	-	135	-	135	-	135	-	135
H	-	64	-	64	-	64	-	64
0.5D	2,500	-	-	-	2,500	-	3,000	-
0.5D	20,000	8,000	-	-	20,000	8,000	20,000	10,000
0.6D	-	-	-	10,000	-	-	-	-
0.86D	-	-	-	4,500	-	-	-	-
0.86D	-	-	12,000	1,800	-	-	-	-
1D	-	750	-	-	-	750	-	1,000
1.5D	-	15,000	-	15,000	-	15,000	-	15,000
1.5D	-	750	-	-	-	750	-	1,000
2D	-	-	-	1,250	-	-	-	-
2D	-	700	-	1,000	-	700	-	850
2.5D	-	-	-	-	-	-	-	2,500
2.5D	-	-	-	-	-	-	-	1,000
4D	-	-	-	-	-	-	7,000	-
4D	12,500	-	12,500	-	12,500	-	12,500	-
4D	-	-	-	300	-	-	-	-

(1) These test points are boundaries, all test points that fall into the area defined by these points must meet the listed photometry requirement.

TEST POINT (degrees)		MAXIMUM PHOTOMETRIC INTENSITY (cd)	LOWER BEAM # 4 V (LB4V) MINIMUM PHOTOMETRIC INTENSITY (cd)
(1) 10U to 90U	(1) 90L to 90R	125	-
4U	8L & 8R	-	64
2U	4L	-	135
1.5U	1R to 3R	-	200
1.5U	1R to R	1,400	-
1U	1.5L to L	700	-
0.5U	1.5L to L	1,000	-
0.5U	1R to 3R	2,700	500
H	V	5,000	-
H	4L	-	135
H	8L	-	64
0.5D	1.5L to L	-	-
0.5D	1.5R	-	-
0.6D	1.3R	-	10,000
0.86D	V	-	4,500
0.86D	3.5L	12,000	1,800
1D	6L	-	-
1.5D	2R	-	15,000
1.5D	9L & 9R	--	-
2D	9L & 9R	-	1,250
2D	15L & 15R	-	1,000
2.5D	V	-	2,500
2.5D	12L & 12R	-	1,000
4D	V	10,000	-
4D	4R	12,500	-
4D	20L & 20R	-	300

(1) These test points are boundaries, all test points that fall into the area defined by these points must meet the listed photometry requirement.

TABLE XX: MOTORCYCLE AND MOTOR DRIVEN CYCLE HEADLAMP PHOTOMETRY REQUIREMENTS							
LOWER BEAM							
TEST POINT (degrees)		MOTORCYCLE		MOTOR DRIVEN CYCLE		MOTOR DRIVEN CYCLE with Single Lamp System	
		MAXIMUM PHOTOMETRIC INTENSITY (cd)	MINIMUM PHOTOMETRIC INTENSITY (cd)	MAXIMUM PHOTOMETRIC INTENSITY (cd)	MINIMUM PHOTOMETRIC INTENSITY (cd)	MAXIMUM PHOTOMETRIC INTENSITY (cd)	MINIMUM PHOTOMETRIC INTENSITY (cd)
1.5U	1R to R	1,400	-	1,400	-	-	-
1.5U	1R to 3R	-	-	-	-	1,400	-
1U	1.5L to L	700	-	700	-	700	-
0.5U	1.5L to L	1,000	-	1,000	-	1,000	-
0.5U	1R to 3R	2,700	-	2,700	-	2,700	-
1.5D	9L and 9R	-	700	-	-	-	-
2D	V	-	7,000	-	5,000	-	4,000
2D	3L and 3R	-	4,000	-	3,000	-	3,000
2D	6L and 6R	-	1,500	-	1,500	-	1,500
2D	12L and 12R	-	700	-	-	-	-
3D	6L and 6R	-	800	-	800	-	-
4D	V	-	2,000	-	2,000	-	1,000
4D	4R	12,500	-	12,500	-	12,500	-
UPPER BEAM							
TEST POINT (degrees)		MOTORCYCLE		MOTOR DRIVEN CYCLE			
		MAXIMUM PHOTOMETRIC INTENSITY (cd)	MINIMUM PHOTOMETRIC INTENSITY (cd)	MAXIMUM PHOTOMETRIC INTENSITY (cd)	MINIMUM PHOTOMETRIC INTENSITY (cd)		
2U	V	-	1,000	-	-		
1U	3L and 3R	-	2,000	-	2,000		
H	V	-	12,500	-	10,000		
0.5D	V	-	20,000	-	20,000		
0.5D	3L and 3R	-	10,000	-	5,000		
0.5D	6L and 6R	-	3,300	-	2,000		
0.5D	9L and 9R	-	1,500	-	-		
0.5D	12L and 12R	-	800	-	-		
1D	V	-	17,500	-	15,000		
2D	V	-	5,000	-	5,000		
3D	V	-	2,500	-	2,500		
3D	6L and 6R	-	-	-	800		
3D	9L and 9R	-	1,500	-	-		
3D	12L and 12R	-	300	-	-		
4D	V	-	1,500	-	-		
4D	V	7,500	-	7,500	-		
ANYWHERE IN BEAM		75,000	-	75,000	-		

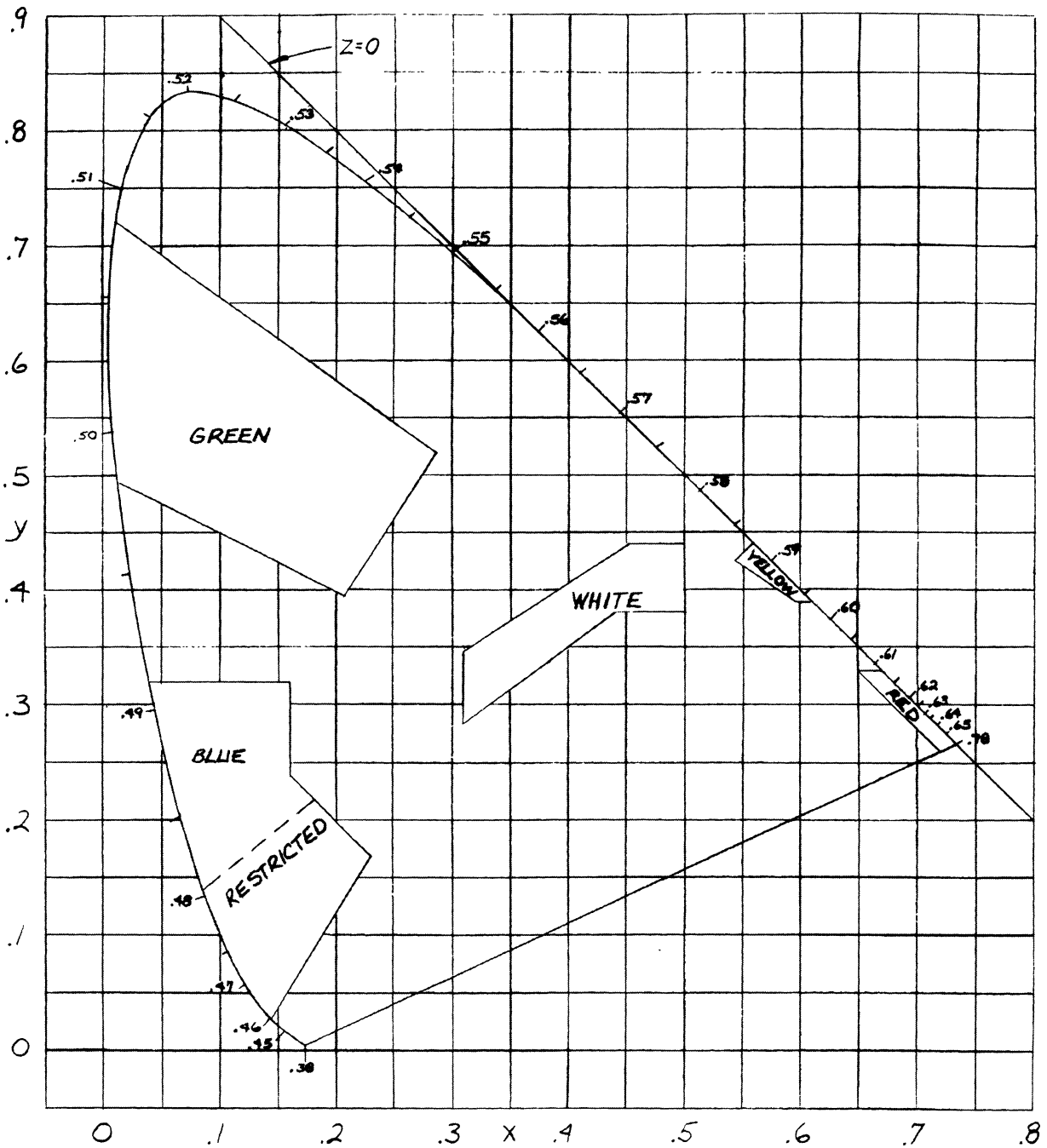

CHROMATICITY DIAGRAM

FIGURE 1

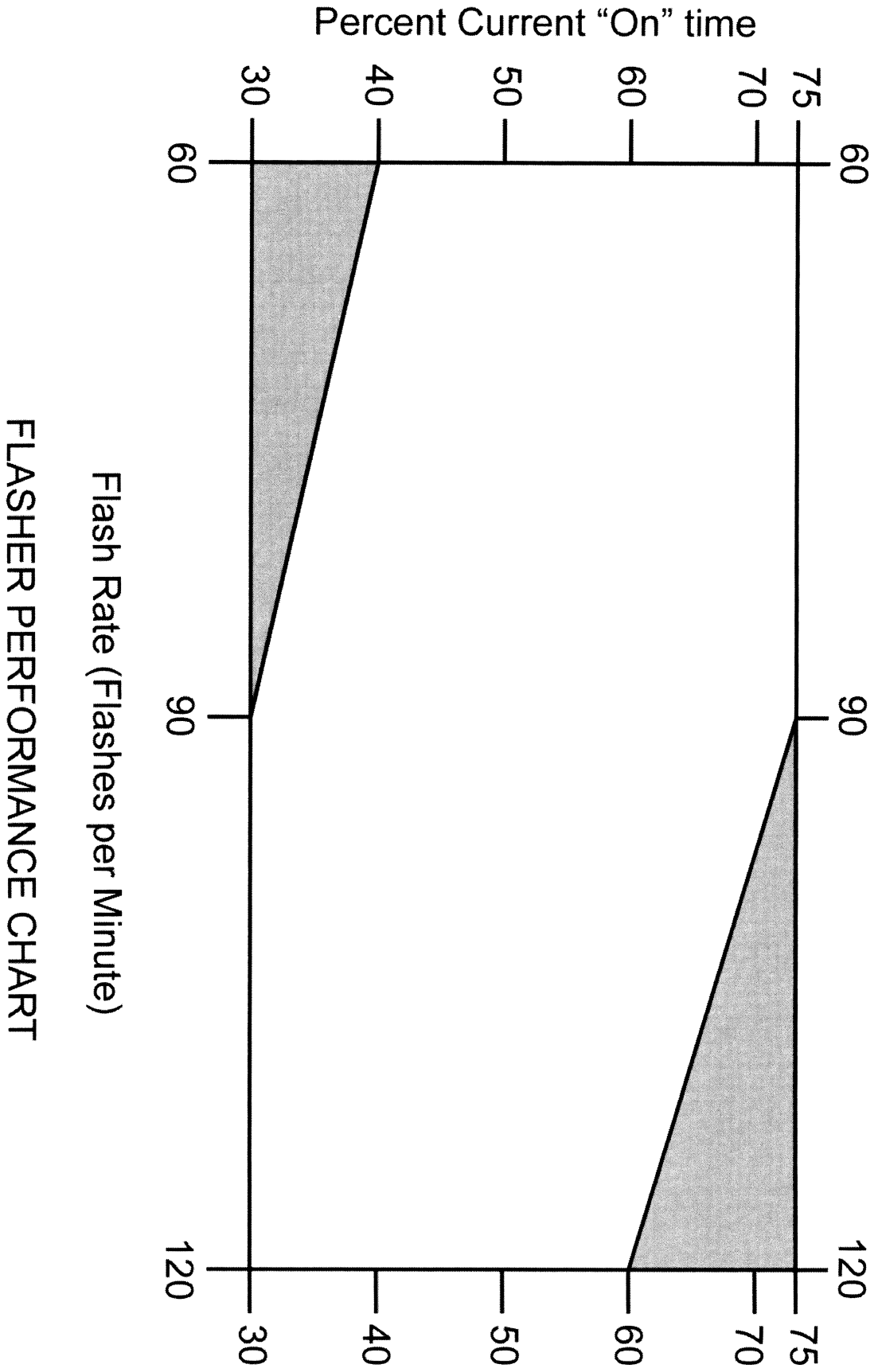
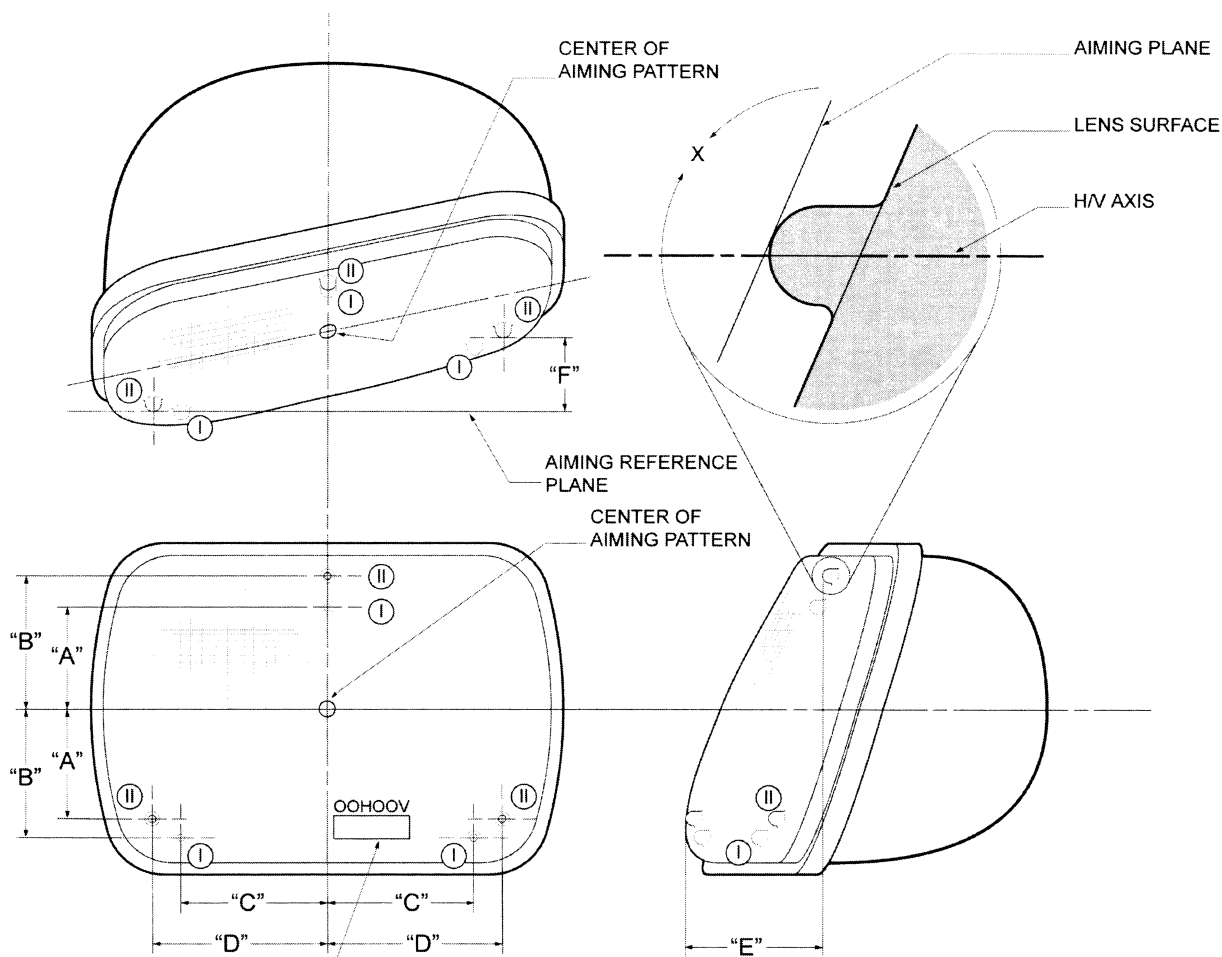

FIGURE 2



MECHANICAL AIMING DEVICE LOCATING PLATE SETTINGS FOR THE ADJUSTABLE LEGS

Notes:

Group I or Group II aiming pad locations may be used

Group I aiming pad location (front view) is that prescribed for 2B1 sealed beam units

Group II aiming pad location (front view) is that prescribed for 1A1/2A1 sealed beam units

Letter	MM	Inches
A	42.16 ± 0.25	1.660 ± 0.010
B	60.05 ± 1.00	2.364 ± 0.039
C	64.0 ± 1.00	2.520 ± 0.039
D	68.58 ± 0.51	2.700 ± 0.020
E	Mechanical aiming device locating plate setting for the vertical adjustable leg. (Millimeters)	
F	Mechanical aiming device locating plate setting for the horizontal adjustable leg. (Millimeters)	

REPLACEABLE BULB HEADLAMP AIM PADS

FIGURE 3

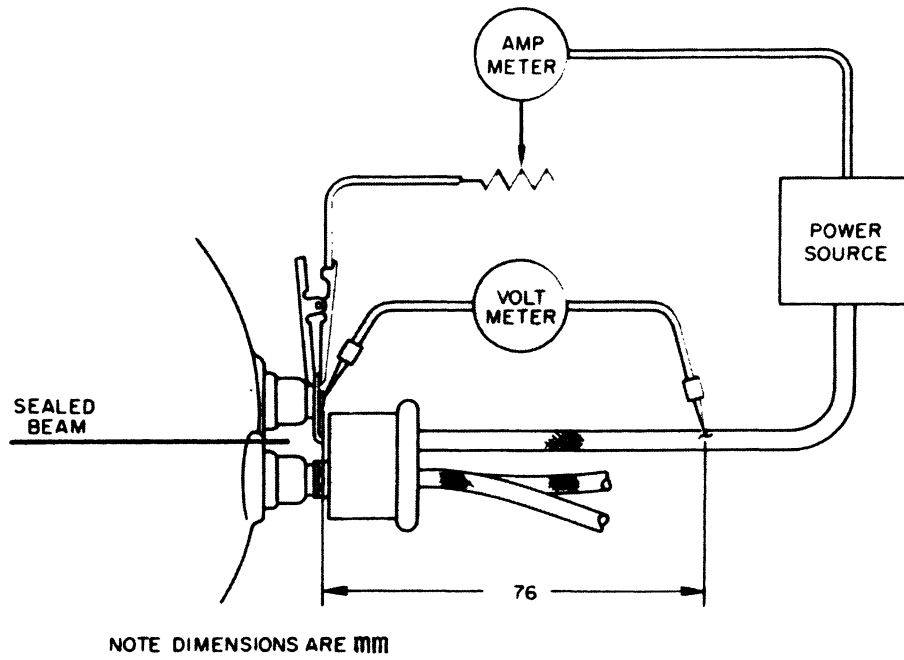

HEADLAMP CONNECTOR TEST SETUP

FIGURE 4

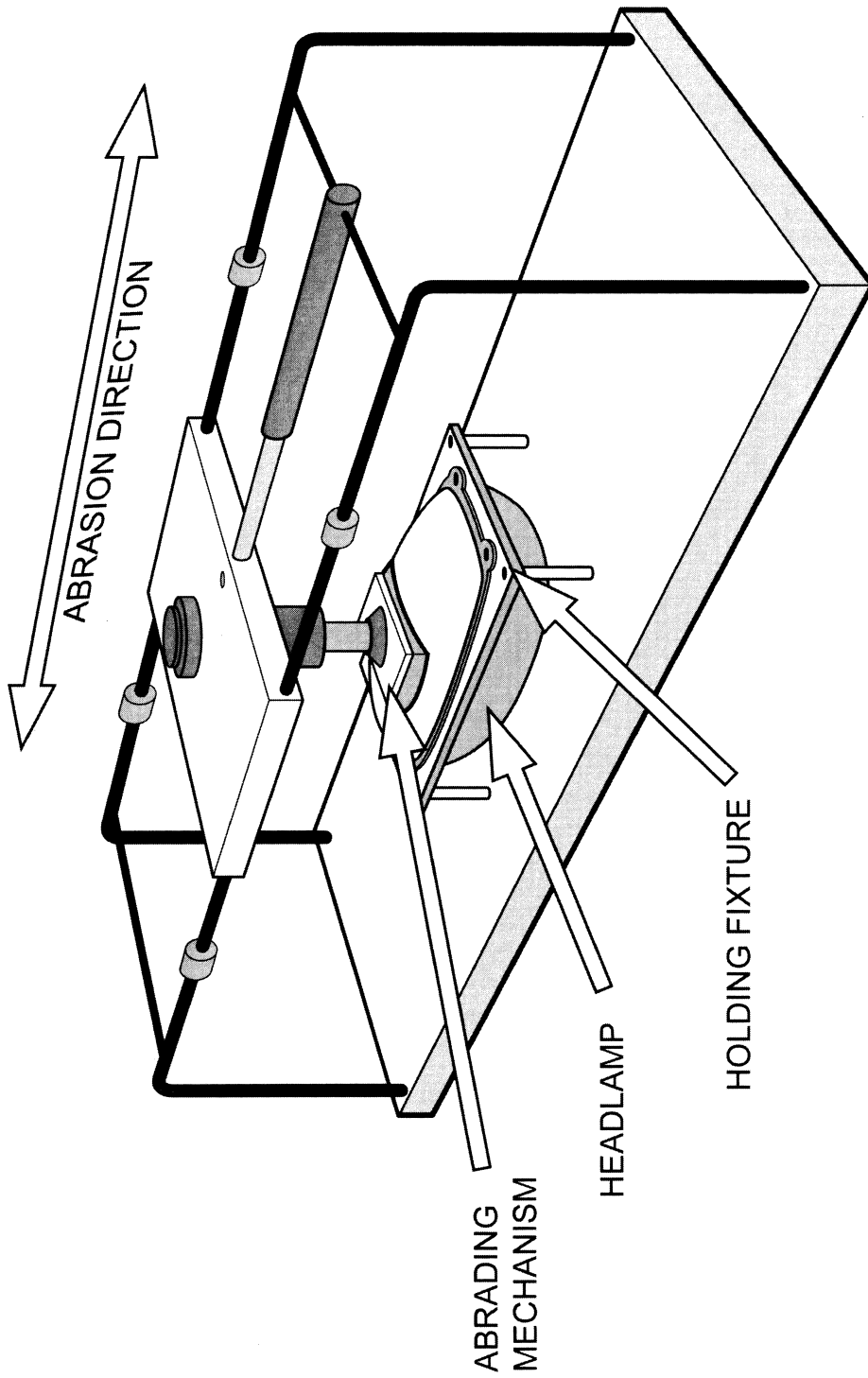

HEADLAMP ABRASION TEST FIXTURE

FIGURE 5

Ambient temperature transition rates:
Minimum 0.6° C per minute
Maximum 4° C per minute

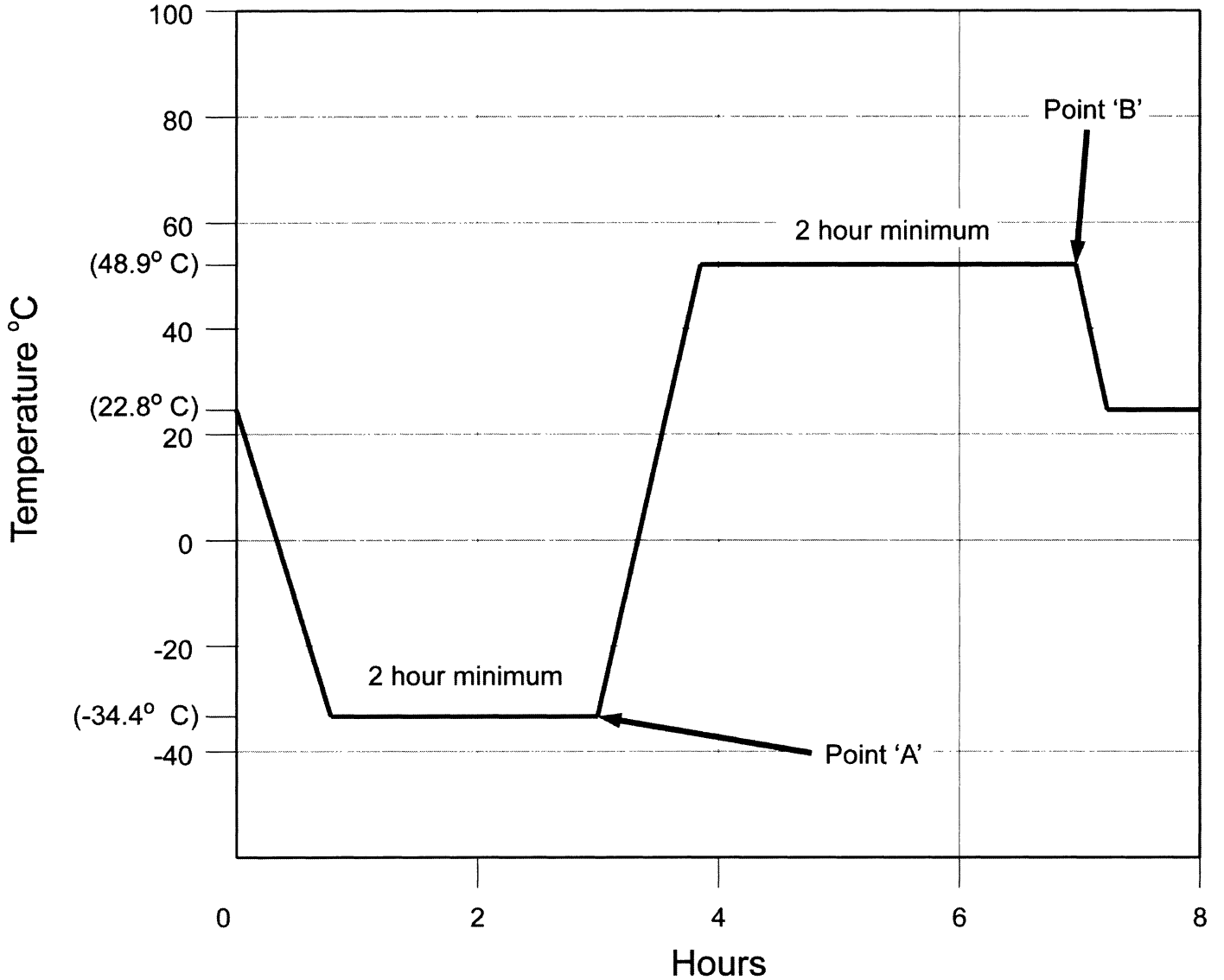

Note: Ambient conditions 23° C ± 4° and 30% RH ± 10%

THERMAL CYCLE PROFILE

FIGURE 6

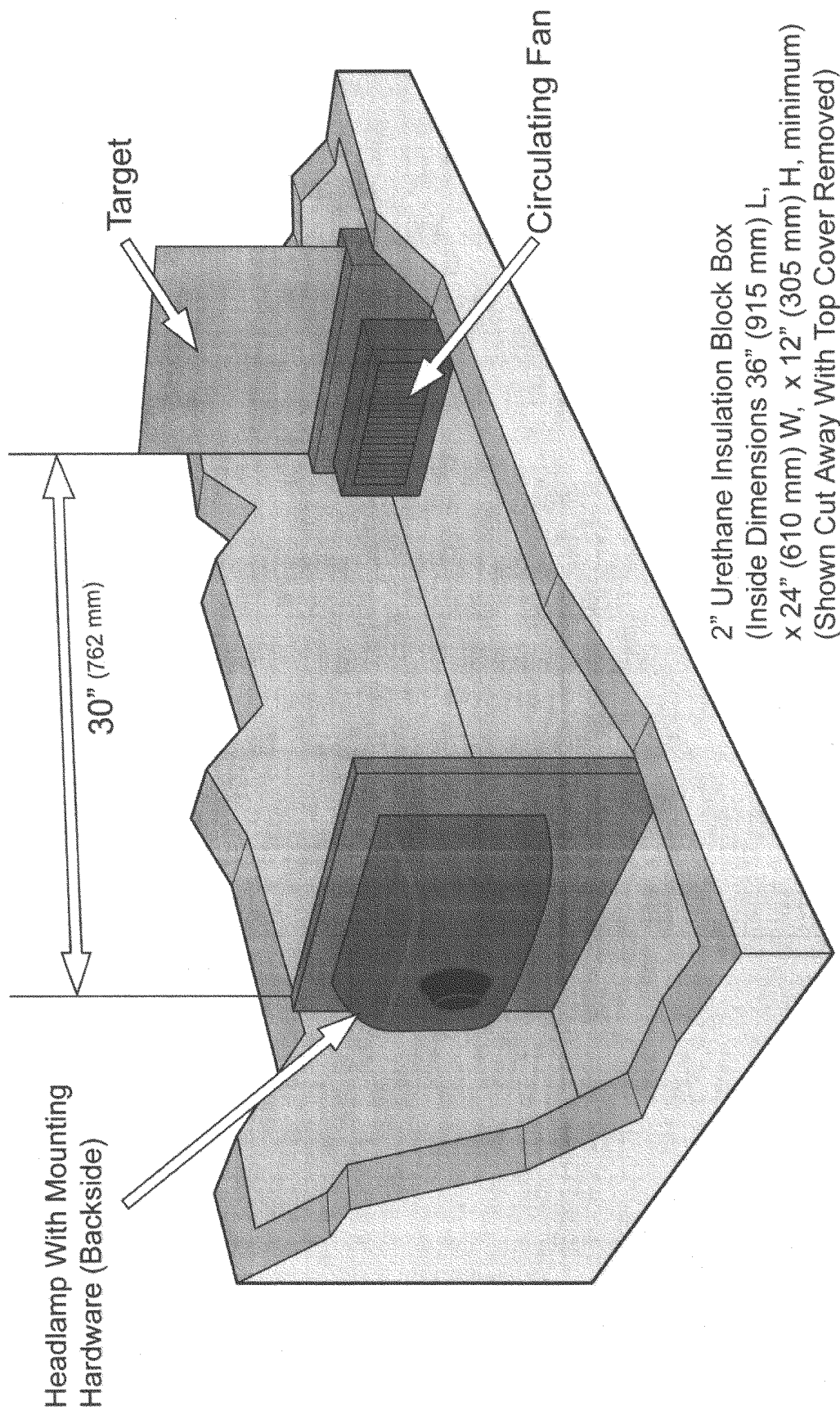

DIRT / AMBIENT TEST SETUP

FIGURE 7

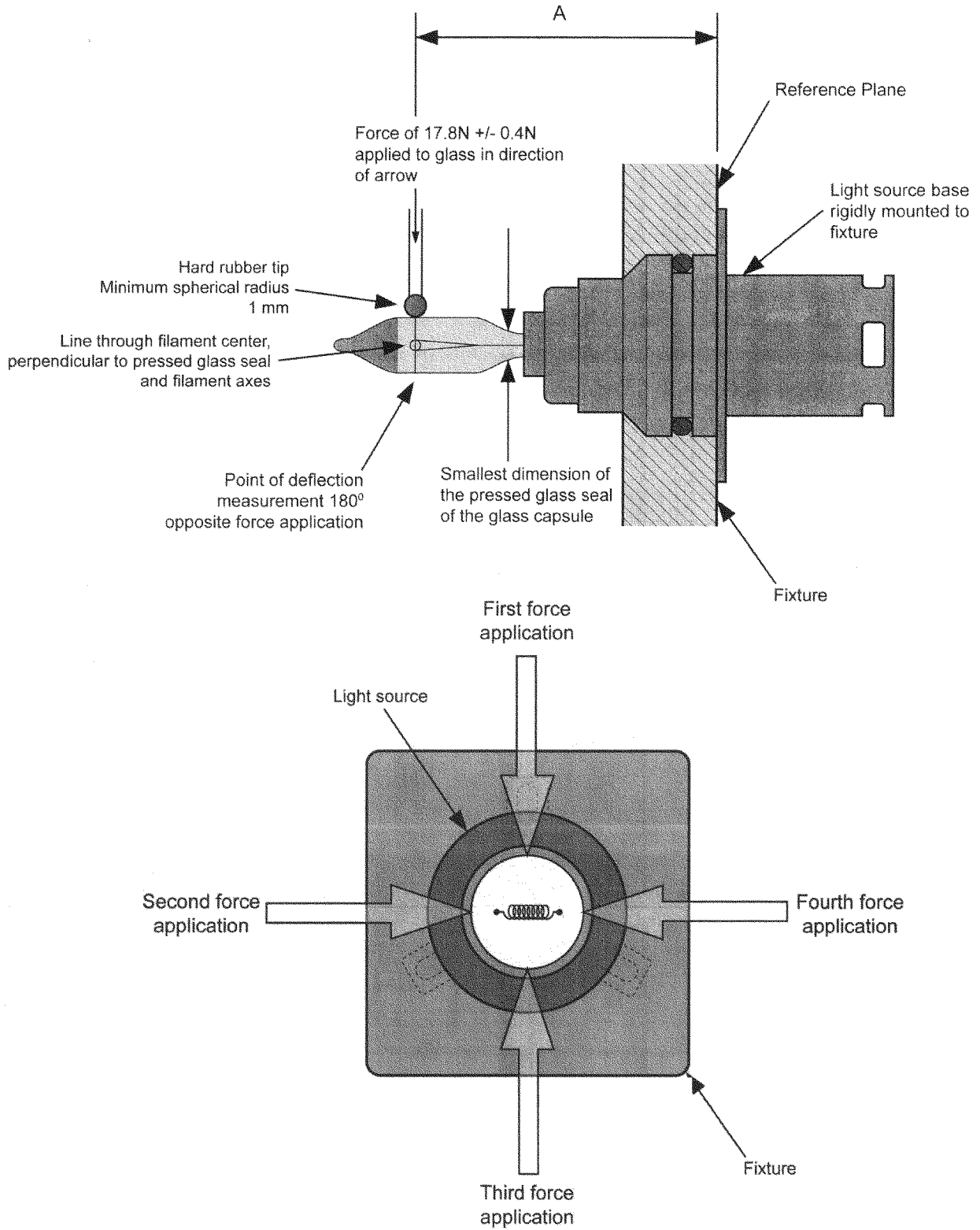

REPLACEABLE LIGHT SOURCE DEFLECTION TEST SETUP

FIGURE 8

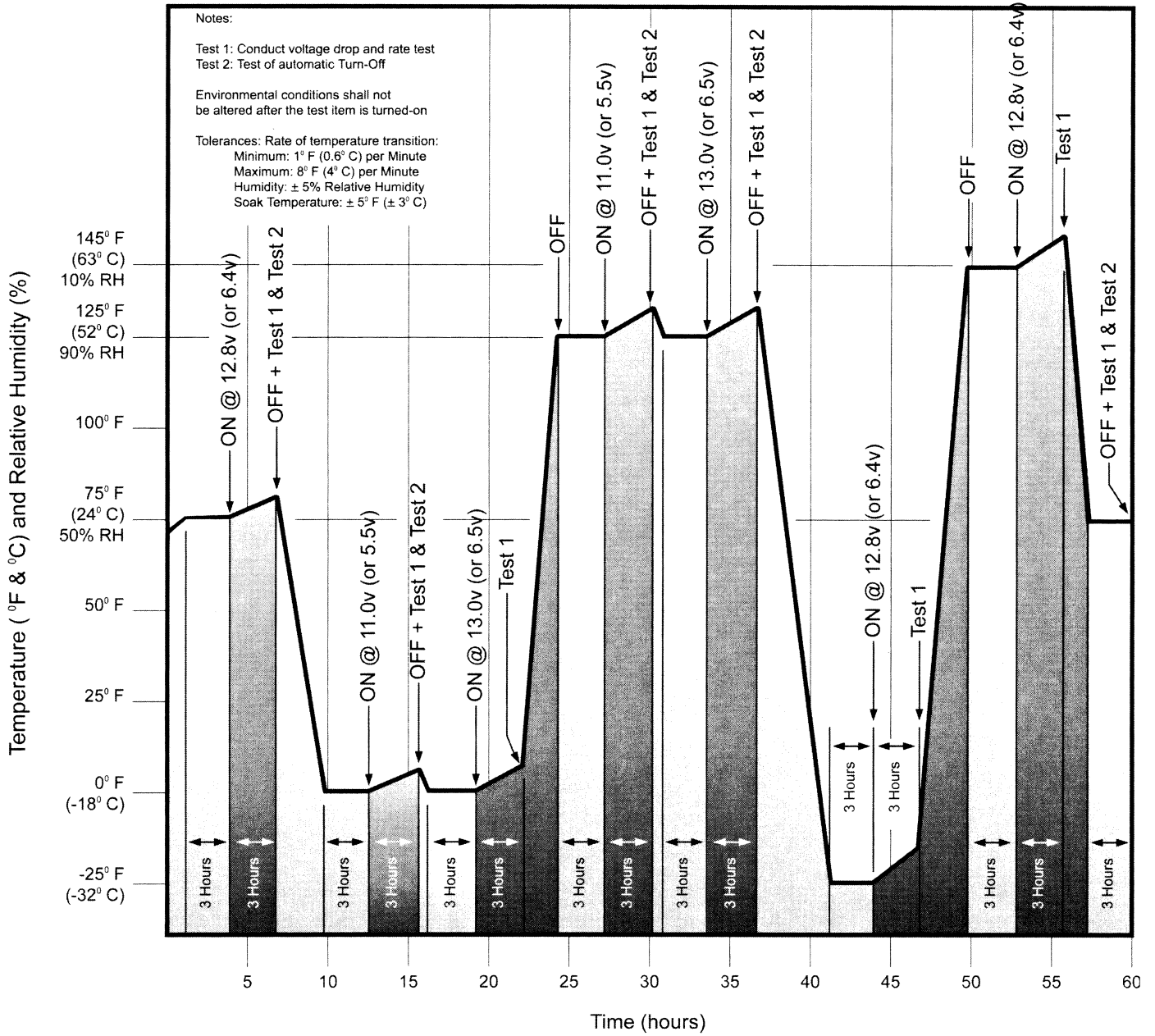

ENVIRONMENTAL TEST PROFILE

FIGURE 9

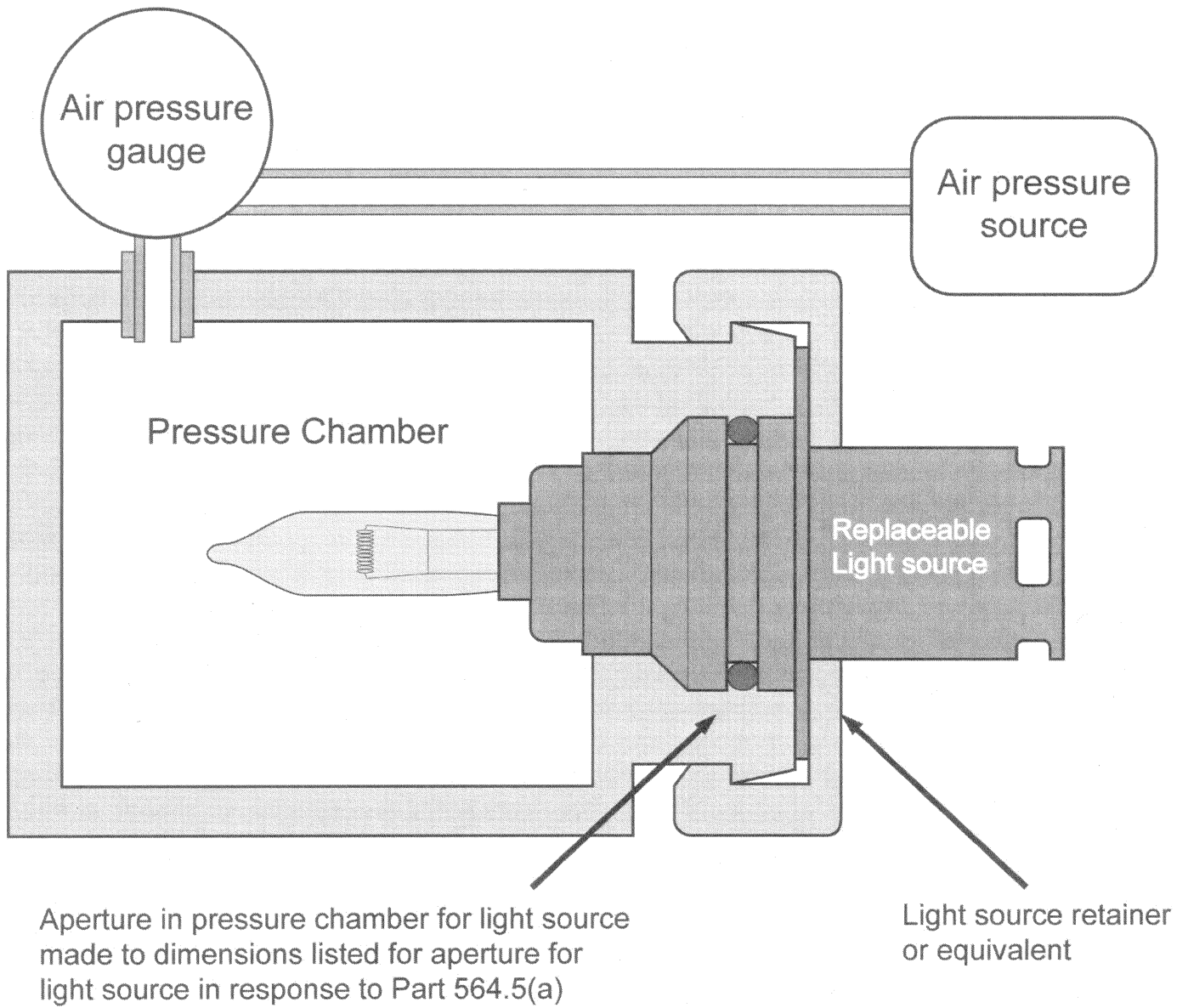

REPLACEABLE LIGHT SOURCE PRESSURE TEST SETUP

FIGURE 10

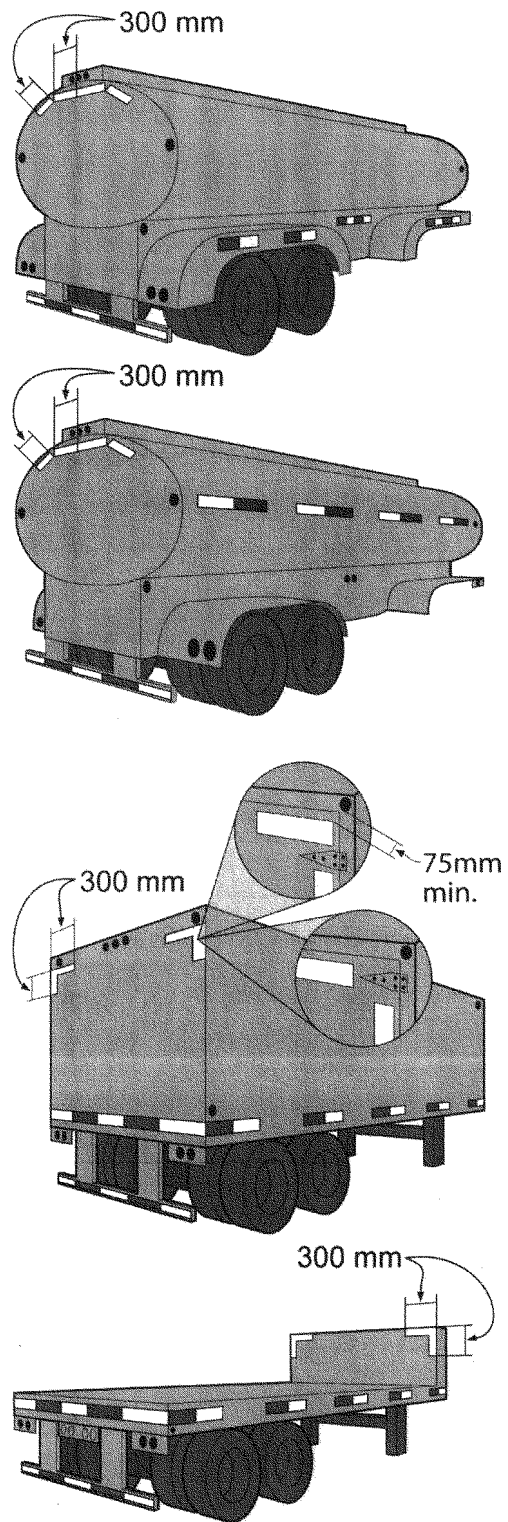

Trailer Conspicuity
Treatment Examples

FIGURE 11



Grade DOT-C2 = 300 mm (±150 mm) L x 50 mm W Minimum
 Grade DOT-C3 = 300 mm (±150 mm) L x 75 mm W Minimum
 Grade DOT-C4 = 300 mm (±150 mm) L x 100 mm W Minimum

$$X + X + \dots < 2/3 L \text{ and } Y + Y + \dots < 2/3 L$$

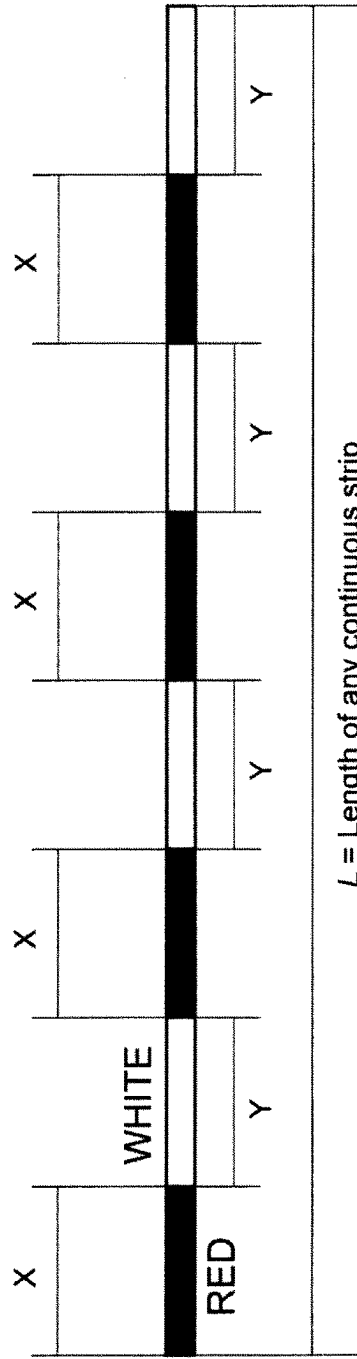

TRAILER CONSPICUITY DETAIL I

FIGURE 12-1

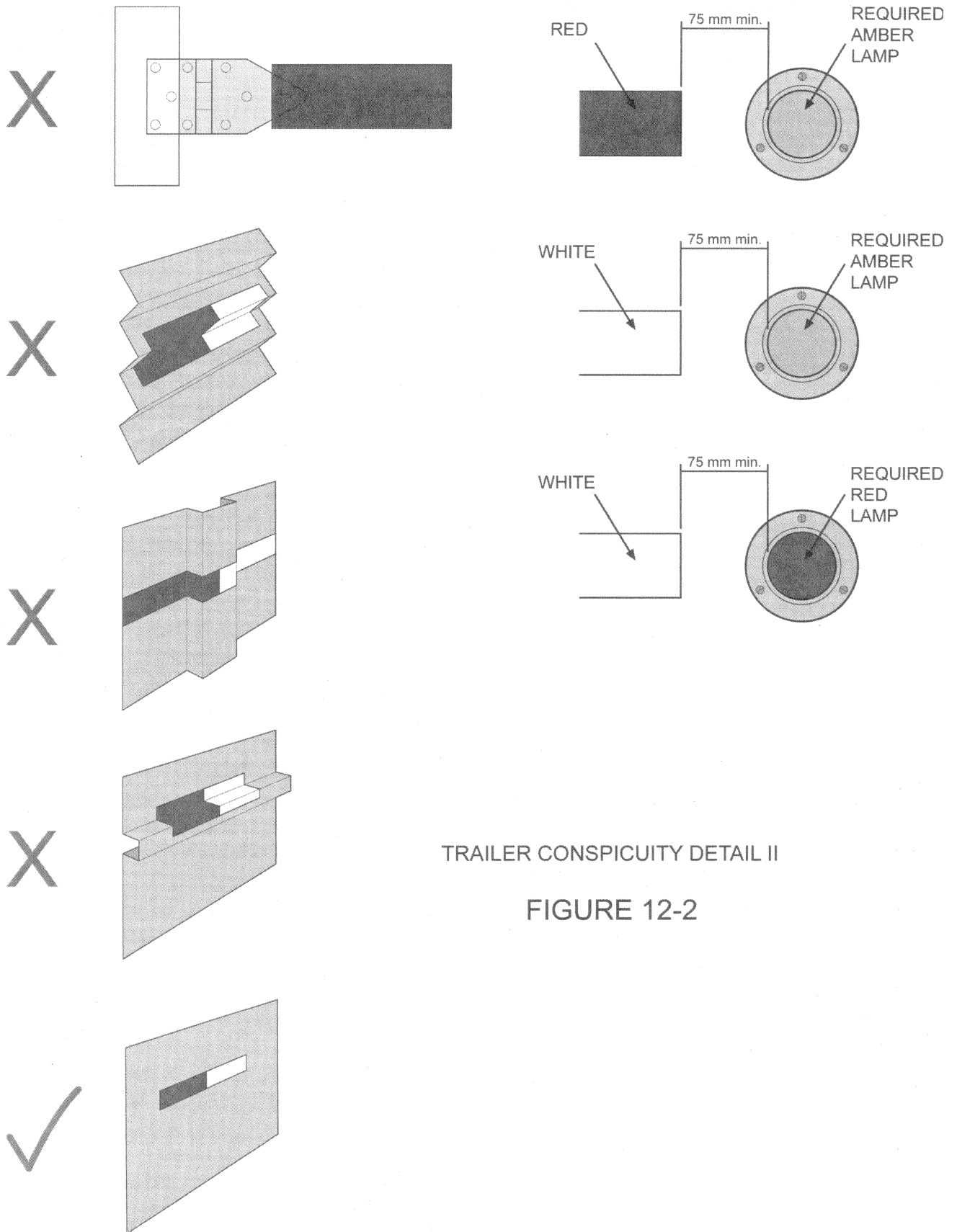

TRAILER CONSPICUITY DETAIL II

FIGURE 12-2

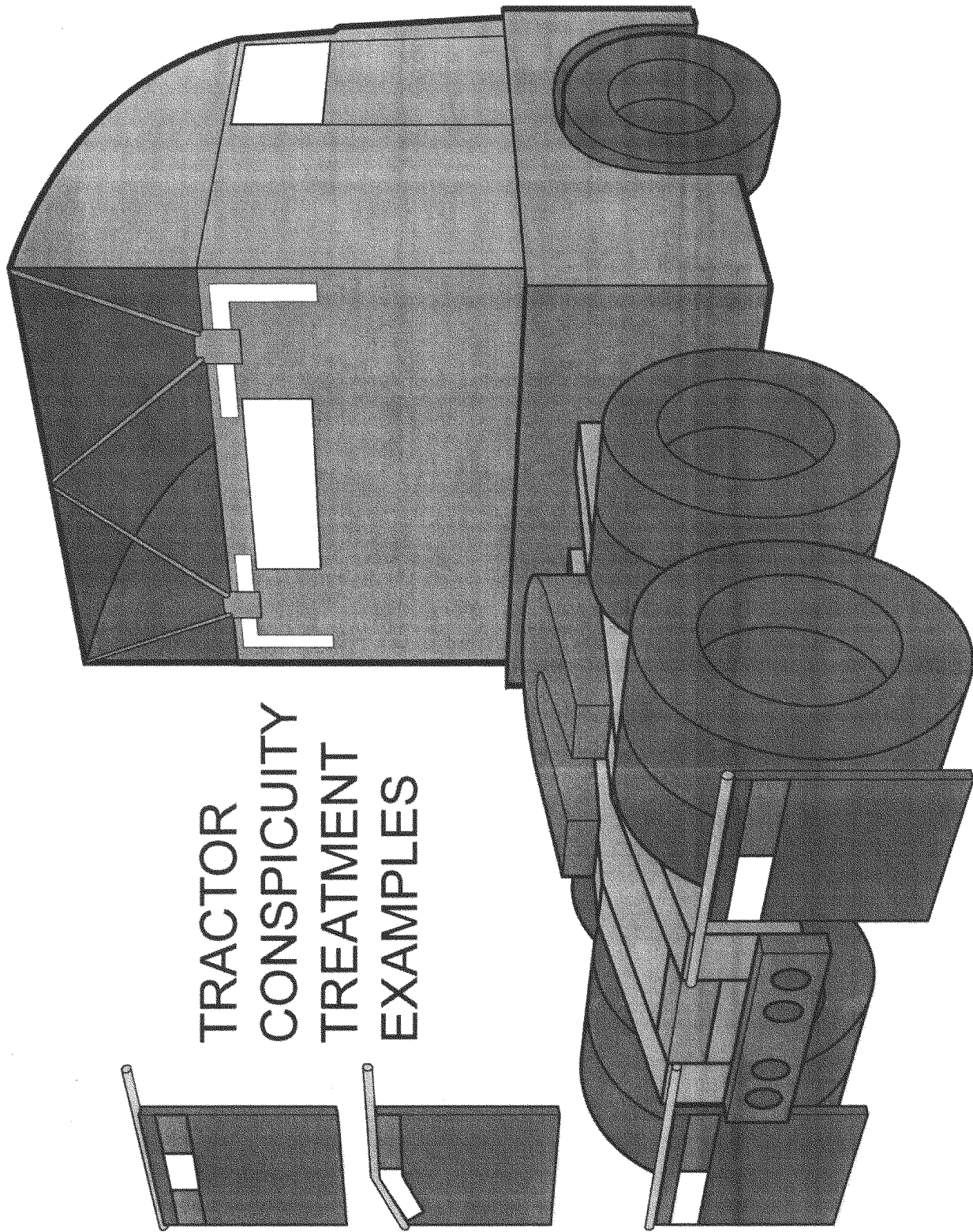

TRACTOR
CONSPICUITY
TREATMENT
EXAMPLES

FIGURE 13

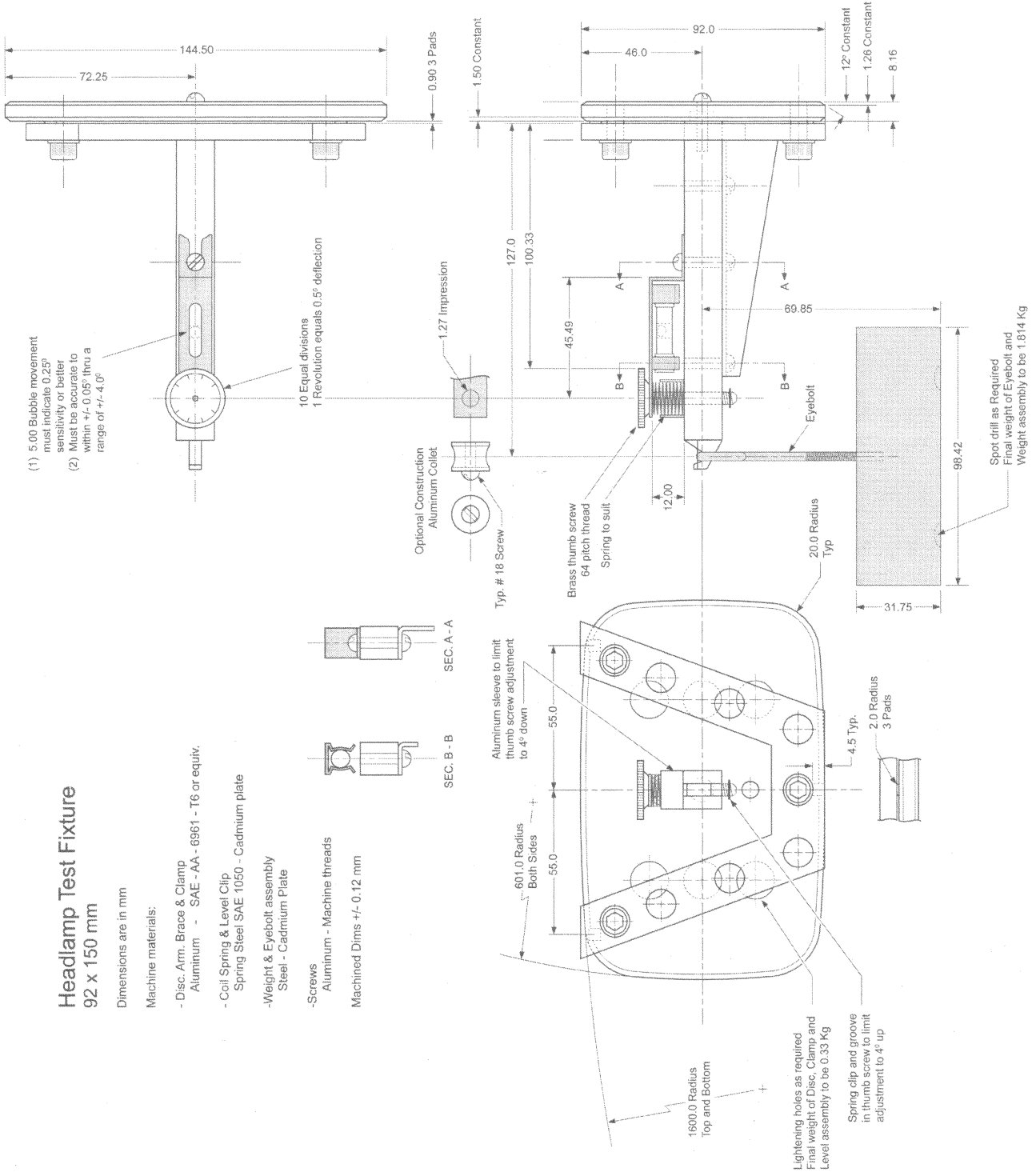

92 x 150 mm HEADLAMP AIM DEFLECTION TEST SETUP

FIGURE 14

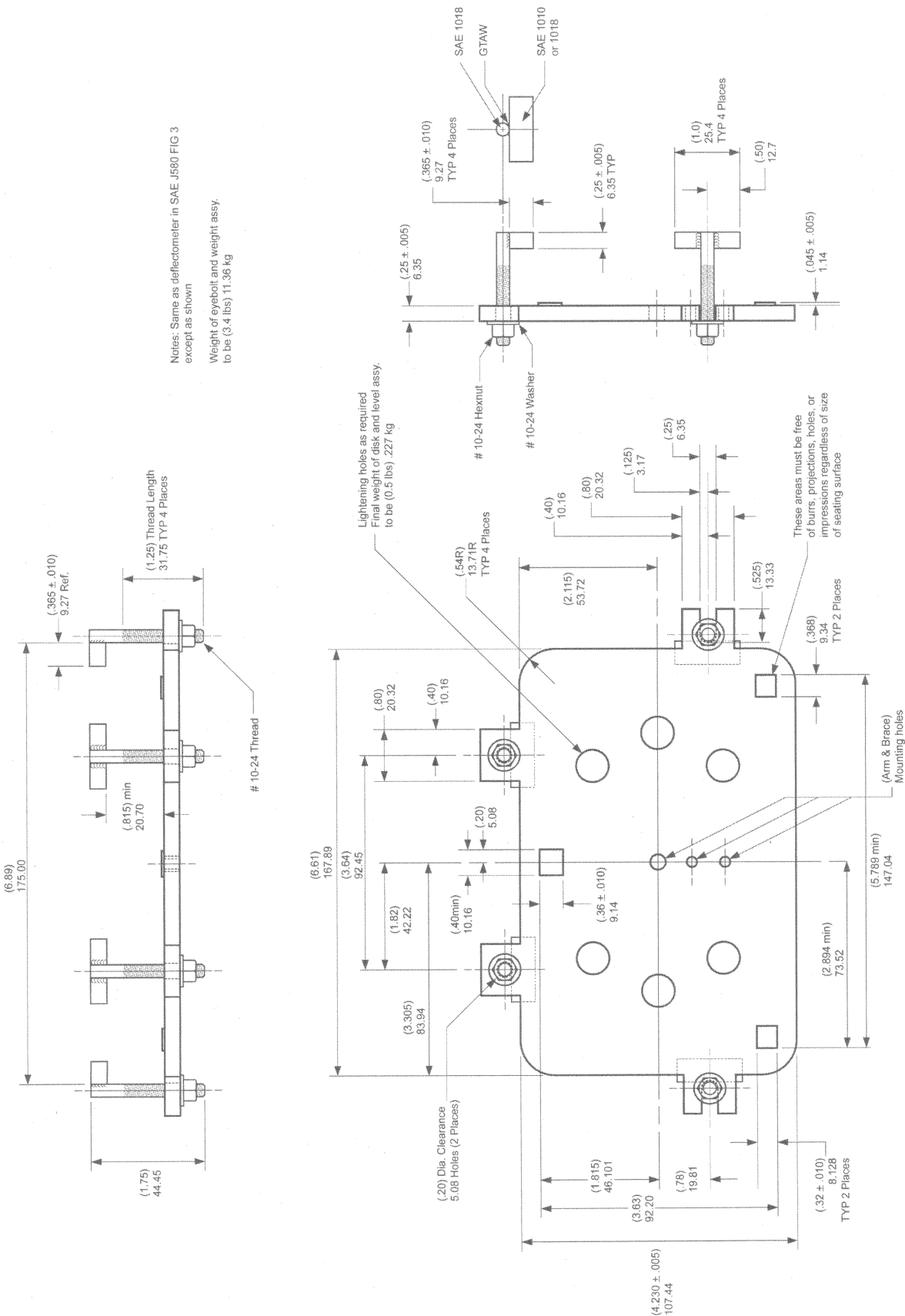

TYPES G AND H HEADLAMP AIM DEFLECTION TEST SETUP

FIGURE 15

**SAE HEADLAMP TEST FIXTURE
100 X 165 MM**

DIMENSIONS ARE IN mm

MACHINE MATERIALS:

DISC, ARM AND BRACE-ALUMINUM-SAE-AA-6061-T6 OR EQUIV
COIL SPRING AND LEVEL CLIP-SPRING STEEL
SAE 1050-CADMIUM PLATE

WEIGHT AND EYE BOLT ASSEMBLY-STEEL-CADMIUM PLATE
SCREWS-ALUMINUM-MACHINE THREADS
MACHINED DIM ± 0.13 mm

SAE 100 X 165 mm - HEADLAMP TEST FIXTURE

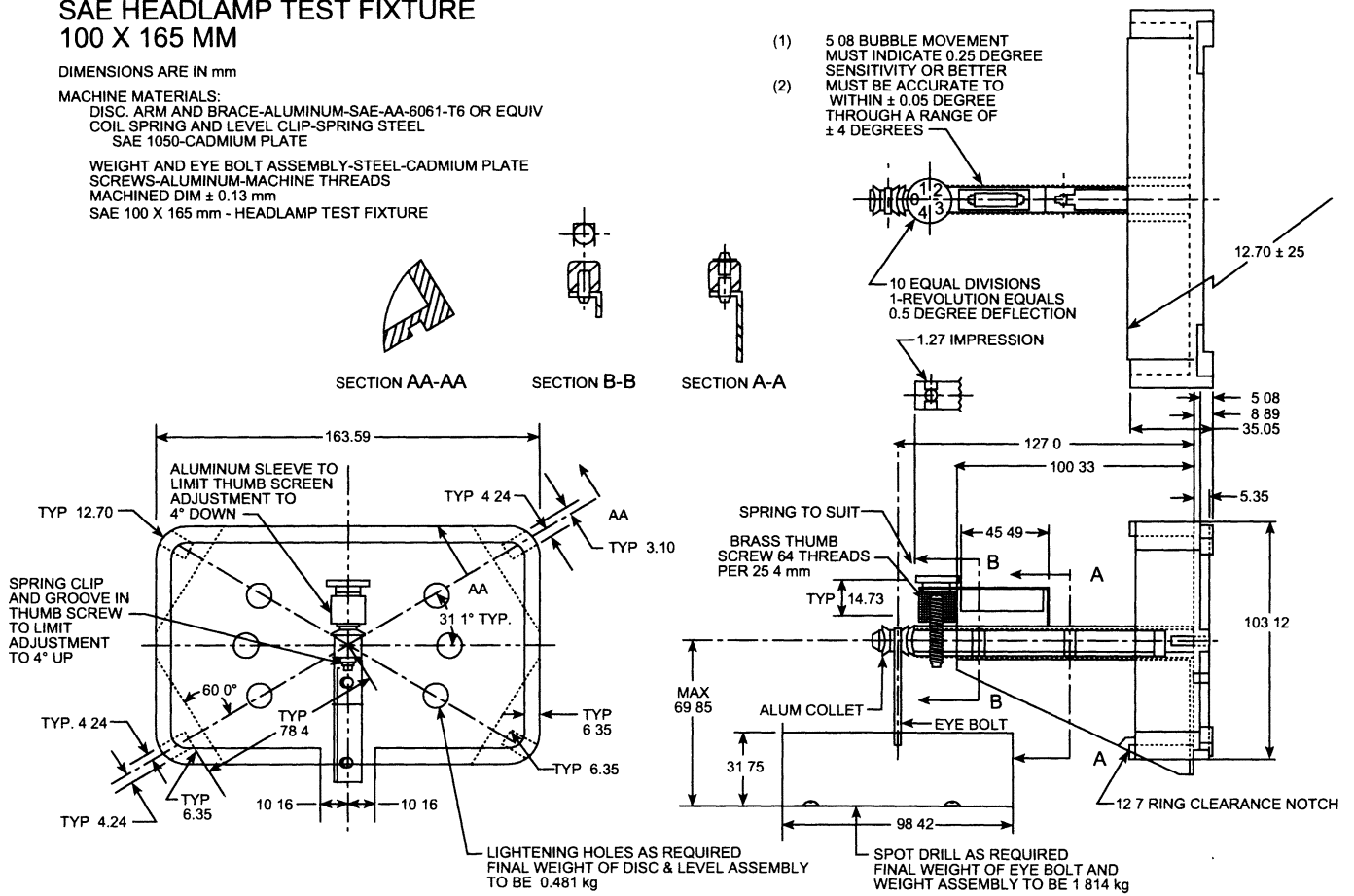

TYPES A AND E HEADLAMP AIM DEFLECTION TEST SETUP

FIGURE 16

**SAE HEADLAMP TEST FIXTURE
142 X 200 MM**

DIMENSIONS ARE IN mm

MACHINE MATERIALS:
DISC, ARM AND BRACE-ALUMINUM-SAE-AA-6061-T6 OR EQUIV
COIL SPRING AND LEVEL CLIP-SPRING STEEL
SAE 1050-CADMIUM PLATE

WEIGHT AND EYE BOLT ASSEMBLY-STEEL-CADMIUM PLATE
SCREWS-ALUMINUM-MACHINE THREADS
MACHINED DIM ± 0.13 mm
SAE 142 X 200 mm - HEADLAMP TEST FIXTURE

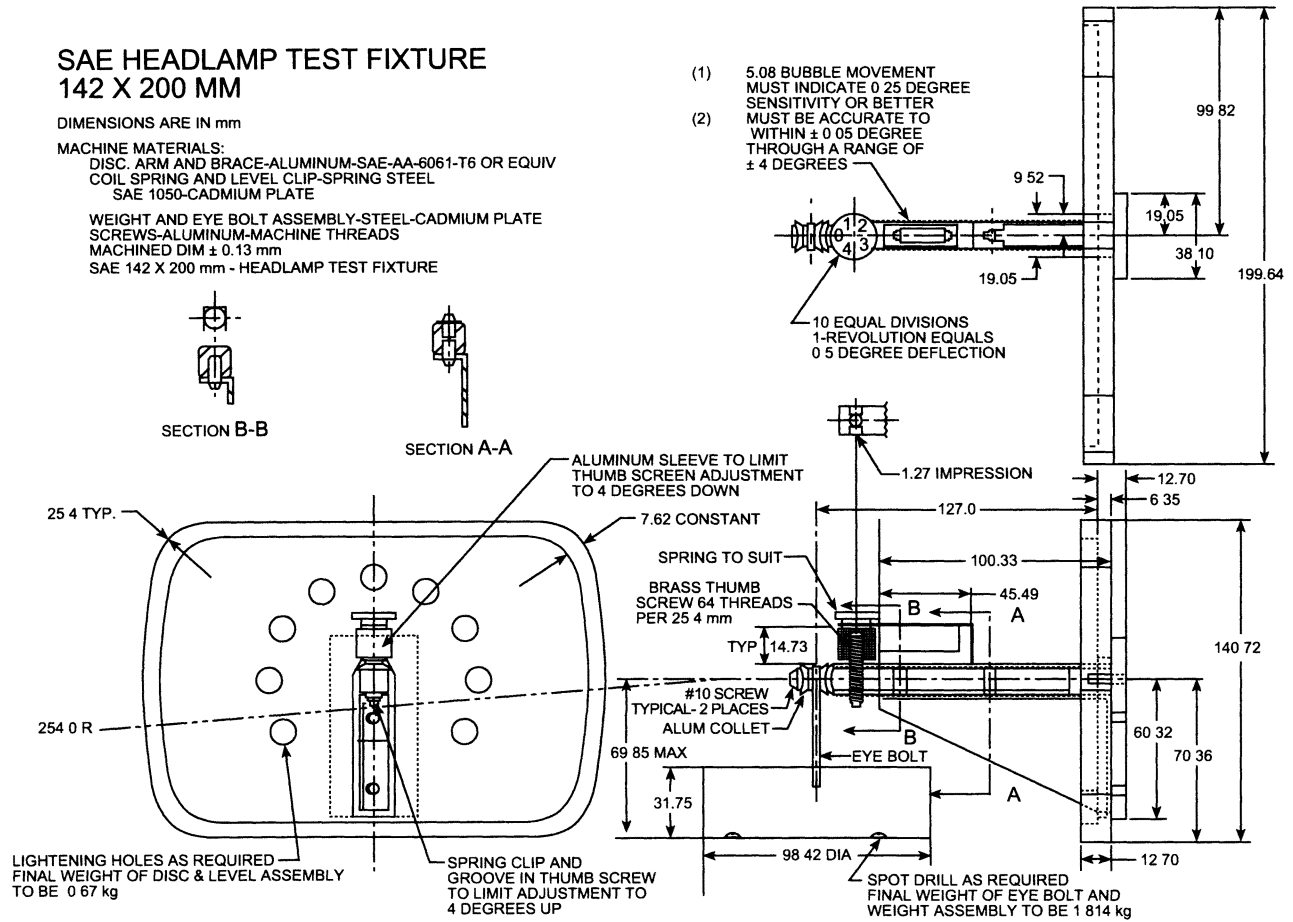

TYPE B HEADLAMP AIM DEFLECTION TEST SETUP

FIGURE 17

UNIT	A DIM	B DIM
SAE 5.75	144.53	134.62
SAE 7.00	178.31	168.66

- (1) 5.08 BUBBLE MOVEMENT MUST INDICATE 0.25 DEGREE SENSITIVITY OR BETTER
- (2) COIL SPRING AND LEVEL CLIP-SPRING STEEL MUST BE ACCURATE TO WITHIN ± 0.05 DEGREE THROUGH A RANGE OF ± 4 DEGREES

DIMENSIONS ARE IN mm

MACHINE MATERIALS.

DISC, ARM AND BRACE-ALUMINUM-SAE-AA-6061-T6 OR EQUIV
 COIL SPRING AND LEVEL CLIP-SPRING STEEL
 SAE 1050-CADMIUM PLATE

WEIGHT AND EYE BOLT ASSEMBLY-STEEL-CADMIUM PLATE
 SCREWS-ALUMINUM-MACHINE THREADS
 MACHINED DIM ± 0.13 mm
 SAE 146 AND SAE 178 - HEADLAMP TEST FIXTURE

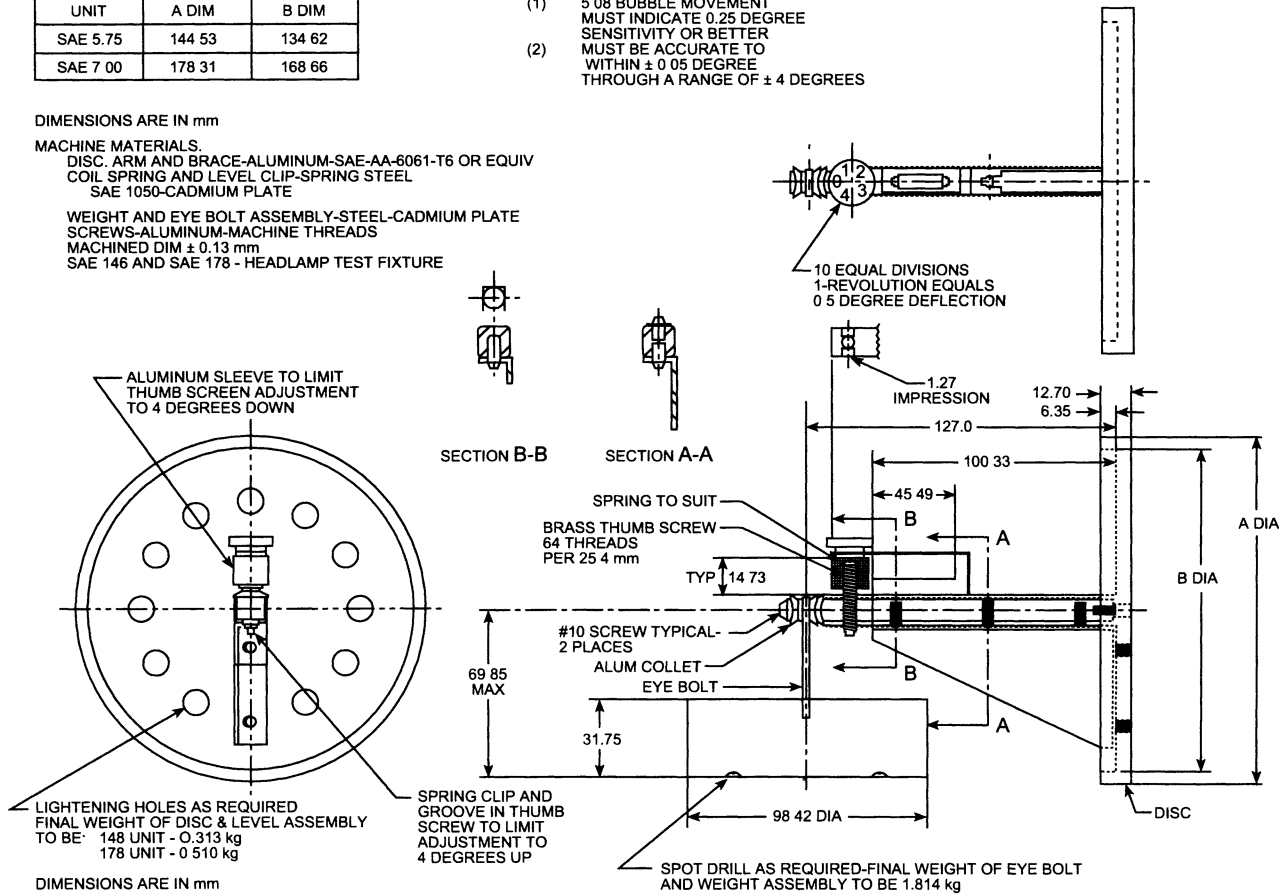

TYPES C AND D HEADLAMP AIM DEFLECTION TEST SETUP

FIGURE 18

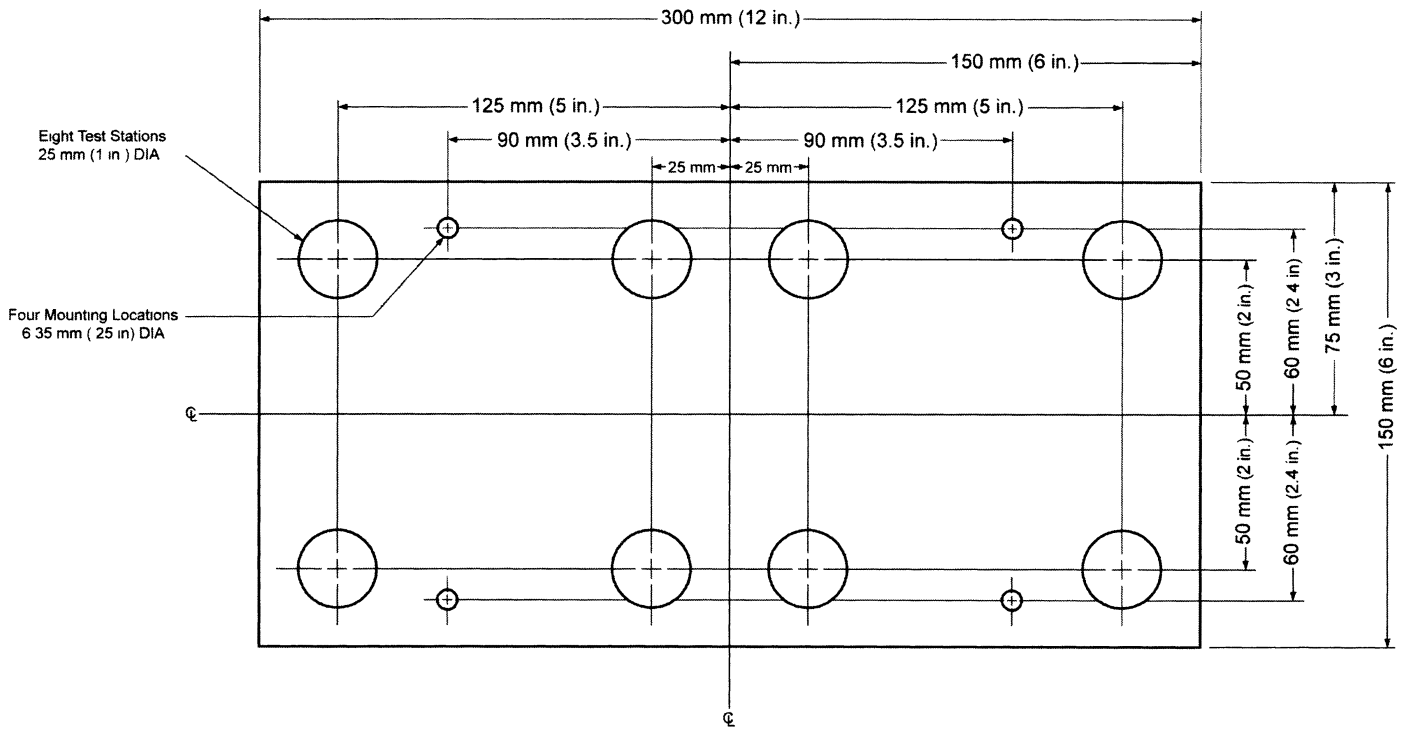

Test Plate for Vehicles other than Motorcycles and Motor Driven Cycles

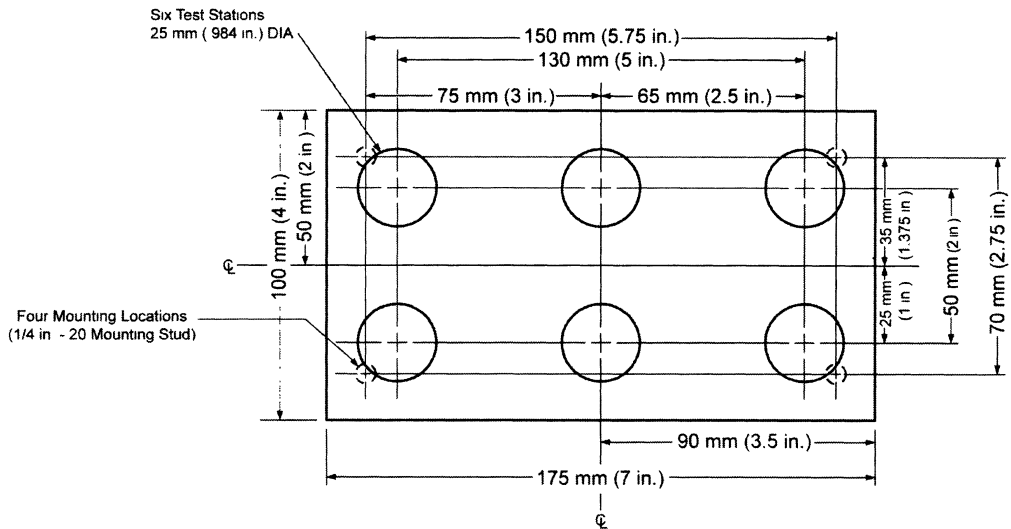

Test Plate for Motorcycles and Motor Driven Cycles

LICENSE PLATE LAMP TARGET LOCATIONS

FIGURE 19

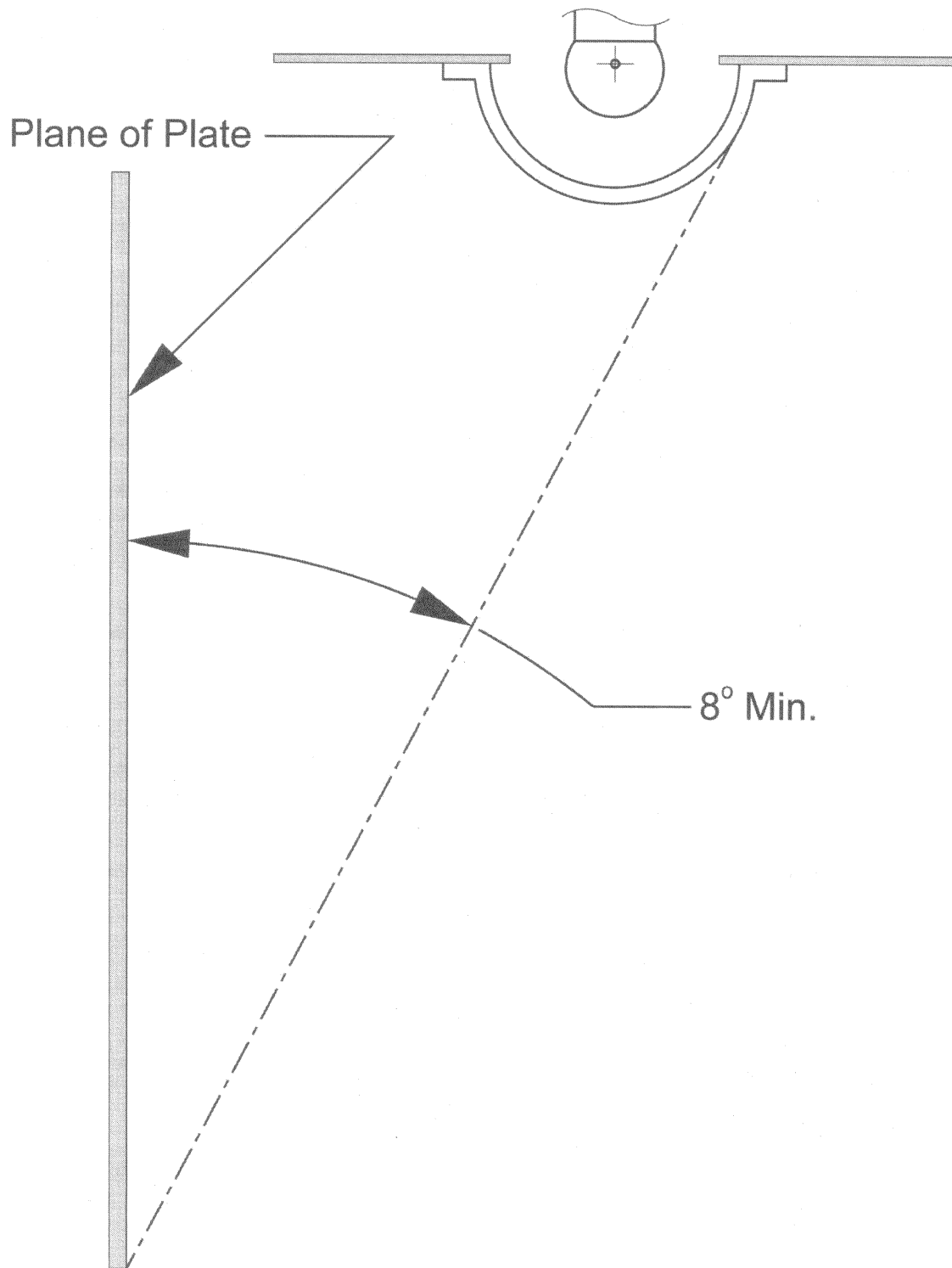

License Plate Lamp Measurement of Incident Light Angle

FIGURE 20

CAM PROFILE RADII*

Point	Radius, in.	Point	Radius, in.	Point	Radius, in.	Point	Radius, in.
1	0.5000	6	0.5504	11	0.6284	16	0.7064
2	0.5000	7	0.5660	12	0.6440	17	0.7220
3	0.5086	8	0.5816	13	0.6596	18	0.7376
4	0.5192	9	0.5972	14	0.6752	19	0.7466
5	0.5348	10	0.6128	15	0.6908	20	0.7500

* The cam width is between 1/2 and 1 in.

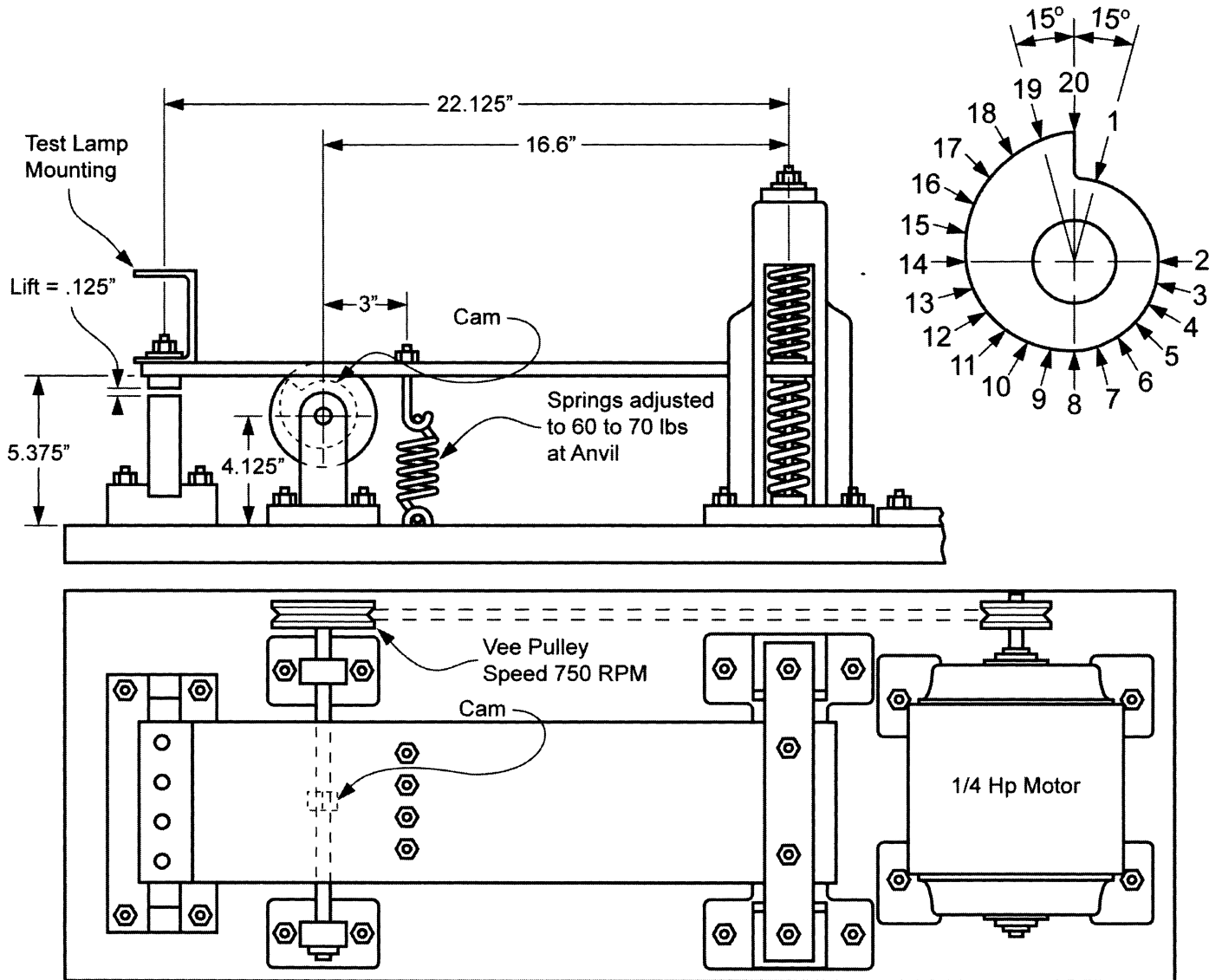
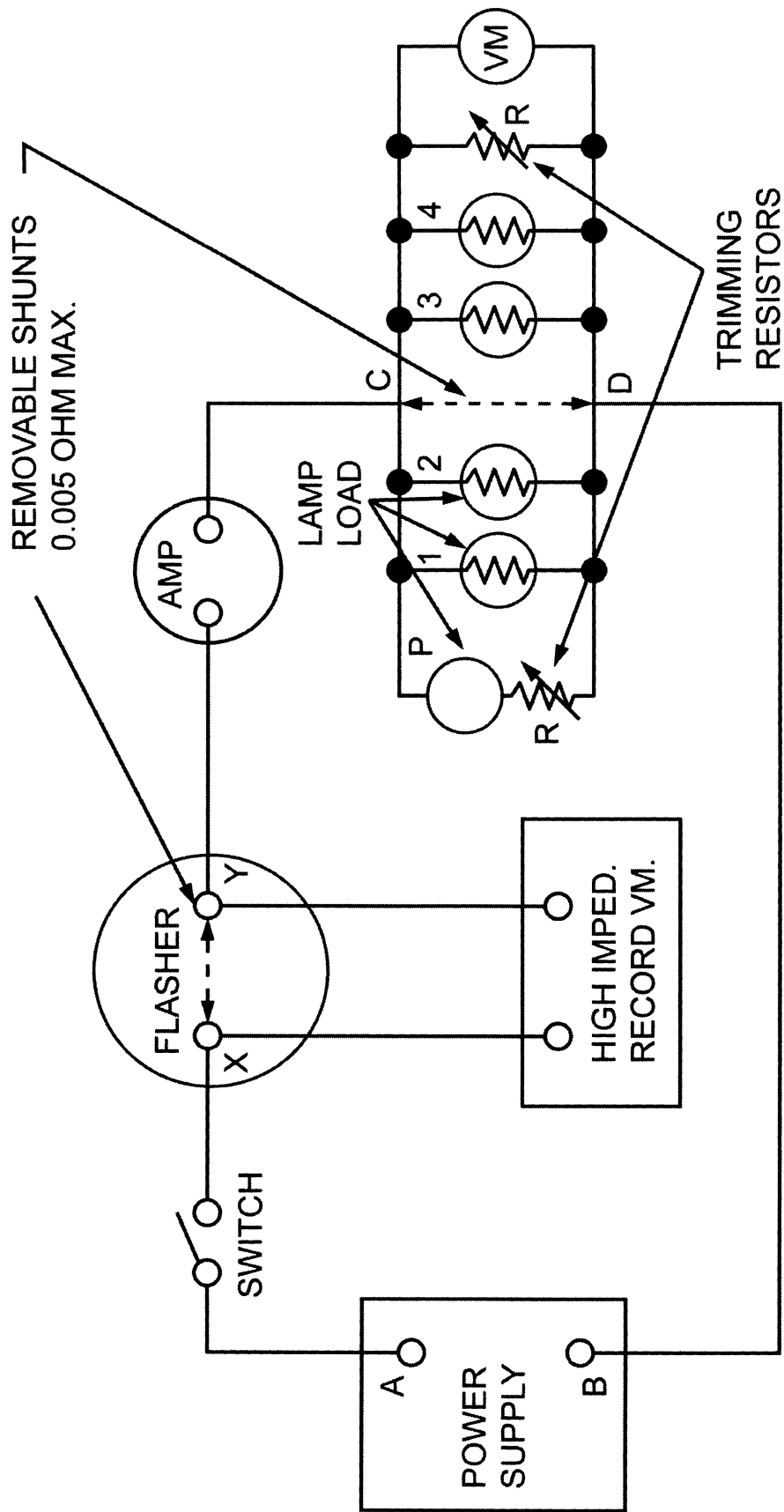

FIGURE 21 VIBRATION TEST MACHINE



FLASHER STANDARD TEST CIRCUIT
FIGURE 22

Appendix to § 571.108: Table of Contents

Sec.			
571.108	Standard No. 108; Lamps, reflective devices, and associated equipment.	S7.1.1.7	Visibility.
S1	Scope.	S7.1.1.8	Indicator.
S2	Purpose.	S7.1.1.9	Markings.
S3	Application.	S7.1.1.10	Spacing to other lamps.
S4	Definitions.	S7.1.1.10.2	Spacing measurement for non-reflector lamps.
S5	References to SAE publications.	S7.1.1.10.3	Spacing measurement for lamps with reflectors.
S5.2	Incorporation by reference.	S7.1.1.10.4	Spacing based photometric multipliers.
S6	Vehicle requirements.	S7.1.1.11	Multiple compartments and multiple lamps.
S6.1	Required lamps, reflective devices, and associated equipment by vehicle type.	S7.1.1.11.4	Lamps installed on vehicles 2032 mm or more in overall width.
S6.1.1	Quantity.	S7.1.1.12	Ratio to parking lamps and clearance lamps.
S6.1.1.1	Conspicuity systems.	S7.1.1.13	Photometry.
S6.1.1.2	High-mounted stop lamps.	S7.1.1.14	Physical tests.
S6.1.1.3	Truck tractor rear turn signal lamps.	S7.1.2	Rear turn signal lamps.
S6.1.1.4	Daytime running lamps.	S7.1.2.1	Number.
S6.1.2	Color.	S7.1.2.2	Color of light.
S6.1.3	Mounting location.	S7.1.2.3	Mounting location.
S6.1.3.3	License plate lamp.	S7.1.2.4	Mounting height.
S6.1.3.4	High-mounted stop lamp.	S7.1.2.5	Activation.
S6.1.3.4.1	Interior mounting.	S7.1.2.6	Effective projected luminous lens area.
S6.1.3.4.2	Accessibility.	S7.1.2.7	Visibility.
S6.1.3.5	Headlamp beam mounting.	S7.1.2.8	Indicator.
S6.1.3.5.1	Vertical headlamp arrangement.	S7.1.2.9	Markings.
S6.1.3.5.2	Horizontal headlamp arrangement.	S7.1.2.10	Spacing to other lamps.
S6.1.3.6	Auxiliary lamps mounted near identification lamps.	S7.1.2.11	Multiple compartments and multiple lamps.
S6.1.4	Mounting height.	S7.1.2.11.4	Lamps installed on vehicles 2032 mm or more in overall width.
S6.1.4.1	High-mounted stop lamps.	S7.1.2.12	Ratio to taillamps and clearance lamps.
S6.1.5	Activation.	S7.1.2.13	Photometry.
S6.1.5.1	Hazard warning signal.	S7.1.2.14	Physical tests.
S6.1.5.2	Simultaneous beam activation.	S7.1.3	Combined lamp bulb indexing.
S6.2	Impairment.	S7.2	Taillamps.
S6.2.3	Headlamp obstructions.	S7.2.1	Number.
S6.3	Equipment combinations.	S7.2.2	Color of light.
S6.4	Lens area, visibility and school bus signal lamp aiming.	S7.2.3	Mounting location.
S6.4.1	Effective projected luminous lens area requirements.	S7.2.4	Mounting height.
S6.4.2	Visibility.	S7.2.5	Activation.
S6.4.3	Visibility options.	S7.2.6	Effective projected luminous lens area.
S6.4.3(a)	Lens area option.	S7.2.7	Visibility.
S6.4.3(b)	Luminous intensity option.	S7.2.8	Indicator.
S6.4.4	Legacy visibility alternative.	S7.2.9	Markings.
S6.4.5	School bus signal lamp aiming.	S7.2.10	Spacing to other lamps.
S6.5	Marking.	S7.2.11	Multiple compartments and multiple lamps.
S6.5.1	DOT marking.	S7.2.11.4	Taillamps installed on vehicles 2032 mm or more in overall width.
S6.5.2	DRL marking.	S7.2.12	Ratio.
S6.5.3	Headlamp markings.	S7.2.13	Photometry.
S6.5.3.1	Trademark.	S7.2.14	Physical tests.
S6.5.3.2	Voltage and trade number.	S7.3	Stop lamps.
S6.5.3.3	Sealed beam headlamp markings.	S7.3.1	Number.
S6.5.3.4	Replaceable bulb headlamp markings.	S7.3.2	Color of light.
S6.5.3.5	Additional headlamp markings.	S7.3.3	Mounting location.
S6.6	Associated equipment.	S7.3.4	Mounting height.
S6.6.3	License plate holder.	S7.3.5	Activation.
S6.7	Replacement equipment.	S7.3.6	Effective projected luminous lens area.
S6.7.1	General.	S7.3.7	Visibility.
S6.7.2	Version of this standard.	S7.3.8	Indicator.
S7	Signal lamp requirements.	S7.3.9	Markings.
S7.1	Turn signal lamps.	S7.3.10	Spacing to other lamps.
S7.1.1	Front turn signal lamps.	S7.3.11	Multiple compartments and multiple lamps.
S7.1.1.1	Number.	S7.3.11.4	Lamps installed on vehicles 2032 mm or more in overall width.
S7.1.1.2	Color of light.	S7.3.12	Ratio to taillamps.
S7.1.1.3	Mounting location.	S7.3.13	Photometry.
S7.1.1.4	Mounting height.		
S7.1.1.5	Activation.		
S7.1.1.6	Effective projected luminous lens area.		
		S7.3.14	Physical tests.
		S7.3.15	Combined lamp bulb indexing.
		S7.4	Side marker lamps.
		S7.4.1	Number.
		S7.4.2	Color of light.
		S7.4.3	Mounting location.
		S7.4.4	Mounting height.
		S7.4.5	Activation.
		S7.4.6	Effective projected luminous lens area.
		S7.4.7	Visibility.
		S7.4.8	Indicator.
		S7.4.9	Markings.
		S7.4.10	Spacing to other lamps.
		S7.4.11	Multiple compartments and multiple lamps.
		S7.4.12	Ratio.
		S7.4.13	Photometry.
		S7.4.13.2	Inboard photometry.
		S7.4.14	Physical tests.
		S7.5	Clearance and identification lamps.
		S7.5.1	Number.
		S7.5.2	Color of light.
		S7.5.3	Mounting location.
		S7.5.4	Mounting height.
		S7.5.5	Activation.
		S7.5.6	Effective projected luminous lens area.
		S7.5.7	Visibility.
		S7.5.8	Indicator.
		S7.5.9	Markings.
		S7.5.10	Spacing to other lamps.
		S7.5.11	Multiple compartments and multiple lamps.
		S7.5.12	Ratio.
		S7.5.12.1	Clearance lamps.
		S7.5.12.2	Identification lamps.
		S7.5.13	Photometry.
		S7.5.14	Physical tests.
		S7.6	Backup lamps.
		S7.6.1	Number.
		S7.6.2	Color of light.
		S7.6.3	Mounting location.
		S7.6.4	Mounting height.
		S7.6.5	Activation.
		S7.6.6	Effective projected luminous lens area.
		S7.6.7	Visibility.
		S7.6.8	Indicator.
		S7.6.9	Markings.
		S7.6.10	Spacing to other lamps.
		S7.6.11	Multiple compartments and multiple lamps.
		S7.6.12	Ratio.
		S7.6.13	Photometry.
		S7.6.14	Physical tests.
		S7.7	License plate lamps.
		S7.7.1	Number.
		S7.7.2	Color of light.
		S7.7.3	Mounting location.
		S7.7.4	Mounting height.
		S7.7.5	Activation.
		S7.7.6	Effective projected luminous lens area.
		S7.7.7	Visibility.
		S7.7.8	Indicator.
		S7.7.9	Markings.
		S7.7.10	Spacing to other lamps.
		S7.7.11	Multiple compartments and multiple lamps.
		S7.7.12	Ratio.
		S7.7.13	Photometry.
		S7.7.14	Physical tests.
		S7.7.15	Installation.
		S7.7.15.4	Incident light from single lamp.
		S7.7.15.5	Incident light from multiple lamps.

- S7.8 *Parking lamps.*
- S7.8.1 *Number.*
- S7.8.2 *Color of light.*
- S7.8.3 *Mounting location.*
- S7.8.4 *Mounting height.*
- S7.8.5 *Activation.*
- S7.8.6 *Effective projected luminous lens area.*
- S7.8.7 *Visibility.*
- S7.8.8 *Indicator.*
- S7.8.9 *Markings.*
- S7.8.10 *Spacing to other lamps.*
- S7.8.11 *Multiple compartments and multiple lamps.*
- S7.8.12 *Ratio.*
- S7.8.13 *Photometry.*
- S7.8.14 *Physical tests.*
- S7.9 *High-mounted stop lamps.*
- S7.9.1 *Number.*
- S7.9.2 *Color of light.*
- S7.9.3 *Mounting location.*
- S7.9.4 *Mounting height.*
- S7.9.5 *Activation.*
- S7.9.6 *Effective projected luminous lens area.*
- S7.9.7 *Visibility.*
- S7.9.8 *Indicator.*
- S7.9.9 *Markings.*
- S7.9.10 *Spacing to other lamps.*
- S7.9.11 *Multiple compartments and multiple lamps.*
- S7.9.12 *Ratio.*
- S7.9.13 *Photometry.*
- S7.9.14 *Physical tests.*
- S7.10 *Daytime running lamps (DRLs).*
- S7.10.1 *Number.*
- S7.10.2 *Color of light.*
- S7.10.3 *Mounting location.*
- S7.10.4 *Mounting height.*
- S7.10.5 *Activation.*
- S7.10.6 *Effective projected luminous lens area.*
- S7.10.7 *Visibility.*
- S7.10.8 *Indicator.*
- S7.10.9 *Markings.*
- S7.10.10 *Spacing to other lamps.*
- S7.10.10.1 *Spacing to turn signal lamps.*
- S7.10.11 *Multiple compartments and multiple lamps.*
- S7.10.12 *Ratio.*
- S7.10.13 *Photometry.*
- S7.10.14 *Physical tests.*
- S7.11 *School bus signal lamps.*
- S7.11.1 *Number.*
- S7.11.2 *Color of light.*
- S7.11.3 *Mounting location.*
- S7.11.4 *Mounting height.*
- S7.11.5 *Activation.*
- S7.11.6 *Effective projected luminous lens area.*
- S7.11.7 *Visibility.*
- S7.11.8 *Indicator.*
- S7.11.9 *Markings.*
- S7.11.10 *Spacing to other lamps.*
- S7.11.11 *Multiple compartments and multiple lamps.*
- S7.11.12 *Ratio.*
- S7.11.13 *Photometry.*
- S7.11.14 *Physical tests.*
- S8 *Reflective device requirements.*
- S8.1 *Reflex reflectors.*
- S8.1.1 *Number.*
- S8.1.2 *Color.*
- S8.1.3 *Mounting location.*
- S8.1.4 *Mounting height.*
- S8.1.5 *Activation.*
- S8.1.6 *Effective projected luminous lens area.*
- S8.1.7 *Visibility.*
- S8.1.8 *Indicator.*
- S8.1.9 *Markings.*
- S8.1.10 *Spacing to other lamps or reflective devices.*
- S8.1.11 *Photometry.*
- S8.1.12 *Physical tests.*
- S8.1.13 *Alternative side reflex reflector material.*
- S8.2 *Conspicuity systems.*
- S8.2.1 *Retroreflective sheeting.*
- S8.2.1.2 *Retroreflective sheeting material.*
- S8.2.1.3 *Certification marking.*
- S8.2.1.4 *Application pattern.*
- S8.2.1.4.1 *Alternating red and white materials.*
- S8.2.1.5 *Application location.*
- S8.2.1.6 *Application spacing.*
- S8.2.1.7 *Photometry.*
- S8.2.2 *Conspicuity reflex reflectors.*
- S8.2.2.1 *Certification marking.*
- S8.2.2.2 *Application pattern.*
- S8.2.2.2.1 *Alternating red and white materials.*
- S8.2.2.2.2 *White material.*
- S8.2.2.3 *Photometry.*
- S8.2.3 *Conspicuity system installation on trailers.*
- S8.2.3.1 *Trailer rear.*
- S8.2.3.1.1 *Element 1-alternating red and white materials.*
- S8.2.3.1.2 *Element 2-white.*
- S8.2.3.1.3 *Element 3-alternating red and white materials.*
- S8.2.3.2 *Trailer side-alternating red and white materials.*
- S8.2.4 *Conspicuity system installation on truck tractors.*
- S8.2.4.1 *Element 1-alternating red and white materials.*
- S8.2.4.2 *Element 2-white.*
- S9 *Associated equipment requirements.*
- S9.1 *Turn signal operating unit.*
- S9.1.2 *Physical tests.*
- S9.2 *Turn signal flasher.*
- S9.2.2 *Physical tests.*
- S9.3 *Turn signal pilot indicator.*
- S9.3.4 *Indicator size and color.*
- S9.3.6 *Turn signal lamp failure.*
- S9.4 *Headlamp beam switching device.*
- S9.4.1 *Semi-automatic headlamp beam switching device.*
- S9.4.1.1 *Operating instructions.*
- S9.4.1.2 *Manual override.*
- S9.4.1.3 *Fail safe operation.*
- S9.4.1.4 *Automatic dimming indicator.*
- S9.4.1.5 *Lens accessibility.*
- S9.4.1.6 *Mounting height.*
- S9.4.1.7 *Physical tests.*
- S9.5 *Upper beam headlamp indicator.*
- S9.5.1 *Indicator size and location.*
- S9.6 *Vehicular hazard warning signal operating unit.*
- S9.6.2 *Operating unit switch.*
- S9.6.3 *Physical tests.*
- S9.7 *Vehicular hazard warning signal flasher.*
- S9.7.2 *Physical tests.*
- S9.8 *Vehicular hazard warning signal pilot indicator.*
- S9.8.4 *Indicator size and color.*
- S10 *Headlighting system requirements.*
- S10.1 *Vehicle headlighting systems.*
- S10.2 *Aiming.*
- S10.3 *Number.*
- S10.4 *Color of light.*
- S10.5 *Mounting location.*
- S10.6 *Mounting height.*
- S10.7 *Activation.*
- S10.8 *Effective projected luminous lens area.*
- S10.9 *Visibility.*
- S10.10 *Indicator.*
- S10.11 *Markings.*
- S10.12 *Spacing to other lamps.*
- S10.13 *Sealed beam headlighting systems.*
- S10.13.1 *Installation.*
- S10.13.2 *Simultaneous aim.*
- S10.13.3 *Photometry.*
- S10.13.4 *Physical tests.*
- S10.14 *Integral beam headlighting systems.*
- S10.14.1 *Installation.*
- S10.14.2 *Aimability.*
- S10.14.3 *Simultaneous aim.*
- S10.14.4 *Markings.*
- S10.14.5 *Additional light sources.*
- S10.14.6 *Photometry.*
- S10.14.7 *Physical tests.*
- S10.15 *Replaceable bulb headlighting systems.*
- S10.15.1 *Installation.*
- S10.15.2 *Aiming restrictions.*
- S10.15.3 *Replacement lens reflector units.*
- S10.15.4 *Markings.*
- S10.15.5 *Additional light sources.*
- S10.15.6 *Photometry.*
- S10.15.7 *Physical tests.*
- S10.16 *Combination headlighting systems.*
- S10.16.1 *Installation.*
- S10.16.2 *Photometry.*
- S10.16.3 *Physical tests.*
- S10.17 *Motorcycle headlighting systems.*
- S10.17.1 *Installation.*
- S10.17.1.1 *Single headlamp.*
- S10.17.1.2 *Two headlamps with both beams.*
- S10.17.1.3 *Two headlamps, upper beam and lower beam.*
- S10.17.2 *Motorcycle replaceable bulb headlamp marking.*
- S10.17.3 *Photometry.*
- S10.17.4 *Physical tests.*
- S10.17.5 *Motorcycle headlamp modulation system.*
- S10.17.5.1 *Modulation.*
- S10.17.5.2 *Replacement modulators.*
- S10.17.5.2.1 *Replacement performance.*
- S10.17.5.2.2 *Replacement instructions.*
- S10.18 *Headlamp aimability performance requirements.*
- S10.18.1 *Headlamp mounting and aiming.*
- S10.18.2 *Headlamp aiming systems.*
- S10.18.3 *Aim adjustment interaction.*
- S10.18.4 *Horizontal adjustment-visually aimed headlamp.*
- S10.18.5 *Optical axis marking.*
- S10.18.5.1 *Optical axis marking-vehicle.*
- S10.18.5.2 *Optical axis marking-lamp.*
- S10.18.5.3 *Optical axis marking-visual aim headlamp.*
- S10.18.6 *Moveable reflectors.*
- S10.18.7 *External aiming.*
- S10.18.7.1 *Headlamp aiming device locating plates.*
- S10.18.7.2 *Nonadjustable headlamp aiming device locating plates.*
- S10.18.8 *On-vehicle aiming.*
- S10.18.8.1 *Aim.*
- S10.18.8.1.1 *Vertical aim.*
- S10.18.8.1.2 *Horizontal aim.*

- S10.18.8.2 *Aiming instructions.*
- S10.18.8.3 *Permanent calibration.*
- S10.18.8.4 *Replacement units.*
- S10.18.8.5 *Physical tests.*
- S10.18.9 *Visual/optical aiming.*
- S10.18.9.1 *Vertical aim, lower beam.*
- S10.18.9.1.1 *Vertical position of the cutoff.*
- S10.18.9.1.2 *Vertical gradient.*
- S10.18.9.1.3 *Horizontal position of the cutoff.*
- S10.18.9.1.4 *Maximum inclination of the cutoff.*
- S10.18.9.1.5 *Measuring the cutoff parameter.*
- S10.18.9.2 *Horizontal aim, lower beam.*
- S10.18.9.3 *Vertical aim, upper beam.*
- S10.18.9.4 *Horizontal aim, upper beam.*
- S10.18.9.5 *Photometry.*
- S10.18.9.6 *Visual/optical identification marking.*
- S11 *Replaceable light source requirements.*
- S11.1 *Markings.*
- S11.2 *Ballast markings.*
- S11.3 *Gas discharge laboratory life.*
- S11.4 *Physical tests.*
- S12 *Headlamp concealment device requirements.*
- S12.7 *Certification election.*
- S13 *Replaceable headlamp lens requirements.*
- S14 *Physical and photometry test procedures and performance requirements.*
- S14.1 *General test procedures and performance requirements.*
- S14.1.2 *Plastic optical materials.*
- S14.1.4 *Samples.*
- S14.1.5 *Laboratory facilities.*
- S14.2 *Photometric test procedures.*
- S14.2.1 *Photometry measurements for all lamps except license lamps, headlamps, and DRLs.*
- S14.2.1.1 *Mounting.*
- S14.2.1.2 *School bus signal lamp aiming.*
- S14.2.1.3 *Measurement distance.*
- S14.2.1.4 *Location of test points.*
- S14.2.1.5 *Multiple compartment and multiple lamp photometry of turn signal lamps, stop lamps, and taillamps.*
- S14.2.1.6 *Bulbs.*
- S14.2.2 *License plate lamp photometry.*
- S14.2.2.1 *Illumination surface.*
- S14.2.2.2 *Test stations.*
- S14.2.3 *Reflex reflector and retroreflective sheeting photometry.*
- S14.2.3.1 *Mounting.*
- S14.2.3.2 *Illumination source.*
- S14.2.3.3 *Measurement distance.*
- S14.2.3.4 *Test setup.*
- S14.2.3.5 *Photodetector .*
- S14.2.3.6 *Photometry surface.*
- S14.2.3.7 *Procedure.*
- S14.2.3.8 *Measurements.*
- S14.2.3.8.1 *Reflex reflectors.*
- S14.2.3.8.2 *Retroreflective sheeting.*
- S14.2.3.8.3 *Reflex reflector photometry measurement adjustments.*
- S14.2.4 *Daytime running lamp (DRL) photometry measurements.*
- S14.2.5 *Headlamp photometry measurements.*
- S14.2.5.1 *Mounting.*
- S14.2.5.3 *Measurement distance.*
- S14.2.5.4 *Seasoning and test voltage.*
- S14.2.5.5 *Aiming.*
- S14.2.5.5.1 *Mechanically aimable headlamps using an external aimer.*
- S14.2.5.5.2 *Mechanically aimable headlamps equipped with a VHAD.*
- S14.2.5.5.3 *Visually aimable lower beam headlamps-vertical aim.*
- S14.2.5.5.4 *Visually aimable lower beam headlamps-horizontal aim.*
- S14.2.5.5.5 *Visually aimable upper beam headlamps-vertical aim.*
- S14.2.5.5.6 *Visually aimable upper beam headlamps-horizontal aim.*
- S14.2.5.5.7 *Simultaneous aim Type F sealed beam headlamps and beam contributor integral beam headlamps.*
- S14.2.5.5.8 *Motorcycle headlamp-upper beam headlamps designed to comply with Table XX.*
- S14.2.5.5.9 *Motorcycle headlamp-lower beam headlamps designed to comply with Table XX.*
- S14.2.5.6 *Positioner.*
- S14.2.5.7 *Photometer.*
- S14.2.5.7.2 *Sensor.*
- S14.2.5.8 *Location of test points.*
- S14.2.5.9 *Beam contributor photometry measurements.*
- S14.2.5.10 *Moveable reflector aimed headlamp photometry measurements.*
- S14.3 *Motorcycle headlamp out of focus test procedure and performance requirements.*
- S14.3.1 *Procedure.*
- S14.3.2 *Performance requirements.*
- S14.4 *General test procedures and performance requirements.*
- S14.4.1 *Color test.*
- S14.4.1.1 *Samples.*
- S14.4.1.2 *General procedure.*
- S14.4.1.3 *Visual method.*
- S14.4.1.3.1 *Visual method procedure.*
- S14.4.1.3.2 *Visual method performance requirements.*
- S14.4.1.3.2.1 *Red.*
- S14.4.1.3.2.2 *Yellow (Amber).*
- S14.4.1.3.2.3 *White.*
- S14.4.1.4 *Tristimulus method.*
- S14.4.1.4.1 *Tristimulus method procedure.*
- S14.4.1.4.2 *Tristimulus method performance requirements.*
- S14.4.1.4.2.1 *Red.*
- S14.4.1.4.2.2 *Yellow (Amber).*
- S14.4.1.4.2.3 *White (achromatic).*
- S14.4.2 *Plastic optical materials tests.*
- S14.4.2.1 *Samples.*
- S14.4.2.2 *Outdoor exposure test.*
- S14.4.2.2.3 *Procedure.*
- S14.4.2.2.4 *Performance requirements.*
- S14.4.2.3 *Heat test.*
- S14.4.2.3.1 *Procedure.*
- S14.4.2.3.2 *Performance requirements.*
- S14.5 *Signal lamp and reflective device physical test procedures and performance requirements.*
- S14.5.1 *Vibration test.*
- S14.5.1.1 *Procedure.*
- S14.5.1.2 *Performance requirements.*
- S14.5.2 *Moisture test.*
- S14.5.2.1 *Procedure.*
- S14.5.2.2 *Performance requirements.*
- S14.5.3 *Dust test.*
- S14.5.3.1 *Samples.*
- S14.5.3.2 *Procedure.*
- S14.5.3.3 *Performance requirements.*
- S14.5.4 *Corrosion test.*
- S14.5.4.1 *Procedure.*
- S14.5.4.2 *Performance requirements.*
- S14.6 *Headlamp physical test procedures and performance requirements.*
- S14.6.1 *Abrasion test.*
- S14.6.1.1 *Procedure.*
- S14.6.1.1.1 *Abrading pad.*
- S14.6.1.1.2 *Abrading pad alignment.*
- S14.6.1.1.3 *Abrasion test procedure.*
- S14.6.1.2 *Performance requirements.*
- S14.6.2 *Chemical resistance test.*
- S14.6.2.1 *Procedure.*
- S14.6.2.1.1 *Test fluids.*
- S14.6.2.1.2 *Fluid application.*
- S14.6.2.1.3 *Test duration.*
- S14.6.2.2 *Performance requirements.*
- S14.6.3 *Corrosion test.*
- S14.6.3.1 *Procedure.*
- S14.6.3.2 *Performance requirements.*
- S14.6.4 *Corrosion-connector test.*
- S14.6.4.1 *Procedure.*
- S14.6.4.2 *Performance requirements.*
- S14.6.5 *Dust test.*
- S14.6.5.1 *Procedure.*
- S14.6.5.2 *Performance requirements.*
- S14.6.6 *Temperature cycle test and internal heat test.*
- S14.6.6.1 *Samples.*
- S14.6.6.2 *General procedure.*
- S14.6.6.3 *Temperature cycle test.*
- S14.6.6.3.1 *Procedure.*
- S14.6.6.3.2 *Performance requirements.*
- S14.6.6.4 *Internal heat test.*
- S14.6.6.4.1 *Procedure.*
- S14.6.6.4.2 *Performance requirements.*
- S14.6.7 *Humidity test.*
- S14.6.7.1 *Procedure.*
- S14.6.7.2 *Performance requirements.*
- S14.6.8 *Vibration test.*
- S14.6.8.1 *Samples.*
- S14.6.8.2 *Procedure.*
- S14.6.8.3 *Performance requirements.*
- S14.6.9 *Sealing test.*
- S14.6.9.1 *Procedure.*
- S14.6.9.2 *Performance requirements.*
- S14.6.10 *Chemical resistance test of reflectors of replaceable lens headlamps.*
- S14.6.10.1 *Procedure.*
- S14.6.10.1.1 *Test fluids.*
- S14.6.10.1.2 *Fluid application.*
- S14.6.10.1.3 *Test duration.*
- S14.6.10.2 *Performance requirements.*
- S14.6.11 *Corrosion resistance test of reflectors of replaceable lens headlamps.*
- S14.6.11.1 *Procedure.*
- S14.6.11.2 *Performance requirements.*
- S14.6.12 *Inward force test.*
- S14.6.12.1 *Procedure.*
- S14.6.12.2 *Performance requirements.*
- S14.6.13 *Torque deflection test.*
- S14.6.13.1 *Procedure.*
- S14.6.13.2 *Performance requirements.*
- S14.6.14 *Retaining ring test.*
- S14.6.14.1 *Procedure.*
- S14.6.14.2 *Performance requirements.*
- S14.6.15 *Headlamp connector test.*
- S14.6.15.1 *Procedure.*
- S14.6.15.2 *Performance requirements.*
- S14.6.16 *Headlamp wattage test.*
- S14.6.16.1 *Procedure.*
- S14.6.16.2 *Performance requirements.*
- S14.6.17 *Aiming adjustment test-laboratory.*
- S14.6.17.1 *Procedure.*
- S14.6.17.2 *Performance requirements.*
- S14.6.18 *Aiming adjustment test-on vehicle.*
- S14.6.18.1 *Procedure.*
- S14.6.18.2 *Performance requirements.*
- S14.7 *Replaceable light source physical test procedures and performance requirements.*

- S14.7.1 *Deflection test for replaceable light sources.*
- S14.7.1.1 *Procedure.*
- S14.7.1.2 *Performance requirements.*
- S14.7.2 *Pressure test for replaceable light sources.*
- S14.7.2.1 *Procedure.*
- S14.7.2.2 *Performance requirements.*
- S14.7.3 *Replaceable light source power and flux measurement procedure.*
- S14.7.3.1 *Seasoning.*
- S14.7.3.1.1 *Resistive filament source.*
- S14.7.3.1.2 *Discharge source.*
- S14.7.3.2 *Test voltage.*
- S14.7.3.3 *Luminous flux measurement.*
- S14.7.3.3.3.2 *Discharge light source setup.*
- S14.8 *Vehicle headlamp aiming devices (VHAD) physical test procedures and performance requirements.*
- S14.8.1 *Samples.*
- S14.8.2 *Scale graduation test.*
- S14.8.2.1 *Procedure.*
- S14.8.2.2 *Performance requirements.*
- S14.8.3 *Cold scale graduation test.*
- S14.8.3.1 *Procedure.*
- S14.8.3.2 *Performance requirements.*
- S14.8.4 *Hot scale graduation test.*
- S14.8.4.1 *Procedure.*
- S14.8.4.2 *Performance requirements.*
- S14.8.5 *Thermal cycle test.*
- S14.8.5.1 *Procedure.*
- S14.8.5.2 *Performance requirements.*
- S14.8.6 *Corrosion test.*
- S14.8.6.1 *Procedure.*
- S14.8.6.2 *Performance requirements.*
- S14.8.7 *Photometry test.*
- S14.8.7.1 *Procedure.*
- S14.8.7.2 *Performance requirements.*
- S14.9 *Associated equipment physical test procedures and performance requirements.*
- S14.9.1 *Turn signal operating unit durability test.*
- S14.9.1.1 *Power supply specifications.*
- S14.9.1.2 *Procedure.*
- S14.9.1.3 *Performance requirements.*
- S14.9.2 *Vehicular hazard warning signal operating unit durability test.*
- S14.9.2.1 *Procedure.*
- S14.9.2.2 *Performance requirements.*
- S14.9.3 *Turn signal flasher and vehicular hazard warning flasher tests.*
- S14.9.3.1 *Standard test circuit.*
- S14.9.3.1.1 *Test circuit setup.*
- S14.9.3.2 *Power supply specifications.*
- S14.9.3.2.1 *Starting time, voltage drop, and flash rate and percent current "on" time tests.*
- S14.9.3.2.2 *Durability tests.*
- S14.9.3.3 *Turn signal flasher starting time test.*
- S14.9.3.3.1 *Samples.*
- S14.9.3.3.2 *Procedure.*
- S14.9.3.3.3 *Performance requirements.*
- S14.9.3.4 *Turn signal flasher voltage drop test.*
- S14.9.3.4.1 *Samples.*
- S14.9.3.4.2 *Procedure.*
- S14.9.3.4.3 *Performance requirements.*
- S14.9.3.5 *Turn signal flasher flash rate and percent current "on" time test.*
- S14.9.3.5.1 *Samples.*
- S14.9.3.5.2 *Procedure.*
- S14.9.3.5.3 *Performance requirements.*
- S14.9.3.6 *Turn signal flasher durability test.*
- S14.9.3.6.1 *Samples.*
- S14.9.3.6.2 *Procedure.*
- S14.9.3.6.3 *Performance requirements.*
- S14.9.3.7 *Vehicular hazard warning signal flasher starting time test.*
- S14.9.3.7.1 *Samples.*
- S14.9.3.7.2 *Procedure.*
- S14.9.3.7.3 *Performance requirements.*
- S14.9.3.8 *Vehicular hazard warning signal flasher voltage drop test.*
- S14.9.3.8.1 *Samples.*
- S14.9.3.8.2 *Procedure.*
- S14.9.3.8.3 *Performance requirements.*
- S14.9.3.9 *Vehicular hazard warning signal flasher flash rate and percent "on" time test.*
- S14.9.3.9.1 *Samples.*
- S14.9.3.9.2 *Procedure.*
- S14.9.3.9.3 *Performance requirements.*
- S14.9.3.10 *Vehicular hazard warning signal flasher durability test.*
- S14.9.3.10.1 *Samples.*
- S14.9.3.10.2 *Procedure.*
- S14.9.3.10.3 *Performance requirements.*
- S14.9.3.11 *Semiautomatic headlamp beam switching device tests.*
- S14.9.3.11.1 *Test conditions.*
- S14.9.3.11.2 *Sensitivity test.*
- S14.9.3.11.2.1 *Samples.*
- S14.9.3.11.2.2 *Procedure.*
- S14.9.3.11.2.3 *Performance requirements.*
- S14.9.3.11.2.3.1 *Operating limits.*
- S14.9.3.11.3 *Voltage regulation test.*
- S14.9.3.11.3.1 *Procedure.*
- S14.9.3.11.3.2 *Performance requirements.*
- S14.9.3.11.4 *Manual override test.*
- S14.9.3.11.4.1 *Procedure.*
- S14.9.3.11.4.2 *Performance requirements.*
- S14.9.3.11.5 *Warmup test.*
- S14.9.3.11.5.1 *Procedure.*
- S14.9.3.11.5.2 *Performance requirements.*
- S14.9.3.11.6 *Temperature test.*
- S14.9.3.11.6.1 *Procedure.*
- S14.9.3.11.6.2 *Performance requirements.*
- S14.9.3.11.7 *Dust test.*
- S14.9.3.11.7.1 *Procedure.*
- S14.9.3.11.7.2 *Performance requirements.*
- S14.9.3.11.8 *Corrosion test.*
- S14.9.3.11.8.1 *Procedure.*
- S14.9.3.11.8.2 *Performance requirements.*
- S14.9.3.11.9 *Vibration test.*
- S14.9.3.11.9.1 *Procedure.*
- S14.9.3.11.9.2 *Performance requirements.*
- S14.9.3.11.10 *Sunlight test.*
- S14.9.3.11.10.1 *Procedure.*
- S14.9.3.11.10.2 *Performance requirements.*
- S14.9.3.11.11 *Durability test.*
- S14.9.3.11.11.1 *Procedure.*
- S14.9.3.11.11.2 *Performance requirements.*
- S14.9.3.11.12 *Return to upper beam test.*
- S14.9.3.11.12.1 *Procedure.*
- S14.9.3.11.12.2 *Performance requirements.*
- Table I-a *Required lamps and reflective devices—All passenger cars, multipurpose passenger vehicles (MPV), trucks, and buses*
- Table I-b *Required lamps and reflective devices—All trailers*
- Table I-c *Required lamps and reflective devices—All motorcycles*
- Table II-a *Headlighting systems—Sealed beams*
- Table II-b *Headlighting systems—Combination*
- Table II-c *Headlighting systems—Integral beams*
- Table II-d *Headlighting systems—Replaceable bulb*
- Table III *Marking requirements location*
- Table IV-a *Effective projected luminous lens area requirements*
- Table IV-b *Effective projected luminous lens area requirements*
- Table IV-c *Effective projected luminous lens area requirements*
- Table V-a *Visibility requirements of installed lighting devices*
- Table V-b *Visibility requirements of installed lighting devices—Lens area visibility option*
- Table V-c *Visibility requirements of installed lighting devices—Luminous intensity visibility option*
- Table V-d *Visibility requirements of installed lighting devices (Legacy visibility alternative)*
- Table VI-a *Front turn signal lamp photometry requirements*
- Table VI-b *Front turn signal lamp photometry requirements*
- Table VII *Rear turn signal lamp photometry requirements*
- Table VIII *Taillamp photometry requirements*
- Table IX *Stop lamp photometry requirements*
- Table X *Side marker lamp photometry requirements*
- Table XI *Clearance and identification lamps photometry requirements*
- Table XII *Backup lamp photometry requirements*
- Table XIII-a *Motorcycle turn signal lamp alternative photometry requirements*
- Table XIII-b *Motor driven cycle stop lamp alternative photometry requirements*
- Table XIV *Parking lamp photometry requirements*
- Table XV *High-mounted stop lamp photometry requirements*
- Table XVI-a *Reflex reflector photometry requirements*
- Table XVI-b *Additional photometry requirements for conspicuity reflex reflectors*
- Table XVI-c *Retroreflective sheeting photometry requirements*
- Table XVII *School bus signal lamp photometry requirements*
- Table XVIII *Headlamp upper beam photometry requirements*
- Table XIX-a *Headlamp lower beam photometry requirements*
- Table XIX-b *Headlamp lower beam photometry requirements*
- Table XIX-c *Headlamp lower beam photometry requirements*
- Table XX *Motorcycle and motor driven cycle headlamp photometry requirements*
- Figure 1 *Chromaticity diagram*
- Figure 2 *Flasher performance chart*
- Figure 3 *Replaceable bulb headlamp aim pads*
- Figure 4 *Headlamp connector test setup*
- Figure 5 *Headlamp abrasion test fixture*
- Figure 6 *Thermal cycle test profile*
- Figure 7 *Dirt/Ambient test setup*
- Figure 8 *Replaceable light source deflection test setup*
- Figure 9 *Environmental test profile*
- Figure 10 *Replaceable light source pressure test setup*
- Figure 11 *Trailer conspicuity treatment examples*

Figure 12-1 *Trailer conspicuity detail I*
 Figure 12-2 *Trailer conspicuity detail II*
 Figure 13 *Tractor conspicuity treatment examples*
 Figure 14 *92x150 Headlamp aim deflection test setup*
 Figure 15 *Types G and H headlamp aim deflection test setup*
 Figure 16 *Types A and E headlamp aim deflection test setup*

Figure 17 *Type B headlamp aim deflection test setup*
 Figure 18 *Types C and D headlamp aim deflection test setup*
 Figure 19 *License plate lamp target locations*
 Figure 20 *License plate lamp measurement of incident light angle*
 Figure 21 *Vibration test machine*
 Figure 22 *Flasher standard test circuit*

Issued: August 8, 2007.
Nicole R. Nason,
Administrator.

Editorial Note: This document was received at the Office of the Federal Register on Thursday, November 8, 2007.

Note: The following appendixes will not appear in the Code of Federal Regulations.

APPENDIX A.—FMVSS NO. 108 REWRITE CROSS REFERENCE

Current FMVSS No. 108 or incorporated document citation	FMVSS No. 108 rewrite NPRM citation	FMVSS No. 108 rewrite final rule citation
S1 Scope	S1 Scope	S1 Scope.
S2 Purpose	S2 Purpose	S2 Purpose.
S3 Application (except section citation)	S3 Application	S3 Application.
S4 Definitions	S4 Definitions	S4 Definitions.
S4 Definitions—Aiming reference plane	S4 Definitions—Aiming reference plane	S4 Definitions—Aiming reference plane.
S4 Definitions—Axis of reference	S4 Definitions—Axis of reference	S4 Definitions—Axis of reference.
S4 Definitions—Beam contributor	S4 Definitions—Beam contributor	S4 Definitions—Beam contributor.
S4 Definitions—Cargo lamp	S4 Definitions—Cargo lamp	S4 Definitions—Cargo lamp.
S4 Definitions—Cutoff	S4 Definitions—Cutoff	S4 Definitions—Cutoff.
S4 Definitions—Direct reading indicator	S4 Definitions—Direct reading indicator	S4 Definitions—Direct reading indicator.
S4 Definitions—Effective light-emitting surface	S4 Definitions—Effective light-emitting surface	S4 Definitions—Effective light-emitting surface.
S4 Definitions—Effective projected luminous lens area.	S4 Definitions—Effective projected luminous lens area.	S4 Definitions—Effective projected luminous lens area.
S4 Definitions—Filament	S4 Definitions—Filament	S4 Definitions—Filament.
S4 Definitions—Flash	S4 Definitions—Flash	S4 Definitions—Flash.
S4 Definitions—Fully opened	S4 Definitions—Fully opened	S4 Definitions—Fully opened.
S4 Definitions—Headlamp concealment device	S4 Definitions—Headlamp concealment device.	S4 Definitions—Headlamp concealment device.
S4 Definitions—Headlamp test fixture	S4 Definitions—Headlamp test fixture	S4 Definitions—Headlamp test fixture.
S4 Definitions—Integral beam headlamp	S4 Definitions—Integral beam headlamp	S4 Definitions—Integral beam headlamp.
S4 Definitions—Multiple compartment lamp	S4 Definitions—Multiple compartment lamp	S4 Definitions—Multiple compartment lamp.
S4 Definitions—Multiple lamp arrangement	S4 Definitions—Multiple lamp arrangement	S4 Definitions—Multiple lamp arrangement.
S4 Definitions—Remote reading indicator	S4 Definitions—Remote reading indicator	S4 Definitions—Remote reading indicator.
S4 Definitions—Replaceable bulb headlamp	S4 Definitions—Replaceable bulb headlamp	S4 Definitions—Replaceable bulb headlamp.
S4 Definitions—Replaceable light source	S4 Definitions—Replaceable light source	S4 Definitions—Replaceable light source.
S4 Definitions—Vehicle headlamp aiming device or VHAD.	S4 Definitions—Vehicle headlamp aiming device or VHAD.	S4 Definitions—Vehicle headlamp aiming device or VHAD.
S4 Definitions—Visually/optically aimable headlamp.	S4 Definitions—Visually/optically aimable headlamp.	S4 Definitions—Visually/optically aimable headlamp.
S5.1.1	S6.1.1 Quantity	S6.1.1 Quantity.
S5.1.1	S6.6 Associated equipment	S6.6.1 All except trailers.
S5.1.1	S6.6 Associated equipment	S6.6.2 All except trailers and motorcycles.
S5.1.1.1 Truck tractor exemption—TS	S6.1.1.3 Truck tractor rear turn signal lamps	S6.1.1.3.
S5.1.1.1 Truck tractor exemption—TS	Table I Number and color	Table I—a Number and color.
S5.1.1.1 Truck tractor exemption—TS	Table VII footnote 6	Table VII footnote 6.
S5.1.1.2 Truck tractor exemption	Table I Number and color	Table I—a Number and color.
S5.1.1.3 Intermediate side marker exemption	Table I Number and color—Intermediate side marker lamps.	Table I—a Number and color—Intermediate side marker lamps.
S5.1.1.3 Intermediate side marker exemption	Table I Number and color—Intermediate side marker lamps.	Table I—b Number and color—Intermediate side marker lamps.
S5.1.1.3 Intermediate side marker exemption	S7.4.1.1 Inboard photometry	S7.4.13.2 Inboard photometry.
S5.1.1.4 Alternative side reflex material	S7.10.1.1 Alternative side reflex reflectors	S8.1.13 Alternative side reflex reflector material.
S5.1.1.4 Alternative side reflex material	Table I Lighting device	Table I—a Lighting device.
S5.1.1.4 Alternative side reflex material	Table I Lighting device	Table I—b Lighting device.
S5.1.1.4 Alternative side reflex material	Table I Lighting device	Table I—c Lighting device.
S5.1.1.5	S7.14.1 Turn signal operating unit	S9.1.1 Canceling.
S5.1.1.6	Table VIII footnote 2	Table VIII footnote 2.
S5.1.1.6	Table XIV footnote 2	Table XIV footnote 2.
S5.1.1.6	S7.2.1 Photometry	S7.2.13 Photometry.
S5.1.1.6	S7.8.1 Photometry	S7.8.13 Photometry.
S5.1.1.7 Motorcycle turn signal lamp	S7.1.2.1 Photometry	S7.1.2.13.2 Motorcycle alternative.
S5.1.1.7 Motorcycle turn signal lamp	S7.1.1.1; S7.1.2.1	Table XIII—a Motorcycle turn signal lamp—Individual point photometry.
S5.1.1.7 Motorcycle turn signal lamp	S7.1.1.1; S7.1.2.1	Table XIII—a Motorcycle turn signal lamp—Group photometry.
S5.1.1.7 Motorcycle turn signal lamp	S7.1.1.1; S7.1.2.1	Table XIII—a Motorcycle turn signal lamp—Photometric ratio.
S5.1.1.7 Motorcycle turn signal lamp	S7.1.1.1 Photometry	S7.1.1.13 Photometry.

APPENDIX A.—FMVSS NO. 108 REWRITE CROSS REFERENCE—Continued

Current FMVSS No. 108 or incorporated document citation	FMVSS No. 108 rewrite NPRM citation	FMVSS No. 108 rewrite final rule citation
S5.1.1.7 Motorcycle turn signal lamp	S7.1.1.1 Photometry	S7.1.1.13.1.
S5.1.1.7 Motorcycle turn signal lamp	S7.1.1.1 Photometry	S7.1.1.13.2.
S5.1.1.8 Inboard photometry	S7.4.1.1 Inboard photometry	S7.4.13.2 Inboard photometry.
S5.1.1.8 Inboard photometry	Table X footnote 1	Table X footnote 1.
S5.1.1.9 Boat trailer exemption	Table I Number and color—Clearance lamp ...	Table I—b Number and color—Clearance lamp.
S5.1.1.10 Multiple license plate lamps and backup lamps.	S6.1.1 Quantity	S6.1.1 Quantity.
S5.1.1.10 Multiple license plate lamps and backup lamps.	Table I Number and color	Table I—a Number and color.
S5.1.1.10 Multiple license plate lamps and backup lamps.	Table I Number and color	Table I—b Number and color.
S5.1.1.10 Multiple license plate lamps and backup lamps.	Table I Number and color	Table I—c Number and color.
S5.1.1.11 Stop lamp and turn signal lamp activation interaction.	S4 Definitions—Optically combined	S4 Definitions—Optically combined.
S5.1.1.11 Stop lamp and turn signal lamp activation interaction.	S6.1.5 Activation	S6.1.5 Activation.
S5.1.1.11 Stop lamp and turn signal lamp activation interaction.	Table I Activation—Stop lamps	Table I—a Activation—Stop lamps.
S5.1.1.11 Stop lamp and turn signal lamp activation interaction.	Table I Activation—Stop lamps	Table I—b Activation—Stop lamps.
S5.1.1.12	S7.1.1.3.1 Lamps installed on vehicles 2032 mm or more in overall width.	S7.1.1.11.4 Lamps installed on vehicles 2032 mm or more in overall width.
S5.1.1.12	S7.1.2.2.1 Lamps installed on vehicles 2032 mm or more in overall width.	S7.1.2.11.4 Lamps installed on vehicles 2032 mm or more in overall width.
S5.1.1.12	S7.3.1.1.1 Lamps installed on vehicles 2032 mm or more in overall width.	S7.3.11.4 Lamps installed on vehicles 2032 mm or more in overall width.
S5.1.1.13	Table XXI Turn signal operating unit durability test—performance requirements.	S14.9.1.3.1 Voltage drop (<2032 mm wide).
S5.1.1.13	Table XXI Turn signal operating unit durability test—performance requirements.	S14.9.1.3 Performance requirements.
S5.1.1.14 Trailer exemption—rear	Table I Number and color	Table I—b Number and color.
S5.1.1.15 Trailer exemption—front	Table I Number and color	Table I—b Number and color.
S5.1.1.16	S6.8.5.2.1 Bulbs without MSCD	S14.2.1.6.1 Bulbs without MSCD.
S5.1.1.17	S6.8.5.2 Bulbs	S14.2.1.6 Bulbs.
S5.1.1.17	S6.8.5.2 Bulbs	S14.2.2.3 Bulbs.
S5.1.1.17	S6.8.5.2 Bulbs	S14.2.4.3 Bulbs.
S5.1.1.18 Backup lamp photometry	Table XII Single backup lamp system—Individual point photometry.	Table XII Single lamp system—Individual point photometry.
S5.1.1.18 Backup lamp photometry	Table XII Two backup lamp system—Individual point photometry.	Table XII Two lamp systems Each lamp—Individual point photometry.
S5.1.1.18 Backup lamp photometry	Table XII footnote 4	Table XII footnote 4.
S5.1.1.19 Variable load turn signal flasher	Table XXI Turn signal flasher starting time test—procedure.	S14.9.3.3.2.1 Setup.
S5.1.1.19 Variable load turn signal flasher	Table XXI Turn signal flasher voltage drop test—procedure.	S14.9.3.4.2.1 Setup.
S5.1.1.19 Variable load turn signal flasher	Table XXI Turn signal flasher flash rate and percent current “on” time test—procedure.	S14.9.3.5.2.1 Setup.
S5.1.1.20 Flasher voltage drop	Table XXI Turn signal flasher voltage drop test—performance requirements.	S14.9.3.4.3 Performance requirements.
S5.1.1.20 Flasher voltage drop	Table XXI Vehicular hazard warning signal flasher voltage drop test—performance requirements.	S14.9.3.8.3 Performance requirements.
S5.1.1.21 Motor driven cycle turn signal exemption.	Table I Number and color	Table I—c Number and color.
S5.1.1.22 Motor driven cycle stop lamp exemptions.	S6.4.1 Effective projected luminous lens area requirements.	S6.4.1 Effective projected luminous lens area requirements.
S5.1.1.22 Motor driven cycle stop lamp exemptions.	Table IV Stop lamp—Effective projected luminous lens area.	Table IV—a Stop lamp—Effective projected luminous lens area.
S5.1.1.22 Motor driven cycle stop lamp exemptions.	Table IV footnote 1	Table IV footnote 1.
S5.1.1.22 Motor driven cycle stop lamp exemptions.	Table IX Motor driven cycle stop lamp zone photometry.	Table XIII—b Motor driven cycle stop lamp—Group photometry.
S5.1.1.22 Motor driven cycle stop lamp exemptions.	S7.3.1 Photometry	S7.3.13.2 Motor driven cycle alternative.
S5.1.1.22 Motor driven cycle stop lamp exemptions.	Table IX footnote 5	Table XIII—b footnote 3.
S5.1.1.25 Motor cycle turn signal lamp EPLLA	S6.4.1 Effective projected luminous lens area requirements.	S6.4.1 Effective projected luminous lens area requirements.

APPENDIX A.—FMVSS NO. 108 REWRITE CROSS REFERENCE—Continued

Current FMVSS No. 108 or incorporated document citation	FMVSS No. 108 rewrite NPRM citation	FMVSS No. 108 rewrite final rule citation
S5.1.1.25 Motor cycle turn signal lamp EPLLA	Table IV Front turn signal lamp—Effective projected luminous lens area.	Table IV—a Front turn signal lamp—Effective projected luminous lens area.
S5.1.1.25 Motor cycle turn signal lamp EPLLA	Table IV Rear turn signal lamp—Effective projected luminous lens area.	Table IV—a Rear turn signal lamp—Effective projected luminous lens area.
S5.1.1.26(a)	S6.4.1 Effective projected luminous lens area requirements.	S6.4.1 Effective projected luminous lens area requirements.
S5.1.1.26(a)	Table IV Rear turn signal lamp—Effective projected luminous lens area.	Table IV—a Rear turn signal lamp—Effective projected luminous lens area.
S5.1.1.26(a)	Table IV Stop lamp—Effective projected luminous lens area.	Table IV—a Stop lamp—Effective projected luminous lens area.
S5.1.1.26(b)	S6.4.1 Effective projected luminous lens area requirements.	S6.4.1 Effective projected luminous lens area requirements.
S5.1.1.26(b)	Table IV Rear turn signal lamp—Effective projected luminous lens area.	Table IV—a Rear turn signal lamp—Effective projected luminous lens area.
S5.1.1.26(b)	Table IV Stop lamp—Effective projected luminous lens area.	Table IV—a Stop lamp—Effective projected luminous lens area.
S5.1.1.27(a)	S6.1.1.2 High mounted stop lamp	S6.1.1.2 High mounted stop lamp.
S5.1.1.27(a)	Table I Lighting device	Table I—a Lighting device.
S5.1.1.27(a)(1)	S6.4.1 Effective projected luminous lens area requirements.	S6.4.1 Effective projected luminous lens area requirements.
S5.1.1.27(a)(1)	Table IV High mounted stop lamp—Effective projected luminous lens area.	Table IV—b High mounted stop lamp—Effective projected luminous lens area.
S5.1.1.27(a)(2)	Table V HMSL—Visibility	Table V—a HMSL—Visibility.
S5.1.1.27(a)(3)	S7.9.3 Photometry	S7.9.13 Photometry.
S5.1.1.27(b)(3)	S7.9.3 Photometry	S7.9.13 Photometry.
S5.1.1.27(a)(4)	S7.9.4 Physical tests	S7.9.14 Physical tests.
S5.1.1.27(a)(4)	S7.9.4 Physical tests	S7.9.14.1 External mount.
S5.1.1.27(a)(4)	S7.9.4 Physical tests	S7.9.14.2 Internal mount.
S5.1.1.27(a)(5)	S7.9.1 High mounted stop lamp design	S6.1.4.1.3 Accessibility.
S5.1.1.27(b)	S6.1.1.2 High mounted stop lamp	S6.1.1.2 High mounted stop lamp.
S5.1.1.27(b)	Table I Lighting device	Table I—a Lighting device.
S5.1.1.27(b)(1)	S6.1.1.2 High mounted stop lamp	S6.1.1.2 High mounted stop lamp.
S5.1.1.27(b)(1)	S6.4.1 Effective projected luminous lens area requirements.	S6.4.1 Effective projected luminous lens area requirements.
S5.1.1.27(b)(1)	Table IV High mounted stop lamp—Effective projected luminous lens area.	Table IV—b High mounted stop lamp—Effective projected luminous lens area.
S5.1.1.27(b)(2)	Table V HMSL—Visibility	Table V—a HMSL—Visibility.
S5.1.1.27(b)(3)	Table XV footnote 3	Table XV footnote 3.
S5.1.1.27(b)(4)	S7.9.1 High mounted stop lamp design	S6.1.4.1.3 Accessibility.
S5.1.1.29 Conspicuity system replace reflex on trailers.	S6.1.1.1.1 Conspicuity and reflex	Table I—b Reflex reflectors.
S5.1.2 Plastic optical materials	S6.8.4 Plastic optical materials	S14.1.2 Plastic optical materials.
S5.1.2 Plastic optical materials	S7.1.3 Physical tests	S7.1.1.14 Physical tests.
S5.1.2 Plastic optical materials	S7.1.3 Physical tests	S7.1.2.14 Physical tests.
S5.1.2 Plastic optical materials	S7.2.2 Physical tests	S7.2.14 Physical tests.
S5.1.2 Plastic optical materials	S7.3.2 Physical tests	S7.3.14 Physical tests.
S5.1.2 Plastic optical materials	S7.4.2 Physical tests	S7.4.14 Physical tests.
S5.1.2 Plastic optical materials	S7.5.2 Physical tests	S7.5.14 Physical tests.
S5.1.2 Plastic optical materials	S7.6.3 Physical tests	S7.6.14 Physical tests.
S5.1.2 Plastic optical materials	S7.7.3 Physical tests	S7.7.14 Physical tests.
S5.1.2 Plastic optical materials	S7.8.2 Physical tests	S7.8.14 Physical tests.
S5.1.2 Plastic optical materials	S7.9.4 Physical tests	S7.9.14 Physical tests.
S5.1.2 Plastic optical materials	S7.9.4 Physical tests	S7.9.14.1 External mount.
S5.1.2 Plastic optical materials	S7.9.4 Physical tests	S7.9.14.2 Internal mount.
S5.1.2 Plastic optical materials	S7.10.2 Physical tests	S8.1.12 Physical tests.
S5.1.2 Plastic optical materials	S7.11.3 Physical tests	S7.10.14 Physical tests.
S5.1.2 Plastic optical materials	S7.13.2 Physical test requirements	S7.11.14 Physical tests.
S5.1.2 Plastic optical materials	S9.4 Physical tests	S10.13.4.3 Material test.
S5.1.2 Plastic optical materials	S10.7 Physical tests	S10.14.7.8 Material test.
S5.1.2 Plastic optical materials	S11.7 Physical tests	S10.15.7.7 Material test.
S5.1.2(a)	Table XXII Plastic optical material tests—performance requirements.	S14.4.2.2.4 Performance requirements.
S5.1.2(b)	Table XXII Plastic optical material tests—performance requirements.	S14.4.2.2.4.1(a) Except reflex.
S5.1.2(b)	Table XXII Plastic optical material tests—performance requirements.	S14.4.2.2.4.1 Haze.
S5.1.2(c)	Table XXII Plastic optical material tests—performance requirements.	S14.4.2.2.4.1 Haze.
S5.1.2(c)	Table XXII Plastic optical material tests—performance requirements.	S14.4.2.2.4.1(b) Reflex.

APPENDIX A.—FMVSS NO. 108 REWRITE CROSS REFERENCE—Continued

Current FMVSS No. 108 or incorporated document citation	FMVSS No. 108 rewrite NPRM citation	FMVSS No. 108 rewrite final rule citation
S5.1.2(c)	Table XXII Plastic optical material tests—performance requirements.	S14.4.2.2.4.3 Physical changes.
S5.1.2(d)	Table XXII Plastic optical material tests—samples.	S14.4.2.1.3 Thickness.
S5.1.2(e)	Table XXII Plastic optical material tests—performance requirements.	S14.4.2.3.2 Performance requirements.
S5.1.2(e)	Table XXII Plastic optical material tests	S14.4.2.3 Heat test.
S5.1.2(f)	Table XXII Plastic optical material tests	S14.4.2.3 Heat test.
S5.1.2(f)	Table XXII Plastic optical material tests—procedure.	S14.4.2.3.1 Procedure.
S5.1.2(g)	Table XXII Plastic optical material tests	S14.4.2.2.1 Location and duration.
S5.1.3 Impairment	S6.2.1 Impairment due to additional lamps or reflective devices.	S6.2.1 Impairment due to additional lamps or reflective devices.
S5.1.4 School bus signal lamps	Table I Additional Lamps Required on All School Buses except Multifunction School Activity Buses.	Table I—a Additional Lamps Required on All School Buses except Multifunction School Activity Buses.
S5.1.4(a)	Table I Number and color—School bus signal lamps.	Table I—a Number and color—School bus signal lamps.
S5.1.4(b)	Table XVII Amber lamp photometry	Table XVII Amber lamp photometry.
S5.1.4(b)(i)	Table I Number and color—School bus signal lamps.	Table I—a Number and color—School bus signal lamps.
S5.1.4(b)(ii)	Table I Activation—School bus signal lamps ..	Table I—a Activation—School bus signal lamps.
S5.1.4(b)	S7.13.1 Photometry	S7.11.13 Photometry.
S5.1.5 Color	S6.1.2 Color	S6.1.2 Color.
S5.1.5 Color	S7.1.3 Physical tests	S7.1.1.14 Physical tests.
S5.1.5 Color	S7.1.3 Physical tests	S7.1.2.14 Physical tests.
S5.1.5 Color	S7.2.2 Physical tests	S7.2.14 Physical tests.
S5.1.5 Color	S7.3.2 Physical tests	S7.3.14 Physical tests.
S5.1.5 Color	S7.4.2 Physical tests	S7.4.14 Physical tests.
S5.1.5 Color	S7.5.2 Physical tests	S7.5.14 Physical tests.
S5.1.5 Color	S7.6.3 Physical tests	S7.6.14 Physical tests.
S5.1.5 Color	S7.7.3 Physical tests	S7.7.14 Physical tests.
S5.1.5 Color	S7.8.2 Physical tests	S7.8.14 Physical tests.
S5.1.5 Color	S7.10.2 Physical tests	S8.1.12 Physical tests.
S5.1.5 Color	S7.11.3 Physical tests	S7.10.14 Physical tests.
S5.1.5 Color	S7.13.2 Physical test requirements	S7.11.14 Physical tests.
S5.1.5 Color	S7.9.4 Physical tests	S7.9.14 Physical tests.
S5.1.5 Color	S7.9.4 Physical tests	S7.9.14.1 External mount.
S5.1.5 Color	S7.9.4 Physical tests	S7.9.14.2 Internal mount.
S5.1.5 Color	S9.4 Physical tests	S10.13.4.3 Color test.
S5.1.5 Color	S10.7 Physical tests	S10.14.7.8 Color test.
S5.1.5 Color	S11.7 Physical tests	S10.15.7.7 Color test.
S5.1.5 Color	Table XXII Color test—performance requirements.	S14.4.1.3.2 Performance requirements.
S5.1.5 Color	Table XXII Color test—performance requirements.	S14.4.1.4.2 Performance requirements.
S5.2.1	S5.1 SAE Publications	S5.1 SAE Publications.
S5.2.2	S17.3 Sealed beam headlamp markings	S6.5.3.3 Sealed beam headlamp markings.
S5.3 Location	S6.1.3 Mounting location and height	S6.1.3.1.
S5.3 Location	S6.1.3 Mounting location and height	S6.1.3.2.
S5.3.1.2 Truck tractor rear reflex	Table I Mounting location—Reflex reflectors ...	Table I—a Mounting location—Reflex reflectors.
S5.3.1.3 Trailer front reflex and side marker	Table I Mounting location—Reflex reflectors ...	Table I—b Mounting location—Reflex reflectors.
S5.3.1.3 Trailer front reflex and side marker	Table I Mounting location—Side marker lamps	Table I—b Mounting location—Side marker lamps.
S5.3.1.4 Rear clearance lamp mounting	Table I Mounting height—Clearance lamps	Table I—a Mounting height—Clearance lamps.
S5.3.1.4 Rear clearance lamp mounting	Table I Mounting height—Clearance lamps	Table I—b Mounting height—Clearance lamps.
S5.3.1.6 Truck tractor clearance lamps	Table I Mounting location—Clearance lamps ..	Table I—a Mounting location—Clearance lamps.
S5.3.1.7 Turn signal spacing	Table VI Front turn signal lamp—2.5 × base zone photometry.	Table VI—a Front turn signal lamp—2.5 × base group photometry.
S5.3.1.7 Turn signal spacing	Table VI Front turn signal lamp—2.5 × base individual point photometry.	Table VI—a Front turn signal lamp—2.5 × base individual point photometry.
S5.3.1.7 Turn signal spacing	S7.1.1.2.3 Spacing based photometric multipliers.	S7.1.1.10.4 Spacing based photometric multipliers.
S5.3.1.8(a)(1)	Table I Mounting location—High mounted stop lamp.	Table I—a Mounting location—High-mounted stop lamp.
S5.3.1.8(a)(2)	S6.1.3.2.1 High mounted stop lamp mounting	S6.1.4.1.1 High-mounted stop lamp mounting.
S5.3.1.8(a)(3)	S7.9.2 Interior mounting	S6.1.4.1.2.

APPENDIX A.—FMVSS NO. 108 REWRITE CROSS REFERENCE—Continued

Current FMVSS No. 108 or incorporated document citation	FMVSS No. 108 rewrite NPRM citation	FMVSS No. 108 rewrite final rule citation
S5.3.1.8(a)(3)	S6.1.3.2.2. High mounted stop lamp reflections.	S6.1.4.1.2. High-mounted stop lamp reflections.
S5.3.1.8(b)	S6.1.1.2 High mounted stop lamp	S6.1.1.2.1 High-mounted stop lamp.
S5.3.2(a)	S6.2.1 Impairment due to additional lamps or reflective devices.	S6.2.1 Impairment due to additional lamps or reflective devices.
S5.3.2(b)	S6.4.3 Visibility options	S6.4.3 Visibility requirement options.
S5.3.2(b)(1)	S6.4.3(a) Lens area option	S6.4.3(a) Lens area option.
S5.3.2(b)(1)	Table V Lens area visibility	Table V—c Lens area visibility.
S5.3.2(b)(2)	S6.4.3(b) Luminous intensity option	S6.4.3(b) Luminous intensity option.
S5.3.2(b)(2)	Table V Luminous intensity visibility	Table V—d Luminous intensity visibility.
S5.3.2(c)	S6.4.2 Visibility	S6.4.2 Visibility.
S5.3.2(c)	Table V High mounted stop lamp visibility	Table V—a High mounted stop lamp visibility.
S5.3.2(d)	S6.4.2 Visibility	S6.4.2 Visibility.
S5.3.2(d)	Table V High mounted stop lamp visibility	Table V—a High mounted stop lamp visibility.
S5.3.2(e)	S6.4.2 Visibility	S6.4.2 Visibility.
S5.3.2(e)	Table V Backup lamp visibility	Table V—a Backup lamp visibility.
S5.3.2.1	Table I Mounting location—Clearance lamps	Table I—a Mounting location—Clearance lamps.
S5.3.2.1	Table I Mounting location—Clearance lamps	Table I—b Mounting location—Clearance lamps.
S5.3.2.1	Table XI footnote 4	Table XI footnote 4.
S5.3.2.2	S6.2.2 Lamp or reflective device obstructed	S6.2.2 Lamp or reflective device obstructed.
S5.3.2.3	Table V footnote 2	Table V footnote 2.
S5.3.2.3	Table VI footnote 3	Table VI footnote 3.
S5.3.2.3	Table VII footnote 3	Table VII footnote 3.
S5.3.2.3	Table VIII footnote 3	Table VIII footnote 3.
S5.3.2.3	Table IX footnote 4	Table IX footnote 4.
S5.3.2.3	Table X footnote 3	Table X footnote 3.
S5.3.2.3	Table XI footnote 1	Table XI footnote 1.
S5.3.2.3	Standard note—new table	Table XIII—a footnote 4.
S5.3.2.3	Table XIV footnote 3	Table XIV footnote 3.
S5.3.2.3	Table XVI footnote 1	Table XVI—a footnote 1.
S5.3.2.3	Table XVII footnote 1	Table XVII footnote 1.
S5.3.2.4	S6.4.4 SAE visibility alternative to S6.4.3	S6.4.4 Legacy visibility option.
S5.4 Equipment combinations	S6.3 Equipment combinations	S6.3 Equipment combinations.
S5.4(a)	S6.3.1 High mounted stop lamp and cargo lamp.	S6.3.1 High-mounted stop lamp and cargo lamp.
S5.4(b)	S4 Definitions—Optically combined	S4 Definitions—Optically combined.
S5.4(b)	S6.3.2 Optically combined HSML and cargo lamp prohibition.	S6.3.2 Optically combined HSML and cargo lamp prohibition.
S5.4(c)	S4 Definitions—Optically combined	S4 Definitions—Optically combined.
S5.4(c)	S6.3.3. Clearance lamp and taillamp	S6.3.3. Clearance lamp and taillamp.
S5.5.1 Headlamp beam switching	S7.14.4 Headlamp beam switching device	S9.4 Headlamp beam switching device.
S5.5.1 Headlamp beam switching	S7.14.4.1 Semi-automatic headlamp beam switching device.	S9.4.1 Semi-automatic headlamp beam switching device.
S5.5.2 Upper beam indicator	S7.14.5 Upper beam headlamp indicator	S9.5 Upper beam headlamp indicator.
S5.5.2 Upper beam indicator	S7.14.5.1 Indicator size and location	S9.5.1 Indicator size, location, and color.
S5.5.3	S6.1.5 Activation	S6.1.5 Activation.
S5.5.3	Table I Activation—Taillamps	Table I—a Activation—Taillamps.
S5.5.3	Table I Activation—Taillamps	Table I—c Activation—Taillamps.
S5.5.4	Table I Activation—High mounted stop lamps	Table I—a Activation—High mounted stop lamps.
S5.5.4	Table I Activation—Stop lamps	Table I—a Activation—Stop lamps.
S5.5.4	Table I Activation—Stop lamps	Table I—b Activation—Stop lamps.
S5.5.4	Table I Activation—Stop lamps	Table I—c Activation—Stop lamps.
S5.5.5	S6.1.1.4 Hazard warning lamps	S6.1.5.1 Hazard warning signal.
S5.5.5	S7.14.6.1 Operating unit switch	S9.6.2 Operation.
S5.5.6	S7.14.3.2 Turn signal lamp failure	S9.3.6 Turn signal lamp failure.
S5.5.6	S7.14.3 Turn signal pilot indicator	S9.3 Turn signal pilot indicator.
S5.5.6	S7.14.3 Turn signal pilot indicator	S9.3.1 TS lamps not visible.
S5.5.6	S7.14.3 Turn signal pilot indicator	S9.3.2 Indicator light(s).
S5.5.6	S7.14.3 Turn signal pilot indicator	S9.3.3 Function.
S5.5.7	S6.1.5 Activation	S6.1.5 Activation.
S5.5.7(a)	Table I Activation—Taillamps	Table I—a Activation—Taillamps.
S5.5.7(a)	Table I Activation—License plate lamps	Table I—a Activation—License plate lamps.
S5.5.7(a)	Table I Activation—Parking lamps	Table I—a Activation—Parking lamps.
S5.5.7(a)	Table I Activation—Side marker lamps	Table I—a Activation—Side marker lamps.
S5.5.7(a)	Table I Activation—Taillamps	Table I—c Activation—Taillamps.
S5.5.7(a)	Table I Activation—License plate lamps	Table I—c Activation—License plate lamps.
S5.5.7(b)	Table I Activation—Taillamps	Table I—a Activation—Taillamps.
S5.5.7(b)	Table I Activation—License plate lamps	Table I—a Activation—License plate lamps.

APPENDIX A.—FMVSS NO. 108 REWRITE CROSS REFERENCE—Continued

Current FMVSS No. 108 or incorporated document citation	FMVSS No. 108 rewrite NPRM citation	FMVSS No. 108 rewrite final rule citation
S5.5.7(b)	Table I Activation—Parking lamps	Table I-a Activation—Parking lamps.
S5.5.7(b)	Table I Activation—Side marker lamps	Table I-a Activation—Side marker lamps.
S5.5.7(b)	Table I Activation—Taillamps	Table I-c Activation—Taillamps.
S5.5.7(b)	Table I Activation—License plate lamps	Table I-c Activation—License plate lamps.
S5.5.8	S8.2 Simultaneous beam activation	S6.1.5.2.1.
S5.5.8	S8.2 Simultaneous beam activation	S6.1.5.2.2.
S5.5.8	Table I Activation—Headlamp	Table I-a Activation—Headlamp.
S5.5.8	Table II footnote 1	Table II footnote 1.
S5.5.8	Table II footnote 3	Table II footnote 3.
S5.5.8	Table II footnote 4	Table II footnote 4.
S5.5.8	Table II footnote 5	Table II footnote 5.
S5.5.9	Table I Activation—Headlamp	Table I-a Activation—Headlamp.
S5.5.9	Table I Activation—Headlamp	Table I-c Activation—Headlamp.
S5.5.9	Table I Activation—Motorcycle headlamps	Table I-c Activation—Motorcycle headlamps.
S5.5.10(a)	S6.1.5 Activation	S6.1.5 Activation.
S5.5.10(a)	Table I Activation—School bus signal lamps	Table I-a Activation—School bus signal lamps.
S5.5.10(a)	Table I Activation—Turn signals	Table I-a Activation—Turn signals.
S5.5.10(a)	Table I Activation—Turn signals	Table I-b Activation—Turn signals.
S5.5.10(a)	Table I Activation—Turn signals	Table I-c Activation—Turn signals.
S5.5.10(b)	S6.1.5 Activation	S6.1.5 Activation.
S5.5.10(b)	Table I Activation—Headlamp	Table I-a Activation—Headlamp.
S5.5.10(b)	Table I Activation—Side marker lamps	Table I-a Activation—Side marker lamps.
S5.5.10(b)	Table I Activation—Side marker lamps	Table I-b Activation—Side marker lamps.
S5.5.10(b)	Table I Activation—Motorcycle headlamps	Table I-c Activation—Motorcycle headlamps.
S5.5.10(c)	Table I Activation—Motorcycle headlamps	Table I-c Activation—Motorcycle headlamps.
S5.5.10(d)	S6.1.5 Activation	S6.1.5 Activation.
S5.5.10(d)	Table I Activation—Taillamps	Table I-a Activation—Taillamps.
S5.5.10(d)	Table I Activation—Backup lamps	Table I-a Activation—Backup lamps.
S5.5.10(d)	Table I Activation—Clearance lamps	Table I-a Activation—Clearance lamps.
S5.5.10(d)	Table I Activation—DRL	Table I-a Activation—DRL.
S5.5.10(d)	Table I Activation—Headlamp	Table I-a Activation—Headlamp.
S5.5.10(d)	Table I Activation—High mounted stop lamps	Table I-a Activation—High mounted stop lamps.
S5.5.10(d)	Table I Activation—Identification lamps	Table I-a Activation—Identification lamps.
S5.5.10(d)	Table I Activation—License plate lamps	Table I-a Activation—License plate lamps.
S5.5.10(d)	Table I Activation—Parking lamps	Table I-a Activation—Parking lamps.
S5.5.10(d)	Table I Activation—Side marker lamps	Table I-a Activation—Side marker lamps.
S5.5.10(d)	Table I Activation—Taillamps	Table I-b Activation—Taillamps.
S5.5.10(d)	Table I Activation—Clearance lamps	Table I-b Activation—Clearance lamps.
S5.5.10(d)	Table I Activation—Side marker lamps	Table I-b Activation—Side marker lamps.
S5.5.10(d)	Table I Activation—Stop lamps	Table I-b Activation—Stop lamps.
S5.5.10(d)	Table I Activation—Taillamps	Table I-c Activation—Taillamps.
S5.5.10(d)	Table I Activation—Headlamp	Table I-c Activation—Headlamp.
S5.5.10(d)	Table I Activation—License plate lamps	Table I-c Activation—License plate lamps.
S5.5.10(d)	Table I Activation—Stop lamps	Table I-c Activation—Stop lamps.
S5.5.11(a) Daytime running lamps (DRL)	S6.2.4 Daytime running lamps (DRL)	S6.1.1.4 Daytime running lamps (DRL).
S5.5.11(a) Daytime running lamps (DRL)	Table I Activation—DRL	Table I-a Activation—DRL.
S5.5.11(a) Daytime running lamps (DRL)	Table I Lighting device	Table I-a Lighting device.
S5.5.11(a)(1)	S7.11.1 Photometry	S7.10.13 Photometry.
S5.5.11(a)(1)(i)	S7.11.1(a)	S7.10.13(a).
S5.5.11(a)(1)(ii)	S7.11.1(b)	S7.10.13(b).
S5.5.11(a)(2)	S6.5.2 DRL marking	S6.5.2 DRL marking.
S5.5.11(a)(3)	S7.11.3 Physical tests	S7.10.14 Physical tests.
S5.5.11(a)(3)	Table I Lighting device	Table I-a Lighting device.
S5.5.11(a)(3)	Table I Number and color	Table I-a Number and color.
S5.5.11(a)(4)	S7.11.2 Spacing to turn signal lamps	S7.10.10 Spacing to other lamps.
S5.5.11(a)(4)(i)	S7.11.2.2(a) Not optically combined with turn signal lamp.	S7.10.10.1(a).
S5.5.11(a)(4)(iii)	S7.11.2.2(b) Not optically combined with turn signal lamp.	S7.10.10.1(b).
S5.5.11(a)(4)(iv)	S7.11.2.2(c) Not optically combined with turn signal lamp.	S7.10.10.1(c).
S5.5.11(a)(5)	Table I Activation—DRL	Table I-a Activation—DRL.
S5.5.11(b)	Table I Lighting device	Table I-a Lighting device.
S5.5.11(b)	Table I Mounting height	Table I-a Mounting height.
S5.7 Conspicuity systems	S6.1.1.1 Conspicuity systems	S6.1.1.1 Conspicuity systems.
S5.7.1 Retroreflective sheeting	S6.1.1.1 Conspicuity systems	S6.1.1.1 Conspicuity systems.
S5.7.1 Retroreflective sheeting	S7.12.1 Retroreflective sheeting	S8.2.1 Retroreflective sheeting.
S5.7.1.1 Construction	S7.12.1 Retroreflective sheeting	S8.2.1.1 Construction.
S5.7.1.2 Performance requirements	S6.8.5 Photometric tests	S14.2 Photometric test procedures.

APPENDIX A.—FMVSS NO. 108 REWRITE CROSS REFERENCE—Continued

Current FMVSS No. 108 or incorporated document citation	FMVSS No. 108 rewrite NPRM citation	FMVSS No. 108 rewrite final rule citation
S5.7.1.2 Performance requirements	S6.8.5.4.1 Reflex reflector and retroreflective sheeting photometry measurements.	S14.2.3.8.2 Retroreflective sheeting.
S5.7.1.2 Performance requirements	S7.12.1.2 Photometry	S8.2.1.7 Photometry.
S5.7.1.2 Performance requirements	Table XVI Red C2 sheeting photometry	Table XVI-c Red C2 sheeting photometry.
S5.7.1.2 Performance requirements	Table XVI Red C3 sheeting photometry	Table XVI-c Red C3 sheeting photometry.
S5.7.1.2 Performance requirements	Table XVI Red C4 sheeting photometry	Table XVI-c Red C4 sheeting photometry.
S5.7.1.2 Performance requirements	Table XVI White C2 sheeting photometry	Table XVI-c White C2 sheeting photometry.
S5.7.1.2 Performance requirements	Table XVI White C3 sheeting photometry	Table XVI-c White C3 sheeting photometry.
S5.7.1.2 Performance requirements	Table XVI White C4 sheeting photometry	Table XVI-c White C4 sheeting photometry.
S5.7.1.2 Performance requirements	S7.12.1 Retroreflective sheeting	S8.2.1.2 Performance requirements.
S5.7.1.3 Sheeting pattern, dimensions, and relative coefficients of retroreflection.	Table III Application pattern—Alternating—Retroreflective sheeting.	S8.2.1.4.1 Alternating red and white materials.
S5.7.1.3(b)	Table III Application pattern—Alternating—Retroreflective sheeting.	S8.2.1.4.1.1 Segments.
S5.7.1.3(c)	Table III Application pattern—Alternating—Retroreflective sheeting.	S8.2.1.4.1.2 Proportion.
S5.7.1.3(d)	S7.12.1 Retroreflective sheeting	S8.2.1.2 Performance requirements.
S5.7.1.4(a)	Table III Application location—Retroreflective sheeting.	S8.2.1.5 Application location.
S5.7.1.4(b)	Table III Application spacing—Retroreflective sheeting.	S8.2.1.6 Application spacing.
S5.7.1.4(c)	Table III Application spacing—Retroreflective sheeting.	S8.2.1.6 Application spacing.
S5.7.1.4.1 Rear of trailers	Table III Trailer rear	S8.2.3.1 Trailer rear.
S5.7.1.4.1 Rear of trailers	Table III Trailer rear—Element 2—White	S8.2.3.1.2 Element 2—white & Exceptions.
S5.7.1.4.1 Rear of trailers	Table III Trailer rear—Element 3—Alternating	S8.2.3.1.3 Element 3—alternating red and white materials & Exceptions.
S5.7.1.4.1(a)	Table III Trailer rear—Element 1—Alternating	S8.2.3.1.1 Element 1—alternating red and white materials.
S5.7.1.4.1(b)	Table III Trailer rear—Element 2—White—requirement.	S8.2.3.1.2.1 Upper corners.
S5.7.1.4.1(b)	Table III Trailer rear—Element 2—White—requirement.	S8.2.3.1.2.2 Non rectangular body.
S5.7.1.4.1(c)	Table III Trailer rear—Element 3—Alternating—requirement.	S8.2.3.1.3.2 Override device.
S5.7.1.4.2 Side of trailers	Table III Trailer side—Alternating	S8.2.3.2 Trailer side—alternating red and white materials.
S5.7.1.4.2(a)	Table III Trailer side—Alternating—requirement.	S8.2.3.2.1 Horizontal strip.
S5.7.1.4.2(a)	Table III Trailer side—Alternating—requirement.	S8.2.3.2.2 Non-continuous.
S5.7.1.4.2(b)	Table III Trailer side—Alternating—requirement.	S8.2.3.2.3 Obstructions.
S5.7.1.4.3 Rear of truck tractors	Table III Truck tractor	S8.2.4 Conspicuity system installation on truck tractors.
S5.7.1.4.3 Rear of truck tractors	Table III Truck tractor—Element 1—Alternating.	S8.2.4.1 Element 1—alternating red and white materials.
S5.7.1.4.3(a)	Table III Truck tractor—Element 1—Alternating—requirement.	S8.2.4.1.1 Lower horizontal.
S5.7.1.4.3(a)	Table III Truck tractor—Element 1—Alternating—requirement.	S8.2.4.1.2 Mudflap mounting.
S5.7.1.4.3(a)	Table III Truck tractor—Element 1—Alternating—requirement.	S8.2.4.1.3 Mounting alternatives.
S5.7.1.4.3(a)	Table III Truck tractor—Element 1—Alternating—requirement.	S8.2.4.1.4 Obstruction.
S5.7.1.4.3(b)	Table III Truck tractor—Element 2—White	S8.2.4.2 Element 2—white.
S5.7.1.4.3(b)	Table III Truck tractor—Element 2—White—requirement.	S8.2.4.2.1 Obstruction.
S5.7.1.4.3(b)	Table III Truck tractor—Element 2—White—requirement.	S8.2.4.2.2 Symmetrical relocation.
S5.7.1.4.3(b)	Table III Truck tractor—Element 2—White—requirement.	S8.2.4.2.3 Window mounting.
S5.7.1.5 Certification	S6.5.1.1 DOT marking—conspicuity sheeting	S6.5.1.1 DOT marking—conspicuity sheeting.
S5.7.1.5 Certification	S7.12.1.1 Certification marking	S8.2.1.3 Certification marking.
S5.7.2 Reflex reflectors	S7.12.2 Conspicuity reflex reflectors	S8.2.2 Conspicuity reflex reflectors.
S5.7.2 Reflex reflectors	S6.8.5.4.1 Reflex reflector and retroreflective sheeting photometry measurements.	S14.2.3.8.1 Reflex reflectors.
S5.7.2.1	S7.12.2.2 Photometry	S8.2.2.3 Photometry.
S5.7.2.1(a)	S6.8.5 Photometric tests	S14.2 Photometric test procedures.
S5.7.2.1(a)	S7.12.2.2 Photometry	S8.2.2.3.1 Red reflectors.

APPENDIX A.—FMVSS NO. 108 REWRITE CROSS REFERENCE—Continued

Current FMVSS No. 108 or incorporated document citation	FMVSS No. 108 rewrite NPRM citation	FMVSS No. 108 rewrite final rule citation
S5.7.2.1(a)	S7.12.2.2 Photometry	S8.2.2.3.2 White reflectors—horizontal orientation.
S5.7.2.1(a)	S7.12.2.2 Photometry	S8.2.2.3.3 White reflectors—vertical orientation.
S5.7.2.1(b)	S7.12.2.2 Photometry	S8.2.2.3.1 Red reflectors.
S5.7.2.1(b)	Table XVI Red conspicuity reflex reflector photometry.	Table XVI—b Red conspicuity reflex reflector photometry.
S5.7.2.1(c)	S7.12.2.2 Photometry	S8.2.2.3.2 White reflectors—horizontal orientation.
S5.7.2.1(c)	Table XVI White horizontal conspicuity reflex reflector photometry.	Table XVI—b White horizontal conspicuity reflex reflector photometry.
S5.7.2.1(d)	S7.12.2.2 Photometry	S8.2.2.3.3 White reflectors—vertical orientation.
S5.7.2.1(d)	Table XVI White vertical conspicuity reflex reflector photometry.	Table XVI—b White vertical conspicuity reflex reflector photometry.
S5.7.2.2	Table III Application pattern	S8.2.2.2 Application pattern.
S5.7.2.2(a)	Table III Application pattern—Alternating—Conspicuity reflex reflectors.	S8.2.2.2.1 Alternating red and white materials.
S5.7.2.2(b)	Table III Application pattern—White—Conspicuity reflex reflectors.	S8.2.2.2.2 White material.
S5.7.2.3 Certification	S7.12.2.1 Certification marking	S8.2.2.1 Certification marking.
S5.7.3 Combination of sheeting and reflectors	S7.12 Conspicuity systems	S8.2 Conspicuity systems.
S5.8 Replacement equipment	S6.7 Replacement equipment	S6.7 Replacement equipment.
S5.8.1	S6.7.1 General requirements	S6.7.1 General requirements.
S5.8.2	S17.3 Sealed beam headlamp markings	S6.5.3.3 Sealed beam headlamp markings.
S5.8.3	S6.7 Replacement equipment	S6.7 Replacement equipment.
S5.8.4	S6.7 Replacement equipment	S6.7 Replacement equipment.
S5.8.5	S6.7 Replacement equipment	S6.7 Replacement equipment.
S5.8.6	S6.7 Replacement equipment	S6.7 Replacement equipment.
S5.8.7	S6.7 Replacement equipment	S6.7 Replacement equipment.
S5.8.8	S6.7 Replacement equipment	S6.7 Replacement equipment.
S5.8.9	S6.7 Replacement equipment	S6.7 Replacement equipment.
S5.8.10	S6.5.1.2 DOT marking—except headlamps	S6.5.1.2 DOT marking—except headlamps.
S5.8.11	S18 Replaceable headlamp lens requirements	S13 Replaceable headlamp lens requirements.
S6 Subreferenced SAE Standards and Recommended Practices.	S5 References to SAE publications	S5 References to SAE publications.
S6.1	S5.1 Recommended=mandatory	S5.1 Recommended=mandatory.
S6.2	S7.1.3 Physical tests	S7.1.1.14 Physical tests.
S6.2	S7.1.3 Physical tests	S7.1.2.14 Physical tests.
S6.2	S7.2.2 Physical tests	S7.2.14 Physical tests.
S6.2	S7.3.2 Physical tests	S7.3.14 Physical tests.
S6.2	S7.4.2 Physical tests	S7.4.14 Physical tests.
S6.2	S7.5.2 Physical tests	S7.5.14 Physical tests.
S6.2	S7.6.3 Physical tests	S7.6.14 Physical tests.
S6.2	S7.7.3 Physical tests	S7.7.14 Physical tests.
S6.2	S7.8.2 Physical tests	S7.8.14 Physical tests.
S6.2	S7.9.4 Physical tests	S7.9.14 Physical tests.
S6.2	S7.9.4 Physical tests	S7.9.14.1 External mount.
S6.2	S7.9.4 Physical tests	S7.9.14.2 Internal mount.
S6.2	S7.10.2 Physical tests	S8.1.12 Physical tests.
S6.2	S7.11.3 Physical tests	S7.10.14 Physical tests.
S6.2	S7.13.2 Physical test requirements	S7.11.14 Physical tests.
S6.3	S4 Definitions—Effective projected luminous lens area.	S4 Definitions—Effective projected luminous lens area.
S7 Headlighting requirements	S8 Headlighting system requirements	S10 Headlighting system requirements.
S7.1	S8.1 Headlighting systems	S10.1.1 Vehicles ex motorcycles & trailers.
S7.2(a)	S6.5.1 DOT marking	S6.5.1 DOT marking.
S7.2(b)	S17.1 Trademark	S6.5.3.1 Trademark.
S7.2(c)	S17.2 Voltage and trade number	S6.5.3.2 Voltage and trade number.
S7.2(d)	S6.8.5.6.2 Aiming	S14.2.5.5 Aiming.
S7.2(d)	S6.8.5.6.5 Location of test points	S14.2.5.2 Glare area.
S7.2(e)	S6.5.1 DOT marking	S6.5.1 DOT marking.
S7.2(e)	S18 Replaceable headlamp lens requirements	S13 Replaceable headlamp lens requirements.
S7.3 Sealed beam headlighting system	S9 Sealed beam headlamp requirements	S10.13 Sealed beam headlighting system.
S7.3	S8.1.1 Headlighting system type	Redundant—eliminated.
S7.3	S8.1.2 Headlamp category	Redundant—eliminated.
S7.3.1	S17.3 Sealed beam headlamp markings	S6.5.3.3 Sealed beam headlamp markings.
S7.3.2 Type A headlighting system	S9.1 Installation	S10.13.1 Installation.
S7.3.2 Type A headlighting system	Table II Sealed beam headlamps Type A	Table II—a Sealed beam headlamps Type A.

APPENDIX A.—FMVSS NO. 108 REWRITE CROSS REFERENCE—Continued

Current FMVSS No. 108 or incorporated document citation	FMVSS No. 108 rewrite NPRM citation	FMVSS No. 108 rewrite final rule citation
S7.3.2(a)(3)	S9.3 Photometry	S10.13.3 Photometry.
S7.3.2(a)(3)	S6.8.5 Photometric tests	S14.2 Photometric test procedures.
S7.3.2(b)	Table XXIII Headlamp connector test	S14.6.15 Headlamp connector test.
S7.3.2(c)	S9.4 Physical tests	S10.13.4.1 Vibration.
S7.3.2(c)	Table XXIII Vibration test—performance requirements.	S14.6.8.3 Performance requirements.
S7.3.2(d)	S9.4 Physical tests	S10.13.4.1 Wattage.
S7.3.2(d)	Table XXIII Headlamp wattage test—performance requirements.	S14.6.16.2 Performance requirements.
S7.3.3 Type B headlighting system	S9.1 Installation	S10.13.1 Installation.
S7.3.3 Type B headlighting system	Table II Sealed beam headlamps Type B	Table II—a Sealed beam headlamps Type B.
S7.3.3(a)	S9.3 Photometry	S10.13.3 Photometry.
S7.3.3(a)	S6.8.5 Photometric tests	S14.2 Photometric test procedures.
S7.3.3(b)	S9.4 Physical tests	S10.13.4.1 Wattage.
S7.3.3(b)	Table XXIII Headlamp wattage test—performance requirements.	S14.6.16.2 Performance requirements.
S7.3.4 Type C headlighting system	S9.1 Installation	S10.13.1 Installation.
S7.3.4 Type C headlighting system	S9.3 Photometry	S10.13.3 Photometry.
S7.3.4 Type C headlighting system	S6.8.5 Photometric tests	S14.2 Photometric test procedures.
S7.3.4 Type C headlighting system	Table II Sealed beam headlamps Type C	Table II—a Sealed beam headlamps Type C.
S7.3.5 Type D headlighting system	S9.1 Installation	S10.13.1 Installation.
S7.3.5 Type D headlighting system	Table II Sealed beam headlamps Type D	Table II—a Sealed beam headlamps Type D.
S7.3.5(a)	S9.3 Photometry	S10.13.3 Photometry.
S7.3.5(a)	S6.8.5 Photometric tests	S14.2 Photometric test procedures.
S7.3.5(b)	S9.4 Physical tests	S10.13.4.1 Wattage.
S7.3.5(b)	Table XXIII Headlamp wattage test—performance requirements.	S14.6.16.2 Performance requirements.
S7.3.6 Type E headlighting system	S9.1 Installation	S10.13.1 Installation.
S7.3.6 Type E headlighting system	Table II Sealed beam headlamps Type E	Table II—a Sealed beam headlamps Type E.
S7.3.6(a)	S9.3 Photometry	S10.13.3 Photometry.
S7.3.6(a)	S6.8.5 Photometric tests	S14.2 Photometric test procedures.
S7.3.6(b)	S9.4 Physical tests	S10.13.4.1 Wattage.
S7.3.6(b)	Table XXIII Headlamp wattage test—performance requirements.	S14.6.16.2 Performance requirements.
S7.3.7 Type F headlighting system	S9.1 Installation	S10.13.1 Installation.
S7.3.7 Type F headlighting system	Table II Sealed beam headlamps Type F	Table II—a Sealed beam headlamps Type F.
S7.3.7(b)	S9.3 Photometry	S10.13.3 Photometry.
S7.3.7(b)	S6.8.5 Photometric tests	S14.2 Photometric test procedures.
S7.3.7(b)	S6.8.5.6.2 Aiming	S14.2.5.5 Aiming.
S7.3.7(d)	S6.8.5 Photometric tests	S14.2 Photometric test procedures.
S7.3.7(e)(1)	S4 Definitions—Mounting ring (type F sealed beam).	S4 Definitions—Mounting ring (type F sealed beam).
S7.3.7(e)(2)	S4 Definitions—Retaining ring (type F sealed beam).	S4 Definitions—Retaining ring (type F sealed beam).
S7.3.7(e)(5)	Table XXIII Aiming adjustment test laboratory—performance requirements.	S14.6.17.2.2 Type F, replaceable bulb, integral beam, and combination.
S7.3.7(e)(7)	Table XXIII Retaining ring test—procedure	S14.6.14.1 Procedure.
S7.3.7(f)	S17.3 Sealed beam headlamp markings	S6.5.3.3 Sealed beam headlamp markings.
S7.3.7(g)	S9.4 Physical tests	S10.13.4.1 Wattage.
S7.3.7(g)	Table XXIII Headlamp wattage test—performance requirements.	S14.6.16.2 Performance requirements.
S7.3.7(h)	S9.2 Simultaneous aim	S10.13.2 Simultaneous aim.
S7.3.7(h)(1)	S9.2 Simultaneous aim	S10.13.2 Simultaneous aim.
S7.3.7(h)(1)	S6.8.5 Photometric tests	S14.2 Photometric test procedures.
S7.3.7(h)(2)	S9.2 Simultaneous aim	S10.13.2 Simultaneous aim.
S7.3.7(i)	S9.4 Physical tests	S10.13.4.1 Vibration.
S7.3.7(i)	Table XXIII Vibration test—performance requirements.	S14.6.8.3 Performance requirements.
S7.3.8 Type G headlighting system	S9.1 Installation	S10.13.1 Installation.
S7.3.8 Type G headlighting system	Table II Sealed beam headlamps Type G	Table II—a Sealed beam headlamps Type G.
S7.3.8(b)	S9.3 Photometry	S10.13.3 Photometry.
S7.3.8(b)	S6.8.5 Photometric tests	S14.2 Photometric test procedures.
S7.3.8(c)(1)	S9.4 Physical tests	S10.13.4.2 Retaining ring test ex types G & H.
S7.3.8(c)(2)	Table XXIII Torque deflection test	S14.6.13 Torque deflection test.
S7.3.8(c)(2)	Table XXIII Torque deflection test—procedure	S14.6.13.1 Procedure.
S7.3.8(c)(2)	Table XXIII Torque deflection test—procedure	S14.6.13.1.1 Mounting.
S7.3.8(c)(2)	Table XXIII Torque deflection test—procedure	S14.6.13.1.2 Deflectometers.
S7.3.8(c)(2)	Table XXIII Torque deflection test—procedure	S14.6.13.1.3 Deflectometer adapters.
S7.3.8(c)(2)	Table XXIII Torque deflection test—procedure	S14.6.13.1.4 Torque.
S7.3.8(d)	S9.4 Physical tests	S10.13.4.1 Vibration.

APPENDIX A.—FMVSS NO. 108 REWRITE CROSS REFERENCE—Continued

Current FMVSS No. 108 or incorporated document citation	FMVSS No. 108 rewrite NPRM citation	FMVSS No. 108 rewrite final rule citation
S7.3.8(d)	Table XXIII Vibration test—performance requirements.	S14.6.8.3 Performance requirements.
S7.3.8(e)	S9.4 Physical tests	S10.13.4.1 Wattage.
S7.3.8(e)	Table XXIII Headlamp wattage test—performance requirements.	S14.6.16.2 Performance requirements.
S7.3.8(f)	S17.3 Sealed beam headlamp markings	S6.5.3.3 Sealed beam headlamp markings.
S7.3.9 Type H headlighting system	S9.1 Installation	S10.13.1 Installation.
S7.3.9 Type H headlighting system	Table II Sealed beam headlamps Type H	Table II—a Sealed beam headlamps Type H.
S7.3.9(a)	S9.3 Photometry	S10.13.3 Photometry.
S7.3.9(a)	S6.8.5 Photometric tests	S14.2 Photometric test procedures.
S7.3.9(b)	S9.4 Physical tests	S10.13.4.1 Wattage.
S7.3.9(b)	Table XXIII Headlamp wattage test—performance requirements.	S14.6.16.2 Performance requirements.
S7.3.9(c)	S17.3 Sealed beam headlamp markings	S6.5.3.3 Sealed beam headlamp markings.
S7.4 Integral Beam Headlighting System	S10 Integral beam headlamp requirements	S10.14 Integral beam headlighting.
S7.4 Integral Beam Headlighting System	S10.1 Installation	S10.14.1 Installation.
S7.4 Integral Beam Headlighting System	S8.1.1 Headlighting system type	Redundant—eliminated.
S7.4 Integral Beam Headlighting System	S8.1.2 Headlamp category	Redundant—eliminated.
S7.4(a)	S10.1 Installation	S10.14.1 Installation.
S7.4(a)	S10.6 Photometry	S10.14.6 Photometry.
S7.4(a)(1)(i)	S6.8.5 Photometric tests	S14.2 Photometric test procedures.
S7.4(a)(1)(i)	Table II Integral beam headlamps—4 lamp system.	Table II—c Integral beam headlamps—4 lamp system.
S7.4(a)(1)(ii)	S8.2 Simultaneous beam activation	S6.1.5.2.3.
S7.4(a)(1)(ii)	S6.8.5 Photometric tests	S14.2 Photometric test procedures.
S7.4(a)(1)(ii)	Table II Integral beam headlamps—4 lamp system—simultaneous activation.	Table II—c Integral beam headlamps—4 lamp system—simultaneous activation.
S7.4(a)(1)(ii)	Table XVIII Upper beam #6 photometry	Table XVIII Upper beam #6 photometry.
S7.4(a)(1)(ii)	Table XIX Lower beam #5M photometry	Table XIX—b Lower beam #5M photometry.
S7.4(a)(1)(ii)	Table XIX Lower beam #4V photometry	Table XIX—c Lower beam #4V photometry.
S7.4(a)(1)(iii)	S6.8.5 Photometric tests	S14.2 Photometric test procedures.
S7.4(a)(1)(iii)	Table II Integral beam headlamps—4 lamp system U & L.	Table II—c Integral beam headlamps—4 lamp system U & L.
S7.4(a)(2)	Table II Integral beam headlamps—2 lamp system.	Table II—c Integral beam headlamps—2 lamp system.
S7.4(a)(2)(i)	S6.8.5 Photometric tests	S14.2 Photometric test procedures.
S7.4(a)(2)(ii)	S6.8.5 Photometric tests	S14.2 Photometric test procedures.
S7.4(a)(3)	S6.8.5 Photometric tests	S14.2 Photometric test procedures.
S7.4(a)(3)	S6.8.5.6.6 Beam contributor photometry	S14.2.5.9 Beam contributor photometry measurements.
S7.4(a)(3)	Table II Integral beam headlamps—beam contributor system.	Table II—c Integral beam headlamps—beam contributor system.
S7.4(a)(3)	Table II footnote 6	Table II footnote 6.
S7.4(a)(3)	Omitted	Table II footnote 7.
S7.4(b)	S8.1.3 Vertical headlamp arrangement	S6.1.3.5.1 Vertical headlamp arrangement.
S7.4(b)	S8.1.4 Horizontal headlamp arrangement	S6.1.3.5.2 Horizontal headlamp arrangement.
S7.4(c)(1)	S10.4 Markings	S10.14.4 Markings.
S7.4(c)(2)	S10.4 Markings	S10.14.4 Markings.
S7.4(d)	S10.3 Simultaneous aim	S10.14.3 Simultaneous aim.
S7.4(d)	Table II footnote 2	Table II footnote 2.
S7.4(e)	S6.8.5.6 Headlamp photometry measurements.	S14.2.5.3 Measurement distance.
S7.4(f)	S10.2 Aimability	S10.14.2 Aimability.
S7.4(g)	S10.7 Physical tests	S10.14.7.1 Corrosion test.
S7.4(g)	S10.7 Physical tests	S10.14.7.2 Sealing test.
S7.4(g)	S10.7 Physical tests	S10.14.7.2 Dust test.
S7.4(g)	S10.7 Physical tests	S10.14.7.2 Humidity test.
S7.4(g)	S10.7 Physical tests	S10.14.7.3 Abrasion test.
S7.4(g)	S10.7 Physical tests	S10.14.7.4 Chemical resistance test.
S7.4(g)	S10.7 Physical tests	S10.14.7.5 Internal heat test.
S7.4(g)	S11.7 Physical tests	S10.15.7.1 Corrosion test.
S7.4(g)	S11.7 Physical tests	S10.15.7.1 Dust test.
S7.4(g)	S11.7 Physical tests	S10.15.7.1 Humidity test.
S7.4(g)	S11.7 Physical tests	S10.15.7.2 Abrasion test.
S7.4(g)	S11.7 Physical tests	S10.15.7.3 Chemical resistance test.
S7.4(g)	S11.7 Physical tests	S10.15.7.4 Internal heat test.
S7.4(g)	Table XXIII Sealing test—performance requirements.	S14.6.9.2 Performance requirements.
S7.4(h)(1)	S10.7 Physical tests	S10.14.7.3 Abrasion test.
S7.4(h)(1)	S11.7 Physical tests	S10.15.7.2 Abrasion test.

APPENDIX A.—FMVSS NO. 108 REWRITE CROSS REFERENCE—Continued

Current FMVSS No. 108 or incorporated document citation	FMVSS No. 108 rewrite NPRM citation	FMVSS No. 108 rewrite final rule citation
S7.4(h)(1); S8.1	Table XXIII Abrasion test—performance requirements.	S14.6.1.2 Performance requirements.
S7.4(h)(2)	S10.7 Physical tests	S10.14.7.6 Chemical resistance—reflector.
S7.4(h)(2)	S11.7 Physical tests	S10.15.7.5 Chemical resistance—reflector.
S7.4(h)(2)	S10.7 Physical tests	S10.14.7.4 Chemical resistance test.
S7.4(h)(2)	S11.7 Physical tests	S10.15.7.3 Chemical resistance test.
S7.4(h)(2); S8.1	Table XXIII Chemical resistance test—performance requirements.	S14.6.2.2 Performance requirements.
S7.4(h)(2); S8.1	Table XXIII Chemical resistance of reflectors of replaceable lens headlamps test—performance requirements.	S14.6.10.2 Performance requirements.
S7.4(h)(3)	S10.7 Physical tests	S10.14.7.6 Corrosion resistance—reflector.
S7.4(h)(3)	S11.7 Physical tests	S10.15.7.5 Corrosion resistance—reflector.
S7.4(h)(3)	Table XXIII Corrosion-connector test—performance requirements.	S14.6.4.2 Performance requirements.
S7.4(h)(3)	Table XXIII Corrosion-connector test—performance requirements.	S14.6.4.2.1 Corrosion.
S7.4(h)(3)	Table XXIII Corrosion-connector test—performance requirements.	S14.6.4.2.2 Adhesion.
S7.4(h)(3)	Table XXIII Corrosion-connector test—performance requirements.	S14.6.4.2.3 Terminal corrosion.
S7.4(h)(3)	S10.7 Physical tests	S10.14.7.1 Corrosion test.
S7.4(h)(3)	S11.7 Physical tests	S10.15.7.1 Corrosion test.
S7.4(h)(3); S8.1	Table XXIII Corrosion resistance of reflectors of replaceable lens headlamps test—performance requirements.	S14.6.11.2 Performance requirements.
S7.4(h)(4)	S10.7 Physical tests	S10.14.7.2 Dust test.
S7.4(h)(4)	S11.7 Physical tests	S10.15.7.1 Dust test.
S7.4(h)(4); S8.1	Table XXIII Dust test—performance requirements.	S14.6.5.2 Performance requirements.
S7.4(h)(5)(i)	S10.7 Physical tests	S10.14.7.1 Temperature cycle test.
S7.4(h)(5)(i)	S11.7 Physical tests	S10.15.7.1 Temperature cycle test.
S7.4(h)(5)(i); S8.1	Table XXIII Temperature cycle test—performance requirements.	S14.6.6.3.2 Performance requirements.
S7.4(h)(5)(ii)	S10.7 Physical tests	S10.14.7.5 Internal heat test.
S7.4(h)(5)(ii)	S11.7 Physical tests	S10.15.7.4 Internal heat test.
S7.4(h)(5)(ii); S8.1	Table XXIII Internal heat test—performance requirements.	S14.6.6.4.2 Performance requirements.
S7.4(h)(6)	Table XXIII Humidity test—performance requirements.	S14.6.7.2 Performance requirements.
S7.4(h)(6)	S10.7 Physical tests	S10.14.7.2 Humidity test.
S7.4(h)(6)	S11.7 Physical tests	S10.15.7.1 Humidity test.
S7.4(h)(7)	S10.7 Physical tests	S10.14.7.1 Vibration test.
S7.4(h)(7)	S11.7 Physical tests	S10.15.7.1 Vibration test.
S7.4(h)(7)	Table XXIII Vibration test—performance requirements.	S14.6.8.3 Performance requirements.
S7.4(i)	S10.5 Additional light sources	S10.14.5 Additional light sources.
S7.5 Replaceable bulb headlighting system	S11 Replaceable bulb headlamp requirements	S10.15 Replaceable bulb headlighting system.
S7.5 Replaceable bulb headlighting system	S8.1.1 Headlighting system type	Redundant—eliminated.
S7.5 Replaceable bulb headlighting system	S8.1.2 Headlamp category	Redundant—eliminated.
S7.5(a)	S11.1 Installation	S10.15.1 Installation.
S7.5(b)	S11.6 Photometry	S10.15.6 Photometry.
S7.5(b)	S6.8.5 Photometric tests	S14.2 Photometric test procedures.
S7.5(c)	S6.8.5.6 Headlamp photometry measurements.	S14.2.5.3 Measurement distance.
S7.5(d)	S8.1.3 Vertical headlamp arrangement	S6.1.3.5.1 Vertical headlamp arrangement.
S7.5(d)	S8.1.4 Horizontal headlamp arrangement	S6.1.3.5.2 Horizontal headlamp arrangement.
S7.5(d)	Table II Replaceable bulb headlamps—2 lamp system—without HB2.	Table II—d Replaceable bulb headlamps—2 lamp system—without HB2.
S7.5(d)	Table II Replaceable bulb headlamps—4 lamp system—without HB2.	Table II—d Replaceable bulb headlamps—4 lamp system—without HB2.
S7.5(d)(1)	S11.2 Aiming restrictions	S10.15.2 Aiming restrictions.
S7.5(d)(2)	S6.8.5 Photometric tests	S14.2 Photometric test procedures.
S7.5(d)(3)(i)(A)	Omitted	S10.15.4.1.1 Exception.
S7.5(d)(3)(i)(B)	S11.5 Markings	S10.15.4.1 U & L.
S7.5(d)(3)(ii)(A)	Omitted	S10.15.4.1.1 Exception.
S7.5(d)(3)(ii)(B)	S11.5 Markings	S10.15.4.1 U & L.
S7.5(e)	Table II Replaceable bulb headlamps—2 lamp system—with HB2.	Table II—d Replaceable bulb headlamps—2 lamp system—with HB2.
S7.5(e)	Table II Replaceable bulb headlamps—4 lamp system—with HB2.	Table II—d Replaceable bulb headlamps—4 lamp system—with HB2.

APPENDIX A.—FMVSS NO. 108 REWRITE CROSS REFERENCE—Continued

Current FMVSS No. 108 or incorporated document citation	FMVSS No. 108 rewrite NPRM citation	FMVSS No. 108 rewrite final rule citation
S7.5(e)(1)	S11.2 Aiming restrictions	S10.15.2 Aiming restrictions.
S7.5(e)(2)	S6.8.5 Photometric tests	S14.2 Photometric test procedures.
S7.5(e)(3)(i)	S11.5 Markings	S10.15.4.1 U & L.
S7.5(e)(3)(ii)	S11.5 Markings	S10.15.4.1 U & L.
S7.5(f)	S11.4 Replacement equipment	S10.15.3 Replacement equipment.
S7.5(g)	S17.4 Replaceable bulb headlamp markings ..	S6.5.3.4 Replaceable bulb headlamp markings.
S7.5(h)	S11.2 Aiming restrictions	S10.15.2 Aiming restrictions.
S7.5(i)	S11.7 Physical tests	S10.15.7 Physical tests.
S7.5(i)	Table XXIII Sealing test—performance requirements.	S14.6.9.2 Performance requirements.
S7.5(j)	S11.3 Additional light sources	S10.15.5. Additional light sources.
S7.6 Combination Headlighting System	S12 Combination headlamps	S10.16 Combination headlighting system.
S7.6 Combination Headlighting System	S8.1.1 Headlighting system type	Redundant—eliminated.
S7.6 Combination Headlighting System	S8.1.2 Headlamp category	Redundant—eliminated.
S7.6.1	S12.1 Installation	S10.16.1 Installation.
S7.6.2	S12.2 Photometry	S10.16.2 Photometry.
S7.6.2	S12.3 Physical tests	S10.16.3.1 Type F sealed beam.
S7.6.2	S6.8.5 Photometric tests	S14.2 Photometric test procedures.
S7.6.2	Table II Combination headlamps—2 lamp system.	Table II—b Combination headlamps—2 lamp system.
S7.6.2.1	S12.2 Photometry	S10.16.2 Photometry.
S7.6.2.1	S12.3 Physical tests	S10.16.3.2 Integral beam.
S7.6.2.2	S12.2 Photometry	S10.16.2 Photometry.
S7.6.2.2	S12.3 Physical tests	S10.16.3.3 Replaceable bulb.
S7.6.3	S12.2 Photometry	S10.16.2 Photometry.
S7.6.3	S6.8.5 Photometric tests	S14.2 Photometric test procedures.
S7.6.3	Table II Combination headlamps—4 lamp system.	Table II—b Combination headlamps—4 lamp system.
S7.7 Replaceable light sources	S15 Replaceable light sources	S11 Replaceable light sources.
S7.7(a)	S15.1 Markings	S11.1 Markings.
S7.7(b)	S15.2 Power and flux measurement	S11.4.2 Power & Luminous flux tests.
S7.7(b)	S15.2; S15.3	S14.7.3 Replaceable light source power and flux measurement procedure.
S7.7(b)	S15.2; S15.3	S14.7.3.1 Seasoning.
S7.7(b)	S15.2; S15.3	S14.7.3.1.1 Resistive filament source.
S7.7(b)	S15.2; S15.3	S14.7.3.1.2 Discharge source.
S7.7(b)	S15.2; S15.3	S14.7.3.2 Test voltage.
S7.7(b)	S15.2; S15.3	S14.7.3.3 Luminous flux measurement.
S7.7(b)	S15.2; S15.3	S14.7.3.3.1 Resistive filament light source setup.
S7.7(b)	S15.2; S15.3	S14.7.3.3.2 Discharge light source setup.
S7.7(c)	S15.6 Physical tests	S11.4.1 Pressure test.
S7.7(c)	Table XXIII Pressure test for replaceable light sources.	S14.7.2 Pressure test for replaceable light sources.
S7.7(c)	Table XXIII Pressure test for replaceable light sources—procedure.	S14.7.2.1 Procedure.
S7.7(c)	Table XXIII Pressure test for replaceable light sources—procedure.	S14.7.2.1.1 Force application.
S7.7(c)	Table XXIII Pressure test for replaceable light sources—procedure.	S14.7.2.1.2 Application sequence.
S7.7(c)	Table XXIII Pressure test for replaceable light sources—performance requirements.	S14.7.2.2 Performance requirements.
S7.7(d)	S15.2; S15.3	S14.7.3 Replaceable light source power and flux measurement procedure.
S7.7(d)	S15.2; S15.3	S14.7.3.1 Seasoning.
S7.7(d)	S15.2; S15.3	S14.7.3.1.1 Resistive filament source.
S7.7(d)	S15.2; S15.3	S14.7.3.1.2 Discharge source.
S7.7(d)	S15.2; S15.3	S14.7.3.2 Test voltage.
S7.7(d)	S15.2; S15.3	S14.7.3.3 Luminous flux measurement.
S7.7(d)	S15.2; S15.3	S14.7.3.3.1 Resistive filament light source setup.
S7.7(d)	S15.2; S15.3	S14.7.3.3.2 Discharge light source setup.
S7.7(d)	S15.3 Power and flux measurement	S11.4.2 Power & Luminous flux tests.
S7.7(e)	S15.4 Ballast markings	S11.2 Ballast markings.
S7.7(f)	S15.5 Gas discharge laboratory life	S11.3 Gas discharge laboratory life.
S7.7(g)	S15.6 Physical tests	S11.4.1 Deflection test.
S7.7(g)	Table XXIII Deflection test for replaceable light sources—performance requirements.	S14.7.1.2 Performance requirements.
S7.8 Aimability Performance Requirements	Table XXIII Aiming adjustment test laboratory	S14.6.17 Aiming adjustment test—laboratory.
S7.8 Aimability Performance Requirements	Table XXIII Aiming adjustment test on vehicle	S14.6.18 Aiming adjustment test—on vehicle.

APPENDIX A.—FMVSS NO. 108 REWRITE CROSS REFERENCE—Continued

Current FMVSS No. 108 or incorporated document citation	FMVSS No. 108 rewrite NPRM citation	FMVSS No. 108 rewrite final rule citation
S7.8 Aimability Performance Requirements	Table XXIII Aiming adjustment test on vehicle—performance requirements.	S14.6.18.2 Performance requirements.
S7.8.1	S14.6 Optical axis marking	S10.18.5 Optical axis marking.
S7.8.1(a)	S14.6.2 Optical axis marking—lamp	S10.18.5.2 Optical axis marking—lamp.
S7.8.1(b)	S14.6.1 Optical axis marking—vehicle	S10.18.5.1 Optical axis marking—vehicle.
S7.8.1(c)	S14.6.3 Optical axis marking—visual aim headlamp.	S10.18.5.3 Optical axis marking—visual aim headlamp.
S7.8.2	S14.1 Headlamp mounting and aiming	S10.18.1 Headlamp mounting and aiming.
S7.8.2.1(a)	S14.4 Aim adjustment interaction	S10.18.3 Aim adjustment interaction.
S7.8.2.1(a)	Table XXIII Aiming adjustment test on vehicle—performance requirements.	S14.6.18.2.3 Aim interaction.
S7.8.2.1(b)	S14.4 Aim adjustment interaction	S10.18.3 Aim adjustment interaction.
S7.8.2.1(c)	S14.5 Horizontal adjustment—visually aimed headlamp.	S10.18.4 Horizontal adjustment—visually aimed headlamp.
S7.8.2.1(c)	Table XXIII Aiming adjustment test on vehicle—performance requirements.	S14.6.18.2.3 Aim interaction.
S7.8.2.1(c)	Table XXIII Aiming adjustment test laboratory—performance requirements.	S14.6.17.2 Performance requirements.
S7.8.2.2(a)	S14.7 Moveable reflectors	S10.18.6 Moveable reflector requirements.
S7.8.2.2(a)	Table XXIII Aiming adjustment test laboratory—performance requirements.	S14.6.17.2.3 Moveable reflector.
S7.8.2.2(b)	S14.7 Moveable reflectors	S10.18.6 Moveable reflector requirements.
S7.8.2.2(b)	S6.8.5.6.2(h) Aiming—Moveable reflector	S14.2.5.10.1.
S7.8.2.2(c)	Table XXIII Aiming adjustment test laboratory—performance requirements.	S14.6.17.2.3 Moveable reflector.
S7.8.2.2(d)	Table XXIII Aiming adjustment test laboratory—performance requirements.	S14.6.17.2 Performance requirements.
S7.8.3	S6.8.5.6.2(h) Aiming—Moveable reflector	S14.2.5.10.2.
S7.8.3	Table XXIII Aiming adjustment test on vehicle—procedure.	S14.6.18.1.2 Vehicle pitch.
S7.8.3	Table XXIII Aiming adjustment test on vehicle—performance requirements.	S14.6.18.2.1 Vertical range.
S7.8.3	Table XXIII Aiming adjustment test on vehicle—performance requirements.	S14.6.18.2.2 Continuous vertical adjustment.
S7.8.3	Table XXIII Aiming adjustment test laboratory—performance requirements.	S14.6.17.2.1 Sealed beam except Type F.
S7.8.3	Table XXIII Aiming adjustment test laboratory—performance requirements.	S14.6.17.2.2 Type F, replaceable bulb, integral beam, and combination.
S7.8.4	S6.8.5.6.2(h) Aiming—Moveable reflector	S14.2.5.10.3.
S7.8.4	Table XXIII Aiming adjustment test laboratory—performance requirements.	S14.6.17.2.1 Sealed beam except Type F.
S7.8.4	Table XXIII Aiming adjustment test laboratory—performance requirements.	S14.6.17.2.2 Type F, replaceable bulb, integral beam, and combination.
S7.8.5	S14.2 Headlamp obstructions	S6.2.3 Headlamp Obstructions.
S7.8.5	S14.2 Headlamp obstructions	S6.2.3.1 Coverings.
S7.8.5	S14.2 Headlamp obstructions	S6.2.3.2 Wipers.
S7.8.5	S10.2 Aimability	S10.2 Aiming.
S7.8.5	S14.3 Headlamp aiming systems	S10.18.2 Headlamp aiming systems.
S7.8.5.1 External aiming	S14.8 External aiming	S10.18.7 External aiming.
S7.8.5.1(a)	S10.7 Physical tests	S10.14.7.7 Torque deflection test.
S7.8.5.1(a)	S11.7 Physical tests	S10.15.7.6 Torque deflection test.
S7.8.5.1(a)	Table XXIII Torque deflection test	S14.6.13 Torque deflection test.
S7.8.5.1(a)	Table XXIII Torque deflection test—procedure	S14.6.13.1 Procedure.
S7.8.5.1(a)	Table XXIII Torque deflection test—procedure	S14.6.13.1.1 Mounting.
S7.8.5.1(a)	Table XXIII Torque deflection test—procedure	S14.6.13.1.2 Deflectometers.
S7.8.5.1(a)	Table XXIII Torque deflection test—procedure	S14.6.13.1.3 Deflectometer adapters.
S7.8.5.1(a)	Table XXIII Torque deflection test—procedure	S14.6.13.1.4 Torque.
S7.8.5.1(a)	Table XXIII Torque deflection test—procedure	S14.6.13.1.5 Torque application.
S7.8.5.1(a)	Table XXIII Torque deflection test—procedure	S14.6.13.1.6 Group I aiming pads.
S7.8.5.1(a)	Table XXIII Torque deflection test—procedure	S14.6.13.1.7 Group II aiming pads.
S7.8.5.1(a)	Table XXIII Torque deflection test—procedure	S14.6.13.1.8 Non-adjustable locating plates.
S7.8.5.1(a)	Table XXIII Torque deflection test—performance requirements.	S14.6.13.2 Performance requirements.
S7.8.5.1(b)	Table XXIII Inward force test	S14.6.12 Inward force test.
S7.8.5.1(b)	S10.7 Physical tests	S10.14.7.1 Inward force test.
S7.8.5.1(b)	S11.7 Physical tests	S10.15.7.1 Inward force test.
S7.8.5.1(b)	Table XXIII Inward force test—performance requirements.	S14.6.12.2 Performance requirements.
S7.8.5.1(c)	Table XXIII Corrosion test—procedure	S14.6.3.1 Procedure.
S7.8.5.1(c)	Table XXIII VHAD corrosion test—procedure	S14.8.6.1 Procedure.

APPENDIX A.—FMVSS NO. 108 REWRITE CROSS REFERENCE—Continued

Current FMVSS No. 108 or incorporated document citation	FMVSS No. 108 rewrite NPRM citation	FMVSS No. 108 rewrite final rule citation
S7.8.5.1(c)	Table XXIII Corrosion test—performance requirements.	S14.6.3.2 Performance requirements.
S7.8.5.1(c)	Table XXIII VHAD corrosion test—performance requirements.	S14.8.6.2 Performance requirements.
S7.8.5.1(d)	S14.8.1 Headlamp aiming device locating plates.	S10.18.7.1 Headlamp aiming device locating plates.
S7.8.5.1(d)(1)	S14.8.1.1 Aiming pads	S10.18.7.1.1 Aiming pads.
S7.8.5.1(d)(2)	S14.8.1.2 Aiming dimension marking	S10.18.7.1.2 Aiming dimension marking.
S7.8.5.1(e)	S14.8.2 Nonadjustable headlamp aiming device locating plates.	S10.18.7.2 Nonadjustable headlamp aiming device locating plates.
S7.8.5.2 On-vehicle aiming	S14.9 On-vehicle aiming	S10.18.8 On-vehicle aiming.
S7.8.5.2(a) Aim	S14.9.1 Aim	S10.18.8.1 Aim.
S7.8.5.2(a)(1) Vertical axis	S14.9.1.1 Vertical aim	S10.18.8.1.1 Vertical aim.
S7.8.5.2(a)(1)(i)	S14.9.1.1.1 Graduations	S10.18.8.1.1.1 Graduations.
S7.8.5.2(a)(1)(ii)	S14.9.1.1.2 VHAD markings	S10.18.8.1.1.2 VHAD markings.
S7.8.5.2(a)(1)(iii)	S14.9.1.1.3 Graduation scale	S10.18.8.1.1.3 Graduation scale.
S7.8.5.2(a)(1)(iv)	S14.9.1.1.4 Vertical indicator range	S10.18.8.1.1.4 Vertical indicator range.
S7.8.5.2(a)(1)(v)	S14.9.1.1.5 Floor slope compensation	S10.18.8.1.1.5 Floor slope compensation.
S7.8.5.2(a)(1)(vi)	S14.9.1.1.6 Graduation legibility	S10.18.8.1.1.6 Graduation legibility.
S7.8.5.2(a)(2) Horizontal aim	S14.9.1.2 Horizontal aim	S10.18.8.1.2 Horizontal aim.
S7.8.5.2(a)(2)(i)	S14.9.1.2.1 Graduation scale	S10.18.8.1.2.1 Graduation scale.
S7.8.5.2(a)(2)(ii)	S14.9.1.2.2 Horizontal markings	S10.18.8.1.2.2 Horizontal markings.
S7.8.5.2(a)(2)(iii)	S14.9.1.2.3 Graduation legibility	S10.18.8.1.2.3 Graduation legibility.
S7.8.5.2(a)(2)(iv)	S14.9.1.2.4 Horizontal indicator range	S10.18.8.1.2.4 Horizontal indicator range.
S7.8.5.2(b) Aiming instructions	S14.9.2 Aiming instructions	S10.18.8.2 Aiming instructions.
S7.8.5.2(b)(1)	S14.9.2.1 Aiming instruction location and content.	S10.18.8.2.1 Aiming instruction location and content.
S7.8.5.2(b)(2)	S14.9.2.2 Remote indicator instructions	S10.18.8.2.2 Remote indicator instructions.
S7.8.5.2(b)(3)	S14.4.1 Excess aim interaction	S10.18.3.1 Excess aim interaction.
S7.8.5.2(c)	S14.9.3 Permanent calibrations	S10.18.8.3 Permanent calibration.
S7.8.5.2(d) Testing the VHAD	S14.9.5 Physical tests	S10.18.8.5 Physical tests.
S7.8.5.2(d)(1)	S6.8.5.6 Headlamp photometry measurements.	S14.2.5.3 Measurement distance.
S7.8.5.2(d)(1)	S6.8.5.6.2 Aiming	S14.2.5.5 Aiming.
S7.8.5.2(d)(1)	S6.8.5.6.2(b) Aiming—VHAD	S14.2.5.5.2 Mechanically aimable headlamps equipped with a VHAD.
S7.8.5.2(d)(2)	S14.9.4 Replacement units	S10.18.8.4 Replacement units.
S7.8.5.2(d)(3)(i)	Table XXIII VHAD scale graduation test	S14.8.2 Scale graduation test.
S7.8.5.2(d)(3)(i)	Table XXIII VHAD scale graduation test—procedure.	S14.8.2.1 Procedure.
S7.8.5.2(d)(3)(i)	Table XXIII VHAD scale graduation test—performance requirements.	S14.8.2.2 Performance requirements.
S7.8.5.2(d)(3)(ii)	Table XXIII	S14.8.1 Samples.
S7.8.5.2(d)(3)(ii)(A)	Table XXIII VHAD cold scale graduation test ..	S14.8.3 Cold scale graduation test.
S7.8.5.2(d)(3)(ii)(A)	Table XXIII VHAD cold scale graduation test—procedure.	S14.8.3.1 Procedure.
S7.8.5.2(d)(3)(ii)(A)	Table XXIII VHAD cold scale graduation test—performance requirements.	S14.8.3.2 Performance requirements.
S7.8.5.2(d)(3)(ii)(B)	Table XXIII VHAD hot scale graduation test ...	S14.8.4 Hot scale graduation test.
S7.8.5.2(d)(3)(ii)(B)	Table XXIII VHAD hot scale graduation test—procedure.	S14.8.4.1 Procedure.
S7.8.5.2(d)(3)(ii)(B)	Table XXIII VHAD hot scale graduation test—performance requirements.	S14.8.4.2 Performance requirements.
S7.8.5.2(d)(3)(ii)(C)	Table XXIII VHAD thermal cycle test	S14.8.5 Thermal cycle test.
S7.8.5.2(d)(3)(ii)(C)	Table XXIII VHAD thermal cycle test—procedure.	S14.8.5.1 Procedure.
S7.8.5.2(d)(3)(ii)(C)	Table XXIII VHAD thermal cycle test—performance requirements.	S14.8.5.2 Performance requirements.
S7.8.5.2(d)(3)(ii)(D)	Table XXIII VHAD corrosion test	S14.8.6 Corrosion test.
S7.8.5.2(d)(3)(ii)(E)	Table XXIII VHAD photometry test	S14.8.7 Photometry test.
S7.8.5.2(d)(3)(ii)(E)	Table XXIII VHAD photometry test—procedure.	S14.8.7.1 Procedure.
S7.8.5.2(d)(3)(ii)(E)	Table XXIII VHAD photometry test—performance requirements.	S14.8.7.2 Performance requirements.
S7.8.5.3 Visual/optical aiming	S14.10 Visual/optical aiming	S10.18.9 Visual/optical aiming.
S7.8.5.3(a) Vertical aim, lower beam	S14.10.1 Vertical aim, lower beam	S10.18.9.1 Vertical aim, lower beam.
S7.8.5.3(a)(1) Vertical position of cutoff	S14.10.1.1 Vertical position of the cutoff	S10.18.9.1.1 Vertical position of the cutoff.
S7.8.5.3(a)(1) Vertical position of cutoff	S6.8.5.6.2(c) Aiming—LB VOL/VOR vertical ...	S14.2.5.5.3.1 VOL.
S7.8.5.3(a)(1) Vertical position of cutoff	S6.8.5.6.2(c) Aiming—LB VOL/VOR vertical ...	S14.2.5.5.3.2 VOL.
S7.8.5.3(a)(2) Vertical gradient	S14.10.1.2 Vertical gradient	S10.18.9.1.2 Vertical gradient.
S7.8.5.3(a)(3) Horizontal position of the cutoff ..	S14.10.1.3 Horizontal position of the cutoff	S10.18.9.1.3 Horizontal position of the cutoff.

APPENDIX A.—FMVSS NO. 108 REWRITE CROSS REFERENCE—Continued

Current FMVSS No. 108 or incorporated document citation	FMVSS No. 108 rewrite NPRM citation	FMVSS No. 108 rewrite final rule citation
S7.8.5.3(a)(4) Maximum inclination of cutoff	S14.10.1.4 Maximum inclination of the cutoff ..	S10.18.9.1.4 Maximum inclination of the cutoff.
S7.8.5.3(a)(5)(i)	S14.10.1.5 Measuring the cutoff parameter	S10.18.9.1.5 Measuring the cutoff parameter.
S7.8.5.3(a)(5)(i)	S14.10.1.5.1 Test position	S10.18.9.1.5.1 Test position.
S7.8.5.3(a)(5)(ii)	S14.10.1.5.2 Headlamp aiming	S10.18.9.1.5.2 Headlamp aiming.
S7.8.5.3(a)(5)(iii)	S14.10.1.5.3 Beam scanning	S10.18.9.1.5.3 Beam scanning.
S7.8.5.3(a)(5)(iv)	S14.10.1.5.4 Gradient calculation	S10.18.9.1.5.4 Gradient calculation.
S7.8.5.3(b) Horizontal aim, lower beam	S14.10.2 Horizontal aim, lower beam	S10.18.9.2 Horizontal aim, lower beam.
S7.8.5.3(b) Horizontal aim, lower beam	S6.8.5.6.2(d) Aiming—LB VOL/VOR horizontal	S14.2.5.5.4 Visually aimable lower beam headlamps—horizontal aim.
S7.8.5.3(c) Vertical aim, upper beam	S14.10.3 Vertical aim, upper beam	S10.18.9.3 Vertical aim, upper beam.
S7.8.5.3(c)(1)	S14.10.3.1 Combined upper and lower beams	S10.18.9.3.1 Combined upper and lower beams.
S7.8.5.3(c)(1)	S6.8.5.6.2(e) Aiming—UB VOL/VOR vertical ..	S14.2.5.5.5.1 Combined UB & LB.
S7.8.5.3(c)(2)	S14.10.3.2 Upper beam without lower beam ..	S10.18.9.3.2 Upper beam without lower beam.
S7.8.5.3(c)(2)	S6.8.5.6.2(e) Aiming—UB VOL/VOR vertical ..	S14.2.5.5.5.2 Non-combined UB & LB.
S7.8.5.3(d) Horizontal aim, upper beam	S14.10.4 Horizontal aim, upper beam	S10.18.9.4 Horizontal aim, upper beam.
S7.8.5.3(d)(1)	S6.8.5.6.2(f) Aiming—UB VOL/VOR horizontal	S14.2.5.5.6.1 Combined UB & LB.
S7.8.5.3(d)(1)	S14.10.4.1 Combined upper and lower beams	S10.18.9.4.1 Combined upper and lower beams.
S7.8.5.3(d)(2)	S6.8.5.6.2(f) Aiming—UB VOL/VOR horizontal	S14.2.5.5.6.2 Non-combined UB & LB with VHAD.
S7.8.5.3(d)(2)	S14.10.4.2 Upper beam without lower beam ..	S10.18.9.4.2 Upper beam without lower beam.
S7.8.5.3(d)(3)	S6.8.5.6.2(f) Aiming—UB VOL/VOR horizontal	S14.2.5.5.6.3 Non-combined UB & LB without VHAD.
S7.8.5.3(d)(3)	S14.10.4.3 Upper beam without lower beam of VHAD.	S10.18.9.4.3 Upper beam without lower beam of VHAD.
S7.8.5.3(e)(1)	S14.10.5 Photometric measurements	S10.18.9.5 Photometry.
S7.8.5.3(e)(2)	S6.8.5.6.2 Aiming	S14.2.5.5 Aiming.
S7.8.5.3(e)(2)	S6.8.5.6.2(c) Aiming—LB VOL/VOR vertical ...	S14.2.5.5.3.1 VOL.
S7.8.5.3(e)(2)	S6.8.5.6.2(c) Aiming—LB VOL/VOR vertical ...	S14.2.5.5.3.2 VOR.
S7.8.5.3(e)(2)	S6.8.5.6.2(e) Aiming—UB VOL/VOR vertical ...	S14.2.5.5.5.1 Combined UB & LB.
S7.8.5.3(e)(2)	S6.8.5.6.2(e) Aiming—UB VOL/VOR vertical ..	S14.2.5.5.5.2 Non-combined UB & LB.
S7.8.5.3(f)(1)	S14.6.3 Optical axis marking—visual aim headlamp.	S10.18.5.3 Optical axis marking—visual aim headlamp.
S7.8.5.3(f)(2)(i)	S14.10.6.1 VOL/VOR/VO markings	S10.18.9.6.1 VOL/VOR/VO markings.
S7.8.5.3(f)(2)(ii)	S14.10.6.1 VOL/VOR/VO markings	S10.18.9.6.1 VOL/VOR/VO markings.
S7.8.5.3(f)(2)(iii)	S14.10.6.2 VOR/VO markings on sealed beams.	S10.18.9.6.2 VOR/VO markings on sealed beams.
S7.8.5.3(f)(2)(iv)	S14.10.6.1 VOL/VOR/VO markings	S10.18.9.6.1 VOL/VOR/VO markings.
S7.8.5.3(f)(2)(v)	S14.10.6 Visual/optical identification marking	S10.18.9.6 Visual/optical identification marking.
S7.9.1(b)	S8.1 Headlighting systems	S6.1.3.5.3 Motorcycle headlamp arrangement.
S7.9.2	S13 Motorcycle headlamp requirements	S10.17 Motorcycle headlighting system.
S7.9.2	S6.8.5 Photometric tests	S14.2 Photometric test procedures.
S7.9.2(a)	S13.2 Photometry	S10.17.3 Photometry.
S7.9.2(b)	S8.1 Headlighting systems	S10.1.2 Motorcycles.
S7.9.3	S6.8.5.6.2(i) Aiming—Motorcycle UB	S14.2.5.5.8 Motorcycle headlamp—upper beam headlamps designed to comply with Table XX.
S7.9.4.1	S13.5 Motorcycle headlamp modulation system.	S10.17.5 Motorcycle headlamp modulation system.
S7.9.4.1(a)	S13.5.1(a) Rate	S10.17.5.1(a) Rate.
S7.9.4.1(b)	S13.5.1(b) Maximum power	S10.17.5.1(b) Maximum power.
S7.9.4.1(c)	S13.5.1(c) Minimum intensity	S10.17.5.1(c) Minimum intensity.
S7.9.4.1(d)	S13.5.1(d) Wiring	S10.17.5.1(d) Wiring.
S7.9.4.1(e)	S13.5.1(e) Failure mode	S10.17.5.1(e) Failure mode.
S7.9.4.1(f)	S13.5.1(f) Sensor	S10.17.5.1(f) Sensor.
S7.9.4.1(g)	S13.5.1(g) Voltage drop	S10.17.5.1(g) Voltage drop.
S7.9.4.1(h)	S13.5.1(h) Full voltage operation	S10.17.5.1(h) Full voltage operation.
S7.9.4.2(a)	S13.5.2 Replacement modulators	S10.17.5.2 Replacement modulators.
S7.9.4.2(a)	S13.5.2.1 Replacement performance	S10.17.5.2.1 Replacement performance.
S7.9.4.2(b)	S13.5.2.2 Replacement instructions	S10.17.5.2.2 Replacement instructions.
S7.9.5	S13.4 Motorcycle replaceable bulb headlamp marking.	S10.17.2 Motorcycle replaceable bulb headlamp marking.
S7.9.6.1	S13.1 Installation	S10.17.1 Installation.
S7.9.6.2(a)	S13.1.1 Single headlamp	S10.17.1.1 Single headlamp.
S7.9.6.2(b)	S13.1.2 Two headlamps with both beams	S10.17.1.2 Two headlamps with both beams.

APPENDIX A.—FMVSS NO. 108 REWRITE CROSS REFERENCE—Continued

Current FMVSS No. 108 or incorporated document citation	FMVSS No. 108 rewrite NPRM citation	FMVSS No. 108 rewrite final rule citation
S7.9.6.2(c)	S13.1.3 Two headlamps, upper beam and lower beam.	S10.17.1.3 Two headlamps, upper beam and lower beam.
S8.2 Abrasion	Table XXIII Abrasion test	S14.6.1 Abrasion test.
S8.2 Abrasion	Table XXIII Abrasion test—procedure	S14.6.1.1 Procedure.
S8.2(a)	Table XXIII Abrasion test—procedure	S14.6.1.1.2 Abrading pad alignment.
S8.2(b)	Table XXIII Abrasion test—procedure	S14.6.1.1.3 Abrasion test procedure.
S8.2(c)(1)	Table XXIII Abrasion test—procedure	S14.6.1.1.1 Abrading pad.
S8.2(c)(3)	Table XXIII Abrasion test—procedure	S14.6.1.1.1 Abrading pad.
S8.2(c)(4)	Table XXIII Abrasion test—procedure	S14.6.1.1.2 Abrading pad alignment.
S8.2(d)	Table XXIII Abrasion test—procedure	S14.6.1.1.3 Abrasion test procedure.
S8.2(e)	Table XXIII Abrasion test—procedure	S14.6.1.1.1 Abrading pad.
S8.3 Chemical resistance	Table XXIII Chemical resistance test	S14.6.2 Chemical resistance test.
S8.3 Chemical resistance	Table XXIII Chemical resistance test—procedure.	S14.6.2.1 Procedure.
S8.3(a)	Table XXIII Chemical resistance test—procedure.	S14.6.2.1.2 Fluid application.
S8.3(b)	Table XXIII Chemical resistance test—procedure.	S14.6.2.1.1 Test fluids.
S8.3(c)	Table XXIII Chemical resistance test—procedure.	S14.6.2.1.3 Test duration.
S8.4 Corrosion	Table XXIII Corrosion—connector test	S14.6.4 Corrosion—connector test.
S8.4 Corrosion	Table XXIII Corrosion—connector test—procedure.	S14.6.4.1 Procedure.
S8.4(a)	Table XXIII Corrosion—connector test—procedure (a).	S14.6.4.1.1 Connector test.
S8.4(a)	S10.7 Physical tests	S10.14.7.2 Connector—corrosion test.
S8.4(a)	S11.7 Physical tests	S10.15.7.1 Corrosion—connector test.
S8.4(b)	Table XXIII Corrosion—connector test—procedure (b).	S14.6.4.1.2 Salt spray.
S8.4(b)	Table XXIII Corrosion—connector test—procedure (b).	S14.6.4.1.3 Cycle.
S8.4(b)	Table XXIII Corrosion—connector test—procedure (b).	S14.6.4.1.4 Chamber.
S8.4(b)	Table XXIII Corrosion—connector test—procedure (b).	S14.6.4.1.5 Wash.
S8.4(c)	Table XXIII Corrosion—connector test—procedure (c).	S14.6.4.1.6 Connector test.
S8.5 Dust	Table XXIII Dust test	S14.6.5 Dust test.
S8.5 Dust	Table XXIII Dust test—procedure	S14.6.5.1 Procedure.
S8.5 Dust	Table XXIII Dust test—procedure	S14.6.5.1.1 Setup.
S8.5 Dust	Table XXIII Dust test—procedure	S14.6.5.1.2 Cycle.
S8.5 Dust	Table XXIII Dust test—procedure	S14.6.5.1.3 Test duration.
S8.6 Temperature and internal heat test	Table XXIII	S14.6.6 Temperature cycle test and internal heat test.
S8.6 Temperature and internal heat test	Table XXIII Temperature cycle test and internal heat test—procedure.	S14.6.6.1 Samples.
S8.6 Temperature and internal heat test	Table XXIII Temperature cycle test and internal heat test—procedure.	S14.6.6.2 General procedure.
S8.6 Temperature and internal heat test	Table XXIII Temperature cycle test and internal heat test—procedure.	S14.6.6.2.1 General activation.
S8.6 Temperature and internal heat test	Table XXIII Temperature cycle test and internal heat test—procedure.	S14.6.6.2.2 Turn signal activation.
S8.6 Temperature and internal heat test	Table XXIII Temperature cycle test and internal heat test—procedure.	S14.6.6.2.3 Headlamp beam activation.
S8.6.1 Temperature cycle	Table XXIII Temperature cycle test	S14.6.6.3 Temperature cycle test.
S8.6.1 Temperature cycle	Table XXIII Temperature cycle test—procedure.	S14.6.6.3.1 Procedure.
S8.6.1 Temperature cycle	Table XXIII Temperature cycle test—procedure.	S14.6.6.3.1.1 Cycle.
S8.6.1 Temperature cycle	Table XXIII Temperature cycle test—procedure.	S14.6.6.3.1.2 Activation.
S8.6.1 Temperature cycle	Table XXIII Temperature cycle test—procedure.	S14.6.6.3.1.3 Test chamber(s).
S8.6.1 Temperature cycle	Table XXIII Temperature cycle test—procedure.	S14.6.6.3.1.4 Vents and drains.
S8.6.2 Internal heat test	Table XXIII Internal heat test	S14.6.6.4 Internal heat test.
S8.6.2 Internal heat test	Table XXIII Internal heat test—procedure	S14.6.6.4.1 Procedure.
S8.6.2(a)	Table XXIII Internal heat test—procedure	S14.6.6.4.1.1 Photometric output reduction.
S8.6.2(a)	Table XXIII Internal heat test—procedure	S14.6.6.4.1.2 HB1 or HB2 light sources.
S8.6.2(a)	Table XXIII Internal heat test—procedure	S14.6.6.4.1.3 Photometric measurements.
S8.6.2(b)	Table XXIII Internal heat test—procedure	S14.6.6.4.1.4 Setup.

APPENDIX A.—FMVSS NO. 108 REWRITE CROSS REFERENCE—Continued

Current FMVSS No. 108 or incorporated document citation	FMVSS No. 108 rewrite NPRM citation	FMVSS No. 108 rewrite final rule citation
S8.6.2(b)	Table XXIII Internal heat test—procedure	S14.6.6.4.1.5 Cycle.
S8.6.2(c)	Table XXIII Internal heat test—procedure	S14.6.6.4.1.6 Cleaning.
S8.7(a)	Table XXIII Humidity test—procedure(a)	S14.6.7.1.1 Test fixture.
S8.7(a)	Table XXIII Humidity test—procedure(a)	S14.6.7.1.2 Headlamp mounting.
S8.7(b)	Table XXIII Humidity test—procedure(b)	S14.6.7.1.3 Setup.
S8.7(b)	Table XXIII Humidity test—procedure(b)	S14.6.7.1.4 Cycle.
S8.7(c)	Table XXIII Humidity test—procedure(c)	S14.6.7.1.5 Air flow test setup.
S8.7(d)	Table XXIII Humidity test—procedure(d)	S14.6.7.1.6 Air flow uniformity.
S8.7(e)	Table XXIII Humidity test—procedure(e)	S14.6.7.1.7 Air flow procedure.
S8.7(f)	Table XXIII Humidity test—procedure(f)	S14.6.7.1.8 Inspection.
S8.8 Vibration	Table XXIII Vibration test	S14.6.8 Vibration test.
S8.8 Vibration	Table XXIII Vibration test—procedure	S14.6.8.2 Procedure.
S8.9 Sealing	Table XXIII Sealing test	S14.6.9 Sealing test.
S8.9 Sealing	Table XXIII Sealing test—procedure	S14.6.9.1 Procedure.
S8.9 Sealing	Table XXIII Sealing test—procedure	S14.6.9.1.1 Immersion.
S8.9 Sealing	Table XXIII Sealing test—procedure	S14.6.9.1.2 Pressurized immersion.
S8.9 Sealing	Table XXIII Sealing test—procedure	S14.6.9.1.3 Cycle.
S8.9 Sealing	Table XXIII Sealing test—procedure	S14.6.9.1.4 Inspection.
S8.9 Sealing	Table XXIII Sealing test—performance requirements.	S14.6.9.2 Performance requirements.
S8.10 Chemical and corrosion resistance of reflectors of replaceable lens headlamps.	Table XXIII Chemical resistance of reflectors of replaceable lens headlamps test.	S14.6.10 Chemical resistance of reflectors of replaceable lens headlamps test.
S8.10 Chemical and corrosion resistance of reflectors of replaceable lens headlamps.	Table XXIII Corrosion resistance of reflectors of replaceable lens headlamps test.	S14.6.11 Corrosion resistance of reflectors of replaceable lens headlamps test.
S8.10.1 Chemical resistance	Table XXIII Chemical resistance of reflectors of replaceable lens headlamps test—procedure.	S14.6.10.1 Procedure.
S8.10.1(a)	Table XXIII Chemical resistance of reflectors of replaceable lens headlamps test—procedure.	S14.6.10.1.2 Fluid application.
S8.10.1(b)	Table XXIII Chemical resistance of reflectors of replaceable lens headlamps test—procedure.	S14.6.10.1.1 Test fluids.
S8.10.1(c)	Table XXIII Chemical resistance of reflectors of replaceable lens headlamps test—procedure.	S14.6.10.1.3 Test duration.
S8.10.2 Corrosion	Table XXIII Corrosion resistance of reflectors of replaceable lens headlamps test—procedure.	S14.6.11.1 Procedure.
S8.10.2(a)	Table XXIII Corrosion resistance of reflectors of replaceable lens headlamps test—procedure.	S14.6.11.1.1 Salt spray.
S8.10.2(b)	Table XXIII Corrosion resistance of reflectors of replaceable lens headlamps test—procedure.	S14.6.11.1.2 Drying and cleaning.
S9 Deflection test for replaceable light sources	Table XXIII Deflection test for replaceable light sources.	S14.7.1 Deflection test for replaceable light sources.
S9 Deflection test for replaceable light sources	Table XXIII Deflection test for replaceable light sources—procedure.	S14.7.1.1 Procedure.
S9 Deflection test for replaceable light sources	Table XXIII Deflection test for replaceable light sources—procedure.	S14.7.1.1.1 Force application.
S9 Deflection test for replaceable light sources	Table XXIII Deflection test for replaceable light sources—procedure.	S14.7.1.1.2 Application sequence.
S9 Deflection test for replaceable light sources	Table XXIII Deflection test for replaceable light sources—procedure.	S14.7.1.1.3 Measurement.
S10(a)	S6.8.5.6 Headlamp photometry measurements.	S14.2.5.3 Measurement distance.
S10(a)	S6.8.5.6.2(g) Aiming—Simultaneous aim	S14.2.5.5.7 Simultaneous aim Type F sealed beam headlamps and beam contributor integral beam headlamps.
S10(b)	S6.8.5.6 Headlamp photometry measurements.	S14.2.5.3 Measurement distance.
S10(b)	S6.8.5.6.2(g) Aiming—Simultaneous aim	S14.2.5.5.7 Simultaneous aim Type F sealed beam headlamps and beam contributor integral beam headlamps.
S11 Photometric Test	S6.8.5.5 Daytime running lamp (DRL) photometry measurements.	S14.2.4.1.
S11 Photometric Test	S6.8.5.5 Daytime running lamp (DRL) photometry measurements.	S14.2.4.2.
S12 Headlamp concealment devices	S16 Headlamp concealment device requirements.	S12 Headlamp concealment device requirements.

APPENDIX A.—FMVSS NO. 108 REWRITE CROSS REFERENCE—Continued

Current FMVSS No. 108 or incorporated document citation	FMVSS No. 108 rewrite NPRM citation	FMVSS No. 108 rewrite final rule citation
S12.1	S16.1 Power loss during headlamp use	S12.1 Power loss during headlamp use.
S12.2	S16.2 Manual device actuation	S12.2 Manual device actuation.
S12.3	S16.3 Single step actuation	S12.3 Single step actuation.
S12.4	S16.4 Headlamp aiming and replacement	S12.4 Headlamp aiming and replacement.
S12.5	S16.5 Operational temperature range and time limitation.	S12.5 Operational temperature range and time limitation.
S12.6	S16.6 ECE compliance alternative	S12.6 ECE compliance alternative.
S12.7 Certification election	S16.7 Certification election	S12.7 Certification election.
Figure 1a	S7.2.1 Photometry	S7.2.13 Photometry.
Figure 1a	S7.8.1 Photometry	S7.8.13 Photometry.
Figure 1a	Table VIII Taillamp—Individual point photometry.	Table VIII Taillamp—Individual point photometry.
Figure 1a	Table VIII Taillamp—Zone photometry	Table VIII Taillamp—Group photometry.
Figure 1a	Table XIV Parking lamp—Individual point photometry.	Table XIV Parking lamp—Individual point photometry.
Figure 1a	Table XIV Parking lamp—Zone photometry	Table XIV Parking lamp—Group photometry.
Figure 1b	S7.2.1 Photometry	S7.2.13 Photometry.
Figure 1b	S7.8.1 Photometry	S7.8.13 Photometry.
Figure 1b	Table VIII Taillamp—Individual point photometry.	Table VIII Taillamp—Individual point photometry.
Figure 1b	Table VIII Taillamp—Zone photometry	Table VIII Taillamp—Group photometry.
Figure 1b	Table XIV Parking lamp—Individual point photometry.	Table XIV Parking lamp—Individual point photometry.
Figure 1b	Table XIV Parking lamp—Zone photometry	Table XIV Parking lamp—Group photometry.
Figure 1b, footnote 1	Table VIII Taillamp—Maximum photometric intensity.	Table VIII Taillamp—Maximum photometric intensity.
Figure 1b, footnote 2	Table XIV Parking lamp—Maximum photometric intensity.	Table XIV Parking lamp—Maximum photometric intensity.
Figure 1c	S7.2.1 Photometry	S7.2.13 Photometry.
Figure 1c	S7.8.1 Photometry	S7.8.13 Photometry.
Figure 1c	Table VIII Taillamp—Individual point photometry.	Table VIII Taillamp—Individual point photometry.
Figure 1c	Table VIII Taillamp—Zone photometry	Table VIII Taillamp—Group photometry.
Figure 1c	Table XIV Parking lamp—Individual point photometry.	Table XIV Parking lamp—Individual point photometry.
Figure 1c	Table XIV Parking lamp—Zone photometry	Table XIV Parking lamp—Group photometry.
Figure 2	S7.6.1 Photometry	S7.6.13 Photometry.
Figure 2, footnote 1	Table XII footnote 2	Table XII footnote 2.
Figure 2, footnote 1	Table XII footnote 3	Table XII footnote 3.
Figure 2, footnote 1	Table XII Single backup lamp system—Zone photometry.	Table XII Single lamp system—Group photometry.
Figure 2, footnote 1	Table XII Two backup lamp system—Zone photometry.	Table XII Two lamp system—Each lamp—Group photometry.
Figure 4–1	Figure 3	Figure 3.
Figure 4–2	Figure 3	Figure 3.
Figure 4–3	Figure 3	Figure 3.
Figure 4–4	Figure 3	Figure 3.
Figure 5	Figure 5	Figure 5.
Figure 6	Figure 6	Figure 6.
Figure 7	Figure 7	Figure 7.
Figure 8	Figure 8	Figure 8.
Figure 9	Figure 9	Figure 9.
Figure 10	S7.9.3 Photometry	S7.9.13 Photometry.
Figure 10	Table XV High mounted stop lamp—Individual point photometry.	Table XV High mounted stop lamp—Individual point photometry.
Figure 10	Table XV High mounted stop lamp—Zone photometry.	Table XV High mounted stop lamp—Group photometry.
Figure 10, footnote 1	Table XV footnote 4	Table XV footnote 4.
Figure 10, footnote 2	Table XV footnote 2	Table XV footnote 2.
Figure 11	Relocated to Part 564, Appendix C	Relocated to Part 564, Appendix C.
Figure 12	Relocated to Part 564, Appendix C	Relocated to Part 564, Appendix C.
Figure 13	Relocated to Part 564, Appendix C	Relocated to Part 564, Appendix C.
Figure 14	Relocated to Part 564, Appendix C	Relocated to Part 564, Appendix C.
Figure 15–1	Table XIX Lower beam #1M photometry	Table XIX–a Lower beam #1M photometry.
Figure 15–1	Table XIX Lower beam #5M photometry	Table XIX–b Lower beam #5M photometry.
Figure 15–1	Table XVIII Upper beam #6 photometry	Table XVIII Upper beam #6 photometry.
Figure 15–1	Table XVIII Upper beam #1 photometry	Table XVIII Upper beam #1 photometry.
Figure 15–2	Table XIX Lower beam #1V photometry	Table XIX–a Lower beam #1V photometry.
Figure 15–2	Table XVIII Upper beam #1 photometry	Table XVIII Upper beam #1 photometry.
Figure 15–2	Table XVIII Upper beam #6 photometry	Table XVIII Upper beam #6 photometry.
Figure 15–2	Table XIX Lower beam #4V photometry	Table XIX–c Lower beam #4V photometry.

APPENDIX A.—FMVSS NO. 108 REWRITE CROSS REFERENCE—Continued

Current FMVSS No. 108 or incorporated document citation	FMVSS No. 108 rewrite NPRM citation	FMVSS No. 108 rewrite final rule citation
Figure 16	Figure 14	Figure 14.
Figure 17-1	Table XIX Lower beam #2M photometry	Table XIX-a Lower beam #2M photometry.
Figure 17-1	Table XVIII Upper beam #2 photometry	Table XVIII Upper beam #2 photometry.
Figure 17-2	Table XIX Lower beam #2V photometry	Table XIX-a Lower beam #2V photometry.
Figure 17-2	Table XVIII Upper beam #2 photometry	Table XVIII Upper beam #2 photometry.
Figure 18	Relocated to Part 564, Appendix C	Relocated to Part 564, Appendix C.
Figure 19	Table V Lens area visibility	Table V-c Lens area visibility.
Figure 19, footnote 2	Table V footnote 3	Table V footnote 3.
Figure 20	Table V Luminous intensity visibility	Table V-d Luminous intensity visibility.
Figure 20, footnote 2	Table V footnote 4	Table V footnote 4.
Figure 21	Relocated to Part 564, Appendix C	Relocated to Part 564, Appendix C.
Figure 22	Figure 15	Figure 15.
Figure 25	Figure 10	Figure 10.
Figure 26	Table II Replaceable bulb headlamps—2 lamp system—with HB2.	Table II-d Replaceable bulb headlamps—2 lamp system—with HB2.
Figure 26	Table II Replaceable bulb headlamps—2 lamp system—without HB2.	Table II-d Replaceable bulb headlamps—2 lamp system—without HB2.
Figure 26	Table II Replaceable bulb headlamps—4 lamp system—with HB2.	Table II-d Replaceable bulb headlamps—4 lamp system—with HB2.
Figure 26	Table II Replaceable bulb headlamps—4 lamp system—without HB2.	Table II-d Replaceable bulb headlamps—4 lamp system—without HB2.
Figure 27-1	Table XIX Lower beam #3M photometry	Table XIX-b Lower beam #3M photometry.
Figure 27-1	Table XVIII Upper beam #3 photometry	Table XVIII Upper beam #3 photometry.
Figure 27-2	Table XIX Lower beam #3V photometry	Table XIX-b Lower beam #3V photometry.
Figure 27-2	Table XVIII Upper beam #3 photometry	Table XVIII Upper beam #3 photometry.
Figure 28-1, Types 1A1, 1C1, and 1G1	Table XVIII Upper beam #4 photometry	Table XVIII Upper beam #4 photometry.
Figure 28-1, Types 2A1, 2C1, and 2G1	Table XVIII Upper beam #5 photometry	Table XVIII Upper beam #5 photometry.
Figure 28-2, Types 1A1, 1C1, and 1G1	Table XVIII Upper beam #4 photometry	Table XVIII Upper beam #4 photometry.
Figure 28-2, Types 2A1, 2C1 and 2G1	Table XIX Lower beam #2V photometry	Table XIX-a Lower beam #2V photometry.
Figure 28-2, Types 2A1, 2C1, and 2G1	Table XIX Lower beam #4M photometry	Table XIX-b Lower beam #4M photometry.
Figure 28-2, Types 2A1, 2C1, and 2G1	Table XVIII Upper beam #5 photometry	Table XVIII Upper beam #5 photometry.
Figure 29	S7.12.1.2 Photometry	S8.2.1.7 Photometry.
Figure 29	Table XVI Red C2 sheeting photometry	Table XVI-c Red C2 sheeting photometry.
Figure 29	Table XVI Red C3 sheeting photometry	Table XVI-c Red C3 sheeting photometry.
Figure 29	Table XVI Red C4 sheeting photometry	Table XVI-c Red C4 sheeting photometry.
Figure 29	Table XVI White C2 sheeting photometry	Table XVI-c White C2 sheeting photometry.
Figure 29	Table XVI White C3 sheeting photometry	Table XVI-c White C3 sheeting photometry.
Figure 29	Table XVI White C4 sheeting photometry	Table XVI-c White C4 sheeting photometry.
Figure 30-1	Figure 11	Figure 11.
Figure 30-2	Figure 11	Figure 11.
Figure 30-3	Figure 11	Figure 11.
Figure 30-4	Figure 11	Figure 11.
Figure 31	Figure 13	Figure 13.
Figure 32	Table XX Motor driven cycle photometry	Table XX Motor driven cycle photometry.
Figure 32	Table XX Motor driven cycle with single lamp photometry.	Table XX Motor driven cycle with single lamp photometry.
Figure 32	Table XX Motorcycle photometry	Table XX Motorcycle photometry.
Table I	S1 Scope	S1 Scope.
Table I	S6.1 Required lamps, reflective devices, and associated equipment by vehicle type.	S6.1 Required lamps, reflective devices, and associated equipment by vehicle type.
Table I	S6.1.1 Quantity	S6.1.1 Quantity.
Table I	S6.1.2 Color	S6.1.2 Color.
Table I	S6.6 Associated equipment	S6.6.1 All except trailers.
Table I	S6.6 Associated equipment	S6.6.2 All except trailers and motorcycles.
Table I	S7.14 Associated equipment	S9 Associated equipment requirements.
Table I	Table I Lighting device	Table I-a Lighting device.
Table I	Table I Lighting device	Table I-b Lighting device.
Table I	Table I Mounting height	Table I-a Mounting height.
Table I	Table I Mounting height	Table I-b Mounting height.
Table I	Table I Mounting location	Table I-a Mounting location.
Table I	Table I Mounting location	Table I-b Mounting location.
Table I	Table I Number and color	Table I-a Number and color.
Table I	Table I Number and color	Table I-b Number and color.
Table II	S6.1 Required lamps, reflective devices, and associated equipment by vehicle type.	S6.1 Required lamps, reflective devices, and associated equipment by vehicle type.
Table II	S6.1.1 Quantity	S6.1.1 Quantity.
Table II	S6.1.2 Color	S6.1.2 Color.
Table II	S6.1.3 Mounting location and height	S6.1.3.1.
Table II	S6.1.3 Mounting location and height	S6.1.3.2.
Table II	Table I Lighting device	Table I-a Lighting device.
Table II	Table I Lighting device	Table I-b Lighting device.

APPENDIX A.—FMVSS NO. 108 REWRITE CROSS REFERENCE—Continued

Current FMVSS No. 108 or incorporated document citation	FMVSS No. 108 rewrite NPRM citation	FMVSS No. 108 rewrite final rule citation
Table II	Table I Mounting height	Table I-a Mounting height.
Table II	Table I Mounting height	Table I-b Mounting height.
Table II	Table I Mounting location	Table I-a Mounting location.
Table II	Table I Mounting location	Table I-b Mounting location.
Table II	Table I Number and color	Table I-a Number and color.
Table II	Table I Number and color	Table I-b Number and color.
Table II heading	S6.1.3.1 Mounting height	S6.1.4 Mounting height.
Table III	S1 Scope	S1 Scope.
Table III	S6.1 Required lamps, reflective devices, and associated equipment by vehicle type.	S6.1 Required lamps, reflective devices, and associated equipment by vehicle type.
Table III	S6.1.1 Quantity	S6.1.1 Quantity.
Table III	S6.1.2 Color	S6.1.2 Color.
Table III	S6.6 Associated equipment	S6.6.1 All except trailers.
Table III	S6.6 Associated equipment	S6.6.2 All except trailers and motorcycles.
Table III	S7.14 Associated equipment	S9 Associated equipment requirements.
Table III	Table I Lighting device	Table I-a Lighting device.
Table III	Table I Lighting device	Table I-b Lighting device.
Table III	Table I Lighting device	Table I-c Lighting device.
Table III	Table I Mounting height	Table I-a Mounting height.
Table III	Table I Mounting height	Table I-b Mounting height.
Table III	Table I Mounting height	Table I-c Mounting height.
Table III	Table I Mounting location	Table I-a Mounting location.
Table III	Table I Mounting location	Table I-b Mounting location.
Table III	Table I Mounting location	Table I-c Mounting location.
Table III	Table I Number and color	Table I-a Number and color.
Table III	Table I Number and color	Table I-b Number and color.
Table III	Table I Number and color	Table I-c Number and color.
Table IV	S6.1 Required lamps, reflective devices, and associated equipment by vehicle type.	S6.1 Required lamps, reflective devices, and associated equipment by vehicle type.
Table IV	S6.1.1 Quantity	S6.1.1 Quantity.
Table IV	S6.1.2 Color	S6.1.2 Color.
Table IV	S6.1.3 Mounting location and height	S6.1.3.1.
Table IV	S6.1.3 Mounting location and height	S6.1.3.2.
Table IV	Table I Lighting device	Table I-a Lighting device.
Table IV	Table I Lighting device	Table I-b Lighting device.
Table IV	Table I Lighting device	Table I-c Lighting device.
Table IV	Table I Mounting height	Table I-a Mounting height.
Table IV	Table I Mounting height	Table I-b Mounting height.
Table IV	Table I Mounting height	Table I-c Mounting height.
Table IV	Table I Mounting location	Table I-a Mounting location.
Table IV	Table I Mounting location	Table I-b Mounting location.
Table IV	Table I Mounting location	Table I-c Mounting location.
Table IV	Table I Number and color	Table I-a Number and color.
Table IV	Table I Number and color	Table I-b Number and color.
Table IV	Table I Number and color	Table I-c Number and color.
Table IV, footnotes 2 and 3	Omitted	S14.2.1.6.2 Socket exemption.
Table IV heading	S6.1.3.1 Mounting height	S6.1.4 Mounting height.
Table IV, footnote 1	S4 Definitions—Overall width	S4 Definitions—Overall width.
SAE device documents for photometry distance	S6.8.5.1 Photometry ex headlamp, license lamp, & DRL.	S14.2.1.3 Measurement distance.
SAE device documents referencing SAE J575	S6.8.1 Physical test requirements	S14.1.1 Physical test requirements.
SAE device documents referencing SAE J575	S6.8.5 Photometric tests	S14.2 Photometric test procedures.
SAE J186a, Sep 1977, 2.1	S4 Definitions—High mounted stop lamp	S4 Definitions—High mounted stop lamp.
SAE J186a, Sep 1977, 3	S7.9.4 Physical tests	S7.9.14 Physical tests.
SAE J186a, Sep 1977, 3	S7.9.4 Physical tests	S7.9.14.1 External mount.
SAE J186a, Sep 1977, 3	S7.9.4 Physical tests	S7.9.14.2 Internal mount.
SAE J222, Dec 1970, 2	S4 Definitions—Parking lamps	S4 Definitions—Parking lamps.
SAE J222, Dec 1970, 3	S7.8.2 Physical tests	S7.8.14 Physical tests.
SAE J387, Nov 1987	S4 Definitions—Optically combined	S4 Definitions—Optically combined.
SAE J564a, Apr 1964	S7.14.4 Headlamp beam switching device	S9.4 Headlamp beam switching device.
SAE J564a, Apr 1964	S7.14.5.1 Indicator size and location	S9.5.1 Indicator size, location, and color.
SAE J565b, Feb 1969	S7.14.4.1 Semi-automatic headlamp beam switching device.	S9.4.1 Semi-automatic headlamp beam switching device.
SAE J565b, Feb 1969	Table XXI	S9.4.1.7 Physical tests.
SAE J565b, Feb 1969	Table XXI Semiautomatic headlamp beam switching device tests.	S14.9.3.11 Semiautomatic headlamp beam switching device tests.
SAE J565b, Feb 1969, 1	S4 Definitions—Semiautomatic headlamp beam switching device.	S4 Definitions—Semiautomatic headlamp beam switching device.
SAE J565b, Feb 1969, 2	S7.14.4.1.1 Operating instructions	S9.4.1.1 Operating instructions.
SAE J565b, Feb 1969, 4	Table XXI Semiautomatic headlamp beam switching device sensitivity test.	S14.9.3.11.2 Sensitivity test.

APPENDIX A.—FMVSS NO. 108 REWRITE CROSS REFERENCE—Continued

Current FMVSS No. 108 or incorporated document citation	FMVSS No. 108 rewrite NPRM citation	FMVSS No. 108 rewrite final rule citation
SAE J565b, Feb 1969, 4.1	Table XXI Semiautomatic headlamp beam switching device sensitivity test—procedure.	S14.9.3.11.2.1 Samples.
SAE J565b, Feb 1969, 4.2	Table XXI Semiautomatic headlamp beam switching device sensitivity test—performance requirements.	S14.9.3.11.2.3 Performance requirements.
SAE J565b, Feb 1969, 4.2	Table XXI Semiautomatic headlamp beam switching device sensitivity test—performance requirements.	S14.9.3.11.2.3.1 Operating limits.
SAE J565b, Feb 1969, 4.2	Table XXI Semiautomatic headlamp beam switching device sensitivity test—performance requirements.	S14.9.3.11.2.3.2 Sensitivity voids.
SAE J565b, Feb 1969, 4.2	Table XXI Semiautomatic headlamp beam switching device sensitivity test—procedure.	S14.9.3.11.2.2 Procedure.
SAE J565b, Feb 1969, 4.2	Table XXI Semiautomatic headlamp beam switching device sensitivity test—procedure.	S14.9.3.11.2.2.1 Adjustment.
SAE J565b, Feb 1969, 4.2	Table XXI Semiautomatic headlamp beam switching device sensitivity test—procedure.	S14.9.3.11.2.2.2 Switching.
SAE J565b, Feb 1969, 4.2	Table XXI Semiautomatic headlamp beam switching device sensitivity test—procedure.	S14.9.3.11.2.2.3 Sensitivity curves.
SAE J565b, Feb 1969, 4.2	Table XXI Semiautomatic headlamp beam switching device tests—applicable item.	S14.9.3.11.1 Test conditions.
SAE J565b, Feb 1969, 4.3	Table XXI Semiautomatic headlamp beam switching device voltage regulation test.	S14.9.3.11.3 Voltage regulation test.
SAE J565b, Feb 1969, 4.3	Table XXI Semiautomatic headlamp beam switching device voltage regulation test—performance requirements.	S14.9.3.11.3.2 Performance requirements.
SAE J565b, Feb 1969, 4.3	Table XXI Semiautomatic headlamp beam switching device voltage regulation test—procedure.	S14.9.3.11.3.1 Procedure.
SAE J565b, Feb 1969, 4.3	Table XXI Semiautomatic headlamp beam switching device voltage regulation test—procedure.	S14.9.3.11.3.1.1 Adjustment.
SAE J565b, Feb 1969, 4.3	Table XXI Semiautomatic headlamp beam switching device voltage regulation test—procedure.	S14.9.3.11.3.1.2 Measurement.
SAE J565b, Feb 1969, 4.4	S7.14.4.1.2 Manual override	S9.4.1.2 Manual override.
SAE J565b, Feb 1969, 4.4	Table XXI Semiautomatic headlamp beam switching device manual override test.	S14.9.3.11.4 Manual override test.
SAE J565b, Feb 1969, 4.4	Table XXI Semiautomatic headlamp beam switching device manual override test—performance requirements.	S14.9.3.11.4.2 Performance requirements.
SAE J565b, Feb 1969, 4.4	Table XXI Semiautomatic headlamp beam switching device manual override test—procedure.	S14.9.3.11.4.1 Procedure.
SAE J565b, Feb 1969, 4.4	Table XXI Semiautomatic headlamp beam switching device manual override test—procedure.	S14.9.3.11.4.1.1 Adjustment.
SAE J565b, Feb 1969, 4.4	Table XXI Semiautomatic headlamp beam switching device manual override test—procedure.	S14.9.3.11.4.1.2 Exposure.
SAE J565b, Feb 1969, 4.4	Table XXI Semiautomatic headlamp beam switching device manual override test—procedure.	S14.9.3.11.4.1.3 Override.
SAE J565b, Feb 1969, 4.4	Table XXI Semiautomatic headlamp beam switching device manual override test—procedure.	S14.9.3.11.4.1.4 Switch to upper beam.
SAE J565b, Feb 1969, 4.4	Table XXI Semiautomatic headlamp beam switching device manual override test—procedure.	S14.9.3.11.4.1.5 Switch to lower beam.
SAE J565b, Feb 1969, 4.5	Table XXI Semiautomatic headlamp beam switching device warmup test.	S14.9.3.11.5 Warmup test.
SAE J565b, Feb 1969, 4.5	Table XXI Semiautomatic headlamp beam switching device warmup test—performance requirements.	S14.9.3.11.5.2 Performance requirements.
SAE J565b, Feb 1969, 4.5	Table XXI Semiautomatic headlamp beam switching device warmup test—procedure.	S14.9.3.11.5.1 Procedure.
SAE J565b, Feb 1969, 4.5	Table XXI Semiautomatic headlamp beam switching device warmup test—procedure.	S14.9.3.11.5.1.1 Adjustment.
SAE J565b, Feb 1969, 4.5	Table XXI Semiautomatic headlamp beam switching device warmup test—procedure.	S14.9.3.11.5.1.2 Measurement.
SAE J565b, Feb 1969, 4.6	S7.14.4.1.3 Fail safe operation	S9.4.1.3 Fail safe operation.

APPENDIX A.—FMVSS NO. 108 REWRITE CROSS REFERENCE—Continued

Current FMVSS No. 108 or incorporated document citation	FMVSS No. 108 rewrite NPRM citation	FMVSS No. 108 rewrite final rule citation
SAE J565b, Feb 1969, 4.7	Table XXI Semiautomatic headlamp beam switching device temperature test.	S14.9.3.11.6 Temperature test.
SAE J565b, Feb 1969, 4.7	Table XXI Semiautomatic headlamp beam switching device temperature test—performance requirements.	S14.9.3.11.6.2 Performance requirements.
SAE J565b, Feb 1969, 4.7	Table XXI Semiautomatic headlamp beam switching device temperature test—procedure.	S14.9.3.11.6.1 Procedure.
SAE J565b, Feb 1969, 4.7	Table XXI Semiautomatic headlamp beam switching device temperature test—procedure.	S14.9.3.11.6.1.1 Exposure.
SAE J565b, Feb 1969, 4.7	Table XXI Semiautomatic headlamp beam switching device temperature test—procedure.	S14.9.3.11.6.1.2 Temperature.
SAE J565b, Feb 1969, 4.7	Table XXI Semiautomatic headlamp beam switching device temperature test—procedure.	S14.9.3.11.6.1.3 Measurement.
SAE J565b, Feb 1969, 4.8	Table XXI Semiautomatic headlamp beam switching device dust test.	S14.9.3.11.7 Dust test.
SAE J565b, Feb 1969, 4.8	Table XXI Semiautomatic headlamp beam switching device dust test—performance requirements.	S14.9.3.11.7.2 Performance requirements.
SAE J565b, Feb 1969, 4.8	Table XXI Semiautomatic headlamp beam switching device dust test—procedure.	S14.9.3.11.7.1 Procedure.
SAE J565b, Feb 1969, 4.8	Table XXI Semiautomatic headlamp beam switching device dust test—procedure.	S14.9.3.11.7.1.1 Sensitivity.
SAE J565b, Feb 1969, 4.8	Table XXI Semiautomatic headlamp beam switching device dust test—procedure.	S14.9.3.11.7.1.2 Dust exposure.
SAE J565b, Feb 1969, 4.8	Table XXI Semiautomatic headlamp beam switching device dust test—procedure.	S14.9.3.11.7.1.3 Measurement.
SAE J565b, Feb 1969, 4.9	Table XXI Semiautomatic headlamp beam switching device corrosion test.	S14.9.3.11.8 Corrosion test.
SAE J565b, Feb 1969, 4.9	Table XXI Semiautomatic headlamp beam switching device corrosion test—performance requirements.	S14.9.3.11.8.2 Performance requirements.
SAE J565b, Feb 1969, 4.9	Table XXI Semiautomatic headlamp beam switching device corrosion test—procedure.	S14.9.3.11.8.1 Procedure.
SAE J565b, Feb 1969, 4.9	Table XXI Semiautomatic headlamp beam switching device corrosion test—procedure.	S14.9.3.11.8.1.1 Sensitivity.
SAE J565b, Feb 1969, 4.9	Table XXI Semiautomatic headlamp beam switching device corrosion test—procedure.	S14.9.3.11.8.1.2 Applicability.
SAE J565b, Feb 1969, 4.9	Table XXI Semiautomatic headlamp beam switching device corrosion test—procedure.	S14.9.3.11.8.1.3 Sockets.
SAE J565b, Feb 1969, 4.9	Table XXI Semiautomatic headlamp beam switching device corrosion test—procedure.	S14.9.3.11.8.1.4 Measurement.
SAE J565b, Feb 1969, 4.10	Table XXI Semiautomatic headlamp beam switching device vibration test.	S14.9.3.11.9 Vibration test.
SAE J565b, Feb 1969, 4.10	Table XXI Semiautomatic headlamp beam switching device vibration test—performance requirements.	S14.9.3.11.9.2 Performance requirements.
SAE J565b, Feb 1969, 4.10	Table XXI Semiautomatic headlamp beam switching device vibration test—performance requirements.	S14.9.3.11.9.2.1 Beam switching.
SAE J565b, Feb 1969, 4.10	Table XXI Semiautomatic headlamp beam switching device vibration test—performance requirements.	S14.9.3.11.9.2.2 Mechanical aim.
SAE J565b, Feb 1969, 4.10	Table XXI Semiautomatic headlamp beam switching device vibration test—procedure.	S14.9.3.11.9.1 Procedure.
SAE J565b, Feb 1969, 4.10	Table XXI Semiautomatic headlamp beam switching device vibration test—procedure.	S14.9.3.11.9.1.1 Sensitivity.
SAE J565b, Feb 1969, 4.10	Table XXI Semiautomatic headlamp beam switching device vibration test—procedure.	S14.9.3.11.9.1.5 Measurement.
SAE J565b, Feb 1969, 4.10(a)	Table XXI Semiautomatic headlamp beam switching device vibration test—procedure.	S14.9.3.11.9.1.2 Acceleration.
SAE J565b, Feb 1969, 4.10(b)	Table XXI Semiautomatic headlamp beam switching device vibration test—procedure.	S14.9.3.11.9.1.3 Frequency.
SAE J565b, Feb 1969, 4.10(c)	Table XXI Semiautomatic headlamp beam switching device vibration test—procedure.	S14.9.3.11.9.1.4 Operation.
SAE J565b, Feb 1969, 4.11	Table XXI Semiautomatic headlamp beam switching device sunlight test.	S14.9.3.11.10 Sunlight test.

APPENDIX A.—FMVSS NO. 108 REWRITE CROSS REFERENCE—Continued

Current FMVSS No. 108 or incorporated document citation	FMVSS No. 108 rewrite NPRM citation	FMVSS No. 108 rewrite final rule citation
SAE J565b, Feb 1969, 4.11	Table XXI Semiautomatic headlamp beam switching device sunlight test—performance requirements.	S14.9.3.11.10.2 Performance requirements.
SAE J565b, Feb 1969, 4.11	Table XXI Semiautomatic headlamp beam switching device sunlight test—procedure.	S14.9.3.11.10.1 Procedure.
SAE J565b, Feb 1969, 4.11	Table XXI Semiautomatic headlamp beam switching device sunlight test—procedure.	S14.9.3.11.10.1.1 Exposure.
SAE J565b, Feb 1969, 4.11	Table XXI Semiautomatic headlamp beam switching device sunlight test—procedure.	S14.9.3.11.10.1.2 Rest.
SAE J565b, Feb 1969, 4.12	Table XXI Semiautomatic headlamp beam switching device durability test.	S14.9.3.11.11 Durability test.
SAE J565b, Feb 1969, 4.12	Table XXI Semiautomatic headlamp beam switching device durability test—performance requirements.	S14.9.3.11.11.2 Performance requirements.
SAE J565b, Feb 1969, 4.12	Table XXI Semiautomatic headlamp beam switching device durability test—procedure.	S14.9.3.11.11.1 Procedure.
SAE J565b, Feb 1969, 4.12	Table XXI Semiautomatic headlamp beam switching device durability test—procedure.	S14.9.3.11.11.1.1 Sensitivity.
SAE J565b, Feb 1969, 4.12	Table XXI Semiautomatic headlamp beam switching device durability test—procedure.	S14.9.3.11.11.1.3 Measurement.
SAE J565b, Feb 1969, 4.12(a)	Table XXI Semiautomatic headlamp beam switching device durability test—procedure.	S14.9.3.11.11.1.2 Cycle.
SAE J565b, Feb 1969, 4.12(b)	Table XXI Semiautomatic headlamp beam switching device durability test—procedure.	S14.9.3.11.11.1.2 Cycle.
SAE J565b, Feb 1969, 4.13	S7.14.4.1.4 Automatic dimming indicator	S9.4.1.4 Automatic dimming indicator.
SAE J565b, Feb 1969, 4.15	Table XXI Semiautomatic headlamp beam switching device return to upper beam test.	S14.9.3.11.12 Return to upper beam test.
SAE J565b, Feb 1969, 4.15	Table XXI Semiautomatic headlamp beam switching device return to upper beam test—performance requirements.	S14.9.3.11.12.2 Performance requirements.
SAE J565b, Feb 1969, 4.15	Table XXI Semiautomatic headlamp beam switching device return to upper beam test—procedure.	S14.9.3.11.12.1 Procedure.
SAE J565b, Feb 1969, 4.15	Table XXI Semiautomatic headlamp beam switching device return to upper beam test—procedure.	S14.9.3.11.12.1.1 Sensitivity.
SAE J565b, Feb 1969, 4.15	Table XXI Semiautomatic headlamp beam switching device return to upper beam test—procedure.	S14.9.3.11.12.1.2 Exposure.
SAE J565b, Feb 1969, 4.16	S7.14.4.1.5 Lens accessibility	S9.4.1.5 Lens accessibility.
SAE J565b, Feb 1969, 4.17	S7.14.4.1.6 Mounting height	S9.4.1.6 Mounting height.
SAE J566, Jan 1960, 1	S8.1.5 Headlamp adjustments	S10.18.1.1 Adjustments.
SAE J566, Jan 1960, 2	S8.1.5 Headlamp adjustments	S10.18.1.2 Procedure & security.
SAE J566, Jan 1960, 3	S8.1.5 Headlamp adjustments	S10.18.1.2 Procedure & security.
SAE J575, Dec 1988, 2.1	S6.8.2 Samples for test	S14.1.4.2 Mounting bracket.
SAE J575, Dec 1988, 2.3	S6.8.2 [fourth sentence]	S14.6.8.1 Samples.
SAE J575, Dec 1988, 2.3	S6.8.2 Samples for test	S14.1.4.2 Mounting bracket.
SAE J575, Dec 1988, 3	S6.8.3 Laboratory facilities	S14.1.5 Laboratory facilities.
SAE J575, Dec 1988, 4.1	Table XXIII Vibration test—procedure	S14.6.8.2 Procedure.
SAE J575, Dec 1988, 4.4	Table XXIII Corrosion test—performance requirements.	S14.6.3.2 Performance requirements.
SAE J575, Dec 1988, 4.4	Table XXIII Corrosion test—procedure	S14.6.3.1 Procedure.
SAE J575, Dec 1988, 4.4	Table XXIII VHAD corrosion test—performance requirements.	S14.8.6.2 Performance requirements.
SAE J575, Dec 1988, 4.4	Table XXIII VHAD corrosion test—procedure	S14.8.6.1 Procedure.
SAE J575, Dec 1988, 4.6.2.1	S6.8.5.6.3 Positioner	S14.2.5.6 Positioner.
SAE J575, Dec 1988, 4.6.2.2	S6.8.5.6.4 Photometer	S14.2.5.7.1 Range.
SAE J575, Dec 1988, 4.6.2.3	S6.8.5.6.4 Photometer	S14.2.5.7.2 Sensor.
SAE J575, Dec 1988, 4.6.2.3.1	S6.8.5.6.4 Photometer	S14.2.5.7.2.1 Effective area.
SAE J575, Dec 1988, 4.6.2.3.1	S6.8.5.6.4 Photometer	S14.2.5.7.2.2 Intercepted light.
SAE J575, Dec 1988, 4.6.2.3.1	S6.8.5.6.4 Photometer	S14.2.5.7.2.3 Direct illumination.
SAE J575, Dec 1988, 4.6.2.3.2	S6.8.5.6.4 Photometer	S14.2.5.7.3 Color response.
SAE J575, Dec 1988, 4.6.3	S6.8.5.6 Headlamp photometry measurements.	S14.2.5.1 Mounting.
SAE J575, Dec 1988, 4.6.3.3	S6.8.5.6.5 Location of test points	S14.2.5.8 Location of test points.
SAE J575, Dec 1988, 4.6.3.3	S6.8.5.6.5 Location of test points	S14.2.5.8.1 Nomenclature.
SAE J575, Dec 1988, 4.6.3.3	S6.8.5.6.5 Location of test points	S14.2.5.8.1.1 “H–V”.
SAE J575, Dec 1988, 4.6.3.3	S6.8.5.6.5 Location of test points	S14.2.5.8.1.2 “U” “D” “L” “R”.
SAE J575, Dec 1988, 4.6.3.3	S6.8.5.6.5 Location of test points	S14.2.5.8.1.3 Angles.
SAE J575, Dec 1988, 4.6.3.4	S6.8.5.6.1 Seasoning and test voltage	S14.2.5.4 Seasoning and test voltage.
SAE J575d, Aug 1967, B	S6.8.2 Samples for test	S14.1.4.3 Second sample set.

APPENDIX A.—FMVSS NO. 108 REWRITE CROSS REFERENCE—Continued

Current FMVSS No. 108 or incorporated document citation	FMVSS No. 108 rewrite NPRM citation	FMVSS No. 108 rewrite final rule citation
SAE J575d, Aug 1967, D	S6.8.3 Laboratory facilities	S14.1.5 Laboratory facilities.
SAE J575d, Aug 1967, E	Table XXII Vibration test	S14.5.1 Vibration test.
SAE J575d, Aug 1967, E	Table XXII Vibration test—performance requirements.	S14.5.1.2 Performance requirements.
SAE J575d, Aug 1967, E	Table XXII Vibration test—procedure	S14.5.1.1 Procedure.
SAE J575d, Aug 1967, F	Table XXII Moisture test	S14.5.2 Moisture test.
SAE J575d, Aug 1967, F	Table XXII Moisture test—performance requirements.	S14.5.2.2 Performance requirements.
SAE J575d, Aug 1967, F	Table XXII Moisture test—procedure	S14.5.2.1 Procedure.
SAE J575d, Aug 1967, G	Table XXII Dust test	S14.5.3 Dust test.
SAE J575d, Aug 1967, G	Table XXII Dust test	S14.5.3.1 Samples.
SAE J575d, Aug 1967, G	Table XXII Dust test—performance requirements.	S14.5.3.2 Procedure (third sentence).
SAE J575d, Aug 1967, G	Table XXII Dust test—performance requirements.	S14.5.3.3 Dust test—performance requirements.
SAE J575d, Aug 1967, G	Table XXII Dust test—procedure	S14.5.3.2 Procedure.
SAE J575d, Aug 1967, H	Table XXII Corrosion test	S14.5.4 Corrosion test.
SAE J575d, Aug 1967, H	Table XXII Corrosion test—performance requirements.	S14.5.4.2 Performance requirements.
SAE J575d, Aug 1967, H	Table XXII Corrosion test—procedure	S14.5.4.1 Procedure.
SAE J575d, Aug 1967, J	S6.8.5.1 Photometry ex headlamp, license lamp, & DRL.	S14.2.1.1 Mounting.
SAE J575d, Aug 1967, J	S6.8.5.1.1 Location of test points	S14.2.1.4 Location of test points.
SAE J575d, Aug 1967, J	Table X footnote 2	Table X footnote 2.
SAE J575d, Aug 1967, J	Table XI footnote 2	Table XI footnote 2.
SAE J575d, Aug 1967, J	Table XII footnote 1	Table XII footnote 1.
SAE J575d, Aug 1967, J	Table XIV footnote 1	Table XIV footnote 1.
SAE J575d, Aug 1967, J	Table XVII footnote 2	Table XVII footnote 2.
SAE J575d, Aug 1967, J	Table XVII Red lamp photometry	Table XVII Red lamp photometry.
SAE J575d, Aug 1967, K	Table XXII Out of focus test	S14.3 Out of focus test.
SAE J575d, Aug 1967, K	Table XXII Out of focus test—performance requirements.	S14.3.2 Performance requirements.
SAE J575d, Aug 1967, K	Table XXII Out of focus test—procedure	S14.3.1 Procedure.
SAE J575e, Aug 1970, B	S6.8.2 Samples for test	S14.1.4.3 Second sample set.
SAE J575e, Aug 1970, D	S6.8.3 Laboratory facilities	S14.1.5 Laboratory facilities.
SAE J575e, Aug 1970, E	Table XXII Vibration test	S14.5.1 Vibration test.
SAE J575e, Aug 1970, E	Table XXII Vibration test—performance requirements.	S14.5.1.2 Performance requirements.
SAE J575e, Aug 1970, E	Table XXII Vibration test—procedure	S14.5.1.1 Procedure.
SAE J575e, Aug 1970, F	Table XXII Moisture test	S14.5.2 Moisture test.
SAE J575e, Aug 1970, F	Table XXII Moisture test—performance requirements.	S14.5.2.2 Performance requirements.
SAE J575e, Aug 1970, F	Table XXII Moisture test—procedure	S14.5.2.1 Procedure.
SAE J575e, Aug 1970, G	Table XXII Dust test	S14.5.3 Dust test.
SAE J575e, Aug 1970, G	Table XXII Dust test	S14.5.3.1 Samples.
SAE J575e, Aug 1970, G	Table XXII Dust test—performance requirements.	S14.5.3.2 Procedure (third sentence).
SAE J575e, Aug 1970, G	Table XXII Dust test—performance requirements.	S14.5.3.3 Dust test—performance requirements.
SAE J575e, Aug 1970, G	Table XXII Dust test—procedure	S14.5.3.2 Procedure.
SAE J575e, Aug 1970, H	Table XXII Corrosion test	S14.5.4 Corrosion test.
SAE J575e, Aug 1970, H	Table XXII Corrosion test—performance requirements.	S14.5.4.2 Performance requirements.
SAE J575e, Aug 1970, H	Table XXII Corrosion test—procedure	S14.5.4.1 Procedure.
SAE J575e, Aug 1970, J	S6.8.5.1 Photometry ex headlamp, license lamp, & DRL.	S14.2.1.1 Mounting.
SAE J575e, Aug 1970, J	S6.8.5.1.1 Location of test points	S14.2.1.4 Location of test points.
SAE J575e, Aug 1970, J	Standard note—new table	Table XIII—a footnote 2.
SAE J575e, Aug 1970, J	Table VI footnote 2	Table VI footnote 2.
SAE J575e, Aug 1970, J	Table VII footnote 2	Table VII footnote 2.
SAE J575e, Aug 1970, J	Table VIII footnote 1	Table VIII footnote 1.
SAE J575e, Aug 1970, J	Table IX footnote 2	Table IX footnote 2.
SAE J575e, Aug 1970, J	Table XV footnote 1	Table XV footnote 1.
SAE J576, Jul 1991, 2.2.1	S4 Definitions—Material [OUT OF ALPHABETICAL ORDER].	S4 Definitions—Material.
SAE J576, Jul 1991, 2.2.1.1	S4 Definitions—Coated materials	S4 Definitions—Coated materials.
SAE J576, Jul 1991, 2.2.2.1	S4 Definitions—Exposed	S4 Definitions—Exposed.
SAE J576, Jul 1991, 2.2.2.2	S4 Definitions—Protected	S4 Definitions—Protected.
SAE J576, Jul 1991, 2.2.3.1	S4 Definitions—Color bleeding	S4 Definitions—Color bleeding.
SAE J576, Jul 1991, 2.2.3.2	S4 Definitions—Crazing	S4 Definitions—Crazing.
SAE J576, Jul 1991, 2.2.3.3	S4 Definitions—Cracking	S4 Definitions—Cracking.

APPENDIX A.—FMVSS NO. 108 REWRITE CROSS REFERENCE—Continued

Current FMVSS No. 108 or incorporated document citation	FMVSS No. 108 rewrite NPRM citation	FMVSS No. 108 rewrite final rule citation
SAE J576, Jul 1991, 2.2.3.4	S4 Definitions—Haze	S4 Definitions—Haze.
SAE J576, Jul 1991, 2.2.3.5	S4 Definitions—Delamination	S4 Definitions—Delamination.
SAE J576, Jul 1991, 3	Table XXII Plastic optical material tests—procedure.	S14.4.2.2.3 Procedure.
SAE J576, Jul 1991, 3.1	Table XXII Plastic optical material tests	S14.4.2.2.2 Material composition.
SAE J576, Jul 1991, 3.2	Table XXII Plastic optical material tests—samples.	S14.4.2.1 Samples.
SAE J576, Jul 1991, 3.2 Note	Table XXII Plastic optical material tests—samples.	S14.4.2.1.5 Control samples.
SAE J576, Jul 1991, 3.2.1	Table XXII Plastic optical material tests—samples.	S14.4.2.1.1 Molded samples.
SAE J576, Jul 1991, 3.2.1	Table XXII Plastic optical material tests—samples.	S14.4.2.1.2 Exposed area.
SAE J576, Jul 1991, 3.2.2	Table XXII Plastic optical material tests—samples.	S14.4.2.1.3 Thickness.
SAE J576, Jul 1991, 3.3	Table XXII Plastic optical material tests	S14.4.2.2 Outdoor exposure test.
SAE J576, Jul 1991, 3.3.1	Table XXII Plastic optical material tests	S14.4.2.2.1 Location and duration.
SAE J576, Jul 1991, 3.3.2	Table XXII Plastic optical material tests—procedure.	S14.4.2.2.3.1 Mounting.
SAE J576, Jul 1991, 3.3.3	Table XXII Plastic optical material tests—procedure.	S14.4.2.2.3.2 Cleaning.
SAE J576, Jul 1991, 3.4.1	Table XXII Plastic optical material tests—performance requirements.	S14.4.2.2.4.4 Luminous transmittance.
SAE J576, Jul 1991, 4.1	Table XXII Plastic optical material tests—samples.	S14.4.2.1.4 Color.
SAE J576, Jul 1991, 4.2	Table XXII Plastic optical material tests—performance requirements.	S14.4.2.2.4 Performance requirements.
SAE J576, Jul 1991, 4.2.1	Table XXII Plastic optical material tests—performance requirements.	S14.4.2.2.4.4 Luminous transmittance.
SAE J576, Jul 1991, 4.2.2	Table XXII Plastic optical material tests—performance requirements.	S14.4.2.2.4.5 Color test.
SAE J576, Jul 1991, 4.2.3	Table XXII Plastic optical material tests—performance requirements.	S14.4.2.2.4.2 Headlamps.
SAE J576, Jul 1991, 4.2.4	Table XXII Plastic optical material tests—performance requirements.	S14.4.2.2.4.3 Physical changes.
SAE J576, Jul 1991, 5	S6.8.4.1 UV tracer	S14.1.3 UV tracer.
SAE J577, Apr 1964, Figure 1	SAE J577, Apr 1964, Figure 1	Figure 21.
SAE J577, Apr 1964, Table 1	SAE J577, Apr 1964, Table 1	Figure 21.
SAE J578c, Feb 1977	Table XXII Color test	S14.4.1 Color test.
SAE J578c, Feb 1977, 2	S4 Definitions—Color	S4 Definitions—Color.
SAE J578c, Feb 1977, 2.1	Table XXII Color test—performance requirements.	S14.4.1.4.2 Performance requirements.
SAE J578c, Feb 1977, 2.1	Table XXII Color test—performance requirements.	S14.4.1.4.2.1 Red.
SAE J578c, Feb 1977, 2.2	Table XXII Color test—performance requirements.	S14.4.1.4.2 Performance requirements.
SAE J578c, Feb 1977, 2.2	Table XXII Color test—performance requirements.	S14.4.1.4.2.2 Yellow (Amber).
SAE J578c, Feb 1977, 2.3	Table XXII Color test—performance requirements.	S14.4.1.4.2 Performance requirements.
SAE J578c, Feb 1977, 2.3	Table XXII Color test—performance requirements.	S14.4.1.4.2.3 White.
SAE J578c, Feb 1977, 3	Table XXII Color test	S14.4.1.2.1 Design voltage.
SAE J578c, Feb 1977, 3	Table XXII Color test	S14.4.1.2.2 Components.
SAE J578c, Feb 1977, 3.1	Table XXII Color test—performance requirements.	S14.4.1.3.2 Performance requirements.
SAE J578c, Feb 1977, 3.1	Table XXII Color test—performance requirements.	S14.4.1.3.2.1 Red.
SAE J578c, Feb 1977, 3.1	Table XXII Color test—performance requirements.	S14.4.1.3.2.2 Yellow (Amber).
SAE J578c, Feb 1977, 3.1	Table XXII Color test—performance requirements.	S14.4.1.3.2.3 White.
SAE J578c, Feb 1977, 3.1	Table XXII Color test—procedure	S14.4.1.3 Visual method.
SAE J578c, Feb 1977, 3.1	Table XXII Color test—procedure	S14.4.1.3.1 Procedure.
SAE J578c, Feb 1977, 3.2	Table XXII Color test—procedure	S14.4.1.4 Tristimulus method.
SAE J578c, Feb 1977, 3.2	Table XXII Color test—procedure	S14.4.1.4.1 Procedure.
SAE J578c, Feb 1977, 3.2	Table XXII Color test—procedure	S14.4.1.4.1.1 Receiver spectral response.
SAE J578c, Feb 1977, 3.2	Table XXII Color test—procedure	S14.4.1.4.1.2 Integrating sphere.
SAE J578c, Feb 1977, 3.2	Table XXII Color test—procedure	S14.4.1.4.1.3 Non uniform color.
SAE J578c, Feb 1977, A2(b)	Table XXII Color test	S14.4.1.2.3 Operating temperature.
SAE J578c, Feb 1977, A2(c)	Table XXII Color test	S14.4.1.2.5 Test distance.

APPENDIX A.—FMVSS NO. 108 REWRITE CROSS REFERENCE—Continued

Current FMVSS No. 108 or incorporated document citation	FMVSS No. 108 rewrite NPRM citation	FMVSS No. 108 rewrite final rule citation
SAE J578c, Feb 1977, A2(d)	Table XXII Color test	S14.4.1.2.4 Visible surface.
SAE J578c, Feb 1977, Figure 1	Figure 1	Figure 1.
SAE J580, Dec 1986, 2.1	S4 Definitions—Sealed beam headlamp assembly.	S4 Definitions—Sealed beam headlamp assembly.
SAE J580, Dec 1986, 2.2	S4 Definitions—Mounting ring	S4 Definitions—Mounting ring.
SAE J580, Dec 1986, 2.3	S4 Definitions—Retaining ring	S4 Definitions—Retaining ring.
SAE J580, Dec 1986, 2.4	S4 Definitions—Aiming screws	S4 Definitions—Aiming screws.
SAE J580, Dec 1986, 4.1.2	S9.4 Physical tests	S10.13.4.1 Corrosion.
SAE J580, Dec 1986, 4.1.2	Table XXIII Corrosion test	S14.6.3 Corrosion test.
SAE J580, Dec 1986, 4.2	S10.7 Physical tests	S10.14.7.1 Aiming adjustment tests.
SAE J580, Dec 1986, 4.2	S11.7 Physical tests	S10.15.7.1 Aiming adjustment tests.
SAE J580, Dec 1986, 4.2	S9.4 Physical tests	S10.13.4.1 Aiming adjustment test.
SAE J580, Dec 1986, 4.2	Table XXIII Aiming adjustment test laboratory—procedure.	S14.6.17.1 Procedure.
SAE J580, Dec 1986, 4.2	Table XXIII Aiming adjustment test on vehicle—procedure.	S14.6.18.1 Procedure.
SAE J580, Dec 1986, 4.2	Table XXIII Aiming adjustment test on vehicle—procedure.	S14.6.18.1.1 Setup.
SAE J580, Dec 1986, 4.2	Table XXIII Aiming adjustment test on vehicle—procedure.	S14.6.18.1.3 Adjustments.
SAE J580, Dec 1986, 4.3	S10.7 Physical tests	S10.14.7.1 Inward force test.
SAE J580, Dec 1986, 4.3	S11.7 Physical tests	S10.15.7.1 Inward force test.
SAE J580, Dec 1986, 4.3	S9.4 Physical tests	S10.13.4.1 Inward force test.
SAE J580, Dec 1986, 4.3	Table XXIII Inward force test—procedure	S14.6.12.1 Procedure.
SAE J580, Dec 1986, 4.4	S10.7 Physical tests	S10.14.7.1 Connector test.
SAE J580, Dec 1986, 4.4	S10.7 Physical tests	S10.14.7.2 Connector—corrosion test.
SAE J580, Dec 1986, 4.4	S11.7 Physical tests	S10.15.7.1 Connector test.
SAE J580, Dec 1986, 4.4	S11.7 Physical tests	S10.15.7.1 Corrosion—connector test.
SAE J580, Dec 1986, 4.4	S9.4 Physical tests	S10.13.4.1 Connector test.
SAE J580, Dec 1986, 4.4	Table XXIII Headlamp connector test—procedure.	S14.6.15.1 Procedure.
SAE J580, Dec 1986, 4.5	S9.4 Physical tests	S10.13.4.1 Torque deflection test.
SAE J580, Dec 1986, 5.1.1.2	Table XXIII Corrosion test	S14.6.3 Corrosion test.
SAE J580, Dec 1986, 5.1.2.1	Table XXIII Aiming adjustment test laboratory—performance requirements.	S14.6.17.2.1 Sealed beam except Type F.
SAE J580, Dec 1986, 5.1.2.1	Table XXIII Aiming adjustment test laboratory—performance requirements.	S14.6.17.2.2 Type F, replaceable bulb, integral beam, and combination.
SAE J580, Dec 1986, 5.1.2.2	Table XXIII Aiming adjustment test laboratory—performance requirements.	S14.6.17.2.1 Sealed beam except Type F.
SAE J580, Dec 1986, 5.1.2.2	Table XXIII Aiming adjustment test laboratory—performance requirements.	S14.6.17.2.2 Type F, replaceable bulb, integral beam, and combination.
SAE J580, Dec 1986, 5.1.3	Table XXIII Inward force test—performance requirements.	S14.6.12.2 Performance requirements.
SAE J580, Dec 1986, 5.1.4	Table XXIII Headlamp connector test—performance requirements.	S14.6.15.2 Performance requirements.
SAE J580, Dec 1986, 5.1.5	Table XXIII Torque deflection test—performance requirements.	S14.6.13.2 Performance requirements.
SAE J580, Dec 1986, 5.1.6	S9.4 Physical tests	S10.13.4.2 Retaining ring test ex types G & H.
SAE J580, Dec 1986, 5.1.6	Table XXIII Retaining ring test	S14.6.14 Retaining ring test.
SAE J580, Dec 1986, 5.1.6	Table XXIII Retaining ring test—performance requirements.	S14.6.14.2 Performance requirements.
SAE J580, Dec 1986, 5.1.6	Table XXIII Retaining ring test—procedure	S14.6.14.1 Procedure.
SAE J580, Dec 1986, Figure 1	Figure 4	Figure 4.
SAE J580, Dec 1986, Figure 1	Table XXIII Headlamp connector test	S14.6.15 Headlamp connector test.
SAE J580, Dec 1986, Figure 2	Figure 18	Figure 18.
SAE J580, Dec 1986, Figure 3	Figure 16	Figure 16.
SAE J580, Dec 1986, Figure 4	Figure 17	Figure 17.
SAE J584, Apr 1964	S13.3 Physical tests	S10.17.4 Physical tests.
SAE J584, Apr 1964	S4 Definitions—Motor driven cycle	S4 Definitions—Motor driven cycle.
SAE J584, Apr 1964	S4 Definitions—Motorcycle or motor driven cycle headlamp.	S4 Definitions—Motorcycle or motor driven cycle headlamp.
SAE J584, Apr 1964	S6.8.5.6.2(j) Aiming—Motorcycle LB	S14.2.5.5.9 Motorcycle headlamp—lower beam headlamps designed to comply with Table XX.
SAE J584, Oct 1993	S6.8.5.6.2(i) Aiming—Motorcycle UB	S14.2.5.5.8 Motorcycle headlamp—upper beam headlamps designed to comply with Table XX.
SAE J585e, Sep 1977, 2.1	S4 Definitions—Taillamps	S4 Definitions—Taillamps.
SAE J585e, Sep 1977, 3	S7.2.2 Physical tests	S7.2.14 Physical tests.

APPENDIX A.—FMVSS NO. 108 REWRITE CROSS REFERENCE—Continued

Current FMVSS No. 108 or incorporated document citation	FMVSS No. 108 rewrite NPRM citation	FMVSS No. 108 rewrite final rule citation
SAE J585e, Sep 1977, 3.1	S7.2.1.1 Multiple compartments and multiple lamps.	S7.2.11 Multiple compartments and multiple lamps.
SAE J585e, Sep 1977, 3.1	S7.2.1.1 Multiple compartments and multiple lamps.	S7.2.11.1.
SAE J585e, Sep 1977, 3.1	S7.2.1.1 Multiple compartments and multiple lamps.	S7.2.11.2.
SAE J585e, Sep 1977, 3.1	S7.2.1.1 Multiple compartments and multiple lamps.	S7.2.11.3.
SAE J585e, Sep 1977, 3.1	S7.2.1.1.1 Lamps installed on vehicles 2032 mm or more in overall width.	S7.2.11.4 Taillamps installed on vehicles 2032 mm. or more in overall width.
SAE J585e, Sep 1977, 3.6.2	S6.8.5.1.2 Multiple compartment & multiple lamp photometry.	S14.2.1.5.1 All photometered together.
SAE J585e, Sep 1977, 3.6.2(a)	S6.8.5.1.2.1 Photometry of all compartments/lamps together.	S14.2.1.5.2(a) Measuring together.
SAE J585e, Sep 1977, 3.6.2(b)	S6.8.5.1.2.2 Photometry of individual compartments/lamps.	S14.2.1.5.2(b) Measuring individually.
SAE J585e, Sep 1977, 4	Table V SAE taillamp visibility	Table V—b SAE taillamp visibility.
SAE J585e, Sep 1977, Table 1, footnote 5	Omitted.	Table VIII footnote 4.
SAE J586, Feb 1984, 2.1	S4 Definitions—Stop lamps	S4 Definitions—Stop lamps.
SAE J586, Feb 1984, 4.1.5.2	S6.8.5.1.2 Multiple compartment & multiple lamp photometry.	S14.2.1.5.1 All photometered together.
SAE J586, Feb 1984, 4.1.5.2.1	S6.8.5.1.2.1 Photometry of all compartments/lamps together.	S14.2.1.5.2(a) Measuring together.
SAE J586, Feb 1984, 4.1.5.2.2	S6.8.5.1.2.2 Photometry of individual compartments/lamps.	S14.2.1.5.2(b) Measuring individually.
SAE J586, Feb 1984, 5	S7.3.2 Physical tests	S7.3.14 Physical tests.
SAE J586, Feb 1984, 5.1.5.2	S7.3.1.1 Multiple compartments and multiple lamps.	S7.3.11 Multiple compartments and multiple lamps.
SAE J586, Feb 1984, 5.1.5.2	S7.3.1.1 Multiple compartments and multiple lamps.	S7.3.11.1.
SAE J586, Feb 1984, 5.1.5.2	S7.3.1.1 Multiple compartments and multiple lamps.	S7.3.11.2.
SAE J586, Feb 1984, 5.1.5.2	S7.3.1.1 Multiple compartments and multiple lamps.	S7.3.11.3.
SAE J586, Feb 1984, 5.1.5.3	S7.3.1.2 Ratio to taillamps	S7.3.12 Ratio to taillamps.
SAE J586, Feb 1984, 5.1.5.3	S7.3.1.2 Ratio to taillamps	S7.3.12.1.
SAE J586, Feb 1984, 5.1.5.3	S7.3.1.2 Ratio to taillamps	S7.3.12.2.
SAE J586, Feb 1984, 5.1.5.3	S7.3.1.2 Ratio to taillamps	S7.3.12.3.
SAE J586, Feb 1984, 5.1.5.3	S7.3.1.2 Ratio to taillamps	S7.3.12.4.
SAE J586, Feb 1984, 5.1.5.3	Table IX footnote 6	Table IX footnote 6.
SAE J586, Feb 1984, 5.1.5.3	Table IX footnote 7	Table IX footnote 5.
SAE J586, Feb 1984, 5.1.5.3	Table IX footnote 7	Table XIII—a footnote 5, Table XIII—b, footnote 4.
SAE J586, Feb 1984, 5.1.5.3	Table IX Stop lamp—Photometric ratio	Table IX Stop lamp—Photometric ratio.
SAE J586, Feb 1984, 5.1.5.3	Table IX Stop lamp—Photometric ratio	Table XIII—b Motorcycle stop lamp—Photometric ratio.
SAE J586, Feb 1984, 5.3.1	S7.3.3 Combined lamp bulb indexing	S7.3.15 Combined lamp bulb indexing.
SAE J586, Feb 1984, 5.3.1	S7.3.3 Combined lamp bulb indexing	S7.3.15.1 Dual filament bulbs.
SAE J586, Feb 1984, 5.3.1	S7.3.3 Combined lamp bulb indexing	S7.3.15.2 Socket indexing.
SAE J586, Feb 1984, 5.4.1	Table V SAE stop lamp visibility	Table V—b SAE stop lamp visibility.
SAE J586, Feb 1984, Table 1	S7.3.1 Photometry	S7.3.13 Photometry.
SAE J586, Feb 1984, Table 1	S7.3.1 Photometry	S7.3.13.1.
SAE J586, Feb 1984, Table 1	Table IX Stop lamp—Individual point photometry.	Table IX Stop lamp—Individual point photometry.
SAE J586, Feb 1984, Table 1	Table IX Stop lamp—Zone photometry	Table IX Stop lamp—Group photometry.
SAE J586, Feb 1984, Table 1, footnote a	Standard note—new table	Table XIII—a footnote 1.
SAE J586, Feb 1984, Table 1, footnote a	Table IX footnote 1	Table IX footnote 1.
SAE J586, Feb 1984, Table 1, footnote b	Standard note—new table	Table XIII—a footnote 3, Table XIII—b footnote 1.
SAE J586, Feb 1984, Table 1, footnote b	Table IX footnote 3	Table IX footnote 3.
SAE J587, Oct 1981, 2	S4 Definitions—License plate lamps	S4 Definitions—License plate lamps.
SAE J587, Oct 1981, 3	S7.7.3 Physical tests	S7.7.14 Physical tests.
SAE J587, Oct 1981, 4	S7.7.3 Physical tests	S7.7.14 Physical tests.
SAE J587, Oct 1981, 5	S7.7.3 Physical tests	S7.7.14 Physical tests.
SAE J587, Oct 1981, 6.1	S6.6.1 License plate holder	S6.6.3 License plate holder.
SAE J587, Oct 1981, 6.2	S6.6.1 License plate holder	S6.6.3 License plate holder.
SAE J587, Oct 1981, 6.3	S6.8.5.3 License plate lamp photometry	S14.2.2 License plate lamp photometry.
SAE J587, Oct 1981, 6.3	S7.7.1 Installation	S7.7.15.1.
SAE J587, Oct 1981, 6.3	S7.7.1 Installation	S7.7.15.2.
SAE J587, Oct 1981, 6.3	S7.7.1 Installation	S7.7.15.3.
SAE J587, Oct 1981, 6.4	S6.1.4 License plate lamp	S6.1.3.3 License plate lamp.

APPENDIX A.—FMVSS NO. 108 REWRITE CROSS REFERENCE—Continued

Current FMVSS No. 108 or incorporated document citation	FMVSS No. 108 rewrite NPRM citation	FMVSS No. 108 rewrite final rule citation
SAE J587, Oct 1981, 6.5	S7.7.1.1 Incident light from a single lamp	S7.7.15.4 Incident light from a single lamp.
SAE J587, Oct 1981, 6.6	S7.7.1.2 Incident light from multiple lamps	S7.7.15.5 Incident light from multiple lamps.
SAE J587, Oct 1981, 6.7	S6.8.5.3.1 Illumination surface	S14.2.2.1 Illumination surface.
SAE J587, Oct 1981, 6.8	S6.8.5.3.2 Test stations	S14.2.2.2 Test stations.
SAE J587, Oct 1981, 7	S7.7.2 Photometry requirements	S7.7.13 Photometry.
SAE J587, Oct 1981, 7	S7.7.2 Photometry requirements	S7.7.13 Ratio—motorcycles and motor driven cycles.
SAE J587, Oct 1981, 7	S7.7.2 Photometry requirements	S7.7.13.1.
SAE J587, Oct 1981, 7	S7.7.2 Photometry requirements	S7.7.13.2 Illumination.
SAE J587, Oct 1981, 7	S7.7.2 Photometry requirements	S7.7.13.3 Ratio except motorcycles and motor driven cycles.
SAE J587, Oct 1981, Figure 1	Table XIII	Figure 19.
SAE J587, Oct 1981, Figure 2	Table XIII	Figure 19.
SAE J587, Oct 1981, Figure 3	Not included	Figure 20.
SAE J588, Nov 1984, 2.1	S4 Definitions—Turn signal lamps	S4 Definitions—Turn signal lamps.
SAE J588, Nov 1984, 4	S7.1.3 Physical tests	S7.1.1.14 Physical tests.
SAE J588, Nov 1984, 4	S7.1.3 Physical tests	S7.1.2.14 Physical tests.
SAE J588, Nov 1984, 4.1.5.2	S6.8.5.1.2 Multiple compartment & multiple lamp photometry.	S14.2.1.5.1 All photometered together.
SAE J588, Nov 1984, 4.1.5.2.1	S6.8.5.1.2.1 Photometry of all compartments/lamps together.	S14.2.1.5.2(a) Measuring together.
SAE J588, Nov 1984, 4.1.5.2.2	S6.8.5.1.2.2 Photometry of individual compartments/lamps.	S14.2.1.5.2(b) Measuring individually.
SAE J588, Nov 1984, 5.1.5.2	S7.1.1.3 Multiple compartments and multiple lamps.	S7.1.1.11 Multiple compartments and multiple lamps.
SAE J588, Nov 1984, 5.1.5.2	S7.1.1.3 Multiple compartments and multiple lamps.	S7.1.1.11.1.
SAE J588, Nov 1984, 5.1.5.2	S7.1.1.3 Multiple compartments and multiple lamps.	S7.1.1.11.2.
SAE J588, Nov 1984, 5.1.5.2	S7.1.1.3 Multiple compartments and multiple lamps.	S7.1.1.11.3.
SAE J588, Nov 1984, 5.1.5.2	S7.1.2.2 Multiple compartments and multiple lamps.	S7.1.2.11 Multiple compartments and multiple lamps.
SAE J588, Nov 1984, 5.1.5.2	S7.1.2.2 Multiple compartments and multiple lamps.	S7.1.2.11.1.
SAE J588, Nov 1984, 5.1.5.2	S7.1.2.2 Multiple compartments and multiple lamps.	S7.1.2.11.2.
SAE J588, Nov 1984, 5.1.5.2	S7.1.2.2 Multiple compartments and multiple lamps.	S7.1.2.11.3.
SAE J588, Nov 1984, 5.1.5.3	S7.1.1.3.2 Ratio to parking lamps and clearance lamps.	S7.1.1.12 Ratio to parking lamps and clearance lamps.
SAE J588, Nov 1984, 5.1.5.3	S7.1.1.3.2 Ratio to parking lamps and clearance lamps.	S7.1.1.12.1.
SAE J588, Nov 1984, 5.1.5.3	S7.1.1.3.2 Ratio to parking lamps and clearance lamps.	S7.1.1.12.2.
SAE J588, Nov 1984, 5.1.5.3	S7.1.1.3.2 Ratio to parking lamps and clearance lamps.	S7.1.1.12.3.
SAE J588, Nov 1984, 5.1.5.3	S7.1.1.3.2 Ratio to parking lamps and clearance lamps.	S7.1.1.12.4.
SAE J588, Nov 1984, 5.1.5.3	S7.1.2.3 Ratio to taillamps and clearance lamps.	S7.1.2.12 Ratio to taillamps and clearance lamps.
SAE J588, Nov 1984, 5.1.5.3	S7.1.2.3 Ratio to taillamps and clearance lamps.	S7.1.2.12.1.
SAE J588, Nov 1984, 5.1.5.3	S7.1.2.3 Ratio to taillamps and clearance lamps.	S7.1.2.12.2.
SAE J588, Nov 1984, 5.1.5.3	S7.1.2.3 Ratio to taillamps and clearance lamps.	S7.1.2.12.3.
SAE J588, Nov 1984, 5.1.5.3	S7.1.2.3 Ratio to taillamps and clearance lamps.	S7.1.2.12.4.
SAE J588, Nov 1984, 5.1.5.3	Table VI Front turn signal lamp—Photometric ratio.	Table VI Front turn signal lamp—Photometric ratio.
SAE J588, Nov 1984, 5.1.5.3	Table VII footnote 8	Table VII footnote 8.
SAE J588, Nov 1984, 5.1.5.3	Table VII Rear turn signal lamp—Photometric ratio.	Table VII Rear turn signal lamp—Photometric ratio.
SAE J588, Nov 1984, 5.1.5.4	S7.1.1.2 Spacing to other lamps	S7.1.1.10 Spacing to other lamps.
SAE J588, Nov 1984, 5.1.5.4	S7.1.1.2 Spacing to other lamps	S7.1.1.10.1.
SAE J588, Nov 1984, 5.1.5.4	Table VI Front turn signal lamp—1.5 × base individual point photometry.	Table VI—b Front turn signal lamp—1.5 × base individual point photometry.
SAE J588, Nov 1984, 5.1.5.4	Table VI Front turn signal lamp—1.5 × base zone photometry.	Table VI—b Front turn signal lamp—1.5 × base group photometry.

APPENDIX A.—FMVSS NO. 108 REWRITE CROSS REFERENCE—Continued

Current FMVSS No. 108 or incorporated document citation	FMVSS No. 108 rewrite NPRM citation	FMVSS No. 108 rewrite final rule citation
SAE J588, Nov 1984, 5.1.5.4	Table VI Front turn signal lamp—2 × base individual point photometry.	Table VI—b Front turn signal lamp—2 × base individual point photometry.
SAE J588, Nov 1984, 5.1.5.4	Table VI Front turn signal lamp—2 × base zone photometry.	Table VI—b Front turn signal lamp—2 × base group photometry.
SAE J588, Nov 1984, 5.1.5.4	Table VI Front turn signal lamp—2.5 × base individual point photometry.	Table VI—a Front turn signal lamp—2.5 × base individual point photometry.
SAE J588, Nov 1984, 5.1.5.4	Table VI Front turn signal lamp—2.5 × base zone photometry.	Table VI—a Front turn signal lamp—2.5 × base group photometry.
SAE J588, Nov 1984, 5.1.5.4.1	S7.1.1.2.1 Spacing measurement for non reflector lamps.	S7.1.1.10.2 Spacing measurement for non reflector lamps.
SAE J588, Nov 1984, 5.1.5.4.2	S7.1.1.2.2 Spacing measurement for lamps with reflectors.	S7.1.1.10.3 Spacing measurement for lamps with reflectors.
SAE J588, Nov 1984, 5.3.1	S7.1.4 Combined lamp bulb indexing	S7.1.3 Combined lamp bulb indexing.
SAE J588, Nov 1984, 5.3.1	S7.1.4 Combined lamp bulb indexing	S7.1.3.1 Dual filament bulbs.
SAE J588, Nov 1984, 5.3.1	S7.1.4 Combined lamp bulb indexing	S7.1.3.2 Socket indexing.
SAE J588, Nov 1984, 5.3.2	Table IV Front turn signal lamp—Effective projected luminous lens area.	Table IV—a Front turn signal lamp—Effective projected luminous lens area.
SAE J588, Nov 1984, 5.4.1	Table V SAE turn signal lamp visibility	Table V—b SAE turn signal lamp visibility.
SAE J588, Nov 1984, Table 1	S7.1.1.1 Photometry	S7.1.1.13 Photometry.
SAE J588, Nov 1984, Table 1	S7.1.1.1 Photometry	S7.1.1.13.1.
SAE J588, Nov 1984, Table 1	S7.1.1.1 Photometry	S7.1.1.13.2.
SAE J588, Nov 1984, Table 1	S7.1.2.1 Photometry	S7.1.2.13 Photometry.
SAE J588, Nov 1984, Table 1	S7.1.2.1 Photometry	S7.1.2.13.1.
SAE J588, Nov 1984, Table 1	Table VI Front turn signal lamp—Base zone photometry.	Table VI—a Front turn signal lamp—Base group photometry.
SAE J588, Nov 1984, Table 1	Table VII footnote 5	Table VII footnote 5.
SAE J588, Nov 1984, Table 1	Table VII Rear turn signal lamp—Amber lamp zone photometry.	Table VII Rear turn signal lamp—Amber lamp group photometry.
SAE J588, Nov 1984, Table 1	Table VII Rear turn signal lamp—Red lamp zone photometry.	Table VII Rear turn signal lamp—Red lamp group photometry.
SAE J588, Nov 1984, Table 1, footnote a	Standard note—new table	Table XIII—a footnote 1.
SAE J588, Nov 1984, Table 1, footnote a	Table VI footnote 1	Table VI footnote 1.
SAE J588, Nov 1984, Table 1, footnote a	Table VII footnote 1	Table VII footnote 1.
SAE J588, Nov 1984, Table 1, footnote b	Table VII footnote 4	Table VII footnote 4.
SAE J588, Nov 1984, Table 2	S7.1.1.2.3 Spacing based photometric multipliers.	S7.1.1.10.4 Spacing based photometric multipliers.
SAE J588, Nov 1984, Table 2	Table VI Front turn signal lamp—1.5 × base individual point photometry.	Table VI—b Front turn signal lamp—1.5 × base individual point photometry.
SAE J588, Nov 1984, Table 2	Table VI Front turn signal lamp—2 × base individual point photometry.	Table VI—b Front turn signal lamp—2 × base individual point photometry.
SAE J588, Nov 1984, Table 2	Table VI Front turn signal lamp—2 × base zone photometry.	Table VI—b Front turn signal lamp—2 × base group photometry.
SAE J588, Nov 1984, Table 2	Table VI Front turn signal lamp—2.5 × base individual point photometry.	Table VI—a Front turn signal lamp—2.5 × base individual point photometry.
SAE J588, Nov 1984, Table 2	Table VI Front turn signal lamp—2.5 × base zone photometry.	Table VI—a Front turn signal lamp—2.5 × base group photometry.
SAE J588, Nov 1984, Table 2	Table VI Front turn signal lamp—1.5 × base zone photometry.	Table VI—b Front turn signal lamp—1.5 × base group photometry.
SAE J588, Nov 1984, Table 3	Table VI Front turn signal lamp—Base individual point photometry.	Table VI—a Front turn signal lamp—Base individual point photometry.
SAE J588, Nov 1984, Table 3	Table VII Rear turn signal lamp—Amber lamp individual point photometry.	Table VII Rear turn signal lamp—Amber lamp individual point photometry.
SAE J588, Nov 1984, Table 3	Table VII Rear turn signal lamp—Red lamp individual point photometry.	Table VII Rear turn signal lamp—Red lamp individual point photometry.
SAE J588e, Sep 1970	S7.14.3 Turn signal pilot indicator	S9.3 Turn signal pilot indicator.
SAE J588e, Sep 1970	S7.14.3 Turn signal pilot indicator	S9.3.1 TS lamps not visible.
SAE J588e, Sep 1970	S7.14.3 Turn signal pilot indicator	S9.3.2 Indicator light(s).
SAE J588e, Sep 1970	S7.14.3 Turn signal pilot indicator	S9.3.3 Function.
SAE J588e, Sep 1970	S7.14.3.1 Indicator size and color	S9.3.4 Indicator size and color.
SAE J588e, Sep 1970	S7.14.3.1 Indicator size and color	S9.3.4.1 Interior mounted.
SAE J588e, Sep 1970	S7.14.3.1 Indicator size and color	S9.3.4.2 Exterior mounted.
SAE J588e, Sep 1970	S7.14.3.1 Indicator size and color	S9.3.5 Visibility.
SAE J588e, Sep 1970, 3.4	SAE J588e, Sep 1970, 3.4	S6.1.1.3.1.
SAE J588e, Sep 1970, 3.9.1	SAE J588e, Sep 1970, 3.9.1	S6.1.1.3.
SAE J588e, Sep 1970, 3.9.1	Table VII footnote 6	Table VII footnote 6.
SAE J589, Apr 1964	S4 Definitions—Turn signal operating unit	S4 Definitions—Turn signal operating unit.
SAE J589, Apr 1964	Table XXI	S9.1.2 Physical tests.
SAE J589, Apr 1964	Table XXI Turn signal operating unit durability test.	S14.9.1 Turn Signal operating unit durability test.
SAE J589, Apr 1964	Table XXI Turn signal operating unit durability test—performance requirements.	S14.9.1.3 Performance requirements.

APPENDIX A.—FMVSS NO. 108 REWRITE CROSS REFERENCE—Continued

Current FMVSS No. 108 or incorporated document citation	FMVSS No. 108 rewrite NPRM citation	FMVSS No. 108 rewrite final rule citation
SAE J589, Apr 1964	Table XXI Turn signal operating unit durability test—performance requirements.	S14.9.1.3.2 Voltage drop (2032 mm or wider).
SAE J589, Apr 1964	Table XXI Turn signal operating unit durability test—performance requirements.	S14.9.1.3.3 Stop contacts.
SAE J589, Apr 1964	Table XXI Turn signal operating unit durability test—procedure.	S14.9.1.1 Power supply specifications.
SAE J589, Apr 1964	Table XXI Turn signal operating unit durability test—procedure.	S14.9.1.2 Procedure.
SAE J589, Apr 1964	Table XXI Turn signal operating unit durability test—procedure.	S14.9.1.2.1 Circuit.
SAE J589, Apr 1964	Table XXI Turn signal operating unit durability test—procedure.	S14.9.1.2.2 Cycle.
SAE J589, Apr 1964	Table XXI Turn signal operating unit durability test—procedure.	S14.9.1.2.3 Voltage drop.
SAE J590b, Oct 1965	S4 Definitions—Turn signal flasher	S4 Definitions—Turn signal flasher.
SAE J590b, Oct 1965	S7.14.2 Turn signal flasher	S9.2.1 Indicator signals.
SAE J590b, Oct 1965	Table XXI	S9.2.2 Physical tests.
SAE J590b, Oct 1965	Table XXI Turn signal flasher and vehicular hazard warning signal flasher tests.	S14.9.3 Turn signal flasher and vehicular hazard warning signal warning flasher tests.
SAE J590b, Oct 1965	Table XXI Turn signal flasher durability test	S14.9.3.6 Turn signal flasher durability test.
SAE J590b, Oct 1965	Table XXI Turn signal flasher durability test—performance requirements.	S14.9.3.6.3 Performance requirements.
SAE J590b, Oct 1965	Table XXI Turn signal flasher durability test—procedure.	S14.9.3.6.1 Samples.
SAE J590b, Oct 1965	Table XXI Turn signal flasher durability test—procedure.	S14.9.3.6.2 Procedure.
SAE J590b, Oct 1965	Table XXI Turn signal flasher durability test—procedure.	S14.9.3.6.2.1 Setup.
SAE J590b, Oct 1965	Table XXI Turn signal flasher durability test—procedure.	S14.9.3.6.2.2 Temperature and voltage.
SAE J590b, Oct 1965	Table XXI Turn signal flasher durability test—procedure.	S14.9.3.6.2.3 Duration.
SAE J590b, Oct 1965	Table XXI Turn signal flasher flash rate and percent current “on” time test.	S14.9.3.5 Turn signal flasher flash rate and percent current “on” time test.
SAE J590b, Oct 1965	Table XXI Turn signal flasher starting time test—procedure.	S14.9.3.3.1 Samples.
SAE J590b, Oct 1965	Table XXI Turn signal flasher voltage drop test.	S14.9.3.4 Turn signal flasher voltage drop test.
SAE J590b, Oct 1965	Table XXI Turn signal flasher voltage drop test—performance requirements.	S14.9.3.4.3 Performance requirements.
SAE J590b, Oct 1965	Table XXI Turn signal flasher voltage drop test—procedure.	S14.9.3.4.1 Samples.
SAE J590b, Oct 1965, 1	Table XXI Turn signal flasher starting time test.	S14.9.3.3 Turn signal flasher starting time test.
SAE J590b, Oct 1965, 1	Table XXI Turn signal flasher starting time test—performance requirements.	S14.9.3.3.3 Performance requirements.
SAE J590b, Oct 1965, 1	Table XXI Turn signal flasher starting time test—performance requirements.	S14.9.3.3.3(a) Normally closed contacts.
SAE J590b, Oct 1965, 1	Table XXI Turn signal flasher starting time test—performance requirements.	S14.9.3.3.3(b) Normally open contacts.
SAE J590b, Oct 1965, 1	Table XXI Turn signal flasher starting time test—procedure.	S14.9.3.3.2 Procedure.
SAE J590b, Oct 1965, 1	Table XXI Turn signal flasher starting time test—procedure.	S14.9.3.3.2.1 Setup.
SAE J590b, Oct 1965, 1	Table XXI Turn signal flasher starting time test—procedure.	S14.9.3.3.2.2 Measurement.
SAE J590b, Oct 1965, 2	Table XXI Turn signal flasher voltage drop test—procedure.	S14.9.3.4.2 Procedure.
SAE J590b, Oct 1965, 2	Table XXI Turn signal flasher voltage drop test—procedure.	S14.9.3.4.2.1 Setup.
SAE J590b, Oct 1965, 2	Table XXI Turn signal flasher voltage drop test—procedure.	S14.9.3.4.2.2 Measurement.
SAE J590b, Oct 1965, 3	Table XXI Turn signal flasher flash rate and percent current “on” time test—performance requirements.	S14.9.3.5.3 Performance requirements.
SAE J590b, Oct 1965, 3	Table XXI Turn signal flasher flash rate and percent current “on” time test—performance requirements.	S14.9.3.5.3(a) Normally closed contacts.
SAE J590b, Oct 1965, 3	Table XXI Turn signal flasher flash rate and percent current “on” time test—performance requirements.	S14.9.3.5.3(b) Normally open contacts.

APPENDIX A.—FMVSS NO. 108 REWRITE CROSS REFERENCE—Continued

Current FMVSS No. 108 or incorporated document citation	FMVSS No. 108 rewrite NPRM citation	FMVSS No. 108 rewrite final rule citation
SAE J590b, Oct 1965, 3	Table XXI Turn signal flasher flash rate and percent current "on" time test—procedure.	S14.9.3.5.1 Samples.
SAE J590b, Oct 1965, 3	Table XXI Turn signal flasher flash rate and percent current "on" time test—procedure.	S14.9.3.5.2 Procedure.
SAE J590b, Oct 1965, 3	Table XXI Turn signal flasher flash rate and percent current "on" time test—procedure.	S14.9.3.5.2.1 Setup.
SAE J590b, Oct 1965, 3	Table XXI Turn signal flasher flash rate and percent current "on" time test—procedure.	S14.9.3.5.2.2 Temperature and voltage.
SAE J590b, Oct 1965, 3	Table XXI Turn signal flasher flash rate and percent current "on" time test—procedure.	S14.9.3.5.2.3 Measurement.
SAE J590b, Oct 1965, Figure 1	Figure 2	Figure 2.
SAE J592e, Jul 1972, 2.1	S4 Definitions—Clearance lamps	S4 Definitions—Clearance lamps.
SAE J592e, Jul 1972, 2.2	S4 Definitions—Side marker lamps	S4 Definitions—Side marker lamps.
SAE J592e, Jul 1972, 2.3	S4 Definitions—Combination clearance and side marker lamps.	S4 Definitions—Combination clearance and side marker lamps.
SAE J592e, Jul 1972, 2.4	S4 Definitions—Identification lamps	S4 Definitions—Identification lamps.
SAE J592e, Jul 1972, 3	S7.4.2 Physical tests	S7.4.14 Physical tests.
SAE J592e, Jul 1972, 3	S7.5.2 Physical tests	S7.5.14 Physical tests.
SAE J592e, Jul 1972, Table 1	S7.4.1 Photometry	S7.4.13 Photometry.
SAE J592e, Jul 1972, Table 1	S7.4.1 Photometry	S7.4.13.1.
SAE J592e, Jul 1972, Table 1	S7.5.1 Photometry	S7.5.13 Photometry.
SAE J592e, Jul 1972, Table 1	Table X Amber side marker lamp photometry	Table X Amber side marker lamp photometry.
SAE J592e, Jul 1972, Table 1	Table X Red side marker lamp photometry	Table X Red side marker lamp photometry.
SAE J592e, Jul 1972, Table 1	Table XI Amber clearance and identification lamp photometry.	Table XI Amber clearance and identification lamp photometry.
SAE J592e, Jul 1972, Table 1	Table XI Red clearance and identification lamp photometry.	Table XI Red clearance and identification lamp photometry.
SAE J592e, Jul 1972, Table 1, footnote a	Table XI footnote 3	Table XI footnote 3.
SAE J592e, Jul 1972, Table 1, footnote b	S7.4.1.1 Inboard photometry	S7.4.13.2 Inboard photometry.
SAE J592e, Jul 1972, Table 1, footnote b	Table X footnote 1	Table X footnote 1.
SAE J593c, Feb 1968	S4 Definitions—Backup lamp	S4 Definitions—Backup lamp.
SAE J593c, Feb 1968	S7.6.2 Color	S7.6.2.2 Incidental light.
SAE J593c, Feb 1968	S7.6.3 Physical tests	S7.6.14 Physical tests.
SAE J593c, Feb 1968	Table I Activation—Backup lamps	Table I—a Activation—Backup lamps.
SAE J593c, Feb 1968, Table 1, footnote a	Table XII Single backup lamp system—Individual point photometry.	Table XII Single lamp system—Individual point photometry.
SAE J593c, Feb 1968, Table 1, footnote b	Table XII Two backup lamp system—Individual point photometry.	Table XII Two lamp systems Each lamp—Individual point photometry.
SAE J593c, Feb 1968, Table 1, footnote c	Table XII Backup lamp—Maximum photometric intensity.	Table XII Backup lamp—Maximum photometric intensity any single lamp.
SAE J594f, Jan 1977, 2	S4 Definitions—Reflex reflectors	S4 Definitions—Reflex reflectors.
SAE J594f, Jan 1977, 3	S7.10.2 Physical tests	S8.1.12 Physical tests.
SAE J594f, Jan 1977, 3.1.7	S6.8.5.4 Reflex reflector photometry	S14.2.3 Reflex reflector and retroreflective sheeting photometry.
SAE J594f, Jan 1977, 3.1.7	S6.8.5.4 Reflex reflector photometry	S14.2.3.1 Mounting.
SAE J594f, Jan 1977, 3.1.7	S6.8.5.4 Reflex reflector photometry	S14.2.3.2 Illumination source.
SAE J594f, Jan 1977, 3.1.7	S6.8.5.4 Reflex reflector photometry	S14.2.3.3 Measurement distance.
SAE J594f, Jan 1977, 3.1.7	S6.8.5.4 Reflex reflector photometry	S14.2.3.4 Test setup.
SAE J594f, Jan 1977, 3.1.7	S6.8.5.4 Reflex reflector photometry	S14.2.3.5 Photodetector.
SAE J594f, Jan 1977, 3.1.7	S6.8.5.4 Reflex reflector photometry	S14.2.3.6 Photometry surface.
SAE J594f, Jan 1977, 3.1.7	S6.8.5.4.1 Reflex reflector and retroreflective sheeting photometry measurements.	S14.2.3.7 Procedure.
SAE J594f, Jan 1977, 3.1.7	S6.8.5.4.1 Reflex reflector and retroreflective sheeting photometry measurements.	S14.2.3.7.1 Observation angle.
SAE J594f, Jan 1977, 3.1.7	S6.8.5.4.1 Reflex reflector and retroreflective sheeting photometry measurements.	S14.2.3.7.2 Entrance angle.
SAE J594f, Jan 1977, 3.1.7	S6.8.5.4.1 Reflex reflector and retroreflective sheeting photometry measurements.	S14.2.3.7.3 Convention.
SAE J594f, Jan 1977, 3.1.7	S6.8.5.4.1 Reflex reflector and retroreflective sheeting photometry measurements.	S14.2.3.7.4 Luminous intensity and illumination.
SAE J594f, Jan 1977, 3.1.7	S6.8.5.4.1 Reflex reflector and retroreflective sheeting photometry measurements.	S14.2.3.8 Measurements.
SAE J594f, Jan 1977, 3.1.7	S6.8.5.4.1.1 Reflex reflector photometry measurement adjustments.	S14.2.3.8.3 Reflex reflector photometry measurement adjustments.
SAE J594f, Jan 1977, 3.1.7	S6.8.5.4.1.1 Reflex reflector photometry measurement adjustments.	S14.2.3.8.3.1 Reflectors with non fixed rotation.
SAE J594f, Jan 1977, 3.1.7	S6.8.5.4.1.1 Reflex reflector photometry measurement adjustments.	S14.2.3.8.3.2 Reflectors with fixed rotation.
SAE J594f, Jan 1977, 3.1.7	S6.8.5.4.1.1 Reflex reflector photometry measurement adjustments.	S14.2.3.8.3.3 Additional photometric readings.
SAE J594f, Jan 1977, 3.1.8	S6.8.2 Samples for test	S14.4.1.1 Samples.

APPENDIX A.—FMVSS NO. 108 REWRITE CROSS REFERENCE—Continued

Current FMVSS No. 108 or incorporated document citation	FMVSS No. 108 rewrite NPRM citation	FMVSS No. 108 rewrite final rule citation
SAE J594f, Jan 1977, Table 1	S7.10.1 Photometry	S8.1.11 Photometry.
SAE J594f, Jan 1977, Table 1	S7.10.1.1 Alternative side reflex reflectors	S8.1.13 Alternative side reflex reflector material.
SAE J594f, Jan 1977, Table 1	Table XVI Red reflex reflector photometry	Table XVI—a Red reflex reflector photometry.
SAE J594f, Jan 1977, Table 1, footnote a	Table XVI White reflex reflector photometry	Table XVI—a White reflex reflector photometry.
SAE J594f, Jan 1977, Table 1, footnote a	Table XVI Amber reflex reflector photometry	Table XVI—a Amber reflex reflector photometry.
SAE J594f, Jan 1977, Table 1A	S7.10.1 Photometry	S8.1.11 Photometry.
SAE J594f, Jan 1977, Table 1A	S7.10.1.1 Alternative side reflex reflectors	S8.1.13 Alternative side reflex reflector material.
SAE J594f, Jan 1977, Table 1A	Table XVI Red reflex reflector photometry	Table XVI—a Red reflex reflector photometry.
SAE J594f, Jan 1977, Table 1A, footnote a	Table XVI Amber reflex reflector photometry	Table XVI—a Amber reflex reflector photometry.
SAE J594f, Jan 1977, Table 1A, footnote a	Table XVI White reflex reflector photometry	Table XVI—a White reflex reflector photometry.
SAE J823b, Apr 1968	SAE J823b, Apr 1968	S14.9.3.1 Standard test circuit.
SAE J823b, Apr 1968	SAE J823b, Apr 1968	S14.9.3.1.1 Test circuit setup.
SAE J823b, Apr 1968, 4	SAE J823b, Apr 1968, 4	S14.9.3.1.1.1 Series resistance.
SAE J823b, Apr 1968, 5	SAE J823b, Apr 1968, 5	S14.9.3.1.1.2 A–B resistance.
SAE J823b, Apr 1968, 6	SAE J823b, Apr 1968, 6	S14.9.3.1.1.3 C–D voltage.
SAE J823b, Apr 1968, 7	SAE J823b, Apr 1968, 7	S14.9.3.1.1.4 Voltage adjustments—fixed load flashers.
SAE J823b, Apr 1968, 8	SAE J823b, Apr 1968, 8	S14.9.3.1.1.5 Voltage adjustments—variable load flashers.
SAE J823b, Apr 1968, 8	SAE J823b, Apr 1968, 8	S14.9.3.1.1.6 Measurements.
SAE J823b, Apr 1968, 10	SAE J590b, Oct 1965, 10	S14.9.3.2.1 Starting time, voltage drop, and flash rate & percent current “on” time tests.
SAE J823b, Apr 1968, 10	SAE J590b, Oct 1965, 10	S14.9.3.2.1(a) Transients.
SAE J823b, Apr 1968, 10	SAE J823b, Apr 1968, 10 and 11	S14.9.3.2 Power supply specifications.
SAE J823b, Apr 1968, 10(a)	SAE J823b, Apr 1968, 10(a)	S14.9.3.2.1(b) Output voltage.
SAE J823b, Apr 1968, 10(b)	SAE J823b, Apr 1968, 10(b)	S14.9.3.2.1(c) Output current.
SAE J823b, Apr 1968, 10(c)	SAE J823b, Apr 1968, 10(c)	S14.9.3.2.1(d) Static regulation.
SAE J823b, Apr 1968, 10(c)	SAE J823b, Apr 1968, 10(c)	S14.9.3.2.1(e) Dynamic regulation.
SAE J823b, Apr 1968, 10(d)	SAE J823b, Apr 1968, 10(d)	S14.9.3.2.1(f) Ripple voltage.
SAE J823b, Apr 1968, 11	SAE J590b, Oct 1965, 11	S14.9.3.2.2 Durability tests.
SAE J823b, Apr 1968, 11	SAE J590b, Oct 1965, 11	S14.9.3.2.2(a) Transients.
SAE J823b, Apr 1968, 11	SAE J823b, Apr 1968, 10 and 11	S14.9.3.2 Power supply specifications.
SAE J823b, Apr 1968, 11(a)	SAE J590b, Oct 1965, 11(a)	S14.9.3.2.2(b) Output voltage.
SAE J823b, Apr 1968, 11(b)	SAE J590b, Oct 1965, 11(b)	S14.9.3.2.2(c) Output current.
SAE J823b, Apr 1968, 11(c)	SAE J590b, Oct 1965, 11(c)	S14.9.3.2.2(d) Static regulation.
SAE J823b, Apr 1968, 11(c)	SAE J590b, Oct 1965, 11(c)	S14.9.3.2.2(e) Dynamic regulation.
SAE J823b, Apr 1968, 11(d)	SAE J590b, Oct 1965, 11(d)	S14.9.3.2.2(f) Ripple voltage.
SAE J823b, Apr 1968, Figure 1	SAE J823b, Apr 1968, Figure 1	Figure 22.
SAE J887, Jul 1964	S4 Definitions—School bus signal lamps	S4 Definitions—School bus signal lamps.
SAE J887, Jul 1964	S6.4.1 Effective projected luminous lens area requirements.	S6.4.1 Effective projected luminous lens area requirements.
SAE J887, Jul 1964	S6.4.2 Visibility	S6.4.2 Visibility.
SAE J887, Jul 1964	S6.4.6 School bus signal lamp aiming	S6.4.5 School bus signal lamp aiming.
SAE J887, Jul 1964	S6.8.5.1 Photometry ex headlamp, license lamp, & DRL.	S14.2.1.2 School bus signal lamp aiming.
SAE J887, Jul 1964	S7.13.2 Physical test requirements	S7.11.14 Physical tests.
SAE J887, Jul 1964	Table I Activation—School bus signal lamps ..	Table I—a Activation—School bus signal lamps.
SAE J887, Jul 1964	Table IV School bus signal lamp—Effective projected luminous lens area.	Table IV—c School bus signal lamp—Effective projected luminous lens area.
SAE J887, Jul 1964	Table V School bus signal lamp visibility	Table V—a School bus signal lamp visibility.
SAE J887, Jul 1964, Table 1	S7.13.1 Photometry	S7.11.13 Photometry.
SAE J887, Jul 1964, Table 1	Table XVII School bus signal lamp photometry	Table XVII School bus signal lamp photometry.
SAE J910, Jan 1966	Table XXI	S9.6.3 Physical tests.
SAE J910, Jan 1966	Table XXI Vehicular hazard warning signal operating unit durability test.	S14.9.2 Vehicular hazard warning signal operating unit durability test.
SAE J910, Jan 1966, 1	S4 Definitions—Vehicular hazard warning signal operating unit.	S4 Definitions—Vehicular hazard warning signal operating unit.
SAE J910, Jan 1966, 3(b)	S7.14.6 Vehicular hazard warning signal operating unit.	S9.6.1 Combinations.
SAE J910, Jan 1966, 3(c)	S7.14.6.1 Operating unit switch	S9.6.2 Operation.
SAE J910, Jan 1966, 3(d)	S7.14.6 Vehicular hazard warning signal operating unit.	S9.6.1 Combinations.
SAE J910, Jan 1966, 3(e)	S7.14.6.1 Operating unit switch	S9.6.2 Operation.

APPENDIX A.—FMVSS NO. 108 REWRITE CROSS REFERENCE—Continued

Current FMVSS No. 108 or incorporated document citation	FMVSS No. 108 rewrite NPRM citation	FMVSS No. 108 rewrite final rule citation
SAE J910, Jan 1966, 4	Table XXI Vehicular hazard warning signal operating unit durability test—performance requirements.	S14.9.2.2 Performance requirements.
SAE J910, Jan 1966, 4	Table XXI Vehicular hazard warning signal operating unit durability test—procedure.	S14.9.2.1 Procedure.
SAE J910, Jan 1966, 4	Table XXI Vehicular hazard warning signal operating unit durability test—procedure.	S14.9.2.1.1 Circuit.
SAE J910, Jan 1966, 4	Table XXI Vehicular hazard warning signal operating unit durability test—procedure.	S14.9.2.1.2 Cycle.
SAE J910, Jan 1966, 4	Table XXI Vehicular hazard warning signal operating unit durability test—procedure.	S14.9.2.1.3 Voltage drop.
SAE J910, Jan 1966, 5	S7.14.8 Vehicular hazard warning signal pilot indicator.	S9.8.2 Single TS indicators.
SAE J910, Jan 1966, 5	S7.14.8 Vehicular hazard warning signal pilot indicator.	S9.8.3 Function.
SAE J910, Jan 1966, 5	S7.14.8.1 Indicator size and color	S9.8.4 Indicator size and color.
SAE J945, Feb 1966	S4 Definitions—Vehicular hazard warning signal flasher.	S4 Definitions—Vehicular hazard warning signal flasher.
SAE J945, Feb 1966	S7.14.7 Vehicular hazard warning signal flasher.	S9.7.1 Indicator signals.
SAE J945, Feb 1966	S7.14.8 Vehicular hazard warning signal pilot indicator.	S9.8.2 Single TS indicators.
SAE J945, Feb 1966	S7.14.8 Vehicular hazard warning signal pilot indicator.	S9.8.3 Function.
SAE J945, Feb 1966	S7.14.8.1 Indicator size and color	S9.8.4 Indicator size and color.
SAE J945, Feb 1966	Table XXI	S9.7.2 Physical tests.
SAE J945, Feb 1966	Table XXI Turn signal flasher and vehicular hazard warning signal flasher tests.	S14.9.3 Turn signal flasher and vehicular hazard warning signal warning flasher tests.
SAE J945, Feb 1966	Table XXI Vehicular hazard warning signal flasher durability test.	S14.9.3.10 Vehicular hazard warning signal flasher durability test.
SAE J945, Feb 1966	Table XXI Vehicular hazard warning signal flasher flash rate and percent current “on” time test.	S14.9.3.9 Vehicular hazard warning signal flasher flash rate and percent current “on” time test.
SAE J945, Feb 1966	Table XXI Vehicular hazard warning signal flasher flash rate and percent current “on” time test—procedure.	S14.9.3.9.1 Samples.
SAE J945, Feb 1966	Table XXI Vehicular hazard warning signal flasher starting time test.	S14.9.3.7 Vehicular hazard warning signal flasher starting time test.
SAE J945, Feb 1966	Table XXI Vehicular hazard warning signal flasher starting time test—procedure.	S14.9.3.7.1 Samples.
SAE J945, Feb 1966	Table XXI Vehicular hazard warning signal flasher voltage drop test.	S14.9.3.8 Vehicular hazard warning signal flasher voltage drop test.
SAE J945, Feb 1966	Table XXI Vehicular hazard warning signal flasher voltage drop test—performance requirements.	S14.9.3.8.3 Performance requirements.
SAE J945, Feb 1966	Table XXI Vehicular hazard warning signal flasher voltage drop test—procedure.	S14.9.3.8.1 Samples.
SAE J945, Feb 1966, 1	Table XXI Vehicular hazard warning signal flasher starting time test—performance requirements.	S14.9.3.7.3 Performance requirements.
SAE J945, Feb 1966, 1	Table XXI Vehicular hazard warning signal flasher starting time test—performance requirements.	S14.9.3.7.3(a) Normally closed contacts.
SAE J945, Feb 1966, 1	Table XXI Vehicular hazard warning signal flasher starting time test—performance requirements.	S14.9.3.7.3(b) Normally open contacts.
SAE J945, Feb 1966, 1	Table XXI Vehicular hazard warning signal flasher starting time test—procedure.	S14.9.3.7.2 Procedure.
SAE J945, Feb 1966, 1	Table XXI Vehicular hazard warning signal flasher starting time test—procedure.	S14.9.3.7.2.1 Setup.
SAE J945, Feb 1966, 1	Table XXI Vehicular hazard warning signal flasher starting time test—procedure.	S14.9.3.7.2.2 Measurement.
SAE J945, Feb 1966, 2	Table XXI Vehicular hazard warning signal flasher voltage drop test—procedure.	S14.9.3.8.2 Procedure.
SAE J945, Feb 1966, 2	Table XXI Vehicular hazard warning signal flasher voltage drop test—procedure.	S14.9.3.8.2.1 Setup.
SAE J945, Feb 1966, 2	Table XXI Vehicular hazard warning signal flasher voltage drop test—procedure.	S14.9.3.8.2.2 Measurement.
SAE J945, Feb 1966, 3	Table XXI Vehicular hazard warning signal flasher flash rate and percent current “on” time test—performance requirements.	S14.9.3.9.3 Performance requirements.

APPENDIX A.—FMVSS NO. 108 REWRITE CROSS REFERENCE—Continued

Current FMVSS No. 108 or incorporated document citation	FMVSS No. 108 rewrite NPRM citation	FMVSS No. 108 rewrite final rule citation
SAE J945, Feb 1966, 3	Table XXI Vehicular hazard warning signal flasher flash rate and percent current "on" time test—performance requirements.	S14.9.3.9.3(a) Normally closed contacts.
SAE J945, Feb 1966, 3	Table XXI Vehicular hazard warning signal flasher flash rate and percent current "on" time test—performance requirements.	S14.9.3.9.3(b) Normally open contacts.
SAE J945, Feb 1966, 3	Table XXI Vehicular hazard warning signal flasher flash rate and percent current "on" time test—procedure.	S14.9.3.9.2 Procedure.
SAE J945, Feb 1966, 3	Table XXI Vehicular hazard warning signal flasher flash rate and percent current "on" time test—procedure.	S14.9.3.9.2.1 Setup.
SAE J945, Feb 1966, 3	Table XXI Vehicular hazard warning signal flasher flash rate and percent current "on" time test—procedure.	S14.9.3.9.2.2 Temperature and voltage.
SAE J945, Feb 1966, 3	Table XXI Vehicular hazard warning signal flasher flash rate and percent current "on" time test—procedure.	S14.9.3.9.2.3 Measurement.
SAE J945, Feb 1966, 4	Table XXI Vehicular hazard warning signal flasher durability test—performance requirements.	S14.9.3.10.3 Performance requirements.
SAE J945, Feb 1966, 4	Table XXI Vehicular hazard warning signal flasher durability test—procedure.	S14.9.3.10.1 Samples.
SAE J945, Feb 1966, 4	Table XXI Vehicular hazard warning signal flasher durability test—procedure.	S14.9.3.10.2 Procedure.
SAE J945, Feb 1966, 4	Table XXI Vehicular hazard warning signal flasher durability test—procedure.	S14.9.3.10.2.1 Setup.
SAE J945, Feb 1966, 4	Table XXI Vehicular hazard warning signal flasher durability test—procedure.	S14.9.3.10.2.2 Temperature and voltage.
SAE J945, Feb 1966, 4	Table XXI Vehicular hazard warning signal flasher durability test—procedure.	S14.9.3.10.2.3 Duration.
SAE J945, Feb 1966, Figure 1	Figure 2	Figure 2.
SAE J1383, Apr 1985, 2.1	S4 Definitions—Headlamp	S4 Definitions—Headlamp.
SAE J1383, Apr 1985, 2.1.1	S17.3 Sealed beam headlamp markings	S6.5.3.3 Sealed beam headlamp markings.
SAE J1383, Apr 1985, 2.1.1	S4 Definitions—Sealed beam headlamp	S4 Definitions—Sealed beam headlamp.
SAE J1383, Apr 1985, 2.2	S4 Definitions—Upper beam	S4 Definitions—Upper beam.
SAE J1383, Apr 1985, 2.3	S4 Definitions—Lower beam	S4 Definitions—Lower beam.
SAE J1383, Apr 1985, 2.4	S4 Definitions—Mechanically aimable headlamp [OUT OF ALPHABETICAL ORDER].	S4 Definitions—Mechanically aimable headlamp.
SAE J1383, Apr 1985, 2.5	S4 Definitions—Aiming plane	S4 Definitions—Aiming plane.
SAE J1383, Apr 1985, 2.6	S4 Definitions—Headlamp mechanical axis	S4 Definitions—Headlamp mechanical axis.
SAE J1383, Apr 1985, 2.7	S4 Definitions—H-V axis	S4 Definitions—H-V axis.
SAE J1383, Apr 1985, 2.9	S4 Definitions—Seasoning	S4 Definitions—Seasoning.
SAE J1383, Apr 1985, 2.10	S4 Definitions—Design Voltage	S4 Definitions—Design Voltage.
SAE J1383, Apr 1985, 2.11	S4 Definitions—Test voltage	S4 Definitions—Test voltage.
SAE J1383, Apr 1985, 2.12	S4 Definitions—Rated voltage	S4 Definitions—Rated voltage.
SAE J1383, Apr 1985, 4.1.4.1	S6.8.5.6.1 Seasoning and test voltage	S14.2.5.4 Seasoning and test voltage.
SAE J1383, Apr 1985, 4.1.4.2	S6.8.5.6 Headlamp photometry measurements.	S14.2.5.3 Measurement distance.
SAE J1383, Apr 1985, 4.1.4.3	S6.8.5.6.1 Seasoning and test voltage	S14.2.5.4 Seasoning and test voltage.
SAE J1383, Apr 1985, 4.1.4.3	S6.8.5.6.2(a) Aiming—mechanical	S14.2.5.5.1 Mechanically aimable headlamps using an external aimer.
SAE J1383, Apr 1985, 4.5.1	S6.8.2 Samples for test	S14.1.4.1 Representative samples.
SAE J1383, Apr 1985, 4.7	Table XXIII Headlamp wattage test	S14.6.16 Headlamp wattage test.
SAE J1383, Apr 1985, 4.7	Table XXIII Headlamp wattage test—procedure.	S14.6.16.1 Procedure.
SAE J1383, Apr 1985, 5.3	Relocated to Part 564, Appendix C	Relocated to Part 564, Appendix C.
SAE J1383, Apr 1985, 5.3.3	S17.3 Sealed beam headlamp markings	S6.5.3.3 Sealed beam headlamp markings.
SAE J1383, Apr 1985, 5.4.3	S17.3 Sealed beam headlamp markings	S6.5.3.3 Sealed beam headlamp markings.
SAE J1383, Apr 1985, 5.4.4	S17.3 Sealed beam headlamp markings	S6.5.3.3 Sealed beam headlamp markings.
SAE J1383, Apr 1985, 5.4.4.1	S17.3 Sealed beam headlamp markings	S6.5.3.3 Sealed beam headlamp markings.
SAE J1383, Apr 1985, 5.4.4.2	S17.3 Sealed beam headlamp markings	S6.5.3.3 Sealed beam headlamp markings.
SAE J1383, Apr 1985, 5.4.4.3	S17.3 Sealed beam headlamp markings	S6.5.3.3 Sealed beam headlamp markings.
SAE J1383, Apr 1985, 5.4.5	S17.3 Sealed beam headlamp markings	S6.5.3.3 Sealed beam headlamp markings.
SAE J1383, Apr 1985, Figure 5	Relocated to Part 564, Appendix C	Relocated to Part 564, Appendix C.
SAE J1383, Apr 1985, Figure 6	Relocated to Part 564, Appendix C	Relocated to Part 564, Appendix C.
SAE J1383, Apr 1985, Figure 7	Relocated to Part 564, Appendix C	Relocated to Part 564, Appendix C.
SAE J1383, Apr 1985, Figure 8	Relocated to Part 564, Appendix C	Relocated to Part 564, Appendix C.
SAE J1383, Apr 1985, Figure 9	Relocated to Part 564, Appendix C	Relocated to Part 564, Appendix C.
SAE J1383, Apr 1985, Figure 10	Relocated to Part 564, Appendix C	Relocated to Part 564, Appendix C.

APPENDIX A.—FMVSS NO. 108 REWRITE CROSS REFERENCE—Continued

Current FMVSS No. 108 or incorporated document citation	FMVSS No. 108 rewrite NPRM citation	FMVSS No. 108 rewrite final rule citation
SAE J1383, Apr 1985, Figure 11	Relocated to Part 564, Appendix C	Relocated to Part 564, Appendix C.
SAE J1383, Apr 1985, Figure 11	Relocated to Part 564, Appendix C	Relocated to Part 564, Appendix C.
SAE J1383, Apr 1985, Figure 12	Relocated to Part 564, Appendix C	Relocated to Part 564, Appendix C.
SAE J1383, Apr 1985, Figure 13	Relocated to Part 564, Appendix C	Relocated to Part 564, Appendix C.
SAE J1383, Apr 1985, Figure 14	Relocated to Part 564, Appendix C	Relocated to Part 564, Appendix C.
SAE J1383, Apr 1985, Figure 15	Relocated to Part 564, Appendix C	Relocated to Part 564, Appendix C.
SAE J1395, Apr 1985, 2.1	S4 Definitions—Turn signal lamps	S4 Definitions—Turn signal lamps.
SAE J1395, Apr 1985, 4	S7.1.3 Physical tests	S7.1.1.14 Physical tests.
SAE J1395, Apr 1985, 4.1.5.2	S6.8.5.1.2 Multiple compartment & multiple lamp photometry.	S14.2.1.5.1 All photometered together.
SAE J1395, Apr 1985, 4.1.5.2	S6.8.5.1.2.2 Photometry of individual compartments/lamps.	S14.2.1.5.2(b) Measuring individually.
SAE J1395, Apr 1985, 4.1.5.2	S6.8.5.1.2.3 Multiple compartment/lamp photometry for wide vehicles.	S14.2.1.5.3 Multiple on 2032 mm or wider.
SAE J1395, Apr 1985, 5.1.5.2	S7.1.1.3.2 Ratio to parking lamps and clearance lamps.	S7.1.1.12 Ratio to parking lamps and clearance lamps.
SAE J1395, Apr 1985, 5.1.5.2	S7.1.1.3.2 Ratio to parking lamps and clearance lamps.	S7.1.1.12.1.
SAE J1395, Apr 1985, 5.1.5.2	S7.1.1.3.2 Ratio to parking lamps and clearance lamps.	S7.1.1.12.2.
SAE J1395, Apr 1985, 5.1.5.2	S7.1.1.3.2 Ratio to parking lamps and clearance lamps.	S7.1.1.12.3.
SAE J1395, Apr 1985, 5.1.5.2	S7.1.1.3.2 Ratio to parking lamps and clearance lamps.	S7.1.1.12.4.
SAE J1395, Apr 1985, 5.1.5.2	Table VI footnote 4	Table VI footnote 4.
SAE J1395, Apr 1985, 5.1.5.2	Table VI Front turn signal lamp—Photometric ratio.	Table VI Front turn signal lamp—Photometric ratio.
SAE J1395, Apr 1985, 5.1.5.2	Table VII footnote 7	Table VII footnote 7.
SAE J1395, Apr 1985, 5.1.5.2	Table VII footnote 8	Table VII footnote 8.
SAE J1395, Apr 1985, 5.1.5.2	Table VII Rear turn signal lamp—Photometric ratio.	Table VII Rear turn signal lamp—Photometric ratio.
SAE J1395, Apr 1985, 5.1.5.3	Table VII footnote 6	Table VII footnote 6.
SAE J1395, Apr 1985, 5.1.5.4	Table VI Front turn signal lamp—1.5 × base individual point photometry.	Table VI—b Front turn signal lamp—1.5 × base individual point photometry.
SAE J1395, Apr 1985, 5.1.5.4	Table VI Front turn signal lamp—1.5 × base zone photometry.	Table VI—b Front turn signal lamp—1.5 × base group photometry.
SAE J1395, Apr 1985, 5.1.5.4	Table VI Front turn signal lamp—2 × base individual point photometry.	Table VI—b Front turn signal lamp—2 × base individual point photometry.
SAE J1395, Apr 1985, 5.1.5.4	Table VI Front turn signal lamp—2 × base zone photometry.	Table VI—b Front turn signal lamp—2 × base group photometry.
SAE J1395, Apr 1985, 5.1.5.4	Table VI Front turn signal lamp—2.5 × base individual point photometry.	Table VI—a Front turn signal lamp—2.5 × base individual point photometry.
SAE J1395, Apr 1985, 5.1.5.4	Table VI Front turn signal lamp—2.5 × base zone photometry.	Table VI—a Front turn signal lamp—2.5 × base group photometry.
SAE J1395, Apr 1985, 5.1.5.5	S7.1.1.2.1 Spacing measurement for non reflector lamps.	S7.1.1.10.2 Spacing measurement for non reflector lamps.
SAE J1395, Apr 1985, 5.1.5.6	S7.1.1.2.2 Spacing measurement for lamps with reflectors.	S7.1.1.10.3 Spacing measurement for lamps with reflectors.
SAE J1395, Apr 1985, 5.3.1	S7.1.3 Physical tests	S7.1.2.14 Physical tests.
SAE J1395, Apr 1985, 5.3.1	S7.1.4 Combined lamp bulb indexing	S7.1.3 Combined lamp bulb indexing.
SAE J1395, Apr 1985, 5.3.1	S7.1.4 Combined lamp bulb indexing	S7.1.3.1 Dual filament bulbs.
SAE J1395, Apr 1985, 5.3.1	S7.1.4 Combined lamp bulb indexing	S7.1.3.2 Socket indexing.
SAE J1395, Apr 1985, 5.3.2	Table IV Front turn signal lamp—Effective projected luminous lens area.	Table IV—a Front turn signal lamp—Effective projected luminous lens area.
SAE J1395, Apr 1985, 5.3.2	Table IV Rear turn signal lamp—Effective projected luminous lens area.	Table IV—a Rear turn signal lamp—Effective projected luminous lens area.
SAE J1395, Apr 1985, 5.4.1	Table V SAE turn signal lamp visibility	Table V—b SAE turn signal lamp visibility.
SAE J1395, Apr 1985, Table 1	S7.1.1.1 Photometry	S7.1.1.13 Photometry.
SAE J1395, Apr 1985, Table 1	S7.1.1.1 Photometry	S7.1.1.13.1.
SAE J1395, Apr 1985, Table 1	S7.1.1.1 Photometry	S7.1.1.13.2.
SAE J1395, Apr 1985, Table 1	S7.1.2.1 Photometry	S7.1.2.13 Photometry.
SAE J1395, Apr 1985, Table 1	S7.1.2.1 Photometry	S7.1.2.13.1.
SAE J1395, Apr 1985, Table 1	S7.1.2.3 Ratio to taillamps and clearance lamps.	S7.1.2.12 Ratio to taillamps and clearance lamps.
SAE J1395, Apr 1985, Table 1	S7.1.2.3 Ratio to taillamps and clearance lamps.	S7.1.2.12.1.
SAE J1395, Apr 1985, Table 1	S7.1.2.3 Ratio to taillamps and clearance lamps.	S7.1.2.12.4.
SAE J1395, Apr 1985, Table 1	Table VI Front turn signal lamp—Base zone photometry.	Table VI—a Front turn signal lamp—Base group photometry.

APPENDIX A.—FMVSS NO. 108 REWRITE CROSS REFERENCE—Continued

Current FMVSS No. 108 or incorporated document citation	FMVSS No. 108 rewrite NPRM citation	FMVSS No. 108 rewrite final rule citation
SAE J1395, Apr 1985, Table 1	Table VII Rear turn signal lamp—Amber lamp zone photometry.	Table VII Rear turn signal lamp—Amber lamp group photometry.
SAE J1395, Apr 1985, Table 1	Table VII Rear turn signal lamp—Red lamp zone photometry.	Table VII Rear turn signal lamp—Red lamp group photometry.
SAE J1395, Apr 1985, Table 1	Table VII footnote 5	Table VII footnote 5.
SAE J1395, Apr 1985, Table 2	Table VI Front turn signal lamp—1.5 × base individual point photometry.	Table VI—b Front turn signal lamp—1.5 × base individual point photometry.
SAE J1395, Apr 1985, Table 2	Table VI Front turn signal lamp—1.5 × base zone photometry.	Table VI—b Front turn signal lamp—1.5 × base group photometry.
SAE J1395, Apr 1985, Table 2	Table VI Front turn signal lamp—2 × base individual point photometry.	Table VI—b Front turn signal lamp—2 × base individual point photometry.
SAE J1395, Apr 1985, Table 2	Table VI Front turn signal lamp—2 × base zone photometry.	Table VI—b Front turn signal lamp—2 × base group photometry.
SAE J1395, Apr 1985, Table 2	Table VI Front turn signal lamp—2.5 × base individual point photometry.	Table VI—a Front turn signal lamp—2.5 × base individual point photometry.
SAE J1395, Apr 1985, Table 2	Table VI Front turn signal lamp—2.5 × base zone photometry.	Table VI—a Front turn signal lamp—2.5 × base group photometry.
SAE J1395, Apr 1985, Table 3	Table VI Front turn signal lamp—Base individual point photometry.	Table VI—a Front turn signal lamp—Base individual point photometry.
SAE J1395, Apr 1985, Table 3	Table VII Rear turn signal lamp—Amber lamp individual point photometry.	Table VII Rear turn signal lamp—Amber lamp individual point photometry.
SAE J1395, Apr 1985, Table 3	Table VII Rear turn signal lamp—Red lamp individual point photometry.	Table VII Rear turn signal lamp—Red lamp individual point photometry.
SAE J1395, Apr 1985, footnote a	Table VI footnote 1	Table VI footnote 1.
SAE J1395, Apr 1985, footnote a	Table VII footnote 1	Table VII footnote 1.
SAE J1395, Apr 1985, footnote b	Table VII footnote 4	Table VII footnote 4.
SAE J1398, May 1985, 2.1	S4 Definitions—Stop lamps	S4 Definitions—Stop lamps.
SAE J1398, May 1985, 4.1.5.2	S6.8.5.1.2 Multiple compartment & multiple lamp photometry.	S14.2.1.5.1 All photometered together.
SAE J1398, May 1985, 4.1.5.2	S6.8.5.1.2.2 Photometry of individual compartments/lamps.	S14.2.1.5.2(b) Measuring individually.
SAE J1398, May 1985, 4.1.5.2	S6.8.5.1.2.3 Multiple compartment/lamp photometry for wide vehicles.	S14.2.1.5.3 Multiple on 2032 mm or wider.
SAE J1398, May 1985, 5	S7.3.2 Physical tests	S7.3.14 Physical tests.
SAE J1398, May 1985, 5.1.5.2	S7.3.1.2 Ratio to taillamps	S7.3.12 Ratio to taillamps.
SAE J1398, May 1985, 5.1.5.2	S7.3.1.2 Ratio to taillamps	S7.3.12.1.
SAE J1398, May 1985, 5.1.5.2	S7.3.1.2 Ratio to taillamps	S7.3.12.2.
SAE J1398, May 1985, 5.1.5.2	S7.3.1.2 Ratio to taillamps	S7.3.12.3.
SAE J1398, May 1985, 5.1.5.2	S7.3.1.2 Ratio to taillamps	S7.3.12.4.
SAE J1398, May 1985, 5.1.5.2	Table IX footnote 6	Table IX footnote 6.
SAE J1398, May 1985, 5.1.5.2	Table IX footnote 7	Table IX footnote 5.
SAE J1398, May 1985, 5.1.5.2	Table IX Stop lamp—Photometric ratio	Table IX Stop lamp—Photometric ratio.
SAE J1398, May 1985, 5.3.1	S7.3.3 Combined lamp bulb indexing	S7.3.15 Combined lamp bulb indexing.
SAE J1398, May 1985, 5.3.1	S7.3.3 Combined lamp bulb indexing	S7.3.15.1 Dual filament bulbs.
SAE J1398, May 1985, 5.3.1	S7.3.3 Combined lamp bulb indexing	S7.3.15.2 Socket indexing.
SAE J1398, May 1985, 5.3.2	Table IV Stop lamp—Effective projected luminous lens area.	Table IV—a Stop lamp—Effective projected luminous lens area.
SAE J1398, May 1985, 5.4.1	Table V SAE stop lamp visibility	Table V—b SAE stop lamp visibility.
SAE J1398, May 1985, Table 1	S7.3.1 Photometry	S7.3.13 Photometry.
SAE J1398, May 1985, Table 1	S7.3.1 Photometry	S7.3.13 Photometry.
SAE J1398, May 1985, Table 1	S7.3.1 Photometry	S7.3.13.1.
SAE J1398, May 1985, Table 1	S7.3.1 Photometry	S7.3.13.1.
SAE J1398, May 1985, Table 1	Table IX Stop lamp—Individual point photometry.	Table IX Stop lamp—Individual point photometry.
SAE J1398, May 1985, Table 1	Table IX Stop lamp—Zone photometry	Table IX Stop lamp—Group photometry.
SAE J1398, May 1985, footnote a	Table IX footnote 1	Table IX footnote 1.
SAE J1398, May 1985, footnote a	Table IX footnote 1	Table IX footnote 1.
SAE J1398, May 1985, footnote b	Table IX footnote 3	Table IX footnote 3.
SAE J1398, May 1985, footnote b	Table IX footnote 3	Table IX footnote 3.
64 FR 16358	64 FR 16358	Table I—a Mounting height—Clearance lamps—rear.
64 FR 16358	64 FR 16358	Table I—a Mounting height—Identification lamps—rear.
64 FR 16358	64 FR 16358	Table I—b Mounting height—Clearance lamps—rear.
64 FR 16358	64 FR 16358	Table I—b Mounting height—Identification lamps—rear.
70 FR 65972	S6.7 Replacement equipment	S6.7 Replacement equipment.
Interpretation—Alkire 11/28/89	S6.2.2 Lamp or reflective device obstructed ...	S6.2.2 Lamp or reflective device obstructed.
Interpretation—Camp 6/17/97	S4 Definitions—Overall width	S4 Definitions—Overall width.
Interpretation—Clarke 7/28/05	S6.2.5 Auxiliary identification lamps	S6.1.3.6 Auxiliary lamp.

APPENDIX A.—FMVSS NO. 108 REWRITE CROSS REFERENCE—Continued

Current FMVSS No. 108 or incorporated document citation	FMVSS No. 108 rewrite NPRM citation	FMVSS No. 108 rewrite final rule citation
Interpretation—Faber 5/26/00	Table I Activation—Stop lamps	Table I-a Activation—Stop lamps.
Interpretation—Faber 5/26/00	Table I Activation—Stop lamps	Table I-b Activation—Stop lamps.
Interpretation—Faber 5/26/00	Table I Activation—Stop lamps	Table I-c Activation—Stop lamps.
Interpretation—King 7/12/00	S6.1.3 Mounting location and height	S6.1.3.1.
Interpretation—King 7/12/00	S6.1.3 Mounting location and height	S6.1.3.2.
Interpretation—Nakaya 6/18/85	S6.1.3.2.1 High mounted stop lamp mounting	S6.1.4.1.1 High mounted stop lamp mounting.
Interpretation—Parkyn 6/1/98	Table IX footnote 5	Table XIII-b footnote 3.
Interpretation—Spingler 4/6/2000	S14.10.1.5 Measuring the cutoff parameter	S10.18.9.1.5 Measuring the cutoff parameter.
Interpretation—Spingler 7/2/99	Table XIX 10° U–90°U Test area	Table XIX 10° U–90°U Test area.
Various	S17 Headlamp marking requirements	S6.5.3 Headlamp marking requirements.
New figure	Figure 12–1	Figure 12–1.
New figure	Figure 12–2	Figure 12–2.
New language	Table V footnote 1	Table V footnote 1.
New reference to other sections	S17.5 Additional headlamp markings	S6.5.3.5 Additional headlamp markings.
New section	New section	S7.1.1.1 Number [New section—points to Table I].
New section	New section	S7.1.1.2 Color of light [New section—points to Table I].
New section	New section	S7.1.1.3 Mounting location [New section—points to Table I].
New section	New section	S7.1.1.4 Mounting height [New section—points to Table I].
New section	New section	S7.1.1.5 Activation [New section—points to Table I].
New section	New section	S7.1.1.6 Effective projected luminous lens area [New section—points to Table IV–a].
New section	New section	S7.1.1.7 Visibility [New section—points to S6.4].
New section	New section	S7.1.1.8 Indicator [New section—points to S9.3].
New section	New section	S7.1.1.9 Markings [New section—points to S6.5].
New section	New section	S7.1.2.1 Number [New section—points to Table I].
New section	New section	S7.1.2.2 Color of light [New section—points to Table I].
New section	New section	S7.1.2.3 Mounting location [New section—points to Table I and S6.1.3.2].
New section	New section	S7.1.2.4 Mounting height [New section—points to Table I].
New section	New section	S7.1.2.5 Activation [New section—points to Table I].
New section	New section	S7.1.2.6 Effective projected luminous lens area [New section—points to Table IV–a].
New section	New section	S7.1.2.7 Visibility [New section—points to S6.4].
New section	New section	S7.1.2.8 Indicator [New section—points to S9.3].
New section	New section	S7.1.2.9 Markings [New section—points to S6.5].
New section	New section	S7.1.2.10 Spacing to other lamps [New section—No requirement].
New section	New section	S7.2 Taillamps.
New section	New section	S7.2.1 Number [New section—points to Table I].
New section	New section	S7.2.2 Color of light [New section—points to Table I].
New section	New section	S7.2.3 Mounting location [New section—points to Table I and S6.1.3.2].
New section	New section	S7.2.4 Mounting height [New section—points to Table I].
New section	New section	S7.2.4 Mounting height [New section—points to Table I].
New section	New section	S7.2.5 Activation [New section—points to Table I].
New section	New section	S7.2.6 Effective projected luminous lens area [New section—No requirement].
New section	New section	S7.2.7 Visibility [New section—points to S6.4].
New section	New section	S7.2.8 Indicator [New section—No requirement].

APPENDIX A.—FMVSS NO. 108 REWRITE CROSS REFERENCE—Continued

Current FMVSS No. 108 or incorporated document citation	FMVSS No. 108 rewrite NPRM citation	FMVSS No. 108 rewrite final rule citation
New section	New section	S7.2.9 Markings [New section—points to S6.5].
New section	New section	S7.2.10 Spacing to other lamps [New section—No requirement].
New section	New section	S7.2.12 Ratio [New section—points to S7.1.2.12 and 7.3.12].
New section	New section	S7.3 Stop lamps.
New section	New section	S7.3.1 Number [New section—points to Table I].
New section	New section	S7.3.2 Color of light [New section—points to Table I].
New section	New section	S7.3.3 Mounting location [New section—points to Table I and S6.1.3.2].
New section	New section	S7.3.4 Mounting height [New section—points to Table I].
New section	New section	S7.3.5 Activation [New section—points to Table I].
New section	New section	S7.3.6 Effective projected luminous lens area [New section—points to Table IV—a].
New section	New section	S7.3.7 Visibility [New section—points to S6.4].
New section	New section	S7.3.8 Indicator [New section—No requirement].
New section	New section	S7.3.9 Markings [New section—points to S6.5].
New section	New section	S7.3.10 Spacing to other lamps [New section—No requirement].
New section	New section	S7.4 Side marker lamps.
New section	New section	S7.4.1 Number [New section—points to Table I].
New section	New section	S7.4.2 Color of light [New section—points to Table I].
New section	New section	S7.4.3 Mounting location [New section—points to Table I].
New section	New section	S7.4.5 Activation [New section—points to Table I].
New section	New section	S7.4.6 Effective projected luminous lens area [New section—No requirement].
New section	New section	S7.4.7 Visibility [New section—No requirement].
New section	New section	S7.4.8 Indicator [New section—No requirement].
New section	New section	S7.4.9 Markings [New section—points to S6.5].
New section	New section	S7.4.10 Spacing to other lamps [New section—No requirement].
New section	New section	S7.4.11 Multiple compartments and multiple lamps [New section—No requirement].
New section	New section	S7.4.12 Ratio [New section—No requirement].
New section	New section	S7.5 Clearance and identification lamps.
New section	New section	S7.5.1 Number [New section—points to Table I].
New section	New section	S7.5.2 Color of light [New section—points to Table I].
New section	New section	S7.5.3 Mounting location [New section—points to Table I].
New section	New section	S7.5.4 Mounting height [New section—points to Table I].
New section	New section	S7.5.5 Activation [New section—points to Table I].
New section	New section	S7.5.6 Effective projected luminous lens area [New section—No requirement].
New section	New section	S7.5.7 Visibility [New section—No requirement].
New section	New section	S7.5.8 Indicator [New section—No requirement].
New section	New section	S7.5.9 Markings [New section—points to S6.5].
New section	New section	S7.5.10 Spacing to other lamps [New section—No requirement].
New section	New section	S7.5.11 Multiple compartments and multiple lamps [New section—No requirement].

APPENDIX A.—FMVSS NO. 108 REWRITE CROSS REFERENCE—Continued

Current FMVSS No. 108 or incorporated document citation	FMVSS No. 108 rewrite NPRM citation	FMVSS No. 108 rewrite final rule citation
New section	New section	S7.5.12 Ratio.
New section	New section	S7.5.12.1 Clearance lamps [New section—points to S7.1.1.12 and S7.1.2.12].
New section	New section	S7.5.12.2 Identification lamps [New section—No requirement].
New section	New section	S7.6 Backup lamps.
New section	New section	S7.6.1 Number [New section—points to Table I].
New section	New section	S7.6.2 Color of light.
New section	New section	S7.6.2.1 [New section—points to Table I].
New section	New section	S7.6.3 Mounting location [New section—points to Table I].
New section	New section	S7.6.4 Mounting height [New section—No requirement].
New section	New section	S7.6.5 Activation [New section—points to Table I].
New section	New section	S7.6.6 Effective projected luminous lens area [New section—No requirement].
New section	New section	S7.6.7 Visibility [New section—see Table V-a].
New section	New section	S7.6.8 Indicator [New section—No requirement].
New section	New section	S7.6.9 Markings [New section—points to S6.5].
New section	New section	S7.6.10 Spacing to other lamps [New section—No requirement].
New section	New section	S7.6.11 Multiple compartments and multiple lamps [New section—No requirement].
New section	New section	S7.6.12 Ratio [New section—No requirement].
New section	New section	S7.7 License plate lamps.
New section	New section	S7.7.1 Number [New section—points to Table I and S6.1.1].
New section	New section	S7.7.2 Color of light [New section—points to Table I].
New section	New section	S7.7.3 Mounting location [New section—points to Table I].
New section	New section	S7.7.4 Mounting height [New section—No requirement].
New section	New section	S7.7.5 Activation [New section—points to Table I].
New section	New section	S7.7.6 Effective projected luminous lens area [New section—No requirement].
New section	New section	S7.7.7 Visibility [New section—No requirement].
New section	New section	S7.7.8 Indicator [New section—No requirement].
New section	New section	S7.7.9 Markings [New section—points to S6.5].
New section	New section	S7.7.10 Spacing to other lamps [New section—No requirement].
New section	New section	S7.7.11 Multiple compartments and multiple lamps [New section—No requirement].
New section	New section	S7.7.12 Ratio [New section—No requirement].
New section	New section	S7.7.15 Installation.
New section	New section	S7.8 Parking lamps.
New section	New section	S7.8.1 Number [New section—points to Table I].
New section	New section	S7.8.2 Color of light [New section—points to Table I].
New section	New section	S7.8.3 Mounting location [New section—points to Table I].
New section	New section	S7.8.4 Mounting height [New section—points to Table I].
New section	New section	S7.8.5 Activation [New section—points to Table I].
New section	New section	S7.8.6 Effective projected luminous lens area [New section—No requirement].
New section	New section	S7.8.7 Visibility [New section—points to S6.4].
New section	New section	S7.8.8 Indicator [New section—No requirement].

APPENDIX A.—FMVSS NO. 108 REWRITE CROSS REFERENCE—Continued

Current FMVSS No. 108 or incorporated document citation	FMVSS No. 108 rewrite NPRM citation	FMVSS No. 108 rewrite final rule citation
New section	New section	S7.8.9 Markings [New section—points to S6.5].
New section	New section	S7.8.10 Spacing to other lamps [New section—No requirement].
New section	New section	S7.8.11 Multiple compartments and multiple lamps [New section—No requirement].
New section	New section	S7.8.12 Ratio [New section—points to S7.1.1.12].
New section	New section	S7.9 High-mounted lamps.
New section	New section	S7.9.1 Number [New section—points to Table I and S6.1.1.2].
New section	New section	S7.9.2 Color of light [New section—points to Table I].
New section	New section	S7.9.3 Mounting location [New section—points to Table I].
New section	New section	S7.9.4 Mounting height [New section—points to Table I and S6.1.4.1].
New section	New section	S7.9.5 Activation [New section—points to Table I].
New section	New section	S7.9.6 Effective projected luminous lens area [New section—points to Table IV—b].
New section	New section	S7.9.7 Visibility [New section—points to Table V—a].
New section	New section	S7.9.8 Indicator [New section—No requirement].
New section	New section	S7.9.9 Markings [New section—points to S6.5].
New section	New section	S7.9.10 Spacing to other lamps [New section—No requirement].
New section	New section	S7.9.11 Multiple compartments and multiple lamps [New section—No requirement].
New section	New section	S7.9.12 Ratio [New section—No requirement].
New section	New section	S7.10 Daytime running lamps (DRLs).
New section	New section	S7.10.1 Number [New section—points to Table I].
New section	New section	S7.10.2 Color of light [New section—points to Table I].
New section	New section	S7.10.3 Mounting location [New section—points to Table I].
New section	New section	S7.10.4 Mounting height [New section—points to Table I and S7.10.13(b)].
New section	New section	S7.10.5 Activation [New section—points to Table I and S7.10.10.1(c)].
New section	New section	S7.10.6 Effective projected luminous lens area [New section—No requirement].
New section	New section	S7.10.7 Visibility [New section—No requirement].
New section	New section	S7.10.8 Indicator [New section—No requirement].
New section	New section	S7.10.9 Markings [New section—points to S6.5].
New section	New section	S7.10.11 Multiple compartments and multiple lamps [New section—No requirement].
New section	New section	S7.10.12 Ratio [New section—No requirement].
New section	New section	S7.11 School bus signal lamps.
New section	New section	S7.11.1 Number [New section—points to Table I].
New section	New section	S7.11.2 Color of light [New section—points to Table I].
New section	New section	S7.11.3 Mounting location [New section—points to Table I].
New section	New section	S7.11.4 Mounting height [New section—points to Table I].
New section	New section	S7.11.5 Activation [New section—points to Table I].
New section	New section	S7.11.6 Effective projected luminous lens area [New section—points to Table IV—c].
New section	New section	S7.11.7 Visibility [New section—points to Table V—a].

APPENDIX A.—FMVSS NO. 108 REWRITE CROSS REFERENCE—Continued

Current FMVSS No. 108 or incorporated document citation	FMVSS No. 108 rewrite NPRM citation	FMVSS No. 108 rewrite final rule citation
New section	New section	S7.11.8 Indicator [New section—No requirement].
New section	New section	S7.11.9 Markings [New section—points to S6.5].
New section	New section	S7.11.10 Spacing to other lamps [New section—No requirement].
New section	New section	S7.11.11 Multiple compartments and multiple lamps [New section—No requirement].
New section	New section	S7.11.12 Ratio [New section—No requirement].
New section	New section	S8.1.1 Number [New section—points to Table I].
New section	New section	S8.1.2 Color [New section—points to Table I].
New section	New section	S8.1.3 Mounting location [New section—points to Table I].
New section	New section	S8.1.4 Mounting height [New section—points to Table I].
New section	New section	S8.1.5 Activation [New section—No requirement].
New section	New section	S8.1.6 Effective projected luminous lens area [New section—No requirement].
New section	New section	S8.1.7 Visibility [New section—No requirement].
New section	New section	S8.1.8 Indicator [New section—No requirement].
New section	New section	S8.1.9 Markings [New section—points to S6.5].
New section	New section	S8.1.10 Spacing to other lamps [New section—No requirement].
New section	New section	S10.3 Number [New section—points to Table I].
New section	New section	S10.4 Color of light [New section—points to Table I].
New section	New section	S10.5 Mounting location [New section—points to Table I].
New section	New section	S10.6 Mounting height [New section—points to Table I].
New section	New section	S10.7 Activation [New section—points to Table I, Table II, and S6.1.5].
New section	New section	S10.8 Effective projected luminous lens area [New section—No requirement].
New section	New section	S10.9 Visibility [New section—No requirement].
New section	New section	S10.10 Indicator [New section—points to S9.5].
New section	New section	S10.11 Markings [New section—points to S6.5].
New section	New section	S10.12 Spacing to other lamps [New section—points to S6.1.3.5].
New table	New table	Table III Marking Requirements Locations [New Table—points to marking requirements].
New title	S6 Vehicle requirements	S6 Vehicle requirements.
New title	New title	S6.1.3 Mounting location.
New title	New title	S6.1.3.5 Headlamp beam mounting.
New title	S6.2 Impairment	S6.2 Impairment.
New title	S6.4 Visibility, and aiming	S6.4 Lens area, visibility, and aiming.
New title	S6.5 Marking	S6.5 Marking.
New title	S8.2 Simultaneous beam activation	S6.1.5.2 Simultaneous beam activation.
New title	New title	S6.6 Associated equipment.
New title	S7 Signal lamps, reflective devices, and associated equipment requirements.	S7 Signal lamp requirements.
New title	S7.1 Turn signal lamps	S7.1 Turn signal lamps.
New title	S7.1.1 Front turn signal lamps	S7.1.1 Front turn signal lamps.
New title	New title	S7.1.2 Rear turn signal lamps.
New title	S7.10 Reflex reflectors	S8.1 Reflex reflectors.
New title	Table III Application pattern	S8.2.1.4 Application pattern.
New title	New title	S9.1 Turn signal operating unit.
New title	New title	S9.2 Turn signal flasher.
New title	New title	S9.6 Vehicular hazard warning signal operating unit.

APPENDIX A.—FMVSS NO. 108 REWRITE CROSS REFERENCE—Continued

Current FMVSS No. 108 or incorporated document citation	FMVSS No. 108 rewrite NPRM citation	FMVSS No. 108 rewrite final rule citation
New title	New title	S9.7 Vehicular hazard warning signal flasher.
New title	New title	S9.8 Vehicular hazard warning signal pilot indicator.
New title	S7.14.8 Vehicular hazard warning signal pilot indicator.	S9.8.1 Two TS indicators.
New title	New title	S10.1 Vehicle headlighting systems.
New title	S9.4 Physical tests	S10.13.4 Physical tests.
New title	S10.7 Physical tests	S10.14.7 Physical tests.
New title	S11.5 Markings	S10.15.4 Markings.
New title	S12.3 Physical tests	S10.16.3 Physical tests.
New title	New title	S11.4 Physical tests.
New title	New title	S14 Physical and photometry test procedures and performance requirements.
New title	New title	S14.1 General test procedures and performance requirements.
New title	S6.8.5.1 Photometry ex headlamp, license lamp, & DRL.	S14.2.1 Photometry measurements for all lamps except license lamps, headlamps, and DRLs.
New title	S6.8.5.1.2 Multiple compartment & multiple lamp photometry.	S14.2.1.5 Multiple compartment and multiple lamp photometry of turn signal lamps, stop lamps, and taillamps.
New title	S6.8.5.5 Daytime running lamp (DRL) photometry measurements.	S14.2.4 Daytime running lamp (DRL) photometry measurements.
New title	S6.8.5.6 Headlamp photometry measurements.	S14.2.5 Headlamp photometry measurements.
New title	S6.8.5.6.2(c) Aiming—LB VOL/VOR vertical ...	S14.2.5.5.3 Visually aimable lower beam headlamps—vertical aim.
New title	S6.8.5.6.2(e) Aiming—UB VOL/VOR vertical ..	S14.2.5.5.5 Visually aimable upper beam headlamps—vertical aim.
New title	S6.8.5.6.2(f) Aiming—UB VOL/VOR horizontal	S14.2.5.5.6 Visually aimable upper beam headlamps—horizontal aim.
New title	S6.8.5.6.4 Photometer	S14.2.5.7 Photometer.
New title	S6.8.5.6.2(h) Aiming—Moveable reflector	S14.2.5.10 Moveable reflector aimed headlamp photometry measurements.
New title	New title	S14.4 General test procedures and performance requirements.
New title	New title	S14.4.1.2 General procedure.
New title	Table XXII Plastic optical material tests—application.	S14.4.2 Plastic optical materials tests.
New title	Table XXII	S14.5 Signal lamp and reflective device physical test procedures and performance requirements.
New title	Table XXIII	S14.6 Headlamp physical test procedures and performance requirements.
New title	Table XXIII Humidity test	S14.6.7 Humidity test.
New title	Table XXIII Humidity test—procedure	S14.6.7.1 Procedure.
New title	Table XXIII	S14.7 Replaceable light source physical test procedures and performance requirements.
New title	Table XXIII	S14.8 Vehicle headlamp aiming device (VHAD) physical test procedures and performance requirements.
New title	Table XXI	S14.9 Associated equipment physical test procedures and performance requirements.

APPENDIX B.—FMVSS NO. 108 REWRITE CROSS REFERENCE

Current FMVSS No. 108 or incorporated document citation	FMVSS No. 108 rewrite NPRM citation	FMVSS No. 108 rewrite final rule citation
S1 Scope	S1 Scope	S1; Table I; Table III.
S2 Purpose	S2 Purpose	S2 Purpose.
S3 Application	S3 Application	S3 Application (except section citation).
S4 Definitions	S4 Definitions	S4 Definitions.
S4 Definitions—Aiming plane	S4 Definitions—Aiming plane	SAE J1383, Apr 1985, 2.5.
S4 Definitions—Aiming reference plane	S4 Definitions—Aiming reference plane	S4 Definitions—Aiming reference plane.
S4 Definitions—Aiming screws	S4 Definitions—Aiming screws	SAE J580, Dec 1986, 2.4.
S4 Definitions—Axis of reference	S4 Definitions—Axis of reference	S4 Definitions—Axis of reference.
S4 Definitions—Backup lamp	S4 Definitions—Backup lamp	SAE J593c, Feb 1968.
S4 Definitions—Beam contributor	S4 Definitions—Beam contributor	S4 Definitions—Beam contributor.
S4 Definitions—Cargo lamp	S4 Definitions—Cargo lamp	S4 Definitions—Cargo lamp.

APPENDIX B.—FMVSS NO. 108 REWRITE CROSS REFERENCE—Continued

Current FMVSS No. 108 or incorporated document citation	FMVSS No. 108 rewrite NPRM citation	FMVSS No. 108 rewrite final rule citation
S4 Definitions—Clearance lamps	S4 Definitions—Clearance lamps	SAE J592e, Jul 1972, 2.1.
S4 Definitions—Coated materials	S4 Definitions—Coated materials	SAE J576, Jul 1991, 2.2.1.1.
S4 Definitions—Color	S4 Definitions—Color	SAE J578c, Feb 1977, 2.
S4 Definitions—Color bleeding	S4 Definitions—Color bleeding	SAE J576, Jul 1991, 2.2.3.1.
S4 Definitions—Combination clearance and side marker lamps.	S4 Definitions—Combination clearance and side marker lamps.	SAE J592e, Jul 1972, 2.3.
S4 Definitions—Cracking	S4 Definitions—Cracking	SAE J576, Jul 1991, 2.2.3.3.
S4 Definitions—Crazing	S4 Definitions—Crazing	SAE J576, Jul 1991, 2.2.3.2.
S4 Definitions—Cutoff	S4 Definitions—Cutoff	S4 Definitions—Cutoff.
S4 Definitions—Delamination	S4 Definitions—Delamination	SAE J576, Jul 1991, 2.2.3.5.
S4 Definitions—Design Voltage	S4 Definitions—Design Voltage	SAE J1383, Apr 1985, 2.10.
S4 Definitions—Direct reading indicator	S4 Definitions—Direct reading indicator	S4 Definitions—Direct reading indicator.
S4 Definitions—Effective light-emitting surface	S4 Definitions—Effective light-emitting surface	S4 Definitions—Effective light-emitting surface.
S4 Definitions—Effective projected luminous lens area.	S4 Definitions—Effective projected luminous lens area.	S4 Definitions—Effective projected luminous lens area.
S4 Definitions—Effective projected luminous lens area.	S4 Definitions—Effective projected luminous lens area.	S6.3.
S4 Definitions—Exposed	S4 Definitions—Exposed	SAE J576, Jul 1991, 2.2.2.1.
S4 Definitions—Filament	S4 Definitions—Filament	S4 Definitions—Filament.
S4 Definitions—Flash	S4 Definitions—Flash	S4 Definitions—Flash.
S4 Definitions—Fully opened	S4 Definitions—Fully opened	S4 Definitions—Fully opened.
S4 Definitions—Haze	S4 Definitions—Haze	SAE J576, Jul 1991, 2.2.3.4.
S4 Definitions—Headlamp	S4 Definitions—Headlamp	SAE J1383, Apr 1985, 2.1.
S4 Definitions—Headlamp concealment device	S4 Definitions—Headlamp concealment device.	S4 Definitions—Headlamp concealment device.
S4 Definitions—Headlamp mechanical axis	S4 Definitions—Headlamp mechanical axis	SAE J1383, Apr 1985, 2.6.
S4 Definitions—Headlamp test fixture	S4 Definitions—Headlamp test fixture	S4 Definitions—Headlamp test fixture.
S4 Definitions—High mounted stop lamp	S4 Definitions—High mounted stop lamp	SAE J186a, Sep 1977, 2.1.
S4 Definitions—H-V axis	S4 Definitions—H-V axis	SAE J1383, Apr 1985, 2.7.
S4 Definitions—Identification lamps	S4 Definitions—Identification lamps	SAE J592e, Jul 1972, 2.4.
S4 Definitions—Integral beam headlamp	S4 Definitions—Integral beam headlamp	S4 Definitions—Integral beam headlamp.
S4 Definitions—License plate lamps	S4 Definitions—License plate lamps	SAE J587, Oct 1981, 2.
S4 Definitions—Lower beam	S4 Definitions—Lower beam	SAE J1383, Apr 1985, 2.3.
S4 Definitions—Material	S4 Definitions—Material [OUT OF ALPHABETICAL ORDER].	SAE J576, Jul 1991, 2.2.1.
S4 Definitions—Mechanically aimable headlamp.	S4 Definitions—Mechanically aimable headlamp [OUT OF ALPHABETICAL ORDER].	SAE J1383, Apr 1985, 2.4.
S4 Definitions—Motor driven cycle	S4 Definitions—Motor driven cycle	SAE J584, Apr 1964.
S4 Definitions—Motorcycle or motor driven cycle headlamp.	S4 Definitions—Motorcycle or motor driven cycle headlamp.	SAE J584, Apr 1964.
S4 Definitions—Mounting ring	S4 Definitions—Mounting ring	SAE J580, Dec 1986, 2.2.
S4 Definitions—Mounting ring (type F sealed beam).	S4 Definitions—Mounting ring (type F sealed beam).	S7.3.7(e)(1).
S4 Definitions—Multiple compartment lamp	S4 Definitions—Multiple compartment lamp	S4 Definitions—Multiple compartment lamp.
S4 Definitions—Multiple lamp arrangement	S4 Definitions—Multiple lamp arrangement	S4 Definitions—Multiple lamp arrangement.
S4 Definitions—Optically combined	S4 Definitions—Optically combined	S5.1.1.11.
S4 Definitions—Optically combined	S4 Definitions—Optically combined	S5.4(b).
S4 Definitions—Optically combined	S4 Definitions—Optically combined	S5.4(c).
S4 Definitions—Optically combined	S4 Definitions—Optically combined	SAE J387, Nov 1987.
S4 Definitions—Overall width	S4 Definitions—Overall width	Interpretation—Camp 6/17/97.
S4 Definitions—Overall width	S4 Definitions—Overall width	Table IV, footnote 1.
S4 Definitions—Parking lamps	S4 Definitions—Parking lamps	SAE J222, Dec 1970, 2.
S4 Definitions—Protected	S4 Definitions—Protected	SAE J576, Jul 1991, 2.2.2.2.
S4 Definitions—Rated voltage	S4 Definitions—Rated voltage	SAE J1383, Apr 1985, 2.12.
S4 Definitions—Reflex reflectors	S4 Definitions—Reflex reflectors	SAE J594f, Jan 1977, 2.
S4 Definitions—Remote reading indicator	S4 Definitions—Remote reading indicator	S4 Definitions—Remote reading indicator.
S4 Definitions—Replaceable bulb headlamp	S4 Definitions—Replaceable bulb headlamp	S4 Definitions—Replaceable bulb headlamp.
S4 Definitions—Replaceable light source	S4 Definitions—Replaceable light source	S4 Definitions—Replaceable light source.
S4 Definitions—Retaining ring	S4 Definitions—Retaining ring	SAE J580, Dec 1986, 2.3.
S4 Definitions—Retaining ring (type F sealed beam).	S4 Definitions—Retaining ring (type F sealed beam).	S7.3.7(e)(2).
S4 Definitions—School bus signal lamps	S4 Definitions—School bus signal lamps	SAE J887, Jul 1964.
S4 Definitions—Sealed beam headlamp	S4 Definitions—Sealed beam headlamp	SAE J1383, Apr 1985, 2.1.1.
S4 Definitions—Sealed beam headlamp assembly.	S4 Definitions—Sealed beam headlamp assembly.	SAE J580, Dec 1986, 2.1.
S4 Definitions—Seasoning	S4 Definitions—Seasoning	SAE J1383, Apr 1985, 2.9.
S4 Definitions—Semiautomatic headlamp beam switching device.	S4 Definitions—Semiautomatic headlamp beam switching device.	SAE J565b, Feb 1969, 1.
S4 Definitions—Side marker lamps	S4 Definitions—Side marker lamps	SAE J592e, Jul 1972, 2.2.

APPENDIX B.—FMVSS NO. 108 REWRITE CROSS REFERENCE—Continued

Current FMVSS No. 108 or incorporated document citation	FMVSS No. 108 rewrite NPRM citation	FMVSS No. 108 rewrite final rule citation
S4 Definitions—Stop lamps	S4 Definitions—Stop lamps	SAE J1398, May 1985, 2.1.
S4 Definitions—Stop lamps	S4 Definitions—Stop lamps	SAE J586, Feb 1984, 2.1.
S4 Definitions—Taillamps	S4 Definitions—Taillamps	SAE J585e, Sep 1977, 2.1.
S4 Definitions—Test voltage	S4 Definitions—Test voltage	SAE J1383, Apr 1985, 2.11.
S4 Definitions—Turn signal flasher	S4 Definitions—Turn signal flasher	SAE J590b, Oct 1965.
S4 Definitions—Turn signal lamps	S4 Definitions—Turn signal lamps	SAE J1395, Apr 1985, 2.1.
S4 Definitions—Turn signal lamps	S4 Definitions—Turn signal lamps	SAE J588, Nov 1984, 2.1.
S4 Definitions—Turn signal operating unit	S4 Definitions—Turn signal operating unit	SAE J589, Apr 1964.
S4 Definitions—Upper beam	S4 Definitions—Upper beam	SAE J1383, Apr 1985, 2.2.
S4 Definitions—Vehicle headlamp aiming device or VHAD.	S4 Definitions—Vehicle headlamp aiming device or VHAD.	S4 Definitions—Vehicle headlamp aiming device or VHAD.
S4 Definitions—Vehicular hazard warning signal flasher.	S4 Definitions—Vehicular hazard warning signal flasher.	SAE J945, Feb 1966.
S4 Definitions—Vehicular hazard warning signal operating unit.	S4 Definitions—Vehicular hazard warning signal operating unit.	SAE J910, Jan 1966, 1.
S4 Definitions—Visually/optically aimable headlamp.	S4 Definitions—Visually/optically aimable headlamp.	S4 Definitions—Visually/optically aimable headlamp.
S5 References to SAE publications	S5 References to SAE publications	S6 Subreferenced SAE Standards and Recommended Practices.
S5.1 Recommended=mandatory	S5.1 Recommended=mandatory	S6.1.
S5.1 SAE Publications	S5.1 SAE Publications	S5.2.1.
S6 Vehicle requirements	S6 Vehicle requirements	New title.
S6.1 Required lamps, reflective devices, and associated equipment by vehicle type.	S6.1 Required lamps, reflective devices, and associated equipment by vehicle type.	Table I.
S6.1 Required lamps, reflective devices, and associated equipment by vehicle type.	S6.1 Required lamps, reflective devices, and associated equipment by vehicle type.	Table II.
S6.1 Required lamps, reflective devices, and associated equipment by vehicle type.	S6.1 Required lamps, reflective devices, and associated equipment by vehicle type.	Table III.
S6.1 Required lamps, reflective devices, and associated equipment by vehicle type.	S6.1 Required lamps, reflective devices, and associated equipment by vehicle type.	Table IV.
S6.1.1 Quantity	S6.1.1 Quantity	S5.1.1.
S6.1.1 Quantity	S6.1.1 Quantity	S5.1.1.10 Multiple license plate lamps and backup lamps.
S6.1.1 Quantity	S6.1.1 Quantity	Table I.
S6.1.1 Quantity	S6.1.1 Quantity	Table II.
S6.1.1.1 Conspicuity systems	S6.1.1.1 Conspicuity systems	Table III.
S6.1.1.1 Conspicuity systems	S6.1.1.1 Conspicuity systems	Table IV.
S6.1.1.2 High-mounted stop lamp	S6.1.1.2 High mounted stop lamp	S5.7 Conspicuity systems.
S6.1.1.2 High-mounted stop lamp	S6.1.1.2 High mounted stop lamp	S5.7.1 Retroreflective sheeting.
S6.1.1.2 High-mounted stop lamp	S6.1.1.2 High mounted stop lamp	S5.1.1.27(a).
S6.1.1.2 High-mounted stop lamp	S6.1.1.2 High mounted stop lamp	S5.1.1.27(b).
S6.1.1.2 High-mounted stop lamp	S6.1.1.2 High mounted stop lamp	S5.1.1.27(b)(1).
S6.1.1.3 Truck tractor rear double faced turn signal lamps.	S6.1.1.3 Truck tractor rear turn signal lamps ..	S5.3.1.8(b).
S6.1.1.3.1	SAE J588e, Sep 1970, 3.4	S5.1.1.1 Truck tractor exemption; SAE J588e, Sep 1970, 3.9.1.
S6.1.1.4 Daytime running lamps (DRL)	S6.2.4 Daytime running lamps (DRL)	SAE J588e, Sep 1970, 3.4.
S6.1.2 Color	S6.1.2 Color	S5.5.11(a) Daytime running lamps (DRL).
S6.1.2 Color	S6.1.2 Color	S5.1.5.
S6.1.2 Color	S6.1.2 Color	Table I.
S6.1.2 Color	S6.1.2 Color	Table II.
S6.1.2 Color	S6.1.2 Color	Table III.
S6.1.2 Color	S6.1.2 Color	Table IV.
S6.1.3 Mounting location	New title	New title.
S6.1.3.1	S6.1.3 Mounting location and height	Interpretation—King 7/12/00.
S6.1.3.1	S6.1.3 Mounting location and height	S5.3.
S6.1.3.1	S6.1.3 Mounting location and height	Table II.
S6.1.3.1	S6.1.3 Mounting location and height	Table IV.
S6.1.3.2	S6.1.3 Mounting location and height	Interpretation—King 7/12/00.
S6.1.3.2	S6.1.3 Mounting location and height	S5.3.
S6.1.3.2	S6.1.3 Mounting location and height	Table II.
S6.1.3.2	S6.1.3 Mounting location and height	Table IV.
S6.1.3.3 License plate lamp	S6.1.4 License plate lamp	SAE J587, Oct 1981, 6.4.
S6.1.3.5 Headlamp beam mounting	New title	New title.
S6.1.3.5.1 Vertical headlamp arrangement	S8.1.3 Vertical headlamp arrangement	S7.4(b); S7.5(d).
S6.1.3.5.2 Horizontal headlamp arrangement	S8.1.4 Horizontal headlamp arrangement	S7.4(b); S7.5(d).
S6.1.3.5.3 Motorcycle headlamp arrangement ..	S8.1 Headlighting systems	S7.9.1(b).
S6.1.3.6 Auxiliary lamp	S6.2.5 Auxiliary identification lamps	Interpretation—Clarke 7/28/05.
S6.1.4 Mounting height	S6.1.3.1 Mounting height	Table II heading.
S6.1.4 Mounting height	S6.1.3.1 Mounting height	Table IV heading.
S6.1.4.1.1 High-mounted stop lamp mounting ..	S6.1.3.2.1 High mounted stop lamp mounting	S5.3.1.8(a)(2); Interpretation—Nakaya 6/18/85.

APPENDIX B.—FMVSS NO. 108 REWRITE CROSS REFERENCE—Continued

Current FMVSS No. 108 or incorporated document citation	FMVSS No. 108 rewrite NPRM citation	FMVSS No. 108 rewrite final rule citation
S6.1.4.1.2	S7.9.2 Interior mounting	S5.3.1.8(a)(3).
S6.1.4.1.2. High-mounted stop lamp reflections	S6.1.3.2.2. High mounted stop lamp reflections.	S5.3.1.8(a)(3).
S6.1.4.1.3 Accessibility	S7.9.1 High mounted stop lamp design	S5.1.1.27(a)(5).
S6.1.4.1.3 Accessibility	S7.9.1 High mounted stop lamp design	S5.1.1.27(b)(4).
S6.1.5 Activation	S6.1.5 Activation	S5.1.1.11 Stop lamp and turn signal lamp activation interaction.
S6.1.5 Activation	S6.1.5 Activation	S5.5.10(a).
S6.1.5 Activation	S6.1.5 Activation	S5.5.10(b).
S6.1.5 Activation	S6.1.5 Activation	S5.5.10(d).
S6.1.5 Activation	S6.1.5 Activation	S5.5.3.
S6.1.5.1 Hazard warning signal	S6.1.5 Activation	S5.5.7.
S6.1.5.2 Simultaneous beam activation	S6.1.1.4 Hazard warning lamps	S5.5.5.
S6.1.5.2.1	S8.2 Simultaneous beam activation	New title.
S6.1.5.2.2	S8.2 Simultaneous beam activation	S5.5.8.
S6.1.5.2.3	S8.2 Simultaneous beam activation	S5.5.8.
S6.2 Impairment	S8.2 Simultaneous beam activation	S7.4(a)(1)(ii).
S6.2.1 Impairment due to additional lamps or reflective devices.	S6.2 Impairment	New title.
S6.2.1 Impairment due to additional lamps or reflective devices.	S6.2.1 Impairment due to additional lamps or reflective devices.	S5.1.3 Impairment.
S6.2.2 Lamp or reflective device obstructed	S6.2.1 Impairment due to additional lamps or reflective devices.	S5.3.2(a).
S6.2.2 Lamp or reflective device obstructed	S6.2.2 Lamp or reflective device obstructed	Interpretation—Alkire 11/28/89.
S6.2.3 Headlamp obstructions	S6.2.2 Lamp or reflective device obstructed	S5.3.2.2.
S6.2.3.1 Coverings	S14.2 Headlamp obstructions	S7.8.5.
S6.2.3.2 Wipers	S14.2 Headlamp obstructions	S7.8.5.
S6.3 Equipment combinations	S14.2 Headlamp obstructions	S7.8.5.
S6.3.1 High mounted stop lamp and cargo lamp.	S6.3 Equipment combinations	S5.4 Equipment combinations.
S6.3.2 Optically combined HSML and cargo lamp prohibition.	S6.3.1 High mounted stop lamp and cargo lamp.	S5.4(a).
S6.3.3 Clearance lamp and taillamp	S6.3.2 Optically combined HSML and cargo lamp prohibition.	S5.4(b).
S6.4 Lens area, visibility, and aiming	S6.3.3 Clearance lamp and taillamp	S5.4(c).
S6.4.1 Effective projected luminous lens area requirements.	S6.4 Visibility, and aiming	New title.
S6.4.1 Effective projected luminous lens area requirements.	S6.4.1 Effective projected luminous lens area requirements.	S5.1.1.22 Motor driven cycle stop lamp exemptions.
S6.4.1 Effective projected luminous lens area requirements.	S6.4.1 Effective projected luminous lens area requirements.	S5.1.1.25 Motorcycle turn signal lamp EPLLA.
S6.4.1 Effective projected luminous lens area requirements.	S6.4.1 Effective projected luminous lens area requirements.	S5.1.1.26(a).
S6.4.1 Effective projected luminous lens area requirements.	S6.4.1 Effective projected luminous lens area requirements.	S5.1.1.26(b).
S6.4.1 Effective projected luminous lens area requirements.	S6.4.1 Effective projected luminous lens area requirements.	S5.1.1.27(a)(1).
S6.4.1 Effective projected luminous lens area requirements.	S6.4.1 Effective projected luminous lens area requirements.	S5.1.1.27(b)(1).
S6.4.1 Effective projected luminous lens area requirements.	S6.4.1 Effective projected luminous lens area requirements.	SAE J887, Jul 1964.
S6.4.2 Visibility	S6.4.2 Visibility	S5.3.2(c).
S6.4.2 Visibility	S6.4.2 Visibility	S5.3.2(d).
S6.4.2 Visibility	S6.4.2 Visibility	S5.3.2(e).
S6.4.2 Visibility	S6.4.2 Visibility	SAE J887, Jul 1964.
S6.4.3 Visibility requirement options	S6.4.3 Visibility options	S5.3.2(b).
S6.4.3(a) Lens area option	S6.4.3(a) Lens area option	S5.3.2(b)(1).
S6.4.3(b) Luminous intensity option	S6.4.3(b) Luminous intensity option	S5.3.2(b)(2).
S6.4.4 Legacy visibility option	S6.4.4 SAE visibility alternative to S6.4.3	S5.3.2.4.
S6.4.5 School bus signal lamp aiming	S6.4.6 School bus signal lamp aiming	SAE J887, Jul 1964.
S6.5 Marking	S6.5 Marking	New title.
S6.5.1 DOT marking	S6.5.1 DOT marking	S7.2(a).
S6.5.1.1 DOT marking—conspicuity sheeting	S6.5.1 DOT marking	S7.2(e).
S6.5.1.2 DOT marking—except headlamps	S6.5.1.1 DOT marking—conspicuity sheeting	S5.7.1.5 Certification.
S6.5.2 DRL marking	S6.5.1.2 DOT marking—except headlamps	S5.8.10.
S6.5.3 Headlamp markings	S6.5.2 DRL marking	S5.5.11(a)(2).
S6.5.3.1 Trademark	S17 Headlamp marking requirements	Various.
S6.5.3.2 Voltage and trade number	S17.1 Trademark	S7.2(b).
S6.5.3.3 Sealed beam headlamp markings	S17.2 Voltage and trade number	S7.2(c).
S6.5.3.3 Sealed beam headlamp markings	S17.3 Sealed beam headlamp markings	S5.2.2.
S6.5.3.3 Sealed beam headlamp markings	S17.3 Sealed beam headlamp markings	S5.8.2.
S6.5.3.3 Sealed beam headlamp markings	S17.3 Sealed beam headlamp markings	S7.3.1.
S6.5.3.3 Sealed beam headlamp markings	S17.3 Sealed beam headlamp markings	S7.3.7(f).
S6.5.3.3 Sealed beam headlamp markings	S17.3 Sealed beam headlamp markings	S7.3.8(f).

APPENDIX B.—FMVSS NO. 108 REWRITE CROSS REFERENCE—Continued

Current FMVSS No. 108 or incorporated document citation	FMVSS No. 108 rewrite NPRM citation	FMVSS No. 108 rewrite final rule citation
S6.5.3.3 Sealed beam headlamp markings	S17.3 Sealed beam headlamp markings	S7.3.9(c).
S6.5.3.3 Sealed beam headlamp markings	S17.3 Sealed beam headlamp markings	SAE J1383, Apr 1985, 2.1.1.
S6.5.3.3 Sealed beam headlamp markings	S17.3 Sealed beam headlamp markings	SAE J1383, Apr 1985, 5.3.3.
S6.5.3.3 Sealed beam headlamp markings	S17.3 Sealed beam headlamp markings	SAE J1383, Apr 1985, 5.4.3.
S6.5.3.3 Sealed beam headlamp markings	S17.3 Sealed beam headlamp markings	SAE J1383, Apr 1985, 5.4.4.
S6.5.3.3 Sealed beam headlamp markings	S17.3 Sealed beam headlamp markings	SAE J1383, Apr 1985, 5.4.4.1.
S6.5.3.3 Sealed beam headlamp markings	S17.3 Sealed beam headlamp markings	SAE J1383, Apr 1985, 5.4.4.2.
S6.5.3.3 Sealed beam headlamp markings	S17.3 Sealed beam headlamp markings	SAE J1383, Apr 1985, 5.4.4.3.
S6.5.3.3 Sealed beam headlamp markings	S17.3 Sealed beam headlamp markings	SAE J1383, Apr 1985, 5.4.5.
S6.5.3.4 Replaceable bulb headlamp markings	S17.4 Replaceable bulb headlamp markings ..	S7.5(g).
S6.5.3.5 Additional headlamp markings	S17.5 Additional headlamp markings	New reference to other sections.
S6.6 Associated equipment	New title	New title.
S6.6.1 All except trailers	S6.6 Associated equipment	S5.1.1; Table I; Table III.
S6.6.2 All except trailers and motorcycles	S6.6 Associated equipment	S5.1.1; Table I; Table III.
S6.6.3 License plate holder	S6.6.1 License plate holder	SAE J587, Oct 1981, 6.1 and 6.2.
S6.7 Replacement equipment	S6.7 Replacement equipment	S5.8.1; S5.8.3; S5.8.4; S5.8.5; S5.8.6; S5.8.7; S5.8.8; S5.8.9.
S6.7.1 General requirements	S6.7.1 General requirements	70 FR 65972.
S6.7.1.1(a)	S6.7.1.1(a)	70 FR 65972.
S6.7.1.1(b)	S6.7.1.1(b)	70 FR 65972.
S6.7.1.2	S6.7.1.2	70 FR 65972.
S6.7.1.3	S6.7.1.3	70 FR 65972.
S6.7.2 Version of this Standard	S6.7.2 Version of this Standard	70 FR 65972.
S7 Signal lamp requirements	S7 Signal lamps, reflective devices, and associated equipment requirements.	New title.
S7.1 Turn signal lamps	S7.1 Turn signal lamps	New title.
S7.1.1 Front turn signal lamps	S7.1.1 Front turn signal lamps	New title.
S7.1.1.1 Number [New section—points to Table I].	New section	New section.
S7.1.1.2 Color of light [New section—points to Table I].	New section	New section.
S7.1.1.3 Mounting location [New section—points to Table I].	New section	New section.
S7.1.1.4 Mounting height [New section—points to Table I].	New section	New section.
S7.1.1.5 Activation [New section—points to Table I].	New section	New section.
S7.1.1.6 Effective projected luminous lens area [New section—points to Table IV—a].	New section	New section.
S7.1.1.7 Visibility [New section—points to S6.4]	New section	New section.
S7.1.1.8 Indicator [New section—points to S9.3]	New section	New section.
S7.1.1.9 Markings [New section—points to S6.5].	New section	New section.
S7.1.1.10 Spacing to other lamps	S7.1.1.2 Spacing to other lamps	SAE J588, Nov 1984, 5.1.5.4.
S7.1.1.10.1	S7.1.1.2 Spacing to other lamps	SAE J588, Nov 1984, 5.1.5.4.
S7.1.1.10.2 Spacing measurement for non-reflector lamps.	S7.1.1.2.1 Spacing measurement for non-reflector lamps.	SAE J588, Nov 1984, 5.1.5.4.1; SAE J1395, Apr 1985, 5.1.5.5.
S7.1.1.10.3 Spacing measurement for lamps with reflectors.	S7.1.1.2.2 Spacing measurement for lamps with reflectors.	SAE J588, Nov 1984, 5.1.5.4.2; SAE J1395, Apr 1985, 5.1.5.6.
S7.1.1.10.4 Spacing based photometric multipliers.	S7.1.1.2.3 Spacing based photometric multipliers.	S5.3.1.7; SAE J588, Nov 1984, Table 2.
S7.1.1.11 Multiple compartments and multiple lamps.	S7.1.1.3 Multiple compartments and multiple lamps.	SAE J588, Nov 1984, 5.1.5.2.
S7.1.1.11.1	S7.1.1.3 Multiple compartments and multiple lamps.	SAE J588, Nov 1984, 5.1.5.2.
S7.1.1.11.2	S7.1.1.3 Multiple compartments and multiple lamps.	SAE J588, Nov 1984, 5.1.5.2.
S7.1.1.11.3	S7.1.1.3 Multiple compartments and multiple lamps.	SAE J588, Nov 1984, 5.1.5.2.
S7.1.1.11.4 Lamps installed on vehicles 2032 mm or more in overall width.	S7.1.1.3.1 Lamps installed on vehicles 2032 mm or more in overall width.	S5.1.1.12.
S7.1.1.12 Ratio to parking lamps and clearance lamps.	S7.1.1.3.2 Ratio to parking lamps and clearance lamps.	SAE J588, Nov 1984, 5.1.5.3; SAE J1395, Apr 1985, 5.1.5.2.
S7.1.1.12.1	S7.1.1.3.2 Ratio to parking lamps and clearance lamps.	SAE J588, Nov 1984, 5.1.5.3; SAE J1395, Apr 1985, 5.1.5.2.
S7.1.1.12.2	S7.1.1.3.2 Ratio to parking lamps and clearance lamps.	SAE J588, Nov 1984, 5.1.5.3; SAE J1395, Apr 1985, 5.1.5.2.
S7.1.1.12.3	S7.1.1.3.2 Ratio to parking lamps and clearance lamps.	SAE J588, Nov 1984, 5.1.5.3; SAE J1395, Apr 1985, 5.1.5.2.
S7.1.1.12.4	S7.1.1.3.2 Ratio to parking lamps and clearance lamps.	SAE J588, Nov 1984, 5.1.5.3; SAE J1395, Apr 1985, 5.1.5.2.

APPENDIX B.—FMVSS NO. 108 REWRITE CROSS REFERENCE—Continued

Current FMVSS No. 108 or incorporated document citation	FMVSS No. 108 rewrite NPRM citation	FMVSS No. 108 rewrite final rule citation
S7.1.1.13 Photometry	S7.1.1.1 Photometry	S5.1.1.7; SAE J588, Nov 1984, Table 1; SAE J1395, Apr 1985, Table 1.
S7.1.1.13.1	S7.1.1.1 Photometry	S5.1.1.7; SAE J588, Nov 1984, Table 1; SAE J1395, Apr 1985, Table 1.
S7.1.1.13.2	S7.1.1.1 Photometry	S5.1.1.7; SAE J588, Nov 1984, Table 1; SAE J1395, Apr 1985, Table 1.
S7.1.1.14 Physical tests	S7.1.3 Physical tests	S5.1.2; S5.1.5; S6.2; SAE J588, Nov 1984, 4; SAE J1395, Apr 1985, 4.
S7.1.2 Rear turn signal lamps	New title	New title.
S7.1.2.1 Number [New section—points to Table I].	New section	New section.
S7.1.2.2 Color of light [New section—points to Table I].	New section	New section.
S7.1.2.3 Mounting location [New section—points to Table I and S6.1.3.2].	New section	New section.
S7.1.2.4 Mounting height [New section—points to Table I].	New section	New section.
S7.1.2.5 Activation [New section—points to Table I].	New section	New section.
S7.1.2.6 Effective projected luminous lens area [New section—points to Table IV—a].	New section	New section.
S7.1.2.7 Visibility [New section—points to S6.4]	New section	New section.
S7.1.2.8 Indicator [New section—points to S9.3].	New section	New section.
S7.1.2.9 Markings [New section—points to S6.5].	New section	New section.
S7.1.2.10 Spacing to other lamps [New section—No requirement].	New section	New section.
S7.1.2.11 Multiple compartments and multiple lamps.	S7.1.2.2 Multiple compartments and multiple lamps.	SAE J588, Nov 1984, 5.1.5.2.
S7.1.2.11.1	S7.1.2.2 Multiple compartments and multiple lamps.	SAE J588, Nov 1984, 5.1.5.2.
S7.1.2.11.2	S7.1.2.2 Multiple compartments and multiple lamps.	SAE J588, Nov 1984, 5.1.5.2.
S7.1.2.11.3	S7.1.2.2 Multiple compartments and multiple lamps.	SAE J588, Nov 1984, 5.1.5.2.
S7.1.2.11.4 Lamps installed on vehicles 2032 mm or more in overall width.	S7.1.2.2.1 Lamps installed on vehicles 2032 mm or more in overall width.	S5.1.1.12.
S7.1.2.12 Ratio to taillamps and clearance lamps.	S7.1.2.3 Ratio to taillamps and clearance lamps.	SAE J588, Nov 1984, 5.1.5.3; SAE J1395, Apr 1985, Table 1.
S7.1.2.12.1	S7.1.2.3 Ratio to taillamps and clearance lamps.	SAE J588, Nov 1984, 5.1.5.3; SAE J1395, Apr 1985, Table 1.
S7.1.2.12.2	S7.1.2.3 Ratio to taillamps and clearance lamps.	SAE J588, Nov 1984, 5.1.5.3.
S7.1.2.12.3	S7.1.2.3 Ratio to taillamps and clearance lamps.	SAE J588, Nov 1984, 5.1.5.3.
S7.1.2.12.4	S7.1.2.3 Ratio to taillamps and clearance lamps.	SAE J588, Nov 1984, 5.1.5.3; SAE J1395, Apr 1985, Table 1.
S7.1.2.13 Photometry	S7.1.2.1 Photometry	SAE J588, Nov 1984, Table 1; SAE J1395, Apr 1985, Table 1.
S7.1.2.13.1	S7.1.2.1 Photometry	SAE J588, Nov 1984, Table 1; SAE J1395, Apr 1985, Table 1.
S7.1.2.13.2 Motorcycle alternative	S7.1.2.1 Photometry	S5.1.1.7 Motorcycle turn signal lamp.
S7.1.2.14 Physical tests	S7.1.3 Physical tests	S5.1.2; S5.1.5; S6.2; SAE J588, Nov 1984, 4; SAE J1395, Apr 1985, 5.3.1.
S7.1.3 Combined lamp bulb indexing	S7.1.4 Combined lamp bulb indexing	SAE J588, Nov 1984, 5.3.1; SAE J1395, Apr 1985, 5.3.1.
S7.1.3.1 Dual filament bulbs	S7.1.4 Combined lamp bulb indexing	SAE J588, Nov 1984, 5.3.1; SAE J1395, Apr 1985, 5.3.1.
S7.1.3.2 Socket indexing	S7.1.4 Combined lamp bulb indexing	SAE J588, Nov 1984, 5.3.1; SAE J1395, Apr 1985, 5.3.1.
S7.2 Taillamps	New section	New section.
S7.2.1 Number [New section—points to Table I].	New section	New section.
S7.2.2 Color of light [New section—points to Table I].	New section	New section.
S7.2.3 Mounting location [New section—points to Table I and S6.1.3.2].	New section	New section.
S7.2.4 Mounting height [New section—points to Table I].	New section	New section.

APPENDIX B.—FMVSS NO. 108 REWRITE CROSS REFERENCE—Continued

Current FMVSS No. 108 or incorporated document citation	FMVSS No. 108 rewrite NPRM citation	FMVSS No. 108 rewrite final rule citation
S7.2.4 Mounting height [New section—points to Table I].	New section	New section.
S7.2.5 Activation [New section—points to Table I].	New section	New section.
S7.2.6 Effective projected luminous lens area [New section—No requirement].	New section	New section.
S7.2.7 Visibility [New section—points to S6.4] ..	New section	New section.
S7.2.8 Indicator [New section—No requirement].	New section	New section.
S7.2.9 Markings [New section—points to S6.5]	New section	New section.
S7.2.10 Spacing to other lamps [New section—No requirement].	New section	New section.
S7.2.11 Multiple compartments and multiple lamps.	S7.2.1.1 Multiple compartments and multiple lamps.	SAE J585e, Sep 1977, 3.1.
S7.2.11.1	S7.2.1.1 Multiple compartments and multiple lamps.	SAE J585e, Sep 1977, 3.1.
S7.2.11.2	S7.2.1.1 Multiple compartments and multiple lamps.	SAE J585e, Sep 1977, 3.1.
S7.2.11.3	S7.2.1.1 Multiple compartments and multiple lamps.	SAE J585e, Sep 1977, 3.1.
S7.2.11.4 Taillamps installed on vehicles 2032 mm. or more in overall width.	S7.2.1.1.1 Lamps installed on vehicles 2032 mm or more in overall width.	SAE J585e, Sep 1977, 3.1.
S7.2.12 Ratio [New section—points to S7.1.2.12 and 7.3.12].	New section	New section.
S7.2.13 Photometry	S7.2.1 Photometry	S5.1.1.6; Figure 1a; Figure 1b; Figure 1c.
S7.2.14 Physical tests	S7.2.2 Physical tests	S5.1.2; S5.1.5; S6.2; SAE J585e, Sep 1977, 3.
S7.3 Stop lamps	New section	New section.
S7.3.1 Number [New section—points to Table I].	New section	New section.
S7.3.2 Color of light [New section—points to Table I].	New section	New section.
S7.3.3 Mounting location [New section—points to Table I and S6.1.3.2].	New section	New section.
S7.3.4 Mounting height [New section—points to Table I].	New section	New section.
S7.3.5 Activation [New section—points to Table I].	New section	New section.
S7.3.6 Effective projected luminous lens area [New section—points to Table IV—a].	New section	New section.
S7.3.7 Visibility [New section—points to S6.4] ..	New section	New section.
S7.3.8 Indicator [New section—No requirement].	New section	New section.
S7.3.9 Markings [New section—points to S6.5]	New section	New section.
S7.3.10 Spacing to other lamps [New section—No requirement].	New section	New section.
S7.3.11 Multiple compartments and multiple lamps.	S7.3.1.1 Multiple compartments and multiple lamps.	SAE J586, Feb 1984, 5.1.5.2.
S7.3.11.1	S7.3.1.1 Multiple compartments and multiple lamps.	SAE J586, Feb 1984, 5.1.5.2.
S7.3.11.2	S7.3.1.1 Multiple compartments and multiple lamps.	SAE J586, Feb 1984, 5.1.5.2.
S7.3.11.3	S7.3.1.1 Multiple compartments and multiple lamps.	SAE J586, Feb 1984, 5.1.5.2.
S7.3.11.4 Lamps installed on vehicles 2032 mm or more in overall width.	S7.3.1.1.1 Lamps installed on vehicles 2032 mm or more in overall width.	S5.1.1.12.
S7.3.12 Ratio to taillamps	S7.3.1.2 Ratio to taillamps	SAE J586, Feb 1984, 5.1.5.3; SAE J1398, May 1985, 5.1.5.2.
S7.3.12.1	S7.3.1.2 Ratio to taillamps	SAE J586, Feb 1984, 5.1.5.3; SAE J1398, May 1985, 5.1.5.2.
S7.3.12.2	S7.3.1.2 Ratio to taillamps	SAE J586, Feb 1984, 5.1.5.3; SAE J1398, May 1985, 5.1.5.2.
S7.3.12.3	S7.3.1.2 Ratio to taillamps	SAE J586, Feb 1984, 5.1.5.3; SAE J1398, May 1985, 5.1.5.2.
S7.3.12.4	S7.3.1.2 Ratio to taillamps	SAE J586, Feb 1984, 5.1.5.3; SAE J1398, May 1985, 5.1.5.2.
S7.3.13 Photometry	S7.3.1 Photometry	SAE J586, Feb 1984, Table 1; SAE J1398, May 1985, Table 1.
S7.3.13.1	S7.3.1 Photometry	SAE J586, Feb 1984, Table 1; SAE J1398, May 1985, Table 1.

APPENDIX B.—FMVSS NO. 108 REWRITE CROSS REFERENCE—Continued

Current FMVSS No. 108 or incorporated document citation	FMVSS No. 108 rewrite NPRM citation	FMVSS No. 108 rewrite final rule citation
S7.3.13.2 Motor driven cycle alternative	S7.3.1 Photometry	S5.1.1.22 Motor driven cycle stop lamp exemptions.
S7.3.14 Physical tests	S7.3.2 Physical tests	S5.1.2; S5.1.5; S6.2; SAE J586, Feb 1984, 5; SAE J1398, May 1985, 5.
S7.3.15 Combined lamp bulb indexing	S7.3.3 Combined lamp bulb indexing	SAE J586, Feb 1984, 5.3.1; SAE J1398, May 1985, 5.3.1.
S7.3.15.1 Dual filament bulbs	S7.3.3 Combined lamp bulb indexing	SAE J586, Feb 1984, 5.3.1; SAE J1398, May 1985, 5.3.1.
S7.3.15.2 Socket indexing	S7.3.3 Combined lamp bulb indexing	SAE J586, Feb 1984, 5.3.1; SAE J1398, May 1985, 5.3.1.
S7.4 Side marker lamps	New section	New section.
S7.4.1 Number [New section—points to Table I].	New section	New section.
S7.4.2 Color of light [New section—points to Table I].	New section	New section.
S7.4.3 Mounting location [New section—points to Table I].	New section	New section.
S7.4.5 Activation [New section—points to Table I].	New section	New section.
S7.4.6 Effective projected luminous lens area [New section—No requirement].	New section	New section.
S7.4.7 Visibility [New section—No requirement]	New section	New section.
S7.4.8 Indicator [New section—No requirement].	New section	New section.
S7.4.9 Markings [New section—points to S6.5]	New section	New section.
S7.4.10 Spacing to other lamps [New section—No requirement].	New section	New section.
S7.4.11 Multiple compartments and multiple lamps [New section—No requirement].	New section	New section.
S7.4.12 Ratio [New section—No requirement] ..	New section	New section.
S7.4.13 Photometry	S7.4.1 Photometry	SAE J592e, Jul 1972, Table 1.
S7.4.13.1	S7.4.1 Photometry	SAE J592e, Jul 1972, Table 1.
S7.4.13.2 Inboard photometry	S7.4.1.1 Inboard photometry	S5.1.1.3; S5.1.1.8; SAE J592e, Jul 1972, Table 1, footnote b.
S7.4.14 Physical tests	S7.4.2 Physical tests	S5.1.2; S5.1.5; S6.2; SAE J592e, Jul 1972, 3.
S7.5 Clearance and identification lamps	New section	New section.
S7.5.1 Number [New section—points to Table I].	New section	New section.
S7.5.2 Color of light [New section—points to Table I].	New section	New section.
S7.5.3 Mounting location [New section—points to Table I].	New section	New section.
S7.5.4 Mounting height [New section—points to Table I].	New section	New section.
S7.5.5 Activation [New section—points to Table I].	New section	New section.
S7.5.6 Effective projected luminous lens area [New section—No requirement].	New section	New section.
S7.5.7 Visibility [New section—No requirement]	New section	New section.
S7.5.8 Indicator [New section—No requirement].	New section	New section.
S7.5.9 Markings [New section—points to S6.5]	New section	New section.
S7.5.10 Spacing to other lamps [New section—No requirement].	New section	New section.
S7.5.11 Multiple compartments and multiple lamps [New section—No requirement].	New section	New section.
S7.5.12 Ratio	New section	New section.
S7.5.12.1 Clearance lamps [New section—points to S7.1.1.12 and S7.1.2.12].	New section	New section.
S7.5.12.2 Identification lamps [New section—No requirement].	New section	New section.
S7.5.13 Photometry	S7.5.1 Photometry	SAE J592e, Jul 1972, Table 1.
S7.5.14 Physical tests	S7.5.2 Physical tests	S5.1.2; S5.1.5; S6.2; SAE J592e, Jul 1972, 3.
S7.6 Backup lamps	New section	New section.
S7.6.1 Number [New section—points to Table I].	New section	New section.
S7.6.2 Color of light	New section	New section.
S7.6.2.1 [New section—points to Table I]	New section	New section.
S7.6.2.2 Incidental light	S7.6.2 Color	SAE J593c, Feb 1968.
S7.6.3 Mounting location [New section—points to Table I].	New section	New section.

APPENDIX B.—FMVSS NO. 108 REWRITE CROSS REFERENCE—Continued

Current FMVSS No. 108 or incorporated document citation	FMVSS No. 108 rewrite NPRM citation	FMVSS No. 108 rewrite final rule citation
S7.6.4 Mounting height [New section—No requirement].	New section	New section.
S7.6.5 Activation [New section—points to Table I].	New section	New section.
S7.6.6 Effective projected luminous lens area [New section—No requirement].	New section	New section.
S7.6.7 Visibility [New section—see Table V—a]	New section	New section.
S7.6.8 Indicator [New section—No requirement].	New section	New section.
S7.6.9 Markings [New section—points to S6.5]	New section	New section.
S7.6.10 Spacing to other lamps [New section—No requirement].	New section	New section.
S7.6.11 Multiple compartments and multiple lamps [New section—No requirement].	New section	New section.
S7.6.12 Ratio [New section—No requirement] ..	New section	New section.
S7.6.13 Photometry	S7.6.1 Photometry	Figure 2.
S7.6.14 Physical tests	S7.6.3 Physical tests	S5.1.2; S5.1.5; S6.2; SAE J593c, Feb 1968.
S7.7 License plate lamps	New section	New section.
S7.7.1 Number [New section—points to Table I and S6.1.1].	New section	New section.
S7.7.2 Color of light [New section—points to Table I].	New section	New section.
S7.7.3 Mounting location [New section—points to Table I].	New section	New section.
S7.7.4 Mounting height [New section—No requirement].	New section	New section.
S7.7.5 Activation [New section—points to Table I].	New section	New section.
S7.7.6 Effective projected luminous lens area [New section—No requirement].	New section	New section.
S7.7.7 Visibility [New section—No requirement]	New section	New section.
S7.7.8 Indicator [New section—No requirement].	New section	New section.
S7.7.9 Markings [New section—points to S6.5]	New section	New section.
S7.7.10 Spacing to other lamps [New section—No requirement].	New section	New section.
S7.7.11 Multiple compartments and multiple lamps [New section—No requirement].	New section	New section.
S7.7.12 Ratio [New section—No requirement] ..	New section	New section.
S7.7.13 Photometry	S7.7.2 Photometry requirements	SAE J587, Oct 1981, 7.
S7.7.13. Ratio—motorcycles and motor driven cycles.	S7.7.2 Photometry requirements	SAE J587, Oct 1981, 7.
S7.7.13.1	S7.7.2 Photometry requirements	SAE J587, Oct 1981, 7.
S7.7.13.2 Illumination	S7.7.2 Photometry requirements	SAE J587, Oct 1981, 7.
S7.7.13.3 Ratio except motorcycles and motor driven cycles.	S7.7.2 Photometry requirements	SAE J587, Oct 1981, 7.
S7.7.14 Physical tests	S7.7.3 Physical tests	S5.1.2; S5.1.5; S6.2; SAE J587, Oct 1981, 3, 4, and 5.
S7.7.15 Installation	New section	New section.
S7.7.15.1	S7.7.1 Installation	SAE J587, Oct 1981, 6.3.
S7.7.15.2	S7.7.1 Installation	SAE J587, Oct 1981, 6.3.
S7.7.15.3	S7.7.1 Installation	SAE J587, Oct 1981, 6.3.
S7.7.15.4 Incident light from a single lamp	S7.7.1.1 Incident light from a single lamp	SAE J587, Oct 1981, 6.5.
S7.7.15.5 Incident light from multiple lamps	S7.7.1.2 Incident light from multiple lamps	SAE J587, Oct 1981, 6.6.
S7.8 Parking lamps	New section	New section.
S7.8.1 Number [New section—points to Table I].	New section	New section.
S7.8.2 Color of light [New section—points to Table I].	New section	New section.
S7.8.3 Mounting location [New section—points to Table I].	New section	New section.
S7.8.4 Mounting height [New section—points to Table I].	New section	New section.
S7.8.5 Activation [New section—points to Table I].	New section	New section.
S7.8.6 Effective projected luminous lens area [New section—No requirement].	New section	New section.
S7.8.7 Visibility [New section—points to S6.4] ..	New section	New section.
S7.8.8 Indicator [New section—No requirement].	New section	New section.
S7.8.9 Markings [New section—points to S6.5]	New section	New section.

APPENDIX B.—FMVSS NO. 108 REWRITE CROSS REFERENCE—Continued

Current FMVSS No. 108 or incorporated document citation	FMVSS No. 108 rewrite NPRM citation	FMVSS No. 108 rewrite final rule citation
S7.8.10 Spacing to other lamps [New section—No requirement].	New section	New section.
S7.8.11 Multiple compartments and multiple lamps [New section—No requirement].	New section	New section.
S7.8.12 Ratio [New section—points to S7.1.1.12].	New section	New section.
S7.8.13 Photometry	S7.8.1 Photometry	S5.1.1.6; Figure 1a; Figure 1b; Figure 1c.
S7.8.14 Physical tests	S7.8.2 Physical tests	S5.1.2; S5.1.5; S6.2; SAE J222, Dec 1970, 3.
S7.9 High-mounted lamps	New section	New section.
S7.9.1 Number [New section—points to Table I and S6.1.1.2].	New section	New section.
S7.9.2 Color of light [New section—points to Table I].	New section	New section.
S7.9.3 Mounting location [New section—points to Table I].	New section	New section.
S7.9.4 Mounting height [New section—points to Table I and S6.1.4.1].	New section	New section.
S7.9.5 Activation [New section—points to Table I].	New section	New section.
S7.9.6 Effective projected luminous lens area [New section—points to Table IV—b].	New section	New section.
S7.9.7 Visibility [New section—points to Table V—a].	New section	New section.
S7.9.8 Indicator [New section—No requirement].	New section	New section.
S7.9.9 Markings [New section—points to S6.5]	New section	New section.
S7.9.10 Spacing to other lamps [New section—No requirement].	New section	New section.
S7.9.11 Multiple compartments and multiple lamps [New section—No requirement].	New section	New section.
S7.9.12 Ratio [New section—No requirement] ..	New section	New section.
S7.9.13 Photometry	S7.9.3 Photometry	S5.1.1.27(a)(3) and (b)(3); Figure 10.
S7.9.14 Physical tests	S7.9.4 Physical tests	S5.1.1.27(a)(4); S5.1.2; S5.1.5; S6.2; SAE J186a, Sep 1977, 3.
S7.9.14.1 External mount	S7.9.4 Physical tests	S5.1.1.27(a)(4); S5.1.2; S5.1.5; S6.2; SAE J186a, Sep 1977, 3.
S7.9.14.2 Internal mount	S7.9.4 Physical tests	S5.1.1.27(a)(4); S5.1.2; S5.1.5; S6.2; SAE J186a, Sep 1977, 3.
S7.10 Daytime running lamps (DRLs)	New section	New section.
S7.10.1 Number [New section—points to Table I].	New section	New section.
S7.10.2 Color of light [New section—points to Table I].	New section	New section.
S7.10.3 Mounting location [New section—points to Table I].	New section	New section.
S7.10.4 Mounting height [New section—points to Table I and S7.10.13(b)].	New section	New section.
S7.10.5 Activation [New section—points to Table I and S7.10.10.1(c)].	New section	New section.
S7.10.6 Effective projected luminous lens area [New section—No requirement].	New section	New section.
S7.10.7 Visibility [New section—No requirement].	New section	New section.
S7.10.8 Indicator [New section—No requirement].	New section	New section.
S7.10.9 Markings [New section—points to S6.5].	New section	New section.
S7.10.10 Spacing to other lamps	S7.11.2 Spacing to turn signal lamps	S5.5.11(a)(4).
S7.10.10.1(a)	S7.11.2.2(a) Not optically combined with turn signal lamp.	S5.5.11(a)(4)(i).
S7.10.10.1(b)	S7.11.2.2(b) Not optically combined with turn signal lamp.	S5.5.11(a)(4)(iii).
S7.10.10.1(c)	S7.11.2.2(c) Not optically combined with turn signal lamp.	S5.5.11(a)(4)(iv).
S7.10.11 Multiple compartments and multiple lamps [New section—No requirement].	New section	New section.
S7.10.12 Ratio [New section—No requirement]	New section	New section.
S7.10.13 Photometry	S7.11.1 Photometry	S5.5.11(a)(1).
S7.10.13(a)	S7.11.1(a)	S5.5.11(a)(1)(i).
S7.10.13(b)	S7.11.1(b)	S5.5.11(a)(1)(ii).
S7.10.14 Physical tests	S7.11.3 Physical tests	S5.1.2; S5.1.5; S5.5.11(a)(3); S6.2.

APPENDIX B.—FMVSS NO. 108 REWRITE CROSS REFERENCE—Continued

Current FMVSS No. 108 or incorporated document citation	FMVSS No. 108 rewrite NPRM citation	FMVSS No. 108 rewrite final rule citation
S7.11 School bus signal lamps	New section	New section.
S7.11.1 Number [New section—points to Table I].	New section	New section.
S7.11.2 Color of light [New section—points to Table I].	New section	New section.
S7.11.3 Mounting location [New section—points to Table I].	New section	New section.
S7.11.4 Mounting height [New section—points to Table I].	New section	New section.
S7.11.5 Activation [New section—points to Table I].	New section	New section.
S7.11.6 Effective projected luminous lens area [New section—points to Table IV—c].	New section	New section.
S7.11.7 Visibility [New section—points to Table V—a].	New section	New section.
S7.11.8 Indicator [New section—No requirement].	New section	New section.
S7.11.9 Markings [New section—points to S6.5].	New section	New section.
S7.11.10 Spacing to other lamps [New section—No requirement].	New section	New section.
S7.11.11 Multiple compartments and multiple lamps [New section—No requirement].	New section	New section.
S7.11.12 Ratio [New section—No requirement]	New section	New section.
S7.11.13 Photometry	S7.13.1 Photometry	S5.1.4(b); SAE J887, Jul 1964, Table 1.
S7.11.14 Physical tests	S7.13.2 Physical test requirements	S5.1.2; S5.1.5; S6.2; SAE J887, Jul 1964.
S8.1 Reflex reflectors	S7.10 Reflex reflectors	New title.
S8.1.1 Number [New section—points to Table I].	New section	New section.
S8.1.2 Color [New section—points to Table I] ..	New section	New section.
S8.1.3 Mounting location [New section—points to Table I].	New section	New section.
S8.1.4 Mounting height [New section—points to Table I].	New section	New section.
S8.1.5 Activation [New section—No requirement].	New section	New section.
S8.1.6 Effective projected luminous lens area [New section—No requirement].	New section	New section.
S8.1.7 Visibility [New section—No requirement]	New section	New section.
S8.1.8 Indicator [New section—No requirement].	New section	New section.
S8.1.9 Markings [New section—points to S6.5]	New section	New section.
S8.1.10 Spacing to other lamps [New section—No requirement].	New section	New section.
S8.1.11 Photometry	S7.10.1 Photometry	SAE J594f, Jan 1977, Table 1 and Table 1A.
S8.1.12 Physical tests	S7.10.2 Physical tests	S5.1.2; S5.1.5; S6.2; SAE J594f, Jan 1977, 3.
S8.1.13 Alternative side reflex reflector material	S7.10.1.1 Alternative side reflex reflectors	S5.1.1.4 Alternative side reflex material: SAE J594f, Jan 1977, Table 1 and Table 1A.
S8.2 Conspicuity systems	S7.12 Conspicuity systems	S5.7.3 Combination of sheeting and reflectors.
S8.2.1 Retroreflective sheeting	S7.12.1 Retroreflective sheeting	S5.7.1 Retroreflective sheeting.
S8.2.1.1 Construction	S7.12.1 Retroreflective sheeting	S5.7.1.1 Construction.
S8.2.1.2 Performance requirements	S7.12.1 Retroreflective sheeting	S5.7.1.2; S5.7.1.3(d).
S8.2.1.3 Certification marking	S7.12.1.1 Certification marking	S5.7.1.5 Certification.
S8.2.1.4 Application pattern	Table III Application pattern	New title.
S8.2.1.4.1 Alternating red and white materials	Table III Application pattern—Alternating—Retroreflective sheeting.	S5.7.1.3 Sheeting pattern, dimensions, and relative coefficients of retroreflection.
S8.2.1.4.1.1 Segments	Table III Application pattern—Alternating—Retroreflective sheeting.	S5.7.1.3(b).
S8.2.1.4.1.2 Proportion	Table III Application pattern—Alternating—Retroreflective sheeting.	S5.7.1.3(c).
S8.2.1.5 Application location	Table III Application location—Retroreflective sheeting.	S5.7.1.4(a).
S8.2.1.6 Application spacing	Table III Application spacing—Retroreflective sheeting.	S5.7.1.4(b) and (c).
S8.2.1.7 Photometry	S7.12.1.2 Photometry	S5.7.1.2; Figure 29.
S8.2.2 Conspicuity reflex reflectors	S7.12.2 Conspicuity reflex reflectors	S5.7.2 Reflex reflectors.
S8.2.2.1 Certification marking	S7.12.2.1 Certification marking	S5.7.2.3 Certification.
S8.2.2.2 Application pattern	Table III Application pattern	S5.7.2.2.
S8.2.2.2.1 Alternating red and white materials	Table III Application pattern—Alternating—Conspicuity reflex reflectors.	S5.7.2.2(a).

APPENDIX B.—FMVSS NO. 108 REWRITE CROSS REFERENCE—Continued

Current FMVSS No. 108 or incorporated document citation	FMVSS No. 108 rewrite NPRM citation	FMVSS No. 108 rewrite final rule citation
S8.2.2.2.2 White material	Table III Application pattern—White—Conspicuity reflex reflectors.	S5.7.2.2(b).
S8.2.2.3 Photometry	S7.12.2.2 Photometry	S5.7.2.1.
S8.2.2.3.1 Red reflectors	S7.12.2.2 Photometry	S5.7.2.1(a) and (b).
S8.2.2.3.2 White reflectors—horizontal orientation.	S7.12.2.2 Photometry	S5.7.2.1(a) and (c).
S8.2.2.3.3 White reflectors—vertical orientation	S7.12.2.2 Photometry	S5.7.2.1(a) and (d).
S8.2.3 Conspicuity system installation on trailers.	Table III Trailer rear	New title.
S8.2.3.1 Trailer rear	Table III Trailer rear	S5.7.1.4.1 Rear of trailers.
S8.2.3.1.1 Element 1—alternating red and white materials.	Table III Trailer rear—Element 1—Alternating	S5.7.1.4.1(a).
S8.2.3.1.2 Element 2—white & Exceptions.	Table III Trailer rear—Element 2—White	S5.7.1.4.1 Rear of trailers.
S8.2.3.1.2.1 Upper corners	Table III Trailer rear—Element 2—White—requirement.	S5.7.1.4.1(b).
S8.2.3.1.2.2 Non-rectangular body	Table III Trailer rear—Element 2—White—requirement.	S5.7.1.4.1(b).
S8.2.3.1.3 Element 3—alternating red and white materials & Exceptions.	Table III Trailer rear—Element 3—Alternating	S5.7.1.4.1 Rear of trailers.
S8.2.3.1.3.1 Underride device	Table III Trailer rear—Element 3—Alternating—requirement.	S5.7.1.4.1(c).
S8.2.3.2 Trailer side—alternating red and white materials.	Table III Trailer side—Alternating	S5.7.1.4.2 Side of trailers.
S8.2.3.2.1 Horizontal strip	Table III Trailer side—Alternating—requirement.	S5.7.1.4.2(a).
S8.2.3.2.2 Non-continuous	Table III Trailer side—Alternating—requirement.	S5.7.1.4.2(a).
S8.2.3.2.3 Obstructions	Table III Trailer side—Alternating—requirement.	S5.7.1.4.2(b).
S8.2.4 Conspicuity system installation on truck tractors.	Table III Truck tractor	S5.7.1.4.3 Rear of truck tractors.
S8.2.4.1 Element 1—alternating red and white materials.	Table III Truck tractor—Element 1—Alternating.	S5.7.1.4.3 Rear of truck tractors.
S8.2.4.1.1 Lower horizontal	Table III Truck tractor—Element 1—Alternating—requirement.	S5.7.1.4.3(a).
S8.2.4.1.2 Mudflap mounting	Table III Truck tractor—Element 1—Alternating—requirement.	S5.7.1.4.3(a).
S8.2.4.1.3 Mounting alternatives	Table III Truck tractor—Element 1—Alternating—requirement.	S5.7.1.4.3(a).
S8.2.4.1.4 Obstruction	Table III Truck tractor—Element 1—Alternating—requirement.	S5.7.1.4.3(a).
S8.2.4.2 Element 2—white	Table III Truck tractor—Element 2—White	S5.7.1.4.3(b).
S8.2.4.2.1 Obstruction	Table III Truck tractor—Element 2—White—requirement.	S5.7.1.4.3(b).
S8.2.4.2.2 Symmetrical relocation	Table III Truck tractor—Element 2—White—requirement.	S5.7.1.4.3(b).
S8.2.4.2.3 Window mounting	Table III Truck tractor—Element 2—White—requirement.	S5.7.1.4.3(b).
S9 Associated equipment requirements	S7.14 Associated equipment	Table I and Table III.
S9.1 Turn signal operating unit	New title	New title.
S9.1.1 Canceling	S7.14.1 Turn signal operating unit	S5.1.1.5.
S9.1.2 Physical tests	Table XXI	SAE J589, Apr 1964.
S9.2 Turn signal flasher	New title	New title.
S9.2.1 Indicator signals	S7.14.2 Turn signal flasher	SAE J590b, Oct 1965.
S9.2.2 Physical tests	Table XXI	SAE J590b, Oct 1965.
S9.3 Turn signal pilot indicator	S7.14.3 Turn signal pilot indicator	S5.5.6; SAE J588e, Sep 1970.
S9.3.1 TS lamps not visible	S7.14.3 Turn signal pilot indicator	S5.5.6; SAE J588e, Sep 1970.
S9.3.2 Indicator light(s)	S7.14.3 Turn signal pilot indicator	S5.5.6; SAE J588e, Sep 1970.
S9.3.3 Function	S7.14.3 Turn signal pilot indicator	S5.5.6; SAE J588e, Sep 1970.
S9.3.4 Indicator size and color	S7.14.3.1 Indicator size and color	SAE J588e, Sep 1970.
S9.3.4.1 Interior mounted	S7.14.3.1 Indicator size and color	SAE J588e, Sep 1970.
S9.3.4.2 Exterior mounted	S7.14.3.1 Indicator size and color	SAE J588e, Sep 1970.
S9.3.5 Visibility	S7.14.3.1 Indicator size and color	SAE J588e, Sep 1970.
S9.3.6 Turn signal lamp failure	S7.14.3.2 Turn signal lamp failure	S5.5.6.
S9.4 Headlamp beam switching device	S7.14.4 Headlamp beam switching device	S5.5.1 Headlamp beam switching.
S9.4 Headlamp beam switching device	S7.14.4 Headlamp beam switching device	SAE J564a, Apr 1964.
S9.4.1 Semi-automatic headlamp beam switching device.	S7.14.4.1 Semi-automatic headlamp beam switching device.	S5.5.1 Headlamp beam switching.
S9.4.1 Semi-automatic headlamp beam switching device.	S7.14.4.1 Semi-automatic headlamp beam switching device.	SAE J565b, Feb 1969.
S9.4.1.1 Operating instructions	S7.14.4.1.1 Operating instructions	SAE J565b, Feb 1969, 2.

APPENDIX B.—FMVSS NO. 108 REWRITE CROSS REFERENCE—Continued

Current FMVSS No. 108 or incorporated document citation	FMVSS No. 108 rewrite NPRM citation	FMVSS No. 108 rewrite final rule citation
S9.4.1.2 Manual override	S7.14.4.1.2 Manual override	SAE J565b, Feb 1969, 4.4.
S9.4.1.3 Fail safe operation	S7.14.4.1.3 Fail safe operation	SAE J565b, Feb 1969, 4.6.
S9.4.1.4 Automatic dimming indicator	S7.14.4.1.4 Automatic dimming indicator	SAE J565b, Feb 1969, 4.13.
S9.4.1.5 Lens accessibility	S7.14.4.1.5 Lens accessibility	SAE J565b, Feb 1969, 4.16.
S9.4.1.6 Mounting height	S7.14.4.1.6 Mounting height	SAE J565b, Feb 1969, 4.17.
S9.4.1.7 Physical tests	Table XXI	SAE J565b, Feb 1969.
S9.5 Upper beam headlamp indicator	S7.14.5 Upper beam headlamp indicator	S5.5.2 Upper beam indicator.
S9.5.1 Indicator size, location, and color	S7.14.5.1 Indicator size and location	S5.5.2; SAE J564a, Apr 1964.
S9.6 Vehicular hazard warning signal operating unit.	New title	New title.
S9.6.1 Combinations	S7.14.6 Vehicular hazard warning signal operating unit.	SAE J910, Jan 1966, 3(b) and (d).
S9.6.2 Operation	S7.14.6.1 Operating unit switch	S5.5.5; SAE J910, Jan 1966, 3(c) and (e).
S9.6.3 Physical tests	Table XXI	SAE J910, Jan 1966.
S9.7 Vehicular hazard warning signal flasher ..	New title	New title.
S9.7.1 Indicator signals	S7.14.7 Vehicular hazard warning signal flasher.	SAE J945, Feb 1966.
S9.7.2 Physical tests	Table XXI	SAE J945, Feb 1966.
S9.8 Vehicular hazard warning signal pilot indicator.	New title	New title.
S9.8.1 Two TS indicators	S7.14.8 Vehicular hazard warning signal pilot indicator.	New title.
S9.8.2 Single TS indicators	S7.14.8 Vehicular hazard warning signal pilot indicator.	SAE J910, Jan 1966, 5; SAE J945, Feb 1966.
S9.8.3 Function	S7.14.8 Vehicular hazard warning signal pilot indicator.	SAE J910, Jan 1966, 5; SAE J945, Feb 1966.
S9.8.4 Indicator size and color	S7.14.8.1 Indicator size and color	SAE J910, Jan 1966, 5; SAE J945, Feb 1966.
S10 Headlighting system requirements	S8 Headlighting system requirements	S7 Headlighting requirements.
S10.1 Vehicle headlighting systems	New title	New title.
S10.1.1 Vehicles ex motorcycles & trailers	S8.1 Headlighting systems	S7.1.
S10.1.2 Motorcycles	S8.1 Headlighting systems	S7.9.2(b).
S10.2 Aiming	S10.2 Aimability	S7.8.5.
S10.3 Number [New section—points to Table I]	New section	New section.
S10.4 Color of light [New section—points to Table I].	New section	New section.
S10.5 Mounting location [New section—points to Table I].	New section	New section.
S10.6 Mounting height [New section—points to Table I].	New section	New section.
S10.7 Activation [New section—points to Table I, Table II, and S6.1.5].	New section	New section.
S10.8 Effective projected luminous lens area [New section—No requirement].	New section	New section.
S10.9 Visibility [New section—No requirement]	New section	New section.
S10.10 Indicator [New section—points to S9.5]	New section	New section.
S10.11 Markings [New section—points to S6.5]	New section	New section.
S10.12 Spacing to other lamps [New section—points to S6.1.4.2].	New section	New section.
S10.13 Sealed beam headlighting system	S9 Sealed beam headlamp requirements	S7.3 Sealed beam headlighting system.
S10.13.1 Installation	S9.1 Installation	S7.3.2 Type A headlighting system.
S10.13.1 Installation	S9.1 Installation	S7.3.3 Type B headlighting system.
S10.13.1 Installation	S9.1 Installation	S7.3.4 Type C headlighting system.
S10.13.1 Installation	S9.1 Installation	S7.3.5 Type D headlighting system.
S10.13.1 Installation	S9.1 Installation	S7.3.6 Type E headlighting system.
S10.13.1 Installation	S9.1 Installation	S7.3.7 Type F headlighting system.
S10.13.1 Installation	S9.1 Installation	S7.3.8 Type G headlighting system.
S10.13.1 Installation	S9.1 Installation	S7.3.9 Type H headlighting system.
S10.13.2 Simultaneous aim	S9.2 Simultaneous aim	S7.3.7(h).
S10.13.2 Simultaneous aim	S9.2 Simultaneous aim	S7.3.7(h)(1).
S10.13.2 Simultaneous aim	S9.2 Simultaneous aim	S7.3.7(h)(2).
S10.13.3 Photometry	S9.3 Photometry	S7.3.2(a)(3).
S10.13.3 Photometry	S9.3 Photometry	S7.3.3(a).
S10.13.3 Photometry	S9.3 Photometry	S7.3.4.
S10.13.3 Photometry	S9.3 Photometry	S7.3.5(a).
S10.13.3 Photometry	S9.3 Photometry	S7.3.6(a).
S10.13.3 Photometry	S9.3 Photometry	S7.3.7(b).
S10.13.3 Photometry	S9.3 Photometry	S7.3.8(b).
S10.13.3 Photometry	S9.3 Photometry	S7.3.9(a).
S10.13.4 Physical tests	S9.4 Physical tests	New title.
S10.13.4.1 Aiming adjustment test	S9.4 Physical tests	SAE J580, Dec 1986, 4.2.
S10.13.4.1 Connector test	S9.4 Physical tests	SAE J580, Dec 1986, 4.4.

APPENDIX B.—FMVSS NO. 108 REWRITE CROSS REFERENCE—Continued

Current FMVSS No. 108 or incorporated document citation	FMVSS No. 108 rewrite NPRM citation	FMVSS No. 108 rewrite final rule citation
S10.13.4.1 Corrosion	S9.4 Physical tests	SAE J580, Dec 1986, 4.1.2.
S10.13.4.1 Inward force test	S9.4 Physical tests	SAE J580, Dec 1986, 4.3.
S10.13.4.1 Torque deflection test	S9.4 Physical tests	SAE J580, Dec 1986, 4.5.
S10.13.4.1 Vibration	S9.4 Physical tests	S7.3.2(c); S7.3.7(i); S7.3.8(d).
S10.13.4.1 Wattage	S9.4 Physical tests	S7.3.2(d); S7.3.3(b); S7.3.5(b); S7.3.6(b); S7.3.7(g); S7.3.8(e); S7.3.9(b).
S10.13.4.2 Retaining ring test ex types G & H	S9.4 Physical tests	S7.3.8(c) (1); SAE J580, Dec 1986, 5.1.6.
S10.13.4.3 Color test	S9.4 Physical tests	S5.1.5.
S10.13.4.3 Material test	S9.4 Physical tests	S5.1.2.
S10.14 Integral beam headlighting	S10 Integral beam headlamp requirements	S7.4 Integral Beam Headlighting System.
S10.14.1 Installation	S10.1 Installation	S7.4 Integral Beam Headlighting System.
S10.14.1 Installation	S10.1 Installation	S7.4(a).
S10.14.2 Aimability	S10.2 Aimability	S7.4(f).
S10.14.3 Simultaneous aim	S10.3 Simultaneous aim	S7.4(d).
S10.14.4 Markings	S10.4 Markings	S7.4(c)(1); S7.4(c)(2).
S10.14.5 Additional light sources	S10.5 Additional light sources	S7.4(i).
S10.14.6 Photometry	S10.6 Photometry	S7.4(a).
S10.14.7 Physical tests	S10.7 Physical tests	New title.
S10.14.7.1 Aiming adjustment tests	S10.7 Physical tests	SAE J580, Dec 1986, 4.2.
S10.14.7.1 Connector test	S10.7 Physical tests	SAE J580, Dec 1986, 4.4.
S10.14.7.1 Corrosion test	S10.7 Physical tests	S7.4(h)(3); S7.4(g).
S10.14.7.1 Inward force test	S10.7 Physical tests	S7.8.5.1(b); SAE J580, Dec 1986, 4.3.
S10.14.7.1 Temperature cycle test	S10.7 Physical tests	S7.4(h)(5)(i).
S10.14.7.1 Vibration test	S10.7 Physical tests	S7.4(h)(7).
S10.14.7.2 Connector—corrosion test	S10.7 Physical tests	S8.4(a); SAE J580, Dec 1986, 4.4.
S10.14.7.2 Dust test	S10.7 Physical tests	S7.4(h)(4); S7.4(g).
S10.14.7.2 Humidity test	S10.7 Physical tests	S7.4(h)(6); S7.4(g).
S10.14.7.2 Sealing test	S10.7 Physical tests	S7.4(g).
S10.14.7.3 Abrasion test	S10.7 Physical tests	S7.4(h)(1); S7.4(g).
S10.14.7.4 Chemical resistance test	S10.7 Physical tests	S7.4(h)(2); S7.4(g).
S10.14.7.5 Internal heat test	S10.7 Physical tests	S7.4(h)(5)(ii); S7.4(g).
S10.14.7.6 Chemical resistance—reflector	S10.7 Physical tests	S7.4(h)(2).
S10.14.7.6 Corrosion resistance—reflector	S10.7 Physical tests	S7.4(h)(3).
S10.14.7.7 Torque deflection test	S10.7 Physical tests	S7.8.5.1(a).
S10.14.7.8 Color test	S10.7 Physical tests	S5.1.5.
S10.14.7.8 Material test	S10.7 Physical tests	S5.1.2.
S10.15 Replaceable bulb headlighting system	S11 Replaceable bulb headlamp requirements	S7.5 Replaceable bulb headlighting system.
S10.15.1 Installation	S11.1 Installation	S7.5(a).
S10.15.2 Aiming restrictions	S11.2 Aiming restrictions	S7.5(d)(1).
S10.15.2 Aiming restrictions	S11.2 Aiming restrictions	S7.5(e)(1).
S10.15.2 Aiming restrictions	S11.2 Aiming restrictions	S7.5(h).
S10.15.3 Replacement equipment	S11.4 Replacement equipment	S7.5(f).
S10.15.4 Markings	S11.5 Markings	New title.
S10.15.4.1 U & L	S11.5 Markings	S7.5(d)(3)(i)(B).
S10.15.4.1 U & L	S11.5 Markings	S7.5(d)(3)(ii)(B).
S10.15.4.1 U & L	S11.5 Markings	S7.5(e)(3)(i).
S10.15.4.1 U & L	S11.5 Markings	S7.5(e)(3)(ii).
S10.15.4.1.1 Exception	Omitted	S7.5(d)(3)(i)(A).
S10.15.4.1.1 Exception	Omitted	S7.5(d)(3)(ii)(A).
S10.15.5. Additional light sources	S11.3 Additional light sources	S7.5(j).
S10.15.6 Photometry	S11.6 Photometry	S7.5(b).
S10.15.7 Physical tests	S11.7 Physical tests	S7.5(i).
S10.15.7.1 Aiming adjustment tests	S11.7 Physical tests	SAE J580, Dec 1986, 4.2.
S10.15.7.1 Connector test	S11.7 Physical tests	SAE J580, Dec 1986, 4.4.
S10.15.7.1 Corrosion test	S11.7 Physical tests	S7.4(h)(3); S7.4(g).
S10.15.7.1 Corrosion—connector test	S11.7 Physical tests	S8.4(a); SAE J580, Dec 1986, 4.4.
S10.15.7.1 Dust test	S11.7 Physical tests	S7.4(h)(4); S7.4(g).
S10.15.7.1 Humidity test	S11.7 Physical tests	S7.4(h)(6); S7.4(g).
S10.15.7.1 Inward force test	S11.7 Physical tests	S7.8.5.1(b); SAE J580, Dec 1986, 4.3.
S10.15.7.1 Temperature cycle test	S11.7 Physical tests	S7.4(h)(5)(i).
S10.15.7.1 Vibration test	S11.7 Physical tests	S7.4(h)(7).
S10.15.7.2 Abrasion test	S11.7 Physical tests	S7.4(h)(1); S7.4(g).
S10.15.7.3 Chemical resistance test	S11.7 Physical tests	S7.4(h)(2); S7.4(g).
S10.15.7.4 Internal heat test	S11.7 Physical tests	S7.4(h)(5)(ii); S7.4(g).
S10.15.7.5 Chemical resistance—reflector	S11.7 Physical tests	S7.4(h)(2).
S10.15.7.5 Corrosion resistance—reflector	S11.7 Physical tests	S7.4(h)(3).
S10.15.7.6 Torque deflection test	S11.7 Physical tests	S7.8.5.1(a).
S10.15.7.7 Color test	S11.7 Physical tests	S5.1.5.
S10.15.7.7 Material test	S11.7 Physical tests	S5.1.2.
S10.16 Combination headlighting system	S12 Combination headlamps	S7.6 Combination Headlighting System.
S10.16.1 Installation	S12.1 Installation	S7.6.1.

APPENDIX B.—FMVSS NO. 108 REWRITE CROSS REFERENCE—Continued

Current FMVSS No. 108 or incorporated document citation	FMVSS No. 108 rewrite NPRM citation	FMVSS No. 108 rewrite final rule citation
S10.16.2 Photometry	S12.2 Photometry	S7.6.2.
S10.16.2 Photometry	S12.2 Photometry	S7.6.2.1.
S10.16.2 Photometry	S12.2 Photometry	S7.6.2.2.
S10.16.2 Photometry	S12.2 Photometry	S7.6.3.
S10.16.3 Physical tests	S12.3 Physical tests	New title.
S10.16.3.1 Type F sealed beam	S12.3 Physical tests	S7.6.2.
S10.16.3.2 Integral beam	S12.3 Physical tests	S7.6.2.1.
S10.16.3.3 Replaceable bulb	S12.3 Physical tests	S7.6.2.2.
S10.17 Motorcycle headlighting system	S13 Motorcycle headlamp requirements	S7.9.2.
S10.17.1 Installation	S13.1 Installation	S7.9.6.1.
S10.17.1.1 Single headlamp	S13.1.1 Single headlamp	S7.9.6.2(a).
S10.17.1.2 Two headlamps with both beams ...	S13.1.2 Two headlamps with both beams	S7.9.6.2(b).
S10.17.1.3 Two headlamps, upper beam and lower beam.	S13.1.3 Two headlamps, upper beam and lower beam.	S7.9.6.2(c).
S10.17.2 Motorcycle replaceable bulb headlamp marking.	S13.4 Motorcycle replaceable bulb headlamp marking.	S7.9.5.
S10.17.3 Photometry	S13.2 Photometry	S7.9.2(a).
S10.17.4 Physical tests	S13.3 Physical tests	SAE J584, Apr 1964.
S10.17.5 Motorcycle headlamp modulation system.	S13.5 Motorcycle headlamp modulation system.	S7.9.4.1.
S10.17.5.1(a) Rate	S13.5.1(a) Rate	S7.9.4.1(a).
S10.17.5.1(b) Maximum power	S13.5.1(b) Maximum power	S7.9.4.1(b).
S10.17.5.1(c) Minimum intensity	S13.5.1(c) Minimum intensity	S7.9.4.1(c).
S10.17.5.1(d) Wiring	S13.5.1(d) Wiring	S7.9.4.1(d).
S10.17.5.1(e) Failure mode	S13.5.1(e) Failure mode	S7.9.4.1(e).
S10.17.5.1(f) Sensor	S13.5.1(f) Sensor	S7.9.4.1(f).
S10.17.5.1(g) Voltage drop	S13.5.1(g) Voltage drop	S7.9.4.1(g).
S10.17.5.1(h) Full voltage operation	S13.5.1(h) Full voltage operation	S7.9.4.1(h).
S10.17.5.2 Replacement modulators	S13.5.2 Replacement modulators	S7.9.4.2(a).
S10.17.5.2.1 Replacement performance	S13.5.2.1 Replacement performance	S7.9.4.2(a).
S10.17.5.2.2 Replacement instructions	S13.5.2.2 Replacement instructions	S7.9.4.2(b).
S10.18.1 Headlamp mounting and aiming	S14.1 Headlamp mounting and aiming	S7.8.2.
S10.18.1.1 Adjustments	S8.1.5 Headlamp adjustments	SAE J566, Jan 1960, 1.
S10.18.1.2 Procedure & security	S8.1.5 Headlamp adjustments	SAE J566, Jan 1960, 2.
S10.18.1.2 Procedure & security	S8.1.5 Headlamp adjustments	SAE J566, Jan 1960, 3.
S10.18.2 Headlamp aiming systems	S14.3 Headlamp aiming systems	S7.8.5.
S10.18.3 Aim adjustment interaction	S14.4 Aim adjustment interaction	S7.8.2.1(a).
S10.18.3 Aim adjustment interaction	S14.4 Aim adjustment interaction	S7.8.2.1(b).
S10.18.3.1 Excess aim interaction	S14.4.1 Excess aim interaction	S7.8.5.2(b)(3).
S10.18.4 Horizontal adjustment—visually aimed headlamp.	S14.5 Horizontal adjustment—visually aimed headlamp.	S7.8.2.1(c).
S10.18.5 Optical axis marking	S14.6 Optical axis marking	S7.8.1.
S10.18.5.1 Optical axis marking—vehicle	S14.6.1 Optical axis marking—vehicle	S7.8.1(b).
S10.18.5.2 Optical axis marking—lamp	S14.6.2 Optical axis marking—lamp	S7.8.1(a).
S10.18.5.3 Optical axis marking—visual aim headlamp.	S14.6.3 Optical axis marking—visual aim headlamp.	S7.8.1(c).
S10.18.5.3 Optical axis marking—visual aim headlamp.	S14.6.3 Optical axis marking—visual aim headlamp.	S7.8.5.3(f)(1).
S10.18.6 Moveable reflector requirements	S14.7 Moveable reflectors	S7.8.2.2(a).
S10.18.6 Moveable reflector requirements	S14.7 Moveable reflectors	S7.8.2.2(b).
S10.18.7 External aiming	S14.8 External aiming	S7.8.5.1 External aiming.
S10.18.7.1 Headlamp aiming device locating plates.	S14.8.1 Headlamp aiming device locating plates.	S7.8.5.1(d).
S10.18.7.1.1 Aiming pads	S14.8.1.1 Aiming pads	S7.8.5.1(d)(1).
S10.18.7.1.2 Aiming dimension marking	S14.8.1.2 Aiming dimension marking	S7.8.5.1(d)(2).
S10.18.7.2 Nonadjustable headlamp aiming device locating plates.	S14.8.2 Nonadjustable headlamp aiming device locating plates.	S7.8.5.1(e).
S10.18.8 On—vehicle aiming	S14.9 On—vehicle aiming	S7.8.5.2 On—vehicle aiming.
S10.18.8.1 Aim	S14.9.1 Aim	S7.8.5.2(a) Aim.
S10.18.8.1.1 Vertical aim	S14.9.1.1 Vertical aim	S7.8.5.2(a)(1) Vertical axis.
S10.18.8.1.1.1 Graduations	S14.9.1.1.1 Graduations	S7.8.5.2(a)(1)(i).
S10.18.8.1.1.2 VHAD markings	S14.9.1.1.2 VHAD markings	S7.8.5.2(a)(1)(ii).
S10.18.8.1.1.3 Graduation scale	S14.9.1.1.3 Graduation scale	S7.8.5.2(a)(1)(iii).
S10.18.8.1.1.4 Vertical indicator range	S14.9.1.1.4 Vertical indicator range	S7.8.5.2(a)(1)(iv).
S10.18.8.1.1.5 Floor slope compensation	S14.9.1.1.5 Floor slope compensation	S7.8.5.2(a)(1)(v).
S10.18.8.1.1.6 Graduation legibility	S14.9.1.1.6 Graduation legibility	S7.8.5.2(a)(1)(vi).
S10.18.8.1.2 Horizontal aim	S14.9.1.2 Horizontal aim	S7.8.5.2(a)(2) Horizontal aim.
S10.18.8.1.2.1 Graduation scale	S14.9.1.2.1 Graduation scale	S7.8.5.2(a)(2)(i).
S10.18.8.1.2.2 Horizontal markings	S14.9.1.2.2 Horizontal markings	S7.8.5.2(a)(2)(ii).
S10.18.8.1.2.3 Graduation legibility	S14.9.1.2.3 Graduation legibility	S7.8.5.2(a)(2)(iii).
S10.18.8.1.2.4 Horizontal indicator range	S14.9.1.2.4 Horizontal indicator range	S7.8.5.2(a)(2)(iv).

APPENDIX B.—FMVSS NO. 108 REWRITE CROSS REFERENCE—Continued

Current FMVSS No. 108 or incorporated document citation	FMVSS No. 108 rewrite NPRM citation	FMVSS No. 108 rewrite final rule citation
S10.18.8.2 Aiming instructions	S14.9.2 Aiming instructions	S7.8.5.2(b) Aiming instructions.
S10.18.8.2.1 Aiming instruction location and content.	S14.9.2.1 Aiming instruction location and content.	S7.8.5.2(b)(1).
S10.18.8.2.2 Remote indicator instructions	S14.9.2.2 Remote indicator instructions	S7.8.5.2(b)(2).
S10.18.8.3 Permanent calibration	S14.9.3 Permanent calibrations	S7.8.5.2(c).
S10.18.8.4 Replacement units	S14.9.4 Replacement units	S7.8.5.2(d)(2).
S10.18.8.5 Physical tests	S14.9.5 Physical tests	S7.8.5.2(d) Testing the VHAD.
S10.18.9 Visual/optical aiming	S14.10 Visual/optical aiming	S7.8.5.3 Visual/optical aiming.
S10.18.9.1 Vertical aim, lower beam	S14.10.1 Vertical aim, lower beam	S7.8.5.3(a) Vertical aim, lower beam.
S10.18.9.1.1 Vertical position of the cutoff	S14.10.1.1 Vertical position of the cutoff	S7.8.5.3(a)(1) Vertical position of cutoff.
S10.18.9.1.2 Vertical gradient	S14.10.1.2 Vertical gradient	S7.8.5.3(a)(2) Vertical gradient.
S10.18.9.1.3 Horizontal position of the cutoff ...	S14.10.1.3 Horizontal position of the cutoff	S7.8.5.3(a)(3) Horizontal position of the cutoff.
S10.18.9.1.4 Maximum inclination of the cutoff ..	S14.10.1.4 Maximum inclination of the cutoff ...	S7.8.5.3(a)(4) Maximum inclination of cutoff.
S10.18.9.1.5 Measuring the cutoff parameter ...	S14.10.1.5 Measuring the cutoff parameter ...	Interpretation—Spingler 4/6/2000.
S10.18.9.1.5 Measuring the cutoff parameter ...	S14.10.1.5 Measuring the cutoff parameter	S7.8.5.3(a)(5)(i).
S10.18.9.1.5.1 Test position	S14.10.1.5.1 Test position	S7.8.5.3(a)(5)(i).
S10.18.9.1.5.2 Headlamp aiming	S14.10.1.5.2 Headlamp aiming	S7.8.5.3(a)(5)(ii).
S10.18.9.1.5.3 Beam scanning	S14.10.1.5.3 Beam scanning	S7.8.5.3(a)(5)(iii).
S10.18.9.1.5.4 Gradient calculation	S14.10.1.5.4 Gradient calculation	S7.8.5.3(a)(5)(iv).
S10.18.9.2 Horizontal aim, lower beam	S14.10.2 Horizontal aim, lower beam	S7.8.5.3(b) Horizontal aim, lower beam.
S10.18.9.3 Vertical aim, upper beam	S14.10.3 Vertical aim, upper beam	S7.8.5.3(c) Vertical aim, upper beam.
S10.18.9.3.1 Combined upper and lower beams.	S14.10.3.1 Combined upper and lower beams	S7.8.5.3(c)(1).
S10.18.9.3.2 Upper beam without lower beam	S14.10.3.2 Upper beam without lower beam ..	S7.8.5.3(c)(2).
S10.18.9.4 Horizontal aim, upper beam	S14.10.4 Horizontal aim, upper beam	S7.8.5.3(d) Horizontal aim, upper beam.
S10.18.9.4.1 Combined upper and lower beams.	S14.10.4.1 Combined upper and lower beams	S7.8.5.3(d)(1).
S10.18.9.4.2 Upper beam without lower beam	S14.10.4.2 Upper beam without lower beam ..	S7.8.5.3(d)(2).
S10.18.9.4.3 Upper beam without lower beam of VHAD.	S14.10.4.3 Upper beam without lower beam of VHAD.	S7.8.5.3(d)(3).
S10.18.9.5 Photometry	S14.10.5 Photometric measurements	S7.8.5.3(e)(1).
S10.18.9.6 Visual/optical identification marking	S14.10.6 Visual/optical identification marking	S7.8.5.3(f)(2)(v).
S10.18.9.6.1 VOL/VOR/VO markings	S14.10.6.1 VOL/VOR/VO markings	S7.8.5.3(f)(2)(i).
S10.18.9.6.1 VOL/VOR/VO markings	S14.10.6.1 VOL/VOR/VO markings	S7.8.5.3(f)(2)(ii).
S10.18.9.6.1 VOL/VOR/VO markings	S14.10.6.1 VOL/VOR/VO markings	S7.8.5.3(f)(2)(iv).
S10.18.9.6.2 VOR/VO markings on sealed beams.	S14.10.6.2 VOR/VO markings on sealed beams.	S7.8.5.3(f)(2)(iii).
S11 Replaceable light sources	S15 Replaceable light sources	S7.7 Replaceable light sources.
S11.1 Markings	S15.1 Markings	S7.7(a).
S11.2 Ballast markings	S15.4 Ballast markings	S7.7(e).
S11.3 Gas discharge laboratory life	S15.5 Gas discharge laboratory life	S7.7(f).
S11.4 Physical tests	New title	New title.
S11.4.1 Deflection test	S15.6 Physical tests	S7.7(g).
S11.4.1 Pressure test	S15.6 Physical tests	S7.7(c).
S11.4.2 Power & Luminous flux tests	S15.2 Power and flux measurement	S7.7(b).
S11.4.2 Power & Luminous flux tests	S15.3 Power and flux measurement	S7.7(d).
S12 Headlamp concealment device requirements.	S16 Headlamp concealment device requirements.	S12 Headlamp concealment devices.
S12.1 Power loss during headlamp use	S16.1 Power loss during headlamp use	S12.1.
S12.2 Manual device actuation	S16.2 Manual device actuation	S12.2.
S12.3 Single step actuation	S16.3 Single step actuation	S12.3.
S12.4 Headlamp aiming and replacement	S16.4 Headlamp aiming and replacement	S12.4.
S12.5 Operational temperature range and time limitation.	S16.5 Operational temperature range and time limitation.	S12.5.
S12.6 ECE compliance alternative	S16.6 ECE compliance alternative	S12.6.
S12.7 Certification election	S16.7 Certification election	S12.7 Certification election.
S13 Replaceable headlamp lens requirements	S18 Replaceable headlamp lens requirements	S5.8.1.
S13 Replaceable headlamp lens requirements	S18 Replaceable headlamp lens requirements	S5.8.11.
S13 Replaceable headlamp lens requirements	S18 Replaceable headlamp lens requirements	S7.2(e).
S14 Physical and photometry test procedures and performance requirements.	New title	New title.
S14.1 General test procedures and performance requirements.	New title	New title.
S14.1.1 Physical test requirements	S6.8.1 Physical test requirements	SAE device documents referencing SAE J575.
S14.1.2 Plastic optical materials	S6.8.4 Plastic optical materials	S5.1.2.
S14.1.3 UV tracer	S6.8.4.1 UV tracer	SAE J576, Jul 1991, 5.
S14.1.4.1 Representative samples	S6.8.2 Samples for test	SAE J1383, Apr 1985, 4.5.1.
S14.1.4.2 Mounting bracket	S6.8.2 Samples for test	SAE J575, Dec 1988, 2.1.
S14.1.4.2 Mounting bracket	S6.8.2 Samples for test	SAE J575, Dec 1988, 2.3.
S14.1.4.3 Second sample set	S6.8.2 Samples for test	SAE J575d, Aug 1967, B.

APPENDIX B.—FMVSS NO. 108 REWRITE CROSS REFERENCE—Continued

Current FMVSS No. 108 or incorporated document citation	FMVSS No. 108 rewrite NPRM citation	FMVSS No. 108 rewrite final rule citation
S14.1.4.3 Second sample set	S6.8.2 Samples for test	SAE J575e, Aug 1970, B.
S14.1.5 Laboratory facilities	S6.8.3 Laboratory facilities	SAE J575, Dec 1988, 3.
S14.1.5 Laboratory facilities	S6.8.3 Laboratory facilities	SAE J575d, Aug 1967, D.
S14.1.5 Laboratory facilities	S6.8.3 Laboratory facilities	SAE J575e, Aug 1970, D.
S14.2 Photometric test procedures	S6.8.5 Photometric tests	S5.7.1.2.
S14.2 Photometric test procedures	S6.8.5 Photometric tests	S5.7.2.1(a).
S14.2 Photometric test procedures	S6.8.5 Photometric tests	S7.3.2(a)(3).
S14.2 Photometric test procedures	S6.8.5 Photometric tests	S7.3.3(a).
S14.2 Photometric test procedures	S6.8.5 Photometric tests	S7.3.4 Type C headlighting system.
S14.2 Photometric test procedures	S6.8.5 Photometric tests	S7.3.5(a).
S14.2 Photometric test procedures	S6.8.5 Photometric tests	S7.3.6(a).
S14.2 Photometric test procedures	S6.8.5 Photometric tests	S7.3.7(b).
S14.2 Photometric test procedures	S6.8.5 Photometric tests	S7.3.7(d).
S14.2 Photometric test procedures	S6.8.5 Photometric tests	S7.3.7(h)(1).
S14.2 Photometric test procedures	S6.8.5 Photometric tests	S7.3.8(b).
S14.2 Photometric test procedures	S6.8.5 Photometric tests	S7.3.9(a).
S14.2 Photometric test procedures	S6.8.5 Photometric tests	S7.4(a)(1)(i).
S14.2 Photometric test procedures	S6.8.5 Photometric tests	S7.4(a)(1)(ii).
S14.2 Photometric test procedures	S6.8.5 Photometric tests	S7.4(a)(1)(iii).
S14.2 Photometric test procedures	S6.8.5 Photometric tests	S7.4(a)(2)(i).
S14.2 Photometric test procedures	S6.8.5 Photometric tests	S7.4(a)(2)(ii).
S14.2 Photometric test procedures	S6.8.5 Photometric tests	S7.4(a)(3).
S14.2 Photometric test procedures	S6.8.5 Photometric tests	S7.5(b).
S14.2 Photometric test procedures	S6.8.5 Photometric tests	S7.5(d)(2).
S14.2 Photometric test procedures	S6.8.5 Photometric tests	S7.5(e)(2).
S14.2 Photometric test procedures	S6.8.5 Photometric tests	S7.6.2.
S14.2 Photometric test procedures	S6.8.5 Photometric tests	S7.6.3.
S14.2 Photometric test procedures	S6.8.5 Photometric tests	S7.9.2.
S14.2 Photometric test procedures	S6.8.5 Photometric tests	SAE device documents referencing SAE J575.
S14.2.1 Photometry measurements for all lamps except license lamps, headlamps, and DRLs.	S6.8.5.1 Photometry ex headlamp, license lamp, & DRL.	New title.
S14.2.1.1 Mounting	S6.8.5.1 Photometry ex headlamp, license lamp, & DRL.	SAE J575d, Aug 1967, J; SAE J575e, Aug 1970, J.
S14.2.1.2 School bus signal lamp aiming	S6.8.5.1 Photometry ex headlamp, license lamp, & DRL.	SAE J887, Jul 1964.
S14.2.1.3 Measurement distance	S6.8.5.1 Photometry ex headlamp, license lamp, & DRL.	SAE device documents for photometry distance.
S14.2.1.4 Location of test points	S6.8.5.1.1 Location of test points	SAE J575d, Aug 1967, J; SAE J575e, Aug 1970, J.
S14.2.1.5 Multiple compartment and multiple lamp photometry of turn signal lamps, stop lamps, and taillamps.	S6.8.5.1.2 Multiple compartment & multiple lamp photometry.	New title.
S14.2.1.5.1 All photometered together	S6.8.5.1.2 Multiple compartment & multiple lamp photometry.	SAE J1395, Apr 1985, 4.1.5.2.
S14.2.1.5.1 All photometered together	S6.8.5.1.2 Multiple compartment & multiple lamp photometry.	SAE J1398, May 1985, 4.1.5.2.
S14.2.1.5.1 All photometered together	S6.8.5.1.2 Multiple compartment & multiple lamp photometry.	SAE J585e, Sep 1977, 3.6.2.
S14.2.1.5.1 All photometered together	S6.8.5.1.2 Multiple compartment & multiple lamp photometry.	SAE J586, Feb 1984, 4.1.5.2.
S14.2.1.5.1 All photometered together	S6.8.5.1.2 Multiple compartment & multiple lamp photometry.	SAE J588, Nov 1984, 4.1.5.2.
S14.2.1.5.2(a) Measuring together	S6.8.5.1.2.1 Photometry of all compartments/lamps together.	SAE J585e, Sep 1977, 3.6.2(a).
S14.2.1.5.2(a) Measuring together	S6.8.5.1.2.1 Photometry of all compartments/lamps together.	SAE J586, Feb 1984, 4.1.5.2.1.
S14.2.1.5.2(a) Measuring together	S6.8.5.1.2.1 Photometry of all compartments/lamps together.	SAE J588, Nov 1984, 4.1.5.2.1.
S14.2.1.5.2(b) Measuring individually	S6.8.5.1.2.2 Photometry of individual compartments/lamps.	SAE J1395, Apr 1985, 4.1.5.2.
S14.2.1.5.2(b) Measuring individually	S6.8.5.1.2.2 Photometry of individual compartments/lamps.	SAE J1398, May 1985, 4.1.5.2.
S14.2.1.5.2(b) Measuring individually	S6.8.5.1.2.2 Photometry of individual compartments/lamps.	SAE J585e, Sep 1977, 3.6.2(b).
S14.2.1.5.2(b) Measuring individually	S6.8.5.1.2.2 Photometry of individual compartments/lamps.	SAE J586, Feb 1984, 4.1.5.2.2.
S14.2.1.5.2(b) Measuring individually	S6.8.5.1.2.2 Photometry of individual compartments/lamps.	SAE J588, Nov 1984, 4.1.5.2.2.

APPENDIX B.—FMVSS NO. 108 REWRITE CROSS REFERENCE—Continued

Current FMVSS No. 108 or incorporated document citation	FMVSS No. 108 rewrite NPRM citation	FMVSS No. 108 rewrite final rule citation
S14.2.1.5.3 Multiple on 2032 mm or wider	S6.8.5.1.2.3 Multiple compartment/lamp photometry for wide vehicles.	SAE J1395, Apr 1985, 4.1.5.2.
S14.2.1.5.3 Multiple on 2032 mm or wider	S6.8.5.1.2.3 Multiple compartment/lamp photometry for wide vehicles.	SAE J1398, May 1985, 4.1.5.2.
S14.2.1.6 Bulbs	S6.8.5.2 Bulbs	S5.1.1.17.
S14.2.1.6.1 Bulbs without MSCD	S6.8.5.2.1 Bulbs without MSCD	S5.1.1.16.
S14.2.1.6.2 Socket exemption	Omitted	Table IV footnotes 2 and 3.
S14.2.2 License plate lamp photometry	S6.8.5.3 License plate lamp photometry	SAE J587, Oct 1981, 6.3.
S14.2.2.1 Illumination surface	S6.8.5.3.1 Illumination surface	SAE J587, Oct 1981, 6.7.
S14.2.2.2 Test stations	S6.8.5.3.2 Test stations	SAE J587, Oct 1981, 6.8.
S14.2.2.3 Bulbs	S6.8.5.2 Bulbs	S5.1.1.17.
S14.2.3 Reflex reflector and retroreflective sheeting photometry.	S6.8.5.4 Reflex reflector photometry	SAE J594f, Jan 1977, 3.1.7.
S14.2.3.1 Mounting	S6.8.5.4 Reflex reflector photometry	SAE J594f, Jan 1977, 3.1.7.
S14.2.3.2 Illumination source	S6.8.5.4 Reflex reflector photometry	SAE J594f, Jan 1977, 3.1.7.
S14.2.3.3 Measurement distance	S6.8.5.4 Reflex reflector photometry	SAE J594f, Jan 1977, 3.1.7.
S14.2.3.4 Test setup	S6.8.5.4 Reflex reflector photometry	SAE J594f, Jan 1977, 3.1.7.
S14.2.3.5 Photodetector	S6.8.5.4 Reflex reflector photometry	SAE J594f, Jan 1977, 3.1.7.
S14.2.3.6 Photometry surface	S6.8.5.4 Reflex reflector photometry	SAE J594f, Jan 1977, 3.1.7.
S14.2.3.7 Procedure	S6.8.5.4.1 Reflex reflector and retroreflective sheeting photometry measurements.	SAE J594f, Jan 1977, 3.1.7.
S14.2.3.7.1 Observation angel	S6.8.5.4.1 Reflex reflector and retroreflective sheeting photometry measurements.	SAE J594f, Jan 1977, 3.1.7.
S14.2.3.7.2 Entrance angle	S6.8.5.4.1 Reflex reflector and retroreflective sheeting photometry measurements.	SAE J594f, Jan 1977, 3.1.7.
S14.2.3.7.3 Convention	S6.8.5.4.1 Reflex reflector and retroreflective sheeting photometry measurements.	SAE J594f, Jan 1977, 3.1.7.
S14.2.3.7.4 Luminous intensity and illumination	S6.8.5.4.1 Reflex reflector and retroreflective sheeting photometry measurements.	SAE J594f, Jan 1977, 3.1.7.
S14.2.3.8 Measurements	S6.8.5.4.1 Reflex reflector and retroreflective sheeting photometry measurements.	SAE J594f, Jan 1977, 3.1.7.
S14.2.3.8.1 Reflex reflectors	S6.8.5.4.1 Reflex reflector and retroreflective sheeting photometry measurements.	S5.7.2 Reflex reflectors.
S14.2.3.8.2 Retroreflective sheeting	S6.8.5.4.1 Reflex reflector and retroreflective sheeting photometry measurements.	S5.7.1.2 Performance requirements.
S14.2.3.8.3 Reflex reflector photometry measurement adjustments.	S6.8.5.4.1.1 Reflex reflector photometry measurement adjustments.	SAE J594f, Jan 1977, 3.1.7.
S14.2.3.8.3.1 Reflectors with non fixed rotation	S6.8.5.4.1.1 Reflex reflector photometry measurement adjustments.	SAE J594f, Jan 1977, 3.1.7.
S14.2.3.8.3.2 Reflectors with fixed rotation	S6.8.5.4.1.1 Reflex reflector photometry measurement adjustments.	SAE J594f, Jan 1977, 3.1.7.
S14.2.3.8.3.3 Additional photometric readings ..	S6.8.5.4.1.1 Reflex reflector photometry measurement adjustments.	SAE J594f, Jan 1977, 3.1.7.
S14.2.4 Daytime running lamp (DRL) photometry measurements.	S6.8.5.5 Daytime running lamp (DRL) photometry measurements.	New title.
S14.2.4.1	S6.8.5.5 Daytime running lamp (DRL) photometry measurements.	S11 Photometric Test.
S14.2.4.2	S6.8.5.5 Daytime running lamp (DRL) photometry measurements.	S11 Photometric Test.
S14.2.4.3 Bulbs	S6.8.5.2 Bulbs	S5.1.1.17.
S14.2.5 Headlamp photometry measurements	S6.8.5.6 Headlamp photometry measurements.	New title.
S14.2.5.1 Mounting	S6.8.5.6 Headlamp photometry measurements.	SAE J575, Dec 1988, 4.6.3.
S14.2.5.2 Glare area	S6.8.5.6.5 Location of test points	S7.2(d).
S14.2.5.3 Measurement distance	S6.8.5.6 Headlamp photometry measurements.	S10(a).
S14.2.5.3 Measurement distance	S6.8.5.6 Headlamp photometry measurements.	S10(b).
S14.2.5.3 Measurement distance	S6.8.5.6 Headlamp photometry measurements.	S7.4(e).
S14.2.5.3 Measurement distance	S6.8.5.6 Headlamp photometry measurements.	S7.5(c).
S14.2.5.3 Measurement distance	S6.8.5.6 Headlamp photometry measurements.	S7.8.5.2(d)(1).
S14.2.5.3 Measurement distance	S6.8.5.6 Headlamp photometry measurements.	SAE J1383, Apr 1985, 4.1.4.2.
S14.2.5.4 Seasoning and test voltage	S6.8.5.6.1 Seasoning and test voltage	SAE J1383, Apr 1985, 4.1.4.1.
S14.2.5.4 Seasoning and test voltage	S6.8.5.6.1 Seasoning and test voltage	SAE J1383, Apr 1985, 4.1.4.3.
S14.2.5.4 Seasoning and test voltage	S6.8.5.6.1 Seasoning and test voltage	SAE J575, Dec 1988, 4.6.3.4.
S14.2.5.5 Aiming	S6.8.5.6.2 Aiming	S7.2(d).

APPENDIX B.—FMVSS NO. 108 REWRITE CROSS REFERENCE—Continued

Current FMVSS No. 108 or incorporated document citation	FMVSS No. 108 rewrite NPRM citation	FMVSS No. 108 rewrite final rule citation
S14.2.5.5 Aiming	S6.8.5.6.2 Aiming	S7.3.7(b).
S14.2.5.5 Aiming	S6.8.5.6.2 Aiming	S7.8.5.2(d)(1).
S14.2.5.5 Aiming	S6.8.5.6.2 Aiming	S7.8.5.3(e)(2).
S14.2.5.5.1 Mechanically aimable headlamps using an external aimer.	S6.8.5.6.2(a) Aiming—mechanical	SAE J1383, Apr 1985, 4.1.4.3.
S14.2.5.5.2 Mechanically aimable headlamps equipped with a VHAD.	S6.8.5.6.2(b) Aiming—VHAD	S7.8.5.2(d)(1).
S14.2.5.5.3 Visually aimable lower beam headlamps—vertical aim.	S6.8.5.6.2(c) Aiming—LB VOL/VOR vertical ...	New title.
S14.2.5.5.3.1 VOL	S6.8.5.6.2(c) Aiming—LB VOL/VOR vertical ...	S7.8.5.3(a)(1) and (e)(2).
S14.2.5.5.3.2 VOR	S6.8.5.6.2(c) Aiming—LB VOL/VOR vertical ...	S7.8.5.3(a)(1) and (e)(2).
S14.2.5.5.4 Visually aimable lower beam headlamps—horizontal aim.	S6.8.5.6.2(d) Aiming—LB VOL/VOR horizontal	S7.8.5.3(b) Horizontal aim, lower beam.
S14.2.5.5.5 Visually aimable upper beam headlamps—vertical aim.	S6.8.5.6.2(e) Aiming—UB VOL/VOR vertical ..	New title.
S14.2.5.5.5.1 Combined UB & LB	S6.8.5.6.2(e) Aiming—UB VOL/VOR vertical ..	S7.8.5.3(c)(1) and (e)(2).
S14.2.5.5.5.2 Non—combined UB & LB	S6.8.5.6.2(e) Aiming—UB VOL/VOR vertical ..	S7.8.5.3(c)(2) and (e)(2).
S14.2.5.5.6 Visually aimable upper beam headlamps—horizontal aim.	S6.8.5.6.2(f) Aiming—UB VOL/VOR horizontal	New title.
S14.2.5.5.6.1 Combined UB & LB	S6.8.5.6.2(f) Aiming—UB VOL/VOR horizontal	S7.8.5.3(d)(1).
S14.2.5.5.6.2 Non-combined UB & LB with VHAD.	S6.8.5.6.2(f) Aiming—UB VOL/VOR horizontal	S7.8.5.3(d)(2).
S14.2.5.5.6.3 Non-combined UB & LB without VHAD.	S6.8.5.6.2(f) Aiming—UB VOL/VOR horizontal	S7.8.5.3(d)(3).
S14.2.5.5.7 Simultaneous aim Type F sealed beam headlamps and beam contributor integral beam headlamps.	S6.8.5.6.2(g) Aiming—Simultaneous aim	S10(a) and (b).
S14.2.5.5.8 Motorcycle headlamp—upper beam headlamps designed to comply with Table XX.	S6.8.5.6.2(i) Aiming—Motorcycle UB	S7.9.3 and SAE J584, Oct 1993.
S14.2.5.5.9 Motorcycle headlamp—lower beam headlamps designed to comply with Table XX.	S6.8.5.6.2(j) Aiming—Motorcycle LB	SAE J584, Apr 1964.
S14.2.5.6 Positioner	S6.8.5.6.3 Positioner	SAE J575, Dec 1988, 4.6.2.1.
S14.2.5.7 Photometer	S6.8.5.6.4 Photometer	New title.
S14.2.5.7.1 Range	S6.8.5.6.4 Photometer	SAE J575, Dec 1988, 4.6.2.2.
S14.2.5.7.2 Sensor	S6.8.5.6.4 Photometer	SAE J575, Dec 1988, 4.6.2.3.
S14.2.5.7.2.1 Effective area	S6.8.5.6.4 Photometer	SAE J575, Dec 1988, 4.6.2.3.1.
S14.2.5.7.2.2 Intercepted light	S6.8.5.6.4 Photometer	SAE J575, Dec 1988, 4.6.2.3.1.
S14.2.5.7.2.3 Direct illumination	S6.8.5.6.4 Photometer	SAE J575, Dec 1988, 4.6.2.3.1.
S14.2.5.7.3 Color response	S6.8.5.6.4 Photometer	SAE J575, Dec 1988, 4.6.2.3.2.
S14.2.5.8 Location of test points	S6.8.5.6.5 Location of test points	SAE J575, Dec 1988, 4.6.3.3.
S14.2.5.8.1 Nomenclature	S6.8.5.6.5 Location of test points	SAE J575, Dec 1988, 4.6.3.3.
S14.2.5.8.1.1 “H—V”	S6.8.5.6.5 Location of test points	SAE J575, Dec 1988, 4.6.3.3.
S14.2.5.8.1.2 “U” “D” “L” “R”	S6.8.5.6.5 Location of test points	SAE J575, Dec 1988, 4.6.3.3.
S14.2.5.8.1.3 Angles	S6.8.5.6.5 Location of test points	SAE J575, Dec 1988, 4.6.3.3.
S14.2.5.9 Beam contributor photometry measurements.	S6.8.5.6.6 Beam contributor photometry	S7.4(a)(3).
S14.2.5.10 Moveable reflector aimed headlamp photometry measurements.	S6.8.5.6.2(h) Aiming—Moveable reflector	New title.
S14.2.5.10.1	S6.8.5.6.2(h) Aiming—Moveable reflector	S7.8.2.2(b).
S14.2.5.10.2	S6.8.5.6.2(h) Aiming—Moveable reflector	S7.8.3.
S14.2.5.10.3	S6.8.5.6.2(h) Aiming—Moveable reflector	S7.8.4.
S14.3 Out of focus test	Table XXII Out of focus test	SAE J575d, Aug 1967, K.
S14.3.1 Procedure	Table XXII Out of focus test—procedure	SAE J575d, Aug 1967, K.
S14.3.2 Performance requirements	Table XXII Out of focus test—performance requirements.	SAE J575d, Aug 1967, K.
S14.4 General test procedures and performance requirements.	New title	New title.
S14.4.1 Color test	Table XXII Color test	SAE J578c, Feb 1977.
S14.4.1.1 Samples	S6.8.2 Samples for test	SAE J594f, Jan 1977, 3.1.8.
S14.4.1.2 General procedure	New title	New title.
S14.4.1.2.1 Design voltage	Table XXII Color test	SAE J578c, Feb 1977, 3.
S14.4.1.2.2 Components	Table XXII Color test	SAE J578c, Feb 1977, 3.
S14.4.1.2.3 Operating temperature	Table XXII Color test	SAE J578c, Feb 1977, A2(b).
S14.4.1.2.4 Visible surface	Table XXII Color test	SAE J578c, Feb 1977, A2(d).
S14.4.1.2.5 Test distance	Table XXII Color test	SAE J578c, Feb 1977, A2(c).
S14.4.1.3 Visual method	Table XXII Color test—procedure	SAE J578c, Feb 1977, 3.1.
S14.4.1.3.1 Procedure	Table XXII Color test—procedure	SAE J578c, Feb 1977, 3.1.
S14.4.1.3.2 Performance requirements	Table XXII Color test—performance requirements.	S5.1.5; SAE J578c, Feb 1977, 3.1.

APPENDIX B.—FMVSS NO. 108 REWRITE CROSS REFERENCE—Continued

Current FMVSS No. 108 or incorporated document citation	FMVSS No. 108 rewrite NPRM citation	FMVSS No. 108 rewrite final rule citation
S14.4.1.3.2.1 Red	Table XXII Color test—performance requirements.	SAE J578c, Feb 1977, 3.1.
S14.4.1.3.2.2 Yellow (Amber)	Table XXII Color test—performance requirements.	SAE J578c, Feb 1977, 3.1.
S14.4.1.3.2.3 White	Table XXII Color test—performance requirements.	SAE J578c, Feb 1977, 3.1.
S14.4.1.4 Tristimulus method	Table XXII Color test—procedure	SAE J578c, Feb 1977, 3.2.
S14.4.1.4.1 Procedure	Table XXII Color test—procedure	SAE J578c, Feb 1977, 3.2.
S14.4.1.4.1.1 Receiver spectral response	Table XXII Color test—procedure	SAE J578c, Feb 1977, 3.2.
S14.4.1.4.1.2 Integrating sphere	Table XXII Color test—procedure	SAE J578c, Feb 1977, 3.2.
S14.4.1.4.1.3 Non uniform color	Table XXII Color test—procedure	SAE J578c, Feb 1977, 3.2.
S14.4.1.4.2 Performance requirements	Table XXII Color test—performance requirements.	S5.1.5; SAE J578c, Feb 1977, 2.1, 2.2, and 2.3.
S14.4.1.4.2.1 Red	Table XXII Color test—performance requirements.	SAE J578c, Feb 1977, 2.1.
S14.4.1.4.2.2 Yellow (Amber)	Table XXII Color test—performance requirements.	SAE J578c, Feb 1977, 2.2.
S14.4.1.4.2.3 White	Table XXII Color test—performance requirements.	SAE J578c, Feb 1977, 2.3.
S14.4.2 Plastic optical materials tests	Table XXII Plastic optical material tests—application.	New title.
S14.4.2.1 Samples	Table XXII Plastic optical material tests—samples.	SAE J576, Jul 1991, 3.2.
S14.4.2.1.1 Molded samples	Table XXII Plastic optical material tests—samples.	SAE J576, Jul 1991, 3.2.1.
S14.4.2.1.2 Exposed area	Table XXII Plastic optical material tests—samples.	SAE J576, Jul 1991, 3.2.1.
S14.4.2.1.3 Thickness	Table XXII Plastic optical material tests—samples.	S5.1.2(d); SAE J576, Jul 1991, 3.2.2.
S14.4.2.1.4 Color	Table XXII Plastic optical material tests—samples.	SAE J576, Jul 1991, 4.1.
S14.4.2.1.5 Control samples	Table XXII Plastic optical material tests—samples.	SAE J576, Jul 1991, 3.2 Note.
S14.4.2.2 Outdoor exposure test	Table XXII Plastic optical material tests	SAE J576, Jul 1991, 3.3.
S14.4.2.2.1 Location and duration	Table XXII Plastic optical material tests	S5.1.2(g); SAE J576, Jul 1991, 3.3.1.
S14.4.2.2.2 Material composition	Table XXII Plastic optical material tests	SAE J576, Jul 1991, 3.1.
S14.4.2.2.3 Procedure	Table XXII Plastic optical material tests—procedure.	SAE J576, Jul 1991, 3.
S14.4.2.2.3.1 Mounting	Table XXII Plastic optical material tests—procedure.	SAE J576, Jul 1991, 3.3.2.
S14.4.2.2.3.2 Cleaning	Table XXII Plastic optical material tests—procedure.	SAE J576, Jul 1991, 3.3.3.
S14.4.2.2.4 Performance requirements	Table XXII Plastic optical material tests—performance requirements.	S5.1.2(a); SAE J576, Jul 1991, 4.2.
S14.4.2.2.4.1 Haze	Table XXII Plastic optical material tests—performance requirements.	S5.1.2(b); S5.1.2(c).
S14.4.2.2.4.1(a) Except reflex	Table XXII Plastic optical material tests—performance requirements.	S5.1.2(b).
S14.4.2.2.4.1(b) Reflex	Table XXII Plastic optical material tests—performance requirements.	S5.1.2(c).
S14.4.2.2.4.2 Headlamps	Table XXII Plastic optical material tests—performance requirements.	SAE J576, Jul 1991, 4.2.3.
S14.4.2.2.4.3 Physical changes	Table XXII Plastic optical material tests—performance requirements.	S5.1.2(c); SAE J576, Jul 1991, 4.2.4.
S14.4.2.2.4.4 Luminous transmittance	Table XXII Plastic optical material tests—performance requirements.	SAE J576, Jul 1991, 3.4.1 and 4.2.1.
S14.4.2.2.4.5 Color test	Table XXII Plastic optical material tests—performance requirements.	SAE J576, Jul 1991, 4.2.2.
S14.4.2.3 Heat test	Table XXII Plastic optical material tests	S5.1.2(e) and (f).
S14.4.2.3.1 Procedure	Table XXII Plastic optical material tests—procedure.	S5.1.2(f).
S14.4.2.3.2 Performance requirements	Table XXII Plastic optical material tests—performance requirements.	S5.1.2(e).
S14.5 Signal lamp and reflective device physical test procedures and performance requirements.	Table XXII	New title.
S14.5.1 Vibration test	Table XXII Vibration test	SAE J575d, Aug 1967, E; SAE J575e, Aug 1970, E.
S14.5.1.1 Procedure	Table XXII Vibration test—procedure	SAE J575d, Aug 1967, E; SAE J575e, Aug 1970, E.

APPENDIX B.—FMVSS NO. 108 REWRITE CROSS REFERENCE—Continued

Current FMVSS No. 108 or incorporated document citation	FMVSS No. 108 rewrite NPRM citation	FMVSS No. 108 rewrite final rule citation
S14.5.1.2 Performance requirements	Table XXII Vibration test—performance requirements.	SAE J575d, Aug 1967, E; SAE J575e, Aug 1970, E.
S14.5.2 Moisture test	Table XXII Moisture test	SAE J575d, Aug 1967, F; SAE J575e, Aug 1970, F.
S14.5.2.1 Procedure	Table XXII Moisture test—procedure	SAE J575d, Aug 1967, F; SAE J575e, Aug 1970, F.
S14.5.2.2 Performance requirements	Table XXII Moisture test—performance requirements.	SAE J575d, Aug 1967, F; SAE J575e, Aug 1970, F.
S14.5.3 Dust test	Table XXII Dust test	SAE J575d, Aug 1967, G; SAE J575e, Aug 1970, G.
S14.5.3.1 Samples	Table XXII Dust test	SAE J575d, Aug 1967, G; SAE J575e, Aug 1970, G.
S14.5.3.2 Procedure	Table XXII Dust test—procedure	SAE J575d, Aug 1967, G; SAE J575e, Aug 1970, G.
S14.5.3.2 Procedure (third sentence)	Table XXII Dust test—performance requirements.	SAE J575d, Aug 1967, G; SAE J575e, Aug 1970, G.
S14.5.3.3 Dust test—performance requirements.	Table XXII Dust test—performance requirements.	SAE J575d, Aug 1967, G; SAE J575e, Aug 1970, G.
S14.5.4 Corrosion test	Table XXII Corrosion test	SAE J575d, Aug 1967, H; SAE J575e, Aug 1970, H.
S14.5.4.1 Procedure	Table XXII Corrosion test—procedure	SAE J575d, Aug 1967, H; SAE J575e, Aug 1970, H.
S14.5.4.2 Performance requirements	Table XXII Corrosion test—performance requirements.	SAE J575d, Aug 1967, H; SAE J575e, Aug 1970, H.
S14.6 Headlamp physical test procedures and performance requirements.	Table XXIII	New title.
S14.6.1 Abrasion test	Table XXIII Abrasion test	S8.2 Abrasion.
S14.6.1.1 Procedure	Table XXIII Abrasion test—procedure	S8.2 Abrasion.
S14.6.1.1.1 Abrading pad	Table XXIII Abrasion test—procedure	S8.2(c)(1) and (3); S8.2(e).
S14.6.1.1.2 Abrading pad alignment	Table XXIII Abrasion test—procedure	S8.2(a) and (c)(4).
S14.6.1.1.3 Abrasion test procedure	Table XXIII Abrasion test—procedure	S8.2(b) and (d).
S14.6.1.2 Performance requirements	Table XXIII Abrasion test—performance requirements.	S7.4(h)(1); S8.1.
S14.6.2 Chemical resistance test	Table XXIII Chemical resistance test	S8.3 Chemical resistance.
S14.6.2.1 Procedure	Table XXIII Chemical resistance test—procedure.	S8.3 Chemical resistance.
S14.6.2.1.1 Test fluids	Table XXIII Chemical resistance test—procedure.	S8.3(b).
S14.6.2.1.2 Fluid application	Table XXIII Chemical resistance test—procedure.	S8.3(a).
S14.6.2.1.3 Test duration	Table XXIII Chemical resistance test—procedure.	S8.3(c).
S14.6.2.2 Performance requirements	Table XXIII Chemical resistance test—performance requirements.	S7.4(h)(2); S8.1.
S14.6.3 Corrosion test	Table XXIII Corrosion test	SAE J580, Dec 1986, 4.1.2 and 5.1.1.2.
S14.6.3.1 Procedure	Table XXIII Corrosion test—procedure	S7.8.5.1(c); SAE J575, Dec 1988, 4.4.
S14.6.3.2 Performance requirements	Table XXIII Corrosion test—performance requirements.	S7.8.5.1(c); SAE J575, Dec 1988, 4.4.
S14.6.4 Corrosion—connector test	Table XXIII Corrosion—connector test	S8.4 Corrosion.
S14.6.4.1 Procedure	Table XXIII Corrosion—connector test—procedure.	S8.4 Corrosion.
S14.6.4.1.1 Connector test	Table XXIII Corrosion—connector test—procedure(a).	S8.4(a).
S14.6.4.1.2 Salt spray	Table XXIII Corrosion—connector test—procedure(b).	S8.4(b).
S14.6.4.1.3 Cycle	Table XXIII Corrosion—connector test—procedure(b).	S8.4(b).
S14.6.4.1.4 Chamber	Table XXIII Corrosion—connector test—procedure(b).	S8.4(b).
S14.6.4.1.5 Wash	Table XXIII Corrosion—connector test—procedure(b).	S8.4(b).
S14.6.4.1.6 Connector test	Table XXIII Corrosion—connector test—procedure(c).	S8.4(c).
S14.6.4.2 Performance requirements	Table XXIII Corrosion—connector test—performance requirements.	S7.4(h)(3).
S14.6.4.2.1 Corrosion	Table XXIII Corrosion—connector test—performance requirements.	S7.4(h)(3).
S14.6.4.2.2 Adhesion	Table XXIII Corrosion—connector test—performance requirements.	S7.4(h)(3).
S14.6.4.2.3 Terminal corrosion	Table XXIII Corrosion—connector test—performance requirements.	S7.4(h)(3).

APPENDIX B.—FMVSS NO. 108 REWRITE CROSS REFERENCE—Continued

Current FMVSS No. 108 or incorporated document citation	FMVSS No. 108 rewrite NPRM citation	FMVSS No. 108 rewrite final rule citation
S14.6.5 Dust test	Table XXIII Dust test	S8.5 Dust.
S14.6.5.1 Procedure	Table XXIII Dust test—procedure	S8.5 Dust.
S14.6.5.1.1 Setup	Table XXIII Dust test—procedure	S8.5 Dust.
S14.6.5.1.2 Cycle	Table XXIII Dust test—procedure	S8.5 Dust.
S14.6.5.1.3 Test duration	Table XXIII Dust test—procedure	S8.5 Dust.
S14.6.5.2 Performance requirements	Table XXIII Dust test—performance requirements.	S7.4(h)(4); S8.1.
S14.6.6 Temperature cycle test and internal heat test.	Table XXIII	S8.6 Temperature and internal heat test.
S14.6.6.1 Samples	Table XXIII Temperature cycle test and internal heat test—procedure.	S8.6 Temperature and internal heat test.
S14.6.6.2 General procedure	Table XXIII Temperature cycle test and internal heat test—procedure.	S8.6 Temperature and internal heat test.
S14.6.6.2.1 General activation	Table XXIII Temperature cycle test and internal heat test—procedure.	S8.6 Temperature and internal heat test.
S14.6.6.2.2 Turn signal activation	Table XXIII Temperature cycle test and internal heat test—procedure.	S8.6 Temperature and internal heat test.
S14.6.6.2.3 Headlamp beam activation	Table XXIII Temperature cycle test and internal heat test—procedure.	S8.6 Temperature and internal heat test.
S14.6.6.3 Temperature cycle test	Table XXIII Temperature cycle test	S8.6.1 Temperature cycle.
S14.6.6.3.1 Procedure	Table XXIII Temperature cycle test—procedure.	S8.6.1 Temperature cycle.
S14.6.6.3.1.1 Cycle	Table XXIII Temperature cycle test—procedure.	S8.6.1 Temperature cycle.
S14.6.6.3.1.2 Activation	Table XXIII Temperature cycle test—procedure.	S8.6.1 Temperature cycle.
S14.6.6.3.1.3 Test chamber(s)	Table XXIII Temperature cycle test—procedure.	S8.6.1 Temperature cycle.
S14.6.6.3.1.4 Vents and drains	Table XXIII Temperature cycle test—procedure.	S8.6.1 Temperature cycle.
S14.6.6.3.2 Performance requirements	Table XXIII Temperature cycle test—performance requirements.	S7.4(h)(5)(i); S8.1.
S14.6.6.4 Internal heat test	Table XXIII Internal heat test	S8.6.2 Internal heat test.
S14.6.6.4.1 Procedure	Table XXIII Internal heat test—procedure	S8.6.2 Internal heat test.
S14.6.6.4.1.1 Photometric output reduction	Table XXIII Internal heat test—procedure	S8.6.2(a).
S14.6.6.4.1.2 HB1 or HB2 light sources	Table XXIII Internal heat test—procedure	S8.6.2(a).
S14.6.6.4.1.3 Photometric measurements	Table XXIII Internal heat test—procedure	S8.6.2(a).
S14.6.6.4.1.4 Setup	Table XXIII Internal heat test—procedure	S8.6.2(b).
S14.6.6.4.1.5 Cycle	Table XXIII Internal heat test—procedure	S8.6.2(b).
S14.6.6.4.1.6 Cleaning	Table XXIII Internal heat test—procedure	S8.6.2(c).
S14.6.6.4.2 Performance requirements	Table XXIII Internal heat test—performance requirements.	S7.4(h)(5)(ii); S8.1.
S14.6.7 Humidity test	Table XXIII Humidity test	New title.
S14.6.7.1 Procedure	Table XXIII Humidity test—procedure	New title.
S14.6.7.1.1 Test fixture	Table XXIII Humidity test—procedure(a)	S8.7(a).
S14.6.7.1.2 Headlamp mounting	Table XXIII Humidity test—procedure(a)	S8.7(a).
S14.6.7.1.3 Setup	Table XXIII Humidity test—procedure(b)	S8.7(b).
S14.6.7.1.4 Cycle	Table XXIII Humidity test—procedure(b)	S8.7(b).
S14.6.7.1.5 Air flow test setup	Table XXIII Humidity test—procedure(c)	S8.7(c).
S14.6.7.1.6 Air flow uniformity	Table XXIII Humidity test—procedure(d)	S8.7(d).
S14.6.7.1.7 Air flow procedure	Table XXIII Humidity test—procedure(e)	S8.7(e).
S14.6.7.1.8 Inspection	Table XXIII Humidity test—procedure(f)	S8.7(f).
S14.6.7.2 Performance requirements	Table XXIII Humidity test—performance requirements.	S7.4(h)(6).
S14.6.8 Vibration test	Table XXIII Vibration test	S8.8 Vibration.
S14.6.8.1 Samples	S6.8.2 [fourth sentence]	SAE J575, Dec 1988, 2.3.
S14.6.8.2 Procedure	Table XXIII Vibration test—procedure	S8.8; SAE J575, Dec 1988, 4.1.
S14.6.8.3 Performance requirements	Table XXIII Vibration test—performance requirements.	S7.3.2(c); S7.3.7(i); S7.3.8(d); S7.4(h)(7).
S14.6.9 Sealing test	Table XXIII Sealing test	S8.9 Sealing.
S14.6.9.1 Procedure	Table XXIII Sealing test—procedure	S8.9 Sealing.
S14.6.9.1.1 Immersion	Table XXIII Sealing test—procedure	S8.9 Sealing.
S14.6.9.1.2 Pressurized immersion	Table XXIII Sealing test—procedure	S8.9 Sealing.
S14.6.9.1.3 Cycle	Table XXIII Sealing test—procedure	S8.9 Sealing.
S14.6.9.1.4 Inspection	Table XXIII Sealing test—procedure	S8.9 Sealing.
S14.6.9.2 Performance requirements	Table XXIII Sealing test—performance requirements.	S7.4(g); S7.5(i); S8.9.
S14.6.10 Chemical resistance of reflectors of replaceable lens headlamps test.	Table XXIII Chemical resistance of reflectors of replaceable lens headlamps test.	S8.10 Chemical and corrosion resistance of reflectors of replaceable lens headlamps.

APPENDIX B.—FMVSS NO. 108 REWRITE CROSS REFERENCE—Continued

Current FMVSS No. 108 or incorporated document citation	FMVSS No. 108 rewrite NPRM citation	FMVSS No. 108 rewrite final rule citation
S14.6.10.1 Procedure	Table XXIII Chemical resistance of reflectors of replaceable lens headlamps test—procedure.	S8.10.1 Chemical resistance.
S14.6.10.1.1 Test fluids	Table XXIII Chemical resistance of reflectors of replaceable lens headlamps test—procedure.	S8.10.1(b).
S14.6.10.1.2 Fluid application	Table XXIII Chemical resistance of reflectors of replaceable lens headlamps test—procedure.	S8.10.1(a).
S14.6.10.1.3 Test duration	Table XXIII Chemical resistance of reflectors of replaceable lens headlamps test—procedure.	S8.10.1(c).
S14.6.10.2 Performance requirements	Table XXIII Chemical resistance of reflectors of replaceable lens headlamps test—performance requirements.	S7.4(h)(2); S8.1.
S14.6.11 Corrosion resistance of reflectors of replaceable lens headlamps test.	Table XXIII Corrosion resistance of reflectors of replaceable lens headlamps test.	S8.10 Chemical and corrosion resistance of reflectors of replaceable lens headlamps.
S14.6.11.1 Procedure	Table XXIII Corrosion resistance of reflectors of replaceable lens headlamps test—procedure.	S8.10.2 Corrosion.
S14.6.11.1.1 Salt spray	Table XXIII Corrosion resistance of reflectors of replaceable lens headlamps test—procedure.	S8.10.2(a).
S14.6.11.1.2 Drying and cleaning	Table XXIII Corrosion resistance of reflectors of replaceable lens headlamps test—procedure.	S8.10.2(b).
S14.6.11.2 Performance requirements	Table XXIII Corrosion resistance of reflectors of replaceable lens headlamps test—performance requirements.	S7.4(h)(3); S8.1.
S14.6.12 Inward force test	Table XXIII Inward force test	S7.8.5.1(b).
S14.6.12.1 Procedure	Table XXIII Inward force test—procedure	SAE J580, Dec 1986, 4.3.
S14.6.12.2 Performance requirements	Table XXIII Inward force test—performance requirements.	S7.8.5.1(b); SAE J580, Dec 1986, 5.1.3.
S14.6.13 Torque deflection test	Table XXIII Torque deflection test	S7.3.8(c) (2); S7.8.5.1(a).
S14.6.13.1 Procedure	Table XXIII Torque deflection test—procedure	S7.3.8(c) (2); S7.8.5.1(a).
S14.6.13.1.1 Mounting	Table XXIII Torque deflection test—procedure	S7.3.8(c) (2); S7.8.5.1(a).
S14.6.13.1.2 Deflectometers	Table XXIII Torque deflection test—procedure	S7.3.8(c)(2); S7.8.5.1(a).
S14.6.13.1.3 Deflectometer adapters	Table XXIII Torque deflection test—procedure	S7.3.8(c)(2); S7.8.5.1(a).
S14.6.13.1.4 Torque	Table XXIII Torque deflection test—procedure	S7.3.8(c) (2); S7.8.5.1(a).
S14.6.13.1.5 Torque application	Table XXIII Torque deflection test—procedure	S7.8.5.1(a).
S14.6.13.1.6 Group I aiming pads	Table XXIII Torque deflection test—procedure	S7.8.5.1(a).
S14.6.13.1.7 Group II aiming pads	Table XXIII Torque deflection test—procedure	S7.8.5.1(a).
S14.6.13.1.8 Non-adjustable locating plates	Table XXIII Torque deflection test—procedure	S7.8.5.1(a).
S14.6.13.2 Performance requirements	Table XXIII Torque deflection test—performance requirements.	S7.8.5.1(a); SAE J580, Dec 1986, 5.1.5.
S14.6.14 Retaining ring test	Table XXIII Retaining ring test	SAE J580, Dec 1986, 5.1.6.
S14.6.14.1 Procedure	Table XXIII Retaining ring test—procedure	S7.3.7(e)(7); SAE J580, Dec 1986, 5.1.6.
S14.6.14.2 Performance requirements	Table XXIII Retaining ring test—performance requirements.	SAE J580, Dec 1986, 5.1.6.
S14.6.15 Headlamp connector test	Table XXIII Headlamp connector test	S7.3.2(b); SAE J580, Dec 1986, Figure 1.
S14.6.15.1 Procedure	Table XXIII Headlamp connector test—procedure.	SAE J580, Dec 1986, 4.4.
S14.6.15.2 Performance requirements	Table XXIII Headlamp connector test—performance requirements.	SAE J580, Dec 1986, 5.1.4.
S14.6.16 Headlamp wattage test	Table XXIII Headlamp wattage test	SAE J1383, Apr 1985, 4.7.
S14.6.16.1 Procedure	Table XXIII Headlamp wattage test—procedure.	SAE J1383, Apr 1985, 4.7.
S14.6.16.2 Performance requirements	Table XXIII Headlamp wattage test—performance requirements.	S7.3.2(d); S7.3.3(b); S7.3.5(b); S7.3.6(b); S7.3.7(g); S7.3.8(e); S7.3.9(b).
S14.6.17 Aiming adjustment test—laboratory ...	Table XXIII Aiming adjustment test laboratory	S7.8 Aimability Performance Requirements.
S14.6.17.1 Procedure	Table XXIII Aiming adjustment test laboratory—procedure.	SAE J580, Dec 1986, 4.2.
S14.6.17.2 Performance requirements	Table XXIII Aiming adjustment test laboratory—performance requirements.	S7.8.2.1(c); S7.8.2.2(d).
S14.6.17.2.1 Sealed beam except Type F	Table XXIII Aiming adjustment test laboratory—performance requirements.	S7.8.3; S7.8.4; SAE J580, Dec 1986, 5.1.2.1 and 5.1.2.2.
S14.6.17.2.2 Type F, replaceable bulb, integral beam, and combination.	Table XXIII Aiming adjustment test laboratory—performance requirements.	S7.3.7(e)(5); S7.8.3; S7.8.4; SAE J580, Dec 1986, 5.1.2.1 and 5.1.2.2.
S14.6.17.2.3 Moveable reflector	Table XXIII Aiming adjustment test laboratory—performance requirements.	S7.8.2.2(a) and (c).
S14.6.18 Aiming adjustment test—on vehicle ...	Table XXIII Aiming adjustment test on vehicle	S7.8 Aimability Performance Requirements.

APPENDIX B.—FMVSS NO. 108 REWRITE CROSS REFERENCE—Continued

Current FMVSS No. 108 or incorporated document citation	FMVSS No. 108 rewrite NPRM citation	FMVSS No. 108 rewrite final rule citation
S14.6.18.1 Procedure	Table XXIII Aiming adjustment test on vehicle—procedure.	SAE J580, Dec 1986, 4.2.
S14.6.18.1.1 Setup	Table XXIII Aiming adjustment test on vehicle—procedure.	SAE J580, Dec 1986, 4.2.
S14.6.18.1.2 Vehicle pitch	Table XXIII Aiming adjustment test on vehicle—procedure.	S7.8.3.
S14.6.18.1.3 Adjustments	Table XXIII Aiming adjustment test on vehicle—procedure.	SAE J580, Dec 1986, 4.2.
S14.6.18.2 Performance requirements	Table XXIII Aiming adjustment test on vehicle—performance requirements.	S7.8 Aimability Performance Requirements.
S14.6.18.2.1 Vertical range	Table XXIII Aiming adjustment test on vehicle—performance requirements.	S7.8.3.
S14.6.18.2.2 Continuous vertical adjustment	Table XXIII Aiming adjustment test on vehicle—performance requirements.	S7.8.3.
S14.6.18.2.3 Aim interaction	Table XXIII Aiming adjustment test on vehicle—performance requirements.	S7.8.2.1(a) and (c).
S14.7 Replaceable light source physical test procedures and performance requirements.	Table XXIII	New title.
S14.7.1 Deflection test for replaceable light sources.	Table XXIII Deflection test for replaceable light sources.	S9 Deflection test for replaceable light sources.
S14.7.1.1 Procedure	Table XXIII Deflection test for replaceable light sources—procedure.	S9 Deflection test for replaceable light sources.
S14.7.1.1.1 Force application	Table XXIII Deflection test for replaceable light sources—procedure.	S9 Deflection test for replaceable light sources.
S14.7.1.1.2 Application sequence	Table XXIII Deflection test for replaceable light sources—procedure.	S9 Deflection test for replaceable light sources.
S14.7.1.1.3 Measurement	Table XXIII Deflection test for replaceable light sources—procedure.	S9 Deflection test for replaceable light sources.
S14.7.1.2 Performance requirements	Table XXIII Deflection test for replaceable light sources—performance requirements.	S7.7(g).
S14.7.2 Pressure test for replaceable light sources.	Table XXIII Pressure test for replaceable light sources.	S7.7(c).
S14.7.2.1 Procedure	Table XXIII Pressure test for replaceable light sources—procedure.	S7.7(c).
S14.7.2.1.1 Force application	Table XXIII Pressure test for replaceable light sources—procedure.	S7.7(c).
S14.7.2.1.2 Application sequence	Table XXIII Pressure test for replaceable light sources—procedure.	S7.7(c).
S14.7.2.2 Performance requirements	Table XXIII Pressure test for replaceable light sources—performance requirements.	S7.7(c).
S14.7.3 Replaceable light source power and flux measurement procedure.	S15.2; S15.3	S7.7(b); S7.7(d).
S14.7.3.1 Seasoning	S15.2; S15.3	S7.7(b); S7.7(d).
S14.7.3.1.1 Resistive filament source	S15.2; S15.3	S7.7(b); S7.7(d).
S14.7.3.1.2 Discharge source	S15.2; S15.3	S7.7(b); S7.7(d).
S14.7.3.2 Test voltage	S15.2; S15.3	S7.7(b); S7.7(d).
S14.7.3.3 Luminous flux measurement	S15.2; S15.3	S7.7(b); S7.7(d).
S14.7.3.3.1 Resistive filament light source setup.	S15.2; S15.3	S7.7(b); S7.7(d).
S14.7.3.3.2 Discharge light source setup	S15.2; S15.3	S7.7(b); S7.7(d).
S14.8 Vehicle headlamp aiming device (VHAD) physical test procedures and performance requirements.	Table XXIII	New title.
S14.8.1 Samples	Table XXIII	S7.8.5.2(d)(3)(ii).
S14.8.2 Scale graduation test	Table XXIII VHAD scale graduation test	S7.8.5.2(d)(3)(i).
S14.8.2.1 Procedure	Table XXIII VHAD scale graduation test—procedure.	S7.8.5.2(d)(3)(i).
S14.8.2.2 Performance requirements	Table XXIII VHAD scale graduation test—performance requirements.	S7.8.5.2(d)(3)(i).
S14.8.3 Cold scale graduation test	Table XXIII VHAD cold scale graduation test	S7.8.5.2(d)(3)(ii)(A).
S14.8.3.1 Procedure	Table XXIII VHAD cold scale graduation test—procedure.	S7.8.5.2(d)(3)(ii)(A).
S14.8.3.2 Performance requirements	Table XXIII VHAD cold scale graduation test—performance requirements.	S7.8.5.2(d)(3)(ii)(A).
S14.8.4 Hot scale graduation test	Table XXIII VHAD hot scale graduation test	S7.8.5.2(d)(3)(ii)(B).
S14.8.4.1 Procedure	Table XXIII VHAD hot scale graduation test—procedure.	S7.8.5.2(d)(3)(ii)(B).
S14.8.4.2 Performance requirements	Table XXIII VHAD hot scale graduation test—performance requirements.	S7.8.5.2(d)(3)(ii)(B).
S14.8.5 Thermal cycle test	Table XXIII VHAD thermal cycle test	S7.8.5.2(d)(3)(ii)(C).

APPENDIX B.—FMVSS NO. 108 REWRITE CROSS REFERENCE—Continued

Current FMVSS No. 108 or incorporated document citation	FMVSS No. 108 rewrite NPRM citation	FMVSS No. 108 rewrite final rule citation
S14.8.5.1 Procedure	Table XXIII VHAD thermal cycle test—procedure.	S7.8.5.2(d)(3)(ii)(C).
S14.8.5.2 Performance requirements	Table XXIII VHAD thermal cycle test—performance requirements.	S7.8.5.2(d)(3)(ii)(C).
S14.8.6 Corrosion test	Table XXIII VHAD corrosion test	S7.8.5.2(d)(3)(ii)(D).
S14.8.6.1 Procedure	Table XXIII VHAD corrosion test—procedure	S7.8.5.1(c); SAE J575, Dec 1988, 4.4.
S14.8.6.2 Performance requirements	Table XXIII VHAD corrosion test—performance requirements.	S7.8.5.1(c); SAE J575, Dec 1988, 4.4.
S14.8.7 Photometry test	Table XXIII VHAD photometry test	S7.8.5.2(d)(3)(ii)(E).
S14.8.7.1 Procedure	Table XXIII VHAD photometry test—procedure.	S7.8.5.2(d)(3)(ii)(E).
S14.8.7.2 Performance requirements	Table XXIII VHAD photometry test—performance requirements.	S7.8.5.2(d)(3)(ii)(E).
S14.9 Associated equipment physical test procedures and performance requirements.	Table XXI	New title.
S14.9.1 Turn Signal operating unit durability test.	Table XXI Turn signal operating unit durability test.	SAE J589, Apr 1964.
S14.9.1.1 Power supply specifications	Table XXI Turn signal operating unit durability test—procedure.	SAE J589, Apr 1964.
S14.9.1.2 Procedure	Table XXI Turn signal operating unit durability test—procedure.	SAE J589, Apr 1964.
S14.9.1.2.1 Circuit	Table XXI Turn signal operating unit durability test—procedure.	SAE J589, Apr 1964.
S14.9.1.2.2 Cycle	Table XXI Turn signal operating unit durability test—procedure.	SAE J589, Apr 1964.
S14.9.1.2.3 Voltage drop	Table XXI Turn signal operating unit durability test—procedure.	SAE J589, Apr 1964.
S14.9.1.3 Performance requirements	Table XXI Turn signal operating unit durability test—performance requirements.	S5.1.1.13; SAE J589, Apr 1964.
S14.9.1.3.1 Voltage drop (<2032 mm wide)	Table XXI Turn signal operating unit durability test—performance requirements.	S5.1.1.13.
S14.9.1.3.2 Voltage drop (2032 mm or wider) ..	Table XXI Turn signal operating unit durability test—performance requirements.	SAE J589, Apr 1964.
S14.9.1.3.3 Stop contacts	Table XXI Turn signal operating unit durability test—performance requirements.	SAE J589, Apr 1964.
S14.9.2 Vehicular hazard warning signal operating unit durability test.	Table XXI Vehicular hazard warning signal operating unit durability test.	SAE J910, Jan 1966.
S14.9.2.1 Procedure	Table XXI Vehicular hazard warning signal operating unit durability test—procedure.	SAE J910, Jan 1966, 4.
S14.9.2.1.1 Circuit	Table XXI Vehicular hazard warning signal operating unit durability test—procedure.	SAE J910, Jan 1966, 4.
S14.9.2.1.2 Cycle	Table XXI Vehicular hazard warning signal operating unit durability test—procedure.	SAE J910, Jan 1966, 4.
S14.9.2.1.3 Voltage drop	Table XXI Vehicular hazard warning signal operating unit durability test—procedure.	SAE J910, Jan 1966, 4.
S14.9.2.2 Performance requirements	Table XXI Vehicular hazard warning signal operating unit durability test—performance requirements.	SAE J910, Jan 1966, 4.
S14.9.3 Turn signal flasher and vehicular hazard warning signal warning flasher tests.	Table XXI Turn signal flasher and vehicular hazard warning signal flasher tests.	SAE J590b, Oct 1965; SAE J945, Feb 1966.
S14.9.3.1 Standard test circuit	SAE J823b, Apr 1968	SAE J823b, Apr 1968.
S14.9.3.1.1 Test circuit setup	SAE J823b, Apr 1968	SAE J823b, Apr 1968.
S14.9.3.1.1.1 Series resistance	SAE J823b, Apr 1968, 4	SAE J823b, Apr 1968, 4.
S14.9.3.1.1.2 A–B resistance	SAE J823b, Apr 1968, 5	SAE J823b, Apr 1968, 5.
S14.9.3.1.1.3 C–D voltage	SAE J823b, Apr 1968, 6	SAE J823b, Apr 1968, 6.
S14.9.3.1.1.4 Voltage adjustments—fixed load flashers.	SAE J823b, Apr 1968, 7	SAE J823b, Apr 1968, 7.
S14.9.3.1.1.5 Voltage adjustments—variable load flashers.	SAE J823b, Apr 1968, 8	SAE J823b, Apr 1968, 8.
S14.9.3.1.1.6 Measurements	SAE J823b, Apr 1968, 8	SAE J823b, Apr 1968, 8.
S14.9.3.2 Power supply specifications	SAE J823b, Apr 1968, 10 and 11	SAE J823b, Apr 1968, 10 and 11.
S14.9.3.2.1 Starting time, voltage drop, and flash rate & percent current “on” time tests.	SAE J590b, Oct 1965, 10	SAE J823b, Apr 1968, 10.
S14.9.3.2.1(a) Transients	SAE J590b, Oct 1965, 10	SAE J823b, Apr 1968, 10.
S14.9.3.2.1(b) Output voltage	SAE J823b, Apr 1968, 10(a)	SAE J823b, Apr 1968, 10(a).
S14.9.3.2.1(c) Output current	SAE J823b, Apr 1968, 10(b)	SAE J823b, Apr 1968, 10(b).
S14.9.3.2.1(d) Static regulation	SAE J823b, Apr 1968, 10(c)	SAE J823b, Apr 1968, 10(c).
S14.9.3.2.1(e) Dynamic regulation	SAE J823b, Apr 1968, 10(c)	SAE J823b, Apr 1968, 10(c).
S14.9.3.2.1(f) Ripple voltage	SAE J823b, Apr 1968, 10(d)	SAE J823b, Apr 1968, 10(d).
S14.9.3.2.2 Durability tests	SAE J590b, Oct 1965, 11	SAE J823b, Apr 1968, 11.
S14.9.3.2.2(a) Transients	SAE J590b, Oct 1965, 11	SAE J823b, Apr 1968, 11.

APPENDIX B.—FMVSS NO. 108 REWRITE CROSS REFERENCE—Continued

Current FMVSS No. 108 or incorporated document citation	FMVSS No. 108 rewrite NPRM citation	FMVSS No. 108 rewrite final rule citation
S14.9.3.2.2(b) Output voltage	SAE J590b, Oct 1965, 11(a)	SAE J823b, Apr 1968, 11(a).
S14.9.3.2.2(c) Output current	SAE J590b, Oct 1965, 11(b)	SAE J823b, Apr 1968, 11(b).
S14.9.3.2.2(d) Static regulation	SAE J590b, Oct 1965, 11(c)	SAE J823b, Apr 1968, 11(c).
S14.9.3.2.2(e) Dynamic regulation	SAE J590b, Oct 1965, 11(c)	SAE J823b, Apr 1968, 11(c).
S14.9.3.2.2(f) Ripple voltage	SAE J590b, Oct 1965, 11(d)	SAE J823b, Apr 1968, 11(d).
S14.9.3.3 Turn signal flasher starting time test	Table XXI Turn signal flasher starting time test.	SAE J590b, Oct 1965, 1.
S14.9.3.3.1 Samples	Table XXI Turn signal flasher starting time test—procedure.	SAE J590b, Oct 1965.
S14.9.3.3.2 Procedure	Table XXI Turn signal flasher starting time test—procedure.	SAE J590b, Oct 1965, 1.
S14.9.3.3.2.1 Setup	Table XXI Turn signal flasher starting time test—procedure.	S5.1.1.19; SAE J590b, Oct 1965, 1.
S14.9.3.3.2.2 Measurement	Table XXI Turn signal flasher starting time test—procedure.	SAE J590b, Oct 1965, 1.
S14.9.3.3.3 Performance requirements	Table XXI Turn signal flasher starting time test—performance requirements.	SAE J590b, Oct 1965, 1.
S14.9.3.3.3(a) Normally closed contacts	Table XXI Turn signal flasher starting time test—performance requirements.	SAE J590b, Oct 1965, 1.
S14.9.3.3.3(b) Normally open contacts	Table XXI Turn signal flasher starting time test—performance requirements.	SAE J590b, Oct 1965, 1.
S14.9.3.4 Turn signal flasher voltage drop test	Table XXI Turn signal flasher voltage drop test.	SAE J590b, Oct 1965.
S14.9.3.4.1 Samples	Table XXI Turn signal flasher voltage drop test—procedure.	SAE J590b, Oct 1965.
S14.9.3.4.2 Procedure	Table XXI Turn signal flasher voltage drop test—procedure.	SAE J590b, Oct 1965, 2.
S14.9.3.4.2.1 Setup	Table XXI Turn signal flasher voltage drop test—procedure.	S5.1.1.19; SAE J590b, Oct 1965, 2.
S14.9.3.4.2.2 Measurement	Table XXI Turn signal flasher voltage drop test—procedure.	SAE J590b, Oct 1965, 2.
S14.9.3.4.3 Performance requirements	Table XXI Turn signal flasher voltage drop test—performance requirements.	S5.1.1.20; SAE J590b, Oct 1965.
S14.9.3.5 Turn signal flasher flash rate and percent current “on” time test.	Table XXI Turn signal flasher flash rate and percent current “on” time test.	SAE J590b, Oct 1965.
S14.9.3.5.1 Samples	Table XXI Turn signal flasher flash rate and percent current “on” time test—procedure.	SAE J590b, Oct 1965, 3.
S14.9.3.5.2 Procedure	Table XXI Turn signal flasher flash rate and percent current “on” time test—procedure.	SAE J590b, Oct 1965, 3.
S14.9.3.5.2.1 Setup	Table XXI Turn signal flasher flash rate and percent current “on” time test—procedure.	S5.1.1.19; SAE J590b, Oct 1965, 3.
S14.9.3.5.2.2 Temperature and voltage	Table XXI Turn signal flasher flash rate and percent current “on” time test—procedure.	SAE J590b, Oct 1965, 3.
S14.9.3.5.2.3 Measurement	Table XXI Turn signal flasher flash rate and percent current “on” time test—procedure.	SAE J590b, Oct 1965, 3.
S14.9.3.5.3 Performance requirements	Table XXI Turn signal flasher flash rate and percent current “on” time test—performance requirements.	SAE J590b, Oct 1965, 3.
S14.9.3.5.3(a) Normally closed contacts	Table XXI Turn signal flasher flash rate and percent current “on” time test—performance requirements.	SAE J590b, Oct 1965, 3.
S14.9.3.5.3(b) Normally open contacts	Table XXI Turn signal flasher flash rate and percent current “on” time test—performance requirements.	SAE J590b, Oct 1965, 3.
S14.9.3.6 Turn signal flasher durability test	Table XXI Turn signal flasher durability test	SAE J590b, Oct 1965.
S14.9.3.6.1 Samples	Table XXI Turn signal flasher durability test—procedure.	SAE J590b, Oct 1965.
S14.9.3.6.2 Procedure	Table XXI Turn signal flasher durability test—procedure.	SAE J590b, Oct 1965.
S14.9.3.6.2.1 Setup	Table XXI Turn signal flasher durability test—procedure.	SAE J590b, Oct 1965.
S14.9.3.6.2.2 Temperature and voltage	Table XXI Turn signal flasher durability test—procedure.	SAE J590b, Oct 1965.
S14.9.3.6.2.3 Duration	Table XXI Turn signal flasher durability test—procedure.	SAE J590b, Oct 1965.
S14.9.3.6.3 Performance requirements	Table XXI Turn signal flasher durability test—performance requirements.	SAE J590b, Oct 1965.
S14.9.3.7 Vehicular hazard warning signal flasher starting time test.	Table XXI Vehicular hazard warning signal flasher starting time test.	SAE J945, Feb 1966.
S14.9.3.7.1 Samples	Table XXI Vehicular hazard warning signal flasher starting time test—procedure.	SAE J945, Feb 1966.

APPENDIX B.—FMVSS NO. 108 REWRITE CROSS REFERENCE—Continued

Current FMVSS No. 108 or incorporated document citation	FMVSS No. 108 rewrite NPRM citation	FMVSS No. 108 rewrite final rule citation
S14.9.3.7.2 Procedure	Table XXI Vehicular hazard warning signal flasher starting time test—procedure.	SAE J945, Feb 1966, 1.
S14.9.3.7.2.1 Setup	Table XXI Vehicular hazard warning signal flasher starting time test—procedure.	SAE J945, Feb 1966, 1.
S14.9.3.7.2.2 Measurement	Table XXI Vehicular hazard warning signal flasher starting time test—procedure.	SAE J945, Feb 1966, 1.
S14.9.3.7.3 Performance requirements	Table XXI Vehicular hazard warning signal flasher starting time test—performance requirements.	SAE J945, Feb 1966, 1.
S14.9.3.7.3(a) Normally closed contacts	Table XXI Vehicular hazard warning signal flasher starting time test—performance requirements.	SAE J945, Feb 1966, 1.
S14.9.3.7.3(b) Normally open contacts	Table XXI Vehicular hazard warning signal flasher starting time test—performance requirements.	SAE J945, Feb 1966, 1.
S14.9.3.8 Vehicular hazard warning signal flasher voltage drop test.	Table XXI Vehicular hazard warning signal flasher voltage drop test.	SAE J945, Feb 1966.
S14.9.3.8.1 Samples	Table XXI Vehicular hazard warning signal flasher voltage drop test—procedure.	SAE J945, Feb 1966.
S14.9.3.8.2 Procedure	Table XXI Vehicular hazard warning signal flasher voltage drop test—procedure.	SAE J945, Feb 1966, 2.
S14.9.3.8.2.1 Setup	Table XXI Vehicular hazard warning signal flasher voltage drop test—procedure.	SAE J945, Feb 1966, 2.
S14.9.3.8.2.2 Measurement	Table XXI Vehicular hazard warning signal flasher voltage drop test—procedure.	SAE J945, Feb 1966, 2.
S14.9.3.8.3 Performance requirements	Table XXI Vehicular hazard warning signal flasher voltage drop test—performance requirements.	S5.1.1.20; SAE J945, Feb 1966.
S14.9.3.9 Vehicular hazard warning signal flasher flash rate and percent current “on” time test.	Table XXI Vehicular hazard warning signal flasher flash rate and percent current “on” time test.	SAE J945, Feb 1966.
S14.9.3.9.1 Samples	Table XXI Vehicular hazard warning signal flasher flash rate and percent current “on” time test—procedure.	SAE J945, Feb 1966.
S14.9.3.9.2 Procedure	Table XXI Vehicular hazard warning signal flasher flash rate and percent current “on” time test—procedure.	SAE J945, Feb 1966, 3.
S14.9.3.9.2.1 Setup	Table XXI Vehicular hazard warning signal flasher flash rate and percent current “on” time test—procedure.	SAE J945, Feb 1966, 3.
S14.9.3.9.2.2 Temperature and voltage	Table XXI Vehicular hazard warning signal flasher flash rate and percent current “on” time test—procedure.	SAE J945, Feb 1966, 3.
S14.9.3.9.2.3 Measurement	Table XXI Vehicular hazard warning signal flasher flash rate and percent current “on” time test—procedure.	SAE J945, Feb 1966, 3.
S14.9.3.9.3 Performance requirements	Table XXI Vehicular hazard warning signal flasher flash rate and percent current “on” time test—performance requirements.	SAE J945, Feb 1966, 3.
S14.9.3.9.3(a) Normally closed contacts	Table XXI Vehicular hazard warning signal flasher flash rate and percent current “on” time test—performance requirements.	SAE J945, Feb 1966, 3.
S14.9.3.9.3(b) Normally open contacts	Table XXI Vehicular hazard warning signal flasher flash rate and percent current “on” time test—performance requirements.	SAE J945, Feb 1966, 3.
S14.9.3.10 Vehicular hazard warning signal flasher durability test.	Table XXI Vehicular hazard warning signal flasher durability test.	SAE J945, Feb 1966.
S14.9.3.10.1 Samples	Table XXI Vehicular hazard warning signal flasher durability test—procedure.	SAE J945, Feb 1966, 4.
S14.9.3.10.2 Procedure	Table XXI Vehicular hazard warning signal flasher durability test—procedure.	SAE J945, Feb 1966, 4.
S14.9.3.10.2.1 Setup	Table XXI Vehicular hazard warning signal flasher durability test—procedure.	SAE J945, Feb 1966, 4.
S14.9.3.10.2.2 Temperature and voltage	Table XXI Vehicular hazard warning signal flasher durability test—procedure.	SAE J945, Feb 1966, 4.
S14.9.3.10.2.3 Duration	Table XXI Vehicular hazard warning signal flasher durability test—procedure.	SAE J945, Feb 1966, 4.
S14.9.3.10.3 Performance requirements	Table XXI Vehicular hazard warning signal flasher durability test—performance requirements.	SAE J945, Feb 1966, 4.

APPENDIX B.—FMVSS NO. 108 REWRITE CROSS REFERENCE—Continued

Current FMVSS No. 108 or incorporated document citation	FMVSS No. 108 rewrite NPRM citation	FMVSS No. 108 rewrite final rule citation
S14.9.3.11 Semiautomatic headlamp beam switching device tests.	Table XXI Semiautomatic headlamp beam switching device tests.	SAE J565b, Feb 1969.
S14.9.3.11.1 Test conditions	Table XXI Semiautomatic headlamp beam switching device tests—applicable item.	SAE J565b, Feb 1969, 4.2.
S14.9.3.11.2 Sensitivity test	Table XXI Semiautomatic headlamp beam switching device sensitivity test.	SAE J565b, Feb 1969, 4.
S14.9.3.11.2.1 Samples	Table XXI Semiautomatic headlamp beam switching device sensitivity test—procedure.	SAE J565b, Feb 1969, 4.1.
S14.9.3.11.2.2 Procedure	Table XXI Semiautomatic headlamp beam switching device sensitivity test—procedure.	SAE J565b, Feb 1969, 4.2.
S14.9.3.11.2.2.1 Adjustment	Table XXI Semiautomatic headlamp beam switching device sensitivity test—procedure.	SAE J565b, Feb 1969, 4.2.
S14.9.3.11.2.2.2 Switching	Table XXI Semiautomatic headlamp beam switching device sensitivity test—procedure.	SAE J565b, Feb 1969, 4.2.
S14.9.3.11.2.2.3 Sensitivity curves	Table XXI Semiautomatic headlamp beam switching device sensitivity test—procedure.	SAE J565b, Feb 1969, 4.2.
S14.9.3.11.2.3 Performance requirements	Table XXI Semiautomatic headlamp beam switching device sensitivity test—performance requirements.	SAE J565b, Feb 1969, 4.2.
S14.9.3.11.2.3.1 Operating limits	Table XXI Semiautomatic headlamp beam switching device sensitivity test—performance requirements.	SAE J565b, Feb 1969, 4.2.
S14.9.3.11.2.3.2 Sensitivity voids	Table XXI Semiautomatic headlamp beam switching device sensitivity test—performance requirements.	SAE J565b, Feb 1969, 4.2.
S14.9.3.11.3 Voltage regulation test	Table XXI Semiautomatic headlamp beam switching device voltage regulation test.	SAE J565b, Feb 1969, 4.3.
S14.9.3.11.3.1 Procedure	Table XXI Semiautomatic headlamp beam switching device voltage regulation test—procedure.	SAE J565b, Feb 1969, 4.3.
S14.9.3.11.3.1.1 Adjustment	Table XXI Semiautomatic headlamp beam switching device voltage regulation test—procedure.	SAE J565b, Feb 1969, 4.3.
S14.9.3.11.3.1.2 Measurement	Table XXI Semiautomatic headlamp beam switching device voltage regulation test—procedure.	SAE J565b, Feb 1969, 4.3.
S14.9.3.11.3.2 Performance requirements	Table XXI Semiautomatic headlamp beam switching device voltage regulation test—performance requirements.	SAE J565b, Feb 1969, 4.3.
S14.9.3.11.4 Manual override test	Table XXI Semiautomatic headlamp beam switching device manual override test.	SAE J565b, Feb 1969, 4.4.
S14.9.3.11.4.1 Procedure	Table XXI Semiautomatic headlamp beam switching device manual override test—procedure.	SAE J565b, Feb 1969, 4.4.
S14.9.3.11.4.1.1 Adjustment	Table XXI Semiautomatic headlamp beam switching device manual override test—procedure.	SAE J565b, Feb 1969, 4.4.
S14.9.3.11.4.1.2 Exposure	Table XXI Semiautomatic headlamp beam switching device manual override test—procedure.	SAE J565b, Feb 1969, 4.4.
S14.9.3.11.4.1.3 Override	Table XXI Semiautomatic headlamp beam switching device manual override test—procedure.	SAE J565b, Feb 1969, 4.4.
S14.9.3.11.4.1.4 Switch to upper beam	Table XXI Semiautomatic headlamp beam switching device manual override test—procedure.	SAE J565b, Feb 1969, 4.4.
S14.9.3.11.4.1.5 Switch to lower beam	Table XXI Semiautomatic headlamp beam switching device manual override test—procedure.	SAE J565b, Feb 1969, 4.4.
S14.9.3.11.4.2 Performance requirements	Table XXI Semiautomatic headlamp beam switching device manual override test—performance requirements.	SAE J565b, Feb 1969, 4.4.
S14.9.3.11.5 Warmup test	Table XXI Semiautomatic headlamp beam switching device warmup test.	SAE J565b, Feb 1969, 4.5.
S14.9.3.11.5.1 Procedure	Table XXI Semiautomatic headlamp beam switching device warmup test—procedure.	SAE J565b, Feb 1969, 4.5.
S14.9.3.11.5.1.1 Adjustment	Table XXI Semiautomatic headlamp beam switching device warmup test—procedure.	SAE J565b, Feb 1969, 4.5.
S14.9.3.11.5.1.2 Measurement	Table XXI Semiautomatic headlamp beam switching device warmup test—procedure.	SAE J565b, Feb 1969, 4.5.

APPENDIX B.—FMVSS NO. 108 REWRITE CROSS REFERENCE—Continued

Current FMVSS No. 108 or incorporated document citation	FMVSS No. 108 rewrite NPRM citation	FMVSS No. 108 rewrite final rule citation
S14.9.3.11.5.2 Performance requirements	Table XXI Semiautomatic headlamp beam switching device warmup test—performance requirements.	SAE J565b, Feb 1969, 4.5.
S14.9.3.11.6 Temperature test	Table XXI Semiautomatic headlamp beam switching device temperature test.	SAE J565b, Feb 1969, 4.7.
S14.9.3.11.6.1 Procedure	Table XXI Semiautomatic headlamp beam switching device temperature test—procedure.	SAE J565b, Feb 1969, 4.7.
S14.9.3.11.6.1.1 Exposure	Table XXI Semiautomatic headlamp beam switching device temperature test—procedure.	SAE J565b, Feb 1969, 4.7.
S14.9.3.11.6.1.2 Temperature	Table XXI Semiautomatic headlamp beam switching device temperature test—procedure.	SAE J565b, Feb 1969, 4.7.
S14.9.3.11.6.1.3 Measurement	Table XXI Semiautomatic headlamp beam switching device temperature test—procedure.	SAE J565b, Feb 1969, 4.7.
S14.9.3.11.6.2 Performance requirements	Table XXI Semiautomatic headlamp beam switching device temperature test—performance requirements.	SAE J565b, Feb 1969, 4.7.
S14.9.3.11.7 Dust test	Table XXI Semiautomatic headlamp beam switching device dust test.	SAE J565b, Feb 1969, 4.8.
S14.9.3.11.7.1 Procedure	Table XXI Semiautomatic headlamp beam switching device dust test—procedure.	SAE J565b, Feb 1969, 4.8.
S14.9.3.11.7.1.1 Sensitivity	Table XXI Semiautomatic headlamp beam switching device dust test—procedure.	SAE J565b, Feb 1969, 4.8.
S14.9.3.11.7.1.2 Dust exposure	Table XXI Semiautomatic headlamp beam switching device dust test—procedure.	SAE J565b, Feb 1969, 4.8.
S14.9.3.11.7.1.3 Measurement	Table XXI Semiautomatic headlamp beam switching device dust test—procedure.	SAE J565b, Feb 1969, 4.8.
S14.9.3.11.7.2 Performance requirements	Table XXI Semiautomatic headlamp beam switching device dust test—performance requirements.	SAE J565b, Feb 1969, 4.8.
S14.9.3.11.8 Corrosion test	Table XXI Semiautomatic headlamp beam switching device corrosion test.	SAE J565b, Feb 1969, 4.9.
S14.9.3.11.8.1 Procedure	Table XXI Semiautomatic headlamp beam switching device corrosion test—procedure.	SAE J565b, Feb 1969, 4.9.
S14.9.3.11.8.1.1 Sensitivity	Table XXI Semiautomatic headlamp beam switching device corrosion test—procedure.	SAE J565b, Feb 1969, 4.9.
S14.9.3.11.8.1.2 Applicability	Table XXI Semiautomatic headlamp beam switching device corrosion test—procedure.	SAE J565b, Feb 1969, 4.9.
S14.9.3.11.8.1.3 Sockets	Table XXI Semiautomatic headlamp beam switching device corrosion test—procedure.	SAE J565b, Feb 1969, 4.9.
S14.9.3.11.8.1.4 Measurement	Table XXI Semiautomatic headlamp beam switching device corrosion test—procedure.	SAE J565b, Feb 1969, 4.9.
S14.9.3.11.8.2 Performance requirements	Table XXI Semiautomatic headlamp beam switching device corrosion test—performance requirements.	SAE J565b, Feb 1969, 4.9.
S14.9.3.11.9 Vibration test	Table XXI Semiautomatic headlamp beam switching device vibration test.	SAE J565b, Feb 1969, 4.10.
S14.9.3.11.9.1 Procedure	Table XXI Semiautomatic headlamp beam switching device vibration test—procedure.	SAE J565b, Feb 1969, 4.10.
S14.9.3.11.9.1.1 Sensitivity	Table XXI Semiautomatic headlamp beam switching device vibration test—procedure.	SAE J565b, Feb 1969, 4.10.
S14.9.3.11.9.1.2 Acceleration	Table XXI Semiautomatic headlamp beam switching device vibration test—procedure.	SAE J565b, Feb 1969, 4.10(a).
S14.9.3.11.9.1.3 Frequency	Table XXI Semiautomatic headlamp beam switching device vibration test—procedure.	SAE J565b, Feb 1969, 4.10(b).
S14.9.3.11.9.1.4 Operation	Table XXI Semiautomatic headlamp beam switching device vibration test—procedure.	SAE J565b, Feb 1969, 4.10(c).
S14.9.3.11.9.1.5 Measurement	Table XXI Semiautomatic headlamp beam switching device vibration test—procedure.	SAE J565b, Feb 1969, 4.10.
S14.9.3.11.9.2 Performance requirements	Table XXI Semiautomatic headlamp beam switching device vibration test—performance requirements.	SAE J565b, Feb 1969, 4.10.
S14.9.3.11.9.2.1 Beam switching	Table XXI Semiautomatic headlamp beam switching device vibration test—performance requirements.	SAE J565b, Feb 1969, 4.10.
S14.9.3.11.9.2.2 Mechanical aim	Table XXI Semiautomatic headlamp beam switching device vibration test—performance requirements.	SAE J565b, Feb 1969, 4.10.

APPENDIX B.—FMVSS NO. 108 REWRITE CROSS REFERENCE—Continued

Current FMVSS No. 108 or incorporated document citation	FMVSS No. 108 rewrite NPRM citation	FMVSS No. 108 rewrite final rule citation
S14.9.3.11.10 Sunlight test	Table XXI Semiautomatic headlamp beam switching device sunlight test.	SAE J565b, Feb 1969, 4.11.
S14.9.3.11.10.1 Procedure	Table XXI Semiautomatic headlamp beam switching device sunlight test—procedure.	SAE J565b, Feb 1969, 4.11.
S14.9.3.11.10.1.1 Exposure	Table XXI Semiautomatic headlamp beam switching device sunlight test—procedure.	SAE J565b, Feb 1969, 4.11.
S14.9.3.11.10.1.2 Rest	Table XXI Semiautomatic headlamp beam switching device sunlight test—procedure.	SAE J565b, Feb 1969, 4.11.
S14.9.3.11.10.2 Performance requirements	Table XXI Semiautomatic headlamp beam switching device sunlight test—performance requirements.	SAE J565b, Feb 1969, 4.11.
S14.9.3.11.11 Durability test	Table XXI Semiautomatic headlamp beam switching device durability test.	SAE J565b, Feb 1969, 4.12.
S14.9.3.11.11.1 Procedure	Table XXI Semiautomatic headlamp beam switching device durability test—procedure.	SAE J565b, Feb 1969, 4.12.
S14.9.3.11.11.1.1 Sensitivity	Table XXI Semiautomatic headlamp beam switching device durability test—procedure.	SAE J565b, Feb 1969, 4.12.
S14.9.3.11.11.1.2 Cycle	Table XXI Semiautomatic headlamp beam switching device durability test—procedure.	SAE J565b, Feb 1969, 4.12(a) and (b).
S14.9.3.11.11.1.3 Measurement	Table XXI Semiautomatic headlamp beam switching device durability test—procedure.	SAE J565b, Feb 1969, 4.12.
S14.9.3.11.11.2 Performance requirements	Table XXI Semiautomatic headlamp beam switching device durability test—performance requirements.	SAE J565b, Feb 1969, 4.12.
S14.9.3.11.12 Return to upper beam test	Table XXI Semiautomatic headlamp beam switching device return to upper beam test.	SAE J565b, Feb 1969, 4.15.
S14.9.3.11.12.1 Procedure	Table XXI Semiautomatic headlamp beam switching device return to upper beam test—procedure.	SAE J565b, Feb 1969, 4.15.
S14.9.3.11.12.1.1 Sensitivity	Table XXI Semiautomatic headlamp beam switching device return to upper beam test—procedure.	SAE J565b, Feb 1969, 4.15.
S14.9.3.11.12.1.2 Exposure	Table XXI Semiautomatic headlamp beam switching device return to upper beam test—procedure.	SAE J565b, Feb 1969, 4.15.
S14.9.3.11.12.2 Performance requirements	Table XXI Semiautomatic headlamp beam switching device return to upper beam test—performance requirements.	SAE J565b, Feb 1969, 4.15.
Figure 1	Figure 1	SAE J578c, Feb 1977, Figure 1.
Figure 2	Figure 2	SAE J590b, Oct 1965, Figure 1.
Figure 2	Figure 2	SAE J945, Feb 1966, Figure 1.
Figure 3	Figure 3	Figure 4–1.
Figure 3	Figure 3	Figure 4–2.
Figure 3	Figure 3	Figure 4–3.
Figure 3	Figure 3	Figure 4–4.
Figure 4	Figure 4	SAE J580, Dec 1986, Figure 1.
Figure 5	Figure 5	Figure 5.
Figure 6	Figure 6	Figure 6.
Figure 7	Figure 7	Figure 7.
Figure 8	Figure 8	Figure 8.
Figure 9	Figure 9	Figure 9.
Figure 10	Figure 10	Figure 25.
Figure 11	Figure 11	Figure 30–1.
Figure 11	Figure 11	Figure 30–2.
Figure 11	Figure 11	Figure 30–3.
Figure 11	Figure 11	Figure 30–4.
Figure 12–1	Figure 12–1	New.
Figure 12–2	Figure 12–2	New.
Figure 13	Figure 13	Figure 31.
Figure 14	Figure 14	Figure 16.
Figure 15	Figure 15	Figure 22.
Figure 16	Figure 16	SAE J580, Dec 1986, Figure 3.
Figure 17	Figure 17	SAE J580, Dec 1986, Figure 4.
Figure 18	Figure 18	SAE J580, Dec 1986, Figure 2.
Figure 19	Table XIII	SAE J587, Oct 1981, Figures 1 & 2.
Figure 20	Not included	SAE J587, Oct 1981, Figure 3.
Figure 21	SAE J577, Apr 1964, Figure 1 and Table 1	SAE J577, Apr 1964, Figure 1 and Table 1.
Figure 22	SAE J823b, Apr 1968, Figure 1	SAE J823b, Apr 1968, Figure 1.
Table I–a Activation Taillamps	Table I Activation Taillamps	S5.5.10(d).
Table I–a Activation Taillamps	Table I Activation Taillamps	S5.5.3.
Table I–a Activation Taillamps	Table I Activation Taillamps	S5.5.7(a).

APPENDIX B.—FMVSS NO. 108 REWRITE CROSS REFERENCE—Continued

Current FMVSS No. 108 or incorporated document citation	FMVSS No. 108 rewrite NPRM citation	FMVSS No. 108 rewrite final rule citation
Table I-a Activation Taillamps	Table I Activation Taillamps	S5.5.7(b).
Table I-a Activation—Backup lamps	Table I Activation—Backup lamps	S5.5.10(d).
Table I-a Activation—Backup lamps	Table I Activation—Backup lamps	SAE J593c, Feb 1968.
Table I-a Activation—Clearance lamps	Table I Activation—Clearance lamps	S5.5.10(d).
Table I-a Activation—DRL	Table I Activation—DRL	S5.5.10(d).
Table I-a Activation—DRL	Table I Activation—DRL	S5.5.11(a) Daytime running lamps (DRL).
Table I-a Activation—DRL	Table I Activation—DRL	S5.5.11(a)(5).
Table I-a Activation—Headlamp	Table I Activation—Headlamp	S5.5.8.
Table I-a Activation—Headlamp	Table I Activation—Headlamp	S5.5.9.
Table I-a Activation—Headlamp	Table I Activation—Headlamp	S5.5.10(b).
Table I-a Activation—Headlamp	Table I Activation—Headlamp	S5.5.10(d).
Table I-a Activation—High mounted stop lamps	Table I Activation—High mounted stop lamps	S5.5.10(d).
Table I-a Activation—Identification lamps	Table I Activation—Identification lamps	S5.5.10(d).
Table I-a Activation—License plate lamps	Table I Activation—License plate lamps	S5.5.10(d).
Table I-a Activation—License plate lamps	Table I Activation—License plate lamps	S5.5.7(a).
Table I-a Activation—License plate lamps	Table I Activation—License plate lamps	S5.5.7(b).
Table I-a Activation—Parking lamps	Table I Activation—Parking lamps	S5.5.10(d).
Table I-a Activation—Parking lamps	Table I Activation—Parking lamps	S5.5.7(a).
Table I-a Activation—Parking lamps	Table I Activation—Parking lamps	S5.5.7(b).
Table I-a Activation—High mounted stop lamps	Table I Activation—High mounted stop lamps	S5.5.4.
Table I-a Activation—School bus signal lamps	Table I Activation—School bus signal lamps ..	S5.1.4(b)(ii).
Table I-a Activation—School bus signal lamps	Table I Activation—School bus signal lamps ..	S5.5.10(a).
Table I-a Activation—School bus signal lamps	Table I Activation—School bus signal lamps ..	SAE J887, Jul 1964.
Table I-a Activation—Side marker lamps	Table I Activation—Side marker lamps	S5.5.10(b).
Table I-a Activation—Side marker lamps	Table I Activation—Side marker lamps	S5.5.10(d).
Table I-a Activation—Side marker lamps	Table I Activation—Side marker lamps	S5.5.7(a).
Table I-a Activation—Side marker lamps	Table I Activation—Side marker lamps	S5.5.7(b).
Table I-a Activation—Stop lamps	Table I Activation—Stop lamps	Interpretation—Faber 5/26/00.
Table I-a Activation—Stop lamps	Table I Activation—Stop lamps	S5.1.1.11 Stop lamp and turn signal lamp activation interaction.
Table I-a Activation—Stop lamps	Table I Activation—Stop lamps	S5.5.4.
Table I-a Activation—Turn signals	Table I Activation—Turn signals	S5.5.10(a).
Table I-a Lighting device	Table I Lighting device	S5.1.1.27(a).
Table I-a Lighting device	Table I Lighting device	S5.1.1.27(b).
Table I-a Lighting device	Table I Lighting device	S5.1.1.4 Alternative side reflex material.
Table I-a Lighting device	Table I Lighting device	S5.5.11(a) Daytime running lamps (DRL).
Table I-a Lighting device	Table I Lighting device	S5.5.11(a)(3).
Table I-a Lighting device	Table I Lighting device	S5.5.11(b).
Table I-a Lighting device	Table I Lighting device	Table I.
Table I-a Lighting device	Table I Lighting device	Table II.
Table I-a Lighting device	Table I Lighting device	Table III.
Table I-a Lighting device	Table I Lighting device	Table IV.
Table I-a Additional Lamps Required on All School Buses except Multifunction School Activity Buses.	Table I Additional Lamps Required on All School Buses except Multifunction School Activity Buses.	S5.1.4 School bus signal lamps.
Table I-a Mounting height	Table I Mounting height	S5.5.11(b).
Table I-a Mounting height	Table I Mounting height	Table I.
Table I-a Mounting height	Table I Mounting height	Table II.
Table I-a Mounting height	Table I Mounting height	Table III.
Table I-a Mounting height	Table I Mounting height	Table IV.
Table I-a Mounting height—Clearance lamps ..	Table I Mounting Height—Clearance lamps	S5.3.1.4 Rear clearance lamp mounting.
Table I-a Mounting height—Clearance lamps—rear.	64 FR 16358	64 FR 16358.
Table I-a Mounting height—Identification lamps—rear.	64 FR 16358	64 FR 16358.
Table I-a Mounting location	Table I Mounting location	Table I.
Table I-a Mounting location	Table I Mounting location	Table II.
Table I-a Mounting location	Table I Mounting location	Table III.
Table I-a Mounting location	Table I Mounting location	Table IV.
Table I-a Mounting location—High mounted stop lamp.	Table I Mounting location—High mounted stop lamp.	S5.3.1.8(a)(1).
Table I-a Mounting location—Clearance lamps	Table I Mounting location— Clearance lamps	S5.3.1.6 Truck tractor clearance lamps.
Table I-a Mounting location—Clearance lamps	Table I Mounting location— Clearance lamps	S5.3.2.1.
Table I-a Mounting location—Reflex reflectors	Table I Mounting location—Reflex reflectors ...	S5.3.1.2 Truck tractor rear reflex.
Table I-a Number and color	Table I Number and color	S5.1.1.1 Truck tractor exemption—TS.
Table I-a Number and color	Table I Number and color	S5.1.1.10 Multiple license plate lamps and backup lamps.
Table I-a Number and color	Table I Number and color	S5.1.1.2 Truck tractor exemption.
Table I-a Number and color	Table I Number and color	S5.5.11(a)(3).
Table I-a Number and color	Table I Number and color	Table I.
Table I-a Number and color	Table I Number and color	Table II.

APPENDIX B.—FMVSS NO. 108 REWRITE CROSS REFERENCE—Continued

Current FMVSS No. 108 or incorporated document citation	FMVSS No. 108 rewrite NPRM citation	FMVSS No. 108 rewrite final rule citation
Table I-a Number and color	Table I Number and color	Table III.
Table I-a Number and color	Table I Number and color	Table IV.
Table I-a Number and color—Intermediate side marker lamps.	Table I Number and color—Intermediate side marker lamps.	S5.1.1.3 Intermediate side marker exemption.
Table I-a Number and color—School bus signal lamps.	Table I Number and color—School bus signal lamps.	S5.1.4(a).
Table I-a Number and color—School bus signal lamps.	Table I Number and color—School bus signal lamps.	S5.1.4(b)(i).
Table I-b Activation Taillamps	Table I Activation Taillamps	S5.5.10(d).
Table I-b Activation—Clearance lamps	Table I Activation—Clearance lamps	S5.5.10(d).
Table I-b Activation—Side marker lamps	Table I Activation—Side marker lamps	S5.5.10(b).
Table I-b Activation—Side marker lamps	Table I Activation—Side marker lamps	S5.5.10(d).
Table I-b Activation—Stop lamps	Table I Activation—Stop lamps	Interpretation—Faber 5/26/00.
Table I-b Activation—Stop lamps	Table I Activation—Stop lamps	S5.1.1.11 Stop lamp and turn signal lamp activation interaction.
Table I-b Activation—Stop lamps	Table I Activation—Stop lamps	S5.5.10(d).
Table I-b Activation—Stop lamps	Table I Activation—Stop lamps	S5.5.4.
Table I-b Activation—Turn signals	Table I Activation—Turn signals	S5.5.10(a).
Table I-b Lighting device	Table I Lighting device	S5.1.1.4 Alternative side reflex material.
Table I-b Lighting device	Table I Lighting device	Table I.
Table I-b Lighting device	Table I Lighting device	Table II.
Table I-b Lighting device	Table I Lighting device	Table III.
Table I-b Lighting device	Table I Lighting device	Table IV.
Table I-b Mounting height	Table I Mounting height	Table I.
Table I-b Mounting height	Table I Mounting height	Table II.
Table I-b Mounting height	Table I Mounting height	Table III.
Table I-b Mounting height	Table I Mounting height	Table IV.
Table I-b Mounting Height—Clearance lamps ..	Table I Mounting Height—Clearance lamps ..	S5.3.1.4 Rear clearance lamp mounting.
Table I-b Mounting height—Clearance lamps—rear.	64 FR 16358	64 FR 16358.
Table I-b Mounting height—Identification lamps—rear.	64 FR 16358	64 FR 16358.
Table I-b Mounting location	Table I Mounting location	Table I.
Table I-b Mounting location	Table I Mounting location	Table II.
Table I-b Mounting location	Table I Mounting location	Table III.
Table I-b Mounting location	Table I Mounting location	Table IV.
Table I-b Mounting location—Clearance lamps	Table I Mounting location—Clearance lamps ..	S5.3.2.1.
Table I-b Mounting location—Reflex reflectors	Table I Mounting location—Reflex reflectors ...	S5.3.1.3 Trailer front reflex and side marker.
Table I-b Mounting location—Side marker lamps.	Table I Mounting location—Side marker lamps	S5.3.1.3 Trailer front reflex and side marker.
Table I-b Number and color	Table I Number and color	S5.1.1.10 Multiple license plate lamps and backup lamps.
Table I-b Number and color	Table I Number and color	S5.1.1.14 Trailer exemption—rear.
Table I-b Number and color	Table I Number and color	S5.1.1.15 Trailer exemption—front.
Table I-b Number and color	Table I Number and color	Table I.
Table I-b Number and color	Table I Number and color	Table II.
Table I-b Number and color	Table I Number and color	Table III.
Table I-b Number and color	Table I Number and color	Table IV.
Table I-b Number and color—Clearance lamp	Table I Number and color—Clearance lamp ...	S5.1.1.9 Boat trailer exemption.
Table I-b Number and color—Intermediate side marker lamps.	Table I Number and color—Intermediate side marker lamps.	S5.1.1.3 Intermediate side marker exemption.
Table I-b Reflex reflectors	S6.1.1.1.1 Conspicuity and reflex	S5.1.1.29 Conspicuity system replace reflex on trailers.
Table I-c Activation Taillamps	Table I Activation Taillamps	S5.5.10(d).
Table I-c Activation Taillamps	Table I Activation Taillamps	S5.5.3.
Table I-c Activation Taillamps	Table I Activation Taillamps	S5.5.7(a).
Table I-c Activation Taillamps	Table I Activation Taillamps	S5.5.7(b).
Table I-c Activation—Headlamp	Table I Activation—Headlamp	S5.5.9.
Table I-c Activation—Headlamp	Table I Activation—Headlamp	S5.5.10(d).
Table I-c Activation—License plate lamps	Table I Activation—License plate lamps	S5.5.10(d).
Table I-c Activation—License plate lamps	Table I Activation—License plate lamps	S5.5.7(a).
Table I-c Activation—License plate lamps	Table I Activation—License plate lamps	S5.5.7(b).
Table I-c Activation—Motorcycle headlamps	Table I Activation—Motorcycle headlamps	S5.5.10(b).
Table I-c Activation—Motorcycle headlamps	Table I Activation—Motorcycle headlamps	S5.5.10(c).
Table I-c Activation—Motorcycle headlamps	Table I Activation—Motorcycle headlamps	S5.5.9.
Table I-c Activation—Stop lamps	Table I Activation—Stop lamps	Interpretation—Faber 5/26/00.
Table I-c Activation—Stop lamps	Table I Activation—Stop lamps	S5.1.1.11 Stop lamp and turn signal lamp activation interaction.
Table I-c Activation—Stop lamps	Table I Activation—Stop lamps	S5.5.10(d).
Table I-c Activation—Stop lamps	Table I Activation—Stop lamps	S5.5.10(d).
Table I-c Activation—Stop lamps	Table I Activation—Stop lamps	S5.5.4.

APPENDIX B.—FMVSS NO. 108 REWRITE CROSS REFERENCE—Continued

Current FMVSS No. 108 or incorporated document citation	FMVSS No. 108 rewrite NPRM citation	FMVSS No. 108 rewrite final rule citation
Table I-c Activation—Turn signals	Table I Activation—Turn signals	S5.5.10(a).
Table I-c Lighting device	Table I Lighting device	S5.1.1.4 Alternative side reflex material.
Table I-c Lighting device	Table I Lighting device	Table III.
Table I-c Lighting device	Table I Lighting device	Table IV.
Table I-c Mounting height	Table I Mounting height	Table III.
Table I-c Mounting height	Table I Mounting height	Table IV.
Table I-c Mounting location	Table I Mounting location	Table III.
Table I-c Mounting location	Table I Mounting location	Table IV.
Table I-c Number and color	Table I Number and color	S5.1.1.10 Multiple license plate lamps and backup lamps.
Table I-c Number and color	Table I Number and color	S5.1.1.21 Motor driven cycle turn signal exemption.
Table I-c Number and color	Table I Number and color	Table III.
Table I-c Number and color	Table I Number and color	Table IV.
Table II-a Sealed beam headlamps Type A	Table II Sealed beam headlamps Type A	S7.3.2 Type A headlighting system.
Table II-a Sealed beam headlamps Type B	Table II Sealed beam headlamps Type B	S7.3.3 Type B headlighting system.
Table II-a Sealed beam headlamps Type C	Table II Sealed beam headlamps Type C	S7.3.4 Type C headlighting system.
Table II-a Sealed beam headlamps Type D	Table II Sealed beam headlamps Type D	S7.3.5 Type D headlighting system.
Table II-a Sealed beam headlamps Type E	Table II Sealed beam headlamps Type E	S7.3.6 Type E headlighting system.
Table II-a Sealed beam headlamps Type F	Table II Sealed beam headlamps Type F	S7.3.7 Type F headlighting system.
Table II-a Sealed beam headlamps Type G	Table II Sealed beam headlamps Type G	S7.3.8 Type G headlighting system.
Table II-a Sealed beam headlamps Type H	Table II Sealed beam headlamps Type H	S7.3.9 Type H headlighting system.
Table II-b Combination headlamps—2 lamp system.	Table II Combination headlamps—2 lamp system.	S7.6.2.
Table II-b Combination headlamps—4 lamp system.	Table II Combination headlamps—4 lamp system.	S7.6.3.
Table II-c Integral beam headlamps—2 lamp system.	Table II Integral beam headlamps—2 lamp system.	S7.4(a)(2).
Table II-c Integral beam headlamps—4 lamp system.	Table II Integral beam headlamps—4 lamp system.	S7.4(a)(1)(i).
Table II-c Integral beam headlamps—4 lamp system U & L.	Table II Integral beam headlamps—4 lamp system U & L.	S7.4(a)(1)(iii).
Table II-c Integral beam headlamps—4 lamp system—simultaneous activation.	Table II Integral beam headlamps—4 lamp system—simultaneous activation.	S7.4(a)(1)(ii).
Table II-c Integral beam headlamps—beam contributor system.	Table II Integral beam headlamps—beam contributor system.	S7.4(a)(3).
Table II-d Replaceable bulb headlamps—2 lamp system—with HB2.	Table II Replaceable bulb headlamps—2 lamp system—with HB2.	Figure 26.
Table II-d Replaceable bulb headlamps—2 lamp system—with HB2.	Table II Replaceable bulb headlamps—2 lamp system—with HB2.	S7.5(e).
Table II-d Replaceable bulb headlamps—2 lamp system—without HB2.	Table II Replaceable bulb headlamps—2 lamp system—without HB2.	Figure 26.
Table II-d Replaceable bulb headlamps—2 lamp system—without HB2.	Table II Replaceable bulb headlamps—2 lamp system—without HB2.	S7.5(d).
Table II-d Replaceable bulb headlamps—4 lamp system—with HB2.	Table II Replaceable bulb headlamps—4 lamp system—with HB2.	Figure 26.
Table II-d Replaceable bulb headlamps—4 lamp system—with HB2.	Table II Replaceable bulb headlamps—4 lamp system—with HB2.	S7.5(e).
Table II-d Replaceable bulb headlamps—4 lamp system—without HB2.	Table II Replaceable bulb headlamps—4 lamp system—without HB2.	Figure 26.
Table II-d Replaceable bulb headlamps—4 lamp system—without HB2.	Table II Replaceable bulb headlamps—4 lamp system—without HB2.	S7.5(d).
Table II footnote 1	Table II footnote 1	S5.5.8.
Table II footnote 2	Table II footnote 2	S7.4(d).
Table II footnote 3	Table II footnote 3	S5.5.8.
Table II footnote 4	Table II footnote 4	S5.5.8.
Table II footnote 5	Table II footnote 5	S5.5.8.
Table II footnote 6	Table II footnote 6	S7.4(a)(3).
Table II footnote 7	Omitted	S7.4(a)(3).
Table III Marking Requirements Locations [New Table—points to marking requirements].	New table	New table.
Table IV-a Front turn signal lamp—Effective projected luminous lens area.	Table IV Front turn signal lamp—Effective projected luminous lens area.	S5.1.1.25 Motor cycle turn signal lamp EPLLA.
Table IV-a Front turn signal lamp—Effective projected luminous lens area.	Table IV Front turn signal lamp—Effective projected luminous lens area.	SAE J1395, Apr 1985, 5.3.2.
Table IV-a Front turn signal lamp—Effective projected luminous lens area.	Table IV Front turn signal lamp—Effective projected luminous lens area.	SAE J588, Nov 1984, 5.3.2.
Table IV-a Rear turn signal lamp—Effective projected luminous lens area.	Table IV Rear turn signal lamp—Effective projected luminous lens area.	S5.1.1.25 Motor cycle turn signal lamp EPLLA.
Table IV-a Rear turn signal lamp—Effective projected luminous lens area.	Table IV Rear turn signal lamp—Effective projected luminous lens area.	S5.1.1.26(a).

APPENDIX B.—FMVSS NO. 108 REWRITE CROSS REFERENCE—Continued

Current FMVSS No. 108 or incorporated document citation	FMVSS No. 108 rewrite NPRM citation	FMVSS No. 108 rewrite final rule citation
Table IV—a Rear turn signal lamp—Effective projected luminous lens area.	Table IV Rear turn signal lamp—Effective projected luminous lens area.	S5.1.1.26(b).
Table IV—a Rear turn signal lamp—Effective projected luminous lens area.	Table IV Rear turn signal lamp—Effective projected luminous lens area.	SAE J1395, Apr 1985, 5.3.2.
Table IV—a Stop lamp—Effective projected luminous lens area.	Table IV Stop lamp—Effective projected luminous lens area.	S5.1.1.22 Motor driven cycle stop lamp exemptions.
Table IV—a Stop lamp—Effective projected luminous lens area.	Table IV Stop lamp—Effective projected luminous lens area.	S5.1.1.26(a).
Table IV—a Stop lamp—Effective projected luminous lens area.	Table IV Stop lamp—Effective projected luminous lens area.	S5.1.1.26(b).
Table IV—a Stop lamp—Effective projected luminous lens area.	Table IV Stop lamp—Effective projected luminous lens area.	SAE J1398, May 1985, 5.3.2.
Table IV—b High mounted stop lamp—Effective projected luminous lens area.	Table IV High mounted stop lamp—Effective projected luminous lens area.	S5.1.1.27(a)(1).
Table IV—b High mounted stop lamp—Effective projected luminous lens area.	Table IV High mounted stop lamp—Effective projected luminous lens area.	S5.1.1.27(b)(1).
Table IV—c School bus signal lamp—Effective projected luminous lens area.	Table IV School bus signal lamp—Effective projected luminous lens area.	SAE J887, Jul 1964.
Table IV footnote 1	Table IV footnote 1	S5.1.1.22 Motor driven cycle stop lamp exemptions.
Table V—a Backup lamp visibility	Table V Backup lamp visibility	S5.3.2(e).
Table V—a High mounted stop lamp visibility	Table V High mounted stop lamp visibility	S5.3.2(c).
Table V—a High mounted stop lamp visibility	Table V High mounted stop lamp visibility	S5.3.2(d).
Table V—a HMSL—Visibility	Table V HMSL—Visibility	S5.1.1.27(a)(2).
Table V—a HMSL—Visibility	Table V HMSL—Visibility	S5.1.1.27(b)(2).
Table V—a School bus signal lamp visibility	Table V School bus signal lamp visibility	SAE J887, Jul 1964.
Table V—b SAE stop lamp visibility	Table V SAE stop lamp visibility	SAE J1398, May 1985, 5.4.1.
Table V—b SAE stop lamp visibility	Table V SAE stop lamp visibility	SAE J586, Feb 1984, 5.4.1.
Table V—b SAE taillamp visibility	Table V SAE taillamp visibility	SAE J585e, Sep 1977, 4.
Table V—b SAE turn signal lamp visibility	Table V SAE turn signal lamp visibility	SAE J1395, Apr 1985, 5.4.1.
Table V—b SAE turn signal lamp visibility	Table V SAE turn signal lamp visibility	SAE J588, Nov 1984, 5.4.1.
Table V—c Lens area visibility	Table V Lens area visibility	Figure 19.
Table V—c Lens area visibility	Table V Lens area visibility	S5.3.2(b)(1).
Table V—d Luminous intensity visibility	Table V Luminous intensity visibility	Figure 20.
Table V—d Luminous intensity visibility	Table V Luminous intensity visibility	S5.3.2(b)(2).
Table V footnote 1	Table V footnote 1	New language.
Table V footnote 2	Table V footnote 2	S5.3.2.3.
Table V footnote 3	Table V footnote 3	Figure 19, footnote 2.
Table V footnote 4	Table V footnote 4	Figure 20, footnote 2.
Table VI—a Front turn signal lamp—Base group photometry.	Table VI Front turn signal lamp—Base zone photometry.	SAE J1395, Apr 1985, Table 1.
Table VI—a Front turn signal lamp—Base group photometry.	Table VI Front turn signal lamp—Base zone photometry.	SAE J588, Nov 1984, Table 1.
Table VI—a Front turn signal lamp—Base individual point photometry.	Table VI Front turn signal lamp—Base individual point photometry.	SAE J1395, Apr 1985, Table 3.
Table VI—a Front turn signal lamp—Base individual point photometry.	Table VI Front turn signal lamp—Base individual point photometry.	SAE J588, Nov 1984, Table 3.
Table VI—b Front turn signal lamp—1.5 × base group photometry.	Table VI Front turn signal lamp—1.5 × base zone photometry.	SAE J1395, Apr 1985, 5.1.5.4.
Table VI—b Front turn signal lamp—1.5 × base group photometry.	Table VI Front turn signal lamp—1.5 × base zone photometry.	SAE J1395, Apr 1985, Table 2.
Table VI—b Front turn signal lamp—1.5 × base group photometry.	Table VI Front turn signal lamp—1.5 × base zone photometry.	SAE J588, Nov 1984, 5.1.5.4.
Table VI—b Front turn signal lamp—1.5 × base group photometry.	Table VI Front turn signal lamp—1.5 × base zone photometry.	SAE J588, Nov 1984, Table 2.
Table VI—b Front turn signal lamp—1.5 × base individual point photometry.	Table VI Front turn signal lamp—1.5 × base individual point photometry.	SAE J1395, Apr 1985, 5.1.5.4.
Table VI—b Front turn signal lamp—1.5 × base individual point photometry.	Table VI Front turn signal lamp—1.5 × base individual point photometry.	SAE J1395, Apr 1985, Table 2.
Table VI—b Front turn signal lamp—1.5 × base individual point photometry.	Table VI Front turn signal lamp—1.5 × base individual point photometry.	SAE J588, Nov 1984, 5.1.5.4.
Table VI—b Front turn signal lamp—1.5 × base individual point photometry.	Table VI Front turn signal lamp—1.5 × base individual point photometry.	SAE J588, Nov 1984, Table 2.
Table VI—b Front turn signal lamp—2 × base group photometry.	Table VI Front turn signal lamp—2 × base zone photometry.	SAE J1395, Apr 1985, 5.1.5.4.
Table VI—b Front turn signal lamp—2 × base group photometry.	Table VI Front turn signal lamp—2 × base zone photometry.	SAE J1395, Apr 1985, Table 2.
Table VI—b Front turn signal lamp—2 × base group photometry.	Table VI Front turn signal lamp—2 × base zone photometry.	SAE J588, Nov 1984, 5.1.5.4.
Table VI—b Front turn signal lamp—2 × base group photometry.	Table VI Front turn signal lamp—2 × base zone photometry.	SAE J588, Nov 1984, Table 2.

APPENDIX B.—FMVSS NO. 108 REWRITE CROSS REFERENCE—Continued

Current FMVSS No. 108 or incorporated document citation	FMVSS No. 108 rewrite NPRM citation	FMVSS No. 108 rewrite final rule citation
Table VI—b Front turn signal lamp—2 × base individual point photometry.	Table VI Front turn signal lamp—2 × base individual point photometry.	SAE J1395, Apr 1985, 5.1.5.4.
Table VI—b Front turn signal lamp—2 × base individual point photometry.	Table VI Front turn signal lamp—2 × base individual point photometry.	SAE J1395, Apr 1985, Table 2.
Table VI—b Front turn signal lamp—2 × base individual point photometry.	Table VI Front turn signal lamp—2 × base individual point photometry.	SAE J588, Nov 1984, 5.1.5.4.
Table VI—b Front turn signal lamp—2 × base individual point photometry.	Table VI Front turn signal lamp—2 × base individual point photometry.	SAE J588, Nov 1984, Table 2.
Table VI—a Front turn signal lamp—2.5 × base group photometry.	Table VI Front turn signal lamp—2.5 × base zone photometry.	S5.3.1.7 Turn signal spacing.
Table VI—a Front turn signal lamp—2.5 × base group photometry.	Table VI Front turn signal lamp—2.5 × base zone photometry.	SAE J1395, Apr 1985, 5.1.5.4.
Table VI—a Front turn signal lamp—2.5 × base group photometry.	Table VI Front turn signal lamp—2.5 × base zone photometry.	SAE J1395, Apr 1985, Table 2.
Table VI—a Front turn signal lamp—2.5 × base group photometry.	Table VI Front turn signal lamp—2.5 × base zone photometry.	SAE J588, Nov 1984, 5.1.5.4.
Table VI—a Front turn signal lamp—2.5 × base group photometry.	Table VI Front turn signal lamp—2.5 × base zone photometry.	SAE J588, Nov 1984, Table 2.
Table VI—a Front turn signal lamp—2.5 × base individual point photometry.	Table VI Front turn signal lamp—2.5 × base individual point photometry.	S5.3.1.7 Turn signal spacing.
Table VI—a Front turn signal lamp—2.5 × base individual point photometry.	Table VI Front turn signal lamp—2.5 × base individual point photometry.	SAE J1395, Apr 1985, 5.1.5.4.
Table VI—a Front turn signal lamp—2.5 × base individual point photometry.	Table VI Front turn signal lamp—2.5 × base individual point photometry.	SAE J1395, Apr 1985, Table 2.
Table VI—a Front turn signal lamp—2.5 × base individual point photometry.	Table VI Front turn signal lamp—2.5 × base individual point photometry.	SAE J588, Nov 1984, 5.1.5.4.
Table VI—a Front turn signal lamp—2.5 × base individual point photometry.	Table VI Front turn signal lamp—2.5 × base individual point photometry.	SAE J588, Nov 1984, Table 2.
Table VI Front turn signal lamp—Photometric ratio.	Table VI Front turn signal lamp—Photometric ratio.	SAE J1395, Apr 1985, 5.1.5.2.
Table VI Front turn signal lamp—Photometric ratio.	Table VI Front turn signal lamp—Photometric ratio.	SAE J588, Nov 1984, 5.1.5.3.
Table VI footnote 1	Table VI footnote 1	SAE J588, Nov 1984, Table 1, footnote a; SAE J1395, Apr 1985, footnote a.
Table VI footnote 2	Table VI footnote 2	SAE J575e, Aug 1970, J.
Table VI footnote 3	Table VI footnote 3	S5.3.2.3.
Table VI footnote 4	Table VI footnote 4	SAE J1395, Apr 1985, 5.1.5.2.
Table VII Rear turn signal lamp—Red lamp individual point photometry.	Table VII Rear turn signal lamp—Red lamp individual point photometry.	SAE J1395, Apr 1985, Table 3.
Table VII Rear turn signal lamp—Red lamp individual point photometry.	Table VII Rear turn signal lamp—Red lamp individual point photometry.	SAE J588, Nov 1984, Table 3.
Table VII Rear turn signal lamp—Red lamp group photometry.	Table VII Rear turn signal lamp—Red lamp zone photometry.	SAE J1395, Apr 1985, Table 1.
Table VII Rear turn signal lamp—Red lamp group photometry.	Table VII Rear turn signal lamp—Red lamp zone photometry.	SAE J588, Nov 1984, Table 1.
Table VII Rear turn signal lamp—Amber lamp individual point photometry.	Table VII Rear turn signal lamp—Amber lamp individual point photometry.	SAE J1395, Apr 1985, Table 3.
Table VII Rear turn signal lamp—Amber lamp individual point photometry.	Table VII Rear turn signal lamp—Amber lamp individual point photometry.	SAE J588, Nov 1984, Table 3.
Table VII Rear turn signal lamp—Amber lamp group photometry.	Table VII Rear turn signal lamp—Amber lamp zone photometry.	SAE J1395, Apr 1985, Table 1.
Table VII Rear turn signal lamp—Amber lamp group photometry.	Table VII Rear turn signal lamp—Amber lamp zone photometry.	SAE J588, Nov 1984, Table 1.
Table VII Rear turn signal lamp—Photometric ratio.	Table VII Rear turn signal lamp—Photometric ratio.	SAE J1395, Apr 1985, 5.1.5.2.
Table VII Rear turn signal lamp—Photometric ratio.	Table VII Rear turn signal lamp—Photometric ratio.	SAE J588, Nov 1984, 5.1.5.3.
Table VII footnote 1	Table VII footnote 1	SAE J588, Nov 1984, Table 1, footnote a; SAE J1395, Apr 1985 footnote a.
Table VII footnote 2	Table VII footnote 2	SAE J575e, Aug 1970, J.
Table VII footnote 3	Table VII footnote 3	S5.3.2.3.
Table VII footnote 4	Table VII footnote 4	SAE J588, Nov 1984, Table 1, footnote b; SAE J1395, Apr 1985 footnote b.
Table VII footnote 5	Table VII footnote 5	SAE J588, Nov 1984, Table 1; SAE J1395, Apr 1985, Table 1.
Table VII footnote 6	Table VII footnote 6	S5.1.1.1; SAE J588e, Sep 1970, 3.9.1; SAE J1395, Apr 1985, 5.1.5.3.
Table VII footnote 7	Table VII footnote 7	SAE J1395, Apr 1985, 5.1.5.2.
Table VII footnote 8	Table VII footnote 8	SAE J588, Nov 1984, 5.1.5.3; SAE J1395, Apr 1985, 5.1.5.2.

APPENDIX B.—FMVSS NO. 108 REWRITE CROSS REFERENCE—Continued

Current FMVSS No. 108 or incorporated document citation	FMVSS No. 108 rewrite NPRM citation	FMVSS No. 108 rewrite final rule citation
Table VIII Taillamp—Individual point photometry.	Table VIII Taillamp—Individual point photometry.	Figure 1a.
Table VIII Taillamp—Individual point photometry.	Table VIII Taillamp—Individual point photometry.	Figure 1b.
Table VIII Taillamp—Individual point photometry.	Table VIII Taillamp—Individual point photometry.	Figure 1c.
Table VIII Taillamp—Group photometry	Table VIII Taillamp—Zone photometry	Figure 1a.
Table VIII Taillamp—Group photometry	Table VIII Taillamp—Zone photometry	Figure 1b.
Table VIII Taillamp—Group photometry	Table VIII Taillamp—Zone photometry	Figure 1c.
Table VIII Taillamp—Maximum photometric intensity.	Table VIII Taillamp—Maximum photometric intensity.	Figure 1b, footnote 1.
Table VIII footnote 1	Table VIII footnote 1	SAE J575e, Aug 1970, J.
Table VIII footnote 2	Table VIII footnote 2	S5.1.1.6.
Table VIII footnote 3	Table VIII footnote 3	S5.3.2.3.
Table VIII footnote 4	Omitted	SAE J585e, Sep 1977, Table 1, footnote 5.
Table IX Stop lamp—Individual point photometry.	Table IX Stop lamp—Individual point photometry.	SAE J1398, May 1985, Table 1.
Table IX Stop lamp—Individual point photometry.	Table IX Stop lamp—Individual point photometry.	SAE J586, Feb 1984, Table 1.
Table IX Stop lamp—Group photometry	Table IX Stop lamp—Zone photometry	SAE J1398, May 1985, Table 1.
Table IX Stop lamp—Group photometry	Table IX Stop lamp—Zone photometry	SAE J586, Feb 1984, Table 1.
Table IX Stop lamp—Photometric ratio	Table IX Stop lamp—Photometric ratio	SAE J1398, May 1985, 5.1.5.2.
Table IX Stop lamp—Photometric ratio	Table IX Stop lamp—Photometric ratio	SAE J586, Feb 1984, 5.1.5.3.
Table IX footnote 1	Table IX footnote 1	SAE J586, Feb 1984, Table 1, footnote a; SAE J1398, May 1985, footnote a.
Table IX footnote 2	Table IX footnote 2	SAE J575e, Aug 1970, J.
Table IX footnote 3	Table IX footnote 3	SAE J586, Feb 1984, Table 1, footnote b; SAE J1398, May 1985, footnote b.
Table IX footnote 4	Table IX footnote 4	S5.3.2.3.
Table IX footnote 5	Table IX footnote 7	SAE J586, Feb 1984, 5.1.5.3; SAE J1398, May 1985, 5.1.5.2.
Table IX footnote 6	Table IX footnote 6	SAE J586, Feb 1984, 5.1.5.3; SAE J1398, May 1985, 5.1.5.2.
Table X Red side marker lamp photometry	Table X Red side marker lamp photometry	SAE J592e, Jul 1972, Table 1.
Table X Amber side marker lamp photometry ..	Table X Amber side marker lamp photometry ..	SAE J592e, Jul 1972, Table 1.
Table X footnote 1	Table X footnote 1	S5.1.1.8; SAE J592e, Jul 1972, Table 1, footnote b.
Table X footnote 2	Table X footnote 2	SAE J575d, Aug 1967, J.
Table X footnote 3	Table X footnote 3	S5.3.2.3.
Table XI Red clearance and identification lamp photometry.	Table XI Red clearance and identification lamp photometry.	SAE J592e, Jul 1972, Table 1.
Table XI Amber clearance and identification lamp photometry.	Table XI Amber clearance and identification lamp photometry.	SAE J592e, Jul 1972, Table 1.
Table XI footnote 1	Table XI footnote 1	S5.3.2.3.
Table XI footnote 2	Table XI footnote 2	SAE J575d, Aug 1967, J.
Table XI footnote 3	Table XI footnote 3	SAE J592e, Jul 1972, Table 1, footnote a.
Table XI footnote 4	Table XI footnote 4	S5.3.2.1.
Table XII Single lamp system—Individual point photometry.	Table XII Single backup lamp system—Individual point photometry.	S5.1.1.18 Backup lamp photometry.
Table XII Single lamp system—Individual point photometry.	Table XII Single backup lamp system—Individual point photometry.	SAE J593c, Feb 1968, Table 1, footnote a.
Table XII Single lamp system—Group photometry.	Table XII Single backup lamp system—Zone photometry.	Figure 2, footnote 1.
Table XII Two lamp systems—Each lamp—Individual point photometry.	Table XII Two backup lamp system—Individual point photometry.	S5.1.1.18 Backup lamp photometry.
Table XII Two lamp systems—Each lamp—Individual point photometry.	Table XII Two backup lamp system—Individual point photometry.	SAE J593c, Feb 1968, Table 1, footnote b.
Table XII Two lamp system—Each lamp—Group photometry.	Table XII Two backup lamp system—Zone photometry.	Figure 2, footnote 1.
Table XII Backup lamp—Maximum photometric intensity any single lamp.	Table XII Backup lamp—Maximum photometric intensity.	SAE J593c, Feb 1968, Table 1, footnote c.
Table XII footnote 1	Table XII footnote 1	SAE J575d, Aug 1967, J.
Table XII footnote 2	Table XII footnote 2	Figure 2, footnote 1.
Table XII footnote 3	Table XII footnote 3	Figure 2, footnote 1.
Table XII footnote 4	Table XII footnote 4	S5.1.1.18 Backup lamp photometry.
Table XIII—a Motorcycle turn signal lamp—Individual point photometry.	S7.1.1.1; S7.1.2.1	S5.1.1.7 Motorcycle turn signal lamp.
Table XIII—a Motorcycle turn signal lamp—Group photometry.	S7.1.1.1; S7.1.2.1	S5.1.1.7 Motorcycle turn signal lamp.
Table XIII—a Motorcycle turn signal lamp—Photometric ratio.	S7.1.1.1; S7.1.2.1	S5.1.1.7 Motorcycle turn signal lamp.

APPENDIX B.—FMVSS NO. 108 REWRITE CROSS REFERENCE—Continued

Current FMVSS No. 108 or incorporated document citation	FMVSS No. 108 rewrite NPRM citation	FMVSS No. 108 rewrite final rule citation
Table XIII–b Motorcycle stop lamp—Photometric ratio.	Table IX Stop lamp—Photometric ratio	SAE J586, Feb 1984, 5.1.5.3.
Table XIII–b Motor driven cycle stop lamp—Group photometry.	Table IX Motor driven cycle stop lamp zone photometry.	S5.1.1.22 Motor driven cycle stop lamp exemptions.
Table XIII–a footnote 1	Standard note—new table	SAE J586, Feb 1984, Table 1, footnote a; SAE J588, Nov 1984, Table 1 footnote a.
Table XIII–a footnote 2	Standard note—new table	SAE J575e, Aug 1970, J.
Table XIII–a footnote 3, Table XIII footnote 1 ...	Standard note—new table	SAE J586, Feb 1984, Table 1, footnote b.
Table XIII–a footnote 4, Table XIII–b footnote 2	Standard note—new table	S5.3.2.3.
Table XIII–b footnote 3	Table IX footnote 5	S5.1.1.22; Interpretation—Parkyn 6/1/98.
Table XIII–a footnote 5, Table XIII–b footnote 4	Table IX footnote 7	SAE J586, Feb 1984, 5.1.5.3.
Table XIV Parking lamp—Individual point photometry.	Table XIV Parking lamp—Individual point photometry.	Figures 1a, 1b, and 1c.
Table XIV Parking lamp—Group photometry	Table XIV Parking lamp—Zone photometry	Figures 1a, 1b, and 1c.
Table XIV Parking lamp—Maximum photometric intensity.	Table XIV Parking lamp—Maximum photometric intensity.	Figure 1b, footnote 2.
Table XIV footnote 1	Table XIV footnote 1	SAE J575d, Aug 1967, J.
Table XIV footnote 2	Table XIV footnote 2	S5.1.1.6.
Table XIV footnote 3	Table XIV footnote 3	S5.3.2.3.
Table XV High mounted stop lamp—Individual point photometry.	Table XV High mounted stop lamp—Individual point photometry.	Figure 10.
Table XV High mounted stop lamp—Group photometry.	Table XV High mounted stop lamp—Zone photometry.	Figure 10.
Table XV footnote 1	Table XV footnote 1	SAE J575e, Aug 1970, J.
Table XV footnote 2	Table XV footnote 2	Figure 10, footnote 2.
Table XV footnote 3	Table XV footnote 3	S5.1.1.27(b)(3).
Table XV footnote 4	Table XV footnote 4	Figure 10, footnote 1.
Table XVI–a Red reflex reflector photometry	Table XVI Red reflex reflector photometry	SAE J594f, Jan 1977, Tables 1 and 1A.
Table XVI–a Amber reflex reflector photometry	Table XVI Amber reflex reflector photometry ..	SAE J594f, Jan 1977, Table 1, footnote a.
Table XVI–a Amber reflex reflector photometry	Table XVI Amber reflex reflector photometry ..	SAE J594f, Jan 1977, Table 1A, footnote a.
Table XVI–a White reflex reflector photometry	Table XVI White reflex reflector photometry	SAE J594f, Jan 1977, Table 1, footnote a.
Table XVI–a White reflex reflector photometry	Table XVI White reflex reflector photometry	SAE J594f, Jan 1977, Table 1A, footnote a
Table XVI–a footnote 1	Table XVI footnote 1	S5.3.2.3.
Table XVI–b Red conspicuity reflex reflector photometry.	Table XVI Red conspicuity reflex reflector photometry.	S5.7.2.1(b).
Table XVI–b White horizontal conspicuity reflex reflector photometry.	Table XVI White horizontal conspicuity reflex reflector photometry.	S5.7.2.1(c).
Table XVI–b White vertical conspicuity reflex reflector photometry.	Table XVI White vertical conspicuity reflex reflector photometry.	S5.7.2.1(d).
Table XVI–c Red C2 sheeting photometry	Table XVI Red C2 sheeting photometry	S5.7.1.2; Figure 29.
Table XVI–c Red C3 sheeting photometry	Table XVI Red C3 sheeting photometry	S5.7.1.2; Figure 29.
Table XVI–c Red C4 sheeting photometry	Table XVI Red C4 sheeting photometry	S5.7.1.2; Figure 29.
Table XVI–c White C2 sheeting photometry	Table XVI White C2 sheeting photometry	S5.7.1.2; Figure 29.
Table XVI–c White C3 sheeting photometry	Table XVI White C3 sheeting photometry	S5.7.1.2; Figure 29.
Table XVI–c White C4 sheeting photometry	Table XVI White C4 sheeting photometry	S5.7.1.2; Figure 29.
Table XVII School bus signal lamp photometry	Table XVII School bus signal lamp photometry	SAE J887, Jul 1964, Table 1.
Table XVII Red lamp photometry	Table XVII Red lamp photometry	SAE J575d, Aug 1967, J.
Table XVII Amber lamp photometry	Table XVII Amber lamp photometry	S5.1.4(b).
Table XVII footnote 1	Table XVII footnote 1	S5.3.2.3.
Table XVII footnote 2	Table XVII footnote 2	SAE J575d, Aug 1967, J.
Table XVIII Upper beam #1 photometry	Table XVIII Upper beam #1 photometry	Figure 15–1.
Table XVIII Upper beam #1 photometry	Table XVIII Upper beam #1 photometry	Figure 15–2.
Table XVIII Upper beam #2 photometry	Table XVIII Upper beam #2 photometry	Figure 17–1.
Table XVIII Upper beam #2 photometry	Table XVIII Upper beam #2 photometry	Figure 17–2.
Table XVIII Upper beam #3 photometry	Table XVIII Upper beam #3 photometry	Figure 27–1.
Table XVIII Upper beam #3 photometry	Table XVIII Upper beam #3 photometry	Figure 27–2.
Table XVIII Upper beam #4 photometry	Table XVIII Upper beam #4 photometry	Figure 28–1, Types 1A1, 1C1, and 1G1.
Table XVIII Upper beam #4 photometry	Table XVIII Upper beam #4 photometry	Figure 28–2, Types 1A1, 1C1, and 1G1.
Table XVIII Upper beam #5 photometry	Table XVIII Upper beam #5 photometry	Figure 28–1, Types 2A1, 2C1, and 2G1.
Table XVIII Upper beam #5 photometry	Table XVIII Upper beam #5 photometry	Figure 28–2, Types 2A1, 2C1, and 2G1.
Table XVIII Upper beam #6 photometry	Table XVIII Upper beam #6 photometry	Figure 15–1.
Table XVIII Upper beam #6 photometry	Table XVIII Upper beam #6 photometry	Figure 15–2.
Table XVIII Upper beam #6 photometry	Table XVIII Upper beam #6 photometry	S7.4(a)(1)(ii).
Table XIX–a Lower beam #1M photometry	Table XIX Lower beam #1M photometry	Figure 15–1.
Table XIX–a Lower beam #1V photometry	Table XIX Lower beam #1V photometry	Figure 15–2.
Table XIX–a Lower beam #2M photometry	Table XIX Lower beam #2M photometry	Figure 17–1.
Table XIX–a Lower beam #2V photometry	Table XIX Lower beam #2V photometry	Figure 17–2.
Table XIX–a Lower beam #2V photometry	Table XIX Lower beam #2V photometry	Figure 28–2, Types 2A1, 2C1 and 2G1.
Table XIX–b Lower beam #3M photometry	Table XIX Lower beam #3M photometry	Figure 27–1.
Table XIX–b Lower beam #3V photometry	Table XIX Lower beam #3V photometry	Figure 27–2.
Table XIX–b Lower beam #4M photometry	Table XIX Lower beam #4M photometry	Figure 28–2, Types 2A1, 2C1, and 2G1.

APPENDIX B.—FMVSS NO. 108 REWRITE CROSS REFERENCE—Continued

Current FMVSS No. 108 or incorporated document citation	FMVSS No. 108 rewrite NPRM citation	FMVSS No. 108 rewrite final rule citation
Table XIX–c Lower beam #4V photometry	Table XIX Lower beam #4V photometry	Figure 15–2.
Table XIX–c Lower beam #4V photometry	Table XIX Lower beam #4V photometry	S7.4(a)(1)(ii).
Table XIX–b Lower beam #5M photometry	Table XIX Lower beam #5M photometry	Figure 15–1.
Table XIX–b Lower beam #5M photometry	Table XIX Lower beam #5M photometry	S7.4(a)(1)(ii).
Table XIX 10° U–90° U Test area	Table XIX 10° U–90° U Test area	Interpretation—Spingler 7/2/99.
Table XX Motorcycle photometry	Table XX Motorcycle photometry	Figure 32.
Table XX Motor driven cycle photometry	Table XX Motor driven cycle photometry	Figure 32.
Table XX Motor driven cycle with single lamp photometry.	Table XX Motor driven cycle with single lamp photometry.	Figure 32.
Redundant—eliminated	S8.1.1 Headlighting system type	S7.3.
Redundant—eliminated	S8.1.1 Headlighting system type	S7.4.
Redundant—eliminated	S8.1.1 Headlighting system type	S7.5.
Redundant—eliminated	S8.1.1 Headlighting system type	S7.6.
Redundant—eliminated	S8.1.2 Headlamp category	S7.3.
Redundant—eliminated	S8.1.2 Headlamp category	S7.4.
Redundant—eliminated	S8.1.2 Headlamp category	S7.5.
Redundant—eliminated	S8.1.2 Headlamp category	S7.6.
Relocated to Part 564, Appendix C	Relocated to Part 564, Appendix C	Figure 11.
Relocated to Part 564, Appendix C	Relocated to Part 564, Appendix C	Figure 12.
Relocated to Part 564, Appendix C	Relocated to Part 564, Appendix C	Figure 13.
Relocated to Part 564, Appendix C	Relocated to Part 564, Appendix C	Figure 14.
Relocated to Part 564, Appendix C	Relocated to Part 564, Appendix C	Figure 18.
Relocated to Part 564, Appendix C	Relocated to Part 564, Appendix C	Figure 21.
Relocated to Part 564, Appendix C	Relocated to Part 564, Appendix C	SAE J1383, Apr 1985, 5.3.
Relocated to Part 564, Appendix C	Relocated to Part 564, Appendix C	SAE J1383, Apr 1985, Figure 10.
Relocated to Part 564, Appendix C	Relocated to Part 564, Appendix C	SAE J1383, Apr 1985, Figure 11.
Relocated to Part 564, Appendix C	Relocated to Part 564, Appendix C	SAE J1383, Apr 1985, Figure 11.
Relocated to Part 564, Appendix C	Relocated to Part 564, Appendix C	SAE J1383, Apr 1985, Figure 12.
Relocated to Part 564, Appendix C	Relocated to Part 564, Appendix C	SAE J1383, Apr 1985, Figure 13.
Relocated to Part 564, Appendix C	Relocated to Part 564, Appendix C	SAE J1383, Apr 1985, Figure 14.
Relocated to Part 564, Appendix C	Relocated to Part 564, Appendix C	SAE J1383, Apr 1985, Figure 15.
Relocated to Part 564, Appendix C	Relocated to Part 564, Appendix C	SAE J1383, Apr 1985, Figure 5.
Relocated to Part 564, Appendix C	Relocated to Part 564, Appendix C	SAE J1383, Apr 1985, Figure 6.
Relocated to Part 564, Appendix C	Relocated to Part 564, Appendix C	SAE J1383, Apr 1985, Figure 7.
Relocated to Part 564, Appendix C	Relocated to Part 564, Appendix C	SAE J1383, Apr 1985, Figure 8.
Relocated to Part 564, Appendix C	Relocated to Part 564, Appendix C	SAE J1383, Apr 1985, Figure 9.

APPENDIX C.—LIST OF FIGURES

[Current FMVSS No. 108 is 49 CFR 571.108, Oct. 1, 2006]

Figure No.	Title
1	CHROMATICITY DIAGRAM [SAE J578c, FEB 1977, FIGURE 1].
2	FLASHER PERFORMANCE CHART [SAE J590b, OCT 1965, FIGURE 1].
3	REPLACEABLE BULB HEADLAMP AIM PADS [CURRENT FMVSS 108 FIG. 4–1 TO 4–4].
4	HEADLAMP CONNECTOR TEST SETUP [SAE J580, DEC 1986, FIGURE 1].
5	HEADLAMP ABRASION TEST FIXTURE [CURRENT FMVSS 108 FIGURE 5].
6	THERMAL CYCLE TEST PROFILE [CURRENT FMVSS 108 FIGURE 6].
7	DIRT/AMBIENT TEST SETUP [CURRENT FMVSS108 FIGURE 7].
8	REPLACEABLE LIGHT SOURCE DEFLECTION TEST SETUP [CURRENT FMVSS 108 FIGURE 8].
9	ENVIRONMENTAL TEST PROFILE [CURRENT FMVSS108 FIGURE 9].
10	REPLACEABLE LIGHT SOURCE PRESSURE TEST SETUP [CURRENT FMVSS108 FIGURE 25].
11	TRAILER CONSPICUITY TREATMENT EXAMPLES [CURRENT FMVSS108 FIGURES 30–1 TO 30–4].
12–1	TRAILER CONSPICUITY DETAIL I [NEW].
12–2	TRAILER CONSPICUITY DETAIL II [NEW].
13	TRACTOR CONSPICUITY TREATMENT EXAMPLES [CURRENT FMVSS108 FIGURE 31].
14	92 x 150 HEADLAMP AIM DEFLECTION TEST SETUP [CURRENT FMVSS108 FIGURE 16].
15	TYPES G AND H HEADLAMP AIM DEFLECTION TEST SETUP [CURRENT FMVSS108 FIGURE 22].
16	TYPES A AND E HEADLAMP AIM DEFLECTION TEST SETUP [SAE J580, DEC 1986, FIGURE 3].
17	TYPE B HEADLAMP AIM DEFLECTION TEST SETUP [SAE J580, DEC 1986, FIGURE 4].
18	TYPES C AND D HEADLAMP AIM DEFLECTION TEST SETUP [SAE J580, DEC 1986, FIGURE 2].
19	LICENSE PLATE LAMP TARGET LOCATIONS [SAE J587, OCT 1981, FIGURES 1 & 2].
20	LICENSE PLATE LAMP MEASUREMENT OF INCIDENT LIGHT ANGLE [SAE J587, OCT 1981, FIGURE 3].
21	VIBRATION TEST MACHINE [SAE J577, APRIL 1964, FIGURE 1 & TABLE 1].
22	FLASHER STANDARD TEST CIRCUIT [SAE J823b, APRIL 1968, FIGURE 1].

APPENDIX C.—LIST OF FIGURES—Continued
 [Current FMVSS No. 108 is 49 CFR 571.108, Oct. 1, 2006]

Figure No.	Title
FIGURES TO INCORPORATE IN 49 CFR 564 APPENDIX C	
	LF HEADLAMP DIMENSIONAL INFORMATION [CURRENT FMVSS108 FIGURE 11] [INCLUDES TYPE F NONADJUSTABLE HEADLAMP AIMING DEVICE LOCATING PLATE INFORMATION].
	UF HEADLAMP DIMENSIONAL INFORMATION [CURRENT FMVSS108 FIGURE 12].
	LF/UF MOUNTING FEATURES [CURRENT FMVSS108 FIGURE 13].
	LF/UF MOUNTING RING [CURRENT FMVSS108 FIGURE 14].
	TYPE G & H HEADLAMP DIMENSIONAL INFORMATION [CURRENT FMVSS 108 FIGURE 18].
	TYPE G & H HEADLAMP MOUNTING INFORMATION [CURRENT FMVSS108 FIGURE 21].
	TYPE 1A1 HEADLAMP DIMENSIONAL INFORMATION [SAE J1383, APR 1985, FIGURE 11].
	TYPE 2A1 HEADLAMP DIMENSIONAL INFORMATION [SAE J1383, APR 1985, FIGURE 10] [INCLUDES 100 mm X 165 mm NONADJUSTABLE HEADLAMP AIMING DEVICE LOCATING PLATE INFORMATION].
	TYPE 2B1 HEADLAMP DIMENSIONAL INFORMATION [SAE J1383, APR 1985, FIGURE 13] [INCLUDES 142 mm X 200 mm NONADJUSTABLE HEADLAMP AIMING DEVICE LOCATING PLATE INFORMATION].
	TYPE 1C1 HEADLAMP DIMENSIONAL INFORMATION [SAE J1383, APR 1985, FIGURE 7] [INCLUDES 178 mm DIA. NONADJUSTABLE HEADLAMP AIMING DEVICE LOCATING PLATE INFORMATION].
	TYPE 2C1 HEADLAMP DIMENSIONAL INFORMATION [SAE J1383, APR 1985, FIGURE 8].
	TYPE 2D1 HEADLAMP DIMENSIONAL INFORMATION [SAE J1383, APR 1985, FIGURE 5] [INCLUDES 146 mm DIA. NONADJUSTABLE HEADLAMP AIMING DEVICE LOCATING PLATE INFORMATION].
	TYPE 2E1 HEADLAMP DIMENSIONAL INFORMATION [SAE J1383, APR 1985, FIGURE 15].
	TYPES 1A1, 2A1, AND 2E1 HEADLAMP MOUNTING RING/LAMP BODY DIMENSIONAL INFORMATION [SAE J1383, APR 1985, FIGURE 12].
	TYPE 2B1 HEADLAMP MOUNTING RING/LAMP BODY DIMENSIONAL INFORMATION [SAE J1383, APR 1985, FIGURE 14].
	TYPES 1C1 AND 2C1 HEADLAMP MOUNTING RING/LAMP BODY DIMENSIONAL INFORMATION [SAE J1383, APR 1985, FIGURE 9].
	TYPE 2D1 HEADLAMP MOUNTING RING/LAMP BODY DIMENSIONAL INFORMATION [SAE J1383, APR 1985, FIGURE 6].

[FR Doc. 07-5644 Filed 12-3-07; 8:45 am]

BILLING CODE 4910-59-P