



FEDERAL REGISTER

Vol. 89

Friday,

No. 47

March 8, 2024

Pages 16683–17264

OFFICE OF THE FEDERAL REGISTER



The **FEDERAL REGISTER** (ISSN 0097-6326) is published daily, Monday through Friday, except official holidays, by the Office of the Federal Register, National Archives and Records Administration, under the Federal Register Act (44 U.S.C. Ch. 15) and the regulations of the Administrative Committee of the Federal Register (1 CFR Ch. I). The Superintendent of Documents, U.S. Government Publishing Office, is the exclusive distributor of the official edition. Periodicals postage is paid at Washington, DC.

The **FEDERAL REGISTER** provides a uniform system for making available to the public regulations and legal notices issued by Federal agencies. These include Presidential proclamations and Executive Orders, Federal agency documents having general applicability and legal effect, documents required to be published by act of Congress, and other Federal agency documents of public interest.

Documents are on file for public inspection in the Office of the Federal Register the day before they are published, unless the issuing agency requests earlier filing. For a list of documents currently on file for public inspection, see www.federalregister.gov.

The seal of the National Archives and Records Administration authenticates the **Federal Register** as the official serial publication established under the Federal Register Act. Under 44 U.S.C. 1507, the contents of the **Federal Register** shall be judicially noticed.

The **Federal Register** is published in paper and on 24x microfiche. It is also available online at no charge at www.govinfo.gov, a service of the U.S. Government Publishing Office.

The online edition of the **Federal Register** is issued under the authority of the Administrative Committee of the Federal Register as the official legal equivalent of the paper and microfiche editions (44 U.S.C. 4101 and 1 CFR 5.10). It is updated by 6:00 a.m. each day the **Federal Register** is published and includes both text and graphics from Volume 1, 1 (March 14, 1936) forward. For more information, contact the GPO Customer Contact Center, U.S. Government Publishing Office. Phone 202-512-1800 or 866-512-1800 (toll free). E-mail, gpocusthelp.com.

The annual subscription price for the **Federal Register** paper edition is \$860 plus postage, or \$929, for a combined **Federal Register**, **Federal Register** Index and List of CFR Sections Affected (LSA) subscription; the microfiche edition of the **Federal Register** including the **Federal Register** Index and LSA is \$330, plus postage. Six month subscriptions are available for one-half the annual rate. The prevailing postal rates will be applied to orders according to the delivery method requested. The price of a single copy of the daily **Federal Register**, including postage, is based on the number of pages: \$11 for an issue containing less than 200 pages; \$22 for an issue containing 200 to 400 pages; and \$33 for an issue containing more than 400 pages. Single issues of the microfiche edition may be purchased for \$3 per copy, including postage. Remit check or money order, made payable to the Superintendent of Documents, or charge to your GPO Deposit Account, VISA, MasterCard, American Express, or Discover. Mail to: U.S. Government Publishing Office—New Orders, P.O. Box 979050, St. Louis, MO 63197-9000; or call toll free 1-866-512-1800, DC area 202-512-1800; or go to the U.S. Government Online Bookstore site, see bookstore.gpo.gov.

There are no restrictions on the republication of material appearing in the **Federal Register**.

How To Cite This Publication: Use the volume number and the page number. Example: 89 FR 12345.

Postmaster: Send address changes to the Superintendent of Documents, Federal Register, U.S. Government Publishing Office, Washington, DC 20402, along with the entire mailing label from the last issue received.

SUBSCRIPTIONS AND COPIES

PUBLIC

Subscriptions:

Paper or fiche 202-09512-1800
Assistance with public subscriptions 202-512-1806

General online information 202-512-1530; 1-888-293-6498

Single copies/back copies:

Paper or fiche 202-512-1800
Assistance with public single copies 1-866-512-1800
(Toll-Free)

FEDERAL AGENCIES

Subscriptions:

Assistance with Federal agency subscriptions:

Email FRSubscriptions@nara.gov
Phone 202-741-6000

The Federal Register Printing Savings Act of 2017 (Pub. L. 115-120) placed restrictions on distribution of official printed copies of the daily **Federal Register** to members of Congress and Federal offices. Under this Act, the Director of the Government Publishing Office may not provide printed copies of the daily **Federal Register** unless a Member or other Federal office requests a specific issue or a subscription to the print edition. For more information on how to subscribe use the following website link: <https://www.gpo.gov/frsubs>.



Contents

Federal Register

Vol. 89, No. 47

Friday, March 8, 2024

Agriculture Department

See Forest Service
See Rural Utilities Service

Antitrust Division

NOTICES

Changes under the National Cooperative Research and Production Act:
Open Grid Alliance, Inc., 16799–16800

Census Bureau

NOTICES

Agency Information Collection Activities; Proposals, Submissions, and Approvals:
Business and Professional Classification Report, 16722–16723
Collection of State/Local Administrative Records and Third-Party Data, 16720–16722
Quarterly Summary of State and Local Government Tax Revenues, 16722

Centers for Disease Control and Prevention

NOTICES

Charter Amendments, Establishments, Renewals and Terminations:
Clinical Laboratory Improvement Advisory Committee, 16773
Hearings, Meetings, Proceedings, etc.:
Disease, Disability, and Injury Prevention and Control Special Emphasis Panel, 16773

Children and Families Administration

NOTICES

Agency Information Collection Activities; Proposals, Submissions, and Approvals:
Request for Assistance for Child Victims of Human Trafficking, 16773–16774
Survey to Measure Native American Language Vitality, 16774–16776

Coast Guard

RULES

Drawbridge Operations:
Old River, between Victoria Island and Byron Tract, CA, 16688–16690
Portage River, Port Clinton, OH, 16690–16693
Regulated Navigation Area:
Tampa Bay, Tampa, FL, 16693–16695
Safety Zone:
St. Petersburg, FL, 16695–16697
Special Local Regulations:
Lake Havasu Triathlon, Lake Havasu, AZ, 16685
Recurring Marine Events, Sector St. Petersburg, 16685–16688

NOTICES

Agency Information Collection Activities; Proposals, Submissions, and Approvals, 16781–16782

Commerce Department

See Census Bureau
See International Trade Administration
See National Oceanic and Atmospheric Administration

See Patent and Trademark Office

Commission of Fine Arts

NOTICES

Hearings, Meetings, Proceedings, etc., 16735

Committee for Purchase From People Who Are Blind or Severely Disabled

NOTICES

Procurement List; Additions and Deletions, 16735–16736

Education Department

NOTICES

Agency Information Collection Activities; Proposals, Submissions, and Approvals:
Application for Grants under the Educational Opportunity Centers Program, 16743
Applications for New Awards:
Competitive Grants for State Assessments Program, 16750–16757
Gaining Early Awareness and Readiness for Undergraduate Programs (Partnership Grants), 16743–16750
Gaining Early Awareness and Readiness for Undergraduate Programs (State Grants), 16736–16743

Energy Department

See Federal Energy Regulatory Commission

Environmental Protection Agency

RULES

Air Quality State Implementation Plans; Approvals and Promulgations:
California; South Coast Air Quality Management District; Determination to Defer Sanctions, 16698–16700
Standards of Performance for New, Reconstructed, and Modified Sources and Emissions Guidelines for Existing Sources:
Oil and Natural Gas Sector Climate Review, 16820–17227

PROPOSED RULES

Air Quality State Implementation Plans; Approvals and Promulgations:
California; South Coast Air Quality Management District, 16712–16714
Pesticide Tolerance; Exemptions, Petitions, Revocations, etc.:
Tetraacetylenediamine and Its Metabolite Diacetylenediamine, 16714–16717

NOTICES

Environmental Assessments; Availability, etc.:
Deepwater Horizon Natural Resource Damage Assessment Florida Trustee Implementation Group Draft Restoration Plan 3; Water Quality, 16765–16766
Environmental Impact Statements; Availability, etc., 16765
Requests for Nominations:
Science Advisory Board, 16764–16765

Federal Accounting Standards Advisory Board

NOTICES

Exposure Draft:
Seized and Forfeited Digital Assets, 16767

Federal Aviation Administration**RULES**

Airworthiness Criteria:

Special Class Airworthiness Criteria for the Joby Aero, Inc. Model JAS4-1 Powered-lift, 17230-17264

PROPOSED RULES

Airworthiness Directives:

CFE Company Engines, 16710-16712

Restricted Category Special Purpose Operation of Humanitarian, Emergency, and Disaster Aerial Delivery, 16709-16710

NOTICES

Agency Information Collection Activities; Proposals, Submissions, and Approvals:

Certification and Operations: Airplanes with Seating Capacity of 20 or More Passenger Seats or Maximum Payload of 6,000 Pounds or More, 16813-16814

National Airspace System Data Release Request, 16813

Federal Communications Commission**NOTICES**

Agency Information Collection Activities; Proposals, Submissions, and Approvals, 16768-16772

Hearings, Meetings, Proceedings, etc.:

Communications Equity and Diversity Council, 16767-16768

Technological Advisory Council, 16767

Federal Energy Regulatory Commission**RULES**

Natural Gas Pipelines; Project Cost and Annual Limits, 16683-16685

NOTICES

Application:

City of Hamilton, OH and American Municipal Power, Inc., 16763-16764

Authorization for Continued Project Operation:

Appalachian Power Co., 16757-16758

Black Canyon Bliss, LLC, 16758

Eagle Creek Reusens Hydro, LLC, 16761-16762

Combined Filings, 16758-16760, 16762-16763

Environmental Assessments; Availability, etc.:

ANR Pipeline Co., Oak Grove Enhancement Project, 16760-16761

Federal Motor Carrier Safety Administration**NOTICES**

Agency Information Collection Activities; Proposals, Submissions, and Approvals:

Safety Impacts of Human-Automated Driving System Team Driving Applications, 16814-16815

Federal Reserve System**NOTICES**

Change in Bank Control:

Acquisitions of Shares of a Bank or Bank Holding Company, 16772

Foreign Assets Control Office**NOTICES**

Sanctions Action, 16815-16816

Forest Service**NOTICES**

Hearings, Meetings, Proceedings, etc.:

Flathead Resource Advisory Committee, 16718-16719

North Wisconsin Resource Advisory Committee, 16719

Health and Human Services Department

See Centers for Disease Control and Prevention

See Children and Families Administration

See National Institutes of Health

See Substance Abuse and Mental Health Services Administration

Homeland Security Department

See Coast Guard

Indian Affairs Bureau**NOTICES**

Environmental Impact Statements; Availability, etc.:

Koi Nation's Proposed Shiloh Resort and Casino Project, Sonoma County, CA, 16782-16783

Interior Department

See Indian Affairs Bureau

See National Park Service

NOTICES

Privacy Act; Systems of Records, 16783-16786

Internal Revenue Service**NOTICES**

Hearings, Meetings, Proceedings, etc.:

Taxpayer Advocacy Panel Joint Committee, 16816

International Trade Administration**NOTICES**

Antidumping or Countervailing Duty Investigations, Orders, or Reviews:

Certain Glass Wine Bottles from the People's Republic of China, 16723-16724

Hydrofluorocarbon Blends from the People's Republic of China, 16724-16726

Wood Mouldings and Millwork Products from the People's Republic of China, 16726-16729

Justice Department

See Antitrust Division

Labor Department

See Workers Compensation Programs Office

National Aeronautics and Space Administration**NOTICES**

Agency Information Collection Activities; Proposals, Submissions, and Approvals:

STEM Gateway (Universal Registration and Data Management System), 16802

National Archives and Records Administration**RULES**

Making a Privacy Act Request, 16697-16698

NOTICES

Agency Information Collection Activities; Proposals, Submissions, and Approvals, 16802-16803

National Endowment for the Arts**NOTICES**

Hearings, Meetings, Proceedings, etc.:

National Council on the Arts, 16803

National Foundation on the Arts and the Humanities

See National Endowment for the Arts

National Institutes of Health**NOTICES**

Agency Information Collection Activities; Proposals, Submissions, and Approvals:
 Cancer Therapy Evaluation Program Branch and Support Contracts Forms and Surveys, 16776–16779
 Hearings, Meetings, Proceedings, etc.:
 Center for Scientific Review, 16776, 16779–16780
 National Cancer Institute, 16779
 National Institute of Neurological Disorders and Stroke, 16780

National Oceanic and Atmospheric Administration**NOTICES**

Agency Information Collection Activities; Proposals, Submissions, and Approvals:
 National Saltwater Angler Registry and State Exemption Program, 16732–16733
 Sea Grant Program Application Requirements for Grants, etc., 16733–16734
 Hearings, Meetings, Proceedings, etc.:
 Gulf of Mexico Fishery Management Council, 16730
 Request for Information:
 Private Remote Sensing Satellite Disposal and Debris Mitigation, 16730–16731
 Taking or Importing of Marine Mammals:
 Naval Magazine Indian Island Ammunition Wharf Maintenance and Pile Replacement Project, Puget Sound, WA, 16731–16732

National Park Service**NOTICES**

Inventory Completion:
 California State Department of Transportation, Sacramento, CA, 16790
 California State University, Sacramento, Sacramento, CA and East Bay Municipal Utility District, Oakland, CA, 16790–16792
 Longyear Museum of Anthropology, Colgate University, Hamilton, NY, 16789
 University of Oregon Museum of Natural and Cultural History, Eugene, OR, 16786–16788, 16792–16796
 University of Oregon Natural and Cultural History, Eugene, OR, 16796–16797
 William S. Webb Museum of Anthropology, University of Kentucky, Lexington, KY, 16798–16799
 Privacy Act; Systems of Records, 16783–16786
 Repatriation of Cultural Items:
 California State University, Sacramento, Sacramento, CA, 16797
 California State University, Sacramento, Sacramento, CA, and East Bay Municipal Utility District, Oakland, CA, 16797–16798
 Field Museum, Chicago, IL, 16788–16789

Nuclear Regulatory Commission**PROPOSED RULES**

Advance Tribal Notification of Category 1 Quantities of Radioactive Material Shipments, 16701–16709

Patent and Trademark Office**NOTICES**

Hearings, Meetings, Proceedings, etc.:
 Artificial Intelligence/Emerging Technologies Partnership: Public Symposium on Artificial Intelligence and Intellectual Property, 16734–16735

Postal Regulatory Commission**NOTICES**

New Postal Products, 16803–16804

Rural Utilities Service**NOTICES**

Agency Information Collection Activities; Proposals, Submissions, and Approvals:
 Grant Program to Establish a Revolving Fund Program to Finance Water and Wastewater Projects, 16719–16720

Securities and Exchange Commission**NOTICES**

Self-Regulatory Organizations; Proposed Rule Changes:
 Cboe BZX Exchange, Inc., 16804–16806
 New York Stock Exchange LLC, 16806–16808
 NYSE Arca, Inc., 16808–16809
 NYSE Chicago, Inc., 16809–16811
 The Nasdaq Stock Market LLC, 16811–16813

Substance Abuse and Mental Health Services Administration**NOTICES**

Hearings, Meetings, Proceedings, etc.:
 Advisory Committee for Women's Services, 16780–16781

Transportation Department

See Federal Aviation Administration

See Federal Motor Carrier Safety Administration

Treasury Department

See Foreign Assets Control Office

See Internal Revenue Service

U S International Development Finance Corporation**PROPOSED RULES**

Nonprocurement Suspension and Debarment; Correction, 16701

Unified Carrier Registration Plan**NOTICES**

Meetings; Sunshine Act, 16816–16817

Veterans Affairs Department**NOTICES**

Agency Information Collection Activities; Proposals, Submissions, and Approvals:
 COVID-19 Veterans Assistance Partial Claim Payment Program, 16817
 On-The-Job Training Agreement, 16818
 Hearings, Meetings, Proceedings, etc.:
 Advisory Committee on Disability Compensation, 16817–16818

Workers Compensation Programs Office**NOTICES**

Agency Information Collection Activities; Proposals, Submissions, and Approvals:
 Claim for Schedule Award, 16800–16801

Separate Parts In This Issue**Part II**

Environmental Protection Agency, 16820–17227

Part III

Transportation Department, Federal Aviation
Administration, 17230–17264

Reader Aids

Consult the Reader Aids section at the end of this issue for phone numbers, online resources, finding aids, and notice of recently enacted public laws.

To subscribe to the Federal Register Table of Contents electronic mailing list, go to <https://public.govdelivery.com/accounts/USGPOOFR/subscriber/new>, enter your e-mail address, then follow the instructions to join, leave, or manage your subscription.

CFR PARTS AFFECTED IN THIS ISSUE

A cumulative list of the parts affected this month can be found in the Reader Aids section at the end of this issue.

2 CFR**Proposed Rules:**

Ch. XVI16701

10 CFR**Proposed Rules:**

3716701

14 CFR

2117230

Proposed Rules:

2116709

3916710

18 CFR

15716683

33 CFR

100 (2 documents)16685

117 (2 documents)16688,

16690

165 (2 documents)16693,

16695

36 CFR

120216697

40 CFR

5216698

6016820

Proposed Rules:

5216712

18016714

Rules and Regulations

Federal Register

Vol. 89, No. 47

Friday, March 8, 2024

This section of the FEDERAL REGISTER contains regulatory documents having general applicability and legal effect, most of which are keyed to and codified in the Code of Federal Regulations, which is published under 50 titles pursuant to 44 U.S.C. 1510.

The Code of Federal Regulations is sold by the Superintendent of Documents.

DEPARTMENT OF ENERGY

Federal Energy Regulatory Commission

18 CFR Part 157

[Docket No. RM81-19-000]

Natural Gas Pipelines; Project Cost and Annual Limits

AGENCY: Federal Energy Regulatory Commission, Energy.

ACTION: Final rule.

SUMMARY: Pursuant to the authority delegated by the Commission's regulations, the Director of the Office of Energy Projects (OEP) computes and publishes the project cost and annual limits for natural gas pipelines blanket construction certificates for each calendar year.

DATES: This final rule is effective March 8, 2024, and establishes cost limits applicable from January 1, 2024, through December 31, 2024.

FOR FURTHER INFORMATION CONTACT: Daniel Green; Chief, Certificates Branch 2; Division of Pipeline Certificates; (202) 502-8755.

SUPPLEMENTARY INFORMATION: Section 157.208(d) of the Commission's Regulations provides for project cost limits applicable to construction, acquisition, operation, and miscellaneous rearrangement of facilities (table 1 to paragraph (d))

authorized under the blanket certificate procedure (Order No. 234, 19 FERC ¶ 61,216, 47 FR 24266). Section 157.215(a) specifies the calendar year dollar limit which may be expended on underground storage testing and development (table 1 to paragraph (a)(5)) authorized under the blanket certificate. Section 157.208(d) requires that the "limits specified in table 1 to this paragraph (d) and table 1 to § 157.215(a)(5) shall be adjusted each calendar year to reflect the 'GDP implicit price deflator' published by the Department of Commerce for the previous calendar year."

Pursuant to § 375.308(x)(1) of the Commission's Regulations, the authority for the publication of such cost limits, as adjusted for inflation, is delegated to the Director of the Office of Energy Projects. The cost limits for calendar year 2024, as published in table 1 to paragraph (d) of § 157.208 and table 1 to paragraph (a)(5) of § 157.215, are hereby issued.

Effective Date

This final rule is effective March 8, 2024. The provisions of 5 U.S.C. 804 regarding congressional review of Final Rules does not apply to the final rule because the rule concerns agency procedure and practice and will not substantially affect the rights or obligations of non-agency parties. The final rule merely updates amounts published in the Code of Federal Regulations to reflect the Department of Commerce's latest annual determination of the Gross Domestic Product (GDP) implicit price deflator, a mathematical updating required by the Commission's existing regulations.

List of Subjects in 18 CFR Part 157

Administrative practice and procedure, Natural Gas, Reporting and recordkeeping requirements.

Issued: February 28, 2024.

Terry L. Turpin,

Director, Office of Energy Projects.

Accordingly, 18 CFR part 157 is amended as follows:

PART 157—APPLICATIONS FOR CERTIFICATES OF PUBLIC CONVENIENCE AND NECESSITY AND FOR ORDERS PERMITTING AND APPROVING ABANDONMENT UNDER SECTION 7 OF THE NATURAL GAS ACT

■ 1. The authority citation for part 157 continues to read as follows:

Authority: 15 U.S.C. 717-717w, 3301-3432; 42 U.S.C. 7101-7352.

■ 2. In § 157.208:

■ a. Amend paragraph (a) by removing "Table I, under" and "Table I" and add in their places "table 1 to" and "table 1 to paragraph (d)", respectively.

■ b. Amend paragraph (b) by removing "Table I, but" and "Table I" adding "table 1 to paragraph (d) of this section, but" and "table 1 to paragraph (d)" in their places, respectively.

■ c. Amend paragraph (d) by:

■ i. In the introductory text, removing "Tables I and II" and adding "table 1 to this paragraph (d) and table 1 to § 157.215(a)(5)" in its place.

■ ii. Revising the table.

■ d. Amend paragraphs (f)(1) and (g) by removing "Table I" and adding "table 1 to paragraph (d)" in its place.

The revision reads as follows:

§ 157.208 Construction, acquisition, operation, replacement, and miscellaneous rearrangement of facilities.

* * * * *

(d) * * *

TABLE 1 TO PARAGRAPH (d)

Year	Limit	
	Auto. proj. cost limit (col. 1)	Prior notice proj. cost limit (col. 2)
1982	\$4,200,000	\$12,000,000
1983	4,500,000	12,800,000
1984	4,700,000	13,300,000
1985	4,900,000	13,800,000
1986	5,100,000	14,300,000
1987	5,200,000	14,700,000

TABLE 1 TO PARAGRAPH (d)—Continued

Table with 3 columns: Year, Auto. proj. cost limit (col. 1), and Prior notice proj. cost limit (col. 2). Rows range from 1988 to 2024.

* * * * *

§ 157.209 [Amended]

■ 3. In § 157.209, amend paragraph (a) by removing “Table I, under § 157.208(d) of this chapter” and adding “table 1 to § 157.208(d)” in its place.

§ 157.210 [Amended]

■ 4. In § 157.210, remove “Table I of” and add “table 1 to” in its place.

§ 157.212 [Amended]

■ 5. In § 157.212, remove “Table I in” and add “table 1 to” in its place.

§ 157.213 [Amended]

■ 6. In § 157.213, amend paragraphs (a) and (b) by removing “Table I in” and add “table 1 to” in its place.

■ 7. In § 157.215, amend paragraph (a)(5) by:

- a. Removing “Table II” from the introductory text and adding “table 1 to this paragraph (a)(5)” in its place.
■ b. Revising table 1.

The revision reads as follows:

§ 157.215 Underground storage testing and development.

- (a) * * *
(5) * * *

TABLE 1 TO PARAGRAPH (a)(5)

Table with 2 columns: Year and Limit. Rows range from 1982 to 1998.

TABLE 1 TO PARAGRAPH (a)(5)—Continued

Table with 2 columns: Year and Limit. Rows range from 1999 to 2021.

TABLE 1 TO PARAGRAPH (a)(5)—
Continued

Year	Limit
2022	7,100,000
2023	7,600,000
2024	7,900,000

* * * * *

[FR Doc. 2024-04726 Filed 3-7-24; 8:45 am]

BILLING CODE 6717-01-P

DEPARTMENT OF HOMELAND SECURITY

Coast Guard

33 CFR Part 100

[Docket No. USCG-2024-0175]

Special Local Regulations; Lake Havasu Triathlon, Lake Havasu, AZ

AGENCY: Coast Guard, Department of Homeland Security (DHS).

ACTION: Notification of enforcement of regulation.

SUMMARY: The Coast Guard will enforce the Lake Havasu Triathlon special local regulations on the waters of the Colorado River on March 17, 2024. These special local regulations are necessary to provide for the safety of the participants, crew, spectators, sponsor vessels, and general users of the waterway. During the enforcement period, persons and vessels are prohibited from anchoring, blocking, loitering, or impeding within this regulated area unless authorized by the Captain of the Port, or his designated representative.

DATES: The regulations in 33 CFR 100.1102 will be enforced from 5:30 a.m. through 10:30 a.m. on March 17, 2024, for the location described in Item 15 of Table 1 to § 100.1102.

FOR FURTHER INFORMATION CONTACT: If you have questions about this notification of enforcement, call or email Lieutenant Shelley Turner, Waterways Management Division, US Coast Guard Sector San Diego, CA; telephone (619) 278-7656, email D11MarineEventsSD@uscg.mil.

SUPPLEMENTARY INFORMATION: The Coast Guard will enforce the special local regulations in 33 CFR 100.1102 for the Lake Havasu Triathlon in Lake Havasu, AZ for the locations described in item 15 of Table 1 to § 100.1102 from 5:30 a.m. until 10:30 a.m. on March 17, 2024. The location includes the waters of the Colorado River, AZ, including the Lake Havasu Channel. This enforcement

action is being taken to provide for the safety of life on navigable waterways during the event. The Coast Guard’s regulation for recurring marine events in the San Diego Captain of the Port Zone identifies the regulated entities and area for this event. Under the provisions of 33 CFR 100.1102, persons and vessels are prohibited from anchoring, blocking, loitering, or impeding within this regulated area, unless authorized by the Captain of the Port, or his designated representative. The Coast Guard may be assisted by other Federal, State, or local law enforcement agencies in enforcing this regulation.

In addition to this document in the **Federal Register**, the Coast Guard will provide the maritime community with advance notification of this enforcement period via the Local Notice to Mariners, marine information broadcasts, and local advertising by the event sponsor.

If the Captain of the Port Sector San Diego or his designated representative determines that the regulated area need not be enforced for the full duration stated on this document, he or she may use a Broadcast Notice to Mariners or other communications coordinated with the event sponsor to grant general permission to enter the regulated area.

James W. Spittler,
Captain, U.S. Coast Guard, Captain of the Port San Diego.

[FR Doc. 2024-04906 Filed 3-7-24; 8:45 am]

BILLING CODE 9110-04-P

DEPARTMENT OF HOMELAND SECURITY

Coast Guard

33 CFR Part 100

[Docket Number USCG-2023-0597]

RIN 1625-AA08

Special Local Regulations; Recurring Marine Events, Sector St. Petersburg

AGENCY: Coast Guard, Department of Homeland Security (DHS).

ACTION: Final rule.

SUMMARY: The Coast Guard is revising existing regulations by updating the duration of an existing event in the Seventh Coast Guard District Captain of the Port St. Petersburg Zone. This action is necessary to provide for the safety of life on the navigable waters in Clearwater, FL, during the Clearwater Offshore Nationals/Race World Offshore event.

DATES: This rule is effective April 8, 2024.

ADDRESSES: To view documents mentioned in this preamble as being available in the docket, go to <https://www.regulations.gov>, type USCG-2023-0597 in the search box and click “Search.” Next, in the Document Type column, select “Supporting & Related Material.”

FOR FURTHER INFORMATION CONTACT: If you have questions about this rule, call or email Marine Science Technician First Class Mara J. Brown, Sector St. Petersburg Prevention Department, Coast Guard; telephone 813-228-2191 (ext. 8151), email Mara.J.Brown@uscg.mil.

SUPPLEMENTARY INFORMATION:

I. Table of Abbreviations

CFR Code of Federal Regulations
COTP Captain of the Port
DHS Department of Homeland Security
FR Federal Register
NPRM Notice of proposed rulemaking
§ Section
U.S.C. United States Code

II. Background Information and Regulatory History

The Coast Guard is revising the Recurring Marine Events in the geographic boundaries of the Seventh Coast Guard District Captain of the Port (COTP) St. Petersburg Zone that are listed in 33 CFR 100.703, Table 1 to § 100.703. The change is to Line No. 6 located under Date/time, existing as “One Sunday in September; Time (Approximate): 11:30 a.m. to 4:00 p.m.” The event sponsor has changed the duration of the event to a two-day event; revising the Date/time as “One weekend (Saturday and Sunday) in September; Time (Approximate): 8:00 a.m. to 4:00 p.m.”

On August 4, 2023, the Coast Guard published a notice of proposed rulemaking (NPRM) titled, Special Local Regulations; Recurring Marine Events, Sector St. Petersburg.¹ There we stated why we issued the NPRM and invited comments on our proposed regulatory action related to our table. During the comment period that ended September 5, 2023, we received no comments.

III. Legal Authority and Need for Rule

The Coast Guard is issuing this rule under authority in 46 U.S.C. 70034. The COTP Sector St. Petersburg has determined that potential hazards associated with Clearwater Offshore Nationals/Race World Offshore high-speed boat race, will be a safety concern for anyone within the regulated area. The purpose of this rule is to ensure safety of vessels and the navigable

¹ 88 FR 51763.

waters in the regulated area before, during, and after the scheduled event.

IV. Discussion of Comments, Changes, and the Rule

As noted above, we received no comments on our NPRM published August 4, 2023. There are no changes in the regulatory text of this rule from the proposed rule in the NPRM.

This rule establishes the following changes in 33 CFR 100.703:

1. Revise Table 1 to § 100.703, Line No. 6, to reflect a date and time change. Marine events listed in Table 1 to § 100.703 are listed as recurring over a particular time, during each month and each year. Exact dates are intentionally omitted since calendar dates for specific events change from year to year. Once dates for a marine event are known, the Coast Guard notifies the public it intends to enforce the special local regulation through various means including a notice of enforcement published in the **Federal Register**, Local Notice to Mariners, and Broadcast Notice to Mariners.

V. Regulatory Analyses

We developed this rule after considering numerous statutes and Executive orders related to rulemaking. Below we summarize our analyses based on a number of these statutes and Executive orders.

A. Regulatory Planning and Review

Executive Orders 12866 and 13563 direct agencies to assess the costs and benefits of available regulatory alternatives and, if regulation is necessary, to select regulatory approaches that maximize net benefits. This rule has not been designated a “significant regulatory action,” under section 3(f) of Executive Order 12866, as amended by Executive Order 14094 (Modernizing Regulatory Review). Accordingly, this rule has not been reviewed by the Office of Management and Budget (OMB).

This regulatory action determination is based on the size, location, duration, and time of day of the regulated area. These areas are limited in size and duration, and usually do not affect high vessel traffic areas. Moreover, the Coast Guard would provide advance notice of the regulated areas to the local maritime community by Local Notice to Mariners, Broadcast Notice to Mariners via VHF-FM marine channel 16, and the rule would allow vessels to seek permission to enter the regulated area.

B. Impact on Small Entities

The Regulatory Flexibility Act of 1980, 5 U.S.C. 601–612, as amended,

requires Federal agencies to consider the potential impact of regulations on small entities during rulemaking. The term “small entities” comprises small businesses, not-for-profit organizations that are independently owned and operated and are not dominant in their fields, and governmental jurisdictions with populations of less than 50,000. The Coast Guard received no comments from the Small Business Administration on this rulemaking. The Coast Guard certifies under 5 U.S.C. 605(b) that this rule will not have a significant economic impact on a substantial number of small entities.

While some owners or operators of vessels intending to transit the safety zone may be small entities, for the reasons stated in section V.A above, this rule will not have a significant economic impact on any vessel owner or operator.

Under section 213(a) of the Small Business Regulatory Enforcement Fairness Act of 1996 (Pub. L. 104–121), we want to assist small entities in understanding this rule. If the rule would affect your small business, organization, or governmental jurisdiction and you have questions concerning its provisions or options for compliance, please call or email the person listed in the **FOR FURTHER INFORMATION CONTACT** section.

Small businesses may send comments on the actions of Federal employees who enforce, or otherwise determine compliance with, Federal regulations to the Small Business and Agriculture Regulatory Enforcement Ombudsman and the Regional Small Business Regulatory Fairness Boards. The Ombudsman evaluates these actions annually and rates each agency’s responsiveness to small business. If you wish to comment on actions by employees of the Coast Guard, call 1–888–REG–FAIR (1–888–734–3247). The Coast Guard will not retaliate against small entities that question or complain about this rule or any policy or action of the Coast Guard.

C. Collection of Information

This rule will not call for a new collection of information under the Paperwork Reduction Act of 1995 (44 U.S.C. 3501–3520).

D. Federalism and Indian Tribal Governments

A rule has implications for federalism under Executive Order 13132, Federalism, if it has a substantial direct effect on the States, on the relationship between the National Government and the States, or on the distribution of power and responsibilities among the

various levels of government. We have analyzed this rule under that order and have determined that it is consistent with the fundamental federalism principles and preemption requirements described in Executive Order 13132.

Also, this rule does not have tribal implications under Executive Order 13175, Consultation and Coordination with Indian Tribal Governments, because it does not have a substantial direct effect on one or more Indian tribes, on the relationship between the Federal Government and Indian tribes, or on the distribution of power and responsibilities between the Federal Government and Indian tribes.

E. Unfunded Mandates Reform Act

The Unfunded Mandates Reform Act of 1995 (2 U.S.C. 1531–1538) requires Federal agencies to assess the effects of their discretionary regulatory actions. In particular, the Act addresses actions that may result in the expenditure by a State, local, or tribal government, in the aggregate, or by the private sector of \$100,000,000 (adjusted for inflation) or more in any one year. Though this rule will not result in such an expenditure, we do discuss the effects of this rule elsewhere in this preamble.

F. Environment

We have analyzed this rule under Department of Homeland Security Directive 023–01, Rev. 1, associated implementing instructions, and Environmental Planning COMDTINST 5090.1 (series), which guide the Coast Guard in complying with the National Environmental Policy Act of 1969 (42 U.S.C. 4321–4370f), and have determined that this action is one of a category of actions that do not individually or cumulatively have a significant effect on the human environment. This rule involves revising an existing recurring event to reflect a date and time change for the event. It is categorically excluded from further review under paragraphs L61 in Table 3–1 of Appendix A, Table 1 of DHS Instruction Manual 023–01–001–01, Rev. 1.

G. Protest Activities

The Coast Guard respects the First Amendment rights of protesters. Protesters are asked to call or email the person listed in the **FOR FURTHER INFORMATION CONTACT** section to coordinate protest activities so that your message can be received without jeopardizing the safety or security of people, places or vessels.

List of Subjects in 33 CFR Part 100

Harbors, Marine safety, Navigation (water), Reporting and recordkeeping requirements, Security measures, Waterways.

For the reasons discussed in the preamble, the Coast Guard amends 33 CFR part 100 as follows:

PART 100—SAFETY OF LIFE ON NAVIGABLE WATERS

■ 1. The authority citation for part 100 continues to read as follows:

Authority: 46 U.S.C. 70041; 33 CFR 1.05–1.

■ 2. In § 100.703, revise Table 1 to read as follows:

§ 100.703 Special Local Regulations; Recurring Marine Events, Sector St. Petersburg.

* * * * *

TABLE 1 TO § 100.703—SPECIAL LOCAL REGULATIONS; RECURRING MARINE EVENTS, SECTOR ST. PETERSBURG [Datum NAD 1983]

Date/time	Event/sponsor	Location	Regulated area
1. One Saturday in January. Time (Approximate): 11:30 a.m. to 2 p.m.	Gasparilla Invasion and Parade/Ye Mystic Krewe of Gasparilla.	Tampa, Florida	<p>Location: A regulated area is established consisting of the following waters of Hillsborough Bay and its tributaries north of 27°51'18" N and south of the John F. Kennedy Bridge: Hillsborough Cut "D" Channel, Seddon Channel, Sparkman Channel and the Hillsborough River south of the John F. Kennedy Bridge.</p> <p>Additional Regulation: (1) Entrance into the regulated area is prohibited to all commercial marine traffic from 9 a.m. to 6 p.m. EST on the day of the event. (2) The regulated area will include a 100 yard Safety Zone around the vessel JOSE GASPARGAR while docked at the Tampa Yacht Club until 6 p.m. EST on the day of the event. (3) The regulated area is a "no wake" zone. (4) All vessels within the regulated area shall stay 50 feet away from and give way to all officially entered vessels in parade formation in the Gasparilla Marine Parade. (5) When within the marked channels of the parade route, vessels participating in the Gasparilla Marine Parade may not exceed the minimum speed necessary to maintain steerage. (6) Jet skis and vessels without mechanical propulsion are prohibited from the parade route. (7) Vessels less than 10 feet in length are prohibited from the parade route unless capable of safely participating. (8) Vessels found to be unsafe to participate at the discretion of a present Law Enforcement Officer are prohibited from the parade route. (9) North-bound vessels in excess of 65 feet in length without mooring arrangement made prior to the date of the event are prohibited from entering Seddon Channel unless the vessel is officially entered in the Gasparilla Marine Parade. (10) Vessels not officially entered in the Gasparilla Marine Parade may not enter the parade staging area box within the following coordinates: 27°53'53" N, 082°27'47" W; 27°53'22" N, 082°27'10" W; 27°52'36" N, 082°27'55" W; 27°53'02" N, 082°28'31" W.</p>
2. One Saturday in February. Time (Approximate): 9 a.m. to 9 p.m.	Bradenton Area River Regatta/City of Bradenton.	Bradenton, FL	<p>Location(s): <i>Enforcement Area #1.</i> All waters of the Manatee River between the Green Bridge and the CSX Train Trestle contained within the following points: 27°30'43" N, 082°34'20" W, thence to position 27°30'44" N, 082°34'09" W, thence to position 27°30'00" N, 082°34'04" W, thence to position 27°29'58" N, 082°34'15" W, thence back to the original position, 27°30'43" N, 082°34'20" W. <i>Enforcement Area #2.</i> All waters of the Manatee River contained within the following points: 27°30'35" N, 082°34'37" W, thence to position 27°30'35" N, 082°34'26" W, thence to position 27°30'26" N, 082°34'26" W, thence to position 27°30'26" N, 082°34'37" W, thence back to the original position, 27°30'35" N, 082°34'37" W.</p>
3. One weekend (Friday, Saturday, and Sunday) in March. Time (Approximate): 8 a.m. to 5 p.m.	Gulfport Grand Prix/ Gulfport Grand Prix LLC.	Gulfport, FL	<p>Location(s): (1) <i>Race Area.</i> All waters of Boca de Ciego contained within the following points: 27°44'10" N, 082°42'29" W, thence to position 27°44'07" N, 082°42'40" W, thence to position 27°44'06" N, 082°42'40" W, thence to position 27°44'04" N, 082°42'29" W, thence to position 27°44'07" N, 082°42'19" W, thence to position 27°44'08" N, 082°42'19" W, thence back to the original position, 27°44'10" N, 082°42'29" W. (2) <i>Buffer Zone.</i> All waters of Boca de Ciego encompassed within the following points: 27°44'10" N, 082°42'47" W, thence to position 27°44'01" N, 082°42'44" W, thence to position 27°44'01" N, 082°42'14" W, thence to position 27°44'15" N, 082°42'14" W.</p>
4. One weekend (Saturday and Sunday) in July. Time (Approximate): 8 a.m. to 5 p.m.	Sarasota Powerboat Grand Prix/Powerboat P-1 USA, LLC.	Sarasota, FL	<p>Location: All waters of the Gulf of Mexico contained within the following points: 27°18'44" N, 082°36'14" W, thence to position 27°19'09" N, 082°35'13" W, thence to position 27°17'42" N, 082°34'00" W, thence to position 27°16'43" N, 082°34'49" W, thence back to the original position, 27°18'44" N, 082°36'14" W.</p>
5. One weekend (Saturday and Sunday) in September. Time (Approximate): 8 a.m. to 4 p.m.	St.Petersburg P-1 Powerboat Grand Prix.	St. Petersburg, FL	<p>Location: All waters of the Tampa Bay encompassed within the following points: 27°46'56.22" N, 082°36'55.50" W, thence to position 27°47'08.82" N, 082°34'33.24" W, thence to position 27°46'06.96" N, 082°34'29.04" W, thence to position 27°45'59.22" N, 082°37'02.88" W, thence back to the original position 27°46'24.24" N, 082°37'30.24" W.</p>
6. One weekend (Saturday and Sunday) in September. Time (Approximate): 8 a.m. to 4 p.m.	Clearwater Offshore Nationals/Race World Offshore.	Clearwater, FL	<p>Locations: (1) <i>Race Area.</i> All waters of the Gulf of Mexico contained within the following points: 27°58'34" N, 82°50'09" W, thence to position 27°58'32" N, 82°50'02" W, thence to position 28°00'12" N, 82°50'10" W, thence to position 28°00'13" N, 82°50'10" W, thence back to the original position, 27°58'34" N, 82°50'09" W. (2) <i>Spectator Area.</i> All waters of Gulf of Mexico seaward no less than 150 yards from the race area and as agreed upon by the Coast Guard and race officials. (3) <i>Enforcement Area.</i> All waters of the Gulf of Mexico encompassed within the following points: 28°58'40" N, 82°50'37" W, thence to position 28°00'57" N, 82°49'45" W, thence to position 27°58'32" N, 82°50'32" W, thence to position 27°58'23" N, 82°49'53" W, thence back to position 28°58'40" N, 82°50'37" W.</p>
7. One Thursday, Friday, and Saturday in October. Time (Approximate): 10 a.m. to 5 p.m.	Roar Offshore/OPA Racing LLC.	Fort Myers Beach, FL	<p>Locations: All waters of the Gulf of Mexico west of Fort Myers Beach contained within the following points: 26°26'27" N, 081°55'55" W, thence to position 26°25'33" N, longitude 081°56'34" W, thence to position 26°26'38" N, 081°58'40" W, thence to position 26°27'25" N, 081°58'8" W, thence back to the original position 26°26'27" N, 081°55'55" W.</p>

TABLE 1 TO § 100.703—SPECIAL LOCAL REGULATIONS; RECURRING MARINE EVENTS, SECTOR ST. PETERSBURG—
Continued
[Datum NAD 1983]

Date/time	Event/sponsor	Location	Regulated area
8. One weekend (Friday, Saturday, and Sunday) in November. Time (Approximate): 8 a.m. to 6 p.m.	OPA World Championships/Englewood Beach Waterfest.	Englewood Beach, FL	Locations: (1) <i>Race Area</i> . All waters of the Gulf of Mexico contained within the following points: 26°56'00" N, 082°22'11" W, thence to position 26°55'59" N, 082°22'16" W, thence to position 26°54'22" N, 082°21'20" W, thence to position 26°54'24" N, 082°21'16" W, thence to position 26°54'25" N, 082°21'17" W, thence back to the original position, 26°56'00" N, 082°21'11" W. (2) <i>Spectator Area</i> . All waters of the Gulf of Mexico contained within the following points: 26°55'33" N, 082°22'21" W, thence to position 26°54'14" N, 082°21'35" W, thence to position 26°54'11" N, 082°21'40" W, thence to position 26°55'31" N, 082°22'26" W, thence back to position 26°55'33" N, 082°22'21" W. (3) <i>Enforcement Area</i> . All waters of the Gulf of Mexico encompassed within the following points: 26°56'09" N, 082°22'12" W, thence to position 26°54'13" N, 082°21'03" W, thence to position 26°53'58" N, 082°21'43" W, thence to position 26°55'56" N, 082°22'48" W, thence back to position 26°56'09" N, 082°22'12" W.

Dated: March 1, 2024.

Michael P. Kahle,

Captain, U.S. Coast Guard, Captain of the Port Sector St. Petersburg.

[FR Doc. 2024-05009 Filed 3-7-24; 8:45 am]

BILLING CODE 9110-04-P

DEPARTMENT OF HOMELAND SECURITY

Coast Guard

33 CFR Part 117

[Docket No. USCG-2023-0231]

RIN 1625-AA09

Drawbridge Operation Regulation; Old River, Between Victoria Island and Byron Tract, CA

AGENCY: Coast Guard, Department of Homeland Security (DHS).

ACTION: Temporary interim rule and request for comments.

SUMMARY: The Coast Guard is temporarily modifying the operating schedule that governs the draw of the California Department of Transportation (Route 4) highway bridge, mile 14.8 between Victoria Island and Byron Tract, CA. This action is necessary to allow the bridge owner to complete rehabilitation of the bridge after a continuing unexpected delay in installing We can't have and testing of the custom-made electronics.

DATES: Effective March 8, 2024, 33 CFR 117.183 is stayed until 5 p.m. on May 31, 2024. The temporary addition of 33 CFR 117.T184 is effective from 5 p.m. on March 8, 2024 through 5 p.m. on May 31, 2024. Comments and related material must reach the Coast Guard on or before April 8, 2024.

ADDRESSES: To view documents mentioned in this preamble as being available in the docket, go to <https://www.regulations.gov>. Type the docket

number (USCG-2023-0231) in the "SEARCH" box and click "SEARCH". In the Document Type column, select "Supporting & Related Material".

FOR FURTHER INFORMATION CONTACT: If you have questions on this temporary interim rule, call or email Carl Hausner, Chief, Bridge Section, Eleventh Coast Guard District; telephone 510-437-3516, email Carl.T.Hausner@uscg.mil.

SUPPLEMENTARY INFORMATION:

I. Table of Abbreviations [Delete/Add Any Abbreviations Not Used/Used in This Document]

- CFR Code of Federal Regulations
- Caltrans California Department of Transportation
- CADFW California Department of Fish and Wildlife
- DHS Department of Homeland Security
- FR Federal Register
- NPRM Notice of proposed rulemaking
- Pub. L. Public Law
- § Section
- U.S.C. United States Code

II. Background Information and Regulatory History

The Coast Guard is issuing this temporary interim rule without prior notice and opportunity to comment pursuant to authority under section 4(a) of the Administrative Procedure Act (APA) (5 U.S.C. 553(b)). This provision authorizes an agency to issue a rule without prior notice and opportunity to comment when the agency for good cause finds that those procedures are "impracticable, unnecessary, or contrary to the public interest." Under 5 U.S.C. 553(b), the Coast Guard finds that good cause exists for not publishing a notice of proposed rulemaking (NPRM) with respect to this rule because it is impracticable. This bridge is non-operational and will be non-operational until rehabilitation work can be completed.

On October 27, 2022, the Coast Guard issued a General Deviation which

allowed the bridge owner, Caltrans, to deviate from the current operating schedule in 33 CFR 117.183 to conduct major mechanical and electrical rehabilitation of the bridge. Due to delays in procuring materials, vandalism of critical electrical submarine cables, and an active winter storm season, the project ran past the end date of April 23, 2023, of the General Deviation. The bridge could not be brought back to operating condition until the delivery of the critical Program Logic Control circuit and the replacement or repairs to the submarine cable could be made. On October 17, 2023, Caltrans informed the Coast Guard that critical electronic components, needed to complete the rehabilitation of the bridge, were still on back-order and not expected to be delivered in time for a project completion deadline of November 30, 2023. It was anticipated that the parts would be delivered in the beginning of the new year, the bridge work completed and the span operational by March 1, 2024. There was insufficient time to provide a reasonable comment period and then consider those comments before issuing the modification. On January 30, 2024, Caltrans notified the Coast Guard that the bridge would not be operational by March 1, 2024. The back ordered critical electronic components have been received and are currently being installed. After the installation of the electronic components, critical testing of the span must be conducted before it is put back into operation. Therefore, it is now anticipated the span will be fully operational by 5 p.m. on May 31, 2024.

Under 5 U.S.C. 553(d)(3), the Coast Guard finds that good cause exists for making this rule effective in less than 30 days after publication in the **Federal Register**. For reasons presented above, delaying the effective date of this rule would be impracticable and contrary to the public interest due to the fact that

the bridge is currently inoperable and will not be back into operation until the rehabilitation work can be completed.

We are soliciting comments on this rulemaking. If the Coast Guard determines that changes to the temporary interim rule are necessary, we will publish a temporary final rule or other appropriate document.

III. Legal Authority and Need for Rule

The Coast Guard is issuing this temporary interim rule under authority in 33 U.S.C. 499. The Coast Guard is modifying the operating schedule that governs the California Department of Transportation (Route 4) highway bridge, mile 14.8 between Victoria Island and Byron Tract, California. The Caltrans Route 4 highway bridge has a vertical clearance, in the closed position, of 12.7 feet at mean high water and unlimited vertical clearance when opened.

The existing drawbridge regulation, 33 CFR 117.183, states that the draw of the California Department of Transportation (Route 4) highway bridge, mile 14.8 between Victoria Island and Byron Tract, shall open on signal if at least four hours notice is given to the drawtender at the Rio Vista bridge across the Sacramento River, mile 12.8. Caltrans, the bridge owner, has requested this modification as additional time is required to complete the bridge rehabilitation.

Drawtender logs, during a previous test deviation conducted May 5, 2021, to August 7, 2021, recorded the following number of CADFW vessel openings: four in May, eight in June, four in July, and two in August. One survey vessel passed in July. No recreational or commercial vessels requested an opening of the bridge span during that 90-day test deviation.

On October 27, 2022, the Coast Guard issued a General Deviation which allowed the bridge owner, Caltrans, to deviate from the current operating schedule in 33 CFR 117.183 to conduct major mechanical and electrical rehabilitation of the bridge. Due to various delays, the project ran past the end date of April 23, 2023, of the General Deviation. On April 20, 2023, the Coast Guard published a temporary interim rule with request for comments that extended the deviation from the operating schedule until November 30, 2023 (88 FR 24336). During the comment period that ended May 22, 2023, no comments were received.

On October 17, 2023, Caltrans informed the Coast Guard that critical electronic components, needed to complete the rehabilitation of the bridge, were still on back order and not

expected to be delivered in time for a project completion deadline of November 30, 2023. It was anticipated that the parts would be delivered in the beginning of 2024, the bridge work completed and the span operational by March 1, 2024. During the comment period that ended December 28, 2023, no comments were received (88 FR 83026).

On January 30, 2024, Caltrans once again informed the Coast Guard that an extension would be needed to complete the rehabilitation of the bridge. The back ordered electronic components have been delivered but installation of the parts is still ongoing, and the span will require testing before it can be put back in service.

This temporary interim rule allows for a further deviation from the operating schedule until May 31, 2024.

IV. Discussion of the Rule

The Coast Guard is issuing this rule, which permits a temporary deviation from the operating schedule that governs the California Department of Transportation (Route 4) highway bridge, mile 14.8 between Victoria Island and Byron Tract, California. This rule allows the bridge to be secured in the closed-to-navigation position through 5 p.m. on May 31, 2024.

As part of the rehabilitation of the bridge, Caltrans has removed and is replacing all the electronics as well as key mechanical components that control the operation of the swing span. On January 31, 2023, vandals caused damage to one of the three newly installed custom-made submarine cables. On April 1, 2023, the contractor informed Caltrans that the custom-made Program Logic Control circuit, which is the circuit that controls the operation of the swing span, was delayed due to supply chain issues. These two critical components of bridge operations, as well as an active storm season, caused the delay of the completion of the rehabilitation of the bridge. On October 17, 2023, Caltrans informed the Coast Guard that critical electronic components, needed to complete the rehabilitation of the bridge, were still on back order and not expected to be delivered to meet the November 30, 2023, deadline, to bring the swing span back into operation. It was anticipated that the parts would be delivered in the beginning of 2024, the bridge work completed and the span operational by March 1, 2024. On January 30, 2024, Caltrans once again informed the Coast Guard that an extension of time was needed to complete the work. The critical electronic components have been received and are currently being

installed. After installation is complete, testing of the swing span is necessary before returning the bridge to operational status.

Currently, the swing span remains inoperable until rehabilitation work is completed. The anticipated completion of the rehabilitation work is May 31, 2024.

V. Regulatory Analyses

We developed this temporary interim rule after considering numerous statutes and Executive orders related to rulemaking. Below we summarize our analyses based on a number of these statutes and Executive orders.

A. Regulatory Planning and Review

Executive Orders 12866 and 13563 direct agencies to assess the costs and benefits of available regulatory alternatives and, if regulation is necessary, to select regulatory approaches that maximize net benefits. This rule has not been designated a “significant regulatory action,” under Executive Order 12866, as amended by Executive Order 14094 (Modernizing Regulatory Review). Accordingly, it has not been reviewed by the Office of Management and Budget (OMB).

This regulatory action determination is based on the fact that little, or no commercial or recreational vessel traffic will be impacted by this rule. Furthermore, the swing span of the bridge, as of date of the publication of this rule, is not operational and cannot resume operations until installation of the delivered parts have been completed and the bridge’s swing span tested.

B. Impact on Small Entities

The Regulatory Flexibility Act of 1980 (RFA), 5 U.S.C. 601–612, as amended, requires Federal agencies to consider the potential impact of regulations on small entities during rulemaking. The term “small entities” comprises small businesses, not-for-profit organizations that are independently owned and operated and are not dominant in their fields, and governmental jurisdictions with populations of less than 50,000. The Coast Guard certifies under 5 U.S.C. 605(b) that this rule will not have a significant economic impact on a substantial number of small entities.

While some owners or operators of vessels intending to transit the bridge may be small entities, for the reasons stated in section V.A above, this rule will not have a significant economic impact on any vessel owner or operator.

Under section 213(a) of the Small Business Regulatory Enforcement Fairness Act of 1996 (Pub. L. 104–121), we want to assist small entities in

understanding this rule. If the rule would affect your small business, organization, or governmental jurisdiction and you have questions concerning its provisions or options for compliance, please contact the person listed in the **FOR FURTHER INFORMATION CONTACT** section.

Small businesses may send comments on the actions of Federal employees who enforce, or otherwise determine compliance with, Federal regulations to the Small Business and Agriculture Regulatory Enforcement Ombudsman and the Regional Small Business Regulatory Fairness Boards. The Ombudsman evaluates these actions annually and rates each agency's responsiveness to small business. If you wish to comment on actions by employees of the Coast Guard, call 1-888-REG-FAIR (1-888-734-3247). The Coast Guard will not retaliate against small entities that question or complain about this rule or any policy or action of the Coast Guard.

C. Collection of Information

This rule calls for no new collection of information under the Paperwork Reduction Act of 1995 (44 U.S.C. 3501-3520).

D. Federalism and Indian Tribal Government

A rule has implications for federalism under Executive Order 13132, Federalism, if it has a substantial direct effect on the States, on the relationship between the national government and the States, or on the distribution of power and responsibilities among the various levels of government. We have analyzed this rule under that order and have determined that it is consistent with the fundamental federalism principles and preemption requirements described in Executive Order 13132.

Also, this rule does not have tribal implications under Executive Order 13175, Consultation and Coordination with Indian Tribal Governments, because it does not have a substantial direct effect on one or more Indian tribes, on the relationship between the Federal Government and Indian tribes, or on the distribution of power and responsibilities between the Federal Government and Indian tribes.

E. Unfunded Mandates Reform Act

The Unfunded Mandates Reform Act of 1995 (2 U.S.C. 1531-1538) requires Federal agencies to assess the effects of their discretionary regulatory actions. In particular, the Act addresses actions that may result in the expenditure by a State, local, or tribal government, in the aggregate, or by the private sector of

\$100,000,000 (adjusted for inflation) or more in any one year. Though this rule will not result in such an expenditure, we do discuss the effects of this rule elsewhere in this preamble.

F. Environment

We have analyzed this rule under Department of Homeland Security Management Directive 023-01, Rev. 1, associated implementing instructions, and Environmental Planning Policy COMDTINST 5090.1 (series) which guide the Coast Guard in complying with the National Environmental Policy Act of 1969 (NEPA) (42 U.S.C. 4321-4370f). The Coast Guard has determined that this action is one of a category of actions that do not individually or cumulatively have a significant effect on the human environment. This rule promulgates the operating regulations or procedures for drawbridges and is categorically excluded from further review, under paragraph L49, of Chapter 3, Table 3-1 of the U.S. Coast Guard Environmental Planning Implementation Procedures.

Neither a Record of Environmental Consideration nor a Memorandum for the Record are required for this rule.

List of Subjects in 33 CFR Part 117

Bridges.

For the reasons discussed in the preamble, the Coast Guard amends 33 CFR part 117 as follows:

PART 117—DRAWBRIDGE OPERATION REGULATIONS

■ 1. The authority citation for part 117 continues to read as follows:

Authority: 33 U.S.C. 499; 33 CFR 1.05-1; and DHS Delegation No. 00170.1, Revision No. 01.3.

■ 2. Stay § 117.183 until 5 p.m. on May 31, 2024.

■ 3. Add § 117.T184 to read as follows:

§ 117.T184 Old River.

The draw of the California Department of Transportation (Route 4) highway bridge, mile 14.8 between Victoria Island and Byron Tract need not be opened for the passage of vessels.

Dated: March 5, 2024.

Andrew M. Sugimoto,

Rear Admiral, U.S. Coast Guard, Commander, Eleventh Coast Guard District.

[FR Doc. 2024-05007 Filed 3-7-24; 8:45 am]

BILLING CODE 9110-04-P

DEPARTMENT OF HOMELAND SECURITY

Coast Guard

33 CFR Part 117

[Docket No. USCG-2023-0186]

RIN 1625-AA09

Drawbridge Operation Regulation; Portage River, Port Clinton, OH

AGENCY: Coast Guard, Department of Homeland Security (DHS).

ACTION: Final rule.

SUMMARY: The Coast Guard is altering operating regulations of the Monroe Street Highway Bridge, mile 0.4 and the Norfolk Southern Railroad Bridge, mile 1.5, over the Portage River at Port Clinton, Ohio.

DATES: This rule is effective April 8, 2024.

ADDRESSES: You may submit comments identified by docket number USCG-2023-0186 using Federal Decision-Making Portal at <https://www.regulations.gov>.

See the "Public Participation and Request for Comments" portion of the **SUPPLEMENTARY INFORMATION** section below for instructions on submitting comments.

FOR FURTHER INFORMATION CONTACT: If you have questions on this final rule, call or email Mr. Lee D. Soule, Bridge Management Specialist, Ninth Coast Guard District; telephone 216-902-6085, email Lee.D.Soule@uscg.mil.

SUPPLEMENTARY INFORMATION:

I. Table of Abbreviations

CFR Code of Federal Regulations
 DHS Department of Homeland Security
 FR Federal Register
 IGLD International Great Lakes Datum of 1985
 LWD Low Water Datum based on IGLD85 MPH Miles Per Hour
 NPRM Notice of Proposed Rulemaking (Advance, Supplemental)
 OMB Office of Management and Budget § Section
 U.S.C. United States Code

II. Background Information and Regulatory History

On May 5, 2023, the Coast Guard published an NPRM, with a request for comments, entitled "Drawbridge Operation Regulation; Portage River, Port Clinton, OH" in the **Federal Register** (88 FR 29007), to seek your comments on whether the Coast Guard should consider modifying the current operating schedule to the Monroe Street Highway Bridge, mile 0.4 and the

Norfolk Southern Railroad Bridge, mile 1.5, over the Portage River at Port Clinton, Ohio. 208 comments were received during the NPRM period. The relevant comments are addressed in Section IV of this Final Rule.

The current regulation for the Portage River reads as follows:

§ 117.851 Portage River

(a) Public vessels of the United States, State or local government vessels used for public safety, vessels in distress and vessels seeking shelter from rough weather shall be passed through the draws listed in this section as soon as possible. Except as provided in paragraph (c)(1)(ii) with respect to the Monroe Street bridge, commercial vessels shall be passed through the draws of this section as soon as possible.

(b) The owners of the bridges listed in this section shall provide and keep in good legible condition two board gages painted white with black figures to indicate the vertical clearance under the closed draw at all stages of the tide. The gages shall be so placed on the bridge that they are plainly visible to operators of vessels approaching the bridge either up or downstream.

(c) The draw of the Monroe Street bridge, mile 0.4 at Port Clinton, shall open as follows:

(1) From May 1 through November 30—

(i) Between the hours of 12 midnight and 6 a.m., the draw shall open on signal.

(ii) Between the hours of 6 a.m. and 12 midnight, the draw shall open on signal. However, the draw need not open on signal during this time for recreational craft and commercial vessels licensed to carry fifteen or less passengers, or less than ten gross tons, unless in distress or seeking shelter from rough weather. For these vessels, the draw need open only from three minutes before to three minutes after the hour and half-hour.

(2) From December 1 through April 30, the draw shall open on signal if at least 24 hours' notice is given.

(d) The draw of the Norfolk Southern Bridge, Mile 1.5 at Port Clinton, is remotely operated, is required to operate a radio telephone, and shall open on signal. However, from December 1 through April 30, the draw shall open on signal if at least 24 hours' notice is given.

III. Legal Authority and Need for Rule

The Coast Guard is issuing this rule under authority 33 U.S.C. 499. The Portage River is crossed by two movable bridges. The Monroe Street Highway

Bridge, mile 0.4, is a double leaf bascule bridge that provides a horizontal clearance of 75-feet, a vertical clearance of 9-feet in the closed position, and an unlimited clearance in the open position based on Low Water Datum (LWD). The Norfolk Southern Railroad Bridge, mile 1.5, is a single leaf bascule bridge with a horizontal clearance of 109-feet, a vertical clearance of 9-feet in the closed position, and an unlimited clearance in the open position based on LWD. Norfolk Southern Railroad's bridge over the Portage River is remotely operated by the Toledo Norfolk Southern Railroad Bridge.

Numerous informal complaints and concerns from local mariners concerning the operations of the Norfolk Southern Railroad Bridge, mile 1.5 triggered a review of the operating regulations governing the bridges across Portage River.

IV. Discussion of Comments, Changes, and the Final Rule

During the rulemaking process we discovered that the Monroe Street Highway Bridge, mile 0.4, sees an average of 15,000 vessels passing through the bridge annually. In addition, an average of 3,500 vehicles transit over the bridge daily. The current regulation allows the bridge to open on signal if a 24-hour advance notice of arrival is provided by vessels during the period from November 30th through April 30th. A review of the past three years of drawtender logs indicates the bridge opens more than three times a day in April for vessels. After analyzing this data and discussing vessel and vehicle traffic levels with Ohio Department of Transportation (ODOT) and to better conform to exiting use patterns, the end date for the advance notice of arrival period for the Monroe Street Highway Bridge, mile 0.4, and the Norfolk Southern Railroad Bridge, mile 1.5, will be pushed back to March 31 and changed to a 12-hour advance notice to meet the current needs of navigation and to conform to current guidance.

Of the comments received for the Monroe Street Highway Bridge, mile 0.4, 116 concerns were raised that vessels should not have the right of way or preference to vehicular traffic. The Coast Guard is required by law to ensure that bridges across navigable waters of the United States do not unreasonably obstruct waterway traffic while providing for the reasonable needs of land traffic. The Coast Guard must also ensure actions are taken that allow the 15,000 vessels that pass through the bridge annually do so in a safe and orderly manner. To ensure vessel safety,

any schedule causing vessels to wait for a bridge opening must also provide for safe waiting areas for the number of vessels passing through the bridge. Because of this, changes to a drawbridge regulation are bound by law to minimize exceptions or provisions which may restrict waterway traffic. As a result of our review of the bridge drawtender logs, the Coast Guard discovered, on average, less than four openings occurred between 6 p.m. to 6 a.m. each day. Accordingly, the Coast Guard intends to maintain hourly and half hour openings from 6 a.m. to 6 p.m. to ease the movement of vehicles. In advance of a special event, the City or State may in request to modify the drawbridge operations temporally to accommodate high vehicle or vessel flow associated with these events. Great Lakes ports commonly make these requests in the spring for modifications to be effective during special summer events.

Of the comments received for the Monroe Street Highway Bridge, mile 0.4, 27 expressed concerns that emergency vehicles would not be able to cross the bridge if it was open. 33 CFR 117.31 requires the drawtender to make all reasonable provisions for emergency response whether waterborne or vehicular. Informal comments from residents regarding emergency operations were responded to directly and personally by email or phone depending on how the comment was received. We also corresponded with ODOT and the Port Clinton Fire Department for their respective input on each informal inquiry.

Of the comments received for the Monroe Street Highway Bridge, mile 0.4, 8 comments were focused on a pedestrian crossing. Pedestrian crossing was established to allow pedestrians to cross from an adjacent parking lot to the boarding area for the Jet-Express Ferry. Commenters reported the crossing of pedestrians at the foot of the bridge causes vehicular traffic back-ups at the bridge and blocks emergency vehicles. The Coast Guard intends to provide these comments to ODOT for their evaluation of the crossing and the effect it has on highway transportation issues.

Of the comments received for the Monroe Street Highway Bridge, mile 0.4, only one commenter thought that the existing clearance gauges should remain. The Coast Guard does not believe the bridge needs to maintain these gauges at the bridge to alert the mariners to changes to the bridge clearance due to fluctuations in water level. Clearance gauges are required on bridges where the waterway is subject to the ebb and flow of tides, or where

water levels are altered artificially by humans through dams, locks, or other artificial works. The bridge provides a vertical clearance of nine feet in the closed position. The short-term natural fluctuations in water levels are not significant enough to require these gauges be maintained at the bridge. When recreational mariners inquired about the clearance gauges during the comment period, we responded by asking for the air draft of each commenter's vessel and for an explanation of how each commenter utilized the gauges to determine if they needed a bridge opening. Each commenter operating a power-driven recreational vessel responded that they did not know the height (air draft) of their vessel. Although 33 CFR 117.11 states that no vessel owner or operator shall signal a drawbridge to open after all lowerable appurtenances that are not essential to navigation have been lowered to safely pass under the bridge (stepping the mast), every sailing vessel stated the height of their vessel required an opening regardless of the water level.

Of the comments received for the Monroe Street Highway Bridge, mile 0.4, 3 comments stated crime would increase if the bridge changed to an on-demand signal from scheduled openings. No additional information or documentation was provided to support these assertions.

Of the comments received for the Monroe Street Highway Bridge, mile 0.4, 25 comments stated the bridge has always been operated in the existing manner and should not be changed. No documentation to support this alleged historical factor other justification was provided by any commenter.

Of the comments received for the Monroe Street Highway Bridge, mile 0.4, 15 commentors cited public convenience as justification not to change the schedule. These comments did not provide any supporting documentation for their views.

Of the comments received for the Monroe Street Highway Bridge, mile 0.4, 2 comments were received concerning the potential for remote operation of the bridge. The potential authorization of remote operation of the Monroe Street Highway Bridge is not part of this rulemaking.

Of the comments received for the Monroe Street Highway Bridge, mile 0.4, 3 commentors thought winter hours ended on April 1 because ODOT has manned the bridge starting on April 1 instead of May 1 due to the increase in requests for bridge openings during that period. As a result, we are moving the end date of the regulation from May 1 to April 1. We also received comments

from Ottawa County and the State of Ohio that the regulation should be left as-is. No data to support this was provided by either office. The City of Port Clinton Legal office also questioned the legality of the federal government's jurisdiction over a federal waterway of the United States. The city did not reply to numerous phone calls and emails from the Coast Guard in response to this comment. Several informal questions were also received by telephone from citizens regarding this regulation. We took the opportunity to answer any questions they may have had and invited each caller to leave a formal comment on the docket's website.

One comment was left by Norfolk Southern Railroad addressed of Norfolk Southern's practice of parking a train on the bridge at mile 3.5 to act as a wind blocker. The wind blocker action proposed in the NPRM was intended to reflect current practices of the railroad by creating a permanent deviation to the regulations which would allow Norfolk Southern to use a wind blocker without advanced authorization permission from the District Commander. Norfolk Southern's comments requested that the wind blocker provision not become part of the regulation. Because it will not be included in part B of 33 CFR 117, in advance of a significant weather event, the railroad will need to request a deviation in writing, to place a wind blocker on the bridge as required in 33 CFR 117.35. While the Coast Guard does not dispute Norfolk Southern's comment that high winds can present safety issues regarding railroad operations, expedient notification to the Coast Guard in accordance with 33 CFR 117.35 of the potential employment of a wind blocker ensures safe operations while avoiding unreasonable delays to marine traffic.

Lastly, Norfolk Southern claims the Coast Guard's regulation of bridges under the Rivers and Harbors Appropriations Act, of 1899 and subsequent laws presents a safety hazard to rail traffic. Congress' mandate to ensure the safety and efficiency of interstate commerce on the waterways is clear and is not mutually exclusive to the safe operation and efficiency of rail traffic.

V. Regulatory Analyses

We developed this rule after considering numerous statutes and Executive orders related to rulemaking. Below we summarize our analyses based on a number of these statutes and Executive orders.

A. Regulatory Planning and Review

Executive Orders 12866 and 13563 direct agencies to assess the costs and benefits of available regulatory alternatives and, if regulation is necessary, to select regulatory approaches that maximize net benefits. This proposed rule has not been designated a "significant regulatory action," under section 3(f) of Executive Order 12866, as amended by Executive Order 14094 (Modernizing Regulatory Review). This rule has not been designated a "significant regulatory action," under Executive Order 12866. Accordingly, it has not been reviewed by the Office of Management and Budget (OMB).

This regulatory action determination is based on the ability that vessels can still transit the bridge given advanced notice or that the bridge will open on a schedule.

B. Impact on Small Entities

The Regulatory Flexibility Act of 1980 (RFA), 5 U.S.C. 601–612, as amended, requires federal agencies to consider the potential impact of regulations on small entities during rulemaking. The term "small entities" comprises small businesses, not-for-profit organizations that are independently owned and operated and are not dominant in their fields, and governmental jurisdictions with populations of less than 50,000. The Coast Guard did not receive any comments from the Small Business Administration on this rule. The Coast Guard certifies under 5 U.S.C. 605(b) that this rule will not have a significant economic impact on a substantial number of small entities.

While some owners or operators of vessels intending to transit the bridge may be small entities, for the reasons stated in section V. A above, this rule will not have a significant economic impact on any vessel owner or operator.

Under section 213(a) of the Small Business Regulatory Enforcement Fairness Act of 1996 (Pub. L. 104–121), we want to assist small entities in understanding this rule. If the rule would affect your small business, organization, or governmental jurisdiction and you have questions concerning its provisions or options for compliance, please contact the person listed in the **FOR FURTHER INFORMATION CONTACT** section.

Small businesses may send comments on the actions of Federal employees who enforce, or otherwise determine compliance with, Federal regulations to the Small Business and Agriculture Regulatory Enforcement Ombudsman and the Regional Small Business

Regulatory Fairness Boards. The Ombudsman evaluates these actions annually and rates each agency's responsiveness to small business. If you wish to comment on actions by employees of the Coast Guard, call 1-888-REG-FAIR (1-888-734-3247). The Coast Guard will not retaliate against small entities that question or complain about this rule or any policy or action of the Coast Guard.

C. Collection of Information

This rule calls for no new collection of information under the Paperwork Reduction Act of 1995 (44 U.S.C. 3501-3520).

D. Federalism and Indian Tribal Government

A rule has implications for federalism under Executive Order 13132, Federalism, if it has a substantial direct effect on the States, on the relationship between the National Government and the States, or on the distribution of power and responsibilities among the various levels of government. We have analyzed this rule under that order and have determined that it is consistent with the fundamental federalism principles and preemption requirements described in Executive Order 13132.

Also, this rule does not have tribal implications under Executive Order 13175, Consultation and Coordination with Indian Tribal Governments, because it does not have a substantial direct effect on one or more Indian tribes, on the relationship between the Federal Government and Indian tribes, or on the distribution of power and responsibilities between the Federal Government and Indian tribes.

E. Unfunded Mandates Reform Act

The Unfunded Mandates Reform Act of 1995 (2 U.S.C. 1531-1538) requires Federal agencies to assess the effects of their discretionary regulatory actions. In particular, the Act addresses actions that may result in the expenditure by a State, local, or tribal government, in the aggregate, or by the private sector of \$100,000,000 (adjusted for inflation) or more in any one year. Though this rule will not result in such an expenditure, we do discuss the effects of this rule elsewhere in this preamble.

F. Environment

We have analyzed this rule under Department of Homeland Security Management Directive 023-01, Rev.1, associated implementing instructions, and Environmental Planning Policy COMDTINST 5090.1 (series) which guide the Coast Guard in complying with the National Environmental Policy

Act of 1969 (NEPA) (42 U.S.C. 4321-4370f). The Coast Guard has determined that this action is one of a category of actions that do not individually or cumulatively have a significant effect on the human environment. This rule promulgates the operating regulations or procedures for drawbridges and is categorically excluded from further review, under paragraph L49, of Chapter 3, Table 3-1 of the U.S. Coast Guard Environmental Planning Implementation Procedures.

Neither a Record of Environmental Consideration nor a Memorandum for the Record are required for this rule.

List of Subjects in 33 CFR Part 117

Bridges.

For the reasons discussed in the preamble, the Coast Guard amends 33 CFR part 117 as follows:

PART 117—DRAWBRIDGE OPERATION REGULATIONS

■ 1. The authority citation for part 117 continues to read as follows:

Authority: 33 U.S.C. 499; 33 CFR 1.05-1; and DHS Delegation No. 00170.1, Revision No. 01.3.

■ 2. Revise § 117.851 to read as follows:

§ 117.851 Portage River.

(a) The draw of the Monroe Street bridge, mile 0.4 at Port Clinton, shall open as follows:

(1) From April 1 through November 30—

(i) Between the hours of 6 p.m. and 6 a.m., the draw shall open on signal.

(ii) Between the hours of 6 a.m. and 6 p.m., the draw shall open on signal. However, the draw need not open on signal during this time for recreational craft and commercial vessels licensed to carry six or less passengers. For these vessels, the draw need open only from five minutes before to five minutes after the hour and half-hour.

(2) From December 1 through March 31, the draw shall open on signal if at least 12 hours' notice is given.

(b) The draw of the Norfolk Southern Bridge, Mile 1.5 at Port Clinton, is remotely operated, is required to operate a radio telephone, and operate and answer a telephone, and shall open on signal. Except, from December 1 through March 31, the draw shall open on signal if at least 12-hours' notice is given.

Dated: March 4, 2024.

Jonathan Hickey,

Rear Admiral, U.S. Coast Guard, Commander, Ninth Coast Guard District.

[FR Doc. 2024-04952 Filed 3-7-24; 8:45 am]

BILLING CODE 9110-04-P

DEPARTMENT OF HOMELAND SECURITY

Coast Guard

33 CFR Part 165

[Docket Number USCG-2022-0962]

RIN 1625-AA11

Regulated Navigation Area; Tampa Bay, Tampa, FL

AGENCY: Coast Guard, Department of Homeland Security (DHS).

ACTION: Final rule.

SUMMARY: The Coast Guard is revising existing regulations for a Regulated Navigation Area in Tampa Bay, Florida by updating the geographic boundaries of Egmont Channel in the Gulf of Mexico. The change is designed to align the coordinates in the regulation with the coordinates needed to properly control traffic in the Captain of the Port St. Petersburg Zone. The current coordinates do not reflect the Regulated Navigation Area that the Coast Guard intended to put in place.

DATES: This rule is effective April 8, 2024.

ADDRESSES: To view documents mentioned in this preamble as being available in the docket, go to <https://www.regulations.gov>, type USCG-2022-0962 in the search box and click "Search." Next, in the Document Type column, select "Supporting & Related Material."

FOR FURTHER INFORMATION CONTACT: If you have questions about this rule, call or email Marine Science Technician First Class Mara J. Brown, Sector St. Petersburg Prevention Department, Coast Guard; telephone (813) 228-2191, email Mara.J.Brown@uscg.mil.

SUPPLEMENTARY INFORMATION:

I. Table of Abbreviations

CFR Code of Federal Regulations
COTP Captain of the Port
DHS Department of Homeland Security
FR Federal Register
NPRM Notice of proposed rulemaking
RNA Regulated Navigation Area
§ Section
U.S.C. United States Code

II. Background Information and Regulatory History

On July 27, 2015, the Coast Guard published a final rule entitled, "Navigation and Navigable Waters; Technical, Organizational, and Conforming Amendments."¹ This

¹ 80 FR 44274.

action was taken to make non-substantive technical, organizational, and conforming amendments to existing regulations throughout Title 33 of the Code of Federal Regulations.

In 2022, it was brought to the attention of Coast Guard that there was an error in the coordinates listed in that Final Rule and that the second coordinate was off by approximately four degrees of longitude, which equates to approximately 200 nautical miles. After reviewing the coordinates and past **Federal Registers**, the approximate position of the Tampa Bay Entrance should be 27°35.2' N, 083°00.4' W.

On March 20, 2023, a Notice of Proposed Rulemaking was published in the **Federal Register** that proposed modifying the coordinates to align with the actual coordinates that are needed to indicate the entrance to Tampa Bay.² The proposed rule did not receive any comments. With this rule, the Coast Guard is correcting the coordinates needed by the COTP to ensure safety amongst port users and those navigating to and from Tampa Bay.

III. Legal Authority and Need for Rule

The Coast Guard is issuing this rule under authority in 46 U.S.C. 70034. The purpose of this rule is to correct the coordinates needed by the COTP to ensure safety amongst port users and those navigating to and from Tampa Bay.

IV. Discussion of Comments, Changes, and the Rule

As noted above, we received no comments on our NPRM published March 20, 2023. There are no changes in the regulatory text of this rule from the proposed rule in the NPRM.

This rule is modifying 33 CFR 165.753(a) to reflect the actual geographic position of the port entrance. The rule is moving the current plotted position for the regulated navigation area (RNA) to the actual plotted position of 27°35.2' N, 083°00.4' W.

V. Regulatory Analyses

We developed this rule after considering numerous statutes and Executive orders related to rulemaking. Below we summarize our analyses based on a number of these statutes and Executive orders.

A. Regulatory Planning and Review

Executive Orders 12866 and 13563 direct agencies to assess the costs and benefits of available regulatory alternatives and, if regulation is necessary, to select regulatory

approaches that maximize net benefits. This rule has not been designated a “significant regulatory action,” under section 3(f) of Executive Order 12866, as amended by Executive Order 14094 (Modernizing Regulatory Review). Accordingly, this rule has not been reviewed by the Office of Management and Budget (OMB).

This regulatory action determination is based on two specific factors: (1) persons and vessels may operate within the RNA when authorized by Captain of the Port of St. Petersburg or a designated representative; and (2) the RNA is already in place, this regulatory action only represents a correction of an error in the boundaries.

B. Impact on Small Entities

The Regulatory Flexibility Act of 1980, 5 U.S.C. 601–612, as amended, requires Federal agencies to consider the potential impact of regulations on small entities during rulemaking. The term “small entities” comprises small businesses, not-for-profit organizations that are independently owned and operated and are not dominant in their fields, and governmental jurisdictions with populations of less than 50,000. The Coast Guard received no comments from the Small Business Administration on this rulemaking. The Coast Guard certifies under 5 U.S.C. 605(b) that this rule will not have a significant economic impact on a substantial number of small entities.

While some owners or operators of vessels intending to transit the Regulated Navigation Area may be small entities, for the reasons stated in section V.A above, this rule will not have a significant economic impact on any vessel owner or operator.

Under section 213(a) of the Small Business Regulatory Enforcement Fairness Act of 1996 (Pub. L. 104–121), we want to assist small entities in understanding this rule. If the rule would affect your small business, organization, or governmental jurisdiction and you have questions concerning its provisions or options for compliance, please call or email the person listed in the **FOR FURTHER INFORMATION CONTACT** section.

Small businesses may send comments on the actions of Federal employees who enforce, or otherwise determine compliance with, Federal regulations to the Small Business and Agriculture Regulatory Enforcement Ombudsman and the Regional Small Business Regulatory Fairness Boards. The Ombudsman evaluates these actions annually and rates each agency’s responsiveness to small business. If you wish to comment on actions by

employees of the Coast Guard, call 1–888–REG–FAIR (1–888–734–3247). The Coast Guard will not retaliate against small entities that question or complain about this rule or any policy or action of the Coast Guard.

C. Collection of Information

This rule will not call for a new collection of information under the Paperwork Reduction Act of 1995 (44 U.S.C. 3501–3520).

D. Federalism and Indian Tribal Governments

A rule has implications for federalism under Executive Order 13132, Federalism, if it has a substantial direct effect on the States, on the relationship between the National Government and the States, or on the distribution of power and responsibilities among the various levels of government. We have analyzed this rule under that order and have determined that it is consistent with the fundamental federalism principles and preemption requirements described in Executive Order 13132.

Also, this rule does not have tribal implications under Executive Order 13175, Consultation and Coordination with Indian Tribal Governments, because it does not have a substantial direct effect on one or more Indian tribes, on the relationship between the Federal Government and Indian tribes, or on the distribution of power and responsibilities between the Federal Government and Indian tribes.

E. Unfunded Mandates Reform Act

The Unfunded Mandates Reform Act of 1995 (2 U.S.C. 1531–1538) requires Federal agencies to assess the effects of their discretionary regulatory actions. In particular, the Act addresses actions that may result in the expenditure by a State, local, or tribal government, in the aggregate, or by the private sector of \$100,000,000 (adjusted for inflation) or more in any one year. Though this rule will not result in such an expenditure, we do discuss the effects of this rule elsewhere in this preamble.

F. Environment

We have analyzed this rule under Department of Homeland Security Directive 023–01, Rev. 1, associated implementing instructions, and Environmental Planning COMDTINST 5090.1 (series), which guide the Coast Guard in complying with the National Environmental Policy Act of 1969 (42 U.S.C. 4321–4370f), and have determined that this action is one of a category of actions that do not individually or cumulatively have a significant effect on the human

² 88 FR 16576.

environment. This proposed rule involves a correction of a geographic coordinate identifying the entrance Bouy for Tampa Bay. Normally such actions are categorically excluded from further review under paragraph L60a of Appendix A, Table 1 of DHS Instruction Manual 023-01-001-01, Rev. 1. A Record of Environmental Consideration supporting this determination is available in the docket. For instructions on locating the docket, see the ADDRESSES section of this preamble. We seek any comments or information that may lead to the discovery of a significant environmental impact from this proposed rule.

List of Subjects in 33 CFR Part 165

Harbors, Marine safety, Navigation (water), Reporting and recordkeeping requirements, Security measures, Waterways.

For the reasons discussed in the preamble, the Coast Guard amends 33 CFR part 165 as follows:

PART 165—REGULATED NAVIGATION AREAS AND LIMITED ACCESS AREAS

- 1. The authority citation for part 165 continues to read as follows:

Authority: 46 U.S.C. 70034, 70051, 70124; 33 CFR 1.05-1, 6.04-1, 6.04-6, and 160.5; Department of Homeland Security Delegation No. 00170.1, Revision No. 01.3.

- 2. In § 165.753, revise paragraph (a) to read as follows:

§ 165.753 Regulated navigation area; Tampa Bay, Florida.

(a) The following is a regulated navigation area (RNA): All the navigable waters of Tampa Bay, Hillsborough Bay and Old Tampa Bay, including all navigable waterways tributary thereto. Also included are the waters of Egmont Channel, Gulf of Mexico from Tampa Bay, Tampa Bay Entrance, approximate position (27°35.2' N, 083°00.4' W).

* * * * *

Dated: March 1, 2024.

Michael P. Kahle,

Captain, U.S. Coast Guard, Captain of the Port Sector St. Petersburg.

[FR Doc. 2024-05008 Filed 3-7-24; 8:45 am]

BILLING CODE 9110-04-P

DEPARTMENT OF HOMELAND SECURITY

Coast Guard

33 CFR Part 165

[Docket Number USCG-2024-0166]

RIN 1625-AA00

Safety Zone; St. Petersburg, Florida

AGENCY: Coast Guard, Department of Homeland Security (DHS).

ACTION: Temporary final rule.

SUMMARY: The Coast Guard is establishing a temporary safety zone for navigable waters of Tampa Bay, in the vicinity of the St. Petersburg Municipal Yacht Basin, during a racing event in St. Petersburg, FL. The safety zone is necessary to ensure the safety of participant vessels, spectators, and the general public during the event. Entry of vessels or persons into this zone is prohibited unless specifically authorized by the Captain of the Port St. Petersburg or a designated representative.

DATES: This rule is effective daily from 6 a.m. until 10 p.m., on March 7, 2024, through March 10, 2024.

ADDRESSES: To view documents mentioned in this preamble as being available in the docket, go to <https://www.regulations.gov>, type USCG-2024-0166 in the search box and click "Search." Next, in the Document Type column, select "Supporting & Related Material."

FOR FURTHER INFORMATION CONTACT: If you have questions on this rule, call or email Marine Science Technician First Class Mara Brown, Sector St. Petersburg Prevention Department, U.S. Coast Guard; telephone (813) 228-2191, email Mara.J.Brown@uscg.mil.

SUPPLEMENTARY INFORMATION:

I. Table of Abbreviations

CFR Code of Federal Regulations
DHS Department of Homeland Security
FR Federal Register
NPRM Notice of proposed rulemaking
§ Section
U.S.C. United States Code

II. Background, Purpose, and Regulatory History

The Coast Guard is issuing this temporary rule without prior notice and opportunity to comment pursuant to authority under section 4(a) of the Administrative Procedure Act (APA) (5 U.S.C. 553(b)). This provision authorizes an agency to issue a rule without prior notice and opportunity to comment when the agency for good

cause finds that those procedures are "impracticable, unnecessary, or contrary to the public interest." Under 5 U.S.C. 553(b)(B), the Coast Guard finds that good cause exists for not publishing a notice of proposed rulemaking (NPRM) with respect to this rule because it is impracticable and contrary to public interest. The Coast Guard did not receive notice that a safety zone would be part of the pre-scheduled Firestone Grand Prix race event until February 15, 2024. This action is necessary for the protection of life and property on the navigable waters of the United States. The event would begin before the rulemaking process would be completed. It is impracticable to publish an NPRM because we must establish this safety zone by March 7, 2024.

Under 5 U.S.C. 553(d)(3), the Coast Guard finds that good cause exists for making this rule effective less than 30 days after publication in the **Federal Register**. It is impracticable and contrary to the public interest to delay this rule because it is necessary to protect spectators, vessels, and the marine environment from potential hazards created by the race event.

III. Legal Authority and Need for Rule

The Coast Guard is issuing this rule under authority in 46 U.S.C. 70034. The Captain of the Port St. Petersburg (COTP) has determined that potential hazards associated with the race event near St. Petersburg Municipal Yacht Basin. This rule is necessary to ensure the safety of the spectators, the general public, vessels and the navigable waters of St. Petersburg, FL, during the race event.

IV. Discussion of the Rule

This rule establishes a safety zone on certain waters near the Municipal Yacht Basin in St. Petersburg, FL, during the Firestone Grand Prix race event in St. Petersburg, FL. This safety zone will be enforced from 6 a.m. until 10 p.m., daily on March 7, 2024 through March 10, 2024. The safety zone will cover all navigable waters within a specified area of Tampa Bay, during the race event. The safety zone is needed to protect the public, vessels, and the marine environment from potential hazards created by spectators of the race event. No person or vessel will be permitted to enter, transit through, anchor in, or remain within the safety zone without obtaining permission from the COTP or a designated representative. If authorization to enter, transit through, anchor in, or remain within the safety zone is granted by the COTP or a designated representative, all persons and vessels receiving such authorization

must comply with the instructions of the COTP or a designated representative. The Coast Guard will provide notice of the safety zone by Broadcast Notice to Mariners, and/or by on-scene designated representatives.

V. Regulatory Analyses

We developed this rule after considering numerous statutes and Executive orders related to rulemaking. Below we summarize our analyses based on a number of these statutes and Executive orders, and we discuss First Amendment rights of protesters.

A. Regulatory Planning and Review

Executive Orders 12866 and 13563 direct agencies to assess the costs and benefits of available regulatory alternatives and, if regulation is necessary, to select regulatory approaches that maximize net benefits. This rule has not been designated a “significant regulatory action,” under section 3(f) of Executive Order 12866, as amended by Executive Order 14094 (Modernizing Regulatory Review). Accordingly, this rule has not been reviewed by the Office of Management and Budget (OMB).

This regulatory action determination is based on the, location, duration, and scope of the safety zone. This rule involves a safety zone that will prohibit persons and vessels from entering, transiting through, anchoring in, or remaining within certain waters around Municipal Yacht Basin, in St. Petersburg, FL during the Firestone Grand Prix of St. Petersburg race event lasting four days.

Although persons and vessels may not enter, transit through, anchor in, or remain within the safety zone without authorization from the COTP or a designated representative, they will be able to safely transit around the zone. Moreover, the Coast Guard would issue a Broadcast Notice to Mariners via VHF-FM marine channel 16 about the zone, and the rule would allow vessels to seek permission to enter the safety zone.

B. Impact on Small Entities

The Regulatory Flexibility Act of 1980, 5 U.S.C. 601–612, as amended, requires Federal agencies to consider the potential impact of regulations on small entities during rulemaking. The term “small entities” comprises small businesses, not-for-profit organizations that are independently owned and operated and are not dominant in their fields, and governmental jurisdictions with populations of less than 50,000. The Coast Guard certifies under 5 U.S.C. 605(b) that this rule would not have a

significant economic impact on a substantial number of small entities.

While some owners or operators of vessels intending to transit the safety zone may be small entities, for the reasons stated in section V.A above, this rule will not have a significant economic impact on any vessel owner or operator.

Under section 213(a) of the Small Business Regulatory Enforcement Fairness Act of 1996 (Pub. L. 104–121), we want to assist small entities in understanding this rule. If the rule would affect your small business, organization, or governmental jurisdiction and you have questions concerning its provisions or options for compliance, please contact the person listed in the **FOR FURTHER INFORMATION CONTACT** section.

Small businesses may send comments on the actions of Federal employees who enforce, or otherwise determine compliance with, Federal regulations to the Small Business and Agriculture Regulatory Enforcement Ombudsman and the Regional Small Business Regulatory Fairness Boards. The Ombudsman evaluates these actions annually and rates each agency’s responsiveness to small business. If you wish to comment on actions by employees of the Coast Guard, call 1–888-REG-FAIR (1–888-734-3247). The Coast Guard will not retaliate against small entities that question or complain about this rule or any policy or action of the Coast Guard.

C. Collection of Information

This rule will not call for a new collection of information under the Paperwork Reduction Act of 1995 (44 U.S.C. 3501–3520).

D. Federalism and Indian Tribal Governments

A rule has implications for federalism under Executive Order 13132, Federalism, if it has a substantial direct effect on the States, on the relationship between the National Government and the States, or on the distribution of power and responsibilities among the various levels of government. We have analyzed this rule under that order and have determined that it is consistent with the fundamental federalism principles and preemption requirements described in Executive Order 13132.

Also, this rule does not have tribal implications under Executive Order 13175, Consultation and Coordination with Indian Tribal Governments, because it does not have a substantial direct effect on one or more Indian tribes, on the relationship between the Federal Government and Indian tribes,

or on the distribution of power and responsibilities between the Federal Government and Indian tribes.

E. Unfunded Mandates Reform Act

The Unfunded Mandates Reform Act of 1995 (2 U.S.C. 1531–1538) requires Federal agencies to assess the effects of their discretionary regulatory actions. In particular, the Act addresses actions that may result in the expenditure by a State, local, or tribal government, in the aggregate, or by the private sector of \$100,000,000 (adjusted for inflation) or more in any one year. Though this rule will not result in such an expenditure, we do discuss the effects of this rule elsewhere in this preamble.

F. Environment

We have analyzed this rule under Department of Homeland Security Directive 023–01, Rev. 1, associated implementing instructions, and Environmental Planning COMDTINST 5090.1 (series), which guide the Coast Guard in complying with the National Environmental Policy Act of 1969 (42 U.S.C. 4321–4370f), and have determined that this action is one of a category of actions that do not individually or cumulatively have a significant effect on the human environment. This rule involves a safety zone that will prohibit persons and vessels from entering, transiting through, anchoring in, or remaining within within certain waters around Municipal Yacht Basin, in St. Petersburg, FL during the Firestone Grand Prix of St. Petersburg race event lasting four days. It is categorically excluded from further review under paragraph L60(a) of Appendix A, Table 1 of DHS Instruction Manual 023–01–001–01, Rev. 1. A Record of Environmental Consideration supporting this determination is available in the docket. For instructions on locating the docket, see the **ADDRESSES** section of this preamble.

G. Protest Activities

The Coast Guard respects the First Amendment rights of protesters. Protesters are asked to call or email the person listed in the **FOR FURTHER INFORMATION CONTACT** section to coordinate protest activities so that your message can be received without jeopardizing the safety or security of people, places, or vessels.

List of Subjects in 33 CFR Part 165

Harbors, Marine safety, Navigation (water), Reporting and recordkeeping requirements, Security measures, Waterways.

For the reasons discussed in the preamble, the Coast Guard amends 33 CFR part 165 as follows:

PART 165—REGULATED NAVIGATION AREAS AND LIMITED ACCESS AREAS

■ 1. The authority citation for part 165 continues to read as follows:

Authority: 46 U.S.C. 70034, 70051, 70124; 33 CFR 1.05–1, 6.04–1, 6.04–6, and 160.5; Department of Homeland Security Delegation No. 00170.1, Revision No. 01.3.

■ 2. Add § 165.T07–0166 to read as follows:

§ 165.T07–0166 Safety Zone; Firestone Grand Prix of St. Petersburg, St. Petersburg, FL.

(a) *Location.* The following area is a safety zone. All waters of Tampa Bay encompassed within the following points: 27°46′18″ N, 082°37′55.2″ W, thence to position 27°46′18″ N, 082°37′54.6″ W, thence to position 27°46′9.6″ N, 082°37′54.6″ W, thence to position 27°46′9.6″ N, 082°37′33″ W, thence to position 27°46′4.2″ N, 082°37′33″ W, thence to position 27°45′59.4″ N, 082°37′50.4″ W, thence to position 27°46′6.6″ N, 082°37′56.4″ W, thence to position 27°46′13.8″ N, 082°37′55.8″ W, thence back to the original position 27°46′18″ N, 082°37′55.2″ W. All coordinates are North American Datum 1983.

(b) *Definitions.* As used in this section, “*designated representative*” means a Coast Guard Patrol Commander, including a Coast Guard coxswain, petty officer, or other officer operating a Coast Guard vessel and a Federal, State, and local officer designated by or assisting the Captain of the Port St. Petersburg (COTP) in the enforcement of the safety zone.

(c) *Regulations.*

(1) All persons and vessels are prohibited from entering, transiting through, anchoring in, or remaining within the regulated area unless authorized by the COTP or a designated representative.

(2) Persons and vessels desiring to enter, transit through, anchor in, or remain within the regulated area may contact the COTP by telephone at 727–824–7506, or a designated representative via VHF–FM radio on channel 16 to request authorization. If authorization is granted, all persons and vessels receiving such authorization must comply with the instructions of the COTP St. Petersburg or a designated representative.

(3) The Coast Guard will provide notice of the regulated area by Broadcast Notice to Mariners via VHF–FM channel

16, and/or by on-scene designated representatives.

(d) *Enforcement Period.* This rule will be enforced daily from 6 a.m. until 10 p.m., on March 7, 2024, through March 10, 2024.

Dated: March 1, 2024.

Michael P. Kahle,

Captain, U.S. Coast Guard, Captain of the Port Saint Petersburg.

[FR Doc. 2024–04951 Filed 3–7–24; 8:45 am]

BILLING CODE 9110–04–P

NATIONAL ARCHIVES AND RECORDS ADMINISTRATION

36 CFR Part 1202

[FDMS No. NARA–24–0004; NARA–2024–017]

RIN 3095–AC21

Making a Privacy Act Request

AGENCY: National Archives and Records Administration (NARA).

ACTION: Direct final rule.

SUMMARY: The National Archives and Records Administration (NARA) is amending our regulations on the Privacy Act to allow individuals to submit electronic Privacy Act requests.

DATES: This rule is effective April 17, 2024, without further action, unless we receive actionable adverse comments by March 28, 2024. If we receive such comments, we will publish a withdrawal of the rule in the **Federal Register**.

ADDRESSES: You may submit comments, identified by RIN 3095–AC21 by the following method:

- *Federal eRulemaking Portal:* Go to <https://www.regulations.gov>. Follow the online instructions for submitting comments. All submissions must include NARA’s name and the regulatory information number for this rule (RIN 3095–AC21). We may publish any comments we receive without changes, including any personal information you include.

- Mail (for paper, flash drive, or CD–ROM submissions. Include “RIN 3095–AC21” on the submission): National Archives and Records Administration; Regulation Comments Desk, Suite 4100; 8601 Adelphi Road; College Park, MD 20740–6001.

FOR FURTHER INFORMATION CONTACT: Kimberly Richardson, Strategy and Performance Division, by email at regulation_comments@nara.gov, by email at kimberly.richardson@nara.gov, or by phone at 301–837–2902. Contact privacy@nara.gov with any questions on NARA’s privacy program.

SUPPLEMENTARY INFORMATION: The National Archives and Records Administration (NARA) is amending our regulations to allow individuals to submit electronic Privacy Act requests. The revision will incorporate the requirements of the CASES Act and OMB Memo M–21–04. These authorities require agencies to provide a digital service option for individuals to make a digital Privacy Act request. The revised regulation will describe how individuals can make a digital Privacy Act request through NARA’s website.

Regulatory Analysis

Review Under Executive Order 12866, Regulatory Planning and Review, 58 FR 51735; Executive Order 13563, Improving Regulation and Regulation Review, 76 FR 23821; and Executive Order 14094, Modernizing Regulatory Review, 88 FR 21879

The Office of Management and Budget (OMB) has reviewed this rule and determined it is not “significant” under section 3(f) of Executive Order 12866. It is not significant because it consists of administrative and minor revisions, involves agency organization and management, does not change substantive requirements, and imposes no costs on the public.

Review Under the Regulatory Flexibility Act (5 U.S.C. 601, et seq.)

This review requires an agency to prepare an initial regulatory flexibility analysis and publish it when the agency publishes the proposed rule. This requirement does not apply if the agency certifies that the rulemaking will not, if promulgated, have a significant economic impact on a substantial number of small entities (5 U.S.C. 603). We certify, after review and analysis, that this rule will not have a significant adverse economic impact on small entities.

Review Under the Paperwork Reduction Act of 1995 (44 U.S.C. 3501 et seq.)

This rule does not impose additional information collection requirements on the public that are subject to the Paperwork Reduction Act.

Review Under Executive Order 13132, Federalism, 64 FR 43255

Review under Executive Order 13132 requires that agencies review regulations for federalism effects on the institutional interest of states and local governments, and, if the effects are sufficiently substantial, prepare a federalism assessment to assist senior policy makers. This rule will not have any effects on state and local governments within the meaning of the

Executive order. Therefore, no federalism assessment is required.

Review Under the Unfunded Mandates Reform Act (Sec. 202, Pub. L. 104–4; 2 U.S.C. 1532)

Review under the Unfunded Mandates Reform Act requires that agencies determine whether any Federal mandate in the rulemaking may result in state, local, and tribal governments, in the aggregate, or the private sector, expending \$100 million in any one year. NARA certifies that this rule does not contain a Federal mandate that may result in such an expenditure, and this rule is therefore not subject to this requirement.

List of Subjects in 36 CFR Part 1202

Privacy.

For the reasons stated in the preamble, NARA amends 36 CFR part 1202 as follows:

PART 1202—REGULATIONS IMPLEMENTING THE PRIVACY ACT OF 1974

■ 1. The authority citation for part 1202 continues to read as follows:

Authority: 5 U.S.C. 552a; 44 U.S.C. 2104(a).

■ 2. Revise § 1202.40 to read as follows:

§ 1202.40 How can I gain access to NARA records about myself?

(a) If you wish to request access to information about yourself contained in a NARA Privacy Act system of records, you may do so in writing or electronically.

(1) Written requests must be directed to the NARA Privacy Act Officer, National Archives and Records Administration, Rm. 3110, 8601 Adelphi Rd., College Park, MD 20740–6001. Your request should be clearly marked on the letter and the envelope as a “Privacy Act Request.”

(2) Electronic requests may be initiated online at <https://www.archives.gov/privacy>.

(b) If you wish to allow another person to review or obtain a copy of your record, you must provide authorization in writing or electronically for that person to obtain access as part of your request.

(c) Your request must contain:

(1) The complete name and identifying number of the NARA system as published in the **Federal Register**;

(2) A brief description of the nature, time, place, and circumstances of your association with NARA;

(3) Any other information which you believe would help NARA to determine

whether the information about you is included in the system of records;

(4) If you are authorizing another individual to have access to your records, the name of that person; and

(5) A Privacy Act certification of identity. When you make a request for access to records about yourself, you must verify your identity.

(i) If you are submitting a written request, you must sign your request and your signature must either be notarized or submitted by you under 28 U.S.C. 1746, a law that permits statements to be made under penalty of perjury as a substitute for notarization. While no specific form is required, you may obtain a Certification of Identity form for this purpose from the NARA Privacy Act Officer. The following information is required:

(A) Your full name;

(B) An acknowledgment that you understand the criminal penalty in the Privacy Act for requesting or obtaining access to records under false pretenses (5 U.S.C. 552a(i)(3)); and

(C) A declaration that your statement is true and correct under penalty of perjury (18 U.S.C. 1001).

(ii) If you are submitting an electronic request, you must provide an electronically signed statement on the electronic form. The statement affirms your identity and the fact that you understand penalties associated with requesting information under false pretenses.

(d) The procedure for accessing an accounting of disclosure is identical to the procedure for access to a record as set forth in this section.

Colleen J. Shogan,

Archivist of the United States.

[FR Doc. 2024–04939 Filed 3–7–24; 8:45 am]

BILLING CODE 7515–01–P

ENVIRONMENTAL PROTECTION AGENCY

40 CFR Part 52

[EPA–R09–OAR–2023–0568; FRL–11558–03–R9]

Determination To Defer Sanctions; California; South Coast Air Quality Management District

AGENCY: Environmental Protection Agency (EPA).

ACTION: Interim final determination.

SUMMARY: The Environmental Protection Agency (EPA) is making an interim final determination that the California Air Resources Board (CARB) has submitted a revised rule on behalf of the South

Coast Air Quality Management District (SCAQMD) that corrects deficiencies in its Clean Air Act (CAA or Act) state implementation plan (SIP) provisions concerning ozone nonattainment requirements for controlling volatile organic compounds (VOCs) and oxides of nitrogen (NO_x) from refinery flares. This determination is based on a proposed approval, published elsewhere in this **Federal Register**, of SCAQMD Rule 1118 regulating that source category. The effect of this interim final determination is that the imposition of sanctions that were triggered by a previous disapproval by the EPA in 2022 is now deferred. If the EPA finalizes its approval of SCAQMD’s submission, relief from these sanctions will become permanent.

DATES: This rule is effective on March 8, 2024. However, comments will be accepted on or before April 8, 2024.

ADDRESSES: Submit your comments, identified by Docket ID No. EPA–R09–OAR–2023–0568 at <https://www.regulations.gov>. For comments submitted at [Regulations.gov](https://www.regulations.gov), follow the online instructions for submitting comments. Once submitted, comments cannot be edited or removed from [Regulations.gov](https://www.regulations.gov). The EPA may publish any comment received to its public docket. Do not submit electronically any information you consider to be Confidential Business Information (CBI) or other information whose disclosure is restricted by statute. Multimedia submissions (audio, video, etc.) must be accompanied by a written comment. The written comment is considered the official comment and should include discussion of all points you wish to make. The EPA will generally not consider comments or comment contents located outside of the primary submission (*i.e.*, on the web, cloud, or other file sharing system). For additional submission methods, please contact the person identified in the **FOR FURTHER INFORMATION CONTACT** section. For the full EPA public comment policy, information about CBI or multimedia submissions, and general guidance on making effective comments, please visit <https://www.epa.gov/dockets/commenting-epa-dockets>. If you need assistance in a language other than English or if you are a person with disabilities who needs a reasonable accommodation at no cost to you, please contact the person identified in the **FOR FURTHER INFORMATION CONTACT** section.

FOR FURTHER INFORMATION CONTACT: Donnique Sherman, EPA Region IX, 75 Hawthorne St., San Francisco, CA 94105. By phone: (415) 947–4129 or by email at sherman.donnique@epa.gov.

SUPPLEMENTARY INFORMATION:

Throughout this document, “we,” “us,” and “our” refer to the EPA.

Table of Contents

- I. Background
- II. The EPA’s Evaluation and Action
- III. Statutory and Executive Order Reviews

I. Background

On September 22, 2022, (87 FR 57838), the EPA issued a final limited approval and limited disapproval for the SCAQMD Rule 1118 that had been submitted by CARB to the EPA on February 16, 2018. In our 2022 action, we determined that while the SCAQMD SIP revision submittal strengthened the SIP, Section (j) of Rule 1118 allowed the Executive Officer the authority to approve another test method than those identified in the rule and without further specificity regarding how this authority will be exercised, it could functionally allow for a revision of the SIP without complying with the process for SIP revisions required by the CAA. As a result, this undermines the enforceability of the submission, constitutes a SIP deficiency, and conflicts with CAA Section 110. Pursuant to section 179 of the CAA and our regulations at 40 CFR 52.31, this limited disapproval action under title I, part D started a sanctions clock for imposition of offset sanctions 18 months after the action’s effective date of October 22, 2023, and highway sanctions 6 months later.

The District submitted an amended Rule 1118 (amended January 6, 2023), which was transmitted by CARB to the EPA on May 11, 2023, that added California Air Resources Board and the EPA as approvers of other test methods. In the Proposed Rules section of this **Federal Register**, we have proposed approval of SCAQMD’s 2023 submittal of Rule 1118. Based on this proposed approval action, we are also taking this interim final determination, effective on publication, to defer imposition of the offset sanctions and highway sanctions that were triggered by our 2022 limited disapproval of Rule 1118, because we believe that the new version corrects the deficiency that triggered such sanctions.

The EPA is providing the public with an opportunity to comment on this deferral of sanctions. If comments are submitted that change our assessment described in this interim final determination and the proposed full approval of Rule 1118, we would take final action to lift this deferral of sanctions under 40 CFR 52.31. If no comments are submitted that change our assessment, then all sanctions and any sanction clocks triggered by our 2022

action would be permanently terminated on the effective date of our final approval of Rule 1118.

II. The EPA’s Evaluation and Action

We are making an interim final determination to defer CAA section 179 sanctions associated with our limited disapproval on the 2018 submittal of Rule 1118. This determination is based on our concurrent proposal to approve the 2023 submittal of Rule 1118, which resolves the deficiency that triggered sanctions under section 179 of the CAA.

Because the EPA has preliminarily determined that new version of Rule 1118 is fully approvable, relief from sanctions should be provided as quickly as possible. Therefore, the EPA is invoking the good cause exception under the Administrative Procedure Act (APA) in not providing an opportunity for comment before this action takes effect (5 U.S.C. 553(b)(3)). However, by this action, the EPA is providing the public with a chance to comment on the EPA’s determination after the effective date, and the EPA will consider any comments received in determining whether to reverse such action.

The EPA believes that notice-and-comment rulemaking before the effective date of this action is impracticable and contrary to the public interest. The EPA has reviewed the State’s submittal and, through its proposed action, is indicating that it is more likely than not that the State has submitted a revision to the SIP that corrects deficiencies under part D of the Act that were the basis for the action that started the sanctions clocks. Therefore, it is not in the public interest to impose sanctions. The EPA believes that it is necessary to use the interim final rulemaking process to defer sanctions while the EPA completes its rulemaking process on the approvability of the State’s submittal. Moreover, with respect to the effective date of this action, the EPA is invoking the good cause exception to the 30-day notice requirement of the APA because the purpose of this notice is to relieve a restriction (5 U.S.C. 553(d)(1)).

III. Statutory and Executive Order Reviews

This action defers sanctions and imposes no additional requirements. For that reason, this action:

- Is not a “significant regulatory action” subject to review by the Office of Management and Budget under Executive Orders 12866 (58 FR 51735, October 4, 1993) and 13563 (76 FR 3821, January 21, 2011);
- Does not impose an information collection burden under the provisions

of the Paperwork Reduction Act (44 U.S.C. 3501 *et seq.*);

- Is certified as not having a significant economic impact on a substantial number of small entities under the Regulatory Flexibility Act (5 U.S.C. 601 *et seq.*);
- Does not contain any unfunded mandate or significantly or uniquely affect small governments, as described in the Unfunded Mandates Reform Act of 1995 (Pub. L. 104–4);
- Does not have federalism implications as specified in Executive Order 13132 (64 FR 43255, August 10, 1999);
- Is not an economically significant regulatory action based on health or safety risks subject to Executive Order 13045 (62 FR 19885, April 23, 1997);
- Is not a significant regulatory action subject to Executive Order 13211 (66 FR 28355, May 22, 2001);
- Is not subject to requirements of Section 12(d) of the National Technology Transfer and Advancement Act of 1995 (15 U.S.C. 272 note) because application of those requirements would be inconsistent with the Clean Air Act; and
- Does not provide the EPA with the discretionary authority to address disproportionate human health or environmental effects with practical, appropriate, and legally permissible methods under Executive Order 12898 (59 FR 7629, February 16, 1994).
- Is not approved to apply on any Indian reservation land or in any other area where the EPA or an Indian tribe has demonstrated that a tribe has jurisdiction. In those areas of Indian country, the rule does not have tribal implications and will not impose substantial direct costs on tribal governments or preempt tribal law as specified by Executive Order 13175 (65 FR 67249, November 9, 2000).
- Is subject to the Congressional Review Act (CRA), 5 U.S.C. 801 *et seq.*, and the EPA will submit a rule report to each House of the Congress and to the Comptroller General of the United States. The CRA allows the issuing agency to make a rule effective sooner than otherwise provided by the CRA if the agency makes a good cause finding that notice and comment rulemaking procedures are impracticable, unnecessary or contrary to the public interest (5 U.S.C. 808(2)). The EPA has made a good cause finding for this rule as discussed in section II of this preamble, including the basis for that finding.

Under section 307(b)(1) of the CAA, petitions for judicial review of this action must be filed in the United States Court of Appeals for the appropriate

circuit by May 7, 2024. Filing a petition for reconsideration by the EPA Administrator of this final rule does not affect the finality of this rule for the purpose of judicial review nor does it extend the time within which petition for judicial review may be filed, and shall not postpone the effectiveness of such rule or action. This action may not

be challenged later in proceedings to enforce its requirements (see CAA section 307(b)(2)).

List of Subjects in 40 CFR Part 52

Environmental protection, Air pollution control, Carbon monoxide, Incorporation by reference, Intergovernmental relations, Oxides of

nitrogen, Ozone, Volatile organic compounds, Reporting and recordkeeping requirements.

Dated: February 29, 2024.

Martha Guzman Aceves,

Regional Administrator, Region IX.

[FR Doc. 2024-04921 Filed 3-7-24; 8:45 am]

BILLING CODE 6560-50-P

Proposed Rules

Federal Register

Vol. 89, No. 47

Friday, March 8, 2024

This section of the FEDERAL REGISTER contains notices to the public of the proposed issuance of rules and regulations. The purpose of these notices is to give interested persons an opportunity to participate in the rule making prior to the adoption of the final rules.

Dated: March 4, 2024.

Deborah Papadopoulos,
Records Management Specialist, U.S. International Development Finance Corporation.

[FR Doc. 2024-04978 Filed 3-7-24; 8:45 am]

BILLING CODE 3210-02-P

INTERNATIONAL DEVELOPMENT FINANCE CORPORATION

2 CFR Chapter XVI

Nonprocurement Suspension and Debarment; Correction

AGENCY: U.S. International Development Finance Corporation.

ACTION: Proposed rule; correction.

SUMMARY: This document corrects a U.S. International Development Finance Corporation (DFC) proposed rule published in the **Federal Register** on January 5, 2024, regarding nonprocurement suspension and debarment (S&D). This correction clarifies that DFC may debar a person or entity for refusing to engage in efforts to remediate identified environmental, social, and human rights harm stemming from their activities, including harm that may be identified through a DFC Office of Accountability complaints process.

DATES: March 8, 2024.

FOR FURTHER INFORMATION CONTACT: Agency Submitting Officer: Deborah Papadopoulos, (202) 357-3979, *Email: fedreg@dfc.gov.*

SUPPLEMENTARY INFORMATION:

Correction

■ In the proposed rule FR Doc. 2023-28838, at 89 FR 716, in the issue of January 5, 2024, on page 716, in the first column, correct Subpart H—Debarment, § 1600.890 by adding paragraph (c) to read as follows:

§ 1600.890 [Corrected]

* * * * *

(c) DFC may debar a person or entity for refusing to engage in efforts to remediate identified environmental, social, and human rights harm stemming from their activities, including harm that may be identified through a DFC Office of Accountability complaints process.

* * * * *

NUCLEAR REGULATORY COMMISSION

10 CFR Part 37

[NRC-2022-0191]

RIN 3150-AK90

Advance Tribal Notification of Category 1 Quantities of Radioactive Material Shipments

AGENCY: Nuclear Regulatory Commission.

ACTION: Proposed rule.

SUMMARY: The U.S. Nuclear Regulatory Commission (NRC) is proposing to amend its regulations to require NRC and Agreement State licensees to provide advance notification to participating federally recognized Tribal governments regarding shipments of category 1 quantities of radioactive material that pass within or across their reservation boundaries. This proposed rule would resolve a petition for rulemaking (PRM-37-2) requesting changes to the regulations to include advance Tribal notification requirements similar to existing State notification requirements. The NRC will hold a public meeting during the public comment period to promote full understanding of this proposed rule and facilitate public comments.

DATES: Submit comments by May 22, 2024. Comments received after this date will be considered if it is practical to do so, but the NRC is able to ensure consideration only for comments received before this date.

ADDRESSES: You may submit comments by any of the following methods; however, the NRC encourages electronic comment submission through the Federal Rulemaking website:

• *Federal Rulemaking Website:* Go to <https://www.regulations.gov> and search for Docket ID NRC-2022-0191. Address questions about NRC dockets to Dawn Forder; telephone: 301-415-3407; email: Dawn.Forder@nrc.gov. For

technical questions contact the individuals listed in the **FOR FURTHER INFORMATION CONTACT** section of this document.

• *Email comments to:* Rulemaking.Comments@nrc.gov. If you do not receive an automatic email reply confirming receipt, then contact us at 301-415-1677.

• *Fax comments to:* Secretary, U.S. Nuclear Regulatory Commission at 301-415-1101.

• *Hand deliver comments to:* 11555 Rockville Pike, Rockville, Maryland 20852, between 7:30 a.m. and 4:15 p.m. eastern time, Federal workdays; telephone: 301-415-1677.

• *Mail comments to:* Secretary, U.S. Nuclear Regulatory Commission, Washington, DC 20555-0001, ATTN: Rulemakings and Adjudications Staff.

You can read a plain language description of this proposed rule at <https://www.regulations.gov/docket/NRC-2022-0191>. For additional direction on obtaining information and submitting comments, see “Obtaining Information and Submitting Comments” in the **SUPPLEMENTARY INFORMATION** section of this document.

FOR FURTHER INFORMATION CONTACT: Caylee Kenny, Office of Nuclear Material Safety and Safeguards, telephone: 301-415-7150, email: Caylee.Kenny@nrc.gov and Anita Gray, Office of Nuclear Material Safety and Safeguards, telephone: 301-415-7036, email: Anita.Gray@nrc.gov. Both are staff of the U.S. Nuclear Regulatory Commission, Washington, DC 20555-0001.

SUPPLEMENTARY INFORMATION:

Table of Contents

- I. Obtaining Information and Submitting Comments
 - A. Obtaining Information
 - B. Submitting Comments
- II. Background
 - A. Petition for Rulemaking (PRM-37-2)
 - B. Advance Notification Rule
 - C. Tribal Policy Statement
- III. Discussion
 - A. What action is the NRC taking?
 - B. What persons would this action affect?
 - C. Why do the requirements need to be revised?
 - D. Would all tribes receive advance notifications?
 - E. How and when would tribes be given the option to receive advance notifications?
 - F. What notifications would tribes receive?

- G. Do tribes who currently receive notifications under parts 71 and 73 need to take additional action?
- H. Does a tribe's decision to receive advance notification affect whether shipments pass within or across that tribe's reservation?
- I. How would licensees determine who the tribal contacts are?
- J. How would advance notifications be made to tribal officials?
- K. Would tribes be required to protect the advance notifications?
- L. Would tribal officials need to be fingerprinted and undergo a background investigation for unescorted access to shipments?
- IV. Section-by-Section Analysis
- V. Regulatory Flexibility Certification
- VI. Regulatory Analysis
- VII. Backfitting and Issue Finality
- VIII. Cumulative Effects of Regulation
- IX. Plain Writing
- X. National Environmental Policy Act
- XI. Paperwork Reduction Act Statement
- XII. Coordination With NRC Agreement States
- XIII. Compatibility of Agreement State Regulations
- XIV. Availability of Guidance
- XV. Public Meeting
- XVI. Availability of Documents

I. Obtaining Information and Submitting Comments

A. Obtaining Information

Please refer to Docket ID NRC–2022–0191 when contacting the NRC about the availability of information for this action. You may obtain publicly available information related to this action by any of the following methods:

- *Federal Rulemaking Website*: Go to <https://www.regulations.gov> and search for Docket ID NRC–2022–0191.
- *NRC's Agencywide Documents Access and Management System (ADAMS)*: You may obtain publicly available documents online in the ADAMS Public Documents collection at <https://www.nrc.gov/reading-rm/adams.html>. To begin the search, select "Begin Web-based ADAMS Search." For problems with ADAMS, please contact the NRC's Public Document Room (PDR) reference staff at 1–800–397–4209, at 301–415–4737, or by email to PDR.Resource@nrc.gov. For the convenience of the reader, instructions about obtaining materials referenced in this document are provided in the "Availability of Documents" section.
- *NRC's PDR*: The PDR, where you may examine and order copies of publicly available documents, is open by appointment. To make an appointment to visit the PDR, please send an email to PDR.Resource@nrc.gov or call 1–800–397–4209 or 301–415–4737, between 8 a.m. and 4 p.m. eastern time, Monday through Friday, except Federal holidays.

B. Submitting Comments

The NRC encourages electronic comment submission through the Federal rulemaking website (<https://www.regulations.gov>). Please include Docket ID NRC–2022–0191 in your comment submission.

The NRC cautions you not to include identifying or contact information that you do not want to be publicly disclosed in your comment submission. The NRC will post all comment submissions at <https://www.regulations.gov> as well as enter the comment submissions into ADAMS. The NRC does not routinely edit comment submissions to remove identifying or contact information.

If you are requesting or aggregating comments from other persons for submission to the NRC, then you should inform those persons not to include identifying or contact information that they do not want to be publicly disclosed in their comment submission. Your request should state that the NRC does not routinely edit comment submissions to remove such information before making the comment submissions available to the public or entering the comment into ADAMS.

II. Background

A. Petition for Rulemaking (PRM–37–2)

On December 4, 2020, Richard Arnold and Ron Johnson, on behalf of the Tribal Radioactive Materials Transportation Committee, submitted a petition for rulemaking (PRM), PRM–37–2, that requested that the NRC amend its regulations in part 37 of title 10 of the *Code of Federal Regulations* (10 CFR), "Physical Protection of Category 1 and Category 2 Quantities of Radioactive Material," to ensure consistency regarding advance Tribal notification of certain radioactive material shipments with similar NRC regulations for State notification. Currently 10 CFR part 37 only requires advance notification of certain radioactive material shipments to be sent to States, unlike the advance notification provisions of § 71.97, "Advance notification of shipment of irradiated reactor fuel and nuclear waste," and § 73.37, "Requirements for physical protection of irradiated reactor fuel in transit," which require advance notifications of specified shipments to be sent to States and participating federally recognized Tribes. The petitioner was concerned with "the divergence that exists in 10 CFR part 37 in contrast to the content that is provided in 10 CFR parts 71 and 73." The petitioner requested that consistent notification standards be applied to States and Tribal governments as well as

constituencies under their respective jurisdictions.

The NRC published a notice of docketing of the petition and request for comment in the **Federal Register** on April 9, 2021 (86 FR 18477). The NRC received 10 public comment submissions during the 75-day public comment period. Nine comment submissions supported the petition, while one comment submission and two individual comments within other comment submissions were outside the scope of the issue raised in the petition. On October 17, 2022, in SRM–SECY–22–0074, Petition for Rulemaking and Rulemaking Plan on Advance Tribal Notification of Certain Radioactive Material Shipments (PRM–37–2; NRC–2021–0051), the Commission determined that the issue raised in the petition would be addressed in rulemaking. On November 8, 2022, the NRC published a document in the **Federal Register** (87 FR 67397) stating that the NRC would consider the issue about advance notification of certain radioactive material shipments in its rulemaking process. Comments received on the petition were considered in development of this proposed rule.

B. Advance Notification Rule

The NRC published the final rule, "Advance Notification to Native American Tribes of Transportation of Certain Types of Nuclear Waste" (Advance Notification rule), in 2012.¹ The Advance Notification rule established the regulations in 10 CFR part 71, "Packaging and Transportation of Radioactive Material," and 10 CFR part 73, "Physical Protection of Plants and Materials," requiring NRC and Agreement State licensees to provide advance notification to federally recognized Tribal governments that choose to participate in the Tribal Advance Notification program before irradiated reactor fuel and certain nuclear waste shipments pass within or across the boundary of their Tribal reservations. The Advance Notification rule also provided relief from fingerprinting requirements to access safeguards information (SGI) for Tribal officials, designees, and law enforcement personnel.

The rulemaking resulted in advance notification requirements for shipments that pass within or across participating Tribal reservations that are similar to the 1982 requirements to notify States.² The rule's preamble also stated that the purpose of the rule was to recognize Tribal sovereignty and the Tribal

¹ See 77 FR 34194 (June 11, 2012).

² *Id.*

governments' interest in being informed of activities occurring on Tribal reservations.³ Currently, seven federally recognized Tribes participate in the voluntary Tribal Advance Notification program.

In March 2013, the NRC published the final rule, "Physical Protection of Byproduct Material," to establish security requirements for the use and transport of category 1 and category 2 quantities of radioactive material.⁴ The regulations in § 37.77, "Advance notification of shipment of category 1 quantities of radioactive material," require NRC and Agreement State licensees to provide advance notification to States of shipments of licensed material in a category 1 quantity that pass through or across the boundary of a State. As stated in this final rule, during the public comment period on the proposed rule (75 FR 33902; June 15, 2010), the NRC received a comment stating that the rule should provide for advance notification to Tribes for shipments that cross their reservations. The NRC's response in the final rule stated that the NRC may consider providing advance notification of these materials to Tribes in the future.⁵ The final 10 CFR part 37 rule, however, did not include provisions for Tribal notifications. Subsequently, the NRC published a final rule in the **Federal Register** in June 2013 that discussed Agreement State licensees' implementation of the Advance Notification rule.⁶ The document only addressed implementation of 10 CFR parts 71 and 73 advance Tribal notification requirements. The notice did not mention advance Tribal notifications under 10 CFR part 37.

III. Discussion

A. What action is the NRC taking?

The NRC is proposing to amend its regulations to require NRC and Agreement State licensees to provide to Tribal officials of participating federally recognized Tribes, or their designees, advance notice of shipments of category 1 quantities of radioactive material under § 37.77 before shipments pass within or across the Tribe's reservation boundary. As part of this amendment, the NRC is proposing to revise the language in part 37 from "through or across the boundary" by adopting the phrase "within or across the boundary" to be consistent with parts 71 and 73.

This action would only affect commercial shipments being made by NRC and Agreement State licensees. The NRC also is proposing to make changes to § 37.5, "Definitions," by adding definitions for "Indian Tribe" and "Tribal official," and § 37.29, "Relief from fingerprinting, identification, and criminal history records check and other elements of background investigations for designated categories of individuals permitted unescorted access to certain radioactive materials," to exempt Tribal officials or the Tribal official's designee and Tribal law enforcement personnel from fingerprinting requirements. Minor conforming changes will also be made to § 37.21, "Personnel access authorization requirements for category 1 or category 2 quantities of radioactive material," and § 37.43, "General security program requirements."

B. What persons would this action affect?

This proposed rule, if adopted, would apply to NRC and Agreement State licensees that ship category 1 quantities of radioactive materials. This proposed rule also would affect any federally recognized Tribe that chooses to participate in the Tribal Advance Notification program to receive the advance notifications of category 1 shipments that pass within or across its Tribal reservation.

C. Why do the requirements need to be revised?

The § 37.77 provisions require advance notification to State governments but not Tribal governments for shipments of category 1 quantities of radioactive material. In comparison, 10 CFR parts 71 and 73 provisions require advance notification to both State and participating federally recognized Tribal governments for shipments of certain types of radioactive material. Therefore, the current requirements in 10 CFR part 37 are inconsistent with requirements in 10 CFR parts 71 and 73. The NRC recognizes Tribal sovereignty and Tribal governments' interest in being informed of category 1 radioactive material shipments that would pass within or across reservations of participating federally recognized Tribes. This action also would support the NRC's Tribal Policy Statement, which established the NRC's principles to promote effective Government-to-Government interactions with federally recognized Tribes and to encourage and facilitate Tribal involvement in the areas over which the Commission has jurisdiction. Revising 10 CFR part 37 would provide consistency with 10 CFR parts 71 and

73 regarding advance Tribal notification of certain radioactive material shipments, implement the principles in the Tribal Policy Statement, and further the NRC's commitment to its Principles of Good Regulation. Additionally, the importance of communication among the States, Tribes, and the public supports the NRC's amendments in this proposed rule.

D. Would all tribes receive advance notifications?

No. Only federally recognized Tribes that participate in the voluntary Tribal Advance Notification program would receive notification of category 1 quantities of radioactive material under 10 CFR part 37 and receive notification of irradiated reactor fuel and other nuclear waste shipments that pass within or across their reservation under 10 CFR parts 71 and 73. The advance notification program recognizes Tribal sovereignty and Tribal governments' interest in being cognizant of activities taking place on their reservations.

E. How and when would tribes be given the option to receive advance notifications?

If this proposed rule is finalized, the NRC staff would inform each federally recognized Tribe of the rule amendment. As part of the information, the non-participating federally recognized Tribes would be asked if they would like to participate in the Tribal Advance Notification program to receive advance notifications of category 1 quantities of radioactive material shipments, irradiated reactor fuel, and other nuclear waste shipments that pass within or across the boundary of the Tribal reservation. The Tribes can then notify the NRC whether they would like to participate in the Tribal Advance Notification program and certify that any information received regarding shipments of category 1 quantities of radioactive material would be protected against unauthorized disclosure according to § 37.43(d). The Tribes also would be able to change their decision to participate in the Tribal Advance Notification program by informing the NRC at any time. In addition, the NRC would contact all federally recognized Tribes to give them an opportunity to opt into the Tribal Advance Notification program: (1) every 5 years; (2) after a Tribe achieves Federal recognition; and (3) when a transportation route is approved that is within a reservation or crosses a reservation boundary of a federally recognized Tribe. Before participating in the advance notification program, a Tribe would submit the following information: (1) a certification

³ *Id.*

⁴ See 78 FR 16922 (March 19, 2013).

⁵ See *id.* at 16991.

⁶ See "Advance Notification to Native American Tribes of Transportation of Certain Shipments of Nuclear Waste" (78 FR 35746; June 14, 2013).

that the Tribal official or their designee(s) has (or have) taken training on the handling of Safeguards Information; (2) a certification that the Tribe has the necessary protection measures in place and will protect the SGI; (3) the contact information for the Tribal official or the Tribal official's designee(s) (when a Tribal official is designating another person to receive the advance notifications); (4) an affirmation of the boundaries of the Tribe's reservation or the necessary corrections to a map provided by the NRC; and (5) the name and contact information for the Indian Tribe's emergency response contact(s).

F. What notifications would tribes receive?

By choosing to participate in the Tribal Advance Notification program, federally recognized Tribes would receive notification under 10 CFR part 37 for shipments of category 1 quantities for radioactive material, and 10 CFR parts 71 and 73 for shipments of irradiated reactor fuel and nuclear waste that pass within or across the boundaries of their Tribal reservation.

G. Do tribes who currently receive notifications under parts 71 and 73 need to take additional action?

No. Tribes that have already elected to participate in the Tribal Advance Notification program would automatically receive notification of shipments of category 1 quantities of radioactive material that may pass within or across their reservation. If this rule goes final, the NRC staff intends to contact non-participating federally recognized Tribes after the effective date of the rule to see if they would like to join the advance Tribal notification program.

H. Does a tribe's decision to receive advance notification affect whether shipments pass within or across that tribe's reservation?

No. This proposed rule would only give the Tribes a voluntary opportunity to receive advance notification of shipments that pass within or across their reservation. A Tribe's decision to receive or not receive advance notifications does not affect shipment routes.

I. How would licensees determine who the tribal contacts are?

The NRC maintains a list of Tribal contacts as it does for State governmental contacts. The NRC works with the Tribes to maintain the list. The Tribal official designates who is intended to represent the Tribe. The

NRC annually publishes a list of Tribal contacts in the **Federal Register** and posts it on a website maintained by the NRC's Office of Nuclear Material Safety and Safeguards at <https://scp.nrc.gov>.

J. How would advance notifications be made to tribal officials?

The methods permitted for communication of advance notifications are detailed in § 37.77(a), "Procedures for submitting advance notification."

K. Would tribes be required to protect the advance notifications?

Tribes would be required to protect the schedule and itinerary information contained in the advance notification against unauthorized disclosure as specified in § 37.43(d).

L. Would tribal officials need to be fingerprinted and undergo a background investigation for unescorted access to shipments?

Under the proposed rule, if the Tribe decides to participate in the Tribal Advance Notification program, the Tribal official, Tribal official designee, or Tribal law enforcement personnel may have unescorted access to certain radioactive materials without undergoing fingerprinting or a criminal history check. The Tribal official, Tribal official designee, or Tribal law enforcement personnel who needs to know shipment information to perform their job function may also have access to shipment schedule and itinerary information regarding advance notification of shipments passing within or across their Tribal reservation.

Section 149 of the Atomic Energy Act of 1954, as amended (AEA), requires fingerprinting and submission of fingerprints to the Attorney General of the United States for identification and criminal history records check for any individual permitted unescorted access to radioactive material or other property subject to regulation by the Commission that the Commission determines to be of such significance to the public health and safety or the common defense and security as to warrant fingerprinting and background checks, unless the Commission, by rule, has relieved that individual from the fingerprinting, identification, and criminal history records check requirements. The Commission may relieve individuals from these regulatory requirements "if the Commission finds that such action is consistent with its obligations to promote the common defense and security and protect the health and safety of the public." As allowed by Section 149 of the AEA, the NRC enacted § 37.29 to relieve specific

categories of individuals from fingerprinting and criminal history record checks prior to receiving unescorted access to certain radioactive materials.

The United States has a unique legal relationship with Indian Tribal governments as set forth in the Constitution of the United States, treaties, statutes, Executive Orders, and court decisions. Indian Tribes exercise inherent sovereign powers over their members and territory. The United States recognizes the right of Indian Tribes to self-government and supports Tribal sovereignty and self-determination. As a result, the NRC has determined that exempting Tribal officials, Tribal official designees, or Tribal law enforcement personnel is analogous to exempting the State governor, State governor designees, or State law enforcement personnel from the fingerprinting and background check requirements. Furthermore, some Tribes have emergency response responsibilities similar to States. Revising the regulation would permit the Commission and licensees to more efficiently approve unescorted access to certain radioactive materials relating to advance notification of shipments to Tribes. This proposed rule would enable the Tribes to be more effective in their day-to-day efforts to ensure the protection of certain radioactive materials and respond to emergencies within their territories. Therefore, the Commission has determined that these proposed revisions would help the Commission fulfill its obligations to promote the common defense and security and to protect the health and safety of the public.

This proposed rule would add Tribal official, their designee, and Tribal law enforcement personnel to the list of categories of individuals that are granted relief from the fingerprinting, identification and criminal history records checks, and other elements of background checks. Those individuals granted access to advance notifications are required to abide by the requirements in § 37.43(d) for proper management and protection of information.

IV. Section-by-Section Analysis

The following paragraphs describe the specific changes proposed by this rulemaking.

Section 37.5 Definitions

This proposed rule adds definitions for "Indian Tribe" and "Tribal official."

Section 37.21 Personnel Access Authorization Requirements for Category 1 or Category 2 Quantities of Radioactive Material

This proposed rule would revise § 37.21(c)(2) to make a conforming change to update the reference from § 37.29(a)(13) to read § 37.29(a)(14).

Section 37.29 Relief From Fingerprinting, Identification, and Criminal History Records Checks and Other Elements of Background Investigations for Designated Categories of Individuals Permitted Unescorted Access to Certain Radioactive Materials

This proposed rule would revise § 37.29 by removing the word “and” after paragraph (a)(12) and adding it after paragraph (a)(13), and adding a new paragraph (a)(14) to exempt Tribal officials from the fingerprinting requirement.

Section 37.43 General Security Program Requirements

This proposed rule would revise § 37.43(d)(4)(i) to make a conforming change to update the reference from “§ 37.29(a)(1) through (13)” to read “§ 37.29(a)(1) through (14)”.

Section 37.77 Advance Notification of Shipment of Category 1 Quantities of Radioactive Material

This proposed rule would revise the introductory paragraph in § 37.77 to specify that NRC and Agreement State licensees shall provide advance notification to the Tribal official of participating federally recognized Tribes, or the official’s designee, of the shipment of licensed material in category 1 quantities that passes within or across the Tribe’s reservation. In addition, this section would be revised to make conforming changes.

V. Regulatory Flexibility Certification

As required by the Regulatory Flexibility Act of 1980, 5 U.S.C. 605(b), the Commission certifies that this rule, if adopted, will not have a significant economic impact on a substantial number of small entities. This proposed rule would affect a number of “small entities” as defined by the Regulatory Flexibility Act or the size standards established by the NRC (10 CFR 2.810). However, as indicated in the draft regulatory analysis available under the “Availability of Documents” section, the proposed amendments, if promulgated, would not have a significant economic impact on the affected small entities.

Any small entity subject to this regulation that determines, because of its size, it is likely to bear a

disproportionate adverse economic impact should notify the Commission of this opinion in a comment that indicates—

(a) The licensee’s size and how the proposed regulation would impose a significant economic burden on the licensee as compared to the economic burden on a larger licensee;

(b) How the proposed regulations could be modified to take into account the licensee’s differing needs or capabilities;

(c) The benefits that would accrue or the detriments that would be avoided if the proposed regulations were modified as suggested by the licensee;

(d) How the proposed regulation, as modified, would more closely equalize the impact of NRC regulations or create more equal access to the benefits of Federal programs as opposed to providing special advantages to any individual or group; and

(e) How the proposed regulation, as modified, would still adequately protect public health and safety.

Comments should be submitted as indicated under the **ADDRESSES** caption.

VI. Regulatory Analysis

The NRC has prepared a draft regulatory analysis on this proposed regulation. The analysis examines the costs and benefits of the alternatives considered by the NRC. The conclusion from the analysis is that this proposed rule would result in net costs to the industry, the NRC, Agreement States, and Tribal governments of \$2.9 million using a 7-percent discount rate and \$3.4 million using a 3-percent discount rate. Although the proposed rule would not be quantitatively cost effective, the costs for Tribes would be marginal and the costs for the NRC, industry, and Agreement States would be small and incremental because of the existing regulatory regime that created the Advance Tribal Notification program. The proposed rule would provide qualitative benefits by increasing regulatory efficiency and effectiveness for both the NRC and industry, would provide Tribal governments with greater regulatory predictability, would enhance the transparency of the Tribal Advance Notification program, and would resolve an inconsistency among the NRC’s advance notification regulations in 10 CFR part 37 and 10 CFR parts 71 and 73. The proposed rule is also consistent with the NRC’s Principles of Good Regulation and specifically Principle 2 in the NRC’s Tribal Policy Statement, which states that the NRC recognizes the right of each Indian Tribe to self-governance and Tribal sovereignty and the right to

self-governance. The NRC requests public comment on the draft regulatory analysis. The regulatory analysis is available as indicated in the “Availability of Documents” section of this document. Comments on the draft analysis may be submitted to the NRC as indicated under the **ADDRESSES** caption of this document.

VII. Backfitting and Issue Finality

The NRC has determined that the backfit rule, which is found in the regulations at 10 CFR 50.109, 70.76, 72.62, 76.76, and in 10 CFR part 52, does not apply to this rulemaking because this amendment would not involve any provisions that would impose backfits as defined in 10 CFR chapter I. Therefore, a backfit analysis is not required.

VIII. Cumulative Effects of Regulation

The staff’s preliminary assessment of the cumulative effects of regulation concludes that no known activities or affected entities would be impacted significantly by implementing the proposed changes. To ensure adequate identification of potential effects not currently foreseen, the staff plans to solicit Agreement State input on this issue during the proposed and final rule phases of this rulemaking.

IX. Plain Writing

The Plain Writing Act of 2010 (Pub. L. 111–274) requires Federal agencies to write documents in a clear, concise, and well-organized manner. The NRC has written this document to be consistent with the Plain Writing Act as well as the Presidential Memorandum, “Plain Language in Government Writing,” published June 10, 1998. The NRC requests comment on this document with respect to the clarity and effectiveness of the language used.

X. National Environmental Policy Act

The NRC has determined that this proposed rule is the type of action described in the categorical exclusion at 10 CFR 51.22(c)(3)(v). Therefore, neither an environmental impact statement nor environmental assessment has been prepared for this proposed rule.

XI. Paperwork Reduction Act

This proposed rule contains amended collections of information contained in 10 CFR part 37 and “Tribal Participation in the Advance Notification Program” subject to the Paperwork Reduction Act of 1995 (44 U.S.C. 3501 *et seq.*). This proposed rule has been submitted to the Office of Management and Budget (OMB) for review and approval of the information collections.

Type of submission, new or revision: Revision.

The title of the information collection: Advance Tribal Notification of Category 1 Quantities of Radioactive Material Shipments.

The form number if applicable: Not Applicable.

How often the collection is required or requested: On occasion for licensees making notifications of shipments of category 1 quantities of radioactive material that will pass within or across the reservations of federally recognized Tribes participating in the NRC's Tribal Advance Notification program. For participating Tribes, information would be requested: (1) every 5 years; (2) after an Indian Tribe achieves Federal recognition; (3) when a transportation route is approved that is within a reservation or crosses a reservation boundary; (4) when there is a change in Tribal leadership or the Tribal official's designation; and (5) once, after the final rule is approved by the Commission.

Who will be required or asked to respond: NRC licensees and Agreement State licensees who ship category 1 quantities of radioactive material and federally recognized Tribal governments choosing to opt-in to the Tribal Advance Notification program for certain radioactive material shipments.

An estimate of the number of annual responses: 20 (14 for part 37 licensees and 6 for participating Tribes).

The estimated number of annual respondents: 10 (6 part 37 licensees and 4 participating Tribes.)

An estimate of the total number of hours needed annually to comply with the information collection requirement or request: 25 hours for part 37 licensees (25 third-party disclosure hours). 17 hours for participating Tribes (11 hours reporting + 6 recordkeeping hours).

Abstract: The NRC recognizes Tribal sovereignty and Tribal governments' interest in being informed of category 1 radioactive material shipments that would pass within or across reservations of participating federally recognized Tribes. The information collections related to the proposed rule would include licensee third-party disclosures for advance written notification to the Tribes of category 1 shipments, notification of revisions of shipments to the Tribes, cancellation notifications to Tribes, and recordkeeping including maintaining copies of the advance notifications, revisions, and cancellation notices.

This proposed rule would enable federally recognized Tribes to opt into the NRC Tribal Advance Notification program under 10 CFR part 37 to receive notifications of shipments of category 1

quantities of radioactive material that pass within or across their reservation under 10 CFR part 37, along with notifications of certain shipments of nuclear waste and shipments of irradiated reactor fuel under 10 CFR parts 71 and 73. Federally recognized Indian Tribes would affirmatively opt-in to receive the notifications by providing certain information to the NRC. The NRC would use the collected information to implement the advance notification program, which includes the following purposes: first, information would be collected and made available to licensees to enable licensees to comply with NRC and Agreement State regulations. Second, information would be collected to facilitate correspondence to the Tribal official, Tribal official's designated representative, or the Tribe's emergency response contact on matters related to transportation of shipments of certain types of radioactive material or the implementation of the advance notification program.

The NRC is seeking public comment on the potential impact of the information collection(s) contained in this proposed rule and on the following issues:

1. Is the proposed information collection necessary for the proper performance of the functions of the NRC, including whether the information will have practical utility? Please explain your answer.

2. Is the estimate of the burden of the proposed information collection accurate? Please explain your answer.

3. Is there a way to enhance the quality, utility, and clarity of the information to be collected?

4. How can the burden of the proposed information collection on respondents be minimized, including the use of automated collection techniques or other forms of information technology?

There are two OMB supporting statements associated with this proposed rule; one related to 10 CFR part 37 and one relating to Tribal participation in the Advance Notification program. A copy of the OMB clearance packages and proposed rule are available in ADAMS under Accession No. ML23285A083 and Accession No. ML23285A084 and may be obtained free of charge by contacting the NRC's Public Document Room reference staff at 1-800-397-4209, at 301-415-4737, or by email to PDR.Resource@nrc.gov. You may obtain information and comment submissions related to the OMB clearance package by searching on <https://>

www.regulations.gov under Docket ID NRC-2022-0191.

You may submit comments on any aspect of these proposed information collection(s), including suggestions for reducing the burden and on the above issues, by the following methods:

- *Federal Rulemaking Website:* Go to <https://www.regulations.gov> and search for Docket ID NRC-2022-0191.

- *Mail comments to:* FOIA, Library, and Information Collections Branch, Office of the Chief Information Officer, Mail Stop: T-6 A10M, U.S. Nuclear Regulatory Commission, Washington, DC 20555-0001 or to the OMB reviewer at OMB Office of Information and Regulatory Affairs (3150-0214 and 3150-0250), Attention: Desk Officer for the Nuclear Regulatory Commission, 725 17th Street NW, Washington, DC 20503.

Submit comments by April 8, 2024. Comments received after this date will be considered if it is practical to do so, but the NRC staff is able to ensure consideration only for comments received on or before this date.

Public Protection Notification

The NRC may not conduct or sponsor, and a person is not required to respond to, a collection of information unless the document requesting or requiring the collection displays a currently valid OMB control number.

XII. Coordination With NRC Agreement States

A Government-to-Government meeting was held on October 4, 2023, to share early drafts of and discuss this proposed rule with Agreement States. Comments from Agreement States will be taken into consideration during the development of the final rule.

XIII. Compatibility of Agreement State Regulations

Under the "Agreement State Program Policy Statement," approved by the Commission on October 2, 2017, and published in the **Federal Register** (82 FR 48535; October 18, 2017), NRC program elements (including regulations) required for adequacy and having a particular health and safety component are those that are designated as categories A, B, C, D, NRC, and H&S; and those required for compatibility include those regulations and other legally binding requirements designated as compatibility categories A, B, C, and D. Compatibility category A are those program elements that include basic radiation protection standards and scientific terms and definitions that are necessary to understand radiation protection concepts. An Agreement

State should adopt category A program elements in an essentially identical manner in order to provide uniformity in the regulation of agreement material on a nationwide basis. Compatibility category B are those program elements that apply to activities that have direct and significant effects in multiple jurisdictions. Compatibility category B pertains to a limited number of program elements that cross jurisdictional boundaries and should be addressed to ensure uniformity of regulation on a nationwide basis. The Agreement State program element should be essentially identical to that of NRC. Compatibility category C are those program elements that do not meet the criteria of category A or B, but the essential objectives of which an Agreement State should adopt to avoid conflict, duplication, gaps, or other conditions that would jeopardize an orderly pattern in the regulation of agreement material on a national basis. An Agreement State should adopt the essential objectives of the category C program elements. Compatibility category D are those program elements that do not meet any of the criteria of category A, B, or C, above, and, thus, do not need to be adopted by Agreement States for purposes of compatibility. Compatibility category NRC are those program elements that address areas of regulation that cannot be relinquished

to the Agreement States under the Atomic Energy Act of 1954, as amended, or provisions of 10 CFR. These program elements should not be adopted by the Agreement States. Category H&S program elements are not required for purposes of compatibility; however, they do have particular health and safety significance. The Agreement State should adopt the essential objectives of such program elements to maintain an adequate program.

This proposed rule is a matter of compatibility between the NRC and the Agreement States, thereby providing consistency among Agreement State and NRC requirements. The Agreement States adopted portions of the Advance Tribal Notification Rule that required Agreement State licensees to provide advance notification to participating federally recognized Tribes for shipments of irradiated reactor fuel and specific types of nuclear waste. The regulations defining “Indian Tribe,” “Tribal Official” and 10 CFR 71.97, “Advance notification of the shipment of irradiated reactor fuel and nuclear waste” were designated as compatibility category “B” in the rulemaking. (See 77 FR 34194, 34203, June 11, 2012.) In comparison, the advance notification provisions in 10 CFR part 73 are compatibility category “NRC” and only apply to NRC licensees. The Agreement

States cannot adopt these regulatory requirements. The NRC anticipates that the associated requirements in this proposed rulemaking will remain as compatibility category B, requiring the Agreement States to adopt essentially identical provisions. Agreement States would need to adopt compatible program elements for the revised subparts that would be affected by this proposed rulemaking.

Advance notification for category 1 material shipments to the participating federally recognized Tribes would be provided by NRC and Agreement State licensees, similar to the advance notification already being provided to States for these shipments. Although they would need to adopt compatible program elements, Agreement States would not be providing advance notification to the participating Tribes. The NRC would be applying the principles of the Tribal Policy Statement and the NRC’s Principles of Good Regulations to the NRC’s regulatory activities, which include having consistency between the advance notification provisions between States and Tribes for 10 CFR part 37 category 1 quantities of radioactive materials. The compatibility categories are designated in the following table:

COMPATIBILITY TABLE

Section	Change	Subject	Compatibility	
			Existing	New
37.5	New	Definitions “Indian Tribe”	B
37.5	New	Definitions “Tribal Leader”	B
37.21(c)	Amend	Personnel access authorization requirements for category 1 or category 2 quantities of radioactive material.	B	B
37.29(a)	Amend	Relief from fingerprinting, identification, and criminal history records checks and other elements of background investigations for designated categories of individuals permitted unescorted access to certain radioactive materials.	B	B
37.43(d)	Amend	General security program requirements	C	C
37.77(a)–(d)	Amend	Advance notification of shipment of category 1 quantities of radioactive material	B	B
37.77(f)	Amend	Advance notification of shipment of category 1 quantities of radioactive material	C	C

XIV. Availability of Guidance

The NRC expects to update NUREG–2155, “Implementation Guidance for 10 CFR part 37, ‘Physical Protection of Category 1 and Category 2 Quantities of Radioactive Material,’” to conform with this rulemaking effort. To support the development schedule for this proposed rule, the updates will be made in a future revision of the guidance rather than concurrently with this rulemaking. Interim guidance, in the form of frequently asked questions (FAQs), will be added to the NRC’s public website.

The draft FAQs are available in ADAMS under Accession No. ML23277A107 and in the docket for the proposed rule (NRC–2022–0191). You may submit comments on the draft FAQs by the methods outlined in the ADDRESSES section of this document.

XV. Public Meeting

The NRC will conduct a public meeting on the proposed rule during the public comment period for the purpose of describing the proposed rule to the public. The NRC will publish a notice of the location, time, and agenda of the

meeting on *Regulations.gov* and on the NRC’s public meeting website at least 10 calendar days before the meeting. Stakeholders should monitor the NRC’s public meeting website for information about the public meeting at: <https://www.nrc.gov/public-involve/public-meetings/index.cfm>.

XVI. Availability of Documents

The documents identified in the following table are available to interested persons through one or more of the following methods, as indicated.

Document	ADAMS accession No./web link/Federal Register citation
SRM–SECY–22–0074, Petition for Rulemaking and Rulemaking Plan on Advance Tribal Notification of Certain Radioactive Material Shipments (PRM–37–2; NRC–2021–0051), October 17, 2022.	ML22290A240 (Package).
SECY–22–0074: Petition for Rulemaking and Rulemaking Plan on Advance Tribal Notification of Certain Radioactive Material Shipments (PRM–37–2; NRC–2021–0051), August 10, 2022.	ML22056A316 (Package).
Regulatory Analysis for the Proposed Rule: Advance Notification of Category 1 Quantities of Radioactive Material Shipments, February 2024.	ML23277A108.
NUREG–2155, “Implementation Guidance for 10 CFR Part 37, ‘Physical Protection of Category 1 and Category 2 Quantities of Radioactive Material,’” March 2022.	ML22083A141.
Advance Tribal Notification of Category 1 Quantities of Radioactive Material Shipments Rule—Frequently Asked Questions, February 2024.	ML23277A107.
PRM–37–2, Consideration in the Rulemaking Process, Advance Tribal Notification of Certain Radioactive Material Shipments, November 8, 2022.	87 FR 67397.
PRM–37–2, Notice of Docketing and Request for Comment, Advance Tribal Notification of Certain Radioactive Material Shipments, April 9, 2021.	86 FR 18477.
PRM–37–2, R. Arnold & R. Johnson on Behalf of the Tribal Radioactive Materials Transportation on Advance Tribal Notification of Certain Radioactive Material Shipments, December 4, 2020.	ML21042B011.
Advance Notification to Native American Tribes of Transportation of Certain Shipments of Nuclear Waste, June 14, 2013.	78 FR 35746.
Executive Order 13175, “Consultation and Coordination with Indian Tribal Governments,” November 6, 2000.	65 FR 67249.
Tribal Policy Statement, January 9, 2017	82 FR 2402.
Final Rule—Physical Protection of Byproduct Material, March 19, 2013	78 FR 16922.
Proposed Rule—Physical Protection of Byproduct Material, June 15, 2010	75 FR 33902.
Final Rule—Advance Notification to Native American Tribes of Transportation of Certain Types of Nuclear Waste, June 11, 2012.	77 FR 34194.
Principles of Good Regulation	https://www.nrc.gov/about-nrc/values.html#principles .
The Plain Writing Act of 2010 (Pub. L. 111–274)	https://www.govinfo.gov/app/details/PLAW-111publ274 .
“Plain Language in Government Writing,” June 10, 1998	63 FR 31885.
OMB Supporting Statement—10 CFR Part 37—Physical Protection of Category 1 and Category 2 Quantities of Radioactive Material (OMB Clearance No. 3150–0214).	ML23285A083.
OMB Supporting Statement for Tribal Participation in the Advance Notification Program (OMB Clearance No. 3150–0250).	ML23285A084.

The NRC may post materials related to this document, including public comments, on the Federal rulemaking website at <https://www.regulations.gov> under Docket ID NRC–2022–0191. In addition, the Federal rulemaking website allows members of the public to receive alerts when changes or additions occur in a docket folder. To subscribe: (1) navigate to the docket folder (NRC–2022–0191); (2) click the “Subscribe” link; and (3) enter an email address and click on the “Subscribe” link.

List of Subjects in 10 CFR Part 37

Byproduct material, Criminal penalties, Exports, Hazardous materials transportation, Imports, Licensed material, Nuclear materials, Penalties, Radioactive materials, Reporting and recordkeeping requirements, Security measures.

For the reasons set out in the preamble and under the authority of the Atomic Energy Act of 1954, as amended; the Energy Reorganization Act of 1974, as amended; and 5 U.S.C. 552 and 553, the NRC is proposing to amend 10 CFR part 37.

PART 37—PHYSICAL PROTECTION OF CATEGORY 1 AND CATEGORY 2 QUANTITIES OF RADIOACTIVE MATERIAL

■ 1. The authority citation for part 37 continues to read as follows:

Authority: Atomic Energy Act of 1954, secs. 11, 53, 81, 103, 104, 147, 148, 149, 161, 182, 183, 223, 234, 274 (42 U.S.C. 2014, 2073, 2111, 2133, 2134, 2167, 2168, 2169, 2201, 2232, 2233, 2273, 2282, 2021); Energy Reorganization Act of 1974, secs. 201, 202 (42 U.S.C. 5841, 5842); 44 U.S.C. 3504 note.

■ 2. In § 37.5, add, in alphabetical order, definitions for “Indian Tribe” and “Tribal official” to read as follows:

§ 37.5 Definitions.

* * * * *

Indian Tribe means an Indian or Alaska Native Tribe, band, nation, pueblo, village, or community that the Secretary of the Interior acknowledges to exist as an Indian Tribe pursuant to the Federally Recognized Indian Tribe List Act of 1994, 25 U.S.C. 5130.

* * * * *

Tribal official means the highest-ranking individual that represents

Tribal leadership, such as the Chief, President, or Tribal Council leadership.
* * * * *

§ 37.21 [Amended]

■ 3. In § 37.21(c)(2), remove the reference “(13)” and add, in its place, the reference “(14)”.

■ 4. In § 37.29, remove the word “and” after paragraph (a)(12), revise paragraph (a)(13), and add (a)(14) to read as follows:

§ 37.29 Relief from fingerprinting, identification, and criminal history records checks and other elements of background investigations for designated categories of individuals permitted unescorted access to certain radioactive materials

(a) * * *

(13) Any individual employed by a service provider licensee for whom the service provider licensee has conducted the background investigation for the individual and approved the individual for unescorted access to category 1 or category 2 quantities of radioactive material. Written verification from the service provider must be provided to the licensee. The licensee shall retain the documentation for a period of 3 years from the date the individual no longer requires unescorted access to category 1

or category 2 quantities of radioactive material; and

(14) The Tribal official or Tribal official's designee, and Tribal law enforcement personnel.

* * * * *

§ 37.43 [Amended]

■ 5. In § 37.43(d)(4)(i), remove the reference “(13)” and add, in its place, the reference “(14)”.

■ 6. In § 37.77, revise the introductory paragraph and paragraphs (a)(1) and (3); in paragraph (b)(5), remove the word “State” and add in its place the phrase, “State or Tribal reservation boundary”; and revise paragraphs (c), (d), and (f) to read as follows:

§ 37.77 Advance notification of shipment of category 1 quantities of radioactive material.

As specified in paragraphs (a) and (b) of this section, each licensee shall provide advance notification to the NRC, the governor of a State, or the governor's designee, and the Tribal official or the Tribal official's designee of participating Tribes referenced in paragraph (a)(1) of this section, of the shipment of licensed material in a category 1 quantity, within or across the boundary of the State, or within or across the boundary of the Tribal reservation, before the transport, or delivery to a carrier for transport of the licensed material outside the confines of the licensee's facility or other place of use or storage.

(a) * * *

(1) The notification must be made to the NRC, to the office of each appropriate governor or governor's designee, and to the office of each participating Tribal official or Tribal official's designee. The contact information, including telephone and mailing addresses, of governors and governors' designees, and participating Tribes' officials and Tribal official's designees, is available on the NRC's website at <https://scp.nrc.gov/special/designee.pdf>. A list of the contact information also is available upon request from the Director, Division of Materials Safety, Security, State, and Tribal Programs, Office of Nuclear Material Safety and Safeguards, U.S. Nuclear Regulatory Commission, Washington, DC 20555-0001. Notifications to the NRC must be to the NRC's Director, Office of Nuclear Security and Incident Response, U.S. Nuclear Regulatory Commission, Washington, DC 20555-0001. The notification to the NRC may be made by email to RAMQC_SHIPMENTS@nrc.gov or by fax to 301-816-5151.

* * * * *

(3) A notification delivered by any means other than mail must reach NRC at least 4 days before the transport of the shipment commences and must reach the office of the governor or the governor's designee or the Tribal official or Tribal official's designee at least 4 days before transport of a shipment within or across the State or Tribal reservation boundary.

* * * * *

(c) *Revision notice.* (1) The licensee shall provide any information not previously available at the time of the initial notification, as soon as the information becomes available but not later than commencement of the shipment, to the governor of the State or the governor's designee, the Tribal official or Tribal official's designee, and to the NRC's Director, Office of Nuclear Security and Incident Response, U.S. Nuclear Regulatory Commission, Washington, DC 20555-0001.

(2) A licensee shall promptly notify the governor of the State or the governor's designee and the Tribal official or Tribal official's designee of any changes to the information provided in accordance with paragraphs (b) and (c)(1) of this section. The licensee shall also immediately notify the NRC's Director, Office of Nuclear Security and Incident Response, U.S. Nuclear Regulatory Commission, Washington, DC 20555-0001 of any such changes.

(d) *Cancellation notice.* Each licensee who cancels a shipment for which advance notification has been sent shall send a cancellation notice to the governor of each State or to the governor's designee and Tribal official or Tribal official's designee previously notified and to the NRC's Director, Office of Nuclear Security and Incident Response, U.S. Nuclear Regulatory Commission, Washington, DC 20555-0001. The licensee shall send the cancellation notice before the shipment would have commenced or as soon thereafter as possible. The licensee shall state in the notice that it is a cancellation and identify the advance notification that is being cancelled.

* * * * *

(f) *Protection of information.* State officials, State employees, Tribal officials, Tribal employees, and other individuals, whether or not licensees of the Commission or an Agreement State, who receive schedule information of the kind specified in § 37.77(b) shall protect that information against unauthorized disclosure as specified in § 37.43(d) of this part.

Dated: February 20, 2024.

For the Nuclear Regulatory Commission.

Raymond Furstenau,

Executive Director for Operations.

[FR Doc. 2024-04771 Filed 3-7-24; 8:45 am]

BILLING CODE 7590-01-P

DEPARTMENT OF TRANSPORTATION

Federal Aviation Administration

14 CFR Part 21

[Docket No. FAA-2023-2316]

Restricted Category Special Purpose Operation of Humanitarian, Emergency, and Disaster Aerial Delivery

AGENCY: Federal Aviation Administration (FAA), DOT.

ACTION: Notice of availability; request for comments.

SUMMARY: This document is requesting comments on the addition of a restricted category special purpose operation of Humanitarian, Emergency, and Disaster Aerial Delivery, pursuant to Title 14 of the Code of Federal Regulations (14 CFR) 21.25(b)(7).

DATES: Send comments on or before April 8, 2024.

ADDRESSES: Send comments identified by docket number FAA-2023-2316 using any of the following methods:

- *Federal eRulemaking Portal:* Go to <http://www.regulations.gov> and follow the online instructions for sending your comments electronically.

- *Mail:* Send comments to Docket Operations, M-30; U.S. Department of Transportation (DOT), 1200 New Jersey Avenue SE, Room W12-140, West Building Ground Floor, Washington, DC 20590-0001.

- *Hand Delivery or Courier:* Take comments to Docket Operations in Room W12-140 of the West Building Ground Floor at 1200 New Jersey Avenue SE, Washington, DC, between 9 a.m. and 5 p.m., Monday through Friday, except Federal holidays.

- *Fax:* Fax comments to Docket Operations at 202-493-2251.

- *Docket:* Background documents or comments received may be read at <https://www.regulations.gov/> at any time. Follow the online instructions for accessing the docket or go to Docket Operations in Room W12-140 of the West Building Ground Floor at 1200 New Jersey Avenue SE, Washington, DC, between 9 a.m. and 5 p.m., Monday through Friday, except Federal holidays.

FOR FURTHER INFORMATION CONTACT: Graham Long, Design and Maintenance Systems Section (AIR-631),

Organization and System Policy Branch, Policy and Standards Division, Aircraft Certification Service, by email at graham.long@faa.gov or by phone at (202) 267-1624.

SUPPLEMENTARY INFORMATION:

A. Comments Invited

The FAA invites interested persons to participate by submitting written comments, data, or views. To ensure the docket does not contain duplicate comments, commenters should submit only one time if comments are filed electronically, or commenters should send only one copy of written comments if comments are filed in writing.

The FAA will file in the docket all comments it receives, as well as a report summarizing each substantive public contact with FAA personnel concerning this notice. Before acting on this proposal, the FAA will consider all comments it receives on or before the closing date for comments. The FAA will consider comments filed after the comment period has closed if it is possible to do so without incurring expense or delay. The FAA may change this proposal in light of the comments it receives.

B. Privacy

Except for Confidential Business Information (CBI) as described in the following paragraph, and other information as described in title 14, Code of Federal regulations (14 CFR) 11.35, the FAA will post all comments received without change to <http://www.regulations.gov>, including any personal information you provide.

C. Confidential Business Information

Confidential Business Information (CBI) is commercial or financial information that is both customarily and actually treated as private by its owner. Under the Freedom of Information Act (FOIA) (5 U.S.C. 552), CBI is exempt from public disclosure. If your comments responsive to this document contain commercial or financial information that is customarily treated as private, that you actually treat as private, and that is relevant or responsive to this document, it is important that you clearly designate the submitted comments as CBI. Please mark each page of your submission containing CBI as "PROPIN." The FAA will treat such marked submissions as confidential under the FOIA, and the indicated comments will not be placed in the public docket of this document. Send submissions containing CBI to the information contact person listed above. Comments the FAA receives, which are

not specifically designated as CBI, will be placed in the public docket for this document.

Background

The FAA is considering a new restricted category special purpose operation of Humanitarian, Emergency, and Disaster Aerial Delivery, pursuant to 14 CFR 21.25(b)(7). Recent natural disasters in the United States have prompted the FAA to consider making available additional aviation resources to deliver material for humanitarian, emergency, and disaster relief activities. The proposed special purpose operation involves aerial delivery of materials and supplies to the affected area.

Approval of this new special purpose operation would expand the usability of restricted category aircraft and support the public welfare. It is in the public interest to support remote communities and areas that are otherwise inaccessible to provide humanitarian, emergency, and disaster relief. These activities can provide support for the World Food Program, International Red Cross, Federal Emergency Management Agency, and other governmental or non-governmental organizations throughout the United States and the world.

The FAA is considering limiting this approval to periods when a government agency has made a declaration of a state of emergency, or a similar declaration. Note that the operating limitations pursuant to § 91.313, and the noise requirements pursuant to 14 CFR part 36, would apply to this restricted category special purpose operation, unless otherwise waived.

Issued in Washington, DC, on March 5, 2024.

Brian E. Cable,

Manager, Organization and System Policy Branch, Policy and Standards Division, Aircraft Certification Service.

[FR Doc. 2024-04966 Filed 3-7-24; 8:45 am]

BILLING CODE P

DEPARTMENT OF TRANSPORTATION

Federal Aviation Administration

14 CFR Part 39

[Docket No. FAA-2024-0461; Project Identifier AD-2023-00994-E]

RIN 2120-AA64

Airworthiness Directives; CFE Company Engines

AGENCY: Federal Aviation Administration (FAA), DOT.

ACTION: Notice of proposed rulemaking (NPRM).

SUMMARY: The FAA proposes to adopt a new airworthiness directive (AD) for certain CFE Company (CFE) Model CFE738-1-1B engines. This proposed AD was prompted by a manufacturer investigation that revealed certain high-pressure turbine (HPT) stage 1 and stage 2 disks were manufactured from powder metal material suspected to contain iron inclusion. This proposed AD would require replacement of affected HPT stage 1 and stage 2 disks with parts eligible for installation. The FAA is proposing this AD to address the unsafe condition on these products.

DATES: The FAA must receive comments on this proposed AD by April 22, 2024.

ADDRESSES: You may send comments, using the procedures found in 14 CFR 11.43 and 11.45, by any of the following methods:

- *Federal eRulemaking Portal:* Go to [regulations.gov](http://www.regulations.gov). Follow the instructions for submitting comments.

- *Fax:* (202) 493-2251.

- *Mail:* U.S. Department of Transportation, Docket Operations, M-30, West Building Ground Floor, Room W12-140, 1200 New Jersey Avenue SE, Washington, DC 20590.

- *Hand Delivery:* Deliver to Mail address above between 9 a.m. and 5 p.m., Monday through Friday, except Federal holidays.

AD Docket: You may examine the AD docket at [regulations.gov](http://www.regulations.gov) under Docket No. FAA-2024-0461; or in person at Docket Operations between 9 a.m. and 5 p.m., Monday through Friday, except Federal holidays. The AD docket contains this NPRM, any comments received, and other information. The street address for Docket Operations is listed above.

Material Incorporated by Reference:

- For service information identified in this NPRM, contact CFE Company, 111 S. 34th Street, Phoenix, Arizona 85034-2802; phone: (800) 601-3099; website: <https://www.myaerospace.com>.

- You may view this service information at the FAA, Airworthiness Products Section, Operational Safety Branch, 1200 District Avenue, Burlington, MA 01803. For information on the availability of this material at the FAA, call (817) 222-5110.

FOR FURTHER INFORMATION CONTACT: Alexei Marqueen, Aviation Safety Engineer, FAA, 2200 South 216th Street, Des Moines, WA 98198; phone: (781) 238-7178; email: alexei.t.marqueen@faa.gov.

SUPPLEMENTARY INFORMATION:

Comments Invited

The FAA invites you to send any written relevant data, views, or

arguments about this proposal. Send your comments to an address listed under **ADDRESSES**. Include “Docket No. FAA–2024–0461; Project Identifier AD–2023–00994–E” at the beginning of your comments. The most helpful comments reference a specific portion of the proposal, explain the reason for any recommended change, and include supporting data. The FAA will consider all comments received by the closing date and may amend this proposal because of those comments.

Except for Confidential Business Information (CBI) as described in the following paragraph, and other information as described in 14 CFR 11.35, the FAA will post all comments received, without change, to *regulations.gov*, including any personal information you provide. The agency will also post a report summarizing each substantive verbal contact received about this NPRM.

Confidential Business Information

CBI is commercial or financial information that is both customarily and actually treated as private by its owner. Under the Freedom of Information Act (FOIA) (5 U.S.C. 552), CBI is exempt from public disclosure. If your comments responsive to this NPRM contain commercial or financial information that is customarily treated as private, that you actually treat as private, and that is relevant or responsive to this NPRM, it is important that you clearly designate the submitted comments as CBI. Please mark each

page of your submission containing CBI as “PROPIN.” The FAA will treat such marked submissions as confidential under the FOIA, and they will not be placed in the public docket of this NPRM. Submissions containing CBI should be sent to Alexei Marqueen, Aviation Safety Engineer, FAA, 2200 South 216th Street, Des Moines, WA 98198. Any commentary that the FAA receives which is not specifically designated as CBI will be placed in the public docket for this rulemaking.

Background

The FAA was notified by the manufacturer that certain HPT stage 1 and HPT stage 2 disks, installed on certain CFE738–1–1B model engines were manufactured from powder metal material suspected to contain iron inclusion. Further investigation by the manufacturer determined that the iron inclusion is attributed to deficiencies in the manufacturing process and may cause reduced material properties and a lower fatigue life capability, which may result in structural failure. The manufacturer also informed the FAA that additional risk assessments determined that there were no failed events associated with the discovery of this iron inclusion material, however concluded that replacement of the affected HPT stage 1 and HPT stage 2 disks is necessary.

This condition, if not addressed, could result in uncontained debris release, damage to the engine, and damage to the airplane. The FAA is

issuing this AD to address the unsafe condition on these products.

FAA’s Determination

The FAA is issuing this NPRM after determining that the unsafe condition described previously is likely to exist or develop on other products of the same type design.

Related Service Information Under 1 CFR Part 51

The FAA reviewed CFE Service Bulletin (SB) CFE738–72–A8082, dated July 4, 2023 (CFE738–72–A8082), which specifies the affected part and serial numbers of the HPT stage 1 and stage 2 disks and specifies replacement instructions for these affected parts. This service information is reasonably available because the interested parties have access to it through their normal course of business or by the means identified in **ADDRESSES**.

Proposed AD Requirements in This NPRM

This proposed AD would require replacement of certain HPT stage 1 and HPT stage 2 disks with parts eligible for installation.

Costs of Compliance

The FAA estimates that this AD, if adopted as proposed, would affect 29 engines installed on airplanes of U.S. registry.

The FAA estimates the following costs to comply with this proposed AD:

ESTIMATED COSTS

Action	Labor cost	Parts cost	Cost per product	Cost on U.S. operators
Replace HPT stage 1 disk	8 work-hours × \$85 per hour = \$680	\$78,797	\$79,477	\$1,986,925
Replace HPT stage 2 disk	8 work-hours × \$85 per hour = \$680	56,268	56,948	227,792

Authority for This Rulemaking

Title 49 of the United States Code specifies the FAA’s authority to issue rules on aviation safety. Subtitle I, section 106, describes the authority of the FAA Administrator. Subtitle VII: Aviation Programs, describes in more detail the scope of the Agency’s authority.

The FAA is issuing this rulemaking under the authority described in Subtitle VII, Part A, Subpart III, Section 44701: General requirements. Under that section, Congress charges the FAA with promoting safe flight of civil aircraft in air commerce by prescribing regulations for practices, methods, and procedures the Administrator finds necessary for safety in air commerce.

This regulation is within the scope of that authority because it addresses an unsafe condition that is likely to exist or develop on products identified in this rulemaking action.

Regulatory Findings

The FAA determined that this proposed AD would not have federalism implications under Executive Order 13132. This proposed AD would not have a substantial direct effect on the States, on the relationship between the national government and the States, or on the distribution of power and responsibilities among the various levels of government.

For the reasons discussed above, I certify this proposed regulation:

(1) Is not a “significant regulatory action” under Executive Order 12866,

(2) Would not affect intrastate aviation in Alaska, and

(3) Would not have a significant economic impact, positive or negative, on a substantial number of small entities under the criteria of the Regulatory Flexibility Act.

List of Subjects in 14 CFR Part 39

Air transportation, Aircraft, Aviation safety, Incorporation by reference, Safety.

The Proposed Amendment

Accordingly, under the authority delegated to me by the Administrator,

the FAA proposes to amend 14 CFR part 39 as follows:

PART 39—AIRWORTHINESS DIRECTIVES

■ 1. The authority citation for part 39 continues to read as follows:

Authority: 49 U.S.C. 106(g), 40113, 44701.

§ 39.13 [Amended]

■ 2. The FAA amends § 39.13 by adding the following new airworthiness directive:

CFE Company: Docket No. FAA–2024–0461; Project Identifier AD–2023–00994–E.

(a) Comments Due Date

The FAA must receive comments on this airworthiness directive (AD) by April 22, 2024.

(b) Affected ADs

None.

(c) Applicability

This AD applies to CFE Company (CFE) Model CFE738–1–1B engines with an installed high-pressure turbine (HPT) stage 1 disk or HPT stage 2 disk with a part number (P/N) and serial number (S/N) identified in Section 1. Planning Information, paragraph E. Compliance, Tables 2 and 3, of CFE Service Bulletin (SB) CFE738–72–A8082, dated July 4, 2023 (CFE SB CFE738–72–A8082).

(d) Subject

Joint Aircraft System Component (JASC) Code 7250, Turbine Section.

(e) Unsafe Condition

This AD was prompted by a manufacturer investigation that revealed certain HPT stage 1 disks and HPT stage 2 disks were manufactured from powder metal material suspected to contain iron inclusion. The FAA is issuing this AD to prevent premature fracture and consequent uncontained failure. The unsafe condition, if not addressed, could result in uncontained debris release, damage to the engine, and damage to the airplane.

(f) Compliance

Comply with this AD within the compliance times specified, unless already done.

(g) Required Actions

At the applicable times specified in paragraphs (g)(1) and (2) of this AD, remove each affected HPT stage 1 disk and HPT stage 2 disk from service and replace with a part eligible for installation, in accordance with steps (1) through (9) in paragraph B. of the Accomplishment Instructions of CFE SB CFE738–72–A8082.

(1) For affected HPT stage 1 disks, at the next piece part exposure or before exceeding 2,450 cycles since new (CSN), whichever occurs first.

(2) For affected HPT stage 2 disks, at the next piece part exposure or before exceeding 2,930 CSN, whichever occurs first.

(h) Definition

For the purpose of this AD:

(1) A “part eligible for installation” is any HPT stage 1 disk or HPT stage 2 disk with a P/N and S/N that is not identified in Section 1. Planning Information, paragraph E. Compliance, Tables 2 and 3, of CFE SB CFE738–72–A8082.

(2) “Piece-part exposure” is when the affected part is removed from the engine.

(i) Alternative Methods of Compliance (AMOCs)

(1) The Manager, AIR–520 Continued Operational Safety Branch, FAA, has the authority to approve AMOCs for this AD, if requested using the procedures found in 14 CFR 39.19. In accordance with 14 CFR 39.19, send your request to your principal inspector or local Flight Standards District Office, as appropriate. If sending information directly to the manager of the AIR–520 Continued Operational Safety Branch, send it to the attention of the person identified in paragraph (j) of this AD and email to: ANE-AD-AMOC@faa.gov.

(2) Before using any approved AMOC, notify your appropriate principal inspector, or lacking a principal inspector, the manager of the local flight standards district office/certificate holding district office.

(j) Related Information

For more information about this AD, contact Alexei Marqueen, Aviation Safety Engineer, FAA, 2200 South 216th Street, Des Moines, WA 98198; phone: (781) 238–7178; email: alexei.t.marqueen@faa.gov.

(k) Material Incorporated by Reference

(1) The Director of the Federal Register approved the incorporation by reference (IBR) of the service information listed in this paragraph under 5 U.S.C. 552(a) and 1 CFR part 51.

(2) You must use this service information as applicable to do the actions required by this AD, unless the AD specifies otherwise.

(i) CFE Service Bulletin (SB) CFE738–72–A8082, dated July 4, 2023.

(ii) [Reserved]

(3) For service information identified in this AD, contact CFE Company, 111 S. 34th Street, Phoenix, Arizona 85034–2802; phone: (800) 601–3099; website: <https://www.myaerospace.com>.

(4) You may view this service information at FAA, Airworthiness Products Section, Operational Safety Branch, 1200 District Avenue, Burlington, MA 01803. For information on the availability of this material at the FAA, call (817) 222–5110.

(5) You may view this service information that is incorporated by reference at the National Archives and Records Administration (NARA). For information on the availability of this material at NARA, email: fr.inspection@nara.gov, or go to: www.archives.gov/federal-register/cfr/ibr-locations.html.

Issued on March 1, 2024.

Victor Wicklund,

Deputy Director, Compliance & Airworthiness Division, Aircraft Certification Service.

[FR Doc. 2024–04870 Filed 3–7–24; 8:45 am]

BILLING CODE 4910–13–P

ENVIRONMENTAL PROTECTION AGENCY

40 CFR Part 52

[EPA–R09–OAR–2023–0568; FRL–11558–01–R9]

Air Plan Revision: California; South Coast Air Quality Management District

AGENCY: Environmental Protection Agency (EPA).

ACTION: Proposed rule.

SUMMARY: The Environmental Protection Agency (EPA) is proposing to approve revisions to the South Coast Air Quality Management District (SCAQMD) portion of the California State Implementation Plan (SIP). These revisions concern emissions of volatile organic compounds (VOCs) and oxides of nitrogen (NO_x) from refinery flares. We are proposing action on a local rule to regulate these emission sources under the Clean Air Act (CAA or the Act). We are taking comments on this proposal and plan to follow with a final action.

DATES: Comments must be received on or before April 8, 2024.

ADDRESSES: Submit your comments, identified by Docket ID No. EPA–R09–OAR–2023–0568 at <https://www.regulations.gov>. For comments submitted at [Regulations.gov](https://www.regulations.gov), follow the online instructions for submitting comments. Once submitted, comments cannot be edited or removed from [Regulations.gov](https://www.regulations.gov). The EPA may publish any comment received to its public docket. Do not submit electronically any information you consider to be Confidential Business Information (CBI) or other information whose disclosure is restricted by statute. Multimedia submissions (e.g., audio or video) must be accompanied by a written comment. The written comment is considered the official comment and should include discussion of all points you wish to make. The EPA will generally not consider comments or comment contents located outside of the primary submission (i.e., on the web, cloud, or other file sharing system). For additional submission methods, please contact the person identified in the **FOR FURTHER INFORMATION CONTACT** section. For the full EPA public comment policy, information about CBI or multimedia submissions, and general guidance on making effective comments, please visit <https://www.epa.gov/dockets/commenting-epa-dockets>. If you need assistance in a language other than English or if you are a person with a disability who needs a reasonable accommodation at no cost to you, please

contact the person identified in the **FOR FURTHER INFORMATION CONTACT** section.

FOR FURTHER INFORMATION CONTACT:
Donnique Sherman, EPA Region IX, 75 Hawthorne St., San Francisco, CA 94105. By phone: (415) 947-4129 or by email at *sherman.donique@epa.gov*.

SUPPLEMENTARY INFORMATION:
Throughout this document, “we,” “us” and “our” refer to the EPA.

Table of Contents

- I. The State’s Submittal
 - A. What rule did the State submit?
 - B. Are there other versions of this rule?
 - C. What is the purpose of the submitted rule?
- II. The EPA’s Evaluation and Action
 - A. How is the EPA evaluating the rule?
 - B. Does the rule meet the evaluation criteria?
 - C. The EPA’s Recommendations To Further Improve the Rule

- D. Proposed Action and Public Comment
- III. Incorporation by Reference
- IV. Statutory and Executive Order Reviews

I. The State’s Submittal

A. What rule did the State submit?

Table 1 lists the rule addressed by this proposal with the dates that it was adopted by the local air agency and submitted by the California Air Resources Board (CARB).

TABLE 1—SUBMITTED RULE

Local agency	Rule No.	Rule title	Amended	Submitted
SCAQMD	1118	Control of Emissions from Refinery Flares	01/06/23	05/11/23

On November 11, 2023, the submittal for SCAQMD Rule 1118 was deemed by operation of law to meet the completeness criteria in 40 CFR part 51 Appendix V, which must be met before formal EPA review.

B. Are there other versions of this rule?

On September 22, 2022, in a limited approval and limited disapproval action, the EPA finalized inclusion of an earlier version of Rule 1118 into the SIP (87 FR 57838). The SCAQMD adopted revisions to the SIP-approved version of Rule 1118 on January 6, 2023, and CARB submitted them to us on May 11, 2023. If we finalize our proposed approval, the January 6, 2023 version of Rule 1118 will replace the previously approved version of this rule in the SIP.

C. What is the purpose of the submitted rule?

Emissions of NO_x and VOCs contribute to the production of ground-level ozone, smog and particulate matter (PM), which harm human health and the environment. Section 110(a) of the CAA requires states to submit regulations that control NO_x and VOC emissions. Rule 1118 Control of Emissions from Refinery Flares is designed to monitor and record data on refinery and related flaring operations, and to control and minimize flaring and flare related emissions. The EPA’s technical support document (TSD) for this action has more information about this rule.

II. The EPA’s Evaluation and Action

A. How is the EPA evaluating the rule?

Rules in the SIP must be enforceable (see CAA section 110(a)(2)), must not interfere with applicable requirements concerning attainment and reasonable further progress or other CAA requirements (see CAA section 110(l)), and must not modify certain SIP control

requirements in nonattainment areas without ensuring equivalent or greater emissions reductions (see CAA section 193).

Generally, SIP rules must require reasonably available control technology (RACT) for each category of sources covered by a Control Techniques Guidelines (CTG) document as well as each major source of NO_x and VOCs in ozone nonattainment areas classified as moderate or above (see CAA section 182(b)(2)). The SCAQMD regulates an ozone nonattainment area classified as “Extreme” for the 2015 8-hour ozone NAAQS (40 CFR 81.305). Therefore, this rule must ensure the applicable sources implement RACT-level controls for that ozone standard.

Our September 22, 2022 action on Rule 1118 evaluated the rule using this criteria. We finalized a limited approval and limited disapproval of Rule 1118 (amended July 7, 2017) on the basis that the rule allowed the Executive Officer the authority to approve other test methods for determining compliance than those identified in the rule. This deficiency undermined the enforceability of the rule by allowing revisions to the requirements in the SIP without the EPA’s approval. In this current action, Rule 1118 was amended by SCAQMD to solely address the limited disapproval. The changes to Rule 1118 in this submittal have not relaxed or removed any of the main stringency rule provisions, including control requirements, nor have we identified any new information to alter our prior evaluation of Rule 1118. Therefore, our evaluation of the January 6, 2023 amended version of Rule 1118 is focused on the correction of the previously identified deficiency.

Guidance and policy documents that we used to evaluate enforceability and revision/relaxation requirements for the

applicable criteria pollutants include the following:

1. “State Implementation Plans; General Preamble for the Implementation of Title I of the Clean Air Act Amendments of 1990,” 57 FR 13498 (April 16, 1992); 57 FR 18070 (April 28, 1992).
2. “Issues Relating to VOC Regulation Cutpoints, Deficiencies, and Deviations,” EPA, May 25, 1988 (the Bluebook, revised January 11, 1990).
3. “Guidance Document for Correcting Common VOC & Other Rule Deficiencies,” EPA Region 9, August 21, 2001 (the Little Bluebook).

B. Does the rule meet the evaluation criteria?

The revisions to Rule 1118 in this submittal correct the deficiency identified in the EPA’s previous limited approval and limited disapproval of the rule. The new version of Rule 1118 improves the SIP by including the EPA as an approving authority for use of alternative test methods when determining rule compliance. The rule is now largely consistent with CAA requirements and relevant guidance regarding enforceability, RACT, and SIP revisions, and fully approvable.

C. The EPA’s Recommendations To Further Improve the Rule

The TSD includes recommendations for the next time SCAQMD modifies the rule.

D. Public Comment and Proposed Action

As authorized in section 110(k)(3) of the Act, the EPA proposes to fully approve the submitted rule because it fulfill(s) all relevant requirements. We will accept comments from the public on this proposal until April 8, 2024. If we approve the submitted rule in our final action, then will incorporate this rule into the federally enforceable SIP.

III. Incorporation by Reference

In this rule, the EPA is proposing to include in a final EPA rule, regulatory text that includes incorporation by reference. In accordance with requirements of 1 CFR 51.5, the EPA is proposing to incorporate by reference the SCAQMD rule listed in Table 1 of this preamble, which is designed to decrease NO_x and VOC emissions from industries such as petroleum refineries, sulphur recovery plants, and hydrogen production plants by controlling and minimizing flaring and flare related emissions in the South Coast Air Basin. The EPA has made, and will continue to make, these materials available through <https://www.regulations.gov> and at the EPA Region IX Office (please contact the person identified in the **FOR FURTHER INFORMATION CONTACT** section of this preamble for more information).

IV. Statutory and Executive Order Reviews

Under the Clean Air Act, the Administrator is required to approve a SIP submission that complies with the provisions of the Act and applicable federal regulations. 42 U.S.C. 7410(k); 40 CFR 52.02(a). Thus, in reviewing SIP submissions, the EPA's role is to approve state choices, provided that they meet the criteria of the Clean Air Act. Accordingly, this proposed action merely proposes to approve state law as meeting federal requirements and does not impose additional requirements beyond those imposed by state law. For that reason, this proposed action:

- Is not a significant regulatory action subject to review by the Office of Management and Budget under Executive Orders 12866 (58 FR 51735, October 4, 1993) and 14094 (88 FR 21879, April 11, 2023);
- Does not impose an information collection burden under the provisions of the Paperwork Reduction Act (44 U.S.C. 3501 *et seq.*);
- Is certified as not having a significant economic impact on a substantial number of small entities under the Regulatory Flexibility Act (5 U.S.C. 601 *et seq.*);
- Does not contain any unfunded mandate or significantly or uniquely affect small governments, as described in the Unfunded Mandates Reform Act of 1995 (Pub. L. 104–4);
- Does not have federalism implications as specified in Executive Order 13132 (64 FR 43255, August 10, 1999);
- Is not subject to Executive Order 13045 (62 FR 19885, April 23, 1997) because it proposes to approve a state program;

- Is not a significant regulatory action subject to Executive Order 13211 (66 FR 28355, May 22, 2001); and

- Is not subject to requirements of Section 12(d) of the National Technology Transfer and Advancement Act of 1995 (15 U.S.C. 272 note) because application of those requirements would be inconsistent with the Clean Air Act.

In addition, the SIP is not approved to apply on any Indian reservation land or in any other area where the EPA or an Indian tribe has demonstrated that a tribe has jurisdiction. In those areas of Indian country, the rule does not have tribal implications and will not impose substantial direct costs on tribal governments or preempt tribal law as specified by Executive Order 13175 (65 FR 67249, November 9, 2000).

Executive Order 12898 (Federal Actions To Address Environmental Justice in Minority Populations and Low-Income Populations, 59 FR 7629, Feb. 16, 1994) directs Federal agencies to identify and address “disproportionately high and adverse human health or environmental effects” of their actions on minority populations and low-income populations to the greatest extent practicable and permitted by law. The EPA defines environmental justice (EJ) as “the fair treatment and meaningful involvement of all people regardless of race, color, national origin, or income with respect to the development, implementation, and enforcement of environmental laws, regulations, and policies.” The EPA further defines the term fair treatment to mean that “no group of people should bear a disproportionate burden of environmental harms and risks, including those resulting from the negative environmental consequences of industrial, governmental, and commercial operations or programs and policies.”

The State did not evaluate environmental justice considerations as part of its SIP submittal; the CAA and applicable implementing regulations neither prohibit nor require such an evaluation. The EPA did not perform an EJ analysis and did not consider EJ in this action. Consideration of EJ is not required as part of this action, and there is no information in the record inconsistent with the stated goal of Executive Order 12898 of achieving environmental justice for people of color, low-income populations, and Indigenous peoples.

List of Subjects in 40 CFR Part 52

Environmental protection, Air pollution control, Incorporation by reference, Intergovernmental relations, Nitrogen dioxide, Ozone, Particulate

matter, Reporting and recordkeeping requirements, Volatile organic compounds.

Dated: February 29, 2024.

Martha Guzman Aceves,

Regional Administrator, Region IX.

[FR Doc. 2024–04792 Filed 3–7–24; 8:45 am]

BILLING CODE 6560–50–P

ENVIRONMENTAL PROTECTION AGENCY

40 CFR Part 180

[EPA–HQ–OPP–2023–0208; FRL–11678–01–OCSPP]

RIN 2070–ZA16

Tetraacetythylenediamine (TAED), and Its Metabolite Diacetythylenediamine (DAED); Exemption From the Requirement of a Pesticide Tolerance

AGENCY: Environmental Protection Agency (EPA).

ACTION: Proposed rule.

SUMMARY: EPA is proposing to exempt residues of the antimicrobial pesticide ingredient Tetraacetythylenediamine (TAED), including its metabolites and degradates, from the requirement of a tolerance when used on or applied to food contact surfaces in public eating places, dairy processing equipment, and food processing equipment and utensils. This rulemaking is proposed on the Agency's own initiative under the Federal Food, Drug, and Cosmetic Act (FFDCA), in order to implement the tolerance actions EPA identified during its review of these chemicals as part of the Agency's registration review program under the Federal Insecticide, Fungicide, and Rodenticide Act (FIFRA).

DATES: Comments must be received on or before May 7, 2024.

ADDRESSES: Submit your comments, identified by docket identification (ID) number EPA–HQ–OPP–2023–0208, by one of the following methods:

- **Federal eRulemaking Portal:** <https://www.regulations.gov>. Follow the online instructions for submitting comments. Do not submit electronically any information you consider to be Confidential Business Information (CBI) or other information whose disclosure is restricted by statute.

- **Mail:** OPP Docket, Environmental Protection Agency Docket Center (EPA/DC), (28221T), 1200 Pennsylvania Ave. NW, Washington, DC 20460–0001.

- **Hand Delivery:** To make special arrangements for hand delivery or

delivery of boxed information, please follow the instructions at <https://www.epa.gov/dockets>.

Additional instructions on commenting or visiting the docket, along with more information about dockets generally, is available at <https://www.epa.gov/dockets>.

FOR FURTHER INFORMATION CONTACT:

Anita Pease, Antimicrobials Division (7510M), Office of Pesticide Programs, Environmental Protection Agency, 1200 Pennsylvania Ave. NW, Washington, DC 20460-0001; telephone number: (202) 566-0736; email address: pease.anita@epa.gov.

SUPPLEMENTARY INFORMATION:

I. General Information

A. Does this action apply to me?

You may be potentially affected by this action if you are a pesticide manufacturer. The following list of North American Industrial Classification System (NAICS) codes is not intended to be exhaustive, but rather provides a guide to help readers determine whether this document applies to them. Potentially affected entities may include:

- Food manufacturing (NAICS code 311).
- Pesticide manufacturing (NAICS code 32532).
- Restaurant kitchen cleaning services (NAICS code 561720).
- Milk production, dairy cattle (NAICS code 112120).
- Food processing machinery and equipment merchant wholesalers (NAICS code 423830).

B. What should I consider as I prepare my comments for EPA?

1. *Submitting CBI.* Do not submit this information to EPA through [regulations.gov](https://www.regulations.gov) or email. Clearly mark the part or all of the information that you claim to be CBI. In addition to one complete version of the comment that includes information claimed as CBI, a copy of the comment that does not contain the information claimed as CBI must be submitted for inclusion in the public docket. Information so marked will not be disclosed except in accordance with procedures set forth in 40 CFR part 2.

2. *Tips for preparing your comments.* When preparing and submitting your comments, see the commenting tips at <https://www.epa.gov/dockets/commenting-epa-dockets>.

II. Background

A. What action is the Agency taking?

EPA is proposing to establish an exemption from the requirement of a

tolerance for residues of the antimicrobial pesticide tetraacetythylenediamine (TAED) and its metabolites and degradates on food-contact surfaces in public eating places, dairy-processing equipment, and food-processing equipment and utensils.

EPA is proposing this tolerance action to implement the tolerance changes identified as necessary during the registration review processes to cover these pesticide chemical residues when used in antimicrobial formulations consistent with current label use directions. Registration review documents, such as the draft risk assessment, typically identify certain tolerance actions, including modifications to reflect current use patterns, meet safety findings, and change commodity names and groupings that may be necessary or appropriate to cover pesticide chemical residues or reflect current EPA policy.

For the pesticide chemicals at issue in this rulemaking, EPA issued the *TAED Interim Registration Review Decision* (TAED ID) in April 2020. Electronic copies of the TAED ID and other documents are available in EPA docket number EPA-HQ-OPP-2013-0608, which can be found on <https://www.regulations.gov>. EPA's risk assessment for TAED contains the Agency's assessment of the potential risk associated with current product uses, and based on the findings of that risk assessment, the TAED ID identified the need to establish exemptions from the requirement of a tolerance for residues of tetraacetythylenediamine (TAED) when used on or applied to food contact surfaces in public eating places, dairy processing equipment, and food processing equipment and utensils.

B. What is the Agency's authority for taking this action?

Section 408(e) of the FFDCA authorizes EPA to establish exemptions from the requirement of a tolerance. 21 U.S.C. 346a(e)(1)(B). Before issuing the final exemption, EPA is required to issue a proposed rulemaking and provide a comment period of "not less than 60 days". *Id.* at 346a(e)(2).

A "tolerance" represents the maximum level for residues of pesticide chemicals legally allowed in or on raw agricultural commodities and processed foods. Section 408 of FFDCA, 21 U.S.C. 346a, authorizes the establishment, modification, and revocation of tolerances and exemptions from the requirement of a tolerance for residues of pesticide chemicals in or on raw agricultural commodities and processed foods. Residues of pesticides in or on food that are not covered by a tolerance

or exemption are deemed unsafe, 21 U.S.C. 408(a), and any food containing unsafe residues is considered "adulterated" under FFDCA section 402(a), 21 U.S.C. 342(a). Such food may not be distributed in interstate commerce, 21 U.S.C. 331(a). For a food-use pesticide to be sold and distributed in the United States, the pesticide must not only have appropriate tolerances under the FFDCA, but also must be registered under FIFRA, 7 U.S.C. 136 *et seq.* Moreover, residues of food-use pesticides not registered in the United States must also be covered by a U.S. tolerance or exemption in order for commodities treated with those pesticides to be imported into the United States.

Section 408(c)(2)(A)(i) of the FFDCA allows EPA to establish an exemption from the requirement of a tolerance (the legal limit for a pesticide chemical residue in or on a food) only if EPA determines that the tolerance is "safe." Section 408(c)(2)(A)(ii) of the FFDCA defines "safe" to mean that "there is a reasonable certainty that no harm will result from aggregate exposure to the pesticide chemical residue, including all anticipated dietary exposures and all other exposures for which there is reliable information." 21 U.S.C. 346a(c)(2)(A)(ii). This includes exposure through drinking water and in residential settings but does not include occupational exposure. Section 408(c)(2)(B) of the FFDCA requires EPA, when making a safety determination concerning an exemption, to take into account, among other relevant considerations, the considerations listed in section 408(b)(2)(C) and (D) of the FFDCA. Section 408(b)(2)(C) of the FFDCA requires EPA to give special consideration to exposure of infants and children to the pesticide chemical residue in establishing a tolerance and to "ensure that there is a reasonable certainty that no harm will result to infants and children from aggregate exposure to the pesticide chemical residue. . . ." Section 408(b)(2)(D) identifies various factors, including available information on aggregate and cumulative exposure, for EPA consideration in making a safety determination.

C. When do these actions become effective?

EPA is proposing that these tolerance actions become effective on the date of publication of the final rule in the **Federal Register**.

III. Proposed Rule

EPA is proposing this rule to implement the tolerance actions

identified in the TAED ID. EPA, on its own initiative, is proposing to establish the necessary exemption under 40 CFR 180.940(a), which would cover all food-contact uses of tetraacetylenediamine (TAED), from the requirement of a tolerance when used on or applied to food-contact surfaces in public eating places, dairy-processing equipment, and food-processing equipment and utensils.

In order to establish tolerances or exemptions from the requirement of a tolerance, EPA is required to determine that each tolerance or exemption meets the safety standard of FFDCA. In its risk assessment supporting the TAED ID, EPA considered the potential risks from exposure to tetraacetylenediamine (TAED) from registered uses and concluded that those uses did not present risks of concern. See U.S. EPA, Registration Review Draft Risk Assessment for: TAED, available at <https://www.regulations.gov> in docket ID number EPA-HQ-OPP-2013-0608.

IV. Aggregate Risk Assessment and Determination of Safety

Consistent with FFDCA section 408(b)(2)(D), EPA has reviewed the available scientific data and other relevant information in support of this action. EPA has sufficient data to assess the hazards of and to make a determination on aggregate exposure to support the establishment of an exemption from the requirement of a tolerance for residues of tetraacetylenediamine (TAED) and its metabolites and degradates.

EPA has evaluated the available toxicity data and considered its validity, completeness, and reliability as well as the relationship of the results of the studies to human risk. EPA has also considered available information concerning the variability of the sensitivities of major identifiable subgroups of consumers, including infants and children.

Once a pesticide's toxicological profile is determined, EPA identifies toxicological points of departure (POD) and levels of concern to use in evaluating the risk posed by human exposure to the pesticide. For hazards that have a threshold below which there is no appreciable risk, the toxicological POD is used as the basis for derivation of reference values for risk assessment. PODs are developed based on a careful analysis of the doses in each toxicological study to determine the dose at which no adverse effects are observed (the NOAEL) and the lowest dose at which adverse effects of concern are identified (the LOAEL). Uncertainty/safety factors are used in conjunction

with the POD to calculate a safe exposure level—generally referred to as a population-adjusted dose (PAD) or a reference dose (RfD)—and a safe margin of exposure (MOE). For non-threshold risks, the Agency assumes that any amount of exposure will lead to some degree of risk. Thus, the Agency estimates risk in terms of the probability of an occurrence of the adverse effect expected in a lifetime.

EPA's risk assessment for tetraacetylenediamine (TAED), can be found in full at <https://www.regulations.gov> in docket ID number EPA-HQ-OPP-2013-0608. That risk assessment explains EPA's analysis of the toxicity of the pesticide chemicals as well as the selection of toxicological points of departure and levels of concern for use in evaluating the risk posed by human exposure to the pesticide.

TAED exhibits low hazard via the oral route of exposure. The Agency anticipates exposures to negligible levels of TAED residues from food transfer based on the chemical properties and the rapid degradation of the chemical to form peroxyacetic acid (PAA). TAED is a bleach activator and reacts with an oxygen activator (e.g., sodium percarbonate) and undergoes rapid hydrolysis under alkaline conditions to yield PAA, hydrogen peroxide, and diacetylenediamine (DAED). A short-lived, intermediate triacetyl ethylene diamine (triAED) is formed prior to DAED. The remaining acetyl groups on DAED cannot be further displaced by peroxide. TAED is essentially a carrier molecule for PAA, the active moiety. When formed, PAA and hydrogen peroxide are extremely powerful oxidizers and are the active components that will exhibit pesticidal activity.

In addition, EPA's risk assessment considered exposure to TAED based on the maximum label rate for commercial use of TAED as an antimicrobial or biochemical product.

Based on the Agency's risk assessment, no dietary or aggregate risks of concern were identified for tetraacetylenediamine (TAED) or its metabolites or degradates. The physical-chemical properties of both TAED and DAED are very similar and TAED largely metabolizes to DAED *in vivo*. DAED is expected to be of similar or less toxicity than TAED and will be present in reduced quantities compared to TAED. Although TAED use may result in indirect dietary food contact, based on its chemical properties, TAED is expected to rapidly form peracetic acid to impart antimicrobial action needed to disinfect or sanitize surfaces.

Residues of peracetic acid have been determined to be safe, as confirmed by the Peroxy Compounds Registration Review Case. Information regarding the Peroxy Compounds Registration Review Case can be found using docket ID EPA-HQ-OPP-2009-0546 at <https://www.regulations.gov>. Therefore, the Agency anticipates negligible residues to be available for transfer to food and a quantitative chronic dietary exposure and risk assessment was not conducted.

Based on the lack of any aggregate risks of concern, EPA concludes that this exemption from the requirement of a tolerance for residues of TAED, including its metabolites and degradates, is safe, *i.e.*, there is a reasonable certainty that no harm will result from aggregate exposures to TAED, when used in accordance with the terms of the respective exemptions. In addition, due to the lack of toxicity, EPA has determined that there is a reasonable certainty that no harm will result to infants and children from aggregate exposure to the pesticide chemical residues, in accordance with FFDCA section 408(b)(2)(C).

V. Conclusion

Therefore, EPA is proposing to establish an exemption in 40 CFR 180.940(a) for residues of the antimicrobial pesticide ingredient TAED, including its metabolites and degradates, from the requirement of a tolerance when used on or applied to food-contact surfaces in public eating places, dairy-processing equipment, and food-processing equipment and utensils.

VI. Statutory and Executive Order Reviews

In this proposed rule, EPA is proposing to exempt residues of the antimicrobial pesticide ingredient TAED, including its metabolites and degradates, from the requirement of a tolerance under FFDCA section 408(e). The Office of Management and Budget (OMB) has exempted these types of actions (e.g., establishment and modification of a tolerance and tolerance revocation for which extraordinary circumstances do not exist) from review under Executive Order 12866, entitled "Regulatory Planning and Review" (58 FR 51735, October 4, 1993). Because this proposed rule has been exempted from review under Executive Order 12866 due to its lack of significance, this proposed rule is not subject to Executive Order 13211, entitled "Actions Concerning Regulations That Significantly Affect Energy Supply, Distribution, or Use" (66 FR 28355, May 22, 2001). This proposed rule does not contain any information

collections subject to OMB approval under the Paperwork Reduction Act (PRA) (44 U.S.C. 3501 *et seq.*) or impose any enforceable duty or contain any unfunded mandate as described under Title II of the Unfunded Mandates Reform Act (UMRA) (2 U.S.C. 1501 *et seq.*). Nor does it require any special considerations as required by Executive Order 12898, entitled “Federal Actions to Address Environmental Justice in Minority Populations and Low-Income Populations” (59 FR 7629, February 16, 1994); or OMB review or any other Agency action under Executive Order 13045, entitled “Protection of Children from Environmental Health Risks and Safety Risks” (62 FR 19885, April 23, 1997). This proposed rule does not involve any technical standards that would require Agency consideration of voluntary consensus standards pursuant to section 12(d) of the National Technology Transfer and Advancement Act (NTTAA) (15 U.S.C. 272 note). Pursuant to the Regulatory Flexibility Act (RFA) (5 U.S.C. 601 *et seq.*), the Agency previously assessed whether establishment of tolerances, exemptions from tolerances, raising of tolerance levels, expansion of exemptions, or revocations might significantly impact a substantial number of small entities and concluded that, as a general matter, these actions do not impose a significant economic impact on a substantial number of small entities. These analyses for tolerance establishments and modifications, and for tolerance revocations were published in the **Federal Register** of May 4, 1981 (46 FR 24950) and December 17, 1997 (62 FR 66020) (FRL–5753–1), respectively, and were provided to the Chief Counsel for Advocacy of the Small Business Administration. Taking into account this analysis, and available information concerning the pesticides listed in this proposed rule, the Agency hereby certifies that this proposed rule will not have a significant negative economic impact on a substantial number of small entities. Furthermore, for the pesticide named in this proposed rule, the

Agency knows of no extraordinary circumstances that exist as to the present proposed rule that would change EPA’s previous analysis. Any comments about the Agency’s determination should be submitted to the EPA along with comments on the proposed rule and will be addressed prior to issuing a final rule. In addition, the Agency has determined that this proposed rule will not have a substantial direct effect on States, on the relationship between the National Government and the States, or on the distribution of power and responsibilities among the various levels of government, as specified in Executive Order 13132, entitled “Federalism” (64 FR 43255, August 10, 1999). Executive Order 13132, requires EPA to develop an accountable process to ensure “meaningful and timely input by State and local officials in the development of regulatory policies that have federalism implications.” “Policies that have federalism implications” is defined in the Executive order to include regulations that have “substantial direct effects on the States, on the relationship between the National Government and the States, or on the distribution of power and responsibilities among the various levels of government.” This proposed rule directly regulates growers, food processors, food handlers, and food retailers, not States. This proposed rule does not alter the relationships or distribution of power and responsibilities established by Congress in the preemption provisions of FFDCA section 408(n)(4). For these same reasons, the Agency has determined that this proposed rule does not have any “tribal implications” as described in Executive Order 13175 entitled “*Consultation and Coordination with Indian Tribal Governments*” (65 FR 67249, November 9, 2000). Executive Order 13175, requires EPA to develop an accountable process to ensure “meaningful and timely input by tribal officials in the development of regulatory policies that have tribal

implications.” “Policies that have tribal implications” is defined in the Executive order to include regulations that have “substantial direct effects on one or more Indian tribes, on the relationship between the Federal Government and the Indian tribes, or on the distribution of power and responsibilities between the Federal Government and Indian tribes.” This proposed rule will not have substantial direct effects on tribal governments, on the relationship between the Federal Government and Indian tribes, or on the distribution of power and responsibilities between the Federal Government and Indian tribes, as specified in Executive Order 13175. Thus, Executive Order 13175, does not apply to this proposed rule.

List of Subjects in 40 CFR Part 180

Environmental protection, Administrative practice and procedure, Agricultural commodities, Pesticides and pests, Reporting and recordkeeping requirements.

Dated: February 29, 2024.

Michael Goodis,
Deputy Director, Office of Pesticide Programs.

Therefore, it is proposed that 40 CFR chapter I be amended as follows:

PART 180—TOLERANCES AND EXEMPTIONS FOR PESTICIDE CHEMICAL RESIDUES IN FOOD

■ 1. The authority citation for part 180 continues to read as follows:

Authority: 21 U.S.C. 321(q), 346a and 371.

■ 2. In § 180.940, amend table 1 to paragraph (a) by adding, in alphabetical order, an entry for “Tetraacetythylenediamine (TAED)” to read as follows:

§ 180.940 Tolerance exemptions for active and inert ingredients for use in antimicrobial formulations (Food-contact surface sanitizing solutions).

* * * * *

TABLE 1 TO PARAGRAPH (a)

Pesticide chemical	CAS reg. No.	Limits
* * * * *	* * * * *	* * * * *
Tetraacetythylenediamine (TAED)	10543–57–4	None.
* * * * *	* * * * *	* * * * *

Notices

Federal Register

Vol. 89, No. 47

Friday, March 8, 2024

This section of the FEDERAL REGISTER contains documents other than rules or proposed rules that are applicable to the public. Notices of hearings and investigations, committee meetings, agency decisions and rulings, delegations of authority, filing of petitions and applications and agency statements of organization and functions are examples of documents appearing in this section.

DEPARTMENT OF AGRICULTURE

Forest Service

Flathead Resource Advisory Committee

AGENCY: Forest Service, Agriculture (USDA).

ACTION: Notice of meeting.

SUMMARY: The Flathead Resource Advisory Committee (RAC) will hold a public meeting according to the details shown below. The committee is authorized under the Secure Rural Schools and Community Self-Determination Act (the Act) and operates in compliance with the Federal Advisory Committee Act (FACA). The purpose of the committee is to improve collaborative relationships and to provide advice and recommendations to the Forest Service concerning projects and funding consistent with Title II of the Act as well as to make recommendations on recreation fee proposals for sites on the Flathead National Forest within Flathead County, consistent with the Federal Lands Recreation Enhancement Act.

DATES: An in-person and virtual meeting will be held on April 18, 2024, 4:30 p.m.–6:30 p.m. Mountain Daylight Time (MDT) and April 23, 2024, 4:30 p.m.–6:30 p.m. MDT.

Written and Oral Comments: Anyone wishing to provide in-person and/or virtual oral comments must pre-register by 11:59 p.m. MDT on April 17, 2024. Written public comments will be accepted by 11:59 p.m. MDT on April 17, 2024. Comments submitted after this date will be provided to the Forest Service, but the committee may not have adequate time to consider those comments prior to the meeting.

All RAC meetings are subject to cancellation. For status of the meeting prior to attendance, please contact the person listed under **FOR FURTHER INFORMATION CONTACT**.

ADDRESSES: This meeting will be held in-person and virtually at the Flathead National Forest Supervisor's Office located at 650 Wolfpack Way, Kalispell, Montana 59901. The public may also join virtually via webcast, teleconference, videoconference and/or Homeland Security Information Network (HSIN) virtual meeting at: https://teams.microsoft.com/l/meetup-join/19%3ameeting_ODBkY2QzNmYtMjM3Ni00ZTE2LWFIN2U?tZjl5ZGU5NTE5MTM4%40thread.v2/0?context=%7b%22Tid%22%3a%22ed5b36e7-01ee-4ebc-867e-e03cfa0d4697%22%2c%22Oid%22%3a%229bc77679-0992-4906-85db-2a15fa3e7761%22%7d; meeting ID: 294 729 726 451; Passcode: 3hqXGu. This link will be good for both meeting dates. RAC information and meeting details can be found at the following website: <https://www.fs.usda.gov/main/flathead/workingtogether/advisorycommittees> or by contacting the person listed under **FOR FURTHER INFORMATION CONTACT**.

Written Comments: Written comments must be sent by email to ivy.gehling@usda.gov or via mail (*i.e.*, postmarked) to Ivy Gehling, 650 Wolfpack Way, Kalispell, Montana 59901. The Forest Service strongly prefers comments be submitted electronically.

Oral Comments: Persons or organizations wishing to make oral comments must pre-register by 11:59 p.m. MDT, April 17, 2024, and speakers can only register for one speaking slot. Oral comments must be sent by email to ivy.gehling@usda.gov or via mail (*i.e.*, postmarked) to Ivy Gehling, 650 Wolfpack Way, Kalispell, Montana 59901.

FOR FURTHER INFORMATION CONTACT: Tad Wehunt, Designated Federal Officer (DFO), by phone at 406–758–5280 or email at william.wehunt@usda.gov or Ivy Gehling, RAC Coordinator, at 406–758–5251 or email at ivy.gehling@usda.gov.

SUPPLEMENTARY INFORMATION: The purpose of the meetings are to:

1. Hear from Title II project proponents and discuss Title II project proposals;
2. Make funding recommendations on Title II projects;
3. Approve meeting minutes;
4. Schedule the next meeting; and
5. Other.

The agenda will include time for individuals to make oral statements of three minutes or less. Individuals wishing to make an oral statement should make a request in writing at least three days prior to the meeting date to be scheduled on the agenda. Written comments may be submitted to the Forest Service up to 14 days after the meeting date listed under **DATES**.

Please contact the person listed under **FOR FURTHER INFORMATION CONTACT**, by or before the deadline, for all questions related to the meeting. All comments, including names and addresses when provided, are placed in the record and are available for public inspection and copying. The public may inspect comments received upon request.

Meeting Accommodations: The meeting location is compliant with the Americans with Disabilities Act, and the USDA provides reasonable accommodation to individuals with disabilities where appropriate. If you are a person requiring reasonable accommodation, please make requests in advance for sign language interpretation, assistive listening devices, or other reasonable accommodation to the person listed under the **FOR FURTHER INFORMATION CONTACT** section, USDA's TARGET Center at (202) 720–2600 (voice and TTY) or USDA through the Federal Relay Service at (800) 877–8339. Additionally, program information may be made available in languages other than English.

USDA programs are prohibited from discriminating based on race, color, national origin, religion, sex, gender identity (including gender expression), sexual orientation, disability, age, marital status, family/parental status, income derived from a public assistance program, political beliefs, or reprisal or retaliation for prior civil rights activity, in any program or activity conducted or funded by USDA (not all bases apply to all programs). Remedies and complaint filing deadlines vary by program or incident.

Equal opportunity practices in accordance with USDA's policies will be followed in all appointments to the committee. To ensure that the recommendations of the committee have taken in account the needs of the diverse groups served by USDA, membership shall include to the extent possible, individuals with demonstrated

ability to represent minorities, women, and persons with disabilities. USDA is an equal opportunity provider, employer, and lender.

Dated: March 5, 2024.

Cikena Reid,

USDA Committee Management Officer.

[FR Doc. 2024-04995 Filed 3-7-24; 8:45 am]

BILLING CODE 3411-15-P

DEPARTMENT OF AGRICULTURE

Forest Service

North Wisconsin Resource Advisory Committee

AGENCY: Forest Service, Agriculture (USDA).

ACTION: Notice of meeting.

SUMMARY: The North Wisconsin Resource Advisory Committee (RAC) will hold a public meeting according to the details shown below. The committee is authorized under the Secure Rural Schools and Community Self-Determination Act (the Act) and operates in compliance with the Federal Advisory Committee Act (FACA). The purpose of the committee is to improve collaborative relationships and to provide advice and recommendations to the Forest Service concerning projects and funding consistent with Title II of the Act as well as to make recommendations on recreation fee proposals for sites on the Chequamegon-Nicolet National Forest within Ashland, Bayfield, Florence, Forest, Langlade, Oconto, Price, Sawyer, Taylor, and Vilas Counties, consistent with the Federal Lands Recreation Enhancement Act.

DATES: An in-person and/or virtual meeting will be held on April 23, 2024, 9 a.m.–3 p.m., Central Daylight Time (CDT).

Written and Oral Comments: Anyone wishing to provide in-person and/or virtual oral comments must pre-register by 11:59 p.m. CDT on April 18, 2024. Written public comments will be accepted by 11:59 p.m. CDT on April 18, 2024. Comments submitted after this date will be provided to the Forest Service, but the committee may not have adequate time to consider those comments prior to the meeting.

All RAC meetings are subject to cancellation. For status of the meeting prior to attendance, please contact the person listed under **FOR FURTHER INFORMATION CONTACT**.

ADDRESSES: This meeting will be held in-person and/or virtually at the Rhinelander Supervisor's Office located at 500 Hanson Lake Road, Rhinelander, Wisconsin 54501. The public may also

join virtually via teleconference and/or videoconference. RAC information and meeting details can be found at the following website: <https://www.fs.usda.gov/main/cnnf/workingtogether/advisorycommittees> or by contacting the person listed under **FOR FURTHER INFORMATION CONTACT**.

Written Comments: Written comments must be sent by email to adam.felts@usda.gov or via mail (*i.e.*, postmarked) to Chequamegon-Nicolet National Forest, ATTN: Adam Felts, 500 Hanson Lake Road, Rhinelander, Wisconsin 54501. The Forest Service strongly prefers comments be submitted electronically.

Oral Comments: Persons or organizations wishing to make oral comments must pre-register by 11:59 p.m. CDT, April 18, 2024, and speakers can only register for one speaking slot. Oral comments must be sent by email to adam.felts@usda.gov or via mail (*i.e.*, postmarked) to Adam Felts, 500 Hanson Lake Road, Rhinelander, Wisconsin 54501.

FOR FURTHER INFORMATION CONTACT: Adam Felts, Designated Federal Officer (DFO), by phone at 715-362-1335 or email at adam.felts@usda.gov.

SUPPLEMENTARY INFORMATION: The purpose of the meeting is to:

1. Elect a Chairperson;
2. Hear from Title II project proponents and discuss Title II project proposals;
3. Make funding recommendations on Title II projects;
4. Hear from the Forest Service and discuss recreation fee proposals; and
5. Make recommendations on recreation fee proposals.

The agenda will include time for individuals to make oral statements of three minutes or less. Individuals wishing to make an oral statement should make a request in writing at least three days prior to the meeting date to be scheduled on the agenda. Written comments may be submitted to the Forest Service up to 14 days after the meeting date listed under **DATES**.

Please contact the person listed under **FOR FURTHER INFORMATION CONTACT**, by or before the deadline, for all questions related to the meeting. All comments, including names and addresses when provided, are placed in the record and are available for public inspection and copying. The public may inspect comments received upon request.

Meeting Accommodations: The meeting location is compliant with the Americans with Disabilities Act, and the USDA provides reasonable accommodation to individuals with disabilities where appropriate. If you are

a person requiring reasonable accommodation, please make requests in advance for sign language interpretation, assistive listening devices, or other reasonable accommodation to the person listed under the **FOR FURTHER INFORMATION CONTACT** section or contact USDA's TARGET Center at (202) 720-2600 (voice and TTY) or USDA through the Federal Relay Service at (800) 877-8339. Additionally, program information may be made available in languages other than English.

USDA programs are prohibited from discriminating based on race, color, national origin, religion, sex, gender identity (including gender expression), sexual orientation, disability, age, marital status, family/parental status, income derived from a public assistance program, political beliefs, or reprisal or retaliation for prior civil rights activity, in any program or activity conducted or funded by USDA (not all bases apply to all programs). Remedies and complaint filing deadlines vary by program or incident.

Equal opportunity practices in accordance with USDA's policies will be followed in all appointments to the committee. To ensure that the recommendations of the committee have taken in account the needs of the diverse groups served by USDA, membership shall include to the extent possible, individuals with demonstrated ability to represent minorities, women, and persons with disabilities. USDA is an equal opportunity provider, employer, and lender.

Dated: March 5, 2024.

Cikena Reid,

USDA Committee Management Officer.

[FR Doc. 2024-04994 Filed 3-7-24; 8:45 am]

BILLING CODE 3411-15-P

DEPARTMENT OF AGRICULTURE

Rural Utilities Service

[Docket No.: RUS-24-WATER-0006]

60-Day Notice of Proposed Information Collection: Grant Program To Establish a Revolving Fund Program (RFP) To Finance Water and Wastewater Projects, 7 CFR 1783; OMB Control No.: 0572-0138

AGENCY: Rural Utilities Service (RUS), USDA.

ACTION: Notice; request for comment.

SUMMARY: In accordance with the Paperwork Reduction Act of 1995, as amended, the United States Department of Agriculture (USDA) Rural Utilities

Service (RUS) announces its intention to request a revision of a currently approved information collection and invites comments on this information collection.

DATES: Comments on this notice must be received by May 7, 2024, to be assured of consideration.

ADDRESSES: Comments may be submitted by the Federal eRulemaking Portal: Go to <http://www.regulations.gov> and, in the "Search Field" box, labeled "Search for dockets and documents on agency actions," enter the following docket number: (RHS-24-WATER-0006), and click "Search." To submit public comments, select the "Comment" button. Before inputting your comments, you may also review the "Commenter's Checklist" (optional). Insert your comments under the "Comment" title, click "Browse" to attach files (if applicable). Input your email address and select an identity category then click "Submit Comment." Information on using *Regulations.gov*, including instructions for accessing documents, submitting comments, and viewing the docket after the close of the comment period, is available through the site's "FAQ" link.

FOR FURTHER INFORMATION CONTACT: MaryPat Daskal, Chief, Branch 1, Rural Development Innovation Center—Regulations Management Division, USDA, 1400 Independence Avenue SW, STOP 1522, South Building, Washington, DC 20250-1522. Telephone: (202) 720-7853. Email MaryPat.Daskal@usda.gov.

SUPPLEMENTARY INFORMATION: The Office of Management and Budget's (OMB) regulation (5 CFR 1320) implementing provisions of the Paperwork Reduction Act of 1995 (Pub. L. 104-13) requires that interested members of the public and affected agencies have an opportunity to comment on information collection and recordkeeping activities (see 5 CFR 1320.8(d)). This notice identifies an information collection that RHS is submitting to OMB for revision.

Title: Grant Program to Establish a Revolving Fund Program (RFP) to Finance Water and Wastewater Projects, 7 CFR 1783.

OMB Control Number: 0572-0138.

Expiration Date of Approval: July 31, 2024.

Type of Request: Revision of a currently approved information collection.

Estimate of Burden: Public reporting burden for this collection of information is estimated to average 7.30 hour per response.

Respondents: Individuals, partnerships, public and private non-

profit corporations, agencies, institutions, organizations, and Indian tribes.

Estimated Number of Respondents: 4.

Estimated Number of Responses: 51.

Estimated Number of Responses per Respondent: 12.75.

Estimated Annual Reporting Burden on Respondents: 372.50 hours.

Abstract: The Rural Utilities Service (RUS) supports the sound development of rural communities and the growth of our economy without endangering the environment. One of the ways the Agency pursues this goal is to provide financial and technical assistance to help communities bring safe drinking water and sanitary, environmentally sound waste disposal facilities to rural Americans in greatest need. The Revolving Fund Program (RFP) helps qualified non-profits create a revolving loan fund that can provide financing for the extension and improvement of water and waste disposal systems in rural areas. Entities eligible for the revolving loan fund will be the same entities eligible to obtain a loan, loan guarantee, or grant from RUS Water and Waste Disposal and Wastewater loan and grant programs. As grant recipients, the non-profit organizations establish a revolving loan fund to provide loans to finance predevelopment costs of water or wastewater projects, or short-term small capital projects not part of the regular operation and maintenance of current water and wastewater systems. The collection of information consists of the materials to file a grant application with the agency, including forms, certifications and required documentation.

Comments are invited on: (a) whether the proposed collection of information is necessary for the proper performance of the functions of the Agency, including whether the information will have practical utility; (b) the accuracy of the Agency's estimate of the burden of the proposed collection of information including the validity of the methodology and assumptions used; (c) ways to enhance the quality, utility and clarity of the information to be collected; and (d) ways to minimize the burden of the collection of information on those who are to respond, including through the use of appropriate automated, electronic, mechanical, or other technological collection techniques or other forms of information technology. Comments may be sent by the Federal eRulemaking Portal: Go to <https://www.regulations.gov>. Follow the instructions for submitting comments.

Copies of this information collection can be obtained from Kimble Brown, Rural Development Innovation Center,

USDA, 1400 Independence Avenue SW, STOP 1522, South Building, Washington, DC 20250-1522. Telephone: (202) 720-6780. Email kimble.brown@usda.gov.

All responses to this notice will be summarized and included in the request for OMB approval. All comments will also become a matter of public record.

Andrew Berke,

Administrator, Rural Utilities Service.

[FR Doc. 2024-04944 Filed 3-7-24; 8:45 am]

BILLING CODE 3410-15-P

DEPARTMENT OF COMMERCE

Census Bureau

Agency Information Collection Activities; Submission to the Office of Management and Budget (OMB) for Review and Approval; Comment Request; Collection of State/Local Administrative Records and Third-Party Data

AGENCY: Census Bureau, Department of Commerce.

ACTION: Notice of information collection, request for comment.

SUMMARY: The Department of Commerce, in accordance with the Paperwork Reduction Act (PRA) of 1995, invites the general public and other Federal agencies to comment on proposed, and continuing information collections, which helps us assess the impact of our information collection requirements and minimize the public's reporting burden. The purpose of this notice is to allow for 60 days of public comment on the proposed new information collection, prior to the submission of the information collection request (ICR) to OMB for approval.

DATES: To ensure consideration, comments regarding this proposed information collection must be received on or before May 7, 2024.

ADDRESSES: Interested persons are invited to submit written comments by email to Thomas.J.Smith@census.gov. Please reference 'Collection of State Administrative Records and Third-Party Data' in the subject line of your comments. You may also submit comments, identified by Docket Number USBC-2024-0005, to the Federal e-Rulemaking Portal: <http://www.regulations.gov>. All comments received are part of the public record. No comments will be posted to <http://www.regulations.gov> for public viewing until after the comment period has closed. Comments will generally be posted without change. All Personally

Identifiable Information (for example, name and address) voluntarily submitted by the commenter may be publicly accessible. Do not submit Confidential Business Information or otherwise sensitive or protected information. You may submit attachments to electronic comments in Microsoft Word, Excel, or Adobe PDF file formats.

FOR FURTHER INFORMATION CONTACT: Requests for additional information or specific questions related to collection activities should be directed to Jenny Aramony, Chief of the Data Acquisition Branch in the Economic Reimbursable Surveys Division, email at adm.pra@census.gov and phone number (301) 763-8715.

SUPPLEMENTARY INFORMATION:

I. Abstract

The U.S. Census Bureau plans to request a new clearance for acquiring administrative records including State, local, and third-party data to improve efficiency and accuracy in their data collections, and to improve measures of the population and economy.

The Census Bureau uses State and local administrative records data linked with other survey and census records, including but not limited to, data from the Survey of Income and Program Participation (SIPP), the Current Population Survey (CPS) and the American Community Survey (ACS) to conduct research and improve operations. The Census Bureau encourages the District of Columbia, all 50 States, and local municipalities to share administrative records data generally associated with, but not limited to: nutrition and food assistance programs, including the Supplemental Nutrition Assistance Program (SNAP) and the Special Supplemental Nutrition Program for Women, Infants and Children (WIC); and welfare programs, including child care subsidy; household self-sufficiency programs, including low income energy assistance programs and Temporary Assistance for Needy Families (TANF). Data sharing and analysis of linked files are solely for statistical purposes, not for program enforcement. All State and local administrative records data are and will remain confidential under title 13, United States Code, section 9, whether in their original form or when comingled or linked.

The Census Bureau will use data from businesses for research, censuses, and surveys operations. This data will be collected from businesses through agreements or contracts. Third-party targeted entities for this acquisition will

include cross sector industries such as manufacturing, information services, healthcare, supply chain, and retail.

The Census Bureau uses these records to improve data quality, produce modelbased estimates, improve edits and allocations, and to study program participation over time. The data is to support all the Census Bureau survey and decennial operations as well as social economic research through record linkage. The Census Bureau has undertaken research projects to integrate and link State, local, and third-party administrative records with Census Bureau data from current surveys and censuses.

The Census Bureau uses the State and local administrative records and third-party data linked with other survey and census records to conduct further research and improve operations in surveys and censuses, including 2030 Census Operations. The Census Bureau benefits from these projects by improving data quality and estimates, as well as studies of program participation over time. State and local municipalities data and third-party providers have benefited through access to tabulated data and reports to better understand the demographic characteristics of program participants and to administer their programs.

II. Method of Collection

The Census Bureau will contact the State agencies and third-party providers to discuss how the Census Bureau might use State administrative records and third-party data. After entering into a data sharing agreement with the Census Bureau, a State agency, local municipality, or third-party provider would transfer the agreed-upon administrative records to the Census Bureau via secure File Transfer Protocol or encrypted CD-ROM or DVD-ROM.

Linking records across programs, across States, local municipalities, and third-parties, or over time will be accomplished using a unique linkage identifier called a Protected Identification Key (PIK). Processing to assign a PIK to each person record involves matching based on combinations of name, address, sex, date of birth, and Social Security Number (SSN) data, as available. The person validation and PIK processing has been used by other Census Bureau research and operations projects. Only Census Bureau staff conducting the record linkage have access to files with Personally Identifiable Information, and access to those files assigned a PIK is limited to individuals with a need to know who have met the requirements of

Title 13, United States Code, and have appropriate security clearances.

III. Data

OMB Control Number: 0607-XXXX.

Form Number(s): Information will be collected in the form of a data transfer to the Census Bureau. No form will be used.

Type of Review: Regular submission, new information collection request.

Affected Public: State, local, or Tribal government, and third-party providers.

Estimated Number of Respondents: 80 including 19 third-party providers, 10 local municipalities, 50 States and the District of Columbia.

Estimated Time per Response: 75 hours.

Estimated Total Annual Burden Hours: 6,000.

Estimated Total Annual Cost to Public: \$0. (This is not the cost of respondents' time, but the indirect costs respondents may incur for such things as purchases of specialized software or hardware needed to report, or expenditures for accounting or records maintenance services required specifically by the collection.)

Respondent's Obligation: Voluntary.

Legal Authority: Title 13 U.S.C. 6.

IV. Request for Comments

We are soliciting public comments to permit the Department/Bureau to: (a) Evaluate whether the proposed information collection is necessary for the proper functions of the Department, including whether the information will have practical utility; (b) Evaluate the accuracy of our estimate of the time and cost burden for this proposed collection, including the validity of the methodology and assumptions used; (c) Evaluate ways to enhance the quality, utility, and clarity of the information to be collected; and (d) Minimize the reporting burden on those who are to respond, including the use of automated collection techniques or other forms of information technology.

Comments that you submit in response to this notice are a matter of public record. We will include, or summarize, each comment in our request to OMB to approve this ICR. Before including your address, phone number, email address, or other personal identifying information in your comment, you should be aware that your entire comment—including your personal identifying information—may be made publicly available at any time. While you may ask us in your comment to withhold your personal identifying information from public review, we

cannot guarantee that we will be able to do so.

Sheleen Dumas,

Department PRA Clearance Officer, Office of the Under Secretary for Economic Affairs, Commerce Department.

[FR Doc. 2024-04998 Filed 3-7-24; 8:45 am]

BILLING CODE 3510-07-P

DEPARTMENT OF COMMERCE

Census Bureau

Agency Information Collection Activities; Submission to the Office of Management and Budget (OMB) for Review and Approval; Comment Request; Quarterly Summary of State & Local Government Tax Revenues

The Department of Commerce will submit the following information collection request to the Office of Management and Budget (OMB) for review and clearance in accordance with the Paperwork Reduction Act of 1995, on or after the date of publication of this notice. We invite the general public and other Federal agencies to comment on proposed, and continuing information collections, which helps us assess the impact of our information collection requirements and minimize the public's reporting burden. Public comments were previously requested via the **Federal Register** on December 8, 2023 during a 60-day comment period. This notice allows for an additional 30 days for public comments.

Agency: U.S. Census Bureau, Department of Commerce.

Title: Quarterly Summary of State & Local Government Tax Revenues.

OMB Control Number: 0607-0112.

Form Number(s): F-71, F-72, F-73.

Type of Request: Regular submission, Request for an Extension, without Change, of a Currently Approved Collection.

Number of Respondents: 7,411.

Average Hours per Response: 16.36 minutes.

Burden Hours: 8,082.

Needs and Uses: The Census Bureau conducts the Quarterly Summary of State & Local Government Tax Revenues (QTax Survey) to provide quarterly estimates of State and local government tax revenue at a national level, as well as detailed tax revenue data for individual States. The Census Bureau is requesting an extension of the current clearance for this survey without changes to the forms. Quarterly measurement of, and reporting on, these fund flows provides valuable insight into trends in the national economy and that of individual States. Information

collected on the type and quantity of taxes collected gives comparative data on how the various levels of government fund their public sector obligations. There are three components to the QTax Survey; the first component is the Quarterly Survey of Property Tax Collections (F-71), which collects property tax data from local governments, the second component is the Quarterly Survey of State Tax Collections (F-72), which collects data on 28 different tax categories for all 50 States, and the third component is the Quarterly Survey of Selected Non-Property Taxes (F-73), which collects local tax revenue data for three taxes: sales and gross receipts, individual income, and corporation net income taxes.

The information contained in this survey is the most current information available on a nationwide basis for State and local government tax collections. Data are collected for fifty State governments and the District of Columbia and a sample of the local governments (approximately 7,411).

The Census Bureau's previous request for an extension submitted on 03/23/2021 requested approval to remove the collection of all license taxes from the F-72 component of the Quarterly Summary of State and Local Government Tax Revenue. The Census Bureau reconsidered that plan and decided not to remove the collection of all license taxes from the F-72 component of the survey. Keeping the license taxes on the survey allows for a consistent time series and maintains item comparability with other surveys.

The Census Bureau conducts the three components of the QTax Survey to collect State and local government tax data for this data series established in 1962. It serves as a timely source of tax data for many data users and policy makers and is the most current information available on a nationwide basis for government tax collections. Tax collection data are used to measure economic activity nationwide, as well as for comparison among the States. These data are also used in comparing the variety of taxes employed by individual States and in determining the revenue raising capacity of different types of taxes in different States.

Key users of these data include the Bureau of Economic Analysis (BEA), the Federal Reserve Board (FRB), and the Department of Housing and Urban Development (HUD) who rely on these data to provide they provide insight into and the most current information on the complex nature and fiscal health of State and local government finances. These data are included in the quarterly

estimates of the National Income and Product Accounts developed by BEA. HUD has used the property tax data as one of nine cost indicators for developing Section 8 rent adjustments. These data are widely used by Federal, State, and local legislators, policy makers, analysts, economists, and researchers to follow the changing characteristics and monitor trends in public sector revenues. These data are also widely used by the media and academia.

Frequency: Quarterly.

Respondent's Obligation: Voluntary.

Legal Authority: Title 13 U.S.C., sections 161 and 182.

This information collection request may be viewed at www.reginfo.gov. Follow the instructions to view the Department of Commerce collections currently under review by OMB.

Written comments and recommendations for the proposed information collection should be submitted within 30 days of the publication of this notice on the following website www.reginfo.gov/public/do/PRAMain. Find this particular information collection by selecting "Currently under 30-day Review—Open for Public Comments" or by using the search function and entering either the title of the collection or the OMB Control Number 0607-0112.

Sheleen Dumas,

Department PRA Clearance Officer, Office of the Under Secretary for Economic Affairs, Commerce Department.

[FR Doc. 2024-05001 Filed 3-7-24; 8:45 am]

BILLING CODE 3510-07-P

DEPARTMENT OF COMMERCE

Census Bureau

Agency Information Collection Activities; Submission to the Office of Management and Budget (OMB) for Review and Approval; Comment Request; Business and Professional Classification Report

AGENCY: Census Bureau, Department of Commerce.

ACTION: Notice of information collection, request for comment.

SUMMARY: The Department of Commerce, in accordance with the Paperwork Reduction Act (PRA) of 1995, invites the general public and other Federal agencies to comment on proposed, and continuing information collections, which helps us assess the impact of our information collection requirements and minimize the public's reporting burden. The purpose of this

notice is to allow for 60 days of public comment on the proposed extension of the Business and Professional Classification Report prior to the submission of the information collection request (ICR) to OMB for approval.

DATES: To ensure consideration, comments regarding this proposed information collection must be received on or before May 7, 2024.

ADDRESSES: Interested persons are invited to submit written comments by email to *Thomas.J.Smith@census.gov*. Please reference Business and Professional Classification Report in the subject line of your comments. You may also submit comments, identified by Docket Number USBC–2024–0004, to the Federal e-Rulemaking Portal: <https://www.regulations.gov>. All comments received are part of the public record. No comments will be posted to <https://www.regulations.gov> for public viewing until after the comment period has closed. Comments will generally be posted without change. All Personally Identifiable Information (for example, name and address) voluntarily submitted by the commenter may be publicly accessible. Do not submit Confidential Business Information or otherwise sensitive or protected information. You may submit attachments to electronic comments in Microsoft Word, Excel, or Adobe PDF file formats.

FOR FURTHER INFORMATION CONTACT: Requests for additional information or specific questions related to collection activities should be directed to Scott Handmaker, Branch Chief, Classification Processing Branch, Economic Statistical Methods Division, (301) 763–7107, and *Scott.P.Handmaker@census.gov*.

SUPPLEMENTARY INFORMATION:

I. Abstract

The Census Bureau conducts the Business and Professional Classification Report to collect information from new businesses to obtain proper industry classification for use in economic surveys and the Economic Census. The survey, conducted quarterly with new respondents each quarter, samples businesses with newly assigned Employer Identification Numbers (EINs) from the Internal Revenue Service (IRS). Businesses can only be selected once for the survey. The survey collects data about a business in such areas as: primary business activity, company structure, size, and business operations. This information is used to update the sampling frame for current business surveys, which ensures high quality economic estimates. Additionally, by ensuring proper industry classification,

this survey reduces burden for the businesses in the five-year Economic Census, as the questions in the census are tailored to the industry in which the business operates.

Respondents will choose the economic sector of their business and then select from a list of business activities. If the respondent does not see their business activity listed, then they will provide a brief description of their business activity. This is the same methodology that the Census Bureau uses in the Economic Census to assign industry classification.

Minimal, non-substantive changes will be made to the wording and organization of existing questions and instructions.

II. Method of Collection

The Business and Professional Classification Report is primarily collected via the internet and telephone follow-up. Those selected for the survey receive an initial letter informing the respondents of their requirement to complete the survey as well as instructions on accessing the survey. Responses will be due approximately 30 days from initial mailing. Respondents will also receive a due date reminder approximately one week before responses are due. After the due date, an overdue notice is sent to nonrespondents. Lastly, the Census Bureau will conduct telephone and email follow-up operations for nonresponse. Throughout the survey, telephone assistance is available for respondents with questions and for those that cannot report over the internet.

III. Data

OMB Control Number: 0607–0189.

Form Number(s): SQ–CLASS.

Type of Review: Regular submission, Request for an extension, without change of a currently approved collection.

Affected Public: Business or other for profit and not-for-profit institutions.

Estimated Number of Respondents: 60,000 annually.

Estimated Time per Response: 13 minutes.

Estimated Total Annual Burden Hours: 13,000.

Estimated Total Annual Cost to Public: \$0. (This is not the cost of respondents' time, but the indirect costs respondents may incur for such things as purchases of specialized software or hardware needed to report, or expenditures for accounting or records maintenance services required specifically by the collection.)

Respondent's Obligation: Mandatory.

Legal Authority: Title 13, United States Code, sections 131, 182 and 193.

IV. Request for Comments

We are soliciting public comments to permit the Department/Bureau to: (a) Evaluate whether the proposed information collection is necessary for the proper functions of the Department, including whether the information will have practical utility; (b) Evaluate the accuracy of our estimate of the time and cost burden for this proposed collection, including the validity of the methodology and assumptions used; (c) Evaluate ways to enhance the quality, utility, and clarity of the information to be collected; and (d) Minimize the reporting burden on those who are to respond, including the use of automated collection techniques or other forms of information technology.

Comments that you submit in response to this notice are a matter of public record. We will include, or summarize, each comment in our request to OMB to approve this ICR. Before including your address, phone number, email address, or other personal identifying information in your comment, you should be aware that your entire comment—including your personal identifying information—may be made publicly available at any time. While you may ask us in your comment to withhold your personal identifying information from public review, we cannot guarantee that we will be able to do so.

Sheleen Dumas,

Department PRA Clearance Officer, Office of the Under Secretary for Economic Affairs, Commerce Department.

[FR Doc. 2024–04999 Filed 3–7–24; 8:45 am]

BILLING CODE 3510–07–P

DEPARTMENT OF COMMERCE

International Trade Administration

[C–570–163]

Certain Glass Wine Bottles From the People's Republic of China: Postponement of Preliminary Determination in the Countervailing Duty Investigation

AGENCY: Enforcement and Compliance, International Trade Administration, Department of Commerce.

DATES: Applicable March 8, 2024.

FOR FURTHER INFORMATION CONTACT: Preston Cox, Scarlet Jaldin, or Theodora Mattei, AD/CVD Operations, Enforcement and Compliance, International Trade Administration, U.S. Department of Commerce, 1401

Constitution Avenue NW, Washington, DC 20230; telephone: (202) 482-5041, 202-482-4275, or (202) 482-4834, respectively.

SUPPLEMENTARY INFORMATION:

Background

On January 18, 2024, the U.S. Department of Commerce (Commerce) initiated a countervailing duty (CVD) investigation on imports of certain glass wine bottles (wine bottles) from the People's Republic of China.¹ Currently, the preliminary determination is due no later than March 25, 2024.²

Postponement of Preliminary Determination

Section 703(b)(1) of the Tariff Act of 1930, as amended (the Act), requires Commerce to issue the preliminary determination in a CVD investigation within 65 days after the date on which Commerce initiated the investigation. However, section 703(c)(1) of the Act permits Commerce to postpone the preliminary determination until no later than 130 days after the date on which Commerce initiated an investigation if: (A) the petitioner makes a timely request for a postponement; or (B) Commerce concludes that the parties concerned are cooperating, that the investigation is extraordinarily complicated, and that additional time is necessary to make a preliminary determination. Under 19 CFR 351.205(e), the petitioner must submit a request for postponement 25 days or more before the scheduled date of the preliminary determination and must state the reasons for the request. Commerce will grant the request unless it finds compelling reasons to deny the request.

On February 29, 2024, the U.S. Glass Producers Coalition (the petitioner) timely filed a request for Commerce to postpone the preliminary CVD determination.³ The petitioner requested postponement of the preliminary determination because Commerce needs additional time to collect and analyze questionnaire

¹ See *Certain Glass Wine Bottles from the People's Republic of China: Initiation of Countervailing Duty Investigation*, 89 FR 4905 (January 25, 2024).

² The deadline for the preliminary determination, 65 days after initiation, is March 23, 2024, which is a Saturday. Commerce's practice dictates that, when a deadline falls on a weekend or Federal holiday, the appropriate deadline is the next business day, in this case Monday, March 25, 2024. See *Notice of Clarification: Application of "Next Business Day" Rule for Administrative Determination Deadlines Pursuant to the Tariff Act of 1930, As Amended*, 70 FR 24533 (May 10, 2005) (*Next Business Day Rule*).

³ See Petitioner's Letter, "Request for Postponement of the Preliminary Determination," dated February 29, 2024.

responses from the Government of China and the mandatory respondents in this investigation, given the complexity of the issues presented and the number of subsidy programs under investigation, and to issue supplemental questionnaires.⁴

In accordance with 19 CFR 351.205(e), the petitioner has stated the reasons for requesting a postponement of the preliminary determination, and Commerce finds there are no compelling reasons to deny the request. Therefore, in accordance with section 703(c)(1)(A) of the Act, Commerce is postponing the deadline for the preliminary determination to no later than 130 days after the date on which this investigation was initiated, *i.e.*, May 28, 2024.⁵ Pursuant to section 705(a)(1) of the Act and 19 CFR 351.210(b)(1), the deadline for the final determination of this investigation will continue to be 75 days after the date of the preliminary determination.

Notification to Interested Parties

This notice is issued and published pursuant to section 703(c)(2) of the Act and 19 CFR 351.205(f)(1).

Dated: March 4, 2024.

Ryan Majerus,

Deputy Assistant Secretary for Policy and Negotiations, performing the non-exclusive functions and duties of the Assistant Secretary for Enforcement and Compliance.

[FR Doc. 2024-04979 Filed 3-7-24; 8:45 am]

BILLING CODE 3510-DS-P

DEPARTMENT OF COMMERCE

International Trade Administration

[A-570-028]

Hydrofluorocarbon Blends From the People's Republic of China: Final Results of Antidumping Duty Administrative Review; 2021-2022

AGENCY: Enforcement and Compliance, International Trade Administration, Department of Commerce.

SUMMARY: The U.S. Department of Commerce (Commerce) determines that the sole mandatory respondent, Zhejiang Sanmei Chemical Industry Co., Ltd. (Sanmei) sold hydrofluorocarbon blends (HFC blends) from the People's Republic of China (China) at less than normal value (NV) during the period of

⁴ *Id.*

⁵ Postponing the preliminary determination to 130 days after initiation would place the deadline on May 27, 2024, which is a Federal holiday. Therefore, the appropriate deadline is the next business day, in this case Tuesday, May 28, 2024. See *Next Business Day Rule*.

review (POR), August 31, 2021, through July 31, 2022.

DATES: Applicable March 8, 2024.

FOR FURTHER INFORMATION CONTACT: Jerry Xiao, AD/CVD Operations, Office II, Enforcement and Compliance, International Trade Administration, U.S. Department of Commerce, 1401 Constitution Avenue NW, Washington, DC 20230; telephone: (202) 482-2273.

SUPPLEMENTARY INFORMATION:

Background

On September 6, 2023, Commerce published in the **Federal Register** the *Preliminary Results*¹ of the 2021-2022 administrative review of the antidumping duty order on HFC blends from China² and invited interested parties to comment.³ Subsequent to the *Preliminary Results*, we received case briefs and rebuttal briefs from Sanmei and the American HFC Coalition (the petitioner).⁴ On December 6, 2023, in accordance with section 751(a)(3)(A) of the Tariff Act of 1930, as amended (the Act), Commerce extended the deadline for issuing these final results until March 1, 2024.⁵ For a complete description of the events that occurred since the *Preliminary Results*, see the Issues and Decision Memorandum.⁶

Scope of the Order

The products subject to the *Order* are HFC blends from China. A full description of the scope of the *Order* is contained in the Issues and Decision Memorandum.⁷

Analysis of Comments Received

All issues raised in briefs filed by parties in this administrative review are

¹ See *Hydrofluorocarbon Blends from the People's Republic of China: Preliminary Results of Antidumping Duty Administrative Review; 2021-2022*, 88 FR 60926 (September 6, 2023) (*Preliminary Results*), and accompanying Preliminary Decision Memorandum (PDM).

² See *Hydrofluorocarbon Blends from the People's Republic of China: Antidumping Duty Order*, 81 FR 55436 (August 19, 2016) (*Order*).

³ See *Preliminary Results*, 88 FR at 60926.

⁴ See Petitioner's Letter, "Case Brief of the HFC Coalition," dated October 20, 2023; and Sanmei's Letter, "Zhejiang Sanmei's Case Brief," dated October 20, 2023; see also Petitioner's Letter, "Rebuttal Brief on behalf of the American HFC Coalition," dated November 1, 2023; and Sanmei's Letter "Zhejiang Sanmei's Rebuttal Brief," dated November 1, 2023.

⁵ See Memorandum, "Extension of Deadline for Final Results of Antidumping Duty Administrative Review," dated December 6, 2023.

⁶ See Memorandum, "Decision Memorandum for the Final Results of the 2021-2022 Administrative Review of the Antidumping Duty Order on Hydrofluorocarbon Blends from the People's Republic of China," dated concurrently with, and hereby adopted by, this notice (Issues and Decision Memorandum).

⁷ *Id.*

addressed in the Issues and Decision Memorandum and are listed in Appendix I to this notice. The Issues and Decision Memorandum is a public document and on file electronically via Enforcement and Compliance's Antidumping and Countervailing Duty Centralized Electronic Service System (ACCESS). ACCESS is available to registered users at <https://access.trade.gov>. In addition, a complete version of the Issues and Decision Memorandum can be accessed directly at <https://access.trade.gov/public/FRNoticesListLayout.aspx>.

Separate Rate

Commerce preliminarily determines that one respondent, Sanmei, the only company individually examined in this review, is eligible to receive a separate rate in this review.⁸

China-Wide Entity

Under Commerce's policy regarding the conditional review of the China-wide entity,⁹ the China-wide entity will not be under review unless a party specifically requests, or Commerce self-initiates, a review of the entity. Because no party requested a review of the China-wide entity in this review, the entity is not under review, and the entity's rate (*i.e.*, 216.37 percent) is not subject to change.¹⁰ Commerce considers the 16 companies for which a review was requested (which did not file a separate rate application or did not demonstrate separate rate eligibility) listed in Appendix II to this notice, to be part of the China-wide entity.¹¹

Changes Since the Preliminary Results

Based on our review of the record and comments received from interested parties regarding our *Preliminary Results*, and for the reasons explained in the Issues and Decision Memorandum, we made certain changes to the margin calculations for Sanmei.¹²

⁸ See *Preliminary Results* at "Separate Rates" section.

⁹ See *Antidumping Proceedings: Announcement of Change in Department Practice for Respondent Selection in Antidumping Duty Proceedings and Conditional Review of the Nonmarket Economy Entity in NME Antidumping Duty Proceedings*, 78 FR 65963 (November 4, 2013).

¹⁰ See *Order*.

¹¹ See *Initiation Notice*, 87 FR at 61285, (stating "[a]ll firms listed below that wish to qualify for separate rate status in the administrative reviews involving NME countries must complete, as appropriate, either a separate rate application or certification, as described below."); see also Appendix II, *infra*, for the list of companies that are subject to this administrative review that are considered to be part of the China-wide entity.

¹² See Issues and Decision Memorandum.

Final Results of Review

For the company subject to this review that established its eligibility for a separate rate, Commerce determines that the following estimated weighted-average dumping margin exists for the period August 31, 2021, through July 31, 2022:

Exporter	Weighted-average dumping margin (percent)
Zhejiang Sanmei Chemical Industry Co., Ltd	101.14

Disclosure

Commerce intends to disclose the calculations performed in connection with these final results of review to interested parties within five days after public announcement of the final results or, if there is no public announcement, within five days of the date of publication of the notice of final results in the **Federal Register**, in accordance with 19 CFR 351.224(b).

Assessment Rates

Pursuant to section 751(a)(2)(A) of the Act, and 19 CFR 351.212(b)(1), Commerce shall determine, and U.S. Customs and Border Protection (CBP) shall assess, antidumping duties on all appropriate entries of subject merchandise in accordance with the final results of this review.

For Sanmei, Commerce will calculate importer-specific assessment rates for antidumping duties, in accordance with 19 CFR 351.212(b)(1). Where the respondent reported reliable entered values, Commerce intends to calculate importer-specific *ad valorem* assessment rates by aggregating the amount of dumping calculated for all U.S. sales to the importer and dividing this amount by the total entered value of the merchandise sold to the importer. Where the respondent did not report entered values, Commerce will calculate importer-specific assessment rates by dividing the amount of dumping for reviewed sales to the importer by the total quantity of those sales. Commerce will calculate an estimated *ad valorem* importer-specific assessment rate to determine whether the per-unit assessment rate is *de minimis*; however, Commerce will use the per-unit assessment rate where entered values were not reported. Where an importer-specific *ad valorem* assessment rate is not zero or *de minimis*, Commerce will instruct CBP to collect the appropriate duties at the time of liquidation. Where either the respondent's weighted

average dumping margin is zero or *de minimis*, or an importer-specific *ad valorem* assessment rate is zero or *de minimis*, Commerce will instruct CBP to liquidate appropriate entries without regard to antidumping duties.¹³

For entries that were not reported in the U.S. sales database submitted by the exporter individually examined during this review, Commerce will instruct CBP to liquidate such entries at the China-wide rate.¹⁴

Commerce determined that the companies listed in Appendix II did not qualify for a separate rate. Therefore, we will instruct CBP to assess antidumping duties on entries of subject merchandise from these entities at 216.37 percent, the established weighted-average dumping margin for the China-wide entity.

Commerce intends to issue assessment instructions to CBP no earlier than 35 days after the date of publication of the final results of this review in the **Federal Register**. If a timely summons is filed at the U.S. Court of International Trade, the assessment instructions will direct CBP not to liquidate relevant entries until the time for parties to file a request for a statutory injunction has expired (*i.e.*, within 90 days of publication).

Cash Deposit Requirements

The following cash deposit requirements will be effective upon publication of the final results of this administrative review for shipments of the subject merchandise from China entered, or withdrawn from warehouse, for consumption on or after the publication date, as provided by section 751(a)(2)(C) of the Act: (1) for the exporter listed above, the cash deposit rate will be equal to the weighted-average dumping margin established in the final results of this review; (2) for previously investigated or reviewed Chinese and non-Chinese exporters not listed above that currently have a separate rate, the cash deposit rate will continue to be the exporter-specific rate published for the most recently completed segment of this proceeding where the exporter received that separate rate; (3) for all Chinese exporters of subject merchandise that have not been found to be entitled to a separate rate, the cash deposit rate will be the rate for the China-wide entity (*i.e.*, 216.37 percent); and (4) for all non-Chinese exporters of subject merchandise that have not received their own separate rate, the cash deposit

¹³ See 19 CFR 351.106(c)(2).

¹⁴ For a full discussion of this practice, see *Non-Market Economy Antidumping Proceedings: Assessment of Antidumping Duties*, 76 FR 65694 (October 24, 2011).

rate will be the rate applicable to the Chinese exporter that supplied that non-Chinese exporter. These deposit requirements, when imposed, shall remain in effect until further notice.

Notification to Importers

This notice serves as a final reminder to importers of their responsibility under 19 CFR 351.402(f)(2) to file a certificate regarding the reimbursement of antidumping duties prior to liquidation of the relevant entries during this POR. Failure to comply with this requirement could result in Commerce's presumption that reimbursement of antidumping duties has occurred and the subsequent assessment of double antidumping duties.

Administrative Protective Order

This notice also serves as a final reminder to parties subject to an administrative protective order (APO) of their responsibility concerning the return or destruction of proprietary information disclosed under APO in accordance with 19 CFR 351.305(a)(3), which continues to govern business proprietary information in this segment of the proceeding. Timely written notification of the return or destruction of APO materials or conversion to judicial protective order is hereby requested. Failure to comply with the regulations and terms of an APO is a violation subject to sanction.

Notification to Interested Parties

We are issuing and publishing these final results of administrative review in accordance with sections 751(a)(1) and 777(i)(1) of the Act and 19 CFR 351.221(b)(5) and 19 CFR 351.213(h)(2).

Dated: March 1, 2024.

Ryan Majerus,

Deputy Assistant Secretary for Policy and Negotiations, performing the non-exclusive functions and duties of the Assistant Secretary for Enforcement and Compliance.

Appendix I

List of Topics Discussed in the Issues and Decision Memorandum

- I. Summary
- II. Background
- III. Scope of the Order
- IV. Changes Since the Preliminary Results
- V. Discussion of the Issues
 - Comment 1: Selection of Surrogate Country
 - Comment 2: Selection of Surrogate Financial Statements
 - Comment 3: Trichloroethylene (TCE) Surrogate Value
 - Comment 4: Certain Errors in Preliminary Margin Calculation
 - Comment 5: By-Product Offsets
- VI. Recommendation

Appendix II

Companies Considered To Be Part of the China-Wide Entity

1. Changzhou Vista Chemical Co., Ltd.
2. Daikin Fluorochemicals (China) Co., Ltd.
3. Dongyang Weihua Refrigerants Co., Ltd.
4. Hangzhou Icetop Refrigeration Co., Ltd.
5. Jiangsu Sanmei Chemicals Co., Ltd.
6. Oasis Chemical Co., Limited
7. Sinochem Environmental Protection Chemicals (Taicang) Co., Ltd.
8. Superfy Industrial Limited
9. Tianjin Synergy Gases Products, Co., Ltd.
10. Weitron International Refrigeration Equipment (Kunshan) Co., Ltd.
11. Weitron International Refrigeration Equipment Co., Ltd.
12. Yangfar Industry Co., Ltd
13. Zhejiang Lantian Environmental Protection Fluoro Material Co. Ltd
14. Zhejiang Quzhou Lianzhou Refrigerants Co., Ltd
15. Zhejiang Yonghe Refrigerant Co., Ltd
16. Zhejiang Zhonglan Refrigeration Technology Co., Ltd

[FR Doc. 2024-04977 Filed 3-7-24; 8:45 am]

BILLING CODE 3510-DS-P

DEPARTMENT OF COMMERCE

International Trade Administration

[A-570-117]

Wood Mouldings and Millwork Products From the People's Republic of China: Preliminary Results Intent To Rescind, in Part, and Rescission in Part, of Antidumping Duty Administrative Review; 2022-2023

AGENCY: Enforcement and Compliance, International Trade Administration, Department of Commerce.

SUMMARY: The U.S. Department of Commerce (Commerce) preliminarily determines that Fujian Jinquan Trade Co., Ltd./Baiyuan Wood Machining Co., Ltd. (Jinquan/Baiyuan) and 22 non-individually examined and separate-rate eligible exporters of wood mouldings and millwork products (millwork products) from the People's Republic of China (China) sold subject merchandise to the United States at prices below normal value (NV) during the period of review (POR), February 1, 2022, through January 31, 2023. Commerce also preliminarily determines that Fujian Yinfeng Imp & Exp Trading Co., Ltd./Fujian Province Youxi City Mangrove Wood Machining Co., Ltd. (Yinfeng/Mangrove) did not sell subject merchandise to the United States at prices below NV during the POR. We intend to rescind this review with respect to 12 companies for which the U.S. Customs and Border Protection (CBP) data show no entries of the subject merchandise from these

companies during the POR.

Additionally, we are rescinding this administrative review with respect to seven companies because the requests for review for these companies were timely withdrawn. Finally, we preliminarily find that four companies are part of the China-wide entity. We invited interested parties to comment on these preliminary results.

DATES: Applicable March 8, 2024.

FOR FURTHER INFORMATION CONTACT:

Brian Smith or Robert Palmer, AD/CVD Operations, Office VIII, Enforcement and Compliance, International Trade Administration, Department of Commerce, 1401 Constitution Avenue NW, Washington, DC 20230; telephone: (202) 482-1766 and (202) 482-9068, respectively.

SUPPLEMENTARY INFORMATION:

Background

This administrative review is being conducted in accordance with section 751(a) of the Tariff Act of 1930, as amended (the Act). The review covers 47 companies, including mandatory respondents, Jinquan/Baiyuan and Yinfeng/Mangrove.¹ For a complete description of the events that followed the initiation of this administrative review, see the Preliminary Decision Memorandum. A list of topics discussed in the Preliminary Decision Memorandum is included as Appendix I to this notice. The Preliminary Decision Memorandum is a public document and is on file electronically via Enforcement and Compliance's Antidumping and Countervailing Duty Centralized Electronic Service System (ACCESS). ACCESS is available to registered users at <https://access.trade.gov>. In addition, a complete version of the Preliminary Decision Memorandum can be accessed directly at <https://access.trade.gov/public/FRNoticesListLayout.aspx>.

Scope of the Order²

The merchandise covered by the Order is wood mouldings and millwork

¹ We have determined that it is appropriate to continue to treat affiliates Yinfeng and Mangrove as a single entity, and affiliates Jinquan and Baiyuan, as a single entity for purposes of this administrative review, consistent with past segments of this proceeding. For further discussion, see Memorandum, "Decision Memorandum of the Preliminary Results of Antidumping Duty Administrative Review; 2022-2023: Wood Mouldings and Millwork Products from the People's Republic of China," dated concurrently with, and hereby adopted by, this notice (Preliminary Decision Memorandum).

² See *Wood Mouldings and Millwork Products from the People's Republic of China: Amended Final Antidumping Duty Determination and Antidumping Duty Order*, 86 FR 9486 (February 16, 2021) (Order).

products from China. For a complete description of the scope of the *Order*, see the Preliminary Decision Memorandum.

Methodology

Commerce is conducting this review in accordance with section 751(a)(1)(B) of the Act and 19 CFR 351.213. We calculated export prices in accordance with section 772 of the Act. Because China is a non-market economy (NME) country within the meaning of section 771(18) of the Act, NV has been calculated in accordance with section 773(c) of the Act. For a full description of the methodology underlying our preliminary conclusions, see the Preliminary Decision Memorandum.

Intent To Rescind Administrative Review, in Part

Pursuant to 19 CFR 351.213(d)(3), it is Commerce's practice to rescind an administrative review of an antidumping duty order where it determines that there were no suspended entries of subject merchandise during the POR.³ Normally, upon completion of an administrative review, the suspended entries are liquidated at the antidumping duty assessment rate for the review period.⁴ Therefore, for an administrative review to be conducted, there must be a reviewable, suspended entry that Commerce can instruct CBP to liquidate at the calculated antidumping duty assessment rate for the review period.⁵

On May 31, 2023, Commerce placed CBP entry data on the record for U.S. imports of the subject merchandise during the POR for respondent selection

purposes.⁶ Twelve companies under review have existing separate rates but no suspended entries during the POR.⁷ In the absence of any reviewable, suspended entries of subject merchandise from these companies during the POR, Commerce hereby notifies all interested parties of its intent to rescind this administrative review with respect to these companies. Commerce is providing interested parties with an opportunity to submit comments on this preliminary decision, including factual information. Comments, including factual information, from interested parties are due to Commerce no later than seven days after the publication of these preliminary results. Rebuttal comments, including rebuttal factual information, are due seven days thereafter. All submissions must be filed electronically at <http://access.trade.gov> in accordance with 19 CFR 351.303.

Rescission of Administrative Review, in Part

Pursuant to 19 CFR 351.213(d)(1), Commerce will rescind an administrative review, in whole or in part, if a party who requested the review withdraws the request within 90 days of the date of publication of the notice of initiation of the requested review. On May 8, 2023, Xuzhou Goodwill Resource Co., Ltd. (Xuzhou Goodwill) and Sanming Lintong Trading Co., Ltd. (Sanming Lintong) each timely withdrew its request for review of itself.⁸ On July 7, 2023, Jeld-Wen, Inc. (Jeld-Wen), a U.S. importer of the subject merchandise, timely withdrew its request for review of Zhejiang Senya Board Industry Co., Ltd. (Zhejiang Senya).⁹ Finally, on July 10, 2023, the petitioner timely withdrew its requests for review of four companies (*i.e.*, Fujian Shunchang Shengsheng Wood Industry Limited Company (Shunchang Shengsheng), TL Wood Products, Inc. (TL Wood), Xiamen Jinxi Building Material Co., Ltd. (Xiamen Jinxi), and Zhangzhou Green Wood Industry and Trade Co., Ltd. (Zhangzhou Green Wood)),¹⁰ one of which, Shunchang Shengsheng, also withdrew its review

request on July 10, 2023.¹¹ Because no other parties requested a review of the above seven companies, Commerce is rescinding the administrative review with respect to these companies.

Separate Rates

Commerce preliminarily finds that, in addition to Yinfeng/Mangrove and Jinquan/Baiyuan, the information placed on the record by 22 companies not individually examined in this review demonstrates that these companies are eligible for a separate rate.¹²

The statute and Commerce's regulations do not address what dumping margin to apply to respondents not selected for individual examination when Commerce limits its examination in an administrative review pursuant to section 777A(c)(2) of the Act. Generally, Commerce looks to section 735(c)(5) of the Act, which provides instructions for calculating the all-others rate in an investigation, for guidance when calculating the dumping margin for respondents that are not selected for individual examination in an administrative review. Section 735(c)(5)(A) of the Act states that the all-others rate should be calculated by averaging the weighted-average dumping margins calculated for individually-examined respondents, excluding dumping margins that are zero, *de minimis*, or based entirely on facts available. Because we calculated a preliminary dumping margin of zero for Yinfeng/Mangrove, and a preliminary dumping margin that is not zero, *de minimis*, or based entirely on facts available for Jinquan/Baiyuan, we assigned the separate-rate recipients a preliminary dumping margin equal to Jinquan/Baiyuan's preliminary dumping margin consistent with Commerce's practice and section 735(c)(5)(A) of the Act.

The China-Wide Entity

Commerce's policy regarding conditional review of the China-wide entity applies to this administrative review.¹³ Under this policy, the China-wide entity will not be under review unless a party specifically requests and Commerce initiates, or Commerce self-initiates, a review of the China-wide

³ See, e.g., *Certain Carbon and Alloy Steel Cut-to Length Plate from the Federal Republic of Germany: Rescission of Antidumping Administrative Review*, 2020–2021, 88 FR 4157 (January 24, 2023).

⁴ See 19 CFR 351.212(b)(1).

⁵ See, e.g., *Shanghai Sunbeauty Trading Co. v. United States*, 380 F. Supp. 3d 1328, 1335–36 (CIT 2019), at 12 (referring to section 751(a) of the Act, the U.S. Court of International Trade held that: "While the statute does not explicitly require that an entry be suspended as a prerequisite for establishing entitlement to a review, it does explicitly state the determined rate will be used as the liquidation rate for the reviewed entries. This result can only obtain if the liquidation of entries has been suspended . . ." see also *Certain Frozen Fish Fillets from the Socialist Republic of Vietnam: Final Results of Antidumping Duty Administrative Review and Final Determination of No Shipments; 2018–2019*, 86 FR 36102, and accompanying Issues and Decision Memorandum at Comment 4; and *Solid Fertilizer Grade Ammonium Nitrate from the Russian Federation: Notice of Rescission of Antidumping Duty Administrative Review*, 77 FR 65532 (October 29, 2012) (noting that "for an administrative review to be conducted, there must be a reviewable, suspended entry to be liquidated at the newly calculated assessment rate").

⁶ See Memorandum, "Release of U.S. Customs and Border Protection Data," dated May 31, 2023.

⁷ See Appendix IV for a list of these companies.

⁸ See Sanming Lintong's Letter, "Withdrawal of Request for Review," dated May 8, 2023; see also Xuzhou Goodwill's Letter, "Withdrawal of Request for Review," dated May 8, 2023.

⁹ See Jeld-Wen's Letter, "Withdrawal of Request for Administrative Review," dated July 7, 2023; see also Jeld-Wen's Letter, "Request of administrative Review," dated February 28, 2023.

¹⁰ See Petitioner's Letter, "Partial Withdrawal of Request for Administrative Review," dated July 10, 2023.

¹¹ See Shunchang Shengcheng's Letter, "Withdrawal of Request for Administrative Review," dated July 10, 2023.

¹² See Appendix II for a list of these companies.

¹³ See *Antidumping Proceedings: Announcement of Change in Department Practice for Respondent Selection in Antidumping Proceedings and Conditional Review of the Nonmarket Economy Entity in NME Antidumping Duty Proceedings*, 78 FR 65963 (November 4, 2013).

entity.¹⁴ Because no party requested a review of the China-wide entity and no review was initiated for this POR, the China-wide entity is not under review and the China-wide entity's rate (*i.e.*, 220.87 percent) is not subject to change.¹⁵ Commerce preliminarily finds

that four companies¹⁶ did not establish their eligibility for a separate rate because they failed to provide a separate rate application or a separate rate certification. As such, we preliminarily determine that these companies are part of the China-wide entity.

Preliminary Results of Review

Commerce preliminarily determines that the following estimated weighted-average dumping margins exist for the POR:

Exporter	Weighted-average dumping margin (percent)
Fujian Jinquan Trade Co., Ltd./Baiyuan Wood Machining Co., Ltd	4.72
Fujian Yinfeng Imp & Exp Trading Co., Ltd./Fujian Province Youxi City Mangrove Wood Machining Co., Ltd	0.00
Non-Selected Companies Under Review Receiving a Separate Rate ¹⁷	4.72

Disclosure and Public Comment

Commerce intends to disclose its calculations and analysis performed to interested parties for these preliminary results within five days of any public announcement or, if there is no public announcement, within five days of the date of publication of this notice in accordance with 19 CFR 351.224(b).

Pursuant to 19 CFR 351.309(c), interested parties may submit case briefs to Commerce no later than 30 days after the date of publication of this notice. Rebuttal briefs, limited to issues raised in the case briefs, may be filed not later than five days after the date for filing case briefs.¹⁸ Interested parties who submit case briefs or rebuttal briefs in this proceeding must submit: (1) a table of contents listing each issue; and (2) a table of authorities.¹⁹

As provided under 19 CFR 351.309(c)(2) and (d)(2), in prior proceedings we have encouraged interested parties to provide an executive summary of their briefs that should be limited to five pages total, including footnotes. In this review, we instead request that interested parties provide at the beginning of their briefs a public, executive summary for each issue raised in their briefs.²⁰ Further, we request that interested parties limit their executive summary of each issue to no more than 450 words, not including citations. We intend to use the executive summaries as the basis of the comment summaries included in the issues and decision memorandum that will accompany the final results in this administrative review. We request that interested parties include footnotes for

relevant citations in the executive summary of each issue. Note that Commerce has amended certain of its requirements pertaining to the service of documents in 19 CFR 351.303(f).²¹

Pursuant to 19 CFR 351.310(c), interested parties who wish to request a hearing must submit a written request to the Assistant Secretary for Enforcement and Compliance, filed electronically via Enforcement and Compliance's Antidumping and CVD Centralized Electronic Service System (ACCESS). Requests should contain: (1) the party's name, address, and telephone number; (2) the number of participants; and (3) a list of issues to be discussed. Issues raised in the hearing will be limited to those raised in the respective case briefs. An electronically filed hearing request must be received successfully in its entirety by Commerce's electronic records system, ACCESS, by 5:00 p.m. Eastern Time within 30 days after the date of publication of this notice.

Commerce intends to issue the final results of this administrative review, which will include the results of its analysis of issues raised in any briefs, within 120 days of the date of publication of these preliminary results, pursuant to section 751(a)(3)(A) of the Act and 19 CFR 351.213(h), unless this deadline is extended.

Assessment Rates

In accordance with section 751(a)(2)(C) of the Act, the final results of this review shall be the basis for the assessment of antidumping duties on entries of merchandise covered by this review. Upon issuance of the final results, Commerce will determine, and

CBP shall assess, antidumping duties on all appropriate entries covered by this review.²²

For the companies for which we are not rescinding this administrative review, Commerce intends to issue assessment instructions to CBP no earlier than 35 days after the date of publication of the final results of this review. If a timely summons is filed at the U.S. Court of International Trade, the assessment instructions will direct CBP not to liquidate relevant entries until the time for parties to file a request for a statutory injunction has expired (*i.e.*, within 90 days of publication).

If a mandatory respondent's *ad valorem* weighted-average dumping margin is not zero or *de minimis* (*i.e.*, less than 0.50 percent) in the final results of this review, Commerce will calculate importer-specific assessment rates for that respondent, in accordance with 19 CFR 351.212(b)(1).²³

For sales for which the respondents reported entered value, Commerce intends to calculate importer-specific *ad valorem* assessment rates based on the ratio of the total amount of dumping calculated for each importer's examined sales to the total entered value of those sales, in accordance with 19 CFR 351.212(b)(1). For sales for which the respondents did not report entered value, we will calculate importer-specific per-unit duty assessment rates based on the ratio of the total amount of antidumping duties calculated for the examined sales to the total quantity of those sales. To determine whether an importer-specific, per-unit assessment rate is *de minimis*, in accordance with 19 CFR 351.106(c)(2), we also will

¹⁴ *Id.*

¹⁵ See Order, 86 FR at 9488.

¹⁶ These companies are: (1) Aventura, Inc. (Aventura); (2) China Cornici, Co. Ltd. (China Cornici); (3) Gaomi Hongtai Home Furniture Co., Ltd. (Gaomi Hongtai); and (4) and Shuyang Zhongding Decoration Materials Co., Ltd. (Shuyang Zhongding).

¹⁷ See Appendix II.

¹⁸ See 19 CFR 351.309(d); see also *Administrative Protective Order, Service, and Other Procedures in Antidumping and Countervailing Duty Proceedings*, 88 FR 67069, 67077 (September 29, 2023) (*APO and Service Final Rule*).

¹⁹ See 19 CFR 351.309(c)(2) and (d)(2).

²⁰ We use the term "issue" here to describe an argument that Commerce would normally address in a comment of the Issues and Decision Memorandum.

²¹ See *APO and Service Final Rule*.

²² See 19 CFR 351.212(b)(1).

²³ In these preliminary results, Commerce applied the assessment rate calculation method adopted in *Antidumping Proceedings: Calculation of the Weighted-Average Dumping Margin and Assessment Rate in Certain Antidumping Proceedings: Final Modification*, 77 FR 8101 (February 14, 2012).

calculate an importer-specific *ad valorem* ratio based on estimated entered values.

If, in the final results, a mandatory respondent's weighted-average dumping margin is zero or *de minimis* (*i.e.*, less than 0.5 percent), Commerce will instruct CBP to liquidate the appropriate entries for that respondent without regard to antidumping duties.²⁴ For entries that were not reported in the U.S. sales databases submitted by each mandatory respondent during this review, and for the companies that do not qualify for a separate rate, Commerce will instruct CBP to liquidate such entries at the China-wide rate (*i.e.*, 220.87 percent).²⁵ For the respondents that were not selected for individual examination in this administrative review but qualified for a separate rate, the assessment rate will be equal to the weighted-average dumping margin determined in the final results of this review.

For the companies for which we are rescinding this review based on the timely withdrawal of all review requests, we intend to instruct CBP to assess antidumping duties on all appropriate entries at a rate equal to the cash deposit rate of estimated antidumping duties required at the time of entry, or withdrawal from warehouse, for consumption in accordance with 19 CFR 351.212(c)(1)(i). Commerce intends to issue assessment instructions to CBP for the rescinded companies no earlier than 35 days after the date of publication of this notice in the **Federal Register**.

For the companies for which we intend to rescind the review in the final results based on no reviewable entries, provided we receive no contrary information, we intend to instruct CBP to assess antidumping duties on all appropriate entries at a rate equal to the cash deposit rate of estimated antidumping duties required at the time of entry, or withdrawal from warehouse, for consumption in accordance with 19 CFR 351.212(c)(1)(i). Commerce intends to issue assessment instructions to CBP for these companies no earlier than 35 days after the date of publication of the final results in the **Federal Register**.

Cash Deposit Requirements

The following cash deposit requirements will be effective upon publication of the final results of this administrative review for shipments of the subject merchandise from China entered, or withdrawn from warehouse, for consumption on or after the

publication date, as provided by section 751(a)(2)(C) of the Act: (1) for companies listed above that have established their eligibility for a separate rate, the cash deposit rate will be equal to the weighted-average dumping margin established in the final results of this review (except, if the rate is *de minimis*, then the cash deposit rate will be zero); (2) for previously examined Chinese and non-Chinese exporters not listed above that received a separate rate in a prior completed segment of this proceeding, the cash deposit rate will continue to be the existing exporter-specific cash deposit rate; (3) for all Chinese exporters of subject merchandise that have not been found to be entitled to a separate rate, the cash deposit rate will be the rate for the China-wide entity (*i.e.*, 220.87 percent); and (4) for all non-Chinese exporters of subject merchandise which have not received their own separate rate, the cash deposit rate will be the rate applicable to the Chinese exporter that supplied that non-Chinese exporter. These cash deposit requirements, when imposed, shall remain in effect until further notice.

Notification to Importers

This notice also serves as a preliminary reminder to importers of their responsibility under 19 CFR 351.402(f)(2) to file a certificate regarding the reimbursement of antidumping and/or countervailing duties prior to liquidation of the relevant entries during this POR. Failure to comply with this requirement could result in Commerce's presumption that reimbursement of antidumping and/or countervailing duties occurred and the subsequent assessment of double antidumping duties, and/or an increase in the amount of antidumping duties by the amount of the countervailing duties.

Notification to Interested Parties

This administrative review and notice are issued and published in accordance with sections 751(a)(1) and 777(i)(1) of the Act, 19 CFR 351.213(d)(4), and 19 CFR 351.221(b)(4).

Dated: February 28, 2024.

Ryan Majerus

Deputy Assistant Secretary for Policy and Negotiations, performing the non-exclusive functions and duties of the Assistant Secretary for Enforcement and Compliance.

Appendix I

List of Topics Discussed in the Preliminary Decision Memorandum

- I. Summary
- II. Background
- III. Scope of the Order
- IV. Rescission of Review, in Part

- V. Intent to Rescind Review, in Part
- VI. Discussion of the Methodology
- VII. Recommendation

Appendix II

Non-Selected Companies Under Review Receiving a Separate Rate

1. Anji Huaxin Bamboo & Wood Products Co., Ltd.
2. Composite Technology International, Limited
3. Fujian Hongjia Craft Products Co., Ltd.
4. Fujian Sanming City Donglai Wood Co., Ltd.
5. Fujian Wangbin Decorative Material Co., Ltd.
6. Fujian Youxi Best Arts & Crafts Co. Ltd.
7. Huaan Longda Wood Industry Co., Ltd.
8. Jiangsu Wenfeng Wood Co., Ltd.
9. Longquan Jiefeng Trade Co., Ltd.
10. Nanping Huatai Wood & Bamboo Co., Ltd.
11. Nicer Window Fashions Co., Ltd.
12. Putian Yihong Wood Industry Co., Ltd.
13. Qimen Jianxing Bamboo and Wood Goods Co., Ltd.
14. Rui Xing Wooden Products Co., Ltd.
15. Shandong Miting Household Co., Ltd.
16. Shaxian Hengtong Wood Industry Co., Ltd.
17. Shaxian Shiyiwood, Ltd.
18. Shuyang Kevin International Co., Ltd.
19. Sun Valley Shade Co., Ltd.
20. Suqian Sulu Import & Export Trading Co., Ltd.
21. Zhangzhou Wangjiamai Industry & Trade Co., Ltd.
22. Zhangzhou Yihong Industrial Co., Ltd.

Appendix III

Companies for Which the Review Is Rescinded

1. Fujian Shunchang Shengsheng Wood Industry Limited Company
2. Sanming Lintong Trading Co., Ltd.
3. TL Wood Products, Inc.
4. Xiamen Jinxi Building Material Co., Ltd.
5. Xuzhou Goodwill Resource Co., Ltd.
6. Zhangzhou Green Wood Industry and Trade Co., Ltd.
7. Zhejiang Senya Board Industry Co., Ltd.

Appendix IV

Companies Which Have No Reviewable Entries

1. Jiangsu Chen Sheng Forestry Development Co., Ltd.
2. Omni One Co., Ltd.
3. Raoping HongRong Handicrafts Co., Ltd.
4. Baixing Import and Export Trading Co., Ltd. Youxi Fujian
5. Bel Trade Wood Industrial Co., Ltd. Youxi Fujian
6. Fotiou Frames Limited
7. Fujian Zhangping Kimura Forestry Products Co., Ltd.
8. Homebuild Industries Co., Ltd.
9. Jim Fine Wooden Products Co., Ltd.
10. Shenzhen Xinjintai Industrial Co., Ltd.
11. Tim Feng Manufacturing Co., Ltd.
12. Wuxi Boda Bamboo & Wood Industrial Co., Ltd.

[FR Doc. 2024-04980 Filed 3-7-24; 8:45 am]

BILLING CODE 3510-DS-P

²⁴ See 19 CFR 351.106(c)(2).

²⁵ See Order.

DEPARTMENT OF COMMERCE**National Oceanic and Atmospheric Administration**

[RTID 0648–XD780]

Gulf of Mexico Fishery Management Council; Public Meeting

AGENCY: National Marine Fisheries Service (NMFS), National Oceanic and Atmospheric Administration (NOAA), Commerce.

ACTION: Notice of a closed meeting.

SUMMARY: The Gulf of Mexico Fishery Management Council will hold a CLOSED SESSION webinar of its Law Enforcement Technical Committee (LETC).

DATES: The webinar will convene on Monday, March 25, 2024, from 11 a.m. to 12 p.m., EDT (10 a.m.–11 p.m. CDT).

ADDRESSES: The meeting will be a CLOSED SESSION webinar only.

Council address: Gulf of Mexico Fishery Management Council, 4107 W Spruce Street, Suite 200, Tampa, FL 33607; telephone: (813) 348–1630.

FOR FURTHER INFORMATION CONTACT: Dr. Assane Diagne, Economist, Gulf of Mexico Fishery Management Council; *assane.diagne@gulfcouncil.org*; telephone: (813) 348–1630.

SUPPLEMENTARY INFORMATION: The following items of discussion are on the agenda, though agenda items may be addressed out of order and any changes will be noted on the Council's website when possible.

Monday, March 25, 2024; 11 a.m.–12 p.m., EDT

The webinar meeting will be in a CLOSED SESSION from 11 a.m. to 12 p.m. EDT with introductions and review of nominations for the 2023 Office/Team of the Year Award.

—Meeting Adjourns

The Agenda is subject to change, and the latest version along with other meeting materials will be posted on *www.gulfcouncil.org*.

The LETC consists of principal law enforcement officers in each of the Gulf States, as well as the NOAA Office of Law Enforcement, U.S. Fish and Wildlife Service, the U.S. Coast Guard, and the NOAA Office of General Counsel for Law Enforcement.

Although other non-emergency issues not on the agenda may come before this group for discussion, in accordance with the Magnuson-Stevens Fishery Conservation and Management Act, those issues may not be the subject of formal action during this meeting. Actions will be restricted to those issues

specifically identified in the agenda and any issues arising after publication of this notice that require emergency action under Section 305(c) of the Magnuson-Stevens Fishery Conservation and Management Act, provided the public has been notified of the Council's intent to take action to address the emergency.

Authority: 16 U.S.C. 1801 *et seq.*

Dated: March 4, 2024.

Rey Israel Marquez,

Acting Deputy Director, Office of Sustainable Fisheries, National Marine Fisheries Service.

[FR Doc. 2024–04924 Filed 3–7–24; 8:45 am]

BILLING CODE 3510–22–P

DEPARTMENT OF COMMERCE**National Oceanic and Atmospheric Administration****Request for Information: Private Remote Sensing Satellite Disposal and Debris Mitigation**

AGENCY: National Oceanic and Atmospheric Administration (NOAA), Department of Commerce.

ACTION: Request for information.

SUMMARY: The Commercial Remote Sensing Regulatory Affairs (CRSRA) division of the National Oceanic and Atmospheric Administration's (NOAA's) Office of Space Commerce seeks information from interested parties regarding the condition in every CRSRA license requiring the disposal of on orbit spacecraft in a manner satisfactory to the President. This input is necessary to inform CRSRA's approach to providing additional guidance or initiating a narrow rulemaking pertaining to its disposal condition.

DATES: Submit written comments on or before April 8, 2024.

ADDRESSES: The public may submit written comments on issues addressed in this Notice by either of the following methods:

- *Electronic Submission:* Submit all electronic public comments via email to *space.commerce@noaa.gov*.

- *Mail:* Submit written comments to Office of Space Commerce, Herbert C. Hoover Building, Room 68015, 1401 Constitution Ave. NW, Washington, DC 20230.

Instructions: Comments must be submitted by one of the above methods to ensure that the comments are received, documented, and considered by the Department. Comments sent by any other method, to any other address or individual, or received after the end of the comment period, may not be

considered. All comments received are a part of the public record and will generally be posted for public viewing on *www.space.commerce.gov* without change. All personal identifying information (*e.g.*, name, address) submitted voluntarily by the sender will be publicly accessible. Do not submit confidential business information, or otherwise sensitive or protected information. The Department will accept anonymous comments (enter “N/A” in the relevant fields if you wish to remain anonymous).

FOR FURTHER INFORMATION CONTACT:

Sarah Brothers, Commercial Remote Sensing Regulatory Affairs, 1401 Constitution Ave. NW, Room 31027, Washington, DC 20230, *sarah.brothers@noaa.gov*, (771) 216–4112.

SUPPLEMENTARY INFORMATION:**I. Background***A. Authority for the Supervision of System Disposal*

The National Oceanic and Atmospheric Administration (NOAA), Office of Space Commerce (OSC), Commercial Remote Sensing Regulatory Affairs (CRSRA) division, issues licenses for the operation of private space-based remote sensing systems under the jurisdiction of the United States and monitors compliance of licensees to the terms of their license(s), the regulation, and law. CRSRA's authorizing statute, 51 U.S.C. chapter 601 (the Land Remote Sensing Policy Act of 1992), includes a requirement to include in any remote sensing license issued a condition specifying that the licensee shall, upon termination of operations under the license, make disposition of any satellites in space in a manner satisfactory to the President (hereinafter the “subsection (b)(4) license requirement”).

The subsection (b)(4) license requirement includes both the responsible disposal of on-orbit systems at end of life and the mitigation of orbital debris and survivability of such upon reentry. From 2000 to 2020, CRSRA required all applicants for remote sensing licenses to submit to CRSRA a disposal and orbital debris mitigation plan and supervised this element of system operations. CRSRA required these plans to assess and minimize the amount of orbital debris released during post-mission disposal of licensed satellites. CRSRA assessed the submitted plans and determined whether they provided an acceptable post-mission disposal method to mitigate orbital debris and minimize any potential adverse effects.

CRSRA ceased requiring such plans after updating its regulations in 2020. This decision was based upon the observation at the time the regulations were promulgated that nearly all Commerce-licensed systems were also licensed by the Federal Communications Commission (FCC), and FCC licenses already address orbital debris and disposal issues in a comprehensive manner. To avoid duplicative regulation, Commerce opted to defer to FCC license requirements regarding orbital debris and spacecraft disposal, and therefore removed license conditions requiring specific orbital debris or spacecraft disposal practices in final rule. Rather, licenses would simply contain the text required by the Act: That “upon termination of operations under the license, [the licensee shall] make disposition of any satellites in space in a manner satisfactory to the President.” Commerce clarified that until further updates, the disposition manner satisfactory to the President was to follow the relevant FCC license.

At the time, however, Commerce noted that Commerce may issue guidance or undertake a separate, narrow rulemaking to revise the subsection (b)(4) license requirement and clarify the practices required by that condition in response to future needs.

Since the promulgation of the 2020 regulations, CRSRA has observed an increasing number of multinational remote sensing systems, with some licensees electing to receive radiofrequency licenses from other nations while seeking a NOAA remote sensing license in the United States. CRSRA is also sensitive to emerging communications methods not currently licensed by FCC, meaning a satellite using such methods would not be subject to FCC disposal and orbital debris mitigation requirements. While systems with one or both of these characteristics may have disposal and orbital debris mitigation plans approved by foreign radiofrequency authorities, CRSRA seeks to provide guidance on how licensees may satisfy the disposal condition in their CRSRA license.

B. Purpose and Objectives

CRSRA is seeking comments and suggestions from the remote sensing industry to identify whether CRSRA should contemplate issuing:

(1) A narrow rulemaking pertaining to the subsection (b)(4) license requirement that exists in all of its licenses;

(2) A narrow rulemaking pertaining to the subsection (b)(4) requirement for only those satellites without FCC licenses; or

(3) Narrow guidance not rising to the level of a rulemaking for licensees without FCC licenses, to clarify acceptable means of compliance with their existing license condition.

CRSRA is also seeking comments about how any narrow rulemakings or guidance should address existing licenses and what form the rulemaking or guidance should take.

II. Request for Comment

CRSRA welcomes industry comments, questions, and suggestions on matters related to the above discussion. CRSRA would especially appreciate any responses in writing to the following topics:

1. Articulate the benefits and drawbacks of CRSRA clarifying its supervision of remote sensing system disposal and orbital debris mitigation under its existing authority. Articulate how CRSRA’s decision to undertake a narrow rulemaking pertaining to all remote sensing systems, a narrow rulemaking only pertaining to licensees not licensed by the FCC, or limited guidance to licensees not licensed by the FCC would impact these benefits and drawbacks.

2. Should CRSRA choose to exercise its existing authority for disposal and orbital debris mitigation, recommend which industry standards and best practices CRSRA should consider when developing the definitions, revised condition language, and disposal and orbital debris mitigation plan assessment.

3. The current subsection (b)(4) license requirement states: “Upon termination of operations under the license, make disposition of any satellites in space in a manner satisfactory to the President.” CRSRA defines termination of operations as (1) to irreversibly render the remote sensing system incapable of being operated; (2) to passivate the system such that it cannot be operated; or (3) to become incapable of operating the system due to its natural end-of-life or anomaly, and to cease attempts to communicate as a result thereof. Comment on whether this definition is complete or omits other means by which operations could terminate.

4. Prior regulations required licensees to “obtain approval from the Assistant Administrator of all plans and procedures for the disposition of satellites as part of the application process” in order to “make disposition of a satellite in space.” Former 15 CFR 960.11(b)(12) (2006). Under this requirement, CRSRA approved disposal plans including atmospheric re-entry, maneuvering to a storage orbit, or direct

retrieval. Comment if this list remains comprehensive or if additional means or methods of disposal should be considered.

5. Recommend the type and content of documentation regarding disposal and orbital debris mitigation plans CRSRA should require to be submitted should CRSRA choose to exercise its existing authority for disposal and orbital debris mitigation.

6. Describe if there are disposal and orbital debris mitigation considerations that are unique to remote sensing systems (meaning they may not exist for other types of space systems) or that are of higher importance or priority for remote sensing systems than other types of space systems.

7. Recommend methods by which CRSRA could verify compliance with the license requirement to make disposition of satellites.

Please note that this is a request for information (RFI) only. In accordance with the implementing regulations of the Paperwork Reduction Act of 1995 (PRA), specifically 5 CFR 1320.3(h)(4), this general solicitation is exempt from the PRA. Facts or opinions submitted in response to general solicitations of comments from the public, published in the **Federal Register** or other publications, regardless of the form or format thereof, provided that no person is required to supply specific information pertaining to the commenter, other than that necessary for self-identification, as a condition of the agency’s full consideration, are not generally considered information collections and therefore not subject to the PRA.

Richard DalBello,
Director.

[FR Doc. 2024–05004 Filed 3–7–24; 8:45 am]

BILLING CODE 3511–43–P

DEPARTMENT OF COMMERCE

National Oceanic and Atmospheric Administration

[RTID 0648–XD717]

Takes of Marine Mammals Incidental to Specified Activities; Taking Marine Mammals Incidental to the Naval Magazine Indian Island Ammunition Wharf Maintenance and Pile Replacement Project, Puget Sound, Washington

AGENCY: National Marine Fisheries Service (NMFS), National Oceanic and Atmospheric Administration (NOAA), Commerce.

ACTION: Notice of issuance of letter of authorization.

SUMMARY: In accordance with the Marine Mammal Protection Act (MMPA), as amended, and implementing regulations, notification is hereby given that a Letter of Authorization (LOA) has been issued to the U.S. Navy (Navy) for the take of marine mammals incidental to construction activities at the Ammunition Wharf at Naval Magazine (NAVMAG) Indian Island in Puget Sound, Washington.

DATES: LOA effective from October 1, 2024, until September 30, 2029.

ADDRESSES: The LOA and supporting documentation are available online at: <https://www.fisheries.noaa.gov/action/incidental-take-authorization-taking-marine-mammals-incidental-naval-magazine-indian-island>. In case of problems accessing these documents, please call the contact listed below (see **FOR FURTHER INFORMATION CONTACT**).

FOR FURTHER INFORMATION CONTACT: Robert Pauline, Office of Protected Resources, NMFS, (301) 427-8401.

SUPPLEMENTARY INFORMATION:

Background

Sections 101(a)(5)(A) and (D) of the MMPA (16 U.S.C. 1361 *et seq.*) direct the Secretary of Commerce to allow, upon request, the incidental, but not intentional, taking of small numbers of marine mammals by U.S. citizens who engage in a specified activity (other than commercial fishing) within a specified geographical region if certain findings are made and either regulations are issued or, if the taking is limited to harassment, a notice of a proposed authorization is provided to the public for review.

An authorization for incidental takings shall be granted if NMFS finds that the taking will have a negligible impact on the species or stock(s), will not have an unmitigable adverse impact on the availability of the species or stock(s) for subsistence uses (where relevant), and if the permissible methods of taking and requirements pertaining to the mitigation, monitoring and reporting of such takings are set forth. NMFS has defined “negligible impact” in 50 CFR 216.103 as an impact resulting from the specified activity that cannot be reasonably expected to, and is not reasonably likely to, adversely affect the species or stock through effects on annual rates of recruitment or survival.

Except with respect to certain activities not pertinent here, the MMPA defines “harassment” as: any act of pursuit, torment, or annoyance which:

(i) has the potential to injure a marine mammal or marine mammal stock in the wild (Level A harassment); or (ii) has the potential to disturb a marine mammal or marine mammal stock in the wild by causing disruption of behavioral patterns, including, but not limited to, migration, breathing, nursing, breeding, feeding, or sheltering (Level B harassment).

Summary of Request

On January 29, 2024, we issued a final rule upon request from the Navy for authorization to take marine mammals incidental to construction activities (89 FR 5674). The Navy plans to engage in maintenance and pile replacement construction activities at NAVMAG.

This construction will include use of vibratory pile driving and removal, and impact pile driving. The use of both vibratory and impact pile driving is expected to produce underwater sound at levels that have the potential to result in Levels A and B harassment of marine mammals.

Authorization

We have issued a LOA to Navy authorizing the take of marine mammals incidental to construction activities, as described above. Take of marine mammals will be minimized through the implementation of the following planned mitigation measures: (1) required monitoring of the construction area to detect the presence of marine mammals before beginning construction activities; (2) shutdown of construction activities under certain circumstances to avoid injury of marine mammals; (3) soft start for impact pile driving to allow marine mammals the opportunity to leave the area prior to beginning impact pile driving at full power; and (4) use of bubble curtains to attenuate sound levels when impact driving steel piles. Additionally, the rule includes an adaptive management component that allows for timely modification of mitigation or monitoring measures based on new information, when appropriate. The Navy will submit reports as required.

Based on these findings and the information discussed in the preamble to the final rule, the activities described under this LOA will have a negligible impact on marine mammal stocks and will not have an unmitigable adverse impact on the availability of the affected marine mammal stock for subsistence uses.

Dated: March 4, 2024.

Catherine Marzin,
Deputy Director, Office of Protected Resources, National Marine Fisheries Service.
[FR Doc. 2024-04905 Filed 3-7-24; 8:45 am]

BILLING CODE 3510-22-P

DEPARTMENT OF COMMERCE

National Oceanic and Atmospheric Administration

Agency Information Collection Activities; Submission to the Office of Management and Budget (OMB) for Review and Approval; Comment Request; National Saltwater Angler Registry and State Exemption Program

AGENCY: National Oceanic & Atmospheric Administration (NOAA), Commerce.

ACTION: Notice of information collection, request for comment.

SUMMARY: The Department of Commerce, in accordance with the Paperwork Reduction Act of 1995 (PRA), invites the general public and other Federal agencies to comment on proposed, and continuing information collections, which helps us assess the impact of our information collection requirements and minimize the public’s reporting burden. The purpose of this notice is to allow for 60 days of public comment preceding submission of the collection to OMB.

DATES: To ensure consideration, comments regarding this proposed information collection must be received on or before May 7, 2024.

ADDRESSES: Interested persons are invited to submit written comments to Adrienne Thomas, NOAA PRA Officer, at NOAA.PRA@noaa.gov. Please reference OMB Control Number 0648-0578 in the subject line of your comments. Do not submit Confidential Business Information or otherwise sensitive or protected information.

FOR FURTHER INFORMATION CONTACT: Requests for additional information or specific questions related to collection activities should be directed to Lauren Dolinger Few, IT Specialist, National Marine Fisheries Service, Office of Science and Technology, 1315 East-West Hwy./FST1, Silver Spring, MD 21910, Phone: (301) 427-8127, lauren.dolinger.few@noaa.gov.

SUPPLEMENTARY INFORMATION:

I. Abstract

This request is for the extension of a currently approved collection. The National Saltwater Angler Registry Program and State Exemption Program

(Registry Program) was established to implement recommendations included in the review of national saltwater angling data collection programs conducted by the National Research Council (NRC) in 2005/2006, and the provisions of the Magnuson-Stevens Reauthorization Act, codified at Section 401(g) of the Magnuson-Stevens Fishery Conservation and Management Act (MSA), which require the Secretary of Commerce to commence improvements to recreational fisheries surveys, including establishing a national saltwater angler and for-hire vessel registry, by January 1, 2009. A final rule that includes regulatory measures to implement the Registry Program (RIN 0648-AW10) was adopted and codified in 50 CFR 600, subpart P.

The Registry Program collects identification and contact information from those anglers and for-hire vessels who are involved in recreational fishing in the United States Exclusive Economic Zone or for anadromous fish in any waters, unless the anglers or vessels are exempted from the registration requirement. Data collected includes—for anglers: Name, address, date of birth, telephone contact information and region(s) of the country in which they fish; for for-hire vessels: Owner and operator name, address, date of birth, telephone contact information, email address, vessel name and registration/documentation number and home port or primary operating area. This information is compiled into a national and/or series of regional registries that is being used to support surveys of recreational anglers and for-hire vessels to develop estimates of recreational angling effort.

II. Method of Collection

Persons may register online at a NOAA-maintained website. Registration cards, valid for one year from the date of issuance, are mailed to registrants.

III. Data

OMB Control Number: 0648-0578.

Form Number(s): None.

Type of Review: Extension of current information collection.

Affected Public: Individuals or households; business or other for-profit organizations.

Estimated Number of Respondents: 976.

Estimated Time per Response: 3 minutes.

Estimated Total Annual Burden Hours: 49.

Estimated Total Annual Cost to Public: 1,652.48.

Respondent's Obligation: Mandatory.

Legal Authority: Magnuson-Stevens Fishery Conservation and Management Act (MSA) 50 CFR 600, subpart P.

IV. Request for Comments

We are soliciting public comments to permit the Department/Bureau to: (a) Evaluate whether the proposed information collection is necessary for the proper functions of the Department, including whether the information will have practical utility; (b) Evaluate the accuracy of our estimate of the time and cost burden for this proposed collection, including the validity of the methodology and assumptions used; (c) Evaluate ways to enhance the quality, utility, and clarity of the information to be collected; and (d) Minimize the reporting burden on those who are to respond, including the use of automated collection techniques or other forms of information technology.

Comments that you submit in response to this notice are a matter of public record. We will include or summarize each comment in our request to OMB to approve this ICR. Before including your address, phone number, email address, or other personal identifying information in your comment, you should be aware that your entire comment—including your personal identifying information—may be made publicly available at any time. While you may ask us in your comment to withhold your personal identifying information from public review, we cannot guarantee that we will be able to do so.

Sheleen Dumas,

Department PRA Clearance Officer, Office of the Under Secretary for Economic Affairs, Commerce Department.

[FR Doc. 2024-05002 Filed 3-7-24; 8:45 am]

BILLING CODE 3510-22-P

DEPARTMENT OF COMMERCE

National Oceanic and Atmospheric Administration

Agency Information Collection Activities; Submission to the Office of Management and Budget (OMB) for Review and Approval; Comment Request; Sea Grant Program Application Requirements for Grants, for Sea Grant Fellowships, Including the Dean John A. Knauss Marine Policy Fellowships, and for Designation as a Sea Grant College or Sea Grant Institution

The Department of Commerce will submit the following information collection request to the Office of Management and Budget (OMB) for

review and clearance in accordance with the Paperwork Reduction Act of 1995, on or after the date of publication of this notice. We invite the general public and other Federal agencies to comment on proposed, and continuing information collections, which helps us assess the impact of our information collection requirements and minimize the public's reporting burden. Public comments were previously requested via the **Federal Register** on December 13, 2023, during a 60-day comment period. This notice allows for an additional 30 days for public comments.

Agency: National Oceanic and Atmospheric Administration (NOAA), Commerce.

Title: Sea Grant Program Application Requirements for Grants, for Sea Grant Fellowships, including the Dean John A. Knauss Marine Policy Fellowships, and for Designation as a Sea Grant College or Sea Grant Institution.

OMB Control Number: 0648-0362.

Form Number(s): NOAA Forms 90-1, 90-2, and 90-4.

Type of Request: Regular submission [extension of a current information collection].

Number of Respondents: 680.

Average Hours per Response: 30 minutes for a Sea Grant Control form; 20 minutes for a Project Record Form; 15 minutes for a Sea Grant Budget form; and 20 hours for an application for designation as a Sea Grant college or Sea Grant institute.

Total Annual Burden Hours: 1,091.

Needs and Uses: This is a request for extension of an existing information collection.

The objectives of the National Sea Grant College Program, as stated in the Sea Grant legislation (33 U.S.C. 1121 *et seq.*) are to increase the understanding, assessments, development, utilization, and conservation of the Nation's ocean, coastal, and Great Lakes resources. It accomplishes these objectives by conducting research, education, and outreach programs. Grant monies are available for funding activities that help obtain the objectives of the Sea Grant Program. Both single and multi-project grants are awarded, with the latter representing approximately 80 percent of the total grant program. In addition to other standard grant application requirements, three forms are required with the grants. The Sea Grant Control Form (NOAA Form 90-1) is used to identify the organizations and personnel who would be involved in the grant and briefly summarize the proposed activities under the grant. The Project Record Form (NOAA Form 90-2), which collects summary data on projects, helps the National Sea Grant Office (NSGO)

evaluate the proposals during its funding decisions. The Sea Grant Budget Form (NOAA Form 90–4) provides information similar to, but more detailed than, standardized budget forms SF–424A or SF–424C, and allows the NSGO to determine whether or not the breakdown cost of multi-project grant awards is reasonable. Collectively, the data supplied in these documents form the basis for many of NSGO’s responses to the Administration, the Congress, other agencies, and to the public about the scope of Sea Grant activities.

The National Sea Grant College Program Act (33 U.S.C. 1126) also provides for the designation of a public or private institution of higher education, institute, laboratory, or State or local agency as a Sea Grant college or Sea Grant institute. Applications are required for designation of Sea Grant Colleges and Sea Grant Institutes, although no forms are required. The data the collection provides helps the National Sea Grant Office determine the suitability of the applicant for meeting the standards and conditions for being a Sea Grant College as set forth in 33 U.S.C. 1126 and 15 CFR 918.5.

Affected Public: Academic and not-for-profit institutions; individuals or households; business or other for-profit organizations; State, local, or Tribal government.

Frequency: On occasion.

Respondent’s Obligation: Required to Obtain or Retain Benefits.

Legal Authority: 33 U.S.C. 1121 *et seq.*

This information collection request may be viewed at www.reginfo.gov. Follow the instructions to view the Department of Commerce collections currently under review by OMB.

Written comments and recommendations for the proposed information collection should be submitted within 30 days of the publication of this notice on the following website www.reginfo.gov/public/do/PRAMain. Find this particular information collection by selecting “Currently under 30-day Review—Open for Public Comments” or by using the search function and entering either the title of the collection or the OMB Control Number 0648–0362.

Sheleen Dumas,

Department PRA Clearance Officer, Office of the Under Secretary for Economic Affairs, Commerce Department.

[FR Doc. 2024–05003 Filed 3–7–24; 8:45 am]

BILLING CODE 3510-KA-P

DEPARTMENT OF COMMERCE

Patent and Trademark Office

[Docket No. PTO–P–2024–0009]

USPTO AI/ET Partnership: Public Symposium on Artificial Intelligence and Intellectual Property

AGENCY: Patent and Trademark Office, Department of Commerce.

ACTION: Notice of public meeting.

SUMMARY: The United States Patent and Trademark Office (USPTO) Artificial Intelligence (AI)/Emerging Technologies (ET) Partnership provides opportunities to bring stakeholders together through a series of engagements to share ideas, feedback, experiences, and insights regarding the intersection of intellectual property (IP) and AI/ET. To further the AI/ET Partnership, the USPTO will hold a public symposium on IP and AI virtually and in person at Loyola Law School on March 27, 2024. The symposium will facilitate the USPTO’s efforts to implement its obligations under the President’s Executive Order 14110, titled “Safe, Secure, and Trustworthy Development and Use of Artificial Intelligence.”

DATES: The symposium will take place on March 27, 2024, from 10 a.m. to 3 p.m. PT. Persons seeking to attend, either virtually or in person, must register by March 22, 2024, at the web page provided in the **ADDRESSES** section of this notice. Seating is limited for in-person attendance.

ADDRESSES: Information on registration is available at www.uspto.gov/initiatives/artificial-intelligence/ai-and-emerging-technology-partnership-engagement-and-events/public-symposium-ai-and-ip. The public symposium will be held virtually and in-person at the Fritz B. Burns Lounge within the Burns Academic Center, Loyola Law School, Loyola Marymount University, 919 Albany St., Los Angeles, CA 90015. All major entrances to the building are accessible to people with disabilities. Registration is required for both virtual and in-person attendance. Because in-person attendance is limited, the USPTO advises anyone wishing to attend in person to register early.

If you are an individual with a disability and would like to request a reasonable accommodation, please submit your request to AIPartnership@uspto.gov as soon as possible or at least seven business days prior to the symposium.

FOR FURTHER INFORMATION CONTACT:

Srilakshmi Kumar, Supervisory Patent Examiner, at 571–272–7769 or

srilakshmi.kumar@uspto.gov. You can also send inquiries to AIPartnership@uspto.gov. Please direct all media inquiries to the USPTO’s Office of the Chief Communications Officer at 571–272–8400.

SUPPLEMENTARY INFORMATION: The USPTO AI/ET Partnership provides opportunities to bring stakeholders together through a series of engagements to share ideas, feedback, experiences, and insights regarding the intersection of IP and AI/ET. Several of the previous AI/ET Partnership events focused on patent-related inventorship issues. For example, participants in the inaugural AI/ET Partnership meeting in June 2022 discussed patent policy issues related to AI/ET inventions, including subject matter eligibility, disclosure, and inventorship. Additionally, the AI/ET Partnership meeting held in February 2023 focused on various IP policy issues with respect to AI-driven innovation, including ways to address inventions created with significant AI contributions, and unanticipated IP challenges from AI-driven innovation.

The AI/ET Partnership meeting on March 27, 2024, will build on the above-mentioned meetings and will feature panel discussions by experts in the fields of patent, trademark, and copyright law that focus on: (1) a comparison of copyright and patent law approaches to the type and level of human contribution needed to satisfy authorship and inventorship requirements; (2) ongoing copyright litigation involving generative AI; and (3) laws and policy considerations surrounding name, image, and likeness (NIL) issues, including the intersection of NIL and generative AI.

This USPTO event is intended to complement, but not duplicate, the ongoing initiatives of the U.S. Copyright Office to examine copyright law and policy issues raised by AI technologies, which are described at www.copyright.gov/ai/.

Instructions and Information on the Public Symposium

The public symposium will take place virtually and in person at the Fritz B. Burns Lounge within the Burns Academic Center, Loyola Law School, Loyola Marymount University, 919 Albany St., Los Angeles, CA 90015, on March 27, 2024, from 10 a.m. to 3 p.m. PT. The agenda is available on the USPTO website at www.uspto.gov/initiatives/artificial-intelligence/ai-and-emerging-technology-partnership-engagement-and-events/public-symposium-ai-and-ip. You can register

to attend the event on the same web page.

Katherine K. Vidal,

Under Secretary of Commerce for Intellectual Property and Director of the United States Patent and Trademark Office.

[FR Doc. 2024-04971 Filed 3-7-24; 8:45 am]

BILLING CODE 3510-16-P

COMMISSION OF FINE ARTS

Notice of Meeting

Per 45 CFR chapter XXI section 2102.3, the next meeting of the U.S. Commission of Fine Arts is scheduled for March 21, 2024, at 9 a.m. and will be held via online videoconference. Items of discussion may include buildings, infrastructure, parks, memorials, and public art.

Draft agendas, the link to register for the online public meeting, and additional information regarding the Commission are available on our website: www.cfa.gov. Inquiries regarding the agenda, as well as any public testimony, should be addressed to Thomas Luebke, Secretary, U.S. Commission of Fine Arts, at the above address; by emailing cfastaff@cfa.gov; or by calling 202-504-2200. Individuals requiring sign language interpretation for the hearing impaired should contact the Secretary at least 10 days before the meeting date.

Dated March 4, 2024 in Washington, DC.

Zakiya N. Walters,

Administrative Officer.

[FR Doc. 2024-04949 Filed 3-7-24; 8:45 am]

BILLING CODE 6330-01-P

COMMITTEE FOR PURCHASE FROM PEOPLE WHO ARE BLIND OR SEVERELY DISABLED

Procurement List; Proposed Deletions

AGENCY: Committee for Purchase From People Who Are Blind or Severely Disabled.

ACTION: Proposed deletions from the Procurement List.

SUMMARY: The Committee is proposing to delete product(s) and service(s) to the Procurement List that were furnished by nonprofit agencies employing persons who are blind or have other severe disabilities.

DATES: Comments must be received on or before: April 07, 2024.

ADDRESSES: Committee for Purchase From People Who Are Blind or Severely Disabled, 355 E Street SW, Suite 325, Washington, DC 20024.

FOR FURTHER INFORMATION CONTACT: For further information or to submit comments contact: Michael R. Jurkowski, Telephone: (703) 785-6404 or email CMTEFedReg@AbilityOne.gov.

SUPPLEMENTARY INFORMATION: This notice is published pursuant to 41 U.S.C. 8503 (a)(2) and 41 CFR 51-2.3. Its purpose is to provide interested persons an opportunity to submit comments on the proposed actions.

Deletions

The following product(s) and service(s) are proposed for deletion from the Procurement List:

Product(s)

NSN(s)—Product Name(s):

7350-01-574-8714—Cup, Paper, Biobased, Biodegradable, Hot, Tall Style, White, 8 oz, with Handle

7350-01-574-8735—Cup, Paper, Biobased, Biodegradable, Cold, Tall Style, White, 16 oz

7350-01-574-8736—Cup, Paper, Biobased, Biodegradable, Hot, Tall Style, White, 16 oz

7350-01-574-8730—Cup, Paper, Biobased, Biodegradable, Hot and Cold, Tall Style, White, 6 oz

7350-01-574-8732—Cup, Paper, Biobased, Biodegradable, Cold, Tall Style, White, 9 oz

7350-01-574-8733—Cup, Paper, Biobased, Biodegradable, Cold, Tall Style, White, 12 oz

7350-01-574-8734—Cup, Paper, Biobased, Biodegradable, Hot, Tall Style, White, 12 oz

7350-01-574-8737—Cup, Paper, Biobased, Biodegradable, Hot, Tall Style, White, 8 oz

7350-01-574-8717—Cup, Paper, Biobased, Biodegradable, Hot, Squat Style, White, 12 oz

7350-01-645-7874—Cup, Disposable, Paper, BioBased, Cold Beverage, White, 21 oz.

Authorized Source of Supply: The Lighthouse for the Blind in New Orleans, Inc., New Orleans, LA

Contracting Activity: GSA/FSS GREATER SOUTHWEST ACQUISITI, FORT WORTH, TX

Service(s)

Service Type: Switchboard Operation
Mandatory for: Greater Los Angeles Health Care System: Los Angeles Ambulatory Care Center, Los Angeles, CA

Mandatory for: Greater Los Angeles Health Care System: Sepulveda Ambulatory Care Center

Mandatory for: Greater Los Angeles Health Care System: VA Medical Center, West Los Angeles

Authorized Source of Supply: Lighthouse for the Blind of Houston, Houston, TX

Contracting Activity: VETERANS AFFAIRS, DEPARTMENT OF, NAC

Service Type: Supply Room Support Services
Mandatory for: DCMA, DCMA Headquarters, 3901 A Ave, Fort Gregg-Adams, VA

Authorized Source of Supply: Virginia Industries for the Blind, Charlottesville, VA

Contracting Activity: DEFENSE CONTRACT MANAGEMENT AGENCY (DCMA), DEFENSE CONTRACT MANAGEMENT OFFICE

Michael R. Jurkowski,

Director, Business Operations.

[FR Doc. 2024-04960 Filed 3-7-24; 8:45 am]

BILLING CODE 6353-01-P

COMMITTEE FOR PURCHASE FROM PEOPLE WHO ARE BLIND OR SEVERELY DISABLED

Procurement List; Deletions

AGENCY: Committee for Purchase From People Who Are Blind or Severely Disabled.

ACTION: Deletions from the Procurement List.

SUMMARY: This action deletes product(s) and service(s) from the Procurement List that were furnished by nonprofit agencies employing persons who are blind or have other severe disabilities.

DATES: Date added to and deleted from the Procurement List: April 07, 2024.

ADDRESSES: Committee for Purchase From People Who Are Blind or Severely Disabled, 355 E Street SW, Suite 325, Washington, DC 20024.

FOR FURTHER INFORMATION CONTACT: Michael R. Jurkowski, Telephone: (703) 785-6404, or email CMTEFedReg@AbilityOne.gov.

SUPPLEMENTARY INFORMATION:

Deletions

On 2/2/2024, the Committee for Purchase From People Who Are Blind or Severely Disabled published notice of proposed deletions from the Procurement List. This notice is published pursuant to 41 U.S.C. 8503 (a)(2) and 41 CFR 51-2.3.

After consideration of the relevant matter presented, the Committee has determined that the product(s) and service(s) listed below are no longer suitable for procurement by the Federal Government under 41 U.S.C. 8501-8506 and 41 CFR 51-2.4.

Regulatory Flexibility Act Certification

I certify that the following action will not have a significant impact on a substantial number of small entities. The major factors considered for this certification were:

1. The action will not result in additional reporting, recordkeeping or other compliance requirements for small entities.

2. The action may result in authorizing small entities to furnish the product(s) and service(s) to the Government.

3. There are no known regulatory alternatives which would accomplish the objectives of the Javits-Wagner-O'Day Act (41 U.S.C. 8501–8506) in connection with the product(s) and service(s) deleted from the Procurement List.

End of Certification

Accordingly, the following product(s) and service(s) are deleted from the Procurement List:

Product(s)

NSN(s)—Product Name(s): 8460–01–113–7575—Envelope Case, Map and Photograph

Contracting Activity: DLA TROOP SUPPORT, PHILADELPHIA, PA

NSN(s)—Product Name(s):

6545–01–525–9821—Mass Casualty Case

6545–01–526–0062—Splint Module

6545–01–526–0423—Mass Casualty First Aid Kit

Authorized Source of Supply: Chautauqua County Chapter, NYSARC, Jamestown, NY

Contracting Activity: DLA TROOP SUPPORT, PHILADELPHIA, PA

NSN(s)—Product Name(s):

6135–00–904–6780—Battery, Non-Rechargeable,

Button, 1.55V, Silver Oxide, NEDA

1133SO, EA/1

Authorized Source of Supply: Eastern Carolina Vocational Center, Inc., Greenville, NC

Contracting Activity: DLA LAND AND MARITIME, COLUMBUS, OH

Service(s)

Service Type: Janitorial/Custodial

Mandatory for: U.S. Army Reserve, PFC Schooley USARC, AMSA 89, 125A Armory Road, Galax, VA

Authorized Source of Supply: Mount Rogers Community Services Board, Wytheville, VA

Contracting Activity: DEPT OF THE ARMY, W6QK ACC–PICA

Michael R. Jurkowski,

Director, Business Operations.

[FR Doc. 2024–04961 Filed 3–7–24; 8:45 am]

BILLING CODE 6353–01–P

DEPARTMENT OF EDUCATION

Applications for New Awards; Gaining Early Awareness and Readiness for Undergraduate Programs (State Grants)

AGENCY: Office of Postsecondary Education, Department of Education.

ACTION: Notice.

SUMMARY: The Department of Education (Department) is issuing a notice inviting

applications for new awards for fiscal year (FY) 2024 for Gaining Early Awareness and Readiness for Undergraduate Programs (GEAR UP) State Grants, Assistance Listing Number 84.334S. This notice relates to the approved information collection under OMB control number 1840–0821, Application for GEAR UP State Grants.

DATES:

Applications Available: March 8, 2024.

Deadline for Transmittal of Applications: May 7, 2024.

Deadline for Intergovernmental Review: July 8, 2024.

ADDRESSES: For the addresses for obtaining and submitting an application, please refer to our Common Instructions for Applicants to Department of Education Discretionary Grant Programs, published in the **Federal Register** on December 7, 2022 (87 FR 75045), and available at www.federalregister.gov/d/2022-26554.

FOR FURTHER INFORMATION CONTACT: Ben Witthoefft, U.S. Department of Education, 400 Maryland Avenue SW, 5th floor, Washington, DC 20202–6450. Telephone: 202–453–7576. Email: Ben.Witthoefft@ed.gov.

If you are deaf, hard of hearing, or have a speech disability and wish to access telecommunications relay services, please dial 7–1–1.

SUPPLEMENTARY INFORMATION:

Full Text of Announcement

I. Funding Opportunity Description

Purpose of Program: The GEAR UP program is a discretionary grant program that encourages eligible entities to provide support, and maintain a commitment, to eligible students from low-income backgrounds, including students with disabilities, to assist the students in obtaining a secondary school diploma (or its recognized equivalent) and to prepare for and succeed in postsecondary education. Under the GEAR UP program, the Department awards grants to two types of entities: (1) States and (2) Partnerships consisting of at least one degree-granting institution of higher education (IHE) and at least one local educational agency (LEA).

Background: In this notice, the Department invites applications for State grants only. We will invite applications for Partnership grants in another notice published in the **Federal Register**. Required services under the GEAR UP program are specified in section 404D(a) of the Higher Education Act of 1965, as amended (HEA) (20 U.S.C. 1070a–24(a)), and permissible services under the GEAR UP program

are specified in section 404D(b) and (c) of the HEA (20 U.S.C. 1070a–24(b) and (c)). Grantee activities must include providing financial aid information for postsecondary education, encouraging enrollment in rigorous and challenging coursework in order to reduce the need for remediation at the postsecondary education level, implementing activities to improve the number of participating students who obtain a secondary school diploma and who complete applications for and enroll in a program of postsecondary education, and providing scholarships as specified in section 404E of the HEA. Activities may also include mentoring; tutoring; supporting dual or concurrent enrollment programs; providing special programs or tutoring in science, technology, engineering, or mathematics (STEM); academic and career counseling; financial and economic literacy education; and exposure to college campuses. Additional permissible activities for State grantees are specified in sections 404D(b) and (c) of the HEA.

Priorities: This notice contains four competitive preference priorities. In accordance with 34 CFR 75.105(b)(2)(ii) and (iv), Competitive Preference Priority 1 is from section 404A(b)(3) of the HEA (20 U.S.C. 1070a–21(b)(3)) and the GEAR UP program regulations (34 CFR 694.19). Competitive Preference Priorities 2 and 3 are from the Secretary's Final Supplemental Priorities and Definitions for Discretionary Grant Programs, published in the **Federal Register** on December 10, 2021 (86 FR 70612) (Supplemental Priorities). Competitive Preference Priority 4 is from 34 CFR 75.226(d).

Competitive Preference Priorities: For FY 2024 and any subsequent year in which we make awards from the list of unfunded applications from this competition, these priorities are competitive preference priorities. Under 34 CFR 75.105(c)(2)(i), we award up to an additional 15 points to an application, depending on how well the application meets the competitive preference priorities.

These priorities are:

Competitive Preference Priority 1—Successful State GEAR UP grant prior to August 14, 2008 (up to 2 points).

We give priority to an eligible applicant for a State GEAR UP grant that has (a) carried out a successful State GEAR UP grant prior to August 14, 2008, determined on the basis of data (including outcome data) submitted by the applicant as part of its annual and final performance reports, and the applicant's history of compliance with applicable statutory and regulatory

requirements; and (b) a prior demonstrated commitment to early intervention leading to college access through collaboration and replication of successful strategies.

Competitive Preference Priority 2—Increasing Postsecondary Education Access, Affordability, Completion, and Post-Enrollment Success (up to 5 points).

Projects that are designed to increase postsecondary access, affordability, completion, and success for underserved students by establishing a system of high-quality data collection and analysis, such as data on persistence, retention, completion, and post-college outcomes, for transparency, accountability, and institutional improvement.

Competitive Preference Priority 3—Meeting Student Social, Emotional, and Academic Needs (up to 5 Points).

Projects that are designed to improve students' social, emotional, academic, and career development, with a focus on underserved students, through creating education or work-based settings that are supportive, positive, identity-safe and inclusive with regard to race, ethnicity, culture, language, and disability status, through developing trusting relationships between students (including underserved students), educators, families, and community partners.

Competitive Preference Priority 4—Moderate Evidence (3 points).

Applications supported by evidence that meets the conditions in the definition of “moderate evidence” (as defined in this notice).

Note: To address this priority, an applicant may submit up to two study citations that it believes support the implementation of a GEAR UP authorized activity proposed in the application and that meet the moderate evidence standard. For State grantees, required GEAR UP services are specified in section 404D(a) of the HEA (20 U.S.C. 1070a–24(a)), and permissible services are specified in section 404D(b) and (c) of the HEA (20 U.S.C. 1070a–24(b) and (c)).

Applicants can cite What Works Clearinghouse (WWC) intervention reports, WWC practice guides, or individual studies, including those already listed in the Department's WWC Database of Individual Studies¹ and those that have not yet been reviewed by the WWC.

The proposed studies must be cited in the application section for Competitive Preference Priority 4 as well as on the Evidence Form. Applicants must also

describe: (1) the project component(s) from the cited research they intend to implement in their GEAR UP project, (2) the relevant outcome(s) that are included in both the study (or WWC practice guide or intervention report) and in the proposed project, (3) the research findings suggesting a favorable relationship between the project component and the relevant outcome, and (4) how the population and/or settings in the cited research overlap with that of the proposed project. The Department will review the research cited by the applicant to determine whether it meets the requirements for moderate evidence and whether it is sufficiently aligned with the proposed project.

Definitions: The definitions of “demonstrates a rationale,” “experimental study,” “logic model,” “moderate evidence,” “project component,” “promising evidence,” “quasi-experimental design study,” “relevant outcome,” and “What Works Clearinghouse (WWC) Handbooks (WWC Handbooks)” are from 34 CFR 77.1(c). The definitions of “children or students with disabilities,” “disconnected youth,” “English learner,” and “underserved student” are from the Supplemental Priorities.

Demonstrates a rationale means a key project component included in the project's logic model is informed by research or evaluation findings that suggest the project component is likely to improve relevant outcomes.

Experimental study means a study that is designed to compare outcomes between two groups of individuals (such as students) that are otherwise equivalent except for their assignment to either a treatment group receiving a project component or a control group that does not. Randomized controlled trials, regression discontinuity design studies, and single-case design studies are the specific types of experimental studies that, depending on their design and implementation (e.g., sample attrition in randomized controlled trials and regression discontinuity design studies), can meet What Works Clearinghouse (WWC) standards without reservations as described in the WWC Handbooks:

(i) A randomized controlled trial employs random assignment of, for example, students, teachers, classrooms, or schools to receive the project component being evaluated (the treatment group) or not to receive the project component (the control group).

(ii) A regression discontinuity design study assigns the project component being evaluated using a measured variable (e.g., assigning students reading

below a cutoff score to tutoring or developmental education classes) and controls for that variable in the analysis of outcomes.

(iii) A single-case design study uses observations of a single case (e.g., a student eligible for a behavioral intervention) over time in the absence and presence of a controlled treatment manipulation to determine whether the outcome is systematically related to the treatment.

Logic model (also referred to as a theory of action) means a framework that identifies key project components of the proposed project (i.e., the active “ingredients” that are hypothesized to be critical to achieving the relevant outcomes) and describes the theoretical and operational relationships among the key project components and relevant outcomes.

Note: In developing logic models, applicants may want to use resources such as the Regional Educational Laboratory Program's (REL Pacific) Education Logic Model Application, available at <https://ies.ed.gov/ncee/edlabs/regions/pacific/elm.asp>. Other sources include: https://ies.ed.gov/ncee/edlabs/regions/pacific/pdf/REL_2014025.pdf, https://ies.ed.gov/ncee/edlabs/regions/pacific/pdf/REL_2014007.pdf, and https://ies.ed.gov/ncee/edlabs/regions/northeast/pdf/REL_2015057.pdf.

Moderate evidence means that there is evidence of effectiveness of a key project component in improving a relevant outcome for a sample that overlaps with the populations or settings proposed to receive that component, based on a relevant finding from one of the following:

(i) A practice guide prepared by the WWC using version 2.1, 3.0, 4.0, or 4.1 of the WWC Handbooks reporting a “strong evidence base” or “moderate evidence base” for the corresponding practice guide recommendation;

(ii) An intervention report prepared by the WWC using version 2.1, 3.0, 4.0, or 4.1 of the WWC Handbooks reporting a “positive effect” or “potentially positive effect” on a relevant outcome based on a “medium to large” extent of evidence, with no reporting of a “negative effect” or “potentially negative effect” on a relevant outcome; or

(iii) A single experimental study or quasi-experimental design study reviewed and reported by the WWC using version 2.1, 3.0, 4.0, or 4.1 of the WWC Handbooks, or otherwise assessed by the Department using version 4.1 of the WWC Handbooks, as appropriate, and that—

¹ <http://ies.ed.gov/ncee/wwc/ReviewedStudies#>.

(A) Meets WWC standards with or without reservations;

(B) Includes at least one statistically significant and positive (*i.e.*, favorable) effect on a relevant outcome;

(C) Includes no overriding statistically significant and negative effects on relevant outcomes reported in the study or in a corresponding WWC intervention report prepared under version 2.1, 3.0, 4.0, or 4.1 of the WWC Handbooks; and

(D) Is based on a sample from more than one site (*e.g.*, State, county, city, school district, or postsecondary campus) and includes at least 350 students or other individuals across sites. Multiple studies of the same project component that each meet requirements in paragraphs (iii)(A), (B), and (C) of this definition may together satisfy the requirement in this paragraph (iii)(D).

Note: The WWC Procedures and Standards Handbook (Version 4.1), as well as the more recent WWC Handbook released in August 2022 (Version 5.0), are available at <https://ies.ed.gov/ncee/wwc/Handbooks>.

Project component means an activity, strategy, intervention, process, product, practice, or policy included in a project. Evidence may pertain to an individual project component or to a combination of project components (*e.g.*, training teachers on instructional practices for English learners and follow-on coaching for these teachers).

Promising evidence means that there is evidence of the effectiveness of a key project component in improving a relevant outcome, based on a relevant finding from one of the following:

(i) A practice guide prepared by WWC reporting a “strong evidence base” or “moderate evidence base” for the corresponding practice guide recommendation;

(ii) An intervention report prepared by the WWC reporting a “positive effect” or “potentially positive effect” on a relevant outcome with no reporting of a “negative effect” or “potentially negative effect” on a relevant outcome; or

(iii) A single study assessed by the Department, as appropriate, that—

(A) Is an experimental study, a quasi-experimental design study, or a well-designed and well-implemented correlational study with statistical controls for selection bias (*e.g.*, a study using regression methods to account for differences between a treatment group and a comparison group); and

(B) Includes at least one statistically significant and positive (*i.e.*, favorable) effect on a relevant outcome.

Quasi-experimental design study means a study using a design that attempts to approximate an experimental study by identifying a comparison group that is similar to the treatment group in important respects. This type of study, depending on design and implementation (*e.g.*, establishment of baseline equivalence of the groups being compared), can meet WWC standards with reservations, as described in the WWC Handbooks.

Relevant outcome means the student outcome(s) or other outcome(s) the key project component is designed to improve, consistent with the specific goals of the program.

Underserved student means a student in postsecondary education in one or more of the following subgroups:

(a) A student who is living in poverty or is served by schools with high concentrations of students living in poverty.

(b) A student of color.

(c) A student who is a member of a federally recognized Indian Tribe.

(d) An English learner.

(e) A child or student with a disability.

(f) A disconnected youth.

(g) A migrant student.

(h) A student experiencing homelessness or housing insecurity.

(i) A lesbian, gay, bisexual, transgender, queer or questioning, or intersex (LGBTQI+) student.

(j) A student who is in foster care.

(k) A pregnant, parenting, or caregiving student.

(l) A student who is the first in their family to attend postsecondary education.

(m) A student who is enrolled in or is seeking to enroll in postsecondary education who is eligible for a Pell Grant.

For purposes of the definition of *underserved student* only—

Children or students with disabilities means children with disabilities as defined in section 602(3) of the Individuals with Disabilities Education Act (IDEA) (20 U.S.C. 1401(3)) and 34 CFR 300.8, or students with disabilities, as defined in the Rehabilitation Act of 1973 (29 U.S.C. 705(37), 705(202)(B));

Disconnected youth means an individual, between the ages 14 and 24, who may be from a low-income background, experiences homelessness, is in foster care, is involved in the justice system, or is not working or not enrolled in (or at risk of dropping out of) an educational institution; and

English learner means an individual who is an English learner as defined in section 8101(20) of the Elementary and Secondary Education Act of 1965, as

amended, or an individual who is an English language learner as defined in section 203(7) of the Workforce Innovation and Opportunity Act.

What Works Clearinghouse (WWC) Handbooks (WWC Handbooks) means the standards and procedures set forth in the WWC Standards Handbook, Versions 4.0 or 4.1, and WWC Procedures Handbook, Versions 4.0 or 4.1, or in the WWC Procedures and Standards Handbook, Version 3.0 or Version 2.1 (all incorporated by reference, see § 77.2). Study findings eligible for review under WWC standards can meet WWC standards without reservations, meet WWC standards with reservations, or not meet WWC standards. WWC practice guides and intervention reports include findings from systematic reviews of evidence as described in the WWC Handbooks documentation.

Note: The WWC Procedures and Standards Handbook (Version 4.1), as well as the more recent WWC Handbook released in August 2022 (Version 5.0), are available at <https://ies.ed.gov/ncee/wwc/Handbooks>.

Program Authority: 20 U.S.C. 1070a–21—1070a–28.

Note: Projects will be awarded and must be operated in a manner consistent with the nondiscrimination requirements contained in Federal civil rights laws.

Applicable Regulations: (a) The Education Department General Administrative Regulations (EDGAR) in 34 CFR parts 75, 77, 79, 81, 82, 84, 97, 98, and 99. (b) The Office of Management and Budget Guidelines to Agencies on Governmentwide Debarment and Suspension (Nonprocurement) in 2 CFR part 180, as adopted and amended as regulations of the Department in 2 CFR part 3485. (c) The Uniform Administrative Requirements, Cost Principles, and Audit Requirements for Federal Awards in 2 CFR part 200 (Uniform Guidance), as adopted and amended as regulations of the Department in 2 CFR part 3474. (d) The regulations for this program in 34 CFR part 694. (e) The Supplemental Priorities.

II. Award Information

Type of Award: Discretionary grants.

Estimated Available Funds: The Administration has requested \$408,000,000 for GEAR UP for FY 2024, of which we intend to use an estimated \$40,000,000 for the State competition. The actual level of funding, if any, depends on final congressional action. However, we are inviting applications to allow enough time to complete the grant

process if Congress appropriates funds for this program.

Contingent upon the availability of funds and the quality of applications, we may make additional awards in subsequent years from the list of unfunded applications from this competition.

Estimated Range of Awards: \$3,000,000–\$5,000,000.

Estimated Average Size of Awards: \$4,000,000.

Maximum Award: We will not make an award for a State grant exceeding \$5,000,000 for a single budget period of 12 months. Additionally, no funding will be awarded for increases in years 2 through 7.

Estimated Number of Awards: 10.

Note: The Department is not bound by any estimates in this notice.

Project Period: Either 72 months or 84 months.

Note: An applicant that wishes to seek funding for a seventh project year (*i.e.*, for a project period greater than 72 months) in order to provide project services to GEAR UP students through their first year of attendance at an institution of higher education (IHE) must propose to do so in its application.

III. Eligibility Information

1. *Eligible Applicants:* States (as defined in section 103(20) of the HEA (20 U.S.C. 1003(20)), which includes the Commonwealth of Puerto Rico, the District of Columbia, Guam, American Samoa, the United States Virgin Islands, the Commonwealth of the Northern Mariana Islands, and the Freely Associated States. Per congressional direction in House Report 117–403 2023 (Pub. L. 117–328), only States without an active State GEAR UP grant, or States that have an active State GEAR UP grant that is scheduled to end prior to October 1, 2024, are eligible to receive a new State GEAR UP award in this competition. States with grants remaining open beyond October 1, 2024, for a no-cost extension period or for the sole purpose of data collection and analysis activities are not considered active for purposes of implementing this directive.

2. a. *Cost Sharing or Matching:* Section 404C(b)(1) of the HEA (20 U.S.C. 1070a–23(b)(1)) requires grantees under this program to provide from State, local, institutional, or private funds, not less than 50 percent of the cost of the program (or one dollar of non-Federal funds for every one dollar of Federal funds awarded), which may be provided in cash or in-kind. The provision also specifies that the match may be accrued over the full duration of the grant award period, except that the

grantee must make substantial progress toward meeting the matching requirement in each year of the grant award period.

Section 404C(c) of the HEA (20 U.S.C. 1070a–23(c)) provides that in-kind contributions may include (1) the amount of the financial assistance obligated under GEAR UP to students from State, local, institutional, or private funds, (2) the amount of tuition, fees, room or board waived or reduced for recipients of financial assistance under GEAR UP, (3) the amount expended on documented, targeted, long-term mentoring and counseling provided by volunteers or paid staff of non-school organizations, including businesses, religious organizations, community groups, postsecondary educational institutions, nonprofit and philanthropic organizations, and other organizations, and (4) equipment and supplies, cash contributions from non-Federal sources, transportation expenses, in-kind or discounted program services, indirect costs, and facility usage.

Grantees must include a budget detailing the source of the matching funds and must provide an outline of the types of matching contributions for at least the first year of the grant in their grant applications. Consistent with 2 CFR 200.306(b), any matching funds must be an allowable use of funds consistent with the GEAR UP program requirements and the Cost Principles described in 2 CFR part 200 subpart E of the Uniform Guidance, and not included as a contribution for any other Federal award.

b. *Supplement-Not-Supplant:* This competition involves supplement, not supplant funding requirements. Under section 404B(e) of the HEA (20 U.S.C. 1070a–22(e)), grant funds awarded under this program must be used to supplement, and not supplant, other Federal, State, and local funds that would otherwise be expended to carry out activities assisted under this program.

c. *Indirect Cost Rate Information:* For entities eligible to apply to this competition, the program regulations at 34 CFR 694.11 limit indirect cost reimbursement to the rate determined in the entity's negotiated indirect cost rate agreement, or 8 percent of a modified total direct cost base, whichever amount is less. For more information regarding indirect costs, or to obtain a negotiated indirect cost rate, please see www2.ed.gov/about/offices/list/ocfo/intro.html.

d. *Administrative Cost Limitation:* This program does not include any program-specific limitation on

administrative expenses. All administrative expenses must be reasonable and necessary and conform to Cost Principles described in 2 CFR part 200 subpart E of the Uniform Guidance.

3. *Subgrantees:* Under 34 CFR 75.708(b) and (c), a grantee under this competition may award subgrants to the following types of entities: Local Educational Agencies (LEAs), State Educational Agencies (SEAs), IHEs, and nonprofit organizations. The grantee may only award subgrants to entities it has identified in an approved application. Under 34 CFR 75.708(d), grantees must ensure that (1) subgrants are awarded on the basis of an approved budget that is consistent with the grantee's approved application and all applicable Federal statutory, regulatory, and other requirements; (2) every subgrant includes any conditions required by Federal statute and executive orders and their implementing regulations; and (3) subgrantees are aware of requirements imposed upon them by Federal statute and regulation, including the Federal anti-discrimination laws enforced by the Department.

4. *Other—General Application Requirements:* All applicants must meet the following application requirements in order to be considered for funding. The application requirements are from sections 404C(a) and 404E of the HEA (20 U.S.C. 1070a–23(a); 20 U.S.C. 1070a–25).

In order for an eligible entity to qualify for a grant under the GEAR UP program, the eligible entity must submit to the Secretary an application for carrying out a GEAR UP program that—

(a) Describes the activities for which assistance under this program is sought, including how the eligible entity will carry out the required activities described in section 404D(a) of the HEA;

(b) Describes, in the case of an eligible entity described in section 404A(c)(1) of the HEA, how the eligible entity will meet the requirements of section 404E of the HEA;

(c) Provides assurances that adequate administrative and support staff will be responsible for coordinating the activities described in section 404D of the HEA;

(d) Provides assurances that activities assisted under this program will not displace an employee or eliminate a position at a school assisted under this program, including a partial displacement such as a reduction in hours, wages, or employment benefits;

(e) Describes, in the case of an eligible entity described in section 404A(c)(1) of the HEA that chooses to use a cohort

approach, how the eligible entity will define the cohorts of the students served by the eligible entity pursuant to section 404B(d) of the HEA, and how the eligible entity will serve the cohorts through grade 12, including—

(i) How vacancies in the program will be filled; and

(ii) How the eligible entity will serve students attending different secondary schools;

(f) Describes how the eligible entity will coordinate programs under this program with other existing Federal, State, or local programs to avoid duplication and maximize the number of students served;

(g) Provides such additional assurances as the Secretary determines necessary to ensure compliance with the requirements of this program;

(h) Provides information about the activities that will be carried out by the eligible entity to support systemic changes from which future cohorts of students will benefit;

(i) Describes the sources of matching funds that will enable the eligible entity to meet the matching requirement described in section 404C(b); and

(j) Demonstrates, in the case of an eligible entity that is requesting to use more than 50 percent of grant funds on GEAR UP early intervention activities and less than 50 percent of grant funds on scholarships, that the eligible entity has another means or multiple means of providing scholarships that meet the minimum Pell Grant requirements under 20 U.S.C. 1070a–25(d) to students eligible for a GEAR UP scholarship under 20 U.S.C. 1070a–25(g). A State requesting an exception from the requirement that it spend at least 50 percent of its grant dollars on scholarships must provide, in its application, documentation of the other means of providing scholarships to students eligible for a GEAR UP scholarship under 20 U.S.C. 1070a–25(g), such as a comprehensive list of other sources of aid that reduce or eliminate the need for the grantee to provide GEAR UP scholarships to eligible students out of its Federal funding; the projected number of students that the grantee expects to receive aid through those sources (*e.g.*, based on past cohorts, if applicable); and, if any, an estimated number of students eligible for a GEAR UP scholarship that are not expected to receive aid through those other sources.

IV. Application and Submission Information

1. Application Submission

Instructions: Applicants are required to follow the Common Instructions for

Applicants to Department of Education Discretionary Grant Programs, published in the **Federal Register** on December 7, 2022 (87 FR 75045), and available at www.federalregister.gov/d/2022-26554, which contain requirements and information on how to submit an application.

2. *Intergovernmental Review:* This program is subject to Executive Order 12372 and the regulations in 34 CFR part 79. Information about Intergovernmental Review of Federal Programs under Executive Order 12372 is in the application package for this program.

3. *Funding Restrictions:* We specify unallowable costs in subpart E of 2 CFR part 200. We reference regulations outlining funding restrictions in the *Applicable Regulations* section of this notice.

Under HEA section 404E(b)(1) (20 U.S.C. 1070a–25(b)(1)), a State must use not less than 25 percent and not more than 50 percent of the grant funds for GEAR UP project activities described in HEA section 404D,² with the remainder of grant funds spent on scholarships to eligible GEAR UP students described in HEA section 404E. However, HEA section 404E(b)(2) (20 U.S.C. 1070a–25(b)(2)) permits the Secretary to allow a State to use more than 50 percent of grant funds received under this program for GEAR UP project activities described in HEA section 404D if the State demonstrates that it has another means of providing the students eligible for a GEAR UP scholarship as defined under 20 U.S.C. 1070a–25(g) with the financial assistance described in HEA section 404E and describes such means in the State's application.

4. *Recommended Page Limit:* The application narrative is where you, the applicant, address the selection criteria that reviewers use to evaluate your application. We recommend that you (1) limit the application narrative to no more than 65 pages and (2) use the following standards:

- A “page” is 8.5” x 11”, on one side only, with 1” margins at the top, bottom, and both sides.
- Double-space (no more than three lines per vertical inch) all text in the application narrative, excluding titles, headings, footnotes, quotations, references, captions as well as all text in charts, tables, figures, and graphs.
- Use a font that is either 12-point font or larger or no smaller than 10 pitch (characters per inch).

²Excluding the provision of funds for postsecondary scholarships required by HEA section 404D(a)(4).

- Use one of the following fonts: Times New Roman, Courier, Courier New, or Arial.

The recommended page limit does not apply to the cover sheet; the budget section, including the narrative budget justification; the assurances and certifications; a scholarship waiver justification; or the one-page abstract. However, the recommended page limit does apply to all of the application narrative.

We recommend that any application addressing the competitive preference priorities include no more than three additional pages for each priority addressed.

V. Application Review Information

1. *Selection Criteria:* The selection criteria for this competition are from 34 CFR 75.210.

(a) *Need for project.* (up to 10 points)
(1) The Secretary considers the need for the proposed project.

(2) In determining the need for the proposed project, the Secretary considers:

(i) The magnitude or severity of the problem to be addressed by the proposed project (up to 4 points);

(ii) The extent to which the proposed project will provide services or otherwise address the needs of students at risk of educational failure (up to 3 points); and

(iii) The extent to which the proposed project will focus on serving or otherwise addressing the needs of disadvantaged individuals (up to 3 points).

(b) *Quality of the project design.* (up to 30 points)

(1) The Secretary considers the quality of the design of the proposed project.

(2) In determining the quality of the design of the proposed project, the Secretary considers:

(i) The extent to which the goals, objectives, and outcomes to be achieved by the proposed project are clearly specified and measurable (up to 8 points);

(ii) The extent to which the proposed project demonstrates a rationale (as defined in this notice) (up to 7 points);

(iii) The extent to which the proposed project represents an exceptional approach for meeting statutory purposes and requirements (up to 8 points); and

(iv) How the applicant will ensure that a diversity of perspectives are brought to bear in the operation of the proposed project, including those of parents, teachers, the business community, a variety of disciplinary and professional fields, recipients or beneficiaries of services, or others, as appropriate (up to 7 points).

(c) *Adequacy of resources.* (up to 15 points)

(1) The Secretary considers the adequacy of resources for the proposed project.

(2) In determining the adequacy of resources for the proposed project, the Secretary considers:

(i) The adequacy of support, including facilities, equipment, supplies, and other resources, from the applicant organization or the lead applicant organization and the relevance and demonstrated commitment of each partner in the proposed project to the implementation and success of the project (up to 5 points);

(ii) The extent to which the costs are reasonable in relation to the number of persons to be served and to the anticipated results and benefits (up to 5 points); and

(iii) The potential for continued support of the project after Federal funding ends, including, as appropriate, the demonstrated commitment of appropriate entities to such support (up to 5 points).

(d) *Quality of project personnel.* (up to 20 points)

(1) The Secretary considers the quality of the personnel who will carry out the proposed project.

(2) In determining the quality of project personnel, the Secretary considers the extent to which the applicant encourages applications for employment from persons who are members of groups that have traditionally been underrepresented based on race, color, national origin, gender, age, or disability (up to 5 points).

(3) In addition, the Secretary considers:

(i) The qualifications, including relevant training and experience, of the project director or principal investigator (up to 5 points);

(ii) The qualifications, including relevant training and experience, of key project personnel (up to 5 points); and

(iii) The extent to which the time commitments of the project director and principal investigator and other key project personnel are appropriate and adequate to meet the objectives of the proposed project (up to 5 points).

(e) *Quality of the project evaluation.* (up to 25 points)

(1) The Secretary considers the quality of the evaluation to be conducted of the proposed project.

(2) In determining the quality of the project evaluation, the Secretary considers:

(i) The extent to which the methods of evaluation include the use of objective performance measures that are

clearly related to the intended outcomes of the project and will produce quantitative and qualitative data to the extent possible (up to 10 points);

(ii) The extent to which the methods of evaluation will provide performance feedback and permit periodic assessment of progress toward achieving intended outcomes (up to 10 points); and

(iii) The extent to which the methods of evaluation will, if well implemented, produce promising evidence (as defined in this notice) about the project's effectiveness. (up to 5 points).

Note: For purposes of the quality of the project evaluation, selection factor (iii), applicants can propose to evaluate a specific project component to build promising evidence of effectiveness about that strategy. Importantly, the project component that is the focus of evaluation selection factor (iii) does not need to be the same component for which evidence is provided in Competitive Preference Priority 4 or in the project design selection criteria.

2. Review and Selection Process: We remind potential applicants that in reviewing applications in any discretionary grant competition, the Secretary may consider, under 34 CFR 75.217(d)(3), the past performance of the applicant in carrying out a previous award, such as the applicant's use of funds, achievement of project objectives, and compliance with grant conditions. The Secretary may also consider whether the applicant failed to submit a timely performance report or submitted a report of unacceptable quality.

In addition, in making a competitive grant award, the Secretary requires various assurances including those applicable to Federal civil rights laws that prohibit discrimination in programs or activities receiving Federal financial assistance from the Department (34 CFR 100.4, 104.5, 106.4, 108.8, and 110.23).

As required by 20 U.S.C. 1070a-23(d), a panel of non-Federal reviewers will review each application for this competition in accordance with the procedures described in 34 CFR 75.217. The individual scores of the reviewers will be added and the sum divided by the number of reviewers to determine the peer review score received in the review process.

If there are insufficient funds for all applications with the same total scores, the Secretary will select among tied applications according to the following procedures. The first tiebreaker criterion will be to select for funding the tied applicant(s) representing the State(s) that has gone longest since being funded under the GEAR UP State program. If

still tied, the second tiebreaker will be to fund, from the States still tied after implementing the first tiebreaker, the States with the highest percentage of individuals living in poverty based on Small Area Income and Poverty Estimates Program (SAIPE) data (age range 5-17) or decennial census data, as appropriate.

3. Risk Assessment and Specific Conditions: Consistent with 2 CFR 200.206, before awarding grants under this competition the Department conducts a review of the risks posed by applicants. Under 2 CFR 200.208, the Secretary may impose specific conditions and, under 2 CFR 3474.10, in appropriate circumstances, high-risk conditions on a grant if the applicant or grantee is not financially stable; has a history of unsatisfactory performance; has a financial or other management system that does not meet the standards in 2 CFR part 200, subpart D; has not fulfilled the conditions of a prior grant; or is otherwise not responsible.

4. Integrity and Performance System: If you are selected under this competition to receive an award that over the course of the project period may exceed the simplified acquisition threshold (currently \$250,000), under 2 CFR 200.206(a)(2) we must make a judgment about your integrity, business ethics, and record of performance under Federal awards—that is, the risk posed by you as an applicant—before we make an award. In doing so, we must consider any information about you that is in the integrity and performance system (currently referred to as the Federal Awardee Performance and Integrity Information System (FAPIIS)), accessible through the System for Award Management. You may review and comment on any information about yourself that a Federal agency previously entered and that is currently in FAPIIS.

Please note that, if the total value of your currently active grants, cooperative agreements, and procurement contracts from the Federal Government exceeds \$10,000,000, the reporting requirements in 2 CFR part 200, appendix XII, require you to report certain integrity information to FAPIIS semiannually. Please review the requirements in 2 CFR part 200, appendix XII, if this grant plus all the other Federal funds you receive exceed \$10,000,000.

5. In General: In accordance with the Uniform Guidance located at 2 CFR part 200, all applicable Federal laws, and relevant Executive guidance, the Department will review and consider applications for funding pursuant to this notice inviting applications in accordance with—

(a) Selecting recipients most likely to be successful in delivering results based on the program objectives through an objective process of evaluating Federal award applications (2 CFR 200.205);

(b) Prohibiting the purchase of certain telecommunication and video surveillance services or equipment in alignment with section 889 of the National Defense Authorization Act of 2019 (Pub. L. 115—232) (2 CFR 200.216);

(c) Providing a preference, to the extent permitted by law, to maximize use of goods, products, and materials produced in the United States (2 CFR 200.322); and

(d) Terminating agreements in whole or in part to the greatest extent authorized by law if an award no longer effectuates the program goals or agency priorities (2 CFR 200.340).

VI. Award Administration Information

1. *Award Notices:* If your application is successful, we notify your U.S. Representative and U.S. Senators and send you a Grant Award Notification (GAN), or we may send you an email containing a link to access an electronic version of your GAN. We may notify you informally, also.

If your application is not evaluated or not selected for funding, we will notify you.

2. *Administrative and National Policy Requirements:* We identify administrative and national policy requirements in the application package and reference these and other requirements in the *Applicable Regulations* section of this notice.

We reference the regulations outlining the terms and conditions of an award in the *Applicable Regulations* section of this notice and include these and other specific conditions in the GAN. The GAN also incorporates your approved application as part of your binding commitments under the grant.

3. *Open Licensing Requirements:* Unless an exception applies, if you are awarded a grant under this competition, you will be required to openly license to the public grant deliverables created in whole, or in part, with Department grant funds. When the deliverable consists of modifications to pre-existing works, the license extends only to those modifications that can be separately identified and only to the extent that open licensing is permitted under the terms of any licenses or other legal restrictions on the use of pre-existing works. Additionally, a grantee or subgrantee that is awarded competitive grant funds must have a plan to disseminate these public grant deliverables. This dissemination plan

can be developed and submitted after your application has been reviewed and selected for funding. For additional information on the open licensing requirements please refer to 2 CFR 3474.20.

4. *Reporting:* (a) If you apply for a grant under this competition, you must ensure that you have in place the necessary processes and systems to comply with the reporting requirements in 2 CFR part 170 should you receive funding under the competition. This does not apply if you have an exception under 2 CFR 170.110(b).

(b) At the end of your project period, you must submit a final performance report, including financial information, as directed by the Secretary. If you receive a multiyear award, you must submit an annual performance report that provides the most current performance and financial expenditure information as directed by the Secretary under 34 CFR 75.118. The Secretary may also require more frequent performance reports under 34 CFR 75.720(c). For specific requirements on reporting, please go to www.ed.gov/fund/grant/apply/appforms/appforms.html.

(c) Under 34 CFR 75.250(b), the Secretary may provide a grantee with additional funding for data collection analysis and reporting. In this case, the Secretary establishes a data collection period.

5. *Performance Measures:* The performance measures for the GEAR UP Program are established for purposes of Department reporting under 34 CFR 75.110. The objectives of the GEAR UP program are (1) to increase the academic performance and preparation for postsecondary education of participating students; (2) to increase the rate of high school graduation and participation in postsecondary education of participating students; and (3) to increase education expectations for participating students and increase student and family knowledge of postsecondary education options, preparation, and financing.

The effectiveness of this program depends on the rate at which program participants complete high school and enroll in and complete a postsecondary education. We developed the following performance measures to track progress toward achieving the program's goals:

1. The percentage of GEAR UP students who pass Algebra 1 or its equivalent by the end of ninth grade.

2. The percentage of GEAR UP students who graduate from high school.

3. The percentage of GEAR UP students who complete the Free Application for Federal Student Aid.

4. The percentage of GEAR UP students and former GEAR UP students who are enrolled at an IHE.

5. The percentage of current GEAR UP students and former GEAR UP students who enrolled at an IHE and persisted to the second year of postsecondary education at the initial or a subsequent IHE.

In addition, to assess the efficiency of the program, we track the average cost, in Federal funds, of achieving a successful outcome, where success is defined as enrollment in a program of undergraduate instruction at an IHE of GEAR UP students immediately after high school graduation. These performance measures constitute GEAR UP's indicators of the success of the program. Accordingly, we require that applicants include these performance measures in conceptualizing the design, implementation, and evaluation of their proposed projects.

6. *Continuation Awards:* In making a continuation award under 34 CFR 75.253, the Secretary considers, among other things, whether a grantee has made substantial progress in achieving the goals and objectives of the project; whether the grantee has expended funds in a manner that is consistent with its approved application and budget; and, if the Secretary has established performance measurement requirements, whether the grantee has made substantial progress in achieving the performance targets in the grantee's approved application.

In making a continuation award, the Secretary also considers whether the grantee is operating in compliance with the assurances in its approved application, including those applicable to Federal civil rights laws that prohibit discrimination in programs or activities receiving Federal financial assistance from the Department (34 CFR 100.4, 104.5, 106.4, 108.8, and 110.23).

VII. Other Information

Accessible Format: On request to the program contact person listed under **FOR FURTHER INFORMATION CONTACT**, individuals with disabilities can obtain this document and a copy of the application package in an accessible format. The Department will provide the requestor with an accessible format that may include Rich Text Format (RTF) or text format (txt), a thumb drive, an MP3 file, braille, large print, audiotape, or compact disc, or other accessible format.

Electronic Access to This Document: The official version of this document is the document published in the **Federal**

Register. You may access the official edition of the **Federal Register** and the Code of Federal Regulations at www.govinfo.gov. At this site you can view this document, as well as all other documents of this Department published in the **Federal Register**, in text or Portable Document Format (PDF). To use PDF you must have Adobe Acrobat Reader, which is available free at the site.

You may also access documents of the Department published in the **Federal Register** by using the article search feature at www.federalregister.gov. Specifically, through the advanced search feature at this site, you can limit your search to documents published by the Department.

Nasser H. Paydar,

Assistant Secretary for Postsecondary Education.

[FR Doc. 2024-04914 Filed 3-7-24; 8:45 am]

BILLING CODE 4000-01-P

DEPARTMENT OF EDUCATION

[Docket No.: ED-2024-SCC-0043]

Agency Information Collection Activities; Submission to the Office of Management and Budget for Review and Approval; Comment Request; Application for Grants Under the Educational Opportunity Centers Program (1894-0001)

AGENCY: Office of Postsecondary Education (OPE), Department of Education (ED).

ACTION: Notice.

SUMMARY: In accordance with the Paperwork Reduction Act (PRA) of 1995, the Department is proposing a reinstatement without change of a currently approved information collection request (ICR).

DATES: Interested persons are invited to submit comments on or before April 8, 2024.

ADDRESSES: Written comments and recommendations for proposed information collection requests should be submitted within 30 days of publication of this notice. Click on this link www.reginfo.gov/public/do/PRAMain to access the site. Find this information collection request (ICR) by selecting "Department of Education" under "Currently Under Review," then check the "Only Show ICR for Public Comment" checkbox. *Reginfo.gov* provides two links to view documents related to this information collection request. Information collection forms and instructions may be found by clicking on the "View Information

Collection (IC) List" link. Supporting statements and other supporting documentation may be found by clicking on the "View Supporting Statement and Other Documents" link.

FOR FURTHER INFORMATION CONTACT: For specific questions related to collection activities, please contact Rachael Wiley, (202) 987-0396.

SUPPLEMENTARY INFORMATION: The Department is especially interested in public comment addressing the following issues: (1) is this collection necessary to the proper functions of the Department; (2) will this information be processed and used in a timely manner; (3) is the estimate of burden accurate; (4) how might the Department enhance the quality, utility, and clarity of the information to be collected; and (5) how might the Department minimize the burden of this collection on the respondents, including through the use of information technology. Please note that written comments received in response to this notice will be considered public records.

Title of Collection: Application for Grants under the Educational Opportunity Centers Program (1894-0001).

OMB Control Number: 1840-0820.

Type of Review: Reinstatement without change of a currently approved ICR.

Respondents/Affected Public: Private Sector; State, Local, and Tribal Governments.

Total Estimated Number of Annual Responses: 610.

Total Estimated Number of Annual Burden Hours: 15,020.

Abstract: The Department of Education is requesting a reinstatement without change of the application for grants under the Educational Opportunity Centers (EOC) Program because the previous EOC application was discontinued, and the application will be needed for a Fiscal Year (FY) 2026 competition for new awards. The Department expects the same number of respondents for the FY 2026 competition for new awards. The FY 2026 application will incorporate new competitive preference priorities.

This collection is being submitted under the Streamlined Clearance Process for Discretionary Grant Information Collections (1894-0001). Therefore, the 30-day public comment period notice will be the only public comment notice published for this information collection.

Dated: March 5, 2024.

Kun Mullan,

PRA Coordinator, Strategic Collections and Clearance, Governance and Strategy Division, Office of Chief Data Officer, Office of Planning, Evaluation and Policy Development.

[FR Doc. 2024-04959 Filed 3-7-24; 8:45 am]

BILLING CODE 4000-01-P

DEPARTMENT OF EDUCATION

Applications for New Awards; Gaining Early Awareness and Readiness for Undergraduate Programs (Partnership Grants)

AGENCY: Office of Postsecondary Education, Department of Education.

ACTION: Notice.

SUMMARY: The Department of Education (Department) is issuing a notice inviting applications for new awards for fiscal year (FY) 2024 for the Gaining Early Awareness and Readiness for Undergraduate Programs (GEAR UP) Partnership Grants, Assistance Listing Number 84.334A. This notice relates to the approved information collection under OMB control number 1840-0821.

DATES:

Applications Available: March 8, 2024.

Deadline for Transmittal of Applications: May 7, 2024.

Deadline for Intergovernmental Review: July 8, 2024.

ADDRESSES: For the addresses for obtaining and submitting an application, please refer to our Common Instructions for Applicants to Department of Education Discretionary Grant Programs, published in the **Federal Register** on December 7, 2022 (87 FR 75045) and available at www.federalregister.gov/d/2022-26554.

FOR FURTHER INFORMATION CONTACT: Ben Witthoefft, U.S. Department of Education, 5th floor, 400 Maryland Avenue SW, Washington, DC 20202-6450. Telephone: (202) 453-7576. Email: Ben.Witthoefft@ed.gov.

If you are deaf, hard of hearing, or have a speech disability and wish to access telecommunications relay services, please dial 7-1-1.

SUPPLEMENTARY INFORMATION:

Full Text of Announcement

I. Funding Opportunity Description

Purpose of Program: The GEAR UP program is a discretionary grant program that encourages eligible entities to provide support, and maintain a commitment, to eligible students from low-income backgrounds, including students with disabilities, to assist the

students in obtaining a secondary school diploma (or its recognized equivalent) and to prepare for and succeed in postsecondary education. Under the GEAR UP program, the Department awards grants to two types of entities: (1) States and (2) Partnerships consisting of at least one degree-granting institution of higher education (IHE) and at least one local educational agency (LEA).

Background: In this notice, the Department invites applications for Partnership grants only. We will invite applications for State grants in another notice published in the **Federal Register**. Required services under the GEAR UP program are specified in section 404D(a) of the Higher Education Act of 1965, as amended (HEA) (20 U.S.C. 1070a–24(a)), and permissible services under the GEAR UP program are specified in section 404D(b) of the HEA (20 U.S.C. 1070a–24(b)). For Partnership grantees, activities must include providing financial aid information for postsecondary education, encouraging enrollment in rigorous and challenging coursework in order to reduce the need for remediation at the postsecondary education level, and implementing activities to improve the number of participating students who obtain a secondary school diploma and who complete applications for and enroll in a program of postsecondary education. Activities may also include mentoring; tutoring; supporting dual or concurrent enrollment programs; providing special programs or tutoring in science, technology, engineering, or mathematics (STEM); academic and career counseling; financial and economic literacy education; and exposure to college campuses.

Priorities: This notice contains three competitive preference priorities. Competitive Preference Priorities 1 and 2 are from the Secretary's Final Supplemental Priorities and Definitions for Discretionary Grant Programs published in the **Federal Register** on December 10, 2021 (86 FR 70612) (Supplemental Priorities). Competitive Preference Priority 3 is from 34 CFR 75.226(d).

Competitive Preference Priorities: For FY 2024 and any subsequent year in which we make awards from the list of unfunded applications from this competition, these priorities are competitive preference priorities. Under 34 CFR 75.105(c)(2)(i), we award up to an additional 13 points to an application depending on how well the application meets the competitive preference priorities.

These priorities are:

Competitive Preference Priority 1—Increasing Postsecondary Education Access, Affordability, Completion, and Post-Enrollment Success (up to 5 points).

Projects that are designed to increase postsecondary access, affordability, completion, and success for underserved students by establishing a system of high-quality data collection and analysis, such as data on persistence, retention, completion, and post-college outcomes, for transparency, accountability, and institutional improvement.

Competitive Preference Priority 2—Meeting Student Social, Emotional, and Academic Needs (up to 5 points).

Projects that are designed to improve students' social, emotional, academic, and career development, with a focus on underserved students, through creating education or work-based settings that are supportive, positive, identity-safe and inclusive with regard to race, ethnicity, culture, language, and disability status, through developing trusting relationships between students (including underserved students), educators, families, and community partners.

Competitive Preference Priority 3—Moderate Evidence (3 points).

Applications supported by evidence that meets the conditions in the definition of "moderate evidence" (as defined in this notice).

Note: To address the priority, an applicant may submit up to two study citations that it believes supports the implementation of a GEAR UP authorized activity proposed in the application and that meet the moderate evidence standard. For Partnership grantees, required GEAR UP services are specified in section 404D(a) of the HEA (20 U.S.C. 1070a–24(a)), and permissible services are specified in section 404D(b) of the HEA (20 U.S.C. 1070a–24(b)). Applicants can cite What Works Clearinghouse (WWC) intervention reports, WWC practice guides, or individual studies—both those already listed in the Department's WWC Database of Individual Studies¹ and those that have not yet been reviewed by the WWC.

The proposed studies must be cited in the section of the application that addresses Competitive Preference Priority 3 as well as on the Evidence Form. Applicants should also describe (1) the project component(s) from the cited research they intend to implement in their GEAR UP project, (2) the relevant outcome(s) that are included in both the study (or WWC practice guide

or intervention report) and in the proposed project, (3) the research findings suggesting a favorable relationship between the project component and the relevant outcome, and (4) how the population and/or settings in the cited research overlap with that of the proposed project. The Department will review the research cited by the applicant to determine if it meets the requirements for moderate evidence, as well as whether it is sufficiently aligned with the project proposed.

Definitions: The definitions of "demonstrates a rationale," "experimental study," "logic model," "moderate evidence," "project component," "promising evidence," "quasi-experimental design study," "relevant outcome," and "What Works Clearinghouse (WWC) Handbooks (WWC Handbooks)" are from 34 CFR 77.1(c). The definitions of "children or students with disabilities," "disconnected youth," "English learner," and "underserved students" are from the Supplemental Priorities.

Demonstrates a rationale means a key project component included in the project's logic model is informed by research or evaluation findings that suggest the project component is likely to improve relevant outcomes.

Experimental study means a study that is designed to compare outcomes between two groups of individuals (such as students) that are otherwise equivalent except for their assignment to either a treatment group receiving a project component or a control group that does not. Randomized controlled trials, regression discontinuity design studies, and single-case design studies are the specific types of experimental studies that, depending on their design and implementation (e.g., sample attrition in randomized controlled trials and regression discontinuity design studies), can meet What Works Clearinghouse (WWC) standards without reservations as described in the WWC Handbooks:

(i) A randomized controlled trial employs random assignment of, for example, students, teachers, classrooms, or schools to receive the project component being evaluated (the treatment group) or not to receive the project component (the control group).

(ii) A regression discontinuity design study assigns the project component being evaluated using a measured variable (e.g., assigning students reading below a cutoff score to tutoring or developmental education classes) and controls for that variable in the analysis of outcomes.

¹ <https://ies.ed.gov/ncee/wwc/ReviewedStudies#>.

(iii) A single-case design study uses observations of a single case (*e.g.*, a student eligible for a behavioral intervention) over time in the absence and presence of a controlled treatment manipulation to determine whether the outcome is systematically related to the treatment.

Logic model (also referred to as a theory of action) means a framework that identifies key project components of the proposed project (*i.e.*, the active “ingredients” that are hypothesized to be critical to achieving the relevant outcomes) and describes the theoretical and operational relationships among the key project components and relevant outcomes.

Note: In developing logic models, applicants may want to use resources such as the Regional Educational Laboratory Program’s (REL Pacific) Education Logic Model Application, available at <https://ies.ed.gov/ncee/edlabs/regions/pacific/elm.asp>, to help design their logic models. Other sources include: https://ies.ed.gov/ncee/edlabs/regions/pacific/pdf/REL_2014025.pdf, https://ies.ed.gov/ncee/edlabs/regions/pacific/pdf/REL_2014007.pdf, and https://ies.ed.gov/ncee/edlabs/regions/northeast/pdf/REL_2015057.pdf.

Moderate evidence means that there is evidence of effectiveness of a key project component in improving a relevant outcome for a sample that overlaps with the populations or settings proposed to receive that component, based on a relevant finding from one of the following:

(i) A practice guide prepared by the WWC using version 2.1, 3.0, 4.0, or 4.1 of the WWC Handbooks reporting a “strong evidence base” or “moderate evidence base” for the corresponding practice guide recommendation;

(ii) An intervention report prepared by the WWC using version 2.1, 3.0, 4.0, or 4.1 of the WWC Handbooks reporting a “positive effect” or “potentially positive effect” on a relevant outcome based on a “medium to large” extent of evidence, with no reporting of a “negative effect” or “potentially negative effect” on a relevant outcome; or

(iii) A single experimental study or quasi-experimental design study reviewed and reported by the WWC using version 2.1, 3.0, 4.0, or 4.1 of the WWC Handbooks, or otherwise assessed by the Department using version 4.1 of the WWC Handbooks, as appropriate, and that—

(A) Meets WWC standards with or without reservations;

(B) Includes at least one statistically significant and positive (*i.e.*, favorable) effect on a relevant outcome;

(C) Includes no overriding statistically significant and negative effects on relevant outcomes reported in the study or in a corresponding WWC intervention report prepared under version 2.1, 3.0, 4.0, or 4.1 of the WWC Handbooks; and

(D) Is based on a sample from more than one site (*e.g.*, State, county, city, school district, or postsecondary campus) and includes at least 350 students or other individuals across sites. Multiple studies of the same project component that each meet requirements in paragraphs (iii)(A), (B), and (C) of this definition may together satisfy the requirement in this paragraph (iii)(D).

Note: The WWC Procedures and Standards Handbook (Version 4.1), as well as the more recent WWC Handbook released in August 2022 (Version 5.0), are available at <https://ies.ed.gov/ncee/wwc/Handbooks>.

Project component means an activity, strategy, intervention, process, product, practice, or policy included in a project. Evidence may pertain to an individual project component or to a combination of project components (*e.g.*, training teachers on instructional practices for English learners and follow-on coaching for these teachers).

Promising evidence means that there is evidence of the effectiveness of a key project component in improving a relevant outcome, based on a relevant finding from one of the following:

(i) A practice guide prepared by WWC reporting a “strong evidence base” or “moderate evidence base” for the corresponding practice guide recommendation;

(ii) An intervention report prepared by the WWC reporting a “positive effect” or “potentially positive effect” on a relevant outcome with no reporting of a “negative effect” or “potentially negative effect” on a relevant outcome; or

(iii) A single study assessed by the Department, as appropriate, that—

(A) Is an experimental study, a quasi-experimental design study, or a well-designed and well-implemented correlational study with statistical controls for selection bias (*e.g.*, a study using regression methods to account for differences between a treatment group and a comparison group); and

(B) Includes at least one statistically significant and positive (*i.e.*, favorable) effect on a relevant outcome.

Quasi-experimental design study means a study using a design that attempts to approximate an experimental study by identifying a comparison group that is similar to the treatment group in important respects.

This type of study, depending on design and implementation (*e.g.*, establishment of baseline equivalence of the groups being compared), can meet WWC standards with reservations, as described in the WWC Handbooks.

Relevant outcome means the student outcome(s) or other outcome(s) the key project component is designed to improve, consistent with the specific goals of the program.

Underserved student means a student in postsecondary education in one or more of the following subgroups:

(a) A student who is living in poverty or is served by schools with high concentrations of students living in poverty.

(b) A student of color.

(c) A student who is a member of a federally recognized Indian Tribe.

(d) An English learner.

(e) A child or student with a disability.

(f) A disconnected youth.

(g) A migrant student.

(h) A student experiencing homelessness or housing insecurity.

(i) A lesbian, gay, bisexual, transgender, queer or questioning, or intersex (LGBTQI+) student.

(j) A student who is in foster care.

(k) A pregnant, parenting, or caregiving student.

(l) A student who is the first in their family to attend postsecondary education.

(m) A student who is enrolled in or is seeking to enroll in postsecondary education who is eligible for a Pell Grant.

For purposes of the definition of *underserved student* only—

Children or students with disabilities means children with disabilities as defined in section 602(3) of the Individuals with Disabilities Education Act (IDEA) (20 U.S.C. 1401(3)) and 34 CFR 300.8, or students with disabilities, as defined in the Rehabilitation Act of 1973 (29 U.S.C. 705(37), 705(202) (B));

Disconnected youth means an individual, between the ages 14 and 24, who may be from a low-income background, experiences homelessness, is in foster care, is involved in the justice system, or is not working or not enrolled in (or at risk of dropping out of) an educational institution; and

English learner means an individual who is an English learner as defined in section 8101(20) of the Elementary and Secondary Education Act of 1965, as amended, or an individual who is an English language learner as defined in section 203(7) of the Workforce Innovation and Opportunity Act.

What Works Clearinghouse (WWC) Handbooks (WWC Handbooks) means

the standards and procedures set forth in the WWC Standards Handbook, Versions 4.0 or 4.1, and WWC Procedures Handbook, Versions 4.0 or 4.1, or in the WWC Procedures and Standards Handbook, Version 3.0 or Version 2.1 (all incorporated by reference, see § 77.2). Study findings eligible for review under WWC standards can meet WWC standards without reservations, meet WWC standards with reservations, or not meet WWC standards. WWC practice guides and intervention reports include findings from systematic reviews of evidence as described in the WWC Handbooks documentation.

Note: The WWC Procedures and Standards Handbook (Version 4.1), as well as the more recent WWC Handbook released in August 2022 (Version 5.0), are available at <https://ies.ed.gov/ncee/wwc/Handbooks>.

Program Authority: 20 U.S.C. 1070a–21—1070a–28.

Note: Projects will be awarded and must be operated in a manner consistent with the nondiscrimination requirements contained in Federal civil rights laws.

Applicable Regulations: (a) The Education Department General Administrative Regulations (EDGAR) in 34 CFR parts 75, 77, 79, 81, 82, 84, 86, 97, 98, and 99. (b) The Office of Management and Budget Guidelines to Agencies on Governmentwide Debarment and Suspension (Nonprocurement) in 2 CFR part 180, as adopted and amended as regulations of the Department in 2 CFR part 3485. (c) The Uniform Administrative Requirements, Cost Principles, and Audit Requirements for Federal Awards in 2 CFR part 200, as adopted and amended as regulations of the Department in 2 CFR part 3474. (d) The regulations for this program in 34 CFR part 694. (e) The Supplemental Priorities.

Note: The regulations in 34 CFR part 86 apply to IHEs only.

II. Award Information

Type of Award: Discretionary grants.

Estimated Available Funds: The Administration has requested \$408,000,000 for GEAR UP for FY 2024, of which we intend to use an estimated \$40,000,000 for the Partnership competition. The actual level of funding, if any, depends on final congressional action. However, we are inviting applications to allow enough time to complete the grant process if Congress appropriates funds for this program.

Contingent upon the availability of funds and the quality of applications,

we may make additional awards in subsequent years from the list of unfunded applications from this competition.

Estimated Range of Awards:

\$100,000–\$5,000,000.

Estimated Average Size of Awards:

\$1,200,000.

Maximum Award: We will not fund any application for a Partnership grant above the maximum award of \$800 per student for a single budget period of 12 months. Additionally, no funding will be awarded for increases in years two through seven.

Estimated Number of Awards: 34.

Note: The Department is not bound by any estimates in this notice.

Project Period: Either 72 months or 84 months.

Note: An applicant that wishes to seek funding for a seventh project year (*i.e.*, for a project period greater than 72 months), in order to provide project services to GEAR UP students through their first year of attendance at an IHE, must propose to do so in its application.

III. Eligibility Information

1. *Eligible Applicants:* Partnerships consisting of (a) at least one degree-granting IHE and (b) at least one LEA. Partnerships may include not less than two other community organizations or entities, such as businesses, professional organizations, State agencies, institutions or agencies sponsoring programs authorized under the Leveraging Educational Assistance Partnership Program authorized in part A, subpart 4, of title IV of the HEA (20 U.S.C. 1070c *et seq.*), or other public or private agencies or organizations (20 U.S.C. 1070a–21(c)(2)).

Note: A Partnership under this competition must follow the procedures under 34 CFR 75.127–75.129 in developing a group application. This includes developing an agreement that details the activities that each member of the group plans to perform and binds each member of the group to every statement and assurance made by the applicant in the application. This agreement must be submitted with the application.

Note: If you are a nonprofit organization, under 34 CFR 75.51, you may demonstrate your nonprofit status by providing: (1) proof that the Internal Revenue Service currently recognizes the applicant as an organization to which contributions are tax deductible under section 501(c)(3) of the Internal Revenue Code; (2) a statement from a State taxing body or the State attorney general certifying that the organization is a nonprofit organization operating within the State and that no part of its

net earnings may lawfully benefit any private shareholder or individual; (3) a certified copy of the applicant's certificate of incorporation or similar document if it clearly establishes the nonprofit status of the applicant; or (4) any item described above if that item applies to a State or national parent organization, together with a statement by the State or parent organization that the applicant is a local nonprofit affiliate.

2. a. *Cost Sharing or Matching:*

Section 404C(b)(1) of the HEA requires grantees under this program to provide from State, local, institutional, or private funds, not less than 50 percent of the cost of the program (or one dollar of non-Federal funds for every one dollar of Federal funds awarded), which may be provided in cash or in-kind. The provision also specifies that the match may be accrued over the full duration of the grant award period, except that the grantee must make substantial progress towards meeting the matching requirement in each year of the grant award period.

Section 404C(c) of the HEA provides that in-kind contributions may include (1) the amount of the financial assistance obligated under GEAR UP to students from State, local, institutional, or private funds, (2) the amount of tuition, fees, room or board waived or reduced for recipients of financial assistance under GEAR UP, (3) the amount expended on documented, targeted, long-term mentoring and counseling provided by volunteers or paid staff of non-school organizations, including businesses, religious organizations, community groups, postsecondary educational institutions, nonprofit and philanthropic organizations, and other organizations, and (4) equipment and supplies, cash contributions from non-Federal sources, transportation expenses, in-kind or discounted program services, indirect costs, and facility usage.

Section 404C(b)(2) further provides that the Secretary may approve a Partnership's request for a reduced match percentage at the time of application if the Partnership demonstrates significant economic hardship that precludes the Partnership from meeting the matching requirement, or if the Partnership requests that contributions to the scholarship fund, if applicable, be matched on the basis of two non-Federal dollars for every one Federal dollar of GEAR UP funds. GEAR UP program regulations in 34 CFR 694.8(a)–(c) address the content of an applicant's request for such a reduced match, and the maximum percentage match that the Secretary may waive. In

addition, the Secretary may approve a reduction in match of up to 70 percent upon request from a Partnership that (a) includes three or fewer IHEs as members (b) has a fiscal agent identified in 34 CFR 694.8(d)(1), and (c) serves students in schools and LEAs that meet the poverty criteria identified in 34 CFR 694.8(d)(2) and (3).

Given the importance of matching funds to the long-term success of the project, eligible entities must describe how they will meet the matching requirement and sources of matching funds, as required by *General Application Requirements* (b) and (j).

Grantees must include a budget detailing the source of the matching funds and must provide an outline of the types of matching contributions for at least the first year of the grant in their grant applications. Consistent with 2 CFR 200.306(b), any matching funds must be an allowable use of funds consistent with the GEAR UP program requirements and the cost principles detailed in subpart E of 2 CFR part 200, and not included as a contribution for any other Federal award.

b. *Supplement-Not-Supplant*: This competition involves supplement, not supplant funding requirements. Under section 404B(e) of the HEA (20 U.S.C. 1070a-22(e)), grant funds awarded under this program must be used to supplement, and not supplant, other Federal, State, and local funds that would otherwise be expended to carry out activities assisted under this program.

c. *Indirect Cost Rate Information*: For projects that designate an LEA as the fiscal agent, the GEAR UP program regulations at 34 CFR 694.11 limit indirect cost reimbursement to the restricted rate established by the LEA's negotiated indirect cost rate agreement or eight percent of a modified total direct cost base, whichever amount is less. For projects that designate an IHE as the fiscal agent, the GEAR UP program uses a training indirect cost rate. This rate limits indirect cost reimbursement to an entity's actual indirect costs, as determined in its negotiated indirect cost rate agreement, or eight percent of a modified total direct cost base, whichever amount is less. For more information regarding training indirect cost rates, see 34 CFR 75.562. For more information regarding indirect costs, or to obtain a negotiated indirect cost rate, please see www2.ed.gov/about/offices/list/ocfo/intro.html.

d. *Administrative Cost Limitation*: This program does not include any program-specific limitation on administrative expenses. All

administrative expenses must be reasonable and necessary and conform to Cost Principles described in 2 CFR part 200 subpart E of the Uniform Guidance.

3. *Subgrantees*: A grantee under this competition may not award subgrants to entities to directly carry out project activities described in its application.

4. *Other: General Application Requirements*: All applicants must meet the following application requirements in order to be considered for funding. The application requirements are from section 404C(a) of the HEA (20 U.S.C. 1070a-23(a)).

In order for an eligible entity to qualify for a grant under the GEAR UP program, the eligible entity must submit to the Secretary an application for carrying out a GEAR UP program that—

(a) Describes the activities for which assistance under this program is sought, including how the eligible entity will carry out the required activities described in section 404D(a) of the HEA;

(b) Describes, in the case of an eligible entity described in section 404A(c)(2) of the HEA that chooses to provide scholarships, how the eligible entity will meet the requirements of section 404E of the HEA;

(c) Describes, in the case of an eligible entity described in section 404A(c)(2) of the HEA that requests a reduced match percentage under section 404C(b)(2) of the HEA, how such reduction will assist the entity to provide the scholarships described in section 404C(b)(2)(A)(ii) of the HEA;

(d) Provides assurances that adequate administrative and support staff will be responsible for coordinating the activities described in section 404D of the HEA;

(e) Provides assurances that activities assisted under this program will not displace an employee or eliminate a position at a school assisted under this program, including a partial displacement such as a reduction in hours, wages, or employment benefits;

(f) Describes, in the case of an eligible entity described in section 404A(c)(1) of the HEA that chooses to use a cohort approach, or an eligible entity described in section 404A(c)(2) of the HEA, how the eligible entity will define the cohorts of the students served by the eligible entity pursuant to section 404B(d) of the HEA, and how the eligible entity will serve the cohorts through grade 12, including—

(i) How vacancies in the program will be filled; and

(ii) How the eligible entity will serve students attending different secondary schools;

(g) Describes how the eligible entity will coordinate programs under this program with other existing Federal, State, or local programs to avoid duplication and maximize the number of students served;

(h) Provides such additional assurances as the Secretary determines necessary to ensure compliance with the requirements of this program;

(i) Provides information about the activities that will be carried out by the eligible entity to support systemic changes from which future cohorts of students will benefit; and

(j) Describes the sources of matching funds that will enable the eligible entity to meet the matching requirement described in section 404C(b) of the HEA.

IV. Application and Submission Information

1. Application Submission

Instructions: Applicants are required to follow the Common Instructions for Applicants to Department of Education Discretionary Grant Programs, published in the **Federal Register** on December 7, 2022 (87 FR 75045), and available at www.federalregister.gov/d/2022-26554, which contain requirements and information on how to submit an application.

2. *Intergovernmental Review*: This program is subject to Executive Order 12372 and the regulations in 34 CFR part 79. Information about Intergovernmental Review of Federal Programs under Executive Order 12372 is in the application package for this program.

3. *Funding Restrictions*: We reference regulations outlining funding restrictions in the *Applicable Regulations* section of this notice.

4. *Content and Form of Application Submission*: You must include your complete response to the selection criteria and the competitive preference priorities in the application narrative. Other requirements concerning the content of an application, together with the forms you must submit, are in the application package for this program.

5. *Recommended Page Limit*: The application narrative is where you, the applicant, address the selection criteria that reviewers use to evaluate your application. We recommend that you (1) limit the application narrative to no more than 65 pages and (2) use the following standards:

- A "page" is 8.5" x 11", on one side only, with 1" margins at the top, bottom, and both sides.

- Double space (no more than three lines per vertical inch) all the text in the application narrative, including titles, headings, footnotes, quotations,

references, captions, as well as all text in charts, tables, figures, and graphs.

- Use a font that is either 12 point or larger or no smaller than 10-pitch (characters per inch).

- Use one of the following fonts: Times New Roman, Courier, Courier New, or Arial.

The recommended page limit does not apply to the cover sheet; the budget section, including the narrative budget justification; the assurances and certifications or the one-page abstract. However, the recommended page limit does apply to all of the application narrative.

We recommend that any application addressing the competitive preference priorities include no more than three additional pages for each priority addressed. Applications that do not follow the page limit and formatting recommendations will not be penalized.

V. Application Review Information

1. *Selection Criteria:* The selection criteria for this competition are from 34 CFR 75.210.

a. *Need for project.* (up to 10 points)

(1) The Secretary considers the need for the proposed project.

(2) In determining the need for the proposed project, the Secretary considers:

(i) The magnitude or severity of the problem to be addressed by the proposed project (up to 4 points);

(ii) The extent to which the proposed project will provide services or otherwise address the needs of students at risk of educational failure (up to 3 points); and

(iii) The extent to which the proposed project will focus on serving or otherwise addressing the needs of disadvantaged individuals (up to 3 points).

b. *Quality of the project design.* (up to 30 points)

(1) The Secretary considers the quality of the design of the proposed project.

(2) In determining the quality of the design of the proposed project, the Secretary considers:

(i) The extent to which the goals, objectives, and outcomes to be achieved by the proposed project are clearly specified and measurable (up to 8 points);

(ii) The extent to which the proposed project demonstrates a rationale (as defined in this notice) (up to 7 points);

(iii) The extent to which the proposed project represents an exceptional approach for meeting statutory purposes and requirements (up to 8 points); and

(iv) How the applicant will ensure that a diversity of perspectives are

brought to bear in the operation of the proposed project, including those of parents, teachers, the business community, a variety of disciplinary and professional fields, recipients or beneficiaries of services, or others, as appropriate (up to 7 points).

c. *Adequacy of resources.* (up to 15 points)

(1) The Secretary considers the adequacy of resources for the proposed project.

(2) In determining the adequacy of resources for the proposed project, the Secretary considers:

(i) The adequacy of support, including facilities, equipment, supplies, and other resources, from the applicant organization or the lead applicant organization and the relevance and demonstrated commitment of each partner in the proposed project to the implementation and success of the project (up to 5 points);

(ii) The extent to which the costs are reasonable in relation to the number of persons to be served and to the anticipated results and benefits (up to 5 points); and

(iii) The potential for continued support of the project after Federal funding ends, including, as appropriate, the demonstrated commitment of appropriate entities to such support (up to 5 points).

d. *Quality of project personnel.* (up to 20 points)

(1) The Secretary considers the quality of the personnel who will carry out the proposed project.

(2) In determining the quality of project personnel, the Secretary considers the extent to which the applicant encourages applications for employment from persons who are members of groups that have traditionally been underrepresented based on race, color, national origin, gender, age or disability (up to 5 points).

(3) In addition, the Secretary considers:

(i) The qualifications, including relevant training and experience, of the project director or principal investigator (up to 5 points);

(ii) The qualifications, including relevant training and experience, of key project personnel (up to 5 points); and

(iii) The extent to which the time commitments of the project director and principal investigator and other key project personnel are appropriate and adequate to meet the objectives of the proposed project (up to 5 points).

e. *Quality of the project evaluation.* (up to 25 points)

(1) The Secretary considers the quality of the evaluation to be conducted of the proposed project.

(2) In determining the quality of the project evaluation, the Secretary considers the following factors:

(i) The extent to which the methods of evaluation include the use of objective performance measures that are clearly related to the intended outcomes of the project and will produce quantitative and qualitative data to the extent possible (up to 10 points);

(ii) The extent to which the methods of evaluation will provide performance feedback and permit periodic assessment of progress toward achieving intended outcomes (up to 10 points); and

(iii) The extent to which the methods of evaluation will, if well implemented, produce promising evidence (as defined in this notice) about the project's effectiveness. (up to 5 points).

Note: For purposes of the quality of the project evaluation, selection factor (iii), applicants can propose to evaluate a specific project component to build promising evidence of effectiveness about that strategy. Importantly, the project component that is the focus of evaluation selection factor (iii) does not need to be the same component for which evidence is provided in addressing Competitive Preference Priority 3 or the project design selection criteria.

2. *Review and Selection Process:* We remind potential applicants that in reviewing applications in any discretionary grant competition, the Secretary may consider, under 34 CFR 75.217(d)(3), the past performance of the applicant in carrying out a previous award, such as the applicant's use of funds, achievement of project objectives, and compliance with grant conditions. The Secretary may also consider whether the applicant failed to submit a timely performance report or submitted a report of unacceptable quality.

In addition, in making a competitive grant award, the Secretary requires various assurances including those applicable to Federal civil rights laws that prohibit discrimination in programs or activities receiving Federal financial assistance from the Department (34 CFR 100.4, 104.5, 106.4, 108.8, and 110.23).

As required by 20 U.S.C. 1070-a23(d), a panel of non-Federal reviewers will review each application in accordance with the procedures described in 34 CFR 75.217. The individual scores of the reviewers will be added and the sum divided by the number of reviewers to determine the peer review score received in the review process.

If there are insufficient funds for all applications with the same total scores, the Secretary will select applications

servicing LEA(s) with the highest poverty rate, using the most recent data available from the Small Area Income and Poverty Estimates Program (SAIPE) data (age range 5–17) or from the decennial census data for outlying areas, as appropriate. For applications that include multiple LEAs, the Department will aggregate data across LEAs to produce a simple poverty rate. For applications that include eligible charter schools as their LEA partners, the Department will use the State-derived equivalent of SAIPE data that the State uses to make allocations under Part A of Title I of the Elementary and Secondary Education Act of 1965, as amended.

3. *Risk Assessment and Special Conditions:* Consistent with 2 CFR 200.206, before awarding grants under this competition the Department conducts a review of the risks posed by applicants. Under 2 CFR 200.208, the Secretary may impose special conditions and, under 2 CFR 3474.10, in appropriate circumstances, high-risk conditions on a grant if the applicant or grantee is not financially stable; has a history of unsatisfactory performance; has a financial or other management system that does not meet the standards in 2 CFR part 200, subpart D; has not fulfilled the conditions of a prior grant; or is otherwise not responsible.

4. *Integrity and Performance System:* If you are selected under this competition to receive an award that over the course of the project period may exceed the simplified acquisition threshold (currently \$250,000), under 2 CFR 200.206(a)(2) we must make a judgment about your integrity, business ethics, and record of performance under Federal awards—that is, the risk posed by you as an applicant—before we make an award. In doing so, we must consider any information about you that is in the integrity and performance system (currently referred to as the Federal Awardee Performance and Integrity Information System (FAPIIS)), accessible through the System for Award Management. You may review and comment on any information about yourself that a Federal agency previously entered and that is currently in FAPIIS.

Please note that, if the total value of your currently active grants, cooperative agreements, and procurement contracts from the Federal Government exceeds \$10,000,000, the reporting requirements in 2 CFR part 200, Appendix XII, require you to report certain integrity information to FAPIIS semiannually. Please review the requirements in 2 CFR part 200, Appendix XII, if this grant plus all the other Federal funds you receive exceed \$10,000,000.

5. *In General:* In accordance with the Office of Management and Budget's guidance located at 2 CFR part 200, all applicable Federal laws, and relevant Executive guidance, the Department will review and consider applications for funding pursuant to this notice inviting applications in accordance with—

(a) Selecting recipients most likely to be successful in delivering results based on the program objectives through an objective process of evaluating Federal award applications (2 CFR 200.205);

(b) Prohibiting the purchase of certain telecommunication and video surveillance services or equipment in alignment with section 889 of the National Defense Authorization Act of 2019 (Pub. L. 115–232) (2 CFR 200.216);

(c) Providing a preference, to the extent permitted by law, to maximize use of goods, products, and materials produced in the United States (2 CFR 200.322); and

(d) Terminating agreements in whole or in part to the greatest extent authorized by law if an award no longer effectuates the program goals or agency priorities (2 CFR 200.340).

VI. Award Administration Information

1. *Award Notices:* If your application is successful, we notify your U.S. Representative and U.S. Senators and send you a Grant Award Notification (GAN), or we may send you an email containing a link to access an electronic version of your GAN. We also may notify you informally.

If your application is not evaluated or not selected for funding, we will notify you.

2. *Administrative and National Policy Requirements:* We identify administrative and national policy requirements in the application package and reference these and other requirements in the *Applicable Regulations* section of this notice.

We reference the regulations outlining the terms and conditions of an award in the *Applicable Regulations* section of this notice and include these and other specific conditions in the GAN. The GAN also incorporates your approved application as part of your binding commitments under the grant.

3. *Open Licensing Requirements:* Unless an exception applies, if you are awarded a grant under this competition, you will be required to openly license to the public grant deliverables created in whole, or in part, with Department grant funds. When the deliverable consists of modifications to pre-existing works, the license extends only to those modifications that can be separately identified and only to the extent that

open licensing is permitted under the terms of any licenses or other legal restrictions on the use of pre-existing works. Additionally, a grantee or subgrantee that is awarded competitive grant funds must have a plan to disseminate these public grant deliverables. This dissemination plan can be developed and submitted after your application has been reviewed and selected for funding. For additional information on the open licensing requirements please refer to 2 CFR 3474.20.

4. *Reporting:* (a) If you apply for a grant under this competition, you must ensure that you have in place the necessary processes and systems to comply with the reporting requirements in 2 CFR part 170 should you receive funding under the competition. This does not apply if you have an exception under 2 CFR 170.110(b).

(b) At the end of your project period, you must submit a final performance report, including financial information, as directed by the Secretary. If you receive a multiyear award, you must submit an annual performance report that provides the most current performance and financial expenditure information as directed by the Secretary under 34 CFR 75.118. The Secretary may also require more frequent performance reports under 34 CFR 75.720(c). For specific requirements on reporting, please go to www.ed.gov/fund/grant/apply/appforms/appforms.html.

(c) Under 34 CFR 75.250(b), the Secretary may provide a grantee with additional funding for data collection analysis and reporting. In this case the Secretary establishes a data collection period.

5. *Performance Measures:* The performance measures for the GEAR UP Program are established for purposes of Department reporting under 34 CFR 75.110. The objectives of the GEAR UP program are (1) to increase the academic performance and preparation for postsecondary education of participating students; (2) to increase the rate of high school graduation and participation in postsecondary education of participating students; and (3) to increase educational expectations for participating students and increase student and family knowledge of postsecondary education options, preparation, and financing.

The effectiveness of this program depends on the rate at which program participants complete high school and enroll in and complete a postsecondary education. We developed the following performance measures to track progress toward achieving the program's goals:

1. The percentage of GEAR UP students who pass Algebra 1 or its equivalent by the end of ninth grade.

2. The percentage of GEAR UP students who graduate from high school.

3. The percentage of GEAR UP students who complete the Free Application for Federal Student Aid.

4. The percentage of GEAR UP students and former GEAR UP students who are enrolled at an IHE.

5. The percentage of current GEAR UP students and former GEAR UP students who enrolled at an IHE and persisted to the second year of postsecondary education at the initial or a subsequent IHE.

In addition, to assess the efficiency of the program, we track the average cost, in Federal funds, of achieving a successful outcome, where success is defined as enrollment in a program of undergraduate instruction at an IHE of GEAR UP students immediately after high school graduation. These performance measures constitute GEAR UP's indicators of the success of the program. Accordingly, we request that applicants include these performance measures in conceptualizing the design, implementation, and evaluation of their proposed projects.

6. *Continuation Awards:* In making a continuation award under 34 CFR 75.253, the Secretary considers, among other things, whether a grantee has made substantial progress in achieving the goals and objectives of the project; whether the grantee has expended funds in a manner that is consistent with its approved application and budget; and, if the Secretary has established performance measurement requirements, whether the grantee has made substantial progress in achieving the performance targets in the grantee's approved application.

In making a continuation award, the Secretary also considers whether the grantee is operating in compliance with the assurances in its approved application, including those applicable to Federal civil rights laws that prohibit discrimination in programs or activities receiving Federal financial assistance from the Department (34 CFR 100.4, 104.5, 106.4, 108.8, and 110.23).

VII. Other Information

Accessible Format: On request to the program contact person listed under **FOR FURTHER INFORMATION CONTACT**, individuals with disabilities can obtain this document and a copy of the application package in an accessible format. The Department will provide the requestor with an accessible format that may include Rich Text Format (RTF) or

text format (txt), a thumb drive, an MP3 file, braille, large print, audiotape, or compact disc, or other accessible format.

Electronic Access to This Document: The official version of this document is the document published in the **Federal Register**. You may access the official edition of the **Federal Register** and the Code of Federal Regulations at www.govinfo.gov. At this site you can view this document, as well as all other documents of this Department published in the **Federal Register**, in text or Portal Document Format (PDF). To use PDF you must have Adobe Acrobat Reader, which is available free at the site.

You may also access documents of the Department published in the **Federal Register** by using the article search feature at: www.federalregister.gov. Specifically, through the advanced search feature at this site, you can limit your search to documents published by the Department.

Nasser H. Paydar,

Assistant Secretary for Postsecondary Education.

[FR Doc. 2024-04913 Filed 3-7-24; 8:45 am]

BILLING CODE 4000-01-P

DEPARTMENT OF EDUCATION

Applications for New Awards; Competitive Grants for State Assessments Program

AGENCY: Office of Elementary and Secondary Education, Department of Education.

ACTION: Notice.

SUMMARY: The Department of Education (Department) is issuing a notice inviting applications for fiscal year (FY) 2024 for the Competitive Grants for State Assessments (CGSA) program, Assistance Listing Number (ALN) 84.368A. This notice relates to the approved information collection under OMB control number 1894-0006.

DATES:

Applications Available: March 8, 2024.

Deadline for Notice of Intent To Apply: April 8, 2024.

Deadline for Transmittal of Applications: May 22, 2024.

Deadline for Intergovernmental Review: July 22, 2024.

ADDRESSES: For the addresses for obtaining and submitting an application, please refer to our Common Instructions for Applicants to Department of Education Discretionary Grant Programs, published in the **Federal Register** on December 7, 2022

(87 FR 75045), and available at <https://www.federalregister.gov/documents/2022/12/07/2022-26554/common-instructions-for-applicants-to-department-of-education-discretionary-grant-programs>. Please note that these Common Instructions supersede the version published on December 27, 2021.

FOR FURTHER INFORMATION CONTACT:

Donald Peasley, Office of Elementary and Secondary Education, U.S. Department of Education, 400 Maryland Avenue SW, room 4B113, Washington, DC 20202-6132. Telephone: (202) 453-7982. Email: ESEA.Assessment@ed.gov.

If you are deaf, hard of hearing, or have a speech disability and wish to access telecommunications relay services, please dial 7-1-1.

SUPPLEMENTARY INFORMATION:

Full Text of Announcement

I. Funding Opportunity Description

Purpose of Program: The purpose of the CGSA program is to enhance the quality of assessment instruments and assessment systems used by States for measuring the academic achievement and growth of elementary and secondary school students.

Background: High-quality assessment systems are a key component of a rich, rigorous instructional program for every student. At this pivotal moment of closing opportunity and achievement gaps and supporting student success, high-quality assessments can provide critical insights to educators, parents or caregivers, and students that can help inform teaching and learning in ways that meet all students' needs. When well-designed for their intended purposes, information from high-quality assessments support educators to Raise the Bar by meeting students where they are and helping them accelerate their learning and development. Information from these assessments can also help to identify the students with the greatest need for additional support who would benefit from additional evidence-based interventions and measuring the impact of those interventions. High-quality assessment systems include valid and reliable diagnostic, formative, interim, and summative assessments that are used appropriately and in a way that effectively inform teacher and promotes student learning.

Statewide summative assessments are among multiple tools that when well-designed can provide valuable information to students, parents or caregivers, educators, and the public about student outcomes and opportunity gaps. In a November 20, 2023, letter, Secretary Cardona noted

that, “Assessment data give insight into student learning, help guide instruction and meet students’ needs, and can also drive resources and strategies to address general underperformance and disparities in opportunities and outcomes for students.”¹ The Department encourages States to consider new and better ways to understand, evaluate, and respond to students’ knowledge and abilities, including through the use of multiple measures of student academic achievement and growth, focusing on higher-order thinking skills and understanding, and by including as part of the assessment system, portfolios, projects, or extended performance tasks which can provide students with additional ways to demonstrate their learning, including providing students with culturally and linguistically responsive ways of demonstrating progress.

In the November 2023 letter, the Secretary also announced changes to the Innovative Assessment Demonstration Authority (IADA) application process. IADA provides States an opportunity to pilot and scale over time new approaches to assessment systems that can drive authentic teaching and learning and which, when well-designed, can provide useful and timely information to educators, parents or caregivers, and schools to inform instruction and supports. Therefore, this CGSA competition is also an opportunity for interested States to receive support in planning to apply for IADA. Through a previous request for information on IADA,² the Department heard from a number of respondents the importance of time and funding to prepare to apply for IADA, and this is a key opportunity to provide those resources.

The Department also encourages States to consider how to build on technology advancement to allow for assessments to be conducted with more frequency and with fewer interruptions in instruction. In particular, technology advancement can support high-quality, instructionally embedded formative and diagnostic assessments that provide educators and parents or caregivers with valuable information as to where students are performing relative to their grade level throughout the year. As part of a comprehensive, aligned assessment system, formative and diagnostic

assessments can complement information from statewide assessments and be an important tool to help educators adjust their instructional approaches to meet student needs. In recognition of the crucial role that formative and diagnostic assessments play in closing academic achievement gaps, this notice includes an invitational priority supporting the development of such assessments. This invitational priority can be used in conjunction with any of the absolute or competitive priorities.

States are also encouraged to consider opportunities to administer statewide summative assessments through multiple statewide interim assessments during the course of the academic year (and that result in a single summative score that provides valid, reliable, and transparent information on student achievement or growth) as permitted under the ESEA.

This notice is aligned with the strategies outlined in the Secretary’s Supplemental Priorities and Definitions for Discretionary Grant Programs published in the **Federal Register** on December 10, 2021 (86 FR 70612)³ (Supplemental Priorities), which include developing and implementing high-quality assessments of student learning (e.g., curriculum-aligned and performance-based tools aligned with State grade-level content standards and, for career and technical education, relevant industry standards) and strategies that allow educators to use data from assessments to inform instructional design and classroom practices that meet the needs of all students and provide high-quality professional development to support educators in implementing these strategies. Building curriculum-aligned and performance-based tools and providing high-quality professional development that helps educators both use the assessments and appropriately use the resulting data can accelerate learning recovery and support students, educators, and families.

Section 1203(b)(1)(A) of the ESEA identifies six allowable uses of funds under CGSA. In brief, these uses include (1) developing or improving assessments for English learners; (2) developing or improving models to measure and assess student progress or student growth on assessments; (3) developing or improving assessments for children with disabilities; (4) collaborating with institutions of higher

education or other organizations to improve the quality, validity, and reliability of State academic assessments; (5) measuring student academic achievement using multiple measures of student academic achievement from multiple sources; and (6) evaluating student academic achievement using comprehensive academic assessment instruments (such as performance and technology-based academic assessments, computer adaptive assessments, projects, or extended performance task assessments) that emphasize the mastery of standards and aligned competencies in a competency-based education model. The last two statutory uses of funds are combined into an absolute priority in this competition.

These allowable uses of funds are not mutually exclusive. A State educational agency (SEA), or consortium of SEAs, applying for funds must identify how the proposed project addresses at least one of the absolute priorities in this CGSA competition. An applicant may propose to address any of the six allowed uses of funds, as long as it also addresses either of the absolute priorities in the *Priorities* section.

Grants awarded under Absolute Priority 1 promote deeper understanding of academic achievement of all student subgroups by supporting States in designing a statewide assessment system that meets Federal requirements and could do so by, for example, integrating information obtained from curriculum-embedded performance tasks or interim through-year assessments with information obtained from an end-of-year assessment to produce a valid, reliable, and fair measure of student achievement of State academic standards and are available for up to 48 months with a maximum budget request of \$4,000,000 for the total project period. Grants awarded under Absolute Priority 2 focus on planning to apply for the innovative assessment demonstration authority and are available for up to 24 months with a maximum budget request of the greater of either \$1,000,000 or the minimum permitted award size under CGSA, per statutory requirements, for the total project period (see the table in the application for the State-specific minimum award size).⁴ Applicants are required to clearly identify which of the absolute priorities they are addressing in their application. If an applicant erroneously selects both Absolute Priority 1 and Absolute Priority 2, or if

¹ See <https://oese.ed.gov/files/2023/11/23-0431-DCL-IADA-os-approved-11.17.2023.pdf>.

² The request for information is available at <https://www.federalregister.gov/documents/2023/03/31/2023-06697/request-for-information-regarding-the-innovative-assessment-demonstration-authority>.

³ Available at <https://www.federalregister.gov/documents/2021/12/10/2021-26615/final-priorities-and-definitions-secretarys-supplemental-priorities-and-definitions-for>.

⁴ The Department will not make an award for less than the amount specified in section 1203(b)(1)(C) of the ESEA.

an applicant fails to select either Absolute Priority 1 or 2, it will be subject to the maximum budget and timeframe noted above for Absolute Priority 2.

Competitive Preference Priority 1 is focused on supporting effective instruction and building educator capacity through the development of high-quality assessments of student learning and strategies that allow educators to use data from assessments to inform instruction.

Competitive Preference Priority 2 is focused on improving the utility of information about student performance included in reports of assessment results and providing better and more timely information to educators and parents.

The invitational priority is focused on developing high-quality formative, diagnostic, and/or interim assessments and tools that are part of a statewide, aligned assessment system to provide timely and actionable information to educators and parents or caregivers throughout the school year.

Priorities: This competition includes two absolute priorities, two competitive preference priorities, and one invitational priority. In accordance with 34 CFR 75.105(b)(2)(v), paragraph (a) of Absolute Priority 1 is from ESEA section 1201(a)(2)(K); and paragraph (b) of Absolute Priority 1 is from ESEA section 1201(a)(2)(L). Applicants may address either or both parts of this priority in order to be considered under Absolute Priority 1.

In accordance with 34 CFR 75.105(b)(2)(ii), Absolute Priority 2 is from the notice of final priorities (NFP) for the CGSA program, published in the **Federal Register** on May 1, 2020 (85 FR 25418) (2020 NFP).

In accordance with 34 CFR 75.105(b)(2)(v), Competitive Preference Priority 1 is from the Supplemental Priorities. Competitive Preference Priority 2 is from the notice of final priorities for the Enhanced Assessment Instruments Grant program, published in the **Federal Register** on August 8, 2016 (81 FR 52341) (2016 NFP).

Absolute Priorities: For FY 2024 and any subsequent year in which we make awards from the list of unfunded applications from this competition, these priorities are absolute priorities. Under 34 CFR 75.105(c)(3), we consider only applications that meet one or both of these priorities.

Each of the absolute priorities constitutes its own funding category, and the Department may award grants under each of these absolute priorities, provided that applications of sufficient quality are submitted. As a result, the

Department may fund applications out of the overall rank order, but the Department is not bound to do so. Applicants must clearly identify the specific absolute priority that the proposed project addresses. If an SEA (or consortium of SEAs) is interested in proposing separate projects (e.g., one that addresses Absolute Priority 1 and another that addresses Absolute Priority 2), the SEA (or consortium of SEAs) must submit separate applications. If an SEA (or consortium of SEAs) erroneously submits an application that identifies both absolute priorities, or that fails to identify either absolute priority, that application will only be considered under Absolute Priority 2.

These priorities are:

Absolute Priority 1: Under this priority, an SEA must describe an approach to address either or both of the following—

(a) Measuring student academic achievement using multiple measures of student academic achievement from multiple sources; and/or

(b) Evaluating student academic achievement through the development of comprehensive academic assessment instruments (such as performance and technology-based academic assessments, computer adaptive assessments, projects, or extended performance task assessments) that emphasize the mastery of standards and aligned competencies in a competency-based education model.

Absolute Priority 2: Planning to Apply for the Innovative Assessment Demonstration Authority (IADA).

Under this priority, SEAs must—

(a) Provide an assurance by an authorized representative that the SEA intends to apply for flexibility under the IADA,⁵ when made available by the Department. If applying for CGSA as part of a consortium (or in partnership with other SEAs), each SEA must provide an assurance that it intends to apply for flexibility under the IADA;

(b) If applying as a consortium of SEAs during the initial demonstration authority for IADA, not include more than four SEAs; and

(c) Describe their approach to innovative assessments in terms of the subjects and grades the SEA anticipates addressing, the proposed assessment design, proposed item types (e.g., item prototypes), and other relevant features.

⁵ See “Applying for the IADA” available at: <https://oese.ed.gov/offices/office-of-formula-grants/school-support-and-accountability/iada/>. The next IADA application deadlines are May 3, 2024, or December 6, 2024. Following that, the Department expects to have application deadlines each May and December in future years.

Note: Because the initial demonstration period for the IADA has ended,⁶ item (b) listed above does not apply in this competition.

Competitive Preference Priorities: For FY 2024 and any subsequent year in which we make awards from the list of unfunded applications from this competition, these priorities are competitive preference priorities. Under 34 CFR 75.105(c)(2)(i), the Department awards up to an additional 3 points to an application, depending on how well the application meets Competitive Preference Priority 1, and we award up to an additional 2 points to an application depending on how well the application meets Competitive Preference Priority 2. Applicants should identify which of the competitive priorities they are addressing in their application.

These priorities are:

Competitive Preference Priority 1: Supporting a Diverse Educator Workforce and Professional Growth to Strengthen Student Learning. (Up to 3 points)

Projects that are designed to increase the proportion of well-prepared, diverse, and effective educators serving students, with a focus on underserved students, through supporting effective instruction and building educator capacity by developing and implementing high-quality assessments (as defined in this notice) of student learning (for example, curriculum-aligned and performance-based tools aligned with State grade-level content standards or, for career and technical education, relevant industry standards) and strategies that allow educators to use the data from assessments to inform instructional design and classroom practices that meet the needs of all students, and providing high-quality professional development to support educators in implementing these strategies.

Competitive Preference Priority 2: Improving Assessment Scoring and Score Reporting. (Up to 2 points)

Under this priority, SEAs must:

(a) Develop innovative tools that leverage technology to score assessments;

(1) To respond to paragraph (a), applicants must propose projects to reduce the time it takes to provide test results to educators, parents, and students and to make it more cost-effective to include non-multiple choice items on assessments. These innovative tools must improve automated scoring of student assessments, in particular

⁶ See <https://oese.ed.gov/files/2023/11/23-0431-DCL-IADA-os-approved-11.17.2023.pdf>.

non-multiple choice items in reading/language arts, mathematics, or science; or

(b) Propose projects, in consultation with organizations representing parents (including parents of English learners and parents of students with disabilities), students, teachers, counselors, and school administrators to address needs related to score reporting, and improve the utility of information about student performance included in reports of assessment results, and provide better and more timely information to educators and parents;

(1) To respond to paragraph (b), applicants must include one or more of the following in their projects:

(i) Developing enhanced score reporting templates or digital mechanisms for communicating assessment results and their meaning (such as by providing clear and actionable next steps for parents);

(ii) Improving the assessment literacy of educators and parents to help them interpret test results and to support teaching and learning in the classroom (such as by providing training on test development and interpretation of test scores); and

(iii) Developing mechanisms for secure transmission and individual use of assessment results by teachers, students, and parents.⁷

(c) Applicants proposing projects under either paragraph (a) or (b) must provide a dissemination plan for sharing lessons learned and best practices such that their projects can serve as models and resources that can be shared with other States.

Invitational Priority: For FY 2024 and any subsequent year in which we make awards from the list of unfunded applications from this competition, this priority is an invitational priority. Under 34 CFR 75.105(c)(1) we do not give an application that meets an invitational priority any preference over other applications.

This priority is: Projects that propose to develop, improve, or scale high-quality formative, diagnostic, and/or interim assessments and tools that, to the greatest extent feasible, are part of a statewide, aligned assessment system to provide timely and actionable information to educators and parents or caregivers throughout the school year.

Application Requirement: For FY 2024 and any subsequent year in which we make awards from the list of unfunded applications from this

competition, applicants must meet the following uses of funds application requirements from section 1203(b)(1)(B) of the ESEA, which refers to section 1201(a)(2)(C) and (H)–(L) of the ESEA.

Uses of Funds: As required by statute and stated earlier in this notice, applicants must demonstrate that their proposed uses of funds for CGSA would be to carry out one or more of the following activities:

(a) Developing or improving assessments for English learners, including assessments of English language proficiency as required under section 1111(b)(2)(G) of the ESEA and academic assessments in languages other than English to meet the State's obligations under section 1111(b)(2)(F) of the ESEA.

(b) Developing or improving models to measure and assess student progress or student growth on State assessments under section 1111(b)(2) of the ESEA and other assessments not required under section 1111(b)(2) of the ESEA.

(c) Developing or improving assessments for children with disabilities, including alternate assessments aligned to alternate academic achievement standards for students with the most significant cognitive disabilities described in section 1111(b)(2)(D) of the ESEA, and using the principles of universal design for learning.

(d) Allowing for collaboration with institutions of higher education, other research institutions, or other organizations to improve the quality, validity, and reliability of State academic assessments beyond the requirements for such assessments described in section 1111(b)(2) of the ESEA.

(e) Measuring student academic achievement using multiple measures of student academic achievement from multiple sources.

(f) Evaluating student academic achievement through the development of comprehensive academic assessment instruments (such as performance and technology-based academic assessments, computer adaptive assessments, projects, or extended performance task assessments) that emphasize the mastery of standards and aligned competencies in a competency-based education model.

Definitions: For FY 2024 and any subsequent year in which we make awards from the list of unfunded applications from this competition, the following definitions apply. The definition of “Universal design for learning” and, except as specified below, the definitions of “Child with a disability” and “English learner” are

from section 8101 of the ESEA (20 U.S.C. 7801). The definitions of “Demonstrates a rationale,” “Logic model,” “Project component,” and “Relevant outcome” are from 34 CFR 77.1. The definitions of “Disconnected youth,” “High-quality assessment,” and “Underserved student” are from the Supplemental Priorities.

Child with a disability, as defined in section 602 of the Individuals with Disabilities Education Act, means—

(A) A child—

(i) With intellectual disabilities, hearing impairments (including deafness), speech or language impairments, visual impairments (including blindness), serious emotional disturbance (referred to in the IDEA as “emotional disturbance”), orthopedic impairments, autism, traumatic brain injury, other health impairments, or specific learning disabilities; and

(ii) Who, by reason thereof, needs special education and related services.

(B) The term “child with a disability” for a child aged 3 through 9 (or any subset of that age range, including ages three through five), may, at the discretion of the State and the local educational agency, include a child—

(i) Experiencing developmental delays, as defined by the State and as measured by appropriate diagnostic instruments and procedures, in 1 or more of the following areas: physical development; cognitive development; communication development; social or emotional development; or adaptive development; and

(ii) Who, by reason thereof, needs special education and related services.

Demonstrates a rationale means a key project component included in the project's logic model is informed by research or evaluation findings that suggest the project component is likely to improve relevant outcomes.

Disconnected youth, means an individual, between the ages 14 and 24, who may be from a low-income background, experiences homelessness, is in foster care, is involved in the justice system, or is not working or not enrolled in (or at risk of dropping out of) an educational institution.

English learner, when used with respect to an individual, means an individual—

(A) Who is aged 3 through 21;

(B) Who is enrolled or preparing to enroll in an elementary school or secondary school;

(C)(i) Who was not born in the United States or whose native language is a language other than English;

(ii)(I) Who is a Native American or Alaska Native, or a native resident of the outlying areas; and

⁷Note that the applicant will need to ensure it transmits information consistent with the Family Educational Rights and Privacy Act (FERPA). For more information, see: <https://www2.ed.gov/policy/gen/guid/fpco/ferpa/index.html>.

(II) Who comes from an environment where a language other than English has had a significant impact on the individual's level of English language proficiency; or

(iii) Who is migratory, whose native language is a language other than English, and who comes from an environment where a language other than English is dominant; and

(D) Whose difficulties in speaking, reading, writing, or understanding the English language may be sufficient to deny the individual—

(i) The ability to meet the challenging State academic standards;

(ii) The ability to successfully achieve in classrooms where the language of instruction is English; or

(iii) The opportunity to participate fully in society.

High-quality assessments mean diagnostic, formative, interim, or summative assessments that are valid and reliable for the purposes for which they are used and that provide relevant and timely information to help educators, parents or caregivers, and policymakers support students at the student, classroom, school, and system levels.

Logic model (also referred to as a theory of action) means a framework that identifies key project components of the proposed project (*i.e.*, the active “ingredients” that are hypothesized to be critical to achieving the relevant outcomes) and describes the theoretical and operational relationships among the key project components and relevant outcomes.

Project component means an activity, strategy, intervention, process, product, practice, or policy included in a project. Evidence may pertain to an individual project component or to a combination of project components (*e.g.*, training teachers on instructional practices for English learners and follow-on coaching for these teachers).

Relevant outcome means the student outcome(s) or other outcome(s) the key project component is designed to improve, consistent with the specific goals of the program.

Underserved student means a student (which may include children in early learning environments, students in K–12 programs, students in postsecondary education or career and technical education, and adult learners, as appropriate) in one or more of the following subgroups:

(a) A student who is living in poverty or is served by schools with high concentrations of students living in poverty.

(b) A student of color.

(c) A student who is a member of a federally recognized Indian Tribe.

(d) An English learner.

(e) A child or student with a disability.

(f) A disconnected youth.

(g) A technologically unconnected youth.

(h) A migrant student.

(i) A student experiencing homelessness or housing insecurity.

(j) A lesbian, gay, bisexual, transgender, queer or questioning, or intersex (LGBTQI+) student.

(k) A student who is in foster care.

(l) A student without documentation of immigration status.

(m) A pregnant, parenting, or caregiving student.

(n) A student impacted by the justice system, including a formerly incarcerated student.

(o) A student performing significantly below grade level.

(p) A military- or veteran-connected student.

For the purpose of this definition—

Children or students with disabilities means children with disabilities as defined in section 602(3) of the Individuals with Disabilities Education Act (IDEA) (20 U.S.C. 1401(3)) and 34 CFR 300.8, or students with disabilities, as defined in the Rehabilitation Act of 1973 (29 U.S.C. 705(37), 705(202)(B)); and

English learner means an individual who is an English learner as defined in section 8101(20) of the ESEA.

Universal design for learning, as defined under section 103 of the Higher Education Act of 1965, as amended, means a scientifically valid framework for guiding educational practice that—

(a) Provides flexibility in the ways information is presented, in the ways students respond or demonstrate knowledge and skills, and in the ways students are engaged; and

(b) Reduces barriers in instruction, provides appropriate accommodations, supports, and challenges, and maintains high achievement expectations for all students, including students with disabilities and students who are limited English proficient.⁸

Program Authority: Section 1203(b)(1) of the ESEA (20 U.S.C. 6363(b)(1)).

Note: Projects will be awarded and must be operated in a manner consistent with the nondiscrimination requirements contained in Federal civil rights laws.

Applicable Regulations: (a) The Education Department General

Administrative Regulations in 34 CFR parts 75, 77, 79, 81, 82, 84, 86, 97, 98, and 99. (b) The Office of Management and Budget Guidelines to Agencies on Governmentwide Debarment and Suspension (Nonprocurement) in 2 CFR part 180, as adopted and amended as regulations of the Department in 2 CFR part 3485. (c) The Uniform Administrative Requirements, Cost Principles, and Audit Requirements for Federal Awards in 2 CFR part 200, as adopted and amended as regulations of the Department in 2 CFR part 3474. (d) The 2016 NFP. (e) The 2020 NFP. (f) The Supplemental Priorities.

II. Award Information

Type of Award: Discretionary grants.

Estimated Available Funds: At least \$18,993,000.

Contingent upon the availability of funds and the quality of applications, we may make additional awards in FY 2024 (or later) from the list of unfunded applications from this competition.

Estimated Range of Awards for the

Project Period:

\$1,000,000 to \$4,000,000.

Estimated Average Size of Awards for the Project Period: \$2,500,000.

Maximum Size of Awards for the

Project Period: We will not make an award exceeding \$4,000,000 for an application submitted under Absolute Priority 1.

We will not make an award exceeding the greater of either \$1,000,000 or the minimum permitted award size under CGSA, per statutory requirements, for an application submitted under Absolute Priority 2 for the total project period (see the table in the application for the State-specific minimum award size).

If an SEA (or consortium of SEAs) erroneously submits an application that identifies both absolute priorities, or that fails to identify either absolute priority, that application will only be considered under Absolute Priority 2.

Note: The Department will not make an award under either of the absolute priorities for less than the amount specified in section 1203(b)(1)(C) of the ESEA.

Estimated Number of Awards: 3 to 6.

Note: The Department is not bound by any estimates in this notice.

Project Period:

For projects Under Absolute Priority 1: Up to 48 months.

For projects Under Absolute Priority 2: Up to 24 months.

III. Eligibility Information

1. *Eligible Applicants*: SEAs, as defined in section 8101(49) of the ESEA, of the 50 States, the District of

⁸ For purposes of this notice, “English learner” and “limited English proficient” have the same meaning.

Columbia, and the Commonwealth of Puerto Rico, and consortia of such SEAs.

2. a. *Cost Sharing or Matching*: This competition does not require cost sharing or matching.

b. *Indirect Cost Rate Information*: This program uses an unrestricted indirect cost rate. For more information regarding indirect costs, or to obtain a negotiated indirect cost rate, please see www2.ed.gov/about/offices/list/ocfo/intro.html.

c. *Administrative Cost Limitation*: This program does not include any program-specific limitation on administrative expenses. All administrative expenses must be reasonable and necessary and conform to Cost Principles described in 2 CFR part 200 subpart E of the Uniform Guidance.

3. *Subgrantees*: A grantee under this competition may not award subgrants to entities to directly carry out project activities described in its application.

4. *Other*: An application from a consortium of SEAs must designate one SEA as the fiscal agent.

IV. Application and Submission Information

1. Application Submission

Instructions: Applicants are required to follow the Common Instructions for Applicants to Department of Education Discretionary Grant Programs, published in the **Federal Register** on December 7, 2022 (87 FR 75045) and available at <https://www.federalregister.gov/documents/2022/12/07/2022-26554/common-instructions-for-applicants-to-department-of-education-discretionary-grant-programs>, which contain requirements and information on how to submit an application. Please note that these Common Instructions supersede the version published on December 27, 2021.

2. *Submission of Proprietary Information*: Given the types of projects that may be proposed in applications for the CGSA, your application may include business information that you consider proprietary. In 34 CFR 5.11, we define “business information” and describe the process we use in determining whether any of that information is proprietary and, thus, protected from disclosure under Exemption 4 of the Freedom of Information Act (5 U.S.C. 552, as amended). Because we plan to make all application materials public, you may wish to request confidentiality of business information.

Consistent with Executive Order 12600, please designate in your application any information that you

believe is exempt from disclosure under Exemption 4. In the appropriate Appendix section of your application, under “Other Attachments Form,” please list the page number or numbers on which we can find this information. For additional information please see 34 CFR 5.11(c).

3. *Intergovernmental Review*: This competition is subject to Executive Order 12372 and the regulations in 34 CFR part 79. Information about Intergovernmental Review of Federal Programs under Executive Order 12372 is in the application package for this competition.

4. *Funding Restrictions*: We reference regulations outlining funding restrictions in the *Applicable Regulations* section of this notice.

5. *Recommended Page Limit*: The project narrative is where you, the applicant, address the selection criteria that reviewers use to evaluate your application. We recommend that you (1) limit the application narrative to the equivalent of no more than 65 pages and (2) use the following standards:

- A “page” is 8.5” x 11”, on one side only, with 1” margins at the top, bottom, and both sides.
- Double space (no more than three lines per vertical inch) all text in the application narrative, including titles, headings, footnotes, quotations, references, and captions, as well as all text in charts, tables, figures, and graphs.

- Use a font that is either 12 point or larger or no smaller than 10 pitch (characters per inch).

- Use one of the following fonts: Times New Roman, Courier, Courier New, or Arial.

The recommended page limit applies to the project narrative, including the table of contents, which must include a discussion of how the application meets one of the absolute priorities, and how well the application addresses each of the selection criteria. The recommended page limit also applies to any attachments to the project narrative other than the items mentioned in Part 6 of the application package, including the references/bibliography. In other words, we recommend that the entirety of the project narrative, including the aforementioned discussion and any attachments to the project narrative, be limited to the equivalent of no more than 65 pages. The only allowable attachments other than those included in the project narrative are outlined in Part 6, “Other Attachments Forms,” in the application package.

The recommended 65-page limit, or its equivalent, does not apply to the following sections of an application:

Part 1 (including the response regarding research activities involving human subjects); Part 2 (budget information); Part 3 (two-page project abstract); Part 5 (the budget narrative); Part 6 (memoranda of understanding or other binding agreement, if applicable; copy of applicant’s indirect cost rate agreement; letters of commitment and support from collaborating SEAs and organizations; other attachments forms, including, if applicable, references/bibliography for the project narrative and individual résumés for project director(s) and key personnel); and Part 7 (standard assurances and certifications). Applicants are encouraged to limit each résumé to no more than five pages.

Please note, hyperlinks should not be used in an application. Reviewers will be instructed not to follow hyperlinks if included. Applicants are encouraged to submit applications that meet the page limit following the standards outlined in this section rather than submitting applications that are the equivalent of the page limit applying other standards.

6. *Notice of Intent to Apply*: The Department will be able to review grant applications more efficiently if we know the approximate number of applicants that intend to apply. Therefore, we strongly encourage each potential applicant to notify us of the applicant’s intent to submit an application for funding and which absolute priority the applicant intends to address. This notification should be brief and identify the SEA applicant and, in the case of consortia applicants, the SEA that it will designate as the fiscal agent for an award. Submit this notification by email to ESEA.Assessment@ed.gov with “Intent to Apply” in the email subject line. Applicants that do not provide this notification may still apply for funding.

V. Application Review Information

1. *Selection Criteria*: The selection criteria for this competition are from 34 CFR 75.210. We will award up to 100 points to an application under the selection criteria; the total possible points for each selection criterion are noted in parentheses.

(a) *Significance* (up to 10 points).

The Secretary considers the significance of the proposed project. In determining the significance of the proposed project, the Secretary considers the following factors:

(1) The extent to which the proposed project is likely to build local capacity to provide, improve, or expand services that address the needs of the target population. (Up to 5 points)

(2) The likely utility of the products (such as information, materials,

processes, or techniques) that will result from the proposed project, including the potential for their being used effectively in a variety of other settings. (Up to 5 points)

(b) *Quality of the project design* (Up to 25 points).

The Secretary considers the quality of the design of the proposed project. In determining the quality of the design of the proposed project, the Secretary considers the following factors:

(1) The extent to which the goals, objectives, and outcomes to be achieved by the proposed project are clearly specified and measurable. (Up to 10 points)

(2) The extent to which the proposed project is part of a comprehensive effort to improve teaching and learning and support rigorous academic standards for students. (Up to 10 points)

(3) The extent to which the proposed project demonstrates a rationale (as defined in this notice). (Up to 5 points)

(c) *Quality of project services* (Up to 35 points).

The Secretary considers the quality of the services to be provided by the proposed project. In determining the quality of the services to be provided by the proposed project, the Secretary considers:

(1) The quality and sufficiency of strategies for ensuring equal access and treatment for eligible project participants who are members of groups that have traditionally been underrepresented based on race, color, national origin, gender, age, or disability. (Up to 10 points)

(2) The extent to which the services to be provided by the proposed project are appropriate to the needs of the intended recipients or beneficiaries of those services. (Up to 10 points)

(3) The extent to which the training or professional development services to be provided by the proposed project are of sufficient quality, intensity, and duration to lead to improvements in practice among the recipients of those services. (Up to 15 points)

(d) *Adequacy of resources* (Up to 10 points).

The Secretary considers the adequacy of resources for the proposed project. In determining the adequacy of resources for the proposed project, the Secretary considers the extent to which the costs are reasonable in relation to the number of persons to be served and to the anticipated results and benefits.

(e) *Quality of the management plan* (Up to 15 points).

The Secretary considers the quality of the management plan for the proposed project. In determining the quality of the

management plan for the proposed project, the Secretary considers:

(1) The adequacy of the management plan to achieve the objectives of the proposed project on time and within budget, including clearly defined responsibilities, timelines, and milestones for accomplishing project tasks. (Up to 5 points)

(2) The extent to which the time commitments of the project director and principal investigator and other key project personnel are appropriate and adequate to meet the objectives of the proposed project. (Up to 10 points)

(f) *Quality of the project evaluation* (Up to 5 points).

The Secretary considers the quality of the evaluation to be conducted of the proposed project. In determining the quality of the evaluation, the Secretary considers the extent to which the methods of evaluation are thorough, feasible, and appropriate to the goals, objectives, and outcomes of the proposed project.

2. Review and Selection Process: We remind potential applicants that in reviewing applications in any discretionary grant competition, the Secretary may consider, under 34 CFR 75.217(d)(3), the past performance of the applicant in carrying out a previous award, such as the applicant's use of funds, achievement of project objectives, and compliance with grant conditions. The Secretary may also consider whether the applicant failed to submit a timely performance report or submitted a report of unacceptable quality.

In addition, in making a competitive grant award, the Secretary requires various assurances, including those applicable to Federal civil rights laws that prohibit discrimination in programs or activities receiving Federal financial assistance from the Department (34 CFR 100.4, 104.5, 106.4, 108.8, and 110.23).

3. Risk Assessment and Specific Conditions: Consistent with 2 CFR 200.206, before awarding grants under this competition the Department conducts a review of the risks posed by applicants. Under 2 CFR 200.208, the Secretary may impose specific conditions and, under 2 CFR 3474.10, in appropriate circumstances, high-risk conditions on a grant if the applicant or grantee is not financially stable; has a history of unsatisfactory performance; has a financial or other management system that does not meet the standards in 2 CFR part 200, subpart D; has not fulfilled the conditions of a prior grant; or is otherwise not responsible.

4. Integrity and Performance System: If you are selected under this competition to receive an award that

over the course of the project period may exceed the simplified acquisition threshold (currently \$250,000), under 2 CFR 200.206(a)(2), we must make a judgment about your integrity, business ethics, and record of performance under Federal awards—that is, the risk posed by you as an applicant—before we make an award. In doing so, we must consider any information about you that is in the integrity and performance system (currently referred to as the Federal Awardee Performance and Integrity Information System (FAPIIS)), accessible through SAM. You may review and comment on any information about yourself that a Federal agency previously entered and that is currently in FAPIIS.

Please note that, if the total value of your currently active grants, cooperative agreements, and procurement contracts from the Federal Government exceeds \$10,000,000, the reporting requirements in 2 CFR part 200, Appendix XII, require you to report certain integrity information to FAPIIS semiannually. Please review the requirements in 2 CFR part 200, Appendix XII, if this grant plus all the other Federal funds you receive exceed \$10,000,000.

5. In General: In accordance with the Office of Management and Budget's guidance located at 2 CFR part 200, all applicable Federal laws, and relevant Executive guidance, the Department will review and consider applications for funding pursuant to this notice inviting applications in accordance with:

(a) Selecting recipients most likely to be successful in delivering results based on the program objectives through an objective process of evaluating Federal award applications (2 CFR 200.205);

(b) Prohibiting the purchase of certain telecommunication and video surveillance services or equipment in alignment with section 889 of the National Defense Authorization Act of 2019 (Pub. L. 115—232) (2 CFR 200.216);

(c) Providing a preference, to the extent permitted by law, to maximize use of goods, products, and materials produced in the United States (2 CFR 200.322); and

(d) Terminating agreements in whole or in part to the greatest extent authorized by law if an award no longer effectuates the program goals or agency priorities (2 CFR 200.340).

VI. Award Administration Information

1. Award Notices: If your application is successful, we notify your U.S. Representative and U.S. Senators and send you a Grant Award Notification (GAN), or we may send you an email

containing a link to access an electronic version of your GAN. We may notify you informally, also.

If your application is not evaluated or not selected for funding, we notify you.

2. Administrative and National Policy Requirements: We identify administrative and national policy requirements in the application package and reference these and other requirements in the *Applicable Regulations* section of this notice.

We reference the regulations outlining the terms and conditions of an award in the *Applicable Regulations* section of this notice and include these and other specific conditions in the GAN. The GAN also incorporates your approved application as part of your binding commitments under the grant.

3. Open Licensing Requirements: Unless an exception applies, if you are awarded a grant under this competition, you will be required to openly license to the public grant deliverables created in whole, or in part, with Department grant funds. When the deliverable consists of modifications to preexisting works, the license extends only to those modifications that can be separately identified and only to the extent that open licensing is permitted under the terms of any licenses or other legal restrictions on the use of preexisting works. Additionally, a grantee or subgrantee that is awarded competitive grant funds must have a plan to disseminate these public grant deliverables. This dissemination plan can be developed and submitted after your application has been reviewed and selected for funding. For additional information on the open licensing requirements please refer to 2 CFR 3474.20.

4. Reporting: (a) If you apply for a grant under this competition, you must ensure that you have in place the necessary processes and systems to comply with the reporting requirements in 2 CFR part 170 should you receive funding under the competition. This does not apply if you have an exception under 2 CFR 170.110(b).

(b) At the end of your project period, you must submit a final performance report, including financial information, as directed by the Secretary. If you receive a multiyear award, you must submit an annual performance report that provides the most current performance and financial expenditure information as directed by the Secretary under 34 CFR 75.118. The Secretary may also require more frequent performance reports under 34 CFR 75.720(c). For specific requirements on reporting, please go to www.ed.gov/

fund/grant/apply/appforms/appforms.html.

(c) Under 34 CFR 75.250(b), the Secretary may provide a grantee with additional funding for data collection analysis and reporting. In this case the Secretary establishes a data collection period.

5. Performance Measures: For purposes of Department reporting under 34 CFR 75.110, the Department has developed three measures to evaluate the overall effectiveness of the CGSA program:

(1) The percentage of grantees, for each grant cycle, that demonstrate significant progress towards improving, developing, or implementing a new model for measuring the achievement or growth of students.

(2) The percentage of grantees, for each grant cycle, that demonstrate collaboration with institutions of higher education, other research institutions, or other organizations to develop or improve State assessments.

(3) The percentage of grantees that, at least three times during the period of their grants, make available to SEA staff in non-participating States and to assessment researchers information on findings resulting from the CGSA program through presentations at national conferences, publications in refereed journals, or other products disseminated to the assessment community.

Grantees will be expected to include in their interim and final performance reports information about the accomplishments of their projects.

VII. Other Information

Accessible Format: On request to the program contact person listed under **FOR FURTHER INFORMATION CONTACT**, individuals with disabilities can obtain this document and a copy of the application package in an accessible format. The Department will provide the requestor with an accessible format that may include Rich Text Format (RTF) or text format (txt), a thumb drive, an MP3 file, braille, large print, audiotape, or compact disc, or other accessible format.

Electronic Access to This Document: The official version of this document is the document published in the **Federal Register**. You may access the official edition of the **Federal Register** and the Code of Federal Regulations at www.govinfo.gov. At this site you can view this document, as well as all other documents of this Department published in the **Federal Register**, in text or Portable Document Format (PDF). To use PDF you must have Adobe Acrobat Reader, which is available free at the site.

You may also access documents of the Department published in the **Federal Register** by using the article search feature at: www.federalregister.gov. Specifically, through the advanced search feature at this site, you can limit your search to documents published by the Department.

Adam Schott,

Principal Deputy Assistant Secretary, Delegated the Authority to Perform the Functions and Duties of the Assistant Secretary, Office of Elementary and Secondary Education.

[FR Doc. 2024-04972 Filed 3-7-24; 8:45 am]

BILLING CODE 4000-01-P

DEPARTMENT OF ENERGY

Federal Energy Regulatory Commission

[Project No. 2514-000]

Appalachian Power Company; Notice of Authorization for Continued Project Operation

The license for the Bylesby-Buck Hydroelectric Project No. 2514 was issued for a period ending February 29, 2024.

Section 15(a)(1) of the FPA, 16 U.S.C. 808(a)(1), requires the Commission, at the expiration of a license term, to issue from year-to-year an annual license to the then licensee(s) under the terms and conditions of the prior license until a new license is issued, or the project is otherwise disposed of as provided in section 15 or any other applicable section of the FPA. If the project's prior license waived the applicability of section 15 of the FPA, then, based on section 9(b) of the Administrative Procedure Act, 5 U.S.C. 558(c), and as set forth at 18 CFR 16.21(a), if the licensee of such project has filed an application for a subsequent license, the licensee may continue to operate the project in accordance with the terms and conditions of the license after the minor or minor part license expires, until the Commission acts on its application. If the licensee of such a project has not filed an application for a subsequent license, then it may be required, pursuant to 18 CFR 16.21(b), to continue project operations until the Commission issues someone else a license for the project or otherwise orders disposition of the project.

If the project is subject to section 15 of the FPA, notice is hereby given that an annual license for Project No. 2514 is issued to Appalachian Power Company for a period effective March 1, 2024, through February 28, 2025, or

until the issuance of a new license for the project or other disposition under the FPA, whichever comes first.

If issuance of a new license (or other disposition) does not take place on or before February 28, 2025, notice is hereby given that, pursuant to 18 CFR 16.18(c), an annual license under section 15(a)(1) of the FPA is renewed automatically without further order or notice by the Commission, unless the Commission orders otherwise.

If the project is not subject to section 15 of the FPA, notice is hereby given that Appalachian Power Company is authorized to continue operation of the Byllesby-Buck Hydroelectric Project under the terms and conditions of the prior license until the issuance of a subsequent license for the project or other disposition under the FPA, whichever comes first.

Dated: March 1, 2024.

Debbie-Anne A. Reese,
Acting Secretary.

[FR Doc. 2024-04916 Filed 3-7-24; 8:45 am]

BILLING CODE 6717-01-P

DEPARTMENT OF ENERGY

Federal Energy Regulatory Commission

[Project No. 8866-000]

Black Canyon Bliss, LLC; Notice of Authorization for Continued Project Operation

The license for the Stevenson No. 2 Hydroelectric Project No. 8866 was issued for a period ending February 29, 2024.

Section 15(a)(1) of the FPA, 16 U.S.C. 808(a)(1), requires the Commission, at the expiration of a license term, to issue from year-to-year an annual license to the then licensee(s) under the terms and conditions of the prior license until a new license is issued, or the project is otherwise disposed of as provided in section 15 or any other applicable section of the FPA. If the project's prior license waived the applicability of section 15 of the FPA, then, based on section 9(b) of the Administrative Procedure Act, 5 U.S.C. 558(c), and as set forth at 18 CFR 16.21(a), if the licensee of such project has filed an application for a subsequent license, the licensee may continue to operate the project in accordance with the terms and conditions of the license after the minor or minor part license expires, until the Commission acts on its application. If the licensee of such a project has not filed an application for a subsequent license, then it may be

required, pursuant to 18 CFR 16.21(b), to continue project operations until the Commission issues someone else a license for the project or otherwise orders disposition of the project.

If the project is subject to section 15 of the FPA, notice is hereby given that an annual license for Project No. 8866 is issued to Black Canyon Bliss, LLC for a period effective March 1, 2024, through February 28, 2025, or until the issuance of a new license for the project or other disposition under the FPA, whichever comes first.

If issuance of a new license (or other disposition) does not take place on or before February 28, 2025, notice is hereby given that, pursuant to 18 CFR 16.18(c), an annual license under section 15(a)(1) of the FPA is renewed automatically without further order or notice by the Commission, unless the Commission orders otherwise.

If the project is not subject to section 15 of the FPA, notice is hereby given that Black Canyon Bliss, LLC is authorized to continue operation of the Stevenson No. 2 Hydroelectric Project under the terms and conditions of the prior license until the issuance of a subsequent license for the project or other disposition under the FPA, whichever comes first.

Dated: March 1, 2024.

Debbie-Anne A. Reese,
Acting Secretary.

[FR Doc. 2024-04911 Filed 3-7-24; 8:45 am]

BILLING CODE 6717-01-P

DEPARTMENT OF ENERGY

Federal Energy Regulatory Commission

Combined Notice of Filings

Take notice that the Commission has received the following Natural Gas Pipeline Rate and Refund Report filings:

Filings Instituting Proceedings

Docket Numbers: PR24-56-000.
Applicants: Columbia Gas of Ohio, Inc.
Description: 284.123 Rate Filing; COH Rates effective 1-31-2024 to be effective 1/31/2024.
Filed Date: 3/1/24.
Accession Number: 20240301-5079.
Comment Date: 5 p.m. ET 3/22/24.
Docket Numbers: RP24-458-000.
Applicants: El Paso Natural Gas Company, L.L.C.
Description: 4(d) Rate Filing; Negotiated Rate Agreement Update (Conoco Mar 2024) to be effective 3/1/2024.
Filed Date: 2/29/24.

Accession Number: 20240229-5159.
Comment Date: 5 p.m. ET 3/12/24.
Docket Numbers: RP24-459-000.
Applicants: Transcontinental Gas Pipe Line Company, LLC.
Description: 4(d) Rate Filing; 2024 Annual Transco Fuel Tracker to be effective 4/1/2024.
Filed Date: 2/29/24.
Accession Number: 20240229-5161.
Comment Date: 5 p.m. ET 3/12/24.
Docket Numbers: RP24-460-000.
Applicants: Northwest Pipeline LLC.
Description: 4(d) Rate Filing; North Seattle and South Seattle Annual Charges Update Filing 2024 to be effective 4/1/2024.
Filed Date: 2/29/24.
Accession Number: 20240229-5190.
Comment Date: 5 p.m. ET 3/12/24.
Docket Numbers: RP24-461-000.
Applicants: Northwest Pipeline LLC.
Description: 4(d) Rate Filing; 2024 Summer Fuel Filing to be effective 4/1/2024.
Filed Date: 2/29/24.
Accession Number: 20240229-5193.
Comment Date: 5 p.m. ET 3/12/24.
Docket Numbers: RP24-462-000.
Applicants: Columbia Gas Transmission, LLC.
Description: 4(d) Rate Filing; EPCA 2024 to be effective 4/1/2024.
Filed Date: 2/29/24.
Accession Number: 20240229-5226.
Comment Date: 5 p.m. ET 3/12/24.
Docket Numbers: RP24-463-000.
Applicants: Columbia Gas Transmission, LLC.
Description: 4(d) Rate Filing; TCRA 2024 to be effective 4/1/2024.
Filed Date: 2/29/24.
Accession Number: 20240229-5227.
Comment Date: 5 p.m. ET 3/12/24.
Docket Numbers: RP24-464-000.
Applicants: Columbia Gas Transmission, LLC.
Description: 4(d) Rate Filing; RAM 2024 to be effective 4/1/2024.
Filed Date: 2/29/24.
Accession Number: 20240229-5228.
Comment Date: 5 p.m. ET 3/12/24.
Docket Numbers: RP24-465-000.
Applicants: El Paso Natural Gas Company, L.L.C.
Description: 4(d) Rate Filing; Negotiated Rate Agreements Update (Pioneer Mar 2024) to be effective 3/1/2024.
Filed Date: 2/29/24.
Accession Number: 20240229-5232.
Comment Date: 5 p.m. ET 3/12/24.
Docket Numbers: RP24-466-000.
Applicants: Columbia Gulf Transmission, LLC.
Description: 4(d) Rate Filing; TRA 2024 to be effective 4/1/2024.

Filed Date: 2/29/24.
Accession Number: 20240229–5235.
Comment Date: 5 p.m. ET 3/12/24.
Docket Numbers: RP24–467–000.
Applicants: El Paso Natural Gas Company, L.L.C.

Description: 4(d) Rate Filing: Non-Conforming OPASA Update (SRP) to be effective 4/1/2024.

Filed Date: 2/29/24.
Accession Number: 20240229–5238.
Comment Date: 5 p.m. ET 3/12/24.
Docket Numbers: RP24–468–000.
Applicants: Crossroads Pipeline Company.

Description: 4(d) Rate Filing: TRA 2024 to be effective 4/1/2024.

Filed Date: 2/29/24.
Accession Number: 20240229–5250.
Comment Date: 5 p.m. ET 3/12/24.
Docket Numbers: RP24–469–000.
Applicants: NEXUS Gas Transmission, LLC.

Description: 4(d) Rate Filing: 2024 NEXUS ASA Filing to be effective 4/1/2024.

Filed Date: 2/29/24.
Accession Number: 20240229–5259.
Comment Date: 5 p.m. ET 3/12/24.
Docket Numbers: RP24–470–000.
Applicants: Northern Natural Gas Company.

Description: 4(d) Rate Filing: 20240229 Negotiated Rate to be effective 3/1/2024.

Filed Date: 2/29/24.
Accession Number: 20240229–5260.
Comment Date: 5 p.m. ET 3/12/24.
Docket Numbers: RP24–471–000.
Applicants: Midcontinent Express Pipeline LLC.

Description: 4(d) Rate Filing: Out-Of-Cycle Rate Adjustment Filing 2–29–24 to be effective 4/1/2024.

Filed Date: 2/29/24.
Accession Number: 20240229–5264.
Comment Date: 5 p.m. ET 3/12/24.
Docket Numbers: RP24–472–000.
Applicants: Southern Star Central Gas Pipeline, Inc.

Description: 4(d) Rate Filing: Fuel Filing—Eff. April 1, 2024 to be effective 4/1/2024.

Filed Date: 2/29/24.
Accession Number: 20240229–5274.
Comment Date: 5 p.m. ET 3/12/24.
Docket Numbers: RP24–473–000.
Applicants: Rover Pipeline LLC.

Description: Compliance filing: Rover 2023 AMPS Filing to be effective N/A.

Filed Date: 3/1/24.
Accession Number: 20240301–5006.
Comment Date: 5 p.m. ET 3/13/24.
Docket Numbers: RP24–474–000.
Applicants: Rover Pipeline LLC.
Description: Compliance filing: Flow Through of Cash-Out Penalty Revenues filed on 3–1–24 to be effective N/A.

Filed Date: 3/1/24.
Accession Number: 20240301–5009.
Comment Date: 5 p.m. ET 3/13/24.
Docket Numbers: RP24–475–000.
Applicants: Rover Pipeline LLC.
Description: 4(d) Rate Filing: Fuel Filing on 3–1–24 to be effective 4/1/2024.

Filed Date: 3/1/24.
Accession Number: 20240301–5012.
Comment Date: 5 p.m. ET 3/13/24.
Docket Numbers: RP24–476–000.
Applicants: Panhandle Eastern Pipe Line Company, LP.

Description: 4(d) Rate Filing: Fuel Filing on 3–1–24 to be effective 4/1/2024.

Filed Date: 3/1/24.
Accession Number: 20240301–5028.
Comment Date: 5 p.m. ET 3/13/24.
Docket Numbers: RP24–477–000.
Applicants: High Island Offshore System, L.L.C.

Description: 4(d) Rate Filing: Storm Damage Surcharge 2024 to be effective 4/1/2024.

Filed Date: 3/1/24.
Accession Number: 20240301–5029.
Comment Date: 5 p.m. ET 3/13/24.
Docket Numbers: RP24–478–000.
Applicants: Trunkline Gas Company, LLC.

Description: 4(d) Rate Filing: Fuel Filing on 3–1–24 to be effective 4/1/2024.

Filed Date: 3/1/24.
Accession Number: 20240301–5032.
Comment Date: 5 p.m. ET 3/13/24.
Docket Numbers: RP24–479–000.
Applicants: Florida Gas Transmission Company, LLC.

Description: 4(d) Rate Filing: Fuel Filing on 3–1–24 to be effective 4/1/2024.

Filed Date: 3/1/24.
Accession Number: 20240301–5035.
Comment Date: 5 p.m. ET 3/13/24.
Docket Numbers: RP24–480–000.
Applicants: ETC Tiger Pipeline, LLC.

Description: 4(d) Rate Filing: Fuel Filing Out of Cycle on 3–1–24 to be effective 4/1/2024.

Filed Date: 3/1/24.
Accession Number: 20240301–5039.
Comment Date: 5 p.m. ET 3/13/24.
Docket Numbers: RP24–481–000.
Applicants: Midship Pipeline Company, LLC.

Description: 4(d) Rate Filing: Midship Pipeline Company Fuel Filing to be effective 4/1/2024.

Filed Date: 3/1/24.
Accession Number: 20240301–5056.
Comment Date: 5 p.m. ET 3/13/24.
Docket Numbers: RP24–482–000.
Applicants: WBI Energy Transmission, Inc.

Description: 4(d) Rate Filing: 2024 Annual Fuel & Electric Power Reimbursement Adjustment to be effective 4/1/2024.

Filed Date: 3/1/24.
Accession Number: 20240301–5062.
Comment Date: 5 p.m. ET 3/13/24.
Docket Numbers: RP24–483–000.
Applicants: Cheniere Creole Trail Pipeline, L.P.

Description: 4(d) Rate Filing: Cheniere Creole Trail Annual Fuel Adjustment Filing to be effective 4/1/2024.

Filed Date: 3/1/24.
Accession Number: 20240301–5064.
Comment Date: 5 p.m. ET 3/13/24.
Docket Numbers: RP24–484–000.
Applicants: Cheniere Corpus Christi Pipeline, LP.

Description: 4(d) Rate Filing: Cheniere Corpus Christi Annual Fuel Adjustment Filing to be effective 4/1/2024.

Filed Date: 3/1/24.
Accession Number: 20240301–5072.
Comment Date: 5 p.m. ET 3/13/24.
Docket Numbers: RP24–485–000.
Applicants: High Point Gas Transmission, LLC.

Description: Compliance filing: High Point Gas Annual Fuel Adjustment Filing to be effective N/A.

Filed Date: 3/1/24.
Accession Number: 20240301–5082.
Comment Date: 5 p.m. ET 3/13/24.
Docket Numbers: RP24–486–000.
Applicants: TransCameron Pipeline, LLC.

Description: 4(d) Rate Filing: Normal filing 2024 Annual Fuel Reimbursement filing to be effective 4/1/2024.

Filed Date: 3/1/24.
Accession Number: 20240301–5088.
Comment Date: 5 p.m. ET 3/13/24.
Docket Numbers: RP24–487–000.
Applicants: UGI Mt. Bethel Pipeline Company, LLC.

Description: Annual Retainage Adjustment Mechanism filing for 2023 of UGI Mt. Bethel Pipeline Company, LLC.

Filed Date: 3/1/24.
Accession Number: 20240301–5095.
Comment Date: 5 p.m. ET 3/13/24.
Docket Numbers: RP24–488–000.
Applicants: Midcontinent Express Pipeline LLC.

Description: 4(d) Rate Filing: MEP Cashout Filing March 2024 to be effective 4/1/2024.

Filed Date: 3/1/24.
Accession Number: 20240301–5096.
Comment Date: 5 p.m. ET 3/13/24.
Docket Numbers: RP24–489–000.
Applicants: Maritimes & Northeast Pipeline, L.L.C.

Description: 4(d) Rate Filing: Negotiated Rates—Northern to Emera

Energy 3067 eff 3-1-24 to be effective 3/1/2024.

Filed Date: 3/1/24.

Accession Number: 20240301-5099.

Comment Date: 5 p.m. ET 3/13/24.

Docket Numbers: RP24-490-000.

Applicants: NEXUS Gas

Transmission, LLC.

Description: 4(d) Rate Filing;

Negotiated Rates—Various Releases eff 3-1-2024 to be effective 3/1/2024.

Filed Date: 3/1/24.

Accession Number: 20240301-5101.

Comment Date: 5 p.m. ET 3/13/24.

Docket Numbers: RP24-491-000.

Applicants: Equitrans, L.P.

Description: 4(d) Rate Filing;

Negotiated Rate Capacity Release Agreements- 3/1/2024 to be effective 3/1/2024.

Filed Date: 3/1/24.

Accession Number: 20240301-5104.

Comment Date: 5 p.m. ET 3/13/24.

Docket Numbers: RP24-492-000.

Applicants: MountainWest Pipeline, LLC.

Description: 4(d) Rate Filing: Storage Aquifer Integration to be effective 4/1/2024.

Filed Date: 3/1/24.

Accession Number: 20240301-5107.

Comment Date: 5 p.m. ET 3/13/24.

Docket Numbers: RP24-493-000.

Applicants: Cheniere Corpus Christi Pipeline, LP.

Description: 4(d) Rate Filing: Cheniere Corpus Christi EPC Rate Change to be effective 4/1/2024.

Filed Date: 3/1/24.

Accession Number: 20240301-5113.

Comment Date: 5 p.m. ET 3/13/24.

Docket Numbers: RP24-494-000.

Applicants: Colorado Interstate Gas Company, L.L.C.

Description: 4(d) Rate Filing: CIG Qtrly LUF True-up Feb 2024 to be effective 4/1/2024.

Filed Date: 3/1/24.

Accession Number: 20240301-5127.

Comment Date: 5 p.m. ET 3/13/24.

Docket Numbers: RP24-495-000.

Applicants: East Tennessee Natural Gas, LLC.

Description: 4(d) Rate Filing: Cashout Payment Flexibility Filing to be effective 4/1/2024.

Filed Date: 3/1/24.

Accession Number: 20240301-5130.

Comment Date: 5 p.m. ET 3/13/24.

Docket Numbers: RP24-496-000.

Applicants: El Paso Natural Gas Company, L.L.C.

Description: 4(d) Rate Filing: Non-Conforming Agreement Filing (Mieco) to be effective 4/1/2024.

Filed Date: 3/1/24.

Accession Number: 20240301-5160.

Comment Date: 5 p.m. ET 3/13/24.

Any person desiring to intervene, to protest, or to answer a complaint in any of the above proceedings must file in accordance with Rules 211, 214, or 206 of the Commission's Regulations (18 CFR 385.211, 385.214, or 385.206) on or before 5:00 p.m. Eastern time on the specified comment date. Protests may be considered, but intervention is necessary to become a party to the proceeding.

The filings are accessible in the Commission's eLibrary system (<https://elibrary.ferc.gov/idmws/search/fercensearch.asp>) by querying the docket number.

eFiling is encouraged. More detailed information relating to filing requirements, interventions, protests, service, and qualifying facilities filings can be found at: <http://www.ferc.gov/docs-filing/efiling/filing-req.pdf>. For other information, call (866) 208-3676 (toll free). For TTY, call (202) 502-8659.

The Commission's Office of Public Participation (OPP) supports meaningful public engagement and participation in Commission proceedings. OPP can help members of the public, including landowners, environmental justice communities, Tribal members and others, access publicly available information and navigate Commission processes. For public inquiries and assistance with making filings such as interventions, comments, or requests for rehearing, the public is encouraged to contact OPP at (202) 502-6595 or OPP@ferc.gov.

Dated: March 1, 2024.

Debbie-Anne A. Reese,
Acting Secretary.

[FR Doc. 2024-04908 Filed 3-7-24; 8:45 am]

BILLING CODE 6717-01-P

DEPARTMENT OF ENERGY

Federal Energy Regulatory Commission

[Docket No. CP23-523-000]

ANR Pipeline Company; Notice of Availability of the Environmental Assessment for the Proposed Oak Grove Enhancement Project

The staff of the Federal Energy Regulatory Commission (FERC or Commission) has prepared an environmental assessment (EA) for the Oak Grove Enhancement Project (Project) proposed by ANR Pipeline Company (ANR) in Docket No. CP23-523-000. ANR requests a Certificate of Public Convenience and Necessity pursuant to section 7(c) and

Authorization pursuant to section 7(b) of the Natural Gas Act to construct, operate, and abandon certain natural gas pipeline facilities in Richland and West Carroll Parishes, Louisiana. The proposed Project would include construction of 34.1 miles of new 30-inch-diameter natural gas pipeline to replace 33.6 miles of existing 30-inch-diameter natural gas pipeline. According to ANR, its project would improve the integrity and reliability of ANR's system by replacing vintage pipeline facilities installed in the 1950's with new pipeline facilities.

The EA assesses the potential environmental effects of the construction and operation of the Project in accordance with the requirements of the National Environmental Policy Act (NEPA). The FERC staff concludes that approval of the proposed Project, with appropriate mitigating measures, would not constitute a major Federal action significantly affecting the quality of the human environment.

The Project would consist of the following facilities:

- installation of 34.1 miles of new 30-inch-diameter segment of natural gas pipeline, which will begin at ANR's existing Delhi Compressor Station (CS) in Richland Parish, Louisiana and primarily parallel the existing Line 0-501, 1-501, and 2-501 pipelines before the new segment ties into the existing route just south of State Route 586 in West Carroll Parish, Louisiana.

- Abandonment in place and by removal of 33.6 miles of existing 30-inch-diameter natural gas pipeline, which begins at ANR's existing Delhi CS in Richland Parish and terminates just south of State Route 586 in West Carroll Parish. Approximately one percent (0.25 mile) of the existing Line 0-501 segment would be abandoned by removal, while the remaining existing pipeline segments (totaling 33.35 miles) would be abandoned in place.

- Replacement, modification, and installation of mainline valves and ties-in at existing ANR aboveground facilities.

The Project would not increase or reduce service to any existing ANR customer and no changes to system capacity are proposed. ANR's Project design would allow the existing segment to remain in operation until the replacement pipeline is placed into service.

The Commission mailed a copy of the *Notice of Availability* of the EA to Federal, State, and local government representatives and agencies; elected officials; environmental and public interest groups; Native American Tribes;

potentially affected landowners and other interested individuals and groups; and newspapers and a library in the Project area. The EA is only available in electronic format. It may be viewed and downloaded from the FERC's website (www.ferc.gov), on the natural gas environmental documents page (<https://www.ferc.gov/industries-data/natural-gas/environment/environmental-documents>). In addition, the EA may be accessed by using the eLibrary link on the FERC's website. Click on the eLibrary link (<https://elibrary.ferc.gov/eLibrary/search>), select "General Search" and enter the docket number in the "Docket Number" field, excluding the last three digits (*i.e.*, CP23-523). Be sure you have selected an appropriate date range. For assistance, please contact FERC Online Support at FercOnlineSupport@ferc.gov or toll free at (866) 208-3676, or for TTY, contact (202) 502-8659.

The EA is not a decision document. It presents Commission staff's independent analysis of the environmental issues for the Commission to consider when addressing the merits of all issues in this proceeding. Any person wishing to comment on the EA may do so. Your comments should focus on the EA's disclosure and discussion of potential environmental effects, reasonable alternatives, and measures to avoid or lessen environmental impacts. The more specific your comments, the more useful they will be. To ensure that the Commission has the opportunity to consider your comments prior to making its decision on this project, it is important that we receive your comments in Washington, DC on or before 5 p.m. eastern time on April 1, 2024.

For your convenience, there are three methods you can use to file your comments to the Commission. The Commission encourages electronic filing of comments and has staff available to assist you at (866) 208-3676 or FercOnlineSupport@ferc.gov. Please carefully follow these instructions so that your comments are properly recorded.

(1) You can file your comments electronically using the eComment feature on the Commission's website (www.ferc.gov) under the link to FERC Online. This is an easy method for submitting brief, text-only comments on a project;

(2) You can also file your comments electronically using the eFiling feature on the Commission's website (www.ferc.gov) under the link to FERC Online. With eFiling, you can provide comments in a variety of formats by

attaching them as a file with your submission. New eFiling users must first create an account by clicking on "eRegister." You must select the type of filing you are making. If you are filing a comment on a particular project, please select "Comment on a Filing"; or

(3) You can file a paper copy of your comments by mailing them to the Commission. Be sure to reference the project docket number (CP23-523-000) on your letter. Submissions sent via the U.S. Postal Service must be addressed to: Debbie-Anne A. Reese, Acting Secretary, Federal Energy Regulatory Commission, 888 First Street NE, Room 1A, Washington, DC 20426. Submissions sent via any other carrier must be addressed to: Debbie-Anne A. Reese, Acting Secretary, Federal Energy Regulatory Commission, 12225 Wilkins Avenue, Rockville, MD 20852.

Filing environmental comments will not give you intervenor status, but you do not need intervenor status to have your comments considered. Only intervenors have the right to seek rehearing or judicial review of the Commission's decision. At this point in this proceeding, the timeframe for filing timely intervention requests has expired. Any person seeking to become a party to the proceeding must file a motion to intervene out-of-time pursuant to Rule 214(b)(3) and (d) of the Commission's Rules of Practice and Procedures (18 CFR 385.214(b)(3) and (d)) and show good cause why the time limitation should be waived. Motions to intervene are more fully described at <https://www.ferc.gov/how-intervene>.

Additional information about the project is available from the Commission's Office of External Affairs, at (866) 208-FERC, or on the FERC website (www.ferc.gov) using the eLibrary link. The eLibrary link also provides access to the texts of all formal documents issued by the Commission, such as orders, notices, and rulemakings.

The Commission's Office of Public Participation (OPP) supports meaningful public engagement and participation in Commission proceedings. OPP can help members of the public, including landowners, environmental justice communities, Tribal members and others, access publicly available information and navigate Commission processes. For public inquiries and assistance with making filings such as interventions, comments, or requests for rehearing, the public is encouraged to contact OPP at (202) 502-6595 or OPP@ferc.gov.

In addition, the Commission offers a free service called eSubscription which allows you to keep track of all formal

issuances and submittals in specific dockets. This can reduce the amount of time you spend researching proceedings by automatically providing you with notification of these filings, document summaries, and direct links to the documents. Go to <https://www.ferc.gov/ferc-online/overview> to register for eSubscription.

Dated: March 1, 2024.

Debbie-Anne A. Reese,
Acting Secretary.

[FR Doc. 2024-04910 Filed 3-7-24; 8:45 am]

BILLING CODE 6717-01-P

DEPARTMENT OF ENERGY

Federal Energy Regulatory Commission

[Project No. 2376-000]

Eagle Creek Reusens Hydro, LLC; Notice of Authorization for Continued Project Operation

The license for the Reusens Hydroelectric Project No. 2376 was issued for a period ending February 29, 2024.

Section 15(a)(1) of the FPA, 16 U.S.C. 808(a)(1), requires the Commission, at the expiration of a license term, to issue from year-to-year an annual license to the then licensee(s) under the terms and conditions of the prior license until a new license is issued, or the project is otherwise disposed of as provided in section 15 or any other applicable section of the FPA. If the project's prior license waived the applicability of section 15 of the FPA, then, based on section 9(b) of the Administrative Procedure Act, 5 U.S.C. 558(c), and as set forth at 18 CFR 16.21(a), if the licensee of such project has filed an application for a subsequent license, the licensee may continue to operate the project in accordance with the terms and conditions of the license after the minor or minor part license expires, until the Commission acts on its application. If the licensee of such a project has not filed an application for a subsequent license, then it may be required, pursuant to 18 CFR 16.21(b), to continue project operations until the Commission issues someone else a license for the project or otherwise orders disposition of the project.

If the project is subject to section 15 of the FPA, notice is hereby given that an annual license for Project No. 2376 is issued to Eagle Creek Reusens Hydro, LLC for a period effective March 1, 2024, through February 28, 2025, or until the issuance of a new license for

the project or other disposition under the FPA, whichever comes first.

If issuance of a new license (or other disposition) does not take place on or before February 28, 2025, notice is hereby given that, pursuant to 18 CFR 16.18(c), an annual license under section 15(a)(1) of the FPA is renewed automatically without further order or notice by the Commission, unless the Commission orders otherwise.

If the project is not subject to section 15 of the FPA, notice is hereby given that Eagle Creek Reusens Hydro, LLC is authorized to continue operation of the Reusens Hydroelectric Project under the terms and conditions of the prior license until the issuance of a subsequent license for the project or other disposition under the FPA, whichever comes first.

Dated: March 1, 2024.

Debbie-Anne A. Reese,
Acting Secretary.

[FR Doc. 2024-04917 Filed 3-7-24; 8:45 am]

BILLING CODE 6717-01-P

DEPARTMENT OF ENERGY

Federal Energy Regulatory Commission

Combined Notice of Filings #1

Take notice that the Commission received the following exempt wholesale generator filings:

Docket Numbers: EG24-127-000.

Applicants: Bartonsville Energy Facility, LLC.

Description: Bartonsville Energy Facility, LLC submits Notice of Self-Certification of Exempt Wholesale Generator Status.

Filed Date: 3/1/24.

Accession Number: 20240301-5231.

Comment Date: 5 p.m. ET 3/22/24.

Take notice that the Commission received the following electric rate filings:

Docket Numbers: ER12-1561-005; ER15-1348-003; ER13-823-008; ER17-424-010.

Applicants: Footprint Power Salem Harbor Development LP, Castleton Commodities Merchant Trading L.P., Roseton Generating LLC, LDH Rensselaer LLC.

Description: Supplement to June 30, 2023, Triennial Market Power Analysis for Northeast Region of Rensselaer Generating LLC, et al.

Filed Date: 2/29/24.

Accession Number: 20240229-5345.

Comment Date: 5 p.m. ET 3/21/24.

Docket Numbers: ER24-1376-000.

Applicants: Yuma Solar Energy LLC.

Description: Baseline eTariff Filing: Application for Market Based Rate to be effective 3/1/2024.

Filed Date: 2/29/24.

Accession Number: 20240229-5303.

Comment Date: 5 p.m. ET 3/21/24.

Docket Numbers: ER24-1377-000.

Applicants: Midcontinent

Independent System Operator, Inc.

Description: 205(d) Rate Filing: 2024-03-01 Credit Policy and Related Tariff Revisions to be effective 5/1/2024.

Filed Date: 3/1/24.

Accession Number: 20240301-5068.

Comment Date: 5 p.m. ET 3/22/24.

Docket Numbers: ER24-1378-000.

Applicants: Midcontinent

Independent System Operator, Inc.,

Ameren Services Company.

Description: 205(d) Rate Filing: Midcontinent Independent System Operator, Inc. submits tariff filing per 35.13(a)(2)(iii): 2024-03-01 4248

Ameren Missouri-Ameren Missouri E&P (Castle Bluff) to be effective 3/2/2024.

Filed Date: 3/1/24.

Accession Number: 20240301-5069.

Comment Date: 5 p.m. ET 3/22/24.

Docket Numbers: ER24-1379-000.

Applicants: PJM Interconnection, L.L.C.

Description: 205(d) Rate Filing: Amendment to ISA, SA No. 1848; Queue No. O38 to be effective 3/2/2024.

Filed Date: 3/1/24.

Accession Number: 20240301-5075.

Comment Date: 5 p.m. ET 3/22/24.

Docket Numbers: ER24-1380-000.

Applicants: PJM Interconnection, L.L.C.

Description: 205(d) Rate Filing: Amendment to ISA, SA No. 2078; Queue No. P22 to be effective 3/2/2024.

Filed Date: 3/1/24.

Accession Number: 20240301-5076.

Comment Date: 5 p.m. ET 3/22/24.

Docket Numbers: ER24-1381-000.

Applicants: Entergy Louisiana, LLC.

Description: Tariff Amendment: ELL-SRMPA PRA Termination to be effective 2/29/2024.

Filed Date: 3/1/24.

Accession Number: 20240301-5109.

Comment Date: 5 p.m. ET 3/22/24.

Docket Numbers: ER24-1382-000.

Applicants: Horus Louisiana 1, LLC.

Description: Baseline eTariff Filing:

HORUS Louisiana 1, LLC MBR

Application Filing to be effective 4/1/2024.

Filed Date: 3/1/24.

Accession Number: 20240301-5135.

Comment Date: 5 p.m. ET 3/22/24.

Docket Numbers: ER24-1383-000.

Applicants: Duke Energy Florida,

LLC.

Description: 205(d) Rate Filing: DEF-SECI-SEPA Dynamic Transfer Agmt RS No. 428 to be effective 5/1/2024.

Filed Date: 3/1/24.

Accession Number: 20240301-5157.

Comment Date: 5 p.m. ET 3/22/24.

Docket Numbers: ER24-1384-000.

Applicants: Tampa Electric Company.

Description: Compliance filing: Compliance Filing—FERC Order 2023 to be effective 5/1/2024.

Filed Date: 3/1/24.

Accession Number: 20240301-5175.

Comment Date: 5 p.m. ET 3/22/24.

Docket Numbers: ER24-1385-000.

Applicants: PacifiCorp.

Description: 205(d) Rate Filing: Construction Agreement Barnes Butte to be effective 5/1/2024.

Filed Date: 3/1/24.

Accession Number: 20240301-5182.

Comment Date: 5 p.m. ET 3/22/24.

Docket Numbers: ER24-1386-000.

Applicants: Bartonsville Energy

Facility, LLC.

Description: Baseline eTariff Filing:

Application for Market-Based Rate

Authority to be effective 4/29/2024.

Filed Date: 3/1/24.

Accession Number: 20240301-5213.

Comment Date: 5 p.m. ET 3/22/24.

Docket Numbers: ER24-1387-000.

Applicants: PJM Interconnection,

L.L.C.

Description: 205(d) Rate Filing: Revisions to Schedule Selection in Day-Ahead Energy Market to be effective 5/1/2024.

Filed Date: 3/1/24.

Accession Number: 20240301-5215.

Comment Date: 5 p.m. ET 3/22/24.

Docket Numbers: ER24-1388-000.

Applicants: Consolidated Edison

Company of New York, Inc.

Description: 205(d) Rate Filing: 89

IEDR Phase 2 on 3-1-2024 to be

effective 3/1/2024.

Filed Date: 3/1/24.

Accession Number: 20240301-5234.

Comment Date: 5 p.m. ET 3/22/24.

Docket Numbers: ER24-1389-000.

Applicants: Arizona Public Service

Company.

Description: 205(d) Rate Filing: Rate Schedule No. 319, NWPP Certificate of Concurrence to be effective 5/1/2024.

Filed Date: 3/1/24.

Accession Number: 20240301-5239.

Comment Date: 5 p.m. ET 3/22/24.

Docket Numbers: ER24-1390-000.

Applicants: Five Elements Energy II

LLC.

Description: Baseline eTariff Filing:

Baseline new to be effective 3/2/2024.

Filed Date: 3/1/24.

Accession Number: 20240301-5249.

Comment Date: 5 p.m. ET 3/22/24.

The filings are accessible in the Commission's eLibrary system (<https://elibrary.ferc.gov/idmws/search/>)

fercgensearch.asp) by querying the docket number.

Any person desiring to intervene, to protest, or to answer a complaint in any of the above proceedings must file in accordance with Rules 211, 214, or 206 of the Commission's Regulations (18 CFR 385.211, 385.214, or 385.206) on or before 5:00 p.m. Eastern time on the specified comment date. Protests may be considered, but intervention is necessary to become a party to the proceeding.

eFiling is encouraged. More detailed information relating to filing requirements, interventions, protests, service, and qualifying facilities filings can be found at: <http://www.ferc.gov/docs-filing/efiling/filing-req.pdf>. For other information, call (866) 208-3676 (toll free). For TTY, call (202) 502-8659.

The Commission's Office of Public Participation (OPP) supports meaningful public engagement and participation in Commission proceedings. OPP can help members of the public, including landowners, environmental justice communities, Tribal members and others, access publicly available information and navigate Commission processes. For public inquiries and assistance with making filings such as interventions, comments, or requests for rehearing, the public is encouraged to contact OPP at (202) 502-6595 or OPP@ferc.gov.

Dated: March 1, 2024.

Debbie-Anne A. Reese,
Acting Secretary.

[FR Doc. 2024-04912 Filed 3-7-24; 8:45 am]

BILLING CODE 6717-01-P

DEPARTMENT OF ENERGY

Federal Energy Regulatory Commission

[Project No. 2614-042]

City of Hamilton, Ohio and American Municipal Power, Inc.; Notice of Application Tendered for Filing With the Commission and Soliciting Additional Study Requests and Establishing Procedural Schedule for Relicensing and a Deadline for Submission of Final Amendments

Take notice that the following hydroelectric application has been filed with the Commission and is available for public inspection.

a. *Type of Application:* New Major License.

b. *Project No.:* 2614-042.

c. *Date Filed:* February 21, 2024.

d. *Submitted By:* City of Hamilton, Ohio (City of Hamilton) and American

Municipal Power, Inc. (American Power).

e. *Name of Project:* Greenup Hydroelectric Project (Greenup Project).

f. *Location:* The Greenup Project is located at the U.S. Army Corps of Engineers' (Corps) Greenup Locks and Dam on the Ohio River near the Town of Franklin Furnace in Scioto County, Ohio and Greenup County, Kentucky. The project occupies 12.74 acres of federal land administered by the Corps.

g. *Filed Pursuant to:* Federal Power Act 16 U.S.C. 791(a)-825(r).

h. *Applicant Contact:* Jeff Martin, City of Hamilton, Ohio, 9505 West Mary Ingles Highway (KY Route 8), Foster, KY 41043; (606) 747-6103; greenuplicensing@hamilton-oh.gov.

John McGreevy, American Municipal Power, Inc. 1111 Schrock Road Columbus, OH 43229; (614) 540-1111; greenuplicensing@hamilton-oh.gov.

i. *FERC Contact:* Twyla Cheatwood at (202) 502-8066; or email at twyla.cheatwood@ferc.gov.

j. *Cooperating Agencies:* Federal, state, local, and tribal agencies with jurisdiction and/or special expertise with respect to environmental issues that wish to cooperate in the preparation of the environmental document should follow the instructions for filing such requests described in item l below. Cooperating agencies should note the Commission's policy that agencies that cooperate in the preparation of the environmental document cannot also intervene. *See*, 94 FERC ¶ 61,076 (2001).

k. Pursuant to section 4.32(b)(7) of 18 CFR of the Commission's regulations, if any resource agency, Indian Tribe, or person believes that an additional scientific study should be conducted in order to form an adequate factual basis for a complete analysis of the application on its merit, the resource agency, Indian Tribe, or person must file a request for a study with the Commission not later than 60 days from the date of filing of the application, and serve a copy of the request on the applicant.

l. Deadline for filing additional study requests and requests for cooperating agency status: April 21, 2024.¹

The Commission strongly encourages electronic filing. Please file additional study requests and requests for

¹ The Commission's Rules of Practice and Procedure provide that if a filing deadline falls on a Saturday, Sunday, holiday, or other day when the Commission is closed for business, the filing deadline does not end until the close of business on the next business day. 18 CFR 385.2007(a)(2). Because the 60-day filing deadline falls on a Sunday (*i.e.*, April 21, 2024), the filing deadline is extended until the close of business on Monday, April 22, 2024.

cooperating agency status using the Commission's eFiling system at <http://www.ferc.gov/docs-filing/efiling.asp>. For assistance, please contact FERC Online Support at FERCOnlineSupport@ferc.gov, (866) 208-3676 (toll free), or (202) 502-8659 (TTY). In lieu of electronic filing, you may submit a paper copy. Submissions sent via the U.S. Postal Service must be addressed to: Debbie-Anne A. Reese, Acting Secretary, Federal Energy Regulatory Commission, 888 First Street NE, Room 1A, Washington, DC 20426. Submissions sent via any other carrier must be addressed to: Debbie-Anne A. Reese, Acting Secretary, Federal Energy Regulatory Commission, 12225 Wilkins Avenue, Rockville, Maryland 20852. All filings must clearly identify the project name and docket number on the first page: Greenup Hydroelectric Project (P-2614-042).

m. The application is not ready for environmental analysis at this time.

n. The Greenup Project uses the Corps' existing Greenup Locks and Dam and consist of the following existing facilities: (1) a 125-foot-long, 145-foot-wide reinforced concrete intake channel with sloped bottom; (2) three 39-foot-wide intakes equipped with trashracks having a clear bar spacing of 5.9 inches; (3) a 145-foot-wide and 190-foot-long powerhouse consisting of a steel-plate enclosure with concrete filled bulkhead walls located on the east (right) end of the dam, with a combined capacity of 70.27 megawatts; (4) a 125-foot-long and 145-foot-wide reinforced concrete tailrace channel with sloped bottom; (5) a 10-foot-wide gravity dam between the powerhouse and gated spillway which acts as an uncontrolled spillway during open river (flood) conditions; and (6) a steel sheet pile wall that stabilizes the right (east) bank.

The Greenup Project currently operates in a run-of-release mode using flows released by the Corps, and has an estimated average annual energy production of 263,596 megawatt-hours. City of Hamilton and American Power do not propose any new construction and propose to continue operating the project in a run-of-release mode.

o. Copies of the application may be viewed on the Commission's website at <http://www.ferc.gov> using the "eLibrary" link. Enter the docket number, excluding the last three digits in the docket number field to access the document (P-2535). For assistance, contact FERC Online Support at FERCOnlineSupport@ferc.gov, or call (866) 208-3676 (toll-free) or (202) 502-8659 (TTY).

You may also register online at <http://www.ferc.gov/docs-filing/>

esubscription.asp to be notified via email of new filings and issuances related to this or other pending projects. For assistance, contact FERC Online Support.

p. The Commission’s Office of Public Participation (OPP) supports meaningful public engagement and participation in Commission proceedings. OPP can help members of the public, including landowners, environmental justice communities, Tribal members and others, access publicly available information and navigate Commission processes. For public inquiries and assistance with making filings such as interventions, comments, or requests for rehearing, the public is encouraged to contact OPP at (202) 502–6595, or *OPP@ferc.gov*.

q. Procedural schedule and final amendments: the application will be processed according to the following preliminary schedule. Revisions to the schedule will be made as appropriate.

Milestone	Target date
Issue Deficiency Letter (if necessary).	May 2024.
Request Additional Information (if necessary).	May 2024.
Issue Scoping Document 1 for comments.	August 2024.
Request Additional Information (if necessary).	October 2024.
Issue Scoping Document 2 (if necessary).	November 2024.

Final amendments to the application must be filed with the Commission no later than 30 days from the issuance date of the notice of ready for environmental analysis.

Dated: March 1, 2024.

Debbie-Anne A. Reese,
Acting Secretary.

[FR Doc. 2024–04915 Filed 3–7–24; 8:45 am]

BILLING CODE 6717–01–P

ENVIRONMENTAL PROTECTION AGENCY

[FRL–11771–01–OA]

Request for Nominations to the EPA Science Advisory Board

AGENCY: Environmental Protection Agency (EPA).

ACTION: Notice.

SUMMARY: The U.S. Environmental Protection Agency (EPA) invites nominations of scientific experts from a diverse range of disciplines to be considered for appointment to the EPA Science Advisory Board (SAB).

DATES: Nominations should be submitted in time to arrive no later than April 8, 2024.

FOR FURTHER INFORMATION CONTACT: For information about the chartered SAB membership, appointment process, and schedule, please contact Dr. Suhair Shallal, DFO, by telephone at (202) 564–2057, or by email at *shallal.suhair@epa.gov* or Dr. Thomas Armitage, DFO, by telephone at (202) 564–2155, or by email at *armitage.thomas@epa.gov*.

SUPPLEMENTARY INFORMATION:

Background: The SAB is a chartered Federal Advisory Committee, established in 1978 under the authority of the Environmental Research, Development and Demonstration Authorization Act (ERDDAA), codified at 42 U.S.C. 4365, to provide independent scientific and technical peer review, consultation, advice, and recommendations to the EPA Administrator on the scientific bases for EPA’s actions and programs. Members of the SAB constitute distinguished bodies of non-EPA scientists, engineers, economists, and behavioral scientists who are nationally and internationally recognized experts in their respective fields. Members are appointed by the EPA Administrator for a two or three-year term and serve as Special Government Employees who provide independent expert advice to the agency. All the work of SAB committees and ad-hoc panels is conducted under the auspices of the chartered SAB. Additional information is available at <https://sab.epa.gov>.

Expertise Sought for the SAB: The SAB Staff Office invites nominations of individuals to serve on the chartered SAB with expertise or extensive experience in the following scientific disciplines and topics as they relate to human health and the environment: *air quality; agricultural sciences and economics; analytical chemistry; atmospheric sciences; benefit-cost analysis; chemical safety; climate science; citizen science; community environmental health; dose-response assessment; drinking water; drinking water engineering; ecological sciences and ecological assessment; ecological risk assessment; ecosystem services; economics; energy and the environment; engineering; environmental justice; epidemiology; exposure assessment; forestry; geochemistry; health sciences; human health risk assessment; hydrology; hydrogeology; medicine; microbiology; modeling; pediatrics; pesticide risk assessment, public health; physiologically based pharmacokinetic (PBPK) modeling; risk assessment; social, behavioral and decision sciences;*

statistics; sustainability; radiological risk assessment; toxicology; uncertainty analysis; water quality; water quantity and reuse; and waste management.

Members selected to the chartered SAB may also participate on standing committees of the SAB. Board members with demonstrated scientific credentials, disciplinary expertise in relevant fields, and experience may be asked to participate on one of the following SAB Standing Committees:

- The Agricultural Science Committee, which provides advice to the chartered SAB on matters that have been determined to have a significant direct impact on farming and agriculture-related industries.
 - The Chemical Assessment Advisory Committee, which provides advice to the chartered SAB regarding selected toxicological reviews of environmental chemicals.
 - The Climate Science Committee, which provides advice to the chartered SAB on climate change science and the effects of climate change.
 - The Drinking Water Committee, which provides advice to the chartered SAB on the scientific and technical aspects of EPA’s national drinking water program.
 - The Economic Analysis Committee, which provides advice to the chartered SAB on the economic analysis of EPA programs.
 - The Environmental Justice Science Committee, which provides advice to the chartered SAB on the scientific and technical aspects of environmental justice to improve the environment and/or public health in communities disproportionately impacted by environmental health hazards and risks.
 - The Radiation Advisory Committee, which provides advice to the chartered SAB on radiation protection, radiation science, and radiation risk assessment.
- Selection Criteria for the SAB and the SAB Committees include:*
- Demonstrated scientific credentials and disciplinary expertise in relevant fields;
 - Willingness to commit time to the committee and demonstrated ability to work constructively and effectively on committees;
 - Background and experiences that would help members contribute to the diversity of perspectives on the committee, e.g., geographical, social, cultural, educational backgrounds, professional affiliations; and other considerations; and
 - For the committee, the collective breadth and depth of scientific expertise are considered.
- As the SAB and its standing committees undertake specific advisory

activities, the SAB Staff Office will consider two additional criteria for each new activity: absence of financial conflicts of interest and absence of an appearance of a loss of impartiality.

How to Submit Nominations: Any interested person or organization may nominate qualified persons to be considered for appointment to these advisory

committees. Individuals may self-nominate. Nominations should be submitted in electronic format (preferred) using the online nomination form under the heading “Committees, Panels, and Membership” at the bottom of the SAB home page at <https://sab.epa.gov>. To be considered, all nominations should include the information requested below. EPA values and welcomes diversity. All qualified candidates are encouraged to apply regardless of gender, race, disability, or ethnicity.

The following information should be provided on the nomination form: contact information for the person making the nomination; contact information for the nominee; the disciplinary and specific areas of expertise of the nominee; the nominee’s *curriculum vitae*; and a biographical sketch of the nominee indicating current position, educational background; research activities; sources of research funding for the last two years; and recent service on other national advisory committees or national professional organizations. To help the agency evaluate the effectiveness of its outreach efforts, please indicate how you learned of this nomination opportunity. Persons having questions about the nomination process or the public comment process described below, or those who are unable to submit nominations through the SAB website, should contact the DFO, as identified above. The DFO will acknowledge receipt of nominations and in that acknowledgment, will invite the nominee to provide any additional information that the nominee feels would be useful in considering the nomination, such as availability to participate as a member of the committee; how the nominee’s background, skills, and experience would contribute to the diversity of the committee; and any questions the nominee has regarding membership. The names and biosketches of qualified nominees identified by respondents to this **Federal Register** notice, and any additional experts identified by the SAB Staff Office, will be posted in a List of Candidates on the SAB website at <https://sab.epa.gov>. Public comments on each List of Candidates will be

accepted for 21 days from the date the list is posted. The public will be requested to provide relevant information or other documentation on nominees that the SAB Staff Office should consider in evaluating candidates.

Candidates invited to serve will be asked to submit the “Confidential Financial Disclosure Form for Special Government Employees Serving on Federal Advisory Committees at the U.S. Environmental Protection Agency” (EPA Form 3110–48). This confidential form allows EPA to determine whether there is a statutory conflict between that person’s public responsibilities as a Special Government Employee and private interests and activities, or the appearance of a loss of impartiality, as defined by Federal regulation. The form may be viewed and downloaded through the “Ethics Requirements for Advisors” link on the SAB home page at <https://sab.epa.gov>. This form should not be submitted as part of a nomination.

V Khanna Johnston,
Deputy Director, Science Advisory Board Staff Office.

[FR Doc. 2024–04941 Filed 3–7–24; 8:45 am]

BILLING CODE 6560–50–P

ENVIRONMENTAL PROTECTION AGENCY

[FRL OP–OFA–114]

Environmental Impact Statements; Notice of Availability

Responsible Agency: Office of Federal Activities, General Information 202–564–5632 or <https://www.epa.gov/nepa>. Weekly receipt of Environmental Impact Statements (EIS) Filed February 26, 2024 10 a.m. EST Through March 4, 2024 10 a.m. EST Pursuant to 40 CFR 1506.9.

Notice

Section 309(a) of the Clean Air Act requires that EPA make public its comments on EISs issued by other Federal agencies. EPA’s comment letters on EISs are available at: <https://cdxapps.epa.gov/cdx-enepa-II/public/action/eis/search>.

EIS No. 20240037, Draft, DOE, NAT, Department of Energy Activities in Support of Commercial Production of High-Assay Low-Enriched Uranium (HALEU), Comment Period Ends: 04/22/2024, Contact: James Lovejoy 208–526–6805.

EIS No. 20240038, Draft, BLM, USFS, UT, Bears Ears National Monument Draft Resource Management Plan,

Comment Period Ends: 06/11/2024, Contact: Jill Stephenson 435–259–2141.

EIS No. 20240039, Final Supplement, BR, CO, Near-term Colorado River Operations Final Supplemental EIS, Review Period Ends: 04/08/2024, Contact: Genevieve Johnson 702–293–8054.

Dated: March 5, 2024.

Cindy S. Barger,
Director, NEPA Compliance Division, Office of Federal Activities.

[FR Doc. 2024–04957 Filed 3–7–24; 8:45 am]

BILLING CODE 6560–50–P

ENVIRONMENTAL PROTECTION AGENCY

[FRL–11586–01–OW]

Deepwater Horizon Natural Resource Damage Assessment Florida Trustee Implementation Group Draft Restoration Plan 3 and Environmental Assessment: Water Quality

AGENCY: Environmental Protection Agency (EPA).

ACTION: Notice of availability; request for public comments.

SUMMARY: The Deepwater Horizon natural resource Trustees for the Florida Trustee Implementation Group have prepared the Draft Restoration Plan 3 and Environmental Assessment: Water Quality. The Draft RP3/EA proposes alternatives to help restore water quality impacted by the DWH oil spill. The Draft RP3/EA evaluates a reasonable range of thirteen project alternatives under the Oil Pollution Act, including criteria set forth in the OPA natural resource damage assessment regulations, and the National Environmental Policy Act and its implementing regulations. A no action alternative is also evaluated pursuant to the NEPA. The total estimated cost to implement the Florida TIG’s eleven preferred alternatives is approximately \$111.5 million. The Florida TIG invites the public to comment on the Draft RP3/EA.

DATES: The Florida TIG will consider public comments on the Draft RP3/EA received on or before April 8, 2024.

Public Webinar: The Florida TIG will host a public webinar on March 27, 2024, at 3 p.m. Eastern Time/2 p.m. Central Time to facilitate public review and comment on the Draft RP3/EA. The public may register for the webinar at <https://attendee.gotowebinar.com/register/8172353705750284118>. After registering, participants will receive a confirmation email with instructions for

joining the webinar and how to make comments during the webinar. Shortly after the webinar concludes, the presentation material will be posted on the web at <https://www.gulfspillrestoration.noaa.gov/restoration-areas/florida>.

ADDRESSES: Obtaining Documents: You may view and download the Draft RP3/EA at <https://www.gulfspillrestoration.noaa.gov/restoration-areas/florida>. You may also request a flash drive containing the Draft RP3/EA (see **FOR FURTHER INFORMATION CONTACT**).

Submitting Comments: You may submit comments on the Draft RP3/EA by any of the following methods:

- **Website:** <https://parkplanning.nps.gov/FLTIGRP3>. Follow the online instructions for submitting comments.

- **Mail:** U.S. Fish and Wildlife Service Gulf Restoration Office, 1875 Century Blvd., Atlanta, GA 30345. To be considered, mailed comments must be postmarked on or before the comment deadline given in **DATES**.

- **Public Webinar:** The public may submit comments during the webinar. Webinar information is provided in **DATES**.

Instructions: Once submitted, comments cannot be edited or withdrawn. The Florida TIG may publish any comment received regarding the document. Do not submit electronically any information you consider to be Confidential Business Information or other information whose disclosure is restricted by statute. Please be aware that your entire comment, including your personal identifying information, will become part of the public record.

FOR FURTHER INFORMATION CONTACT:

Sarah Ketron; Florida Department of Environmental Protection; 850–245–2167; Sarah.Ketron@FloridaDEP.gov.

Tripp Boone; Environmental Protection Agency; 228–209–7555; Boone.Tripp@epa.gov.

SUPPLEMENTARY INFORMATION:

Introduction

On April 20, 2010, the mobile offshore drilling unit Deepwater Horizon, which was drilling a well for BP Exploration and Production, Inc., experienced a significant explosion, fire and subsequent sinking in the Gulf of Mexico, resulting in the release of millions of barrels of oil and other discharges into the Gulf. Under the authority of the OPA, designated Federal and State Trustees, acting on behalf of the public, assessed the injuries to natural resources and

prepared the Deepwater Horizon Oil Spill Final Programmatic Damage Assessment and Restoration Plan and Final Programmatic Environmental Impact Statement, and the Record of Decision for the Deepwater Horizon Oil Spill Final Programmatic Damage Assessment and Restoration Plan and Final Programmatic Environmental Impact Statement, which sets forth the governance structure and process for DWH restoration planning under the OPA NRDA regulations. On April 4, 2016, the United States District Court for the Eastern District of Louisiana entered a Consent Decree resolving civil claims by the Trustees against BP.

The Florida TIG, which is composed of the State of Florida Department of Environmental Protection and the Fish and Wildlife Conservation Commission, the U.S. Department of the Interior, the National Oceanic and Atmospheric Administration, and the U.S. Department of Agriculture, selects and implements restoration projects under the TIG's management authority in accordance with the Consent Decree. The Final PDARP/PEIS, ROD, Consent Decree, and information on the DWH Trustees can be found at <https://www.gulfspillrestoration.noaa.gov/restoration-planning/gulf-plan>.

Background

On November 7, 2022, the Florida TIG issued a notice of solicitation on the Gulf Spill Restoration website requesting project ideas for the Water Quality Restoration Type as described in the Final PDARP/PEIS. On August 7, 2023, the TIG announced on the Gulf Spill Restoration website that they reviewed project idea submissions and initiated drafting the RP3/EA which tiers from the Final PDARP/PEIS and would include a reasonable range of restoration project alternatives for the Water Quality Restoration Type.

Overview of the Florida TIG Draft RP3/EA

In the Draft RP3/EA, the Florida TIG analyzes a reasonable range of thirteen project alternatives and, pursuant to the NEPA, a no action alternative. Two of the alternatives analyzed are not preferred by the TIG at this time. Funding to implement any of the alternatives ultimately selected by the Florida TIG would come from the Water Quality Restoration Type Allocation. The reasonable range of project alternatives evaluated by the TIG are listed below:

1. Pensacola and Perdido Watersheds Microbial Source Tracking (Planning);

2. Pensacola Bay Unpaved Roads Initiative Phase 2 (Planning);

3. Carpenter Creek Hydrologic Restoration and Stormwater Improvements;

4. Hollice T. Williams Stormwater Park;

5. Gulf Breeze Septic to Sewer Conversion;

6. Santa Rosa County Septic to Sewer Conversion;

7. Choctawhatchee Bay Unpaved Roads Initiative;

8. Telogia Creek Watershed Water Quality Improvements;

9. Lower Suwannee National Wildlife Refuge Hydrologic Restoration Phase 2 (Planning);

10. Bond Farm Hydrologic Enhancement Impoundment;

11. Bond Farm Hydrologic Enhancement Southwest Discharge Structure (Planning);

12. Swift Creek Hydrologic Restoration (Non-preferred); and

13. Springfield Stream and Wetland Enhancement (Non-preferred).

The total estimated cost to implement the eleven preferred alternatives is approximately \$111.5 million.

Next Steps

After the public comment period ends, the Florida TIG will consider and address all substantive comments received before making a final decision on which, if any, alternatives to fund and implement. A Final RP3/EA and finding of no significant impact, as appropriate, identifying the selected alternatives will be made publicly available.

Administrative Record

The Administrative Record for the Draft RP3/EA can be viewed electronically at <https://www.doi.gov/deepwaterhorizon/adminrecord> under the folder 6.5.4.2.

Authority

The authority for this action is the Oil Pollution Act of 1990 (33 U.S.C. 2701 *et seq.*), its implementing NRDA regulations found at 15 CFR part 990, and the National Environmental Policy Act of 1969 (42 U.S.C. 4321 *et seq.*), its implementing regulations found at 40 CFR parts 1500–1508.

Benita Best-Wong,

Deputy Assistant Administrator.

[FR Doc. 2024–04727 Filed 3–7–24; 8:45 am]

BILLING CODE 6560–50–P

FEDERAL ACCOUNTING STANDARDS ADVISORY BOARD**Notice of Request for Comment on an Exposure Draft Titled Seized and Forfeited Digital Assets**

AGENCY: Federal Accounting Standards Advisory Board.

ACTION: Notice.

SUMMARY: Notice is hereby given that the Federal Accounting Standards Advisory Board (FASAB) staff has released for public comment an exposure draft of a proposed Technical Bulletin titled *Seized and Forfeited Digital Assets*. Respondents are encouraged to comment on any part of the exposure draft.

DATES: Written comments are requested by April 18, 2024.

ADDRESSES: The exposure draft is available on the FASAB website at <https://www.fasab.gov/documents-for-comment/>. Copies can be obtained by contacting FASAB at (202) 512-7350. Comments should be sent to fasab@fasab.gov.

FOR FURTHER INFORMATION CONTACT: Ms. Monica R. Valentine, Executive Director, 441 G Street NW, Suite 1155, Washington, DC 20548, or call (202) 512-7350.

Authority: 31 U.S.C. 3511(d); Federal Advisory Committee Act, 5 U.S.C. 1001-1014

Dated: March 5, 2024.

Monica R. Valentine,
Executive Director.

[FR Doc. 2024-04967 Filed 3-7-24; 8:45 am]

BILLING CODE 1610-02-P

FEDERAL COMMUNICATIONS COMMISSION**Federal Advisory Committee Act; Technological Advisory Council**

AGENCY: Federal Communications Commission.

ACTION: Notice of public meeting.

SUMMARY: In accordance with the Federal Advisory Committee Act, this notice advises interested persons that the Federal Communications Commission's (FCC) Chairwoman Jessica Rosenworcel has appointed members to serve on the Technological Advisory Council (TAC) and will hold a meeting.

DATES: Tuesday, March 19th, 2024 in the Commission Meeting Room, beginning at 10 a.m., eastern time.

ADDRESSES: Federal Communications Commission, 45 L Street NE, Washington, DC 20554.

FOR FURTHER INFORMATION CONTACT: Martin Doczkat, Designated Federal Official, 202-418-2435; Martin.Doczkat@FCC.gov.

SUPPLEMENTARY INFORMATION: At the March 19th meeting, the FCC will attempt to accommodate as many people as possible. While the TAC meeting is open to the public, the FCC headquarters building is not open access, and all guests must check in with and be screened by FCC security at the main entrance. Attendees are not required to have an appointment, but must otherwise comply with protocols outlined at: <https://www.fcc.gov/visit>.

Meetings are also broadcast live with open captioning over the internet from the FCC Live web page at <http://www.fcc.gov/live/>. The public may submit written comments before the meeting to: Martin Doczkat, the FCC's Designated Federal Officer for Technological Advisory Council by email: Martin.Doczkat@fcc.gov or U.S. Postal Service Mail (Martin Doczkat, Federal Communications Commission, 45 L Street NE, Washington, DC 20554). Open captioning will be provided for this event. Other reasonable accommodations for people with disabilities are available upon request. Requests for such accommodations should be submitted via email to fcc504@fcc.gov or by calling the Office of Engineering and Technology at 202-418-2470 (voice), (202) 418-1944 (fax). Such requests should include a detailed description of the accommodation needed. In addition, please include your contact information. Please allow at least five days advance notice; last minute requests will be accepted, but may not be possible to fill.

Synopsis

The Public Notice serves as notice that, consistent with the Federal Advisory Committee Act, Federal Communications Commission (FCC or Commission) Chairwoman Jessica Rosenworcel has appointed members to serve on TAC. The TAC is comprised of a diverse group of leading technology experts. Dean Brenner, a former executive at Qualcomm, serves as Chairman of the Council. Martin Doczkat, Chief of the Electromagnetic Compatibility Division in the Office of Engineering and Technology, serves as the Designated Federal Officer. Sean Yun, Deputy Chief of the Electromagnetic Compatibility Division in the Office of Engineering and

Technology, is the Alternate Designated Federal Officer.

Federal Communications Commission.

Ronald T. Repasi,
Chief, Office of Engineering and Technology.
[FR Doc. 2024-04975 Filed 3-7-24; 8:45 am]

BILLING CODE 6712-01-P

FEDERAL COMMUNICATIONS COMMISSION

[GN Docket No. 17-208; FR ID 206809]

Meeting of the Communications Equity and Diversity Council

AGENCY: Federal Communications Commission.

ACTION: Notice.

SUMMARY: In accordance with the Federal Advisory Committee Act, this notice announces the first meeting of the Federal Communications Commission's (Commission) re-chartered Communications Equity and Diversity Council (CEDC). The charter for the CEDC was renewed for a two-year period beginning June 22, 2023.

DATES: Wednesday, March 27, 2024, from 10:00 a.m. to 2:00 p.m.

ADDRESSES: The CEDC meeting will be held in a hybrid manner. The public may attend the meeting in person at FCC headquarters at 45 L Street NE, Washington, DC. The meeting also will be available to the public for viewing via the internet at <https://www.fcc.gov/live>.

FOR FURTHER INFORMATION CONTACT: Rodney McDonald, Designated Federal Officer (DFO) of the CEDC, (202) 418-7513, Rodney.McDonald@fcc.gov; Diana Coho, Deputy DFO of the CEDC, (717) 338-2848, Diana.Coho@fcc.gov; Jaime McCoy, Deputy DFO of the CEDC, (202) 418-2320, Jaime.McCoy@fcc.gov; or Sima Nilsson, Deputy DFO of the CEDC, (202) 418-2708, Sima.Nilsson@fcc.gov. More information about the CEDC is available at <https://www.fcc.gov/communications-equity-and-diversity-council>.

SUPPLEMENTARY INFORMATION: The CEDC meeting is accessible to the public on the internet via live feed from the FCC's web page at <https://www.fcc.gov/live>. Open captioning will be provided for this event. Other reasonable accommodations for persons with disabilities are available upon request. Requests for such accommodations should be submitted via email to fcc504@fcc.gov or by calling the Consumer and Governmental Affairs Bureau at (202) 418-0530 (voice). Such requests should include a detailed

description of the accommodation needed. In addition, please include a way for the Commission to contact the requester if more information is needed to fulfill the request. Please allow at least five days' advance notice for accommodation requests; last minute requests will be accepted but may not be possible to accommodate. Members of the public may submit any questions during the meeting to livequestions@fcc.gov. Oral statements at the meeting by parties or entities not represented on the CEDC will be permitted to the extent time permits and at the discretion of the CEDC Chair and the DFO.

Members of the public also may submit comments to the CEDC using the FCC's Electronic Comment Filing System, ECFS, at www.fcc.gov/ecfs. Comments to the CEDC should be filed in GN Docket No. 17–208.

Proposed Agenda: The agenda for the meeting will include introducing members of the CEDC, announcing working groups that will assist the CEDC in carrying out its work, and receiving guidance from the Commission's Offices of General Counsel and Managing Director regarding federal advisory committee best practices. This agenda may be modified at the discretion of the CEDC Chair and the DFO. It is anticipated that any significant agenda modifications will be posted in advance on the CEDC web page. As will be discussed at the meeting, the Council's mission is to make recommendations to the Commission on advancing equity in the provision of and access to digital communication services and products for all people of the United States, without discrimination on the basis of race, color, religion, national origin, sex, or disability. It shall provide recommendations to the Commission on how to empower people of color and others who have been historically underserved, including persons who live in rural areas, and persons otherwise adversely affected by persistent poverty or inequality, to access, leverage, and benefit from the wide range of opportunities made possible by technology, communication services, and next-generation networks. The CEDC is organized under, and operates in accordance with, the provisions of the Federal Advisory Committee Act (5 U.S.C. App. 10).

Federal Communications Commission.

Jodie May,

Division Chief, Competition Policy Division, Wireline Competition Bureau.

[FR Doc. 2024–04954 Filed 3–7–24; 8:45 am]

BILLING CODE 6712–01–P

FEDERAL COMMUNICATIONS COMMISSION

[OMB 3060–0188; FR ID 206934]

Information Collection Being Reviewed by the Federal Communications Commission Under Delegated Authority

AGENCY: Federal Communications Commission.

ACTION: Notice and request for comments.

SUMMARY: As part of its continuing effort to reduce paperwork burdens, and as required by the Paperwork Reduction Act of 1995 (PRA), the Federal Communications Commission (FCC or Commission) invites the general public and other Federal agencies to take this opportunity to comment on the following information collections. Comments are requested concerning: whether the proposed collection of information is necessary for the proper performance of the functions of the Commission, including whether the information shall have practical utility; the accuracy of the Commission's burden estimate; ways to enhance the quality, utility, and clarity of the information collected; ways to minimize the burden of the collection of information on the respondents, including the use of automated collection techniques or other forms of information technology; and ways to further reduce the information collection burden on small business concerns with fewer than 25 employees. The FCC may not conduct or sponsor a collection of information unless it displays a currently valid Office of Management and Budget (OMB) control number. No person shall be subject to any penalty for failing to comply with a collection of information subject to the PRA that does not display a valid OMB control number.

DATES: Written PRA comments should be submitted on or before May 7, 2024. If you anticipate that you will be submitting comments but find it difficult to do so within the period of time allowed by this notice, you should advise the contact listed below as soon as possible.

ADDRESSES: Direct all PRA comments to Cathy Williams, FCC, via email to PRA@fcc.gov and to Cathy.Williams@fcc.gov.

FOR FURTHER INFORMATION CONTACT: For additional information about the information collection, contact Cathy Williams at (202) 418–2918.

SUPPLEMENTARY INFORMATION:

OMB Control Number: 3060–0188.

Title: Call Sign Reservation and Authorization System, FCC Form 380.

Form Number: FCC Form 380.

Type of Review: Extension of a currently approved collection.

Respondents: Business or other for-profit, Not-for-profit institutions; and State, local, or tribal government.

Number of Respondents and Responses: 1,600 respondents; 1,600 responses.

Estimated Hours per Response: 0.166–0.25 hours.

Frequency of Response: On occasion reporting requirements.

Total Annual Burden: 333 hours.

Total Annual Cost: \$162,000.

Obligation to Respond: Required to obtain or retain benefits. The statutory authority for this collection is contained in Sections 154(i) and 303 of the Communications Act of 1934, as amended.

Needs and Uses: The information collection requirements contained in 47 CFR 73.3550 provide that all requests for new or modified call signs be made via the on-line call sign reservation and authorization. The Commission uses an on-line system, FCC Form 380, for the electronic preparation and submission of requests for the reservation and authorization of new and modified call signs. Access to the call sign reservation and authorization system is made by broadcast licensees and permittees, or by persons acting on their behalf, via the internet's World Wide Web. This on-line, electronic call sign system enables users to determine the availability and licensing status of call signs; to request an initial, or change an existing, call sign; and to determine and submit more easily the appropriate fee, if any. Because all elements necessary to make a valid call sign reservation are encompassed within the on-line system, this system prevents users from filing defective or incomplete call sign requests. The electronic system also provides greater certitude, as a selected call sign is effectively reserved as soon as the user has submitted its call sign request. This electronic call sign reservation and authorization system has significantly improved service to all radio and television broadcast station licensees and permittees.

Federal Communications Commission.

Marlene Dortch,

Secretary, Office of the Secretary.

[FR Doc. 2024–04927 Filed 3–7–24; 8:45 am]

BILLING CODE 6712–01–P

FEDERAL COMMUNICATIONS COMMISSION

[OMB 3060–1013; FR ID 207046]

Information Collection Being Reviewed by the Federal Communications Commission Under Delegated Authority**AGENCY:** Federal Communications Commission.**ACTION:** Notice and request for comments.

SUMMARY: As part of its continuing effort to reduce paperwork burdens, and as required by the Paperwork Reduction Act of 1995 (PRA), the Federal Communications Commission (FCC or Commission) invites the general public and other Federal agencies to take this opportunity to comment on the following information collections. Comments are requested concerning: whether the proposed collection of information is necessary for the proper performance of the functions of the Commission, including whether the information shall have practical utility; the accuracy of the Commission's burden estimate; ways to enhance the quality, utility, and clarity of the information collected; ways to minimize the burden of the collection of information on the respondents, including the use of automated collection techniques or other forms of information technology; and ways to further reduce the information collection burden on small business concerns with fewer than 25 employees. The FCC may not conduct or sponsor a collection of information unless it displays a currently valid Office of Management and Budget (OMB) control number. No person shall be subject to any penalty for failing to comply with a collection of information subject to the PRA that does not display a valid OMB control number.

DATES: Written PRA comments should be submitted on or before May 7, 2024. If you anticipate that you will be submitting comments but find it difficult to do so within the period of time allowed by this notice, you should advise the contact listed below as soon as possible.

ADDRESSES: Direct all PRA comments to Cathy Williams, FCC, via email to PRA@fcc.gov and to Cathy.Williams@fcc.gov.

FOR FURTHER INFORMATION CONTACT: For additional information about the information collection, contact Cathy Williams at (202) 418–2918.

SUPPLEMENTARY INFORMATION:

OMB Control Number: 3060–1013.
Title: Mitigation of Orbital Debris.

Form Number: N/A.
Type of Review: Extension of a currently approved collection.
Respondents: Business or other for-profit entities, not-for-profit institutions.
Number of Respondents: 46 respondents; 46 responses.
Estimated Time per Response: 8 hours.
Frequency of Response: On occasion reporting requirement.
Obligation to Respond: Required to obtain or retain benefits. The Commission has statutory authority for the information collection requirements under 47 U.S.C. 151, 154(i), 301, 303, 307, 308, 309, and 310.

Total Annual Burden: 368 hours.
Annual Cost Burden: \$88,550.
Needs and Uses: The Federal Communications Commission requests that the Office of Management and Budget (OMB) approve an extension of a currently approved collection titled “Mitigation of Orbital Debris” under OMB Control No. 3060–1013. In the past four years, the Commission adopted three orders related to orbital debris mitigation: (1) the Commission's Report and Order, FCC 20–54, IB Docket No. 18–313, titled “Mitigation of Orbital Debris in the New Space Age” (*Orbital Debris Report and Order*), and released on April 24, 2020; (2) the Commission's Second Report and Order, FCC 22–74, IB Docket No. 18–313, titled “Mitigation of Orbital Debris in the New Space Age” (*Orbital Debris Second Report and Order*); and (3) the Commission's Order on Reconsideration, FCC 24–6, IB Docket No. 18–313, titled “Mitigation of Orbital Debris in the New Space Age” (*Orbital Debris Reconsideration Order*).

In the *Orbital Debris Report and Order*, the Commission updated its rules related to orbital debris mitigation, including application requirements. The rules are designed to ensure that (1) the Commission's actions concerning radio communications, including licensing U.S. spacecraft and granting access to the U.S. market for non-U.S. spacecraft, mitigate the growth of orbital debris, while at the same time not creating undue regulatory obstacles to new satellite ventures; and (2) Commission decisions are consistent with the public interest in space remaining viable for future satellites and systems and the many services that those systems provide to the public. The rules adopted by the *Orbital Debris Report and Order* also provided additional detail to applicants on what information is expected under the Commission's rules, which can help to increase certainty in the application filing process. The information collection serves the public interest by ensuring that the

Commission and public have necessary information about satellite applicants' plans for mitigation of orbital debris.

Specifically, the *Orbital Debris Report and Order* contained new or modified information collection requirements listed below, applicable to applicants seeking experimental licenses for satellite operations under part 5 of the Commission's rules, as well as to licensees under part 97 submitting notifications to the Commission prior to launch of a satellite amateur station:¹

(1) Existing disclosure requirements have been revised to include specific metrics in several areas, including: probability that the space stations will become a source of debris by collision with small debris and meteoroids that would cause loss of control and prevent disposal; probability of collision between any non-geostationary orbit (NGSO) space station and other large objects; and casualty risk associated with any individual spacecraft that will be disposed by atmospheric re-entry.

(2) Where relevant, the disclosures must also include the following: use of separate deployment devices, distinct from the space station launch vehicle, that may become a source of orbital debris; potential release of liquids that will persist in droplet form; and any planned proximity operations and debris generation that will or may result from the proposed operations, including any planned release of debris, the risk of accidental explosions, the risk of accidental collision, and measures taken to mitigate those risks.

(3) The existing disclosure requirement to analyze potential collision risk associated with space station(s) orbits has been modified to specify that the disclosure identify characteristics of the space station(s) orbits that may present a collision risk, including any planned and/or operational space stations in those orbits, and indicate what steps, if any, have been taken to coordinate with the other spacecraft or system, or what other measures the operator plans to use to avoid collision.

(4) For NGSO space stations that will transit through the orbits used by any inhabitable spacecraft, including the International Space Station, the disclosure must include the design and operational strategies, if any, that will be used to minimize the risk of collision and avoid posing any operational constraints to the inhabitable spacecraft.

¹ The *Orbital Debris Report and Order* also added new and modified information collection requirements for satellite applicants under part 25 of the Commission's rules, which the Commission is in the process of seeking OMB approval separately.

(5) The disclosure must include a certification that upon receipt of a space situational awareness conjunction warning, the operator will review and take all possible steps to assess the collision risk, and will mitigate the collision risk if necessary. As appropriate, steps to assess and mitigate the collision risk should include, but are not limited to: contacting the operator of any active spacecraft involved in such a warning; sharing ephemeris data and other appropriate operational information with any such operator; and modifying space station attitude and/or operations.

(6) For NGSO space stations the disclosure must describe the extent of satellite maneuverability.

(7) The disclosure must address trackability of the space station(s). For NGSO space stations, the disclosure must also include: (a) how the operator plans to identify the space station(s) following deployment and whether the space station tracking will be active or passive; (b) whether, prior to deployment the space station(s) will be registered with the 18th Space Control Squadron or successor entity; and (c) the extent to which the space station operator plans to share information regarding initial deployment, ephemeris, and/or planned maneuvers with the 18th Space Control Squadron or successor entity, other entities that engage in space situational awareness or space traffic management functions, and/or other operators.

(8) For NGSO space stations, additional disclosures must be provided regarding spacecraft disposal, including, for some space stations, a demonstration that the probability of success of the chosen disposal method is 0.9 or greater for any individual space station, and for multi-satellite systems, a demonstration including additional information regarding efforts to achieve a higher probability of success.

The information collection requirements are contained in 47 CFR 5.64 and 47 CFR 97.207.

In the 2022 *Orbital Debris Second Report and Order*, the Commission required all space stations ending their mission in, or passing through, the low earth orbit (LEO) region, and planning disposal though uncontrolled atmospheric re-entry following the completion of the mission, to complete disposal as soon as practicable, and no later than five years after the end of the mission. The *Orbital Debris Second Report and Order* did not modify information collected under 47 CFR 5.64 and 47 CFR 97.207.

In the 2024 *Orbital Debris Reconsideration Order*, the Commission

upheld the current regulatory environment for orbital debris mitigation, and provided additional clarity and guidance for satellite operators while reinforcing the Commission's commitment to space safety. The *Orbital Debris Reconsideration Order* did not modify information collected under 47 CFR 5.64 and 47 CFR 97.207.

Federal Communications Commission.

Marlene Dortch,

Secretary, Office of the Secretary.

[FR Doc. 2024-05000 Filed 3-7-24; 8:45 am]

BILLING CODE 6712-01-P

FEDERAL COMMUNICATIONS COMMISSION

[OMB 3060-1162; FR ID 206807]

Information Collection Being Reviewed by the Federal Communications Commission

AGENCY: Federal Communications Commission.

ACTION: Notice and request for comments.

SUMMARY: As part of its continuing effort to reduce paperwork burdens, and as required by the Paperwork Reduction Act of 1995 (PRA), the Federal Communications Commission (FCC or Commission) invites the general public and other Federal agencies to take this opportunity to comment on the following information collections. Comments are requested concerning: whether the proposed collection of information is necessary for the proper performance of the functions of the Commission, including whether the information shall have practical utility; the accuracy of the Commission's burden estimate; ways to enhance the quality, utility, and clarity of the information collected; ways to minimize the burden of the collection of information on the respondents, including the use of automated collection techniques or other forms of information technology; and ways to further reduce the information collection burden on small business concerns with fewer than 25 employees. The FCC may not conduct or sponsor a collection of information unless it displays a currently valid Office of Management and Budget (OMB) control number. No person shall be subject to any penalty for failing to comply with a collection of information subject to the PRA that does not display a valid OMB control number.

DATES: Written PRA comments should be submitted on or before May 7, 2024.

If you anticipate that you will be submitting comments but find it difficult to do so within the period of time allowed by this notice, you should advise the contact listed below as soon as possible.

ADDRESSES: Direct all PRA comments to Cathy Williams, FCC, via email to PRA@fcc.gov and to Cathy.Williams@fcc.gov.

FOR FURTHER INFORMATION CONTACT: For additional information about the information collection, contact Cathy Williams at (202) 418-2918.

SUPPLEMENTARY INFORMATION:

OMB Control Number: 3060-1162.

Title: Closed Captioning of Video Programming Delivered Using internet Protocol, and Apparatus Closed Caption Requirements.

Form Number: N/A.

Type of Review: Extension of a currently approved collection.

Respondents: Individuals or Household, Businesses or other for-profit, Not-for-profit institutions, State, local, or tribal government, Federal Government.

Number of Respondents and Responses: 1,172 respondents; 3,341 responses.

Estimated Time per Response: 0.084-10 hours.

Frequency of Response: One time and on occasion reporting requirements; Recordkeeping requirement; Third party disclosure requirement.

Obligation to Respond: Mandatory; Required to obtain or retain benefits. The statutory authority for this collection is contained in the Twenty-First Century Communications and Video Accessibility Act of 2010, Public Law 111-260, 124 Stat. 2751, and sections 4(i), 4(j), 303, 330(b), 713, and 716 of the Communications Act of 1934, as amended (the Act), 47 U.S.C. 154(i), 154(j), 303, 330(b), 613, and 617.

Total Annual Burden: 9,197 hours.

Total Annual Cost: \$95,700.

Needs and Uses: The Twenty-First Century Communications and Video Accessibility Act of 2010 (CVAA) directed the Commission to revise its regulations to mandate closed captioning on video programming delivered via internet Protocol (IP) that was published or exhibited on television with captions after the effective date of the regulations. Accordingly, the Commission requires video programming owners (VPOs) to send program files to video programming distributors and providers (hereinafter VPDs) with required captions, and it requires VPDs to enable the rendering or pass through of all required captions to the end user. The CVAA also directed the Commission to

revise its regulations to mandate that all apparatus designed to receive, play back, or record video programming be equipped with built-in closed caption decoder circuitry or capability designed to display closed-captioned video programming, except that apparatus that use a picture screen that is 13 inches or smaller and recording devices must comply only if doing so is achievable. These rules are codified at 47 CFR 79.4 and 79.100–79.104.

The information collection requirements consist of:

(a) Mechanism for information about video programming subject to the IP closed captioning requirements.

Pursuant to 47 CFR 79.4(c)(1)(ii) and (c)(2)(ii) of the Commission's rules, VPOs and VPDs must agree upon a mechanism to make information available to VPDs about video programming that becomes subject to the requirements of 47 CFR 79.4 on an ongoing basis. VPDs must make a good faith effort to identify video programming that must be captioned when delivered using IP using the agreed upon mechanism.

For example, VPOs and VPDs may agree on a mechanism whereby the VPOs provide captions or certifications that captions are not required, and update those certifications and provide captions when captions later become required. A VPD may rely in good faith on a certification by a VPO that the programming need not be captioned if: (1) the certification includes a clear and concise explanation of why captions are not required; and (2) the VPD is able to produce the certification to the Commission in the event of a complaint. VPOs may provide certifications for specific programming or a more general certification, for example, for all programming covered by a particular contract.

VPDs may seek Commission determinations that other proposed mechanisms provide adequate information for them to rely on in good faith by filing an informal request and providing sufficient information for the Commission to make such determinations.

(b) Contact information for the receipt and handling of written closed captioning complaints.

Pursuant to 47 CFR 79.4(c)(2)(iii), VPDs must make their contact information available to end users for the receipt and handling of written IP closed captioning complaints. The required contact information includes the name of a person with primary responsibility for IP captioning issues and who can ensure compliance with these rules, as well as the person's title

or office, telephone number, fax number, postal mailing address, and email address. VPDs must keep this information current and update it within 10 business days of any change. The Commission expects that such contact information will be prominently displayed in a way that it is accessible to all end users. A general notice on the VPD's website with such contact information, if provided, must be provided in a location that is conspicuous to viewers.

(c) Petitions for exemption based on economic burden.

Pursuant to 47 CFR 79.4(d), a VPO or VPD may petition the Commission for a full or partial exemption from the closed captioning requirements for IP-delivered video programming based upon a showing that they would be economically burdensome. Petitions for exemption must be supported with sufficient evidence to demonstrate economic burden (significant difficulty or expense). The Commission will consider four specific factors when determining economic burden and any other factors the petitioner deems relevant, along with any available alternatives that might constitute a reasonable substitute for the closed captioning requirements. The Commission will evaluate economic burden with regard to the individual outlet. Petitions and subsequent pleadings must be filed electronically.

The Commission will place such petitions on public notice. Comments or oppositions to the petition may be filed electronically within 30 days after release of the public notice of the petition, and must include a certification that the petitioner was served with a copy. The petitioner may reply to any comments or oppositions filed within 20 days after the close of the period for filing comments or oppositions, and replies must include a certification that the commenting or opposing party was served with a copy. Upon a finding of good cause, the Commission may lengthen or shorten any comment period and waive or establish other procedural requirements. Petitions and responsive pleadings must include a detailed, full showing, supported by affidavit, of any facts or considerations relied on.

(d) Complaints alleging violations of the closed captioning rules for IP-delivered video programming.

Pursuant to 47 CFR 79.4(e), a written complaint alleging a violation of the closed captioning rules for IP-delivered video programming may be filed with the Commission or with the VPD responsible for enabling the rendering or pass through of the closed captions

for the video programming. Complaints must be filed within 60 days after the date the complainant experienced a problem with captioning. Complaints should (but are not required to) include certain information.

If the complaint is filed first with the VPD, the VPD must respond in writing to the complainant within 30 days after receipt of a closed captioning complaint. If a VPD fails to respond timely, or the response does not satisfy the consumer, the complainant may re-file the complaint with the Commission within 30 days after the time allotted for the VPD to respond. If a consumer re-files the complaint with the Commission (after filing with the VPD) and the complaint satisfies the requirements, the Commission will forward the complaint to the named VPD, as well as to any other VPD and/or VPO that Commission staff determines may be involved, who then must respond in writing to the Commission and the complainant within 30 days after receipt of the complaint from the Commission.

If the complaint is filed first with the Commission and the complaint satisfies the requirements, the Commission will forward the complaint to the named VPD and/or VPO, and to any other VPD and/or VPO that Commission staff determine may be involved, who must respond in writing to the Commission and the complainant within 30 days after receipt of the complaint from the Commission. In response to a complaint, a VPD and/or VPO must provide the Commission with sufficient records and documentation. The Commission will review all relevant information provided by the complainant and the subject VPDs and/or VPOs, as well as any additional information the Commission deems relevant from its files or public sources. The Commission may request additional information from any relevant entities when, in the estimation of Commission staff, such information is needed to investigate the complaint or adjudicate potential violation(s) of Commission rules. When the Commission requests additional information, parties to which such requests are addressed must provide the requested information in the manner and within the time period the Commission specifies.

(e) Requests for Commission determination of technical feasibility of apparatus closed caption requirements.

Pursuant to 47 CFR 79.103(a), as of January 1, 2014, all digital apparatus designed to receive or play back video programming that uses a picture screen of any size must be equipped with built-in closed caption decoder circuitry or

capability designed to display closed-captioned video programming, if technically feasible. If new apparatus or classes of apparatus for viewing video programming emerge on which it would not be technically feasible to include closed captioning, parties may raise that argument as a defense to a complaint or, alternatively, file a request under 47 CFR 1.41 for a Commission determination of technical feasibility before manufacturing or importing the product.

(f) Requests for Commission determination of achievability of apparatus closed caption requirements.

Pursuant to 47 CFR 79.103(a), as of January 1, 2014, all digital apparatus designed to receive or play back video programming that use a picture screen less than 13 inches in size must be equipped with built-in closed caption decoder circuitry or capability designed to display closed-captioned video programming, only if doing so is achievable. In addition, pursuant to 47 CFR 79.104(a), as of January 1, 2014, all apparatus designed to record video programming must enable the rendering or the pass through of closed captions such that viewers are able to activate and de-activate the closed captions as the video programming is played back, only if doing so is achievable.

Manufacturers of such apparatus may petition the Commission, pursuant to 47 CFR 1.41, for a full or partial exemption from the closed captioning requirements before manufacturing or importing the apparatus or may assert as a response to a complaint that these requirements, in full or in part, are not achievable. Pursuant to 47 CFR 79.103(b)(3), such a petition or response must be supported with sufficient evidence to demonstrate that compliance is not achievable (meaning with reasonable effort or expense) and the Commission will consider four specific factors when making such determinations.

(g) Petitions for purpose-based waivers of apparatus closed caption requirements.

Manufacturers seeking certainty prior to the sale of a device may petition the Commission, pursuant to 47 CFR 79.103(b)(4), for a full or partial waiver of the closed captioning requirements based on one of the following provisions:

(i) The apparatus is primarily designed for activities other than receiving or playing back video programming transmitted simultaneously with sound; or

(ii) The apparatus is designed for multiple purposes, capable of receiving or playing back video programming transmitted simultaneously with sound

but whose essential utility is derived from other purposes.

(h) Complaints alleging violations of the apparatus closed caption requirements.

Consumers may file written complaints alleging violations of the Commission's rules, 47 CFR 79.101–79.104, requiring apparatus designed to receive, play back, or record video programming to be equipped with built-in closed caption decoder circuitry or capability designed to display closed captions. A written complaint filed with the Commission must be transmitted to the Consumer and Governmental Affairs Bureau through the Commission's online informal complaint filing system, U.S. Mail, overnight delivery, or facsimile. Such complaints should include certain information about the complainant and the alleged violation. The Commission may forward such complaints to the named manufacturer or provider, as well as to any other entity that Commission staff determines may be involved, and may request additional information from any relevant parties when, in the estimation of Commission staff, such information is needed to investigate the complaint or adjudicate potential violations of Commission rules.

Federal Communications Commission.

Marlene Dortch,

Secretary, Office of the Secretary.

[FR Doc. 2024–04920 Filed 3–7–24; 8:45 am]

BILLING CODE 6712–01–P

FEDERAL RESERVE SYSTEM

Change in Bank Control Notices; Acquisitions of Shares of a Bank or Bank Holding Company

The notificants listed below have applied under the Change in Bank Control Act (Act) (12 U.S.C. 1817(j)) and § 225.41 of the Board's Regulation Y (12 CFR 225.41) to acquire shares of a bank or bank holding company. The factors that are considered in acting on the applications are set forth in paragraph 7 of the Act (12 U.S.C. 1817(j)(7)).

The public portions of the applications listed below, as well as other related filings required by the Board, if any, are available for immediate inspection at the Federal Reserve Bank(s) indicated below and at the offices of the Board of Governors. This information may also be obtained on an expedited basis, upon request, by contacting the appropriate Federal Reserve Bank and from the Board's Freedom of Information Office at <https://www.federalreserve.gov/foia/>

request.htm. Interested persons may express their views in writing on the standards enumerated in paragraph 7 of the Act.

Comments regarding each of these applications must be received at the Reserve Bank indicated or the offices of the Board of Governors, Ann E. Misback, Secretary of the Board, 20th Street and Constitution Avenue NW, Washington, DC 20551–0001, not later than March 25, 2024.

A. Federal Reserve Bank of Minneapolis (Stephanie Weber, Assistant Vice President) 90 Hennepin Avenue, Minneapolis, Minnesota 55480–0291. Comments can also be sent electronically to MA@mpls.frb.org:

1. *The Estate of Norman C. Skalicky, Maple Grove, Minnesota; the Norman C. Skalicky Revocable Trust u/a/d July 10, 2002, Las Vegas, Nevada; Kelly A. Skalicky, Las Vegas, Nevada, as personal representative of the Estate of Norman C. Skalicky and trustee of the Norman C. Skalicky Revocable Trust u/a/d July 10, 2002; to join a group acting in concert, to retain voting shares of Stearns Financial Services, Inc., St. Cloud, Minnesota, and thereby indirectly retain voting shares of Stearns Bank National Association, St. Cloud, Minnesota; Stearns Bank of Upsala, National Association, Upsala, Minnesota; and Stearns Bank of Holdingford, National Association, Holdingford, Minnesota.*

B. Federal Reserve Bank of St. Louis (Holly A. Rieser, Senior Manager) P.O. Box 442, St. Louis, Missouri 63166–2034. Comments can also be sent electronically to Comments.Applications@stls.frb.org:

1. *Rondal L. Wright Irrevocable Grantor Trust, R. Brent Wright as trustee and individually, both of Glasgow, Kentucky; to acquire voting shares of Buffalo Bancshares, Inc., and thereby indirectly acquire voting shares of Bank of Buffalo, both of Buffalo, Kentucky.*

Board of Governors of the Federal Reserve System.

Michele Taylor Fennell,

Deputy Associate Secretary of the Board.

[FR Doc. 2024–04974 Filed 3–7–24; 8:45 am]

BILLING CODE P

DEPARTMENT OF HEALTH AND HUMAN SERVICES**Centers for Disease Control and Prevention****Disease, Disability, and Injury Prevention and Control Special Emphasis Panel (SEP)—GH21-001, Conducting Public Health Research in Thailand: Technical Collaboration With the Ministry of Public Health (MOPH) in the Kingdom of Thailand; GH21-003, Advancing Public Health Research in Kenya; and GH23-003, Conducting Public Health Research With Universities in Thailand; Cancellation of Meeting**

AGENCY: Centers for Disease Control and Prevention, Department of Health and Human Services.

ACTION: Notice.

FOR FURTHER INFORMATION CONTACT:

Hylan Shoob, Ph.D., Scientific Review Officer, Global Health Center, Centers for Disease Control and Prevention, 1600 Clifton Road NE, Mailstop H21-9, Atlanta, Georgia 30329-4027. Telephone: (404) 639-4796; Email: HShoob@cdc.gov.

SUPPLEMENTARY INFORMATION: Notice is hereby given of a change in the meeting of the Disease, Disability, and Injury Prevention and Control Special Emphasis Panel (SEP)—GH21-001, Conducting Public Health Research in Thailand: Technical collaboration with the Ministry of Public Health (MOPH) in the Kingdom of Thailand; GH21-003, Advancing Public Health Research in Kenya; and GH23-003, Conducting Public Health Research with Universities in Thailand; April 11, 2024, 9 a.m.–2 p.m., EDT, teleconference, in the original **Federal Register** notice. The meeting notice was published in the **Federal Register** on February 13, 2024, 89 FR 10081.

This meeting is being canceled in its entirety.

The Director, Office of Strategic Business Initiatives, Office of the Chief Operating Officer, Centers for Disease Control and Prevention, has been delegated the authority to sign **Federal Register** notices pertaining to announcements of meetings and other committee management activities, for both the Centers for Disease Control and

Prevention and the Agency for Toxic Substances and Disease Registry.

Kalwant Smagh,

Director, Office of Strategic Business Initiatives, Office of the Chief Operating Officer, Centers for Disease Control and Prevention.

[FR Doc. 2024-04963 Filed 3-7-24; 8:45 am]

BILLING CODE 4163-18-P

DEPARTMENT OF HEALTH AND HUMAN SERVICES**Centers for Disease Control and Prevention****Clinical Laboratory Improvement Advisory Committee; Notice of Charter Renewal**

AGENCY: Centers for Disease Control and Prevention (CDC), Department of Health and Human Services (HHS).

ACTION: Notice of charter renewal.

SUMMARY: The Centers for Disease Control and Prevention (CDC), within the Department of Health and Human Services (HHS), announces the renewal of the charter of the Clinical Laboratory Improvement Advisory Committee (CLIAC).

FOR FURTHER INFORMATION CONTACT:

Reynolds M. Salerno, Ph.D., Designated Federal Officer, Clinical Laboratory Improvement Advisory Committee, Centers for Disease Control and Prevention, Department of Health and Human Services, 1600 Clifton Road NE, Mailstop V24-3, Atlanta, Georgia 30329-4027. Telephone: (404) 498-6516; Email: RSalerno@cdc.gov.

SUPPLEMENTARY INFORMATION: CDC is providing notice under 5 U.S.C. 1001-1014 of the renewal of the charter of the Clinical Laboratory Improvement Advisory Committee, Centers for Disease Control and Prevention, Department of Health and Human Services. This charter has been renewed for a two-year period through February 19, 2026.

The Director, Office of Strategic Business Initiatives, Office of the Chief Operating Officer, Centers for Disease Control and Prevention, has been delegated the authority to sign **Federal Register** notices pertaining to announcements of meetings and other committee management activities, for both the Centers for Disease Control and

Prevention and the Agency for Toxic Substances and Disease Registry.

Kalwant Smagh,

Director, Office of Strategic Business Initiatives, Office of the Chief Operating Officer, Centers for Disease Control and Prevention.

[FR Doc. 2024-04962 Filed 3-7-24; 8:45 am]

BILLING CODE 4163-18-P

DEPARTMENT OF HEALTH AND HUMAN SERVICES**Administration for Children and Families****Proposed Information Collection Activity; Request for Assistance for Child Victims of Human Trafficking**

AGENCY: Office on Trafficking in Persons, Administration for Children and Families, Department of Health and Human Services.

ACTION: Request for public comments.

SUMMARY: The Administration for Children and Families (ACF), Office on Trafficking in Persons (OTIP) is requesting a three-year extension of the form: Request for Assistance (RFA) for Child Victims of Human Trafficking (Office of Management and Budget (OMB) #0970-0362, expiration 09/30/2024). Burden estimates have been updated based on observed increases in the volume of requests received. The RFA form and estimated time per response remains the same.

DATES: *Comments due within 60 days of publication.* In compliance with the requirements of the Paperwork Reduction Act of 1995, ACF is soliciting public comment on the specific aspects of the information collection described above.

ADDRESSES: You can obtain copies of the proposed collection of information and submit comments by emailing infocollection@acf.hhs.gov. Identify all requests by the title of the information collection.

SUPPLEMENTARY INFORMATION:

Description: The Trafficking Victims Protection Act (TVPA) of 2000, as amended, directs the Secretary of the U.S. Department of Health and Human Services (HHS), upon receipt of credible information that a foreign national minor may have been subjected to a severe form of trafficking in persons and is seeking assistance available to victims of trafficking, to promptly determine if the child is eligible for benefits and services to the same extent as refugees. HHS delegated this authority to OTIP.

OTIP developed a RFA form for case managers, attorneys, law enforcement

officers, child welfare workers, and other representatives to report these trafficking concerns to HHS in accordance with the TVPA of 2000, as amended, and allow for OTIP to review the concerns and determine eligibility for benefits.

Specifically, the RFA form asks the requester for their identifying information, identifying information for the child, and information describing the potential trafficking concerns. The RFA form takes into consideration the need to compile information regarding a child’s experiences in a trauma-informed and child-centered manner and assists the requester in assessing whether the child may have been subjected to a severe form of trafficking in persons.

The information provided through the completion of a RFA form enables OTIP to make prompt determinations regarding a foreign national minor’s eligibility for assistance, facilitate the required consultation process should the minor receive interim assistance, and enable OTIP to assess and address potential child protection issues. OTIP also uses the information provided to respond to congressional inquiries, fulfill federal reporting requirements, and inform policy and program

development that is responsive to the needs of victims.

In 2019, OTIP launched Shepherd, an online case management system, to process requests for assistance and certification on behalf of foreign national minor and adult victims of trafficking. If a requester encounters issues submitting a request through Shepherd, they may submit the RFA form to OTIP as a password protected PDF to childtrafficking@acf.hhs.gov.

Respondents: Representatives of governmental entities, members of the community, and nongovernmental entities providing social, legal, or protective services to foreign national minors in the United States who may have been subjected to severe forms of trafficking in persons. Furthermore, representatives within the community with a concern that a foreign national minor may have been subjected to severe forms of trafficking in persons may also use the RFA form.

Annual Burden Estimates

Increased awareness of reporting requirements under the TVPA of 2000, as amended among providers who serve foreign national children and youth has resulted in sustained, year-over-year increases in the number of RFA forms

received by OTIP since fiscal year 2021. While the number of RFA forms received by OTIP each year largely reflects OTIP’s efforts to engage case managers, attorneys, law enforcement officers, child welfare workers, and other representatives who serve foreign national children and youth, the number of RFA forms received is also impacted by a variety of social, political, and environmental factors that impact migration trends, including natural disasters and other climate-mediated events, that fluctuate each year. In fiscal year 2021, a record number of unique individuals (2,178) were referred to OTIP through 2,650 total RFA forms. In fiscal year 2022, 3,150 unique individuals were referred to OTIP through 3,709 total RFA forms. In fiscal year 2023, 3,612 unique individuals were referred to OTIP through 4,052 total RFA forms. There are no changes proposed to the RFA form but based on the increased need for trafficking-specific case management services among foreign national children and youth, as evidenced through sustained increases in the volume of RFA forms received by OTIP each year since fiscal year 2021, burden estimates for this collection have been revised.

Instrument	Total number of respondents	Total number of responses per respondent	Average burden hours per response	Total burden hours	Annual burden hours
Request for Assistance for Child Victims of Human Trafficking	10,500	1	1	10,500	3,500

Comments: The Department specifically requests comments on (a) whether the proposed collection of information is necessary for the proper performance of the functions of the agency, including whether the information shall have practical utility; (b) the accuracy of the agency’s estimate of the burden of the proposed collection of information; (c) the quality, utility, and clarity of the information to be collected; and (d) ways to minimize the burden of the collection of information on respondents, including through the use of automated collection techniques or other forms of information technology. Consideration will be given to comments and suggestions submitted within 60 days of this publication.

Authority: 22 U.S.C. 7105(b).

Mary C. Jones,

ACF/OPRE Certifying Officer.

[FR Doc. 2024-04931 Filed 3-7-24; 8:45 am]

BILLING CODE 4184-47-P

DEPARTMENT OF HEALTH AND HUMAN SERVICES

Administration for Children and Families

Notice for Public Comment on Administration for Native Americans’ Survey To Measure Native American Language Vitality

AGENCY: Administration for Native Americans, Administration for Children and Families, U.S. Department of Health and Human Services.

ACTION: Request for public comments.

SUMMARY: As part of the Durbin Feeling Native American Languages Act of 2022 (Durbin Feeling Act), the Administration for Native Americans (ANA) is tasked with developing a nationwide survey on Native languages, with the intent that the survey will be sent out and collected every 5 years. The survey will gather information from Tribal Governments and/or Native

language community organization representatives to report about the language use, language learning, and unmet needs in the community. The law requires that the survey makers consult with Native American Tribes, traditional leaders, and representatives of Native American language communities, including Native Hawaiian and Pacific Island communities. The data collection will provide Tribal Nations, Native American language communities, and Congress with critical information about how Federal support can best help to revitalize and maintain Native languages. For more information on the Durbin Feeling Act, please visit: <https://www.acf.hhs.gov/ana/durbin-feeling>.

DATES: Comments are due by April 8, 2024 to ensure consideration during the survey revision process.

ADDRESSES: Comments may be submitted to Amy Zukowski, Director of Program Evaluation and Planning, Administration for Native Americans,

330 C Street SW, Washington, DC 20201 or via email to ANACommissioner@acf.hhs.gov. Please use "Native Language Survey Comments" in the subject line.

FOR FURTHER INFORMATION CONTACT:

Amy Zukowski, Director, Program Evaluation and Planning, Administration for Native Americans, 330 C Street, SW, Washington, DC 20201; Telephone: (877) 922-9262; Email: ANACommissioner@acf.hhs.gov.

SUPPLEMENTARY INFORMATION:

A. Background

On January 5, 2023, the Durbin Feeling Native American Languages Act became law (Pub. L. 117-337). The purpose of this legislation is to improve interagency efforts to support Native American language reclamation efforts; reduce duplication, inefficiencies, and barriers Native American language communities face in accessing Federal programs to support efforts to revitalize, maintain, or increase the use of Native American languages; and outline the status of the vitality of Native American languages.

The law requires implementation of these actions in consultation with Indian Tribes, traditional leaders, and representatives of Native American language communities, including Native Hawaiian and Pacific Island communities.

This legislation charges ANA to lead the development and implementation of a nationwide survey on Native American languages every 5 years. ANA is working with other Federal agencies and conducting consultations with Tribes, including their speakers and language experts, in the development of this survey.

Congress outlined six topic areas that must be included in the survey:

1. Information on which Native languages are currently spoken
2. Estimates on the number of speakers of each Native language
3. Any relevant language usage statistics or information
4. Information on types of Native language projects and practices
5. Information on any unmet resources for Native languages
6. Any other necessary information

The Paperwork Reduction Act (PRA), 44 U.S.C. 3501 *et seq.*, provides that a Federal agency generally cannot conduct or sponsor a collection of information, and the public is generally not required to respond to an information collection, unless it is approved by the Office of Management and Budget (OMB) under the PRA and displays a currently valid OMB Control

Number. In addition, notwithstanding any other provisions of law, no person shall generally be subject to penalty for failing to comply with a collection of information that does not display a valid Control Number. See 5 CFR 1320.5(a) and 1320.6.

When ANA administers the survey in the future, ANA intends to make results available to the public. Collected data can serve as a guide for future policies to better support Native language reclamation efforts. The proposed survey will be completed by representatives within Tribes and communities to report on information at the community level. Participation in the survey will be voluntary, and Tribes and Native language communities will not be required to share culturally sensitive information.

B. Summary of Reviews and Consultations to Date

To date, ANA has engaged in multiple listening sessions with representatives from Hawaii and the Pacific territories, Alaska, National Indian Education Association's members, National Congress of American Indians Language Task Force, American Indian Higher Education Consortium, and the Administration for Children and Families Tribal Advisory Council. ANA also sought input through formal Tribal Consultation. ANA also convened a Community Working Group to provide advice on the survey development.

Key themes are included below.

Data should be useful to and actionable for the communities from which they were gathered:

- Findings should be made publicly available.
- Many respondents expressed hope that the data can contribute to policy change around language funding, especially around unmet needs, which were a significant concern across all listening sessions.
 - Language vitality and program sustainability can fluctuate with access or limitations to Federal funding; as such, data should be gathered that assess community-level needs to support better alignment between community priorities and Federal funding.

Language usage, preservation, and maintenance efforts are highly specific to each community:

- Many communities speak or have spoken multiple languages and/or dialects.
- Some communities have different definitions or perceptions of survey topics and may have gathered information that does not align with the survey questions.

Assessing intergenerational transmission of language and areas where language is used or spoken is critical:

- The absolute number of speakers matters, but endangered languages can go dormant within a single lifespan. Intergenerational language transmission holds cultural significance and is necessary for ongoing vitality.

- Language is a repository for cultural heritage; understanding where language is used matters.

Survey administration plans should consider accuracy of coverage and potential burden:

- Plans should be cognizant and respectful of existing administrative burdens for respondents.

- Data gathered may include estimates, and there may be overlap across organizations that may support multiple communities.

- Some communities may want to respond but be unable to do so for a variety of factors (for example, time allotted for response, capacity to gather data).

C. Guiding Questions for Comment

ANA requests comments on the draft survey found at <https://www.acf.hhs.gov/ana/durbin-feeling> and suggests the following guiding questions for consideration. For the list of draft questions and more information on the Durbin Feeling Native American Languages Act, please visit this site: <https://www.acf.hhs.gov/ana/durbin-feeling>.

1. Do the proposed survey questions address the six survey topics in a culturally relevant way? What other questions would better address the six topic areas?

2. Should we exclude any of the proposed questions from a survey that will be shared publicly? If so, please explain which and why.

3. Do the proposed terms and definitions align with your community's use of these terms and definitions?

4. What is an appropriate length of time to request for completing the survey? Consider how long it might take to (1) review instructions, (2) gather the data needed, and (3) answer the proposed questions.

5. How would you want to respond to a survey for your community? For example, would you want a web-based survey, a telephone interview, an in-person interview, a hard-copy paper survey, or a mix of these methods?

ANA and its partners will continue to deliberate, assess evidence, and take into consideration comments received

from the public before making final recommendations for the survey.

Patrice H. Kunesh,

Commissioner, Administration for Native Americans.

[FR Doc. 2024-04935 Filed 3-7-24; 8:45 am]

BILLING CODE 4184-34-P

DEPARTMENT OF HEALTH AND HUMAN SERVICES

National Institutes of Health

Center for Scientific Review; Notice of Closed Meetings

Pursuant to section 1009 of the Federal Advisory Committee Act, as amended, notice is hereby given of the following meetings.

The meetings will be closed to the public in accordance with the provisions set forth in sections 552b(c)(4) and 552b(c)(6), Title 5 U.S.C., as amended. The grant applications and the discussions could disclose confidential trade secrets or commercial property such as patentable material, and personal information concerning individuals associated with the grant applications, the disclosure of which would constitute a clearly unwarranted invasion of personal privacy.

Name of Committee: Center for Scientific Review Special Emphasis Panel; Fellowship: Infectious Disease and Immunology A.

Date: April 3-4, 2024.

Time: 10:00 a.m. to 7:00 p.m.

Agenda: To review and evaluate grant applications.

Place: National Institutes of Health, Rockledge II, 6701 Rockledge Drive, Bethesda, MD 20892.

Contact Person: Deanna C. Bublitz, Ph.D., Scientific Review Officer, Center for Scientific Review, National Institutes of Health, 6701 Rockledge Drive, Bethesda, MD 20892, (301) 594-4005, deanna.bublitz@nih.gov.

Name of Committee: Center for Scientific Review Special Emphasis Panel; Fellowships: HIV/AIDS Biological Review Panel.

Date: April 3, 2024.

Time: 10:00 a.m. to 7:00 p.m.

Agenda: To review and evaluate grant applications.

Place: National Institutes of Health, Rockledge II, 6701 Rockledge Drive, Bethesda, MD 20892.

Contact Person: Diana Maria Ortiz-Garcia, Ph.D., Scientific Review Officer, The Center for Scientific Review, The National Institutes of Health, 6701 Rockledge Drive, Bethesda, MD 20892, 301-594-5614, diana.ortiz-garcia@nih.gov.

Name of Committee: Center for Scientific Review Special Emphasis Panel; Member Conflict: HIV Vaccine Development and Immunopathogenesis.

Date: April 3, 2024.

Time: 10:00 a.m. to 8:00 p.m.

Agenda: To review and evaluate grant applications.

Place: National Institutes of Health, Rockledge II, 6701 Rockledge Drive, Bethesda, MD 20892.

Contact Person: Dayadevi Jirage, Ph.D., Scientific Review Officer, Center for Scientific Review, National Institutes of Health, 6701 Rockledge Drive, Room 4422, Bethesda, MD 20892, (301) 867-5309, jjiragedb@csr.nih.gov.

Name of Committee: Center for Scientific Review Special Emphasis Panel; Fellowships: Cancer Immunology and Immunotherapy II.

Date: April 3, 2024.

Time: 10:00 a.m. to 7:00 p.m.

Agenda: To review and evaluate grant applications.

Place: National Institutes of Health, Rockledge II, 6701 Rockledge Drive, Bethesda, MD 20892.

Contact Person: Ola Mae Zack Howard, Ph.D., Scientific Review Officer, Center for Scientific Review, National Institutes of Health, 6701 Rockledge Drive, Room 4192, MSC 7806, Bethesda, MD 20892, 301-451-4467, howardz@mail.nih.gov.

Name of Committee: Center for Scientific Review Special Emphasis Panel; Member Conflict: Cancer Prevention and Therapy.

Date: April 3, 2024.

Time: 12:00 p.m. to 5:00 p.m.

Agenda: To review and evaluate grant applications.

Place: National Institutes of Health, Rockledge II, 6701 Rockledge Drive, Bethesda, MD 20892.

Contact Person: Laura Asnaghi, Ph.D., Scientific Review Officer, Center for Scientific Review, National Institutes of Health, 6701 Rockville Drive, Room 6200, MSC 7804, Bethesda, MD 20892, (301) 443-1196 laura.asnaghi@nih.gov.

(Catalogue of Federal Domestic Assistance Program Nos. 93.306, Comparative Medicine; 93.333, Clinical Research, 93.306, 93.333, 93.337, 93.393-93.396, 93.837-93.844, 93.846-93.878, 93.892, 93.893, National Institutes of Health, HHS)

Dated: March 4, 2024.

Melanie J. Pantoja,

Program Analyst, Office of Federal Advisory Committee Policy.

[FR Doc. 2024-04932 Filed 3-7-24; 8:45 am]

BILLING CODE 4140-01-P

DEPARTMENT OF HEALTH AND HUMAN SERVICES

National Institutes of Health

Submission for OMB Review; 30-Day Comment Request; Cancer Therapy Evaluation Program (CTEP) Branch and Support Contracts Forms and Surveys (NCI)

AGENCY: National Institutes of Health, HHS.

ACTION: Notice.

SUMMARY: In compliance with the requirement of the Paperwork Reduction Act of 1995, the National Cancer Institute (NCI) has submitted to the Office of Management and Budget (OMB) a request for review and approval of the information collection listed below.

DATES: Comments regarding this information collection are best assured of having their full effect if received within 60 days of the date of this publication.

ADDRESSES: Written comments and recommendations for the proposed information collection should be sent within 30 days of publication of this notice to www.reginfo.gov/public/do/PRAMain. Find this particular information collection by selecting "Currently under 30-day Review—Open for Public Comments" or using the search function.

FOR FURTHER INFORMATION CONTACT: To obtain a copy of the data collection plans and instruments, submit comments in writing, or request more information on the proposed project, contact: Michael Montello, Cancer Therapy Evaluation Program—DCTD, National Cancer Institute, 9609 Medical Center Drive, Rockville, Maryland, 20850 or call non-toll-free number (240) 276-6080 or email your request, including your address to: montellom@mail.nih.gov. Formal requests for additional plans and instruments must be requested in writing.

SUPPLEMENTARY INFORMATION: This proposed information collection was previously published in the **Federal Register** on November 14, 2023, page 78053 (88 FR 78053) and allowed 60 days for public comment. No public comments were received. The purpose of this notice is to allow an additional 30 days for public comment. The National Cancer Institute (NCI), National Institutes of Health, may not conduct or sponsor, and the respondent is not required to respond to, an information collection that has been extended, revised, or implemented on or after October 1, 1995, unless it displays a currently valid OMB control number.

In compliance with section 3507(a)(1)(D) of the Paperwork Reduction Act of 1995, the National Institutes of Health (NIH) has submitted to the Office of Management and Budget (OMB) a request for review and approval of the information collection listed below.

Proposed Collection Title: Cancer Therapy Evaluation Program (CTEP) Branch and Support Contracts Forms and Surveys (NCI), 0925-0753, Expiration Date 03/31/2026, REVISION,

National Cancer Institute (NCI),
National Institutes of Health (NIH).

Need and Use of Information

Collection: This is a request for OMB to approve the revised information collection, Cancer Therapy Evaluation Program (CTEP) Support Contracts Forms and Survey. It includes modifications to OMB-approved forms for the CTSU and CIRB and the addition of new forms for the CTSU, CIRB, and CTEP. The National Cancer Institute (NCI) CTEP and the Division of Cancer Prevention (DCP) fund an extensive national program of cancer research, sponsoring clinical trials in cancer prevention, symptom management, and treatment for qualified clinical investigators. As part of this effort,

CTEP implements programs to register clinical site investigators and clinical site staff and to oversee the conduct of research at the clinical sites. CTEP and DCP also oversee two support programs, the NCI Central Institutional Review Board (CIRB) and the Cancer Trial Support Unit (CTSU). The combined systems and processes for initiating and managing clinical trials are termed the Clinical Oncology Research Enterprise (CORE) and represent an integrated set of information systems and processes that support investigator registration, trial oversight, patient enrollment, and clinical data collection. The information collected is required to ensure compliance with applicable federal

regulations governing the conduct of human subjects' research (45 CFR 46 and 21 CFR 50), and when CTEP acts as the Investigational New Drug (IND) holder (Food and Drug Administration (FDA) regulations pertaining to the sponsor of clinical trials and the selection of qualified investigators under 21 CFR 312.53). Survey collections assess satisfaction and provide feedback to guide improvements with processes and technology.

OMB approval is requested for 3 years. There are no costs to respondents other than their time. The total estimated annualized burden hours are 162,831 hours.

ESTIMATED ANNUALIZED BURDEN HOURS

Form name	Type of respondent	Number of respondents	Number of responses per respondent	Average burden per response (in hours)	Total annual burden hours
CTSU IRB/Regulatory Approval Transmittal Form (Attachment A01).	Health Care Practitioner	2,444	12	2/60	978
CTSU IRB Certification Form (Attachment A02).	Health Care Practitioner	2,444	12	10/60	4,888
Withdrawal from Protocol Participation Form (Attachment A03).	Health Care Practitioner	279	1	10/60	47
Site Addition Form (Attachment A04)	Health Care Practitioner	80	12	10/60	160
CTSU Request for Clinical Brochure (Attachment A06).	Health Care Practitioner	360	1	10/60	60
CTSU Supply Request Form (Attachment A07).	Health Care Practitioner	90	12	10/60	180
RTOG 0834 CTSU Data Transmittal Form (Attachment A10).	Health Care Practitioner	30	2	5/60	5
CTSU Patient Enrollment Transmittal Form (Attachment A15).	Health Care Practitioner	12	12	10/60	24
CTSU Transfer Form (Attachment A16)	Health Care Practitioner	360	2	10/60	120
CTSU OPEN Rave Request Form (Attachment A18).	Health Care Practitioner	30	21	10/60	105
CTSU LPO Form Creation (Attachment A19)	Health Care Practitioner	5	2	120/60	20
CTSU Site Form Creation and PDF (Attachment A20).	Health Care Practitioner	400	10	30/60	2,000
CTSU PDF Signature Form (Attachment A21)	Health Care Practitioner	400	10	10/60	667
CTSU CLASS Course Setup Request Form (Attachment A22).	Health Care Practitioner	10	2	20/60	7
CTSU LPO Approval of Early Closure Form (Attachment A23).	Health Care Practitioner	2,444	6	20/60	4,888
International DTL Signing (Attachment 24) ...	Health Care Practitioner	29	1	10/60	5
NCI CIRB AA & DOR between the NCI CIRB and Signatory Institution (Attachment B01).	Participants	50	1	15/60	13
NCI CIRB Signatory Enrollment Form (Attachment B02).	Participants	50	1	15/60	13
CIRB Board Member Application (Attachment B03).	Board Member	100	1	30/60	50
CIRB Member COI Screening Worksheet (Attachment B08).	Board Members	100	1	15/60	25
CIRB COI Screening for CIRB meetings (Attachment B09).	Board Members	72	1	15/60	18
CIRB IR Application (Attachment B10)	Health Care Practitioner	80	1	60/60	80
CIRB IR Application for Exempt Studies (Attachment B11).	Health Care Practitioner	4	1	30/60	2
CIRB Amendment Review Application (Attachment B12).	Health Care Practitioner	400	1	15/60	100
CIRB Ancillary Studies Application (Attachment B13).	Health Care Practitioner	1	1	60/60	1
CIRB Continuing Review Application (Attachment B14).	Health Care Practitioner	400	1	15/60	100

ESTIMATED ANNUALIZED BURDEN HOURS—Continued

Form name	Type of respondent	Number of respondents	Number of responses per respondent	Average burden per response (in hours)	Total annual burden hours
Adult IR of Cooperative Group Protocol (Attachment B15).	Board Members	65	1	180/60	195
Pediatric IR of Cooperative Group Protocol (Attachment B16).	Board Members	15	1	180/60	45
Adult Continuing Review of Cooperative Group Protocol (Attachment B17) Protocol.	Board Members	275	1	60/60	275
Adult Amendment of Cooperative Group Protocol (Attachment B19).	Board Members	40	1	120/60	80
Pediatric Amendment of Cooperative Group Protocol (Attachment B20).	Board Members	25	1	120/60	50
Pharmacist's Review of a Cooperative Group Study (Attachment B21).	Board Members	50	1	120/60	100
Adult Expedited Amendment Review (Attachment B23).	Board Members	348	1	30/60	174
Pediatric Expedited Amendment Review (Attachment B24).	Board Members	140	1	30/60	70
Adult Expedited Continuing Review (Attachment B25).	Board Members	140	1	30/60	70
Pediatric Expedited Continuing Review (Attachment B26).	Board Members	36	1	30/60	18
Adult Cooperative Group Response to CIRB Review (Attachment B27).	Health Care Practitioner	30	1	60/60	30
Pediatric Cooperative Group Response to CIRB Review (Attachment B28).	Health Care Practitioner	5	1	60/60	5
Adult Expedited Study Chair Response to Required Modifications (Attachment B29).	Board Members	40	1	30/60	20
Reviewer Worksheet—Determination of UP or SCN (Attachment B31).	Board Members	400	1	10/60	67
Reviewer Worksheet—CIRB Statistical Reviewer Form (Attachment B32).	Board Members	100	1	15/60	25
CIRB Application for Translated Documents (Attachment B33).	Health Care Practitioner	100	1	30/60	50
Reviewer Worksheet of Translated Documents (Attachment B34).	Board Members	100	1	15/60	25
Reviewer Worksheet of Recruitment Material (Attachment B35).	Board Members	20	1	15/60	5
Reviewer Worksheet Expedited Study Closure Review (Attachment B36).	Board Members	20	1	15/60	5
Reviewer Worksheet of Expedited IR (Attachment B38).	Board Members	5	1	30/60	3
Annual Signatory Institution Worksheet About Local Context (Attachment B40).	Health Care Practitioner	400	1	40/60	267
Annual Principal Investigator Worksheet About Local Context (Attachment B41).	Health Care Practitioner	1,800	1	20/60	600
Study-Specific Worksheet About Local Context (Attachment B42).	Health Care Practitioner	4,800	1	15/60	1,200
Study Closure or Transfer of Study Review Responsibility (Attachment B43).	Health Care Practitioner	1,680	1	15/60	420
Unanticipated Problem or Serious or Continuing Noncompliance Reporting Form (Attachment B44).	Health Care Practitioner	360	1	20/60	120
Change of Signatory Institution PI Form (Attachment B45).	Health Care Practitioner	120	1	20/60	40
Request Waiver of Assent Form (Attachment B46).	Health Care Practitioner	35	1	20/60	12
CIRB Waiver of Consent Request Supplemental Form (Attachment B47).	Health Care Practitioner	20	1	15/60	5
Review Worksheet CIRB Review for Inclusion of Incarcerated Participants (Attachment B48).	Board Members	20	1	60/60	20
Notification of Incarcerated Participant Form (Attachment B49).	Health Care Practitioner	20	1	20/60	7
Final Video Submission Posting Form (Attachment B50).	Health Care Practitioner	80	1	15/60	20
Unanticipated Problem or Serious or Continuing Noncompliance Application (Attachment B52).	Health Care Practitioner	20	1	30/60	10
CIRB Customer Satisfaction Survey (Attachment C04).	Participants	600	1	15/60	150

ESTIMATED ANNUALIZED BURDEN HOURS—Continued

Form name	Type of respondent	Number of respondents	Number of responses per respondent	Average burden per response (in hours)	Total annual burden hours
Follow-up Survey (Communication Audit) (Attachment C05).	Participants/Board Members ..	300	1	15/60	75
CIRB Board Member Annual Assessment Survey (Attachment C07).	Board Members	60	1	15/60	15
Audit Scheduling Form (Attachment D01)	Health Care Practitioner	229	5	21/60	401
Preliminary Audit Finding Form (Attachment D02).	Health Care Practitioner	229	5	10/60	191
Audit Maintenance Form (Attachment D03) ...	Health Care Practitioner	158	5	9/60	119
Final Audit Finding Report Form (Attachment D04).	Health Care Practitioner	110	11	1,098/60	22,143
Follow-up Form (Attachment D05)	Health Care Practitioner	44	7	27/60	139
Roster Maintenance Form (Attachment D06)	Health Care Practitioner	7	1	18/60	2
Final Report and CAPA Request Form (Attachment D07).	Health Care Practitioner	3	9	1,800/60	810
NCI/DCTD/CTEP FDA Form 1572 for Annual Submission (Attachment E01).	Physician	26,500	1	15/60	6,625
NCI/DCTD/CTE Biosketch (Attachment E02)	Physician; Health Care Practitioner.	48,000	1	120/60	96,000
NCI/DCTD/CTEP Financial Disclosure Form (Attachment E03).	Physician; Health Care Practitioner.	48,000	1	15/60	12,000
NCI/DCTD/CTEP Agent Shipment Form (ASF) (Attachment E04).	Physician	24,000	1	10/60	4,000
NINT Registration Form?	Health Care Practitioner, Other.	1,000	1	60/60	1,000
ISS Form	Physician	2,100	1	15/60	525
Basic Study Information Form (Attachment TBD).	Health Care Practitioner	140	1	20/60	47
Totals	173,463	253,510	162,831

Dated: March 5, 2024.

Diane Kreinbrink,

Project Clearance Liaison, National Cancer Institute, National Institutes of Health.

[FR Doc. 2024-04943 Filed 3-7-24; 8:45 am]

BILLING CODE 4140-01-P

DEPARTMENT OF HEALTH AND HUMAN SERVICES

National Institutes of Health

National Cancer Institute; Amended Notice of Meeting

Notice is hereby given of a change in the meeting of the National Cancer Institute Board of Scientific Advisors, March 19, 2024, 01:00 p.m. to March 20, 2024, 05:00 p.m., National Cancer Institute Shady Grove, 9609 Medical Center Drive, Bethesda, MD 20892 which was published in the **Federal Register** on February 27, 2024, FR Doc 2024-03914, 89 FR 14513.

This meeting notice is being amended to change the National Cancer Institute Board of Scientific Advisors (BSA) Meeting from a two-day meeting to a one-day meeting. The BSA Meeting will now be held on March 20, 2024, from 1:00 p.m. to 4:30 p.m. The BSA Meeting can be accessed from the NIH Videocast

at the following link: <https://videocast.nih.gov/>. The meeting is open to the public.

Dated: March 4, 2024.

Melanie J. Pantoja,

Program Analyst, Office of Federal Advisory Committee Policy.

[FR Doc. 2024-04933 Filed 3-7-24; 8:45 am]

BILLING CODE 4140-01-P

DEPARTMENT OF HEALTH AND HUMAN SERVICES

National Institutes of Health

Center for Scientific Review; Notice of Closed Meetings

Pursuant to section 1009 of the Federal Advisory Committee Act, as amended, notice is hereby given of the following meetings.

The meetings will be closed to the public in accordance with the provisions set forth in sections 552b(c)(4) and 552b(c)(6), title 5 U.S.C., as amended. The grant applications and the discussions could disclose confidential trade secrets or commercial property such as patentable material, and personal information concerning individuals associated with the grant applications, the disclosure of which

would constitute a clearly unwarranted invasion of personal privacy.

Name of Committee: Center for Scientific Review Special Emphasis Panel; Fellowships: Physiology and Pathobiology of Cardiovascular and Respiratory Systems: Respiratory.

Date: April 2-3, 2024.

Time: 10:00 a.m. to 8:00 p.m.

Agenda: To review and evaluate grant applications.

Place: National Institutes of Health, Rockledge II, 6701 Rockledge Drive, Bethesda, MD 20892 (Virtual Meeting).

Contact Person: Michael L. Bloom, Ph.D., Scientific Review Officer, Center for Scientific Review, National Institutes of Health, 6701 Rockledge Drive, Room 6187, MSC 7804, Bethesda, MD 20892, 301-451-0132, bloomm2@mail.nih.gov.

Name of Committee: Center for Scientific Review Special Emphasis Panel; RFA: HEAL Initiative Advanced Postdoctoral-to-Independent Career Transition Award in PAIN and SUD Research to Promote Diversity Review.

Date: April 2, 2024.

Time: 10:00 a.m. to 7:00 p.m.

Agenda: To review and evaluate grant applications.

Place: National Institutes of Health, Rockledge II, 6701 Rockledge Drive, Bethesda, MD 20892 (Virtual Meeting).

Contact Person: Katherine M. Malinda, Ph.D., Scientific Review Officer, Center for Scientific Review, National Institutes of Health, 6701 Rockledge Drive, Room 4140,

MSC 7814, Bethesda, MD 20892, (301) 435-0912, malindakm@csr.nih.gov.

Name of Committee: Center for Scientific Review Special Emphasis Panel; RFA-RM-23-006: 2024 Transformative Research Awards.

Date: April 2-3, 2024.

Time: 10:00 a.m. to 8:00 p.m.

Agenda: To review and evaluate grant applications.

Place: National Institutes of Health, Rockledge II, 6701 Rockledge Drive, Bethesda, MD 20892 (Virtual Meeting).

Contact Person: Sarita Kandula Sastry, Ph.D., Scientific Review Officer, Center for Scientific Review, National Institutes of Health, 6701 Rockledge Drive, Bethesda, MD 20782, 301-402-4788, sarita.sastry@nih.gov.

Name of Committee: Center for Scientific Review Special Emphasis Panel; RFA-RM-23-017: Human Virome Program: Characterization of functional interactions between viruses and human and microbial hosts (U01 Clinical Trial Not Allowed).

Date: April 2, 2024.

Time: 10:00 a.m. to 9:00 p.m.

Agenda: To review and evaluate grant applications.

Place: National Institutes of Health, Rockledge II, 6701 Rockledge Drive, Bethesda, MD 20892 (Virtual Meeting).

Contact Person: Kenneth A. Roebuck, Ph.D., Scientific Review Officer, Center for Scientific Review, National Institutes of Health, 6701 Rockledge Drive, Room 5214, MSC 7852, Bethesda, MD 20892, (301) 435-1166, roebuckk@csr.nih.gov.

Name of Committee: Center for Scientific Review Special Emphasis Panel; Special Topics in Instrumentation and System Development.

Date: April 2-3, 2024.

Time: 10:00 a.m. to 7:30 p.m.

Agenda: To review and evaluate grant applications.

Place: National Institutes of Health, Rockledge II, 6701 Rockledge Drive, Bethesda, MD 20892 (Virtual Meeting).

Contact Person: Yingli Fu, Ph.D., Scientific Review Officer, The Center for Scientific Review, The National Institutes of Health, 6701 Rockledge Drive, Bethesda, MD 20892, (301) 594-0840, yingli_fu@nih.gov.

Name of Committee: Center for Scientific Review Special Emphasis Panel; Topics in Urology.

Date: April 2, 2024.

Time: 2:30 p.m. to 5:30 p.m.

Agenda: To review and evaluate grant applications.

Place: National Institutes of Health, Rockledge II, 6701 Rockledge Drive, Bethesda, MD 20892 (Virtual Meeting).

Contact Person: Santanu Banerjee, Ph.D., Scientific Review Officer, Center for Scientific Review, National Institutes of Health, 6701 Rockledge Drive, Room 2106, Bethesda, MD 20892, (301) 435-5947, banerjees5@mail.nih.gov.

(Catalogue of Federal Domestic Assistance Program Nos. 93.306, Comparative Medicine; 93.333, Clinical Research, 93.306, 93.333, 93.337, 93.393-93.396, 93.837-93.844, 93.846-93.878, 93.892, 93.893, National Institutes of Health, HHS)

Dated: March 5, 2024.

Miguelina Perez,

Program Analyst, Office of Federal Advisory Committee Policy.

[FR Doc. 2024-05005 Filed 3-7-24; 8:45 am]

BILLING CODE 4140-01-P

DEPARTMENT OF HEALTH AND HUMAN SERVICES

National Institutes of Health

National Institute of Neurological Disorders and Stroke; Notice of Closed Meetings

Pursuant to section 1009 of the Federal Advisory Committee Act, as amended, notice is hereby given of the following meetings.

The meetings will be closed to the public in accordance with the provisions set forth in sections 552b(c)(4) and 552b(c)(6), title 5 U.S.C., as amended. The grant applications and the discussions could disclose confidential trade secrets or commercial property such as patentable material, and personal information concerning individuals associated with the grant applications, the disclosure of which would constitute a clearly unwarranted invasion of personal privacy.

Name of Committee: National Institute of Neurological Disorders and Stroke Special Emphasis Panel; Clinical Trial Readiness for Rare Neurological and Neuromuscular Diseases/Functional Neurological Disorders.

Date: April 2, 2024.

Time: 3:00 p.m. to 4:30 p.m.

Agenda: To review and evaluate grant applications.

Place: National Institutes of Health, Neuroscience Center, 6001 Executive Boulevard, Rockville, MD 20852.

Contact Person: Iqbal Sayeed, Ph.D., Scientific Review Officer, Scientific Review Branch, Division of Extramural Activities, NINDS/NIH/HHS NSC, 6001 Executive Blvd., Rockville, MD 20852, 301-496-9223, iqbal.sayeed@nih.gov.

Name of Committee: National Institute of Neurological Disorders and Stroke Special Emphasis Panel; ALS Expanded Access Clinical Trials.

Date: April 3, 2024.

Time: 10:00 a.m. to 3:00 p.m.

Agenda: To review and evaluate grant applications.

Place: National Institutes of Health, Neuroscience Center, 6001 Executive Boulevard, Rockville, MD 20852.

Contact Person: W. Ernest Lyons, Ph.D., Scientific Review Administrator, Scientific Review Branch, Division of Extramural Activities, NINDS/NIH/DHHS, NSC, 6001 Executive Blvd., Rockville, MD 20852, 301-496-4056, lyonse@ninds.nih.gov.

Name of Committee: National Institute of Neurological Disorders and Stroke Special Emphasis Panel; R13 Review.

Date: April 9, 2024.

Time: 11:00 a.m. to 5:00 p.m.

Agenda: To review and evaluate grant applications.

Place: National Institutes of Health, Neuroscience Center, 6001 Executive Boulevard, Rockville, MD 20852.

Contact Person: Li Jia, Ph.D., Scientific Review Officer, Scientific Review Branch, Division of Extramural Research, NINDS/NIH/HHS, NSC, 6001 Executive Blvd., Rockville, MD 20852, 301-451-2854, li.jia@nih.gov.

Name of Committee: National Institute of Neurological Disorders and Stroke Special Emphasis Panel; Phase 2 Clinical Trials in Neurology.

Date: April 9, 2024.

Time: 2:00 p.m. to 4:00 p.m.

Agenda: To review and evaluate grant applications.

Place: National Institutes of Health, Neuroscience Center, 6001 Executive Boulevard, Rockville, MD 20852.

Contact Person: Iqbal Sayeed, Ph.D., Scientific Review Officer, Scientific Review Branch, Division of Extramural Activities, NINDS/NIH/HHS, NSC, 6001 Executive Blvd., Rockville, MD 20852, 301-496-9223, iqbal.sayeed@nih.gov.

(Catalogue of Federal Domestic Assistance Program Nos. 93.853, Clinical Research Related to Neurological Disorders; 93.854, Biological Basis Research in the Neurosciences, National Institutes of Health, HHS.)

Dated: March 5, 2024.

Lauren A. Fleck,

Program Analyst, Office of Federal Advisory Committee Policy.

[FR Doc. 2024-05006 Filed 3-7-24; 8:45 am]

BILLING CODE 4140-01-P

DEPARTMENT OF HEALTH AND HUMAN SERVICES

Substance Abuse and Mental Health Services Administration

Advisory Committee for Women's Services (ACWS); Notice of Meeting

Pursuant to Public Law 92-463, notice is hereby given of two meetings of the Substance Abuse and Mental Health Services Administration's (SAMHSA) Advisory Committee for Women's Services (ACWS), including a subcommittee meeting of the Maternal Mental Health Task Force (MMHTF) on April 2, 2024 and April 17, 2024.

The meetings will include discussions on assessing SAMHSA's current strategies, including the mental health and substance use needs of the women and girls population. Additionally, the ACWS and MMHTF subcommittee will be addressing strategic initiatives and policy recommendations regarding Maternal Behavioral Health.

The meetings are open to the public and will be held virtually. Interested

persons may present data, information, or views, orally or in writing, on issues pending before the committee. Written submissions and oral presentations from the public should be coordinated with the contact person by March 22, 2024, for the meeting on April 2, 2024; and on April 8, 2024, for the meeting of April 17, 2024. Oral presentations from the public will be scheduled at the conclusion of the meeting during the Public Comment section. Up to five minutes will be allotted for each presentation and as time permits, as these are presented in a first come first serve basis. All oral and written comments will become part of the meeting's official records.

The meetings may be accessed via telephone or web meeting. To obtain the call-in number and access code, submit written or brief oral comments, or request special accommodations for persons with disabilities, please register on-line at: <https://snacregister.samhsa.gov/> or communicate with SAMHSA's Designated Federal Officer, Ms. Valerie Kolick.

Substantive meeting information and a roster of ACWS members may be obtained either by accessing the SAMHSA Committees' Web <https://www.samhsa.gov/about-us/advisory-councils/acws> or by contacting Ms. Kolick.

Committee Name: Substance Abuse and Mental Health Services Administration, Advisory Committee for Women's Services (ACWS).

Date/Time/Type: Tuesday, April 2, 2024, from 9 a.m. to 4:30 p.m. ET (OPEN); Wednesday, April 17, 2024, from 11 a.m. to 3:30 p.m. ET (OPEN).

Place: SAMHSA, 5600 Fishers Lane, Rockville, MD 20857.

Contact: Valerie Kolick, Designated Federal Officer, SAMHSA's Advisory Committee for Women's Services, 5600 Fishers Lane, Rockville, MD 20857, Telephone: (240) 276-1738, Email: Valerie.kolick@samhsa.hhs.gov.

Dated: March 4, 2024.

Carlos Castillo,

Committee Management Officer.

[FR Doc. 2024-04936 Filed 3-7-24; 8:45 am]

BILLING CODE 4162-20-P

DEPARTMENT OF HOMELAND SECURITY

Coast Guard

[Docket No. USCG-2024-0047]

Information Collection Request to Office of Management and Budget; OMB Control Number: 1625-0044

AGENCY: Coast Guard, DHS.

ACTION: Sixty-day notice requesting comments.

SUMMARY: In compliance with the Paperwork Reduction Act of 1995, the U.S. Coast Guard intends to submit an Information Collection Request (ICR) to the Office of Management and Budget (OMB), Office of Information and Regulatory Affairs (OIRA), requesting an extension of its approval for the following collection of information: 1625-0044, Outer Continental Shelf Activities—Title 33 CFR Subchapter N; without change. Our ICR describes the information we seek to collect from the public. Before submitting this ICR to OIRA, the Coast Guard is inviting comments as described below.

DATES: Comments must reach the Coast Guard on or before May 7, 2024.

ADDRESSES: You may submit comments identified by Coast Guard docket number [USCG-2024-0047] to the Coast Guard using the Federal eRulemaking Portal at <https://www.regulations.gov>. See the "Public participation and request for comments" portion of the **SUPPLEMENTARY INFORMATION** section for further instructions on submitting comments.

A copy of the ICR is available through the docket on the internet at <https://www.regulations.gov>. Additionally, copies are available from: Commandant (CG-6P), Attn: Paperwork Reduction Act Manager, U.S. Coast Guard, 2703 Martin Luther King Jr. Ave. SE, Stop 7710, Washington, DC 20593-7710.

FOR FURTHER INFORMATION CONTACT: A.L. Craig, Office of Privacy Management, telephone 202-475-3528, or fax 202-372-8405, for questions on these documents.

SUPPLEMENTARY INFORMATION:

Public Participation and Request for Comments

This notice relies on the authority of the Paperwork Reduction Act of 1995; 44 U.S.C. 3501 *et seq.*, chapter 35, as amended. An ICR is an application to OIRA seeking the approval, extension, or renewal of a Coast Guard collection of information (Collection). The ICR contains information describing the Collection's purpose, the Collection's

likely burden on the affected public, an explanation of the necessity of the Collection, and other important information describing the Collection. There is one ICR for each Collection.

The Coast Guard invites comments on whether this ICR should be granted based on the Collection being necessary for the proper performance of Departmental functions. In particular, the Coast Guard would appreciate comments addressing: (1) the practical utility of the Collection; (2) the accuracy of the estimated burden of the Collection; (3) ways to enhance the quality, utility, and clarity of information subject to the Collection; and (4) ways to minimize the burden of the Collection on respondents, including the use of automated collection techniques or other forms of information technology.

In response to your comments, we may revise this ICR or decide not to seek an extension of approval for the Collection. We will consider all comments and material received during the comment period.

We encourage you to respond to this request by submitting comments and related materials. Comments must contain the OMB Control Number of the ICR and the docket number of this request, [USCG-2024-0047], and must be received by May 7, 2024.

Submitting Comments

We encourage you to submit comments through the Federal eRulemaking Portal at <https://www.regulations.gov>. If your material cannot be submitted using <https://www.regulations.gov>, contact the person in the **FOR FURTHER INFORMATION CONTACT** section of this document for alternate instructions. Documents mentioned in this notice, and all public comments, are in our online docket at <https://www.regulations.gov> and can be viewed by following that website's instructions. Additionally, if you go to the online docket and sign up for email alerts, you will be notified when comments are posted.

We accept anonymous comments. All comments received will be posted without change to <https://www.regulations.gov> and will include any personal information you have provided. For more about privacy and submissions in response to this document, see DHS's eRulemaking System of Records notice (85 FR 14226, March 11, 2020).

Information Collection Request

Title: Outer Continental Shelf Activities—Title 33 CFR Subchapter N.
OMB Control Number: 1625-0044.

Summary: The Outer Continental Shelf Lands Act, as amended, authorizes the Coast Guard to promulgate and enforce regulations promoting the safety of life and property on Outer Continental Shelf (OCS) facilities. These regulations are located in 33 CFR subchapter N.

Need: The information is needed to ensure compliance with the safety regulations related to OCS activities. The regulations contain reporting and recordkeeping requirements for annual inspections of OCS facilities, employee citizenship records, station bills, and emergency evacuation plans.

Forms:

- CG-5432, Fixed OCS Facility Inspection Report.

Respondents: Operators of facilities and vessels engaged in activities on the OCS.

Frequency: On occasion.

Hour Burden Estimate: The estimated burden has decreased from 9,582 hours to 9,578 hours a year, due to a decrease in the estimated annual number of responses.

Authority: The Paperwork Reduction Act of 1995; 44 U.S.C. chapter 35, as amended.

Dated: February 22, 2024.

Kathleen Claffie,

Chief, Office of Privacy Management, U.S. Coast Guard.

[FR Doc. 2024-04950 Filed 3-7-24; 8:45 am]

BILLING CODE 9110-04-P

DEPARTMENT OF THE INTERIOR

Bureau of Indian Affairs

[245A2100DD/AAKC001030/
AOA501010.999900]

Notice of Intent to Prepare an Environmental Impact Statement for the Koi Nation's Proposed Shiloh Resort and Casino Project, Sonoma County, California

AGENCY: Bureau of Indian Affairs, Interior.

ACTION: Notice.

SUMMARY: This notice advises the public that the Bureau of Indian Affairs (BIA), as lead agency, intends to gather information necessary for preparing an Environmental Impact Statement (EIS) pursuant to the National Environmental Policy Act (NEPA) in connection with the Koi Nation's (Nation) proposed Shiloh Resort and Casino Project adjacent to the Town of Windsor, Sonoma County, California for gaming and other purposes. Although a formal public scoping process has been

conducted and an Environmental Assessment (EA) circulated for this proposed Federal action, this notice also invites the public to identify potential issues, concerns, and alternatives to be considered in the EIS which have not previously been raised during this NEPA process.

DATES: To ensure consideration during the development of the EIS, written comments on the scope of the EIS should be sent as soon as possible and no later than 30 days after publication of this Notice of Intent (NOI) in the **Federal Register**.

ADDRESSES: You may mail written comments to Amy Dutschke, Regional Director, Bureau of Indian Affairs, Pacific Region, 2800 Cottage Way, Sacramento, California 95825. Please include your name, return address, and "NOI Comments, Koi Nation Fee-to-Trust and Casino Project" on the first page of your written comments. You may also submit comments through email to Chad Broussard, Environmental Protection Specialist, Bureau of Indian Affairs, at chad.broussard@bia.gov, using "NOI Comments, Koi Nation Fee-to-Trust and Casino Project" as the subject of your email.

FOR FURTHER INFORMATION CONTACT:

Chad Broussard, Environmental Protection Specialist, Bureau of Indian Affairs, Pacific Regional Office, 2800 Cottage Way, Room W—2820, Sacramento, California 95825; telephone: (916) 978-6000; email: chad.broussard@bia.gov.

SUPPLEMENTARY INFORMATION: The Koi Nation submitted a Fee-to-Trust application to the Bureau of Indian Affairs (BIA) requesting the placement of approximately 68.60 acres of fee land in trust by the United States as restored lands pursuant to 25 CFR part 292 upon which the Koi Nation would construct a casino resort. The Nation proposes to develop a casino-resort with ballroom/meeting space, event center, spa, and associated infrastructure. The proposed Fee-to-Trust property is located adjacent to the Town of Windsor, Sonoma County, California. The proposed trust property is assessor's parcels number 059-300-003. The purpose of the proposed action is to facilitate tribal self-sufficiency, self-determination, and economic development. The proposed action encompasses the various federal approvals that may be required to implement the Koi Nation's proposed project, including approval of the Koi Nation's land Fee-to-Trust application and Secretarial Determination pursuant to section 20 (b)(1)(B) of the Indian Gaming Regulatory Act (25 U.S.C. 2719 (b)(1)(B)(iii)).

The BIA previously prepared an EA that analyzed the potential environmental effects of the proposed action. The EA was made available for public comments and was the subject of a public meeting. Upon consideration of the public and agency comments received, the BIA has decided to prepare an EIS to further analyze the environmental effects which may result from the proposed action.

The EIS will identify and evaluate issues related to these approvals and will also evaluate a range of reasonable alternatives. Possible alternatives currently under consideration include: (1) a reduced-intensity casino alternative, (2) an alternate-use (non-gaming) alternative, and (3) a no-action alternative. The range of alternatives evaluated in the EIS may be expanded based on comments received during the scoping process. Areas of environmental concern preliminarily identified for analysis in the EIS include land resources; water resources; air quality; noise; biological resources; cultural and paleontological resources; transportation and circulation; land use; hazardous materials and hazards; public services and utilities; socioeconomic; environmental justice; visual resources; and cumulative, indirect, and growth-inducing effects.

The range of issues to be addressed in the EIS may be expanded or reduced based on comments received in response to this notice and in response to the previous publication of the EA. Additional information, including a map of the proposed trust property, is available at <https://shilohresortenvironmental.com> or by contacting the person listed in the **FOR FURTHER INFORMATION CONTACT** section of this notice.

Public Comment Availability: Comments, including names and addresses of respondents, will be included as part of the administrative record. Before including your address, telephone number, email address, or other personal identifying information in your comment, you should be aware that your entire comment—including your personal identifying information—may be made publicly available at any time. While you can ask in your comment that your personal identifying information be withheld from public review, the BIA cannot guarantee that this will occur.

Authority: This notice is published pursuant to section 1503.1 of the Council of Environmental Quality Regulations (40 CFR parts 1500 through 1508) and section 46.305 of the Department of the Interior Regulations (43 CFR part 46), implementing the

procedural requirements of the NEPA of 1969, as amended (42 U.S.C. 4371, *et seq.*), and in accordance with the exercise of authority delegated to the Assistant Secretary—Indian Affairs by 209 DM 8. This notice is also published in accordance with 40 CFR 93.155, which provides reporting requirements for conformity determinations.

Wizipan Garriott,

Principal Deputy Assistant Secretary—Indian Affairs, Exercising by Delegation the Authority of the Assistant Secretary—Indian Affairs.

[FR Doc. 2024-04937 Filed 3-7-24; 8:45 am]

BILLING CODE 4337-15-P

DEPARTMENT OF THE INTERIOR

National Park Service

[DOI-2023-0018; PPWOPFLL0/
PSSPPFL0088.00.1]

Privacy Act of 1974; System of Records

AGENCY: National Park Service, Interior.
ACTION: Notice of a modified system of records.

SUMMARY: Pursuant to the provisions of the Privacy Act of 1974, as amended, the Department of the Interior (DOI) is issuing a public notice of its intent to modify the National Park Service (NPS) Privacy Act system of records, INTERIOR/NPS-2, Land Acquisition and Relocation Files. DOI is revising this notice to expand the scope to include realty management activities; update the system name; propose new and modified routine uses; and update all sections to accurately reflect management of the system of records. This modified system will be included in DOI's inventory of record systems.
DATES: This modified system will be effective upon publication. New or modified routine uses will be effective April 8, 2024. Submit comments on or before April 8, 2024.

ADDRESSES: You may send comments identified by docket number [DOI-2023-0018] by any of the following methods:

- *Federal eRulemaking Portal:* <https://www.regulations.gov>. Follow the instructions for sending comments.

- *Email:* DOI_Privacy@ios.doi.gov. Include docket number [DOI-2023-0018] in the subject line of the message.

- *U.S. Mail or Hand-Delivery:* Teri Barnett, Departmental Privacy Officer, U.S. Department of the Interior, 1849 C Street NW, Room 7112, Washington, DC 20240.

Instructions: All submissions received must include the agency name and

docket number [DOI-2023-0018]. All comments received will be posted without change to <https://www.regulations.gov>, including any personal information provided.

Docket: For access to the docket to read background documents or comments received, go to <https://www.regulations.gov>.

FOR FURTHER INFORMATION CONTACT:

Felix Uribe, Associate Privacy Officer, National Park Service, 12201 Sunrise Valley Drive, Reston, VA 20192, nps_privacy@nps.gov or (202) 354-6925.

SUPPLEMENTARY INFORMATION:

I. Background

The NPS maintains the INTERIOR/NPS-2, Land Acquisition and Relocation Files, system of records. The mission of the NPS is to preserve the natural and cultural resources and values of the National Park system for the enjoyment, education, and inspiration of this and future generations. Land protection activities play a vital role in accomplishing these objectives within National Park units (often referred to as parks). The purpose of the system of records is to manage land acquisition, relocation, and realty management activities for lands or interests in lands associated with National Park units.

DOI is proposing to change the name of the system from INTERIOR/NPS-2, Land Acquisition and Relocation Files, to INTERIOR/NPS-2, Land Acquisition, Relocation, and Realty Management Records, to reflect the expanded scope of the system of records to include realty management activities. DOI is also updating the system location, category of records, category of individuals, records source categories, storage, retrieval, records retention and disposal, and safeguards; updating the authorities in accordance with the new Title 54 of the U.S. Code, which includes only laws applicable to NPS; updating the notification, records access and contesting procedures; adding new sections for security classification, purpose, and history of the system of records; and making general updates to the remaining sections to accurately reflect management of the system of records in accordance with the Office of Management and Budget (OMB) Circular A-108, *Federal Agency Responsibilities for Review, Reporting, and Publication under the Privacy Act*.

DOI is also changing the routine uses from a numeric to alphabetic list and is proposing to modify existing routine uses to provide clarity and transparency, and to reflect updates consistent with standard DOI routine

uses. Routine use A was modified to further clarify disclosures to the Department of Justice (DOJ) or other Federal agencies, when necessary, in relation to litigation or judicial hearings. Modified routine use B clarifies disclosures to a congressional office to respond to or resolve an individual's request made to that office. Modified routine use D allows DOI to refer matters to the appropriate Federal, State, local, or foreign agencies, or other public authority agencies responsible for investigating or prosecuting violations of, or for enforcing, or implementing, a statute, rule, regulation, order, or license. Modified routine use J and proposed routine use K allow DOI and NPS to share information with appropriate Federal agencies or entities when reasonably necessary to respond to a breach of personally identifiable information (PII) and to prevent, minimize, or remedy the risk of harm to individuals or the Federal Government, or assist an agency in locating individuals affected by a breach in accordance with OMB Memorandum M-17-12, *Preparing for and Responding to a Breach of Personally Identifiable Information*. Routine use P was modified to remove the reference to condemnation proceedings since the condemnation process is covered by routine use A and add clarifying reference to the regulations of the Attorney General for review of title for Federal land acquisitions.

DOI is proposing new routine uses to facilitate sharing of information with agencies and organizations to promote the integrity of the records in the system or carry out a statutory responsibility of the DOI or Federal Government. Proposed routine use C facilitates sharing of information with the Executive Office of the President to resolve issues concerning individuals' records. Proposed routine use E allows NPS to share information with other Federal agencies to assist in the performance of their responsibility to ensure records are accurate and complete, and to respond to requests from individuals who are the subject of the records. Proposed routine use F facilitates sharing of information related to hiring, issuance of a security clearance, or a license, contract, grant or benefit. Proposed routine use G allows NPS to share information with the National Archives and Records Administration (NARA) to conduct records management inspections. Proposed routine use H allows NPS to share information with external entities, such as State, territorial and local

governments, and Tribal organizations needed in response to court orders and/or for discovery purposes related to litigation. Proposed routine use I facilitates sharing of information with an expert, consultant, grantee, shared service provider, or contractor when authorized and necessary to perform services on DOI's behalf to carry out the purposes of the system. Proposed routine use L facilitates sharing with the OMB in relation to legislative affairs mandated by OMB Circular A-19. Proposed routine use M allows NPS to share information with the Department of the Treasury to recover debts owed to the United States. Proposed routine use N allows NPS to share information with the news media and the public if there is a legitimate public interest in the disclosure of the information. Proposed routine use Q allows NPS to share information with other Federal agencies, Federal entities, State, territorial, and local governments, Tribal organizations, and nonprofit partners on land acquisition, relocation, or realty management projects. Proposed routine use R facilitates sharing of information when authorized and necessary for land acquisition, relocation, or realty management projects.

II. Privacy Act

The Privacy Act of 1974, as amended, embodies fair information practice principles in a statutory framework governing the means by how Federal agencies collect, maintain, use, and disseminate individuals' records. The Privacy Act applies to records about individuals that are maintained in a "system of records." A "system of records" is a group of any records under the control of an agency from which information is retrieved by the name of an individual or by some identifying number, symbol, or other identifying particular assigned to the individual. The Privacy Act defines an individual as a United States citizen or lawful permanent resident. Individuals may request access to their own records that are maintained in a system of records in the possession or under the control of DOI by complying with DOI Privacy Act regulations at 43 CFR part 2, subpart K, and following the procedures outlined in the Records Access, Contesting Record, and Notification Procedures sections of this notice.

The Privacy Act requires each agency to publish in the **Federal Register** a description denoting the existence and character of each system of records that the agency maintains, and the routine uses of each system. The INTERIOR/NPS-2, Land Acquisition, Relocation, and Realty Management Records,

system of records notice is published in its entirety below. In accordance with 5 U.S.C. 552a(r), DOI has provided a report of this system of records to the Office of Management and Budget and to Congress.

III. Public Participation

You should be aware your entire comment including your personally identifiable information, such as your address, phone number, email address, or any other personal information in your comment, may be made publicly available at any time. While you may request to withhold your personally identifiable information from public review, we cannot guarantee we will be able to do so.

SYSTEM NAME AND NUMBER:

INTERIOR/NPS-2, Land Acquisition, Relocation, and Realty Management Records.

SECURITY CLASSIFICATION:

Unclassified.

SYSTEM LOCATION:

National Program Center, Land Resources Division, National Park Service, U.S. Department of the Interior, 1849 C Street NW, Washington, DC 20240. Records are also located at Project Offices and Regional Land Offices involved with land acquisition, relocation, and realty management activities. A current listing of these offices may be obtained by writing to the System Manager.

SYSTEM MANAGER(S):

Chief, National Program Center, Land Resources Division, National Park Service, U.S. Department of the Interior, 1849 C Street NW, Washington, DC 20240.

AUTHORITY FOR MAINTENANCE OF THE SYSTEM:

Title 54, United States Code, National Park Service and Related Programs; 44 U.S.C. 3101, Records management by agency heads; general duties; and 42 U.S.C. 4651, Uniform policy on real property acquisition practices.

PURPOSE(S) OF THE SYSTEM:

The purpose of the system is to help NPS manage land acquisition, relocation, and realty management activities across lands associated with National Park units.

CATEGORIES OF INDIVIDUALS COVERED BY THE SYSTEM:

Current and former landowners, tenants, permittees, and other entities with an interest in lands associated with a National Park unit.

CATEGORIES OF RECORDS IN THE SYSTEM:

This system contains records on:

(1) Deeds, title evidence such as easements and title policies, right-of-way permits, agreements, correspondence, notes, maps, surveys, tracts, and memoranda pertinent to land acquisition, relocation, and realty management projects across lands associated with a National Park unit. These records may contain information that includes names, home addresses, personal telephone numbers, email addresses of private individuals, such as landowners, tenants, or permittees that are involved in a project. Records are organized by tract number, instrument number, or landowner name.

(2) Private individuals receiving payments for land acquisition or relocation activities that may contain personal or financial information, including Taxpayer Identification Number, Social Security number, or bank account numbers to ensure payments are successfully made to the correct individual.

RECORD SOURCE CATEGORIES:

Information in this system is obtained from title companies, public records, mapping contractors, survey contractors, contract appraisers, environmental site assessors, landowners and permittees.

ROUTINE USES OF RECORDS MAINTAINED IN THE SYSTEM, INCLUDING CATEGORIES OF USERS AND PURPOSES OF SUCH USES:

In addition to those disclosures generally permitted under 5 U.S.C. 552a(b) of the Privacy Act, all or a portion of the records or information contained in this system may be disclosed outside DOI as a routine use pursuant to 5 U.S.C. 552a(b)(3) as follows:

A. To the Department of Justice (DOJ), including Offices of the U.S. Attorneys, or other Federal agency conducting litigation or in proceedings before any court, adjudicative, or administrative body, when it is relevant or necessary to the litigation and one of the following is a party to the litigation or has an interest in such litigation:

- (1) DOI or any component of DOI;
- (2) Any other Federal agency appearing before the Office of Hearings and Appeals;
- (3) Any DOI employee or former employee acting in his or her official capacity;
- (4) Any DOI employee or former employee acting in his or her individual capacity when DOI or DOJ has agreed to represent that employee or pay for private representation of the employee; or

(5) The United States Government or any agency thereof when DOI determines that DOI is likely to be affected by the proceeding.

B. To a congressional office when requesting information on behalf of, and at the request of, the individual who is the subject of the record.

C. To the Executive Office of the President in response to an inquiry from that office made at the request of the subject of a record or a third party on that person's behalf, or for a purpose compatible with the reason for which the records are collected or maintained.

D. To any criminal, civil, or regulatory law enforcement authority (whether Federal, State, territorial, local, Tribal or foreign) when a record, either alone or in conjunction with other information, indicates a violation or potential violation of law—criminal, civil, or regulatory in nature, and the disclosure is compatible with the purpose for which the records were compiled.

E. To an official of another Federal agency to provide information needed in the performance of official duties related to reconciling or reconstructing data files or to enable that agency to respond to an inquiry by the individual to whom the record pertains.

F. To Federal, State, territorial, local, Tribal, or foreign agencies that have requested information relevant or necessary to the hiring, firing or retention of an employee or contractor, or the issuance of a security clearance, license, contract, grant or other benefit, when the disclosure is compatible with the purpose for which the records were compiled.

G. To representatives of the National Archives and Records Administration (NARA) to conduct records management inspections under the authority of 44 U.S.C. 2904 and 2906.

H. To State, territorial, and local governments and Tribal organizations to provide information needed in response to court order and/or discovery purposes related to litigation, when the disclosure is compatible with the purpose for which the records were compiled.

I. To an expert, consultant, grantee, shared service provider, or contractor (including employees of the contractor) of DOI that performs services requiring access to these records on DOI's behalf to carry out the purposes of the system.

J. To appropriate agencies, entities, and persons when:

(1) DOI suspects or has confirmed that there has been a breach of the system of records;

(2) DOI has determined that as a result of the suspected or confirmed breach there is a risk of harm to individuals,

DOI (including its information systems, programs, and operations), the Federal Government, or national security; and

(3) the disclosure made to such agencies, entities, and persons is reasonably necessary to assist in connection with DOI's efforts to respond to the suspected or confirmed breach or to prevent, minimize, or remedy such harm.

K. To another Federal agency or Federal entity, when DOI determines that information from this system of records is reasonably necessary to assist the recipient agency or entity in:

(1) responding to a suspected or confirmed breach; or

(2) preventing, minimizing, or remedying the risk of harm to individuals, the recipient agency or entity (including its information systems, programs, and operations), the Federal Government, or national security, resulting from a suspected or confirmed breach.

L. To the Office of Management and Budget (OMB) during the coordination and clearance process in connection with legislative affairs as mandated by OMB Circular A-19.

M. To the Department of the Treasury to recover debts owed to the United States.

N. To the news media and the public, with the approval of the Public Affairs Officer in consultation with counsel and the Senior Agency Official for Privacy, where there exists a legitimate public interest in the disclosure of the information, except to the extent it is determined that release of the specific information in the context of a particular case would constitute an unwarranted invasion of personal privacy.

O. To authorized title companies and closing agents for title policies and closings.

P. To the United States Department of Justice for preliminary and final title opinions as required by the regulations of the Attorney General governing the review and approval of title for Federal land acquisitions.

Q. To other Federal agencies and entities, State, territorial, and local governments, Tribal organizations, and nonprofit partners working in conjunction with the NPS on land acquisition, relocation, or realty management projects.

R. To members of the public when statute or regulation requires that a Federal realty action be accompanied by a public notification detailing the parties and lands involved.

POLICIES AND PRACTICES FOR STORAGE OF RECORDS:

Paper records are contained in file folders and stored in locked filing cabinets and file rooms in secure DOI controlled facilities. Electronic records are contained in computers, email, network storage devices, and electronic databases.

POLICIES AND PRACTICES FOR RETRIEVAL OF RECORDS:

Records are indexed and retrieved by an individual's name or by a unique identifier, such as a tract or instrument number.

POLICIES AND PRACTICES FOR RETENTION AND DISPOSAL OF RECORDS:

Records are retained in perpetuity in accordance with the NPS Records Schedule Resource Management and Lands (Item 1) (N1-79-08-1), which was approved by NARA. Once projects are completed, the paper records are transferred to NARA for permanent storage. Electronic records remain accessible to authorized NPS staff for ongoing park management purposes.

ADMINISTRATIVE, TECHNICAL, AND PHYSICAL SAFEGUARDS:

The records contained in this system are safeguarded in accordance with 43 CFR 2.226 and other applicable security and privacy rules and policies. Paper records are under the control of authorized personnel and stored within secured filing cabinets and file rooms. The desktop computers and servers on which electronic records reside are in secured DOI controlled facilities with physical, technical, and administrative levels of security to prevent unauthorized access to the DOI network and information assets. Electronic records on laptop computers are protected with data-at-rest encryption on their hard drives. Access to the electronic records requires successful network authentication and is limited to personnel who have a need to know the information for the performance of their official duties.

Computerized records systems follow the National Institute of Standards and Technology privacy and security standards as developed to comply with the Privacy Act of 1974, as amended, 5 U.S.C. 552a; Paperwork Reduction Act of 1995, 44 U.S.C. 3501 *et seq.*; Federal Information Security Modernization Act of 2014, 44 U.S.C. 3551 *et seq.*; and the Federal Information Processing Standards 199: Standards for Security Categorization of Federal Information and Information Systems. Security controls include multi-factor user authentication, passwords, database permissions, encryption, firewalls, audit

logs, and network system security monitoring, and software controls. System backups are stored in a locked and controlled room in a secure, off-site location.

A Privacy Act Warning Notice appears on computer monitor screens when records containing information on individuals are made available to authorized personnel. System administrators and authorized users are trained and required to follow established internal security protocols and must complete all security, privacy, and records management training and sign the DOI Rules of Behavior.

RECORD ACCESS PROCEDURES:

An individual requesting records access to their records should send a written inquiry to the System Manager identified above. DOI forms and instructions for submitting a Privacy Act request may be obtained from the DOI Privacy Act Requests website at <https://www.doi.gov/privacy/privacy-act-requests>. The request must include a general description of the records sought and the requester's full name, current address, and sufficient identifying information such as date of birth or other information required for verification of the requester's identity. The request must be signed and dated and be either notarized or submitted under penalty of perjury in accordance with 28 U.S.C. 1746. Requests submitted by mail must be marked "PRIVACY ACT REQUEST FOR ACCESS" on both the envelope and letter. A request for access must meet the requirements of 43 CFR 2.238.

CONTESTING RECORD PROCEDURES:

An individual requesting amendment of their records should send a written request to the System Manager identified above. DOI instructions for submitting a request for amendment of records are available on the DOI Privacy Act Request website at <https://www.doi.gov/privacy/privacy-act-requests>. The request must clearly identify the records for which amendment is being sought, the reasons for requesting the amendment, and the proposed amendment to the record. The request must include the requester's full name, current address, and sufficient identifying information such as date of birth or other information required for verification of the requester's identity. The request must be signed and dated and be either notarized or submitted under penalty of perjury in accordance with 28 U.S.C. 1746. Requests submitted by mail must be clearly marked "PRIVACY ACT REQUEST FOR AMENDMENT" on both the envelope

and letter. A request for amendment must meet the requirement of 43 CFR 2.246.

NOTIFICATION PROCEDURES:

An individual requesting notification of the existence of records about them should send a signed, written inquiry to the System Manager identified above. DOI instructions for submitting a request for notification are available on the DOI Privacy Act Requests website at <https://www.doi.gov/privacy/privacy-act-requests>. The request must include a general description of the records and the requester's full name, current address, and sufficient identifying information such as date of birth or other information required for verification of the requester's identity. The request must be signed and dated and be either notarized or submitted under penalty of perjury in accordance with 28 U.S.C. 1746. Requests submitted by mail must be clearly marked "PRIVACY ACT INQUIRY" on both the envelope and letter. A request for notification must meet the requirements of 43 CFR 2.235.

EXEMPTIONS PROMULGATED FOR THE SYSTEM:

None.

HISTORY:

48 FR 51696 (November 10, 1983); modification published at 73 FR 63992 (October 28, 2008).

Teri Barnett,

Departmental Privacy Officer, U.S. Department of the Interior.

[FR Doc. 2024-04976 Filed 3-7-24; 8:45 am]

BILLING CODE 4312-52-P

DEPARTMENT OF THE INTERIOR

National Park Service

[NPS-WASO-NAGPRA-NPS0037559; PPWOCRADNO-PCU00RP14.R50000]

Notice of Inventory Completion: University of Oregon Museum of Natural and Cultural History, Eugene, OR

AGENCY: National Park Service, Interior.

ACTION: Notice.

SUMMARY: In accordance with the Native American Graves Protection and Repatriation Act (NAGPRA), the University of Oregon Museum of Natural and Cultural History has completed an inventory of human remains and associated funerary objects and has determined that there is a cultural affiliation between the human remains and associated funerary objects and Indian Tribes or Native Hawaiian

organizations in this notice. The human remains and associated funerary objects were removed from Bristol Bay Borough, AK.

DATES: Repatriation of the human remains and associated funerary objects in this notice may occur on or after April 8, 2024.

ADDRESSES: Dr. Pamela Endzweig, Director of Anthropological Collections, University of Oregon Museum of Natural and Cultural History, 1224 University of Oregon, Eugene, OR 97403-1224, telephone (541) 346-5120, email endzweig@uoregon.edu.

SUPPLEMENTARY INFORMATION: This notice is published as part of the National Park Service's administrative responsibilities under NAGPRA. The determinations in this notice are the sole responsibility of the University of Oregon Museum of Natural and Cultural History. The National Park Service is not responsible for the determinations in this notice. Additional information on the determinations in this notice, including the results of consultation, can be found in the inventory or related records held by the University of Oregon Museum of Natural and Cultural History.

Description

In 1983, human remains representing, at minimum, one individual were removed from Bristol Bay Borough, Naknek River, AK. The human remains were transferred to the Museum of Natural and Cultural History by a former University of Oregon archeologist, who collected them on July 29, 1983. The fragmentary human remains are from a female adult, 30-50 years of age. No associated funerary objects are present.

In 1973 or 1974, human remains representing, at minimum, one individual were removed from Bristol Bay Borough, AK. The human remains (burial Nak2B1; catalog number 11-444)—a male between 30-45 years of age—were collected from the Paugvik Site (49Nak2) during legally authorized archeological excavations by a University of Oregon field party. The 35 associated funerary objects are two shaped bones, two slate flakes, one miniature sled runner, one bone awl, one pick-pryer, one slate scraper, one lot of wood from tomb, one copper box, one rib tool, one lot of grass matting, one skull impression, one potsherd, 11 pieces of hematite, four bark cloth fragments, one lot of hair, one lot of hide fragments, and four lots of mixed hair, matting, hide, cloth, and leather.

In 1973 or 1974, human remains representing, at minimum, one individual were removed from Bristol

Bay Borough, AK. The human remains (burial Nak2B2; catalog number 11–445)—a female between 20–30 years of age—were collected from the Paugvik Site (49Nak2) during legally authorized archeological excavations by a University of Oregon field party. The 26 associated funerary objects are one lot of potsherds, one smoothed rock, two socket pieces, one lot glass beads, one slate blade fragment, two sewn hides, 12 hide fragments, one mukluk, four pieces of leather, and one abrader.

In 1973 or 1974, human remains representing, at minimum, one individual were removed from Bristol Bay Borough, AK. The human remains (burial Nak2B3; catalog number 11–446)—a female between 15–20 years of age—were collected from the Paugvik Site (49Nak2) during legally authorized archeological excavations by a University of Oregon field party. The one associated funerary object is one lot of glass beads.

In 1973 or 1974, human remains representing, at minimum, two individuals were removed from Bristol Bay Borough, AK. The human remains (burial Nak2B4, catalog number 11–447)—one adult male between 30–40 years of age and one individual of indeterminate age and sex—were collected from the Paugvik Site (49Nak2) during legally authorized archeological excavations by a University of Oregon field party. The one associated funerary object is a wooden tray.

In 1973 or 1974, human remains representing, at minimum, one individual were removed from Bristol Bay Borough, AK. The human remains (burial Nak2B5, catalog number 11–448)—an adult male between 30–40 years of age—were collected from the Paugvik Site (49Nak2) during legally authorized archeological excavations by a University of Oregon field party. It is uncertain whether the wooden tray listed for the previous burial is associated with Nak2B4 or Nak2B5.

According to published materials, all burials from the Paugvik Site are assigned to the Pavik Phase, ca. 1800–1900 CE, on the basis of association with European trade goods or stratigraphic context.

Cultural Affiliation

The human remains and associated funerary objects in this notice are connected to one or more identifiable earlier groups, tribes, peoples, or cultures. There is a relationship of shared group identity between the identifiable earlier groups, tribes, peoples, or cultures and one or more Indian Tribes or Native Hawaiian

organizations. The following types of information were used to reasonably trace the relationship: anthropological information; archeological information; geographical information.

Determinations

Pursuant to NAGPRA and its implementing regulations, and after consultation with the appropriate Indian Tribes and Native Hawaiian organizations, the University of Oregon Museum of Natural and Cultural History has determined that:

- The human remains described in this notice represent the physical remains of seven individuals of Native American ancestry.

- The 63 objects described in this notice are reasonably believed to have been placed with or near individual human remains at the time of death or later as part of the death rite or ceremony.

- There is a relationship of shared group identity that can be reasonably traced between the human remains and associated funerary objects described in this notice and the Naknek Native Village.

Requests for Repatriation

Written requests for repatriation of the human remains and associated funerary objects in this notice must be sent to the Responsible Official identified in **ADDRESSES**. Requests for repatriation may be submitted by:

1. Any one or more of the Indian Tribes or Native Hawaiian organizations identified in this notice.
2. Any lineal descendant, Indian Tribe, or Native Hawaiian organization not identified in this notice who shows, by a preponderance of the evidence, that the requestor is a lineal descendant or a culturally affiliated Indian Tribe or Native Hawaiian organization.

Repatriation of the human remains and associated funerary objects in this notice to a requestor may occur on or after April 8, 2024. If competing requests for repatriation are received, the University of Oregon Museum of Natural and Cultural History must determine the most appropriate requestor prior to repatriation. Requests for joint repatriation of the human remains and associated funerary objects are considered a single request and not competing requests. The University of Oregon Museum of Natural and Cultural History is responsible for sending a copy of this notice to the Indian Tribes and Native Hawaiian organizations identified in this notice.

This notice was submitted before the effective date of the revised regulations (88 FR 86452, December 13, 2023,

effective January 12, 2024). As the notice conforms to the mandatory format of the **Federal Register** and includes the required information, the National Park Service is publishing this notice as submitted.

Authority: Native American Graves Protection and Repatriation Act, 25 U.S.C. 3003, and the implementing regulations, 43 CFR 10.10.

Dated: February 29, 2024.

Melanie O'Brien,

Manager, National NAGPRA Program.

[FR Doc. 2024–04985 Filed 3–7–24; 8:45 am]

BILLING CODE 4312–52–P

DEPARTMENT OF THE INTERIOR

National Park Service

[NPS–WASO–NAGPRA–NPS0037561; PPWOCRADNO–PCU00RP14.R50000]

Notice of Inventory Completion: University of Oregon Museum of Natural and Cultural History, Eugene, OR

AGENCY: National Park Service, Interior.

ACTION: Notice.

SUMMARY: In accordance with the Native American Graves Protection and Repatriation Act (NAGPRA), the University of Oregon Museum of Natural and Cultural History has completed an inventory of human remains and has determined that there is a cultural affiliation between the human remains and Indian Tribes or Native Hawaiian organizations in this notice. The human remains were removed from Harney County, OR.

DATES: Repatriation of the human remains in this notice may occur on or after April 8, 2024.

ADDRESSES: Dr. Pamela Endzweig, Director of Anthropological Collections, University of Oregon Museum of Natural and Cultural History, 1224 University of Oregon, Eugene, OR 97403–1224, telephone (541) 346–5120, email endzweig@uoregon.edu.

SUPPLEMENTARY INFORMATION: This notice is published as part of the National Park Service's administrative responsibilities under NAGPRA. The determinations in this notice are the sole responsibility of the University of Oregon Museum of Natural and Cultural History. The National Park Service is not responsible for the determinations in this notice. Additional information on the determinations in this notice, including the results of consultation, can be found in the inventory or related records held by the University of

Oregon Museum of Natural and Cultural History.

Description

Human remains representing, at minimum, nine individuals were removed from Harney County, OR. The human remains were collected by University of Oregon archeologists in July of 1938 at Roaring Springs Cave (35HA33). The fragmentary human remains represent an adult probable male (catalogued as 11-95), an adult probable male (catalogued as 11-96), a 10-15 year-old individual of indeterminate sex (catalogued as 11-97), two 2-4 year-old individuals of indeterminate sex and two adults of indeterminate sex (all catalogued as 11-98), an adult of indeterminate sex (catalogued as 11-99), a 10-25 year-old individual of indeterminate sex (catalogued as 11-100), and human hair catalogued as 1-7104, 1-7815, 1-7856, 1-8108, and 1-8600. No associated funerary objects are present.

Cultural Affiliation

The human remains in this notice are connected to one or more identifiable earlier groups, tribes, peoples, or cultures. There is a relationship of shared group identity between the identifiable earlier groups, tribes, peoples, or cultures and one or more Indian Tribes or Native Hawaiian organizations. The following types of information were used to reasonably trace the relationship: anthropological information, geographical information, historical information.

Determinations

Pursuant to NAGPRA and its implementing regulations, and after consultation with the appropriate Indian Tribes and Native Hawaiian organizations, the University of Oregon Museum of Natural and Cultural History has determined that:

- The human remains described in this notice represent the physical remains of nine individuals of Native American ancestry.
- There is a relationship of shared group identity that can be reasonably traced between the human remains described in this notice and the Burns Paiute Tribe and the Confederated Tribes of the Warm Springs Reservation of Oregon.

Requests for Repatriation

Written requests for repatriation of the human remains in this notice must be sent to the Responsible Official identified in **ADDRESSES**. Requests for repatriation may be submitted by:

1. Any one or more of the Indian Tribes or Native Hawaiian organizations identified in this notice.

2. Any lineal descendant, Indian Tribe, or Native Hawaiian organization not identified in this notice who shows, by a preponderance of the evidence, that the requestor is a lineal descendant or a culturally affiliated Indian Tribe or Native Hawaiian organization.

Repatriation of the human remains in this notice to a requestor may occur on or after April 8, 2024. If competing requests for repatriation are received, the University of Oregon Museum of Natural and Cultural History must determine the most appropriate requestor prior to repatriation. Requests for joint repatriation of the human remains are considered a single request and not competing requests. The University of Oregon Museum of Natural and Cultural History is responsible for sending a copy of this notice to the Indian Tribes and Native Hawaiian organizations identified in this notice.

This notice was submitted before the effective date of the revised regulations (88 FR 86452, December 13, 2023, effective January 12, 2024). As the notice conforms to the mandatory format of the **Federal Register** and includes the required information, the National Park Service is publishing this notice as submitted.

Authority: Native American Graves Protection and Repatriation Act, 25 U.S.C. 3003, and the implementing regulations, 43 CFR 10.10.

Dated: February 29, 2024.

Melanie O'Brien,

Manager, National NAGPRA Program.

[FR Doc. 2024-04987 Filed 3-7-24; 8:45 am]

BILLING CODE 4312-52-P

DEPARTMENT OF THE INTERIOR

National Park Service

[NPS-WASO-NAGPRA-NPS0037563; PPWOCRADN0-PCU00RP14.R50000]

Notice of Intended Repatriation: Field Museum, Chicago, IL

AGENCY: National Park Service, Interior.

ACTION: Notice.

SUMMARY: In accordance with the Native American Graves Protection and Repatriation Act (NAGPRA), the Field Museum intends to repatriate certain cultural items that meet the definition of sacred objects and that have a cultural affiliation with the Indian Tribes or Native Hawaiian organizations in this notice.

DATES: Repatriation of the cultural items in this notice may occur on or after April 8, 2024.

ADDRESSES: Helen Robbins, Repatriation Director, Field Museum, 1400 S Lake Shore Drive, Chicago, IL 60605, telephone (312) 665-7317, email hrobbins@fieldmuseum.org.

SUPPLEMENTARY INFORMATION: This notice is published as part of the National Park Service's administrative responsibilities under NAGPRA. The determinations in this notice are the sole responsibility of the Field Museum and additional information on the determinations in this notice, including the results of consultation, can be found in the summary or related records. The National Park Service is not responsible for the determinations in this notice.

Abstract of Information Available

A total of two cultural items have been requested for repatriation. The two sacred objects are pipes. The pipes were collected by Stewart Culin in 1900 at an "Indian Rancheria on the Mad River" in the Hoopa Valley. At the request of the Wiyot Tribe the cultural items were tested to determine whether they had been treated with contaminants. There is no known presence of any potentially hazardous substances.

Determinations

The Field Museum has determined that:

- The two sacred objects described in this notice are specific ceremonial objects needed by a traditional Native American religious leader for present-day adherents to practice traditional Native American religion, according to the Native American traditional knowledge of a lineal descendant, Indian Tribe, or Native Hawaiian organization.

- The two sacred objects described in this notice are, according to the Native American traditional knowledge of an Indian Tribe or Native Hawaiian organization, specific ceremonial objects needed by a traditional Native American religious leader for present-day adherents to practice traditional Native American religion, and have ongoing historical, traditional, or cultural importance central to the Native American group, including any constituent sub-group (such as a band, clan, lineage, ceremonial society, or other subdivision).

- There is a reasonable connection between the cultural items described in this notice and the Wiyot Tribe, California.

Requests for Repatriation

Additional, written requests for repatriation of the cultural items in this notice must be sent to the authorized representative identified in this notice under **ADDRESSES**. Requests for repatriation may be submitted by any lineal descendant, Indian Tribe, or Native Hawaiian organization not identified in this notice who shows, by a preponderance of the evidence, that the requestor is a lineal descendant or a culturally affiliated Indian Tribe or Native Hawaiian organization.

Repatriation of the cultural items in this notice to a requestor may occur on or after April 8, 2024. If competing requests for repatriation are received, the Field Museum must determine the most appropriate requestor prior to repatriation. Requests for joint repatriation of the cultural items are considered a single request and not competing requests. The Field Museum is responsible for sending a copy of this notice to the Indian Tribes and Native Hawaiian organizations identified in this notice and to any other consulting parties.

Authority: Native American Graves Protection and Repatriation Act, 25 U.S.C. 3004 and the implementing regulations, 43 CFR 10.9.

Dated: February 29, 2024.

Melanie O'Brien,

Manager, National NAGPRA Program.

[FR Doc. 2024-04988 Filed 3-7-24; 8:45 am]

BILLING CODE 4312-52-P

DEPARTMENT OF THE INTERIOR

National Park Service

[NPS-WASO-NAGPRA-NPS0037555;
PPWOCRADNO-PCU00RP14.R50000]

Notice of Inventory Completion: Longyear Museum of Anthropology, Colgate University, Hamilton, NY

AGENCY: National Park Service, Interior.

ACTION: Notice.

SUMMARY: In accordance with the Native American Graves Protection and Repatriation Act (NAGPRA), the Longyear Museum of Anthropology (LMA), Colgate University, has completed an inventory of human remains and has determined that there is a cultural affiliation between the human remains and Indian Tribes or Native Hawaiian organizations in this notice.

DATES: Repatriation of the human remains in this notice may occur on or after April 8, 2024.

ADDRESSES: Kelsey Olney-Wall, Repatriation Manager, Longyear Museum of Anthropology, Colgate University, 13 Oak Drive, Hamilton, NY 13346, telephone (315) 228-7677, email kolneywall@colgate.edu.

SUPPLEMENTARY INFORMATION: This notice is published as part of the National Park Service's administrative responsibilities under NAGPRA. The determinations in this notice are the sole responsibility of the LMA. The National Park Service is not responsible for the determinations in this notice. Additional information on the determinations in this notice, including the results of consultation, can be found in the inventory or related records held by the LMA.

Description

The preponderance of evidence suggests that human remains representing, at minimum, seven individuals were removed from Madison County, NY, sometime between 1960-1969. The human remains were removed from an unknown site by avocational archeologist Theodore Whitney. Mr. Whitney donated the human remains in the early 1970s to the Longyear Museum of Anthropology. No associated funerary belongings are present.

It was previously reported in a Notice of Inventory Completion (68 FR 67209, December 1, 2003) that Mr. Whitney donated the human remains in 1980, however, the LMA staff determined these human remains were a part of the donation from the early 1970s, with a reference in an Annual report from the Sociology and Anthropology Department at Colgate University. At minimum, one individual with similar catalog numbers was identified as being removed from the Thurston Site by Theodore Whitney and subsequently repatriated to the Oneida Indian Nation in 1995. The LMA established the seven individuals are connected to the human remains that were repatriated to Oneida Indian Nation in 1995.

Cultural affiliation

The human remains in this notice are connected to one or more identifiable earlier groups, tribes, peoples, or cultures. There is a relationship of shared group identity between the identifiable earlier groups, tribes, peoples, or cultures and one or more Indian Tribes or Native Hawaiian organizations. The following types of information were used to reasonably trace the relationship: anthropological information, geographical information, historical information, and expert opinion.

Determinations

Pursuant to NAGPRA and its implementing regulations, and after consultation with the appropriate Indian Tribes and Native Hawaiian organizations, the LMA has determined that:

- The human remains described in this notice represent the physical remains of seven individuals of Native American ancestry.
- There is a relationship of shared group identity that can be reasonably traced between the human remains described in this notice and the Oneida Indian Nation.

Requests for Repatriation

Written requests for repatriation of the human remains in this notice must be sent to the authorized representative identified in this notice under **ADDRESSES**. Requests for repatriation may be submitted by:

1. Any one or more of the Indian Tribes or Native Hawaiian organizations identified in this notice.
2. Any lineal descendant, Indian Tribe, or Native Hawaiian organization not identified in this notice who shows, by a preponderance of the evidence, that the requestor is a lineal descendant or a culturally affiliated Indian Tribe or Native Hawaiian organization.

Repatriation of the human remains in this notice to a requestor may occur on or after April 8, 2024. If competing requests for repatriation are received, the LMA must determine the most appropriate requestor prior to repatriation. Requests for joint repatriation of the human remains are considered a single request and not competing requests. The LMA is responsible for sending a copy of this notice to the Indian Tribes and Native Hawaiian organizations identified in this notice.

This notice was submitted before the effective date of the revised regulations (88 FR 86452, December 13, 2023, effective January 12, 2024). As the notice conforms to the mandatory format of the **Federal Register** and includes the required information, the National Park Service is publishing this notice as submitted.

Authority: Native American Graves Protection and Repatriation Act, 25 U.S.C. 3003, and the implementing regulations, 43 CFR 10.10.

Dated: February 29, 2024.

Melanie O'Brien,

Manager, National NAGPRA Program.

[FR Doc. 2024-04981 Filed 3-7-24; 8:45 am]

BILLING CODE 4312-52-P

DEPARTMENT OF THE INTERIOR**National Park Service**

[NPS–WASO–NAGPRA–NPS0037567; PPWOCRADN0–PCU00RP14.R50000]

Notice of Inventory Completion: California State Department of Transportation, Sacramento, CA**AGENCY:** National Park Service, Interior.**ACTION:** Notice.

SUMMARY: In accordance with the Native American Graves Protection and Repatriation Act (NAGPRA), the California State Department of Transportation (Caltrans) has completed an inventory of associated funerary objects and have determined that there is a cultural affiliation between the associated funerary objects and Indian Tribes in this notice. The associated funerary objects were removed from Sacramento County, CA.

DATES: Repatriation of the associated funerary objects in this notice may occur on or after April 8, 2024.

ADDRESSES: Dr. Lisa Bright, Branch Chief District 3, Cultural Resources (South), California State Department of Transportation, 703 B Street Marysville, CA 95901, telephone (530) 812–4569, email Lisa.Bright@dot.ca.gov.

SUPPLEMENTARY INFORMATION: This notice is published as part of the National Park Service's administrative responsibilities under NAGPRA. The determinations in this notice are the sole responsibility of Caltrans. The National Park Service is not responsible for the determinations in this notice. Additional information on the determinations in this notice, including the results of consultation, can be found in the inventory or related records held by the California Department of Transportation.

Description

An archaeological investigation of CA–SAC–133, and collection and analysis of cultural materials was performed by Far Western Anthropological Research Group Inc. (Far Western) under contract with Caltrans in December of 1991. The studies were reported on in a Historic Property Survey Report (HPSR) prepared by Daryl Noble (Caltrans) dated June 1991 and, at the conclusion of Far Western's analytical studies, in a June 1992. Mr. William ("Bill") J. Franklin, Sr. (Miwok) was on site during archaeological testing. An extremely robust and wide ranging collection of material was retrieved from the site. The seven burials were found in the units

excavated in the southernmost site area. These ancestors were left in situ, or reburied before the completion of the field work. The materials have been curated at University of California, Davis.

Cultural Affiliation

The associated funerary objects in this notice are connected to one or more identifiable earlier groups, tribes, peoples, or cultures. There is a relationship of shared group identity between the identifiable earlier groups, tribes, peoples, or cultures and one or more Indian Tribes or Native Hawaiian organizations. The following types of information were used to reasonably trace the relationship: anthropological, archeological, geographical, historical, oral traditional, and expert opinion.

Determinations

Pursuant to NAGPRA and its implementing regulations, and after consultation with the appropriate Indian Tribes and Native Hawaiian organizations, Caltrans has determined that:

- The 1,444 catalog entries described in this notice are reasonably believed to have been placed with or near individual human remains at the time of death or later as part of the death rite or ceremony.
- There is a relationship of shared group identity that can be reasonably traced between the human remains and associated funerary objects described in this notice and the Buena Vista Rancheria of Me-Wuk Indians of California; Chicken Ranch Rancheria of Me-Wuk Indians of California; Ione Band of Miwok Indians of California; Jackson Band of Miwok Indians; Shingle Springs Band of Miwok Indians, Shingle Springs Rancheria (Verona Tract), California; United Auburn Indian Community of the Auburn Rancheria of California; and the Wilton Rancheria, California.

Requests for Repatriation

Written requests for repatriation of the associated funerary objects in this notice must be sent to the Responsible Official identified in **ADDRESSES**. Requests for repatriation may be submitted by:

1. Any one or more of the Indian Tribes or Native Hawaiian organizations identified in this notice.
2. Any lineal descendant, Indian Tribe, or Native Hawaiian organization not identified in this notice who shows, by a preponderance of the evidence, that the requestor is a lineal descendant or a culturally affiliated Indian Tribe or Native Hawaiian organization.

Repatriation of the associated funerary objects in this notice to a requestor may occur on or after April 8, 2024. If competing requests for repatriation are received, California State University, Sacramento must determine the most appropriate requestor prior to repatriation. Requests for joint repatriation of the associated funerary objects are considered a single request and not competing requests. Caltrans is responsible for sending a copy of this notice to the Indian Tribes identified in this notice.

This notice was submitted after the effective date of the revised regulations (88 FR 86452, December 13, 2023, effective January 12, 2024) but in the older format. As the notice conforms to the mandatory format of the **Federal Register** and includes the required information, the National Park Service is publishing this notice as submitted.

Authority: Native American Graves Protection and Repatriation Act, 25 U.S.C. 3003, and the implementing regulations, 43 CFR 10.10.

Dated: February 29, 2024.

Melanie O'Brien,

Manager, National NAGPRA Program.

[FR Doc. 2024–04990 Filed 3–7–24; 8:45 am]

BILLING CODE 4312–52–P

DEPARTMENT OF THE INTERIOR**National Park Service**

[NPS–WASO–NAGPRA–NPS0037569; PPWOCRADN0–PCU00RP14.R50000]

Notice of Inventory Completion: California State University, Sacramento, Sacramento, CA and East Bay Municipal Utility District, Oakland, CA**AGENCY:** National Park Service, Interior.**ACTION:** Notice.

SUMMARY: In accordance with the Native American Graves Protection and Repatriation Act (NAGPRA), the California State University, Sacramento and East Bay Municipal Utility District (EBMUD) have completed an inventory of human remains and associated funerary objects and has determined that there is a cultural affiliation between the human remains and associated funerary objects and Indian Tribes or Native Hawaiian organizations in this notice.

DATES: Repatriation of the human remains and associated funerary objects in this notice may occur on or after April 8, 2024.

ADDRESSES: Dr. Mark Wheeler, Chief of Staff to President Luke Wood, California

State University, Sacramento, 6000 J Street, Sacramento, CA 95819, telephone (916) 460-0490, email mark.wheeler@csus.edu and Chuck Beckman, Manager of Watershed and Recreation, East Bay Municipal Utility District, 15083 Camanche Parkway South, Valley Springs, CA 95252, telephone (209) 772-8203, email 1847charles.beckman@ebmud.com.

SUPPLEMENTARY INFORMATION: This notice is published as part of the National Park Service's administrative responsibilities under NAGPRA. The determinations in this notice are the sole responsibility of California State University, Sacramento and EBMUD, and additional information on the determinations in this notice, including the results of consultation, can be found in the inventory or related records. The National Park Service is not responsible for the determinations in this notice.

Abstract of Information Available

In 1959 and 1960s, human remains representing, at minimum, three individuals were removed from CA-AMA-03 (also known as Bamert Cave), by students of Sacramento State College (now California State University, Sacramento) under the direction of William Beeson. The collections have been housed at California State University, Sacramento since this excavation. Occupation of the site is estimated to have occurred during the Late Prehistoric into Historic periods. No known individuals were identified. The 6,457 associated funerary objects removed from this site includes flaked stone, groundstone, modified bone, modified wood, modified stone, modified shell, textiles, floral remains, basketry fragments, faunal remains, historic materials, pigment, unmodified stone, geologic samples, and soil samples. Of this number, 11 objects are currently missing from the collection. California State University, Sacramento continues to look for these 11 missing objects.

In 1963, human remains representing, at minimum, seven individuals were removed from CA-AMA-23 (also known as China Gulch) by a Sacramento State College (now California State University, Sacramento) field class under the direction of Patti Palumbo and William Beeson. The collection has been housed at California State University, Sacramento since this excavation. Occupation of the site is estimated to have occurred during the Late Prehistoric into Historic periods, though there is some evidence of an earlier occupation. No known individuals were identified. The 11,932

associated funerary objects removed from this site includes flaked stone, groundstone, thermally-altered rock, modified bone, modified stone, modified shell, floral remains, faunal remains, historic materials, pigment, unmodified stone, geologic samples, and soil samples.

In 1963, human remains representing, at minimum, two individuals were removed from CA-AMA-49 (also known as Big Cave and China Gulch Cave) by Sacramento State College (now California State University, Sacramento) students under the direction of Jerald J. Johnson. The collection has been housed at California State University, Sacramento since this excavation. Occupation of the site is estimated to have occurred during the Late Prehistoric into Historic periods, though there is some evidence of an earlier occupation. No known individuals were identified. The 2,087 associated funerary objects removed from this site includes flaked stone, modified bone, modified stone, modified shell, floral remains, faunal remains, historic materials, unmodified stone, and coprolites.

In 1960, human remains representing, at minimum, one individual were removed from CA-AMA-70 (also known as the Goins site) by a Sacramento State College (now California State University, Sacramento) field class under the direction of William Beeson. The collection has been housed at California State University, Sacramento since this excavation. Occupation of the site is not known, though there is clear evidence of use during the Historic period. No known individuals were identified. The 376 associated funerary objects removed from this site includes flaked stone, groundstone, modified shell, floral remains, faunal remains, historic materials, unmodified stone, pigment, thermally-altered rock, geologic samples, and soil samples. Of this number, 24 objects are currently missing from the collection. California State University, Sacramento continues to look for these 24 missing objects.

In 1963, human remains representing, at minimum, 18 individuals were removed from CA-AMA-91 (also known as the Dier site) by a Sacramento State College (now California State University, Sacramento) field class with other students from American River College and community volunteers under contract with EBMUD. The collection has been housed at California State University, Sacramento since this excavation. Occupation of the site is estimated to have occurred during the Late Prehistoric into Historic periods,

though there is some evidence of an earlier occupation. No known individuals were identified. The 5,511 associated funerary objects removed from this site include baked clay, flaked stone, groundstone, modified bone, modified stone, modified shell, floral remains, faunal remains, historic materials, pigment, unmodified stone, clay insect nest, and soil samples.

Cultural Affiliation

Based on the information available and the results of consultation, cultural affiliation is clearly identified by the information available about the human remains and associated funerary objects described in this notice.

Determinations

California State University, Sacramento and EBMUD have determined that:

- The human remains described in this notice represent the physical remains of 31 individuals of Native American ancestry.
- The 26,363 objects described in this notice are reasonably believed to have been placed with or near individual human remains at the time of death or later as part of the death rite or ceremony.
- There is a reasonable connection between the human remains and associated funerary objects described in this notice and the Buena Vista Rancheria of Me-Wuk Indians of California; California Valley Miwok Tribe, California; Chicken Ranch Rancheria of Me-Wuk Indians of California; Ione Band of Miwok Indians of California; Jackson Band of Miwok Indians; Shingle Springs Band of Miwok Indians, Shingle Springs Rancheria (Verona Tract), California; United Auburn Indian Community of the Auburn Rancheria of California; and the Wilton Rancheria, California.

Requests for Repatriation

Written requests for repatriation of the human remains and associated funerary objects in this notice must be sent to the authorized representative identified in this notice under **ADDRESSES**. Requests for repatriation may be submitted by:

1. Any one or more of the Indian Tribes or Native Hawaiian organizations identified in this notice.
2. Any lineal descendant, Indian Tribe, or Native Hawaiian organization not identified in this notice who shows, by a preponderance of the evidence, that the requestor is a lineal descendant or a culturally affiliated Indian Tribe or Native Hawaiian organization.

Repatriation of the human remains and associated funerary objects in this

notice to a requestor may occur on or after April 8, 2024. If competing requests for repatriation are received, California State University, Sacramento and EBMUD must determine the most appropriate requestor prior to repatriation. Requests for joint repatriation of the human remains and associated funerary objects are considered a single request and not competing requests. California State University, Sacramento and EBMUD are responsible for sending a copy of this notice to the Indian Tribes identified in this notice.

Authority: Native American Graves Protection and Repatriation Act, 25 U.S.C. 3003, and the implementing regulations, 43 CFR 10.10.

Dated: February 29, 2024.

Melanie O'Brien,

Manager, National NAGPRA Program.

[FR Doc. 2024-04992 Filed 3-7-24; 8:45 am]

BILLING CODE 4312-52-P

DEPARTMENT OF THE INTERIOR

National Park Service

[NPS-WASO-NAGPRA-NPS0037560;
PPWOCRADNO-PCU00RP14.R50000]

Notice of Inventory Completion: University of Oregon Museum of Natural and Cultural History, Eugene, OR

AGENCY: National Park Service, Interior.

ACTION: Notice.

SUMMARY: In accordance with the Native American Graves Protection and Repatriation Act (NAGPRA), the University of Oregon Museum of Natural and Cultural History has completed an inventory of human remains and has determined that there is a cultural affiliation between the human remains and Indian Tribes or Native Hawaiian organizations in this notice. The human remains were removed from the state of Oregon.

DATES: Repatriation of the human remains in this notice may occur on or after April 8, 2024.

ADDRESSES: Dr. Pamela Endzweig, Director of Anthropological Collections, University of Oregon Museum of Natural and Cultural History, 1224 University of Oregon, Eugene, OR 97403-1224, telephone (541) 346-5120, email endzweig@uoregon.edu.

SUPPLEMENTARY INFORMATION: This notice is published as part of the National Park Service's administrative responsibilities under NAGPRA. The determinations in this notice are the sole responsibility of the University of

Oregon Museum of Natural and Cultural History. The National Park Service is not responsible for the determinations in this notice. Additional information on the determinations in this notice, including the results of consultation, can be found in the inventory or related records held by the University of Oregon Museum of Natural and Cultural History.

Description

Human remains representing, at minimum, one individual, were removed from an unknown location, by an unknown collector at an unknown date. Based on the Museum's statutory role as Oregon's State Anthropological Repository, the fragmentary human remains (cat. # Unknown-3) were likely removed from the state of Oregon. The human remains are from an individual of indeterminate age and sex. No associated funerary objects are present.

Human remains representing, at minimum, one individual, were removed from an unknown location, by an unknown collector at an unknown date. Based on the Museum's statutory role as Oregon's State Anthropological Repository, the fragmentary human remains (cat. # Unknown-8) were likely removed from the state of Oregon. The human remains are from a probable male, adult individual. No associated funerary objects are present.

Human remains representing, at minimum, one individual, were removed from an unknown location, by an unknown collector at an unknown date. Based on the Museum's statutory role as Oregon's State Anthropological Repository, the fragmentary human remains (cat. # Unknown-14) were likely removed from the state of Oregon. The human remains are from an adult male individual. No associated funerary objects are present.

Human remains representing, at minimum, one individual, were removed from an unknown location, by an unknown collector at an unknown date. Based on the Museum's statutory role as Oregon's State Anthropological Repository, the fragmentary human remains (cat. # Unknown-15) were likely removed from the state of Oregon. The human remains are from a female individual between 45-60 years of age. No associated funerary objects are present.

Human remains representing, at minimum, one individual, were removed from an unknown location, by an unknown collector at an unknown date. Based on the Museum's statutory role as Oregon's State Anthropological Repository, the fragmentary human remains (cat. # Unknown-16) were

likely removed from the state of Oregon. The human remains are from an adult individual of indeterminate sex. No associated funerary objects are present.

Human remains representing, at minimum, one individual, were removed from an unknown location, by an unknown collector at an unknown date. Based on the Museum's statutory role as Oregon's State Anthropological Repository, the fragmentary human remains (cat. # Unknown-18) were likely removed from the state of Oregon. The human remains are from a female individual between 30-50 years of age. No associated funerary objects are present.

Human remains representing, at minimum, one individual, were removed from an unknown location, by an unknown collector at an unknown date. Based on the Museum's statutory role as Oregon's State Anthropological Repository, the fragmentary human remains (cat. # Unknown-19) were likely removed from the state of Oregon. The human remains are from an individual of indeterminate sex, between 6-8 years of age. No associated funerary objects are present.

Human remains representing, at minimum, two individuals, were removed from an unknown location, by an unknown collector at an unknown date. Based on the Museum's statutory role as Oregon's State Anthropological Repository, the fragmentary human remains (cat. # Unknown-20) were likely removed from the state of Oregon. The human remains are from an individual of indeterminate sex between 4-8 years of age and an adult individual of indeterminate sex. No associated funerary objects are present.

Human remains representing, at minimum, two individuals, were removed from an unknown location, by an unknown collector at an unknown date. Based on the Museum's statutory role as Oregon's State Anthropological Repository, the fragmentary human remains (cat. # 11-45; field no. SK8) were likely removed from the state of Oregon. They appear in the Museum's catalog between 1932 and 1936. The human remains are from an individual of indeterminate sex between 15-19 years of age and an adult probable male individual. No associated funerary objects are present.

Human remains representing, at minimum, one individual, were removed from an unknown location, by an unknown collector at an unknown date. Based on the Museum's statutory role as Oregon's State Anthropological Repository, the fragmentary human remains (cat. # 11-46) were likely removed from the state of Oregon. They

appear in the Museum's catalog between 1932 and 1936. The human remains are from an adult female individual. No associated funerary objects are present.

Human remains representing, at minimum, two individuals, were removed from an unknown location, by an unknown collector at an unknown date. Based on the Museum's statutory role as Oregon's State Anthropological Repository, the fragmentary human remains (cat. # 11-47) were likely removed from the state of Oregon. They appear in the Museum's catalog between 1932 and 1936. The human remains are from an adult female individual and an individual of indeterminate sex between 3-4 years of age. No associated funerary objects are present.

Human remains representing, at minimum, two individuals, were removed from an unknown location, by an unknown collector at an unknown date. Based on the Museum's statutory role as Oregon's State Anthropological Repository, the fragmentary human remains (cat. # 11-137) were likely removed from the state of Oregon. They appear in the Museum's catalog between 1940 and 1942. The human remains are from an individual of indeterminate sex between 10-14 years of age, and an adult individual of indeterminate sex. No associated funerary objects are present.

Human remains representing, at minimum, one individual, were removed from an unknown location, by an unknown collector at an unknown date. Based on the Museum's statutory role as Oregon's State Anthropological Repository, the fragmentary human remains (cat. # 11-201b) were likely removed from the state of Oregon. Their appearance in the Museum's catalog dates to ca.1947. The human remains are from a female individual between 21-30 years of age. No associated funerary objects are present.

Human remains representing, at minimum, one individual, were removed from an unknown location, by an unknown collector at an unknown date. Based on the Museum's statutory role as Oregon's State Anthropological Repository, the fragmentary human remains (cat. # 11-264) were likely removed from the state of Oregon. At an unknown date, the human remains became part of a "biology department's vertebrate collection," presumably the University of Oregon. The human remains were accessioned by the Museum under #100LL in May 1951. The human remains are from an adult individual of indeterminate sex. No associated funerary objects are present.

Human remains representing, at minimum, one individual, were

removed from an unknown location, by an unknown collector at an unknown date. Based on the Museum's statutory role as Oregon's State Anthropological Repository, the fragmentary human remains (cat. # 11-276) were likely removed from the state of Oregon. The human remains were received by the Museum from the Portland Crime Detection Laboratory and accessioned under accession number 100MH in April of 1952. The human remains are from a female individual between 30-35 years of age. No associated funerary objects are present.

Human remains representing, at minimum, one individual, were removed from an unknown location, by an unknown collector at an unknown date. Based on the Museum's statutory role as Oregon's State Anthropological Repository, the fragmentary human remains (cat. # 11-290) were likely removed from the state of Oregon. The human remains were donated to the Museum by Dr. Homer Harris of the University of Oregon Medical School Crime Detection Laboratory, possibly in the 1950's. The human remains are from a female individual between 20-25 years of age. No associated funerary objects are present.

Human remains representing, at minimum, one individual, were removed from an unknown location, by an unknown collector at an unknown date. Based on the Museum's statutory role as Oregon's State Anthropological Repository, the fragmentary human remains (cat. # 11-316) were likely removed from the state of Oregon. The human remains are from a female individual between 25-35 years of age. No associated funerary objects are present.

Human remains representing, at minimum, one individual, were removed from an unknown location, by an unknown collector at an unknown date. Based on the Museum's statutory role as Oregon's State Anthropological Repository, the fragmentary human remains (cat. # 11-410) were likely removed from the state of Oregon. The human remains were obtained by the Museum in 1955 from the University of Oregon biology department. The human remains are from a female individual between 25-35 years of age. No associated funerary objects are present.

Human remains representing, at minimum, two individuals, were removed from an unknown location, by an unknown collector at an unknown date. Based on the Museum's statutory role as Oregon's State Anthropological Repository, the fragmentary human remains (cat. # 11-411) were likely removed from the state of Oregon. The

human remains were obtained by the Museum in 1955 from the University of Oregon biology department. The human remains are from a male individual between 40-45 years of age, and a subadult individual of indeterminate sex. No associated funerary objects are present.

Human remains representing, at minimum, one individual, were removed from an unknown location, by an unknown collector at an unknown date. Based on the Museum's statutory role as Oregon's State Anthropological Repository, the fragmentary human remains (cat. # 11-487) were likely removed from the state of Oregon. The human remains are from a male individual between 18-24 years of age. No associated funerary objects are present.

Human remains representing, at minimum, three individuals, were removed from an unknown location, by an unknown collector at an unknown date. Based on the Museum's statutory role as Oregon's State Anthropological Repository, the fragmentary human remains (cat. # 11-492) were likely removed from the state of Oregon. The human remains are from a female individual between 35-55 years of age, a male individual between 45-50 years of age, and a possibly male adult individual. No associated funerary objects are present.

Human remains representing, at minimum, one individual, were removed from an unknown location, by an unknown collector at an unknown date. Based on the Museum's statutory role as Oregon's State Anthropological Repository, the fragmentary human remains (cat. # 11-524) were likely removed from the state of Oregon. The human remains are from an adult individual of more than 25 years of age. No associated funerary objects are present.

Human remains representing, at minimum, three individuals, were removed from an unknown location, by an unknown collector at an unknown date, possibly by Joel Shiner and William S. Laughlin, in the 1940s-1950s. Based on the Museum's statutory role as Oregon's State Anthropological Repository, the fragmentary human remains (cat. # 11-553) were likely removed from the state of Oregon. The human remains are from an individual of indeterminate sex between one-to-four years of age, an individual of indeterminate sex between fetal and nine months of age, and an adult individual of indeterminate sex. No associated funerary objects are present.

Human remains representing, at minimum, one individual, were

removed from an unknown location, by an unknown collector at an unknown date. Based on the Museum's statutory role as Oregon's State Anthropological Repository, the fragmentary human remains (cat. # 11-554) were likely removed from the state of Oregon. The human remains are from a possibly female individual between 20-40 years of age. No associated funerary objects are present.

Human remains representing, at minimum, two individuals, were removed from an unknown location, by an unknown collector at an unknown date. Based on the Museum's statutory role as Oregon's State Anthropological Repository, the fragmentary human remains (no cat. #) were likely removed from the state of Oregon. Human remains associated in storage (cat. #s 11-550, 11-551, 11-552, and 11-553) were removed from Astoria, OR; Bandon, OR; and an unknown location. The human remains are from an individual of indeterminate sex between 10-15 years of age and an adult individual of indeterminate sex. No associated funerary objects are present.

Cultural Affiliation

The human remains in this notice are connected to one or more identifiable earlier groups, tribes, peoples, or cultures. There is a relationship of shared group identity between the identifiable earlier groups, tribes, peoples, or cultures and one or more Indian Tribes or Native Hawaiian organizations. The following types of information were used to reasonably trace the relationship: geographical information.

Determinations

Pursuant to NAGPRA and its implementing regulations, and after consultation with the appropriate Indian Tribes and Native Hawaiian organizations, the University of Oregon Museum of Natural and Cultural History has determined that:

- The human remains described in this notice represent the physical remains of 35 individuals of Native American ancestry.
- There is a relationship of shared group identity that can be reasonably traced between the human remains described in this notice and the Burns Paiute Tribe; Confederated Tribes of Siletz Indians of Oregon; Confederated Tribes of the Coos, Lower Umpqua and Siuslaw Indians; Confederated Tribes of the Grand Ronde Community of Oregon; Confederated Tribes of the Umatilla Indian Reservation; Confederated Tribes of the Warm Springs Reservation of Oregon; Coquille Indian Tribe; Cow

Creek Band of Umpqua Tribe of Indians; and the Klamath Tribes.

Requests for Repatriation

Written requests for repatriation of the human remains in this notice must be sent to the Responsible Official identified in **ADDRESSES**. Requests for repatriation may be submitted by:

1. Any one or more of the Indian Tribes or Native Hawaiian organizations identified in this notice.
2. Any lineal descendant, Indian Tribe, or Native Hawaiian organization not identified in this notice who shows, by a preponderance of the evidence, that the requestor is a lineal descendant or a culturally affiliated Indian Tribe or Native Hawaiian organization.

Repatriation of the human remains in this notice to a requestor may occur on or after April 8, 2024. If competing requests for repatriation are received, the University of Oregon Museum of Natural and Cultural History must determine the most appropriate requestor prior to repatriation. Requests for joint repatriation of the human remains are considered a single request and not competing requests. The University of Oregon Museum of Natural and Cultural History is responsible for sending a copy of this notice to the Indian Tribes and Native Hawaiian organizations identified in this notice.

This notice was submitted before the effective date of the revised regulations (88 FR 86452, December 13, 2023, effective January 12, 2024). As the notice conforms to the mandatory format of the **Federal Register** and includes the required information, the National Park Service is publishing this notice as submitted.

Authority: Native American Graves Protection and Repatriation Act, 25 U.S.C. 3003, and the implementing regulations, 43 CFR 10.10.

Dated: February 29, 2024.

Melanie O'Brien,

Manager, National NAGPRA Program.

[FR Doc. 2024-04986 Filed 3-7-24; 8:45 am]

BILLING CODE 4312-52-P

DEPARTMENT OF THE INTERIOR

National Park Service

[NPS-WASO-NAGPRA-NPS0037558; PPWOCRADNO-PCU00RP14.R50000]

Notice of Inventory Completion: University of Oregon Museum of Natural and Cultural History, Eugene, OR

AGENCY: National Park Service, Interior.

ACTION: Notice.

SUMMARY: In accordance with the Native American Graves Protection and Repatriation Act (NAGPRA), the University of Oregon Museum of Natural and Cultural History has completed an inventory of human remains and has determined that there is a cultural affiliation between the human remains and Indian Tribes or Native Hawaiian organizations in this notice. The human remains were removed from Kodiak Island Borough, AK.

DATES: Repatriation of the human remains in this notice may occur on or after April 8, 2024.

ADDRESSES: Dr. Pamela Endzweig, Director of Anthropological Collections, University of Oregon Museum of Natural and Cultural History, 1224 University of Oregon, Eugene, OR 97403-1224, telephone (541) 346-5120, email endzweig@uoregon.edu.

SUPPLEMENTARY INFORMATION: This notice is published as part of the National Park Service's administrative responsibilities under NAGPRA. The determinations in this notice are the sole responsibility of the University of Oregon Museum of Natural and Cultural History. The National Park Service is not responsible for the determinations in this notice. Additional information on the determinations in this notice, including the results of consultation, can be found in the inventory or related records held by the University of Oregon Museum of Natural and Cultural History.

Description

In 1964, human remains representing, at minimum, one individual, were removed from Kodiak Island Borough, AK. The fragmentary human remains were located among non-human faunal materials collected by a former University of Oregon archeologist from the Our Point site on Larsen Bay, Alaska. The human remains are from an infant of indeterminate sex. No associated funerary objects are present.

Cultural Affiliation

The human remains in this notice are connected to one or more identifiable earlier groups, tribes, peoples, or cultures. There is a relationship of shared group identity between the identifiable earlier groups, tribes, peoples, or cultures and one or more Indian Tribes or Native Hawaiian organizations. The following types of information were used to reasonably trace the relationship: anthropological information, geographical information.

Determinations

Pursuant to NAGPRA and its implementing regulations, and after consultation with the appropriate Indian Tribes and Native Hawaiian organizations, the University of Oregon Museum of Natural and Cultural History:

- The human remains described in this notice represent the physical remains of one individual of Native American ancestry.
- There is a relationship of shared group identity that can be reasonably traced between the human remains described in this notice and the Native Village of Larsen Bay.

Requests for Repatriation

Written requests for repatriation of the human remains in this notice must be sent to the Responsible Official identified in **ADDRESSES**. Requests for repatriation may be submitted by:

1. Any one or more of the Indian Tribes or Native Hawaiian organizations identified in this notice.
2. Any lineal descendant, Indian Tribe, or Native Hawaiian organization not identified in this notice who shows, by a preponderance of the evidence, that the requestor is a lineal descendant or a culturally affiliated Indian Tribe or Native Hawaiian organization.

Repatriation of the human remains in this notice to a requestor may occur on or after April 8, 2024. If competing requests for repatriation are received, the University of Oregon Museum of Natural and Cultural History must determine the most appropriate requestor prior to repatriation. Requests for joint repatriation of the human remains are considered a single request and not competing requests. The University of Oregon Museum of Natural and Cultural History is responsible for sending a copy of this notice to the Indian Tribes and Native Hawaiian organizations identified in this notice.

This notice was submitted before the effective date of the revised regulations (88 FR 86452, December 13, 2023, effective January 12, 2024). As the notice conforms to the mandatory format of the **Federal Register** and includes the required information, the National Park Service is publishing this notice as submitted.

Authority: Native American Graves Protection and Repatriation Act, 25 U.S.C. 3003, and the implementing regulations, 43 CFR 10.10.

Dated: February 29, 2024.

Melanie O'Brien,

Manager, National NAGPRA Program.

[FR Doc. 2024-04984 Filed 3-7-24; 8:45 am]

BILLING CODE 4312-52-P

DEPARTMENT OF THE INTERIOR

National Park Service

[NPS-WASO-NAGPRA-NPS0037556; PPWOCRADNO-PCU00RP14.R50000]

Notice of Inventory Completion: University of Oregon Museum of Natural and Cultural History, Eugene, OR

AGENCY: National Park Service, Interior.

ACTION: Notice.

SUMMARY: In accordance with the Native American Graves Protection and Repatriation Act (NAGPRA), the University of Oregon Museum of Natural and Cultural History has completed an inventory of human remains and has determined that there is a cultural affiliation between the human remains and Indian Tribes or Native Hawaiian organizations in this notice. The human remains were removed from Lake County, OR.

DATES: Repatriation of the human remains in this notice may occur on or after April 8, 2024.

ADDRESSES: Dr. Pamela Endzweig, Director of Anthropological Collections, University of Oregon Museum of Natural and Cultural History, 1224 University of Oregon, Eugene, OR 97403-1224, telephone (541) 346-5120, email endzweig@uoregon.edu.

SUPPLEMENTARY INFORMATION: This notice is published as part of the National Park Service's administrative responsibilities under NAGPRA. The determinations in this notice are the sole responsibility of the University of Oregon Museum of Natural and Cultural History. The National Park Service is not responsible for the determinations in this notice. Additional information on the determinations in this notice, including the results of consultation, can be found in the inventory or related records held by the University of Oregon Museum of Natural and Cultural History.

Description

In 1972, fragmentary human remains representing, at minimum, one individual, were removed from Lake County, OR. According to documentation accompanying the human remains, they were collected by a University of Oregon archeologist on

September 23, 1972, at a location in "the Windust area of large camp, south shore Christmas Lake." A handwritten site form by the collector referencing the same date indicates that this site is possibly 35LK1355, also known as the AWOL site. The archeologist worked at the University of Oregon Museum of Natural History (former designation) around this time and likely deposited the remains for safe-keeping. The age and sex of the human remains are indeterminate. No associated funerary objects are present.

Human remains representing, at minimum, one individual, were removed from Lake County, OR. At an unknown date, human remains were collected by an unknown collector from Christmas Valley, Lake County, Oregon. The human remains (catalogued as 11-517) are from an adult female, 50-60 years of age. No associated funerary objects are present.

In 1966, human remains representing, at minimum, one individual, were removed from Lake County, OR. Humans remains were collected from Fort Rock Cave (35LK1), Lake County, OR, during legally authorized excavations by University of Oregon archeologists. The fragmentary human remains were located during recent analysis of faunal materials from the site. There is no reference to them in archived field records or catalog for this unit (Square 4) and 1966 work at the site was in highly disturbed deposits. The age and sex of the human remains are indeterminate. No associated funerary objects are present.

Cultural Affiliation

The human remains in this notice are connected to one or more identifiable earlier groups, tribes, peoples, or cultures. There is a relationship of shared group identity between the identifiable earlier groups, tribes, peoples, or cultures and one or more Indian Tribes or Native Hawaiian organizations. The following types of information were used to reasonably trace the relationship: anthropological information, geographical information.

Determinations

Pursuant to NAGPRA and its implementing regulations, and after consultation with the appropriate Indian Tribes and Native Hawaiian organizations, the University of Oregon Museum of Natural and Cultural History has determined that:

- The human remains described in this notice represent the physical remains of three individuals of Native American ancestry.

- There is a relationship of shared group identity that can be reasonably traced between the human remains described in this notice and the Burns Paiute Tribe; Confederated Tribes of the Warm Springs Reservation of Oregon; and the Klamath Tribes.

Requests for Repatriation

Written requests for repatriation of the human remains in this notice must be sent to the Responsible Official identified in **ADDRESSES**. Requests for repatriation may be submitted by:

1. Any one or more of the Indian Tribes or Native Hawaiian organizations identified in this notice.
2. Any lineal descendant, Indian Tribe, or Native Hawaiian organization not identified in this notice who shows, by a preponderance of the evidence, that the requestor is a lineal descendant or a culturally affiliated Indian Tribe or Native Hawaiian organization.

Repatriation of the human remains in this notice to a requestor may occur on or after April 8, 2024. If competing requests for repatriation are received, the University of Oregon Museum of Natural and Cultural History must determine the most appropriate requestor prior to repatriation. Requests for joint repatriation of the human remains are considered a single request and not competing requests. The University of Oregon Museum of Natural and Cultural History is responsible for sending a copy of this notice to the Indian Tribes and Native Hawaiian organizations identified in this notice.

This notice was submitted before the effective date of the revised regulations (88 FR 86452, December 13, 2023, effective January 12, 2024). As the notice conforms to the mandatory format of the **Federal Register** and includes the required information, the National Park Service is publishing this notice as submitted.

Authority: Native American Graves Protection and Repatriation Act, 25 U.S.C. 3003, and the implementing regulations, 43 CFR 10.10.

Dated: February 29, 2024.

Melanie O'Brien,

Manager, National NAGPRA Program.

[FR Doc. 2024-04982 Filed 3-7-24; 8:45 am]

BILLING CODE 4312-52-P

DEPARTMENT OF THE INTERIOR

National Park Service

[NPS-WASO-NAGPRA-NPS0037557; PPWOCRADNO-PCU00RP14.R50000]

Notice of Inventory Completion: University of Oregon Natural and Cultural History, Eugene, OR

AGENCY: National Park Service, Interior.

ACTION: Notice.

SUMMARY: In accordance with the Native American Graves Protection and Repatriation Act (NAGPRA), the University of Oregon Museum of Natural and Cultural History has completed an inventory of human remains and has determined that there is a cultural affiliation between the human remains and Indian Tribes or Native Hawaiian organizations in this notice. The human remains were removed from Tillamook County, OR.

DATES: Repatriation of the human remains in this notice may occur on or after April 8, 2024.

ADDRESSES: Dr. Pamela Endzweig, Director of Anthropological Collections, University of Oregon Museum of Natural and Cultural History, 1224 University of Oregon, Eugene, OR 97403-1224, telephone (541) 346-5120, email endzweig@uoregon.edu.

SUPPLEMENTARY INFORMATION: This notice is published as part of the National Park Service's administrative responsibilities under NAGPRA. The determinations in this notice are the sole responsibility of the University of Oregon Museum of Natural and Cultural History. The National Park Service is not responsible for the determinations in this notice. Additional information on the determinations in this notice, including the results of consultation, can be found in the inventory or related records held by the University of Oregon Museum of Natural and Cultural History.

Description

In 1957, human remains representing, at minimum, one individual were removed from Netarts Bays sand spit (35Ti1A), in Tillamook County, OR. They were collected during legally authorized excavations by University of Oregon archeologists and accessioned under Accession Number 163. The human remains are isolates collected in fill from units 7-8x/6-8y (cat.# B1437), 7-8x/8-10y (no cat.#), and 7-9x/4-6y (cat.# B1438), likely associated with House 12. They were found in the Museum's collections during study of non-human faunal remains from the

site. The human remains represent one adult, possibly male, 40-45 years old. No associated funerary objects are present.

According to published materials, most radiocarbon dates indicate that houses at 35Ti1A were in use for at least several hundred years, from ca. 1400-1800 CE.

Cultural Affiliation

The human remains and associated funerary objects in this notice are connected to one or more identifiable earlier groups, tribes, peoples, or cultures. There is a relationship of shared group identity between the identifiable earlier groups, tribes, peoples, or cultures and one or more Indian Tribes or Native Hawaiian organizations. The following types of information were used to reasonably trace the relationship: anthropological information, geographical information, historical information.

Determinations

Pursuant to NAGPRA and its implementing regulations, and after consultation with the appropriate Indian Tribes and Native Hawaiian organizations, the University of Oregon Museum of Natural and Cultural History has determined that:

- The human remains described in this notice represent the physical remains of one individual of Native American ancestry.
- There is a relationship of shared group identity that can be reasonably traced between the human remains described in this notice and the Confederated Tribes of Siletz Indians of Oregon and the Confederated Tribes of the Grand Ronde Community of Oregon.

Requests for Repatriation

Written requests for repatriation of the human remains in this notice must be sent to the Responsible Official identified in **ADDRESSES**. Requests for repatriation may be submitted by:

1. Any one or more of the Indian Tribes or Native Hawaiian organizations identified in this notice.
2. Any lineal descendant, Indian Tribe, or Native Hawaiian organization not identified in this notice who shows, by a preponderance of the evidence, that the requestor is a lineal descendant or a culturally affiliated Indian Tribe or Native Hawaiian organization.

Repatriation of the human remains in this notice to a requestor may occur on or after April 8, 2024. If competing requests for repatriation are received, the University of Oregon Museum of Natural and Cultural History must determine the most appropriate

requestor prior to repatriation. Requests for joint repatriation of the human remains are considered a single request and not competing requests. The University of Oregon Museum of Natural and Cultural History is responsible for sending a copy of this notice to the Indian Tribes and Native Hawaiian organizations identified in this notice.

This notice was submitted before the effective date of the revised regulations (88 FR 86452, December 13, 2023, effective January 12, 2024). As the notice conforms to the mandatory format of the **Federal Register** and includes the required information, the National Park Service is publishing this notice as submitted.

Authority: Native American Graves Protection and Repatriation Act, 25 U.S.C. 3003, and the implementing regulations, 43 CFR 10.10.

Dated: February 29, 2024.

Melanie O'Brien,

Manager, National NAGPRA Program.

[FR Doc. 2024-04983 Filed 3-7-24; 8:45 am]

BILLING CODE 4312-52-P

DEPARTMENT OF THE INTERIOR

National Park Service

[NPS-WASO-NAGPRA-NPS0037568; PPWOCRADN0-PCU00RP14.R50000]

Notice of Intent To Repatriate Cultural Items Amendment: California State University, Sacramento, Sacramento, CA

AGENCY: National Park Service, Interior.

ACTION: Notice; amendment.

SUMMARY: In accordance with the Native American Graves Protection and Repatriation Act (NAGPRA), the California State University, Sacramento has amended a Notice of Intent to Repatriate Cultural Items published in the **Federal Register** on March 2, 2023. This notice amends the cultural affiliation in a collection removed from Amador County, CA.

DATES: Repatriation of the cultural items in this notice may occur on or after April 8, 2024.

ADDRESSES: Dr. Mark Wheeler, Chief of Staff to President Luke Wood, California State University, Sacramento, 6000 J Street, Sacramento, CA 95819, telephone (916) 460-0490, email mark.wheeler@csus.edu.

SUPPLEMENTARY INFORMATION: This notice is published as part of the National Park Service's administrative responsibilities under NAGPRA. The determinations in this notice are the

sole responsibility of the California State University, Sacramento. The National Park Service is not responsible for the determinations in this notice. Additional information on the amendments and determinations in this notice, including the results of consultation, can be found in the summary or related records held by the California State University, Sacramento.

Amendment

This notice amends the determinations published in a Notice of Intent to Repatriate Cultural Items in the **Federal Register** (88 FR 13146, March 2, 2023). Repatriation of the items in the original Notice of Intent to Repatriate Cultural Items has not occurred. This notice amends the Tribes listed in the determinations section. Additional information of cultural affiliation was provided to support the addition of the Ione Band of Miwok Indians of California.

Determinations (as Amended)

Pursuant to NAGPRA and its implementing regulations, and after consultation with the appropriate Indian Tribes and Native Hawaiian organizations, the California State University, Sacramento has determined that:

- The 108 cultural items described above have ongoing historical, traditional, or cultural importance central to the Native American group or culture itself, rather than property owned by an individual.
- There is a relationship of shared group identity that can be reasonably traced between the cultural items in this notice and the Buena Vista Rancheria of Me-Wuk Indians of California and the Ione Band of Miwok Indians of California.

Requests for Repatriation

Additional, written requests for repatriation of the cultural items in this notice must be sent to the Responsible Official identified in **ADDRESSES**. Requests for repatriation may be submitted by any lineal descendant, Indian Tribe, or Native Hawaiian organization not identified in this notice who shows, by a preponderance of the evidence, that the requestor is a lineal descendant or a culturally affiliated Indian Tribe or Native Hawaiian organization.

Repatriation of the cultural items in this notice to a requestor may occur on or after April 8, 2024. If competing requests for repatriation are received, the California State University, Sacramento must determine the most appropriate requestor prior to

repatriation. Requests for joint repatriation of the cultural items are considered a single request and not competing requests. The California State University, Sacramento is responsible for sending a copy of this notice to the Indian Tribes and Native Hawaiian organizations identified in this notice.

Authority: Native American Graves Protection and Repatriation Act, 25 U.S.C. 3004, and the implementing regulations, 43 CFR 10.9.

Dated: February 29, 2024.

Melanie O'Brien,

Manager, National NAGPRA Program.

[FR Doc. 2024-04991 Filed 3-7-24; 8:45 am]

BILLING CODE 4312-52-P

DEPARTMENT OF THE INTERIOR

National Park Service

[NPS-WASO-NAGPRA-NPS0037570; PPWOCRADN0-PCU00RP14.R50000]

Notice of Intent To Repatriate Cultural Items: California State University, Sacramento, Sacramento, CA, and East Bay Municipal Utility District, Oakland, CA

AGENCY: National Park Service, Interior.

ACTION: Notice.

SUMMARY: In accordance with the Native American Graves Protection and Repatriation Act (NAGPRA), California State University, Sacramento and East Bay Municipal Utility District (EBMUD) intend to repatriate certain cultural items that meet the definition of objects of cultural patrimony and that have a cultural affiliation with the Indian Tribes or Native Hawaiian organizations in this notice.

DATES: Repatriation of the cultural items in this notice may occur on or after April 8, 2024.

ADDRESSES: Dr. Mark Wheeler, Chief of Staff to President Luke Wood, California State University, Sacramento, 6000 J Street, Sacramento, CA 95819, telephone (916) 460-0490, email mark.wheeler@csus.edu, and Chuck Beckman, Manager of Watershed and Recreation, East Bay Municipal Utility District, 15083 Camanche Parkway South, Valley Springs, CA 95252, telephone (209) 772-8203, email 1855harles.beckman@ebmud.com.

SUPPLEMENTARY INFORMATION: This notice is published as part of the National Park Service's administrative responsibilities under NAGPRA. The determinations in this notice are the sole responsibility of California State University, Sacramento and EBMUD, and additional information on the

determinations in this notice, including the results of consultation, can be found in the summary or related records. The National Park Service is not responsible for the determinations in this notice.

Abstract of Information Available

The 18,984 cultural items were removed from several sites in Amador County, CA. In the 1950s and 1960s, California State University, Sacramento conducted various surveys and excavations prior to the inundation of Camanche Reservoir, variously under the direction of William Beeson, Jerald Johnson, Louis Payen, William Hansen, and David Boloyan. These sites include AMA-04, AMA-05, AMA-08, AMA-45, AMA-50, and AMA-76. All collections were curated at California State University, Sacramento. The 18,984 objects of cultural patrimony include faunal and flora remains; flaked and ground stone objects; unmodified stones; historic objects; modified shell, stone and wood; baked clay; ash; ochre; soil and geologic samples; thermally altered rocks; other organic material; and unidentified material. Of this number, 978 objects are currently missing from the collections. California State University, Sacramento continues to look for these 978 missing objects.

Determinations

California State University, Sacramento and EBMUD have determined that:

- The 18,984 cultural items described above have ongoing historical, traditional, or cultural importance central to the Native American group or culture itself, including any constituent sub-group (such as a band, clan, lineage, ceremonial society, or other subdivision), according to the Native American traditional knowledge of an Indian Tribe or Native Hawaiian organization.

- There is a reasonable connection between the cultural items described in this notice and the Buena Vista Rancheria of Me-Wuk Indians of California and the Ione Band of Miwok Indians of California.

Requests for Repatriation

Additional, written requests for repatriation of the cultural items in this notice must be sent to the authorized representative identified in this notice under **ADDRESSES**. Requests for repatriation may be submitted by any lineal descendant, Indian Tribe, or Native Hawaiian organization not identified in this notice who shows, by a preponderance of the evidence, that the requestor is a lineal descendant or

a culturally affiliated Indian Tribe or Native Hawaiian organization.

Repatriation of the cultural items in this notice to a requestor may occur on or after April 8, 2024. If competing requests for repatriation are received, the California State University, Sacramento and EBMUD must determine the most appropriate requestor prior to repatriation. Requests for joint repatriation of the cultural items are considered a single request and not competing requests. The California State University, Sacramento and EBMUD is responsible for sending a copy of this notice to the Indian Tribes identified in this notice.

Authority: Native American Graves Protection and Repatriation Act, 25 U.S.C. 3004 and the implementing regulations, 43 CFR 10.9.

Dated: February 29, 2024.

Melanie O'Brien,

Manager, National NAGPRA Program.

[FR Doc. 2024-04993 Filed 3-7-24; 8:45 am]

BILLING CODE 4312-52-P

DEPARTMENT OF THE INTERIOR

National Park Service

[NPS-WASO-NAGPRA-NPS0037564; PPWOCRADNO-PCU00RP14.R50000]

Notice of Inventory Completion: William S. Webb Museum of Anthropology, University of Kentucky, Lexington, KY

AGENCY: National Park Service, Interior.

ACTION: Notice.

SUMMARY: In accordance with the Native American Graves Protection and Repatriation Act (NAGPRA), the William S. Webb Museum of Anthropology, University of Kentucky (WSWM) has completed an inventory of human remains and associated funerary objects and has determined that there is a cultural affiliation between the human remains and associated funerary objects and Indian Tribes or Native Hawaiian organizations in this notice.

DATES: Repatriation of the human remains and associated funerary objects in this notice may occur on or after April 8, 2024.

ADDRESSES: Celise Chilcote-Fricker, William S. Webb Museum of Anthropology, University of Kentucky, 1020 Export St., Lexington, KY 40504, telephone (859) 257-5124, email celise.fricker@uky.edu.

SUPPLEMENTARY INFORMATION: This notice is published as part of the National Park Service's administrative responsibilities under NAGPRA. The

determinations in this notice are the sole responsibility of the WSWM, and additional information on the determinations in this notice, including the results of consultation, can be found in the inventory or related records. The National Park Service is not responsible for the determinations in this notice.

Abstract of Information Available

Based on the information available, human remains representing, at least, one individual have been reasonably identified. No associated funerary objects are present. The site 15BE06 (Petersburg) in Boone, KY was initially excavated by the University of Kentucky Program for Cultural Resource Assessment in 1990. A Fort Ancient determination for these human remains is based on the presence of shell-tempered ceramics and contact-period burial associations.

Based on the information available, human remains representing, at least, 42 individuals have been reasonably identified. The 31 associated funerary objects are one lot lithic, seven bone beads, one cannel coal pendant, one worked cannel coal, two lots ceramic, two lots charcoal, two lots faunal, two lots floatation, two limestone disks, seven projectile points, two lots shell, and two bifaces. Site 15BB12 (Buckner) in Bourbon, KY was first excavated in 1939 by the University of Kentucky Museum of Anthropology under contract to the Works Progress Administration, surface collections in 1977 by Turnbow and Hockensmith were later donated to the WSWM and then the site was excavated again in 1987 by the University of Kentucky Field School. A Fort Ancient determination for these human remains is based on the presence of wall-trench houses, and diagnostic limestone/shell-tempered ceramics and projectile points.

Based on the information available, human remains representing, at least, one individual have been reasonably identified. No associated funerary objects are present. Site 15BB45 (New Field) in Bourbon, KY was excavated in 1992 by the University of Kentucky Program for Cultural Resource Assessment. A Fort Ancient determination for these human remains is based on the presence of shell/limestone tempered ceramics characteristic of Fort Ancient occupations in eastern Kentucky and C14 dates.

Based on the information available, nine associated funerary objects are two lots faunal, two lots ceramic, two lots lithic, two lots charcoal, and one lot floatation. Site 15BK02 (Snag Creek/

Sharp/Bradford) in Bracken, KY was excavated in 1984 by members of the William S. Webb Archaeological Society and University of Kentucky students. A Fort Ancient determination for these human remains is based on the presence of diagnostic Fox Farm and Madisonville ceramics and triangular projectile points, combined with C14 dates which suggest occupation between 1400 and 1500 CE.

Based on the information available, the seven associated funerary objects are one lot shell, one ceramic sherd, three shells, and two lithics. Burials from site 15BK04 (Augusta) in Bracken, KY were excavated by Louie Edwards while digging a basement at his house and donated to the WSWM in 1950. A Fort Ancient determination for these human remains is based on the presence of stone box burials, weeping-eye shell gorgets, shell-tempered sherds from a known Fort Ancient village site and C14 dates from 1290–1640 CE.

Based on the information available, human remains representing, at least, seven individuals have been reasonably identified. The 27 associated funerary objects are one turtle shell, three lots faunal, two lots lithic, two lithics, two lots shell, three lots charcoal, two lots ceramic sherds, six shells, one lot bone bead fragments, one bone bead, two shell beads, one copper bead, and one bone drift. Site 15BK06 (Augusta) in Bracken, KY was excavated in 2016 by the Kentucky Archaeological Survey as a salvage project related to residential basement excavation. A Fort Ancient determination for these human remains is based on the presence of diagnostic limestone/shell-tempered ceramics and projectile points.

Based on the information available, human remains representing, at least, six individuals have been reasonably identified. The 67 associated funerary objects are six lots ceramic sherds, six lots lithic, six lots shell fragments, three lots wood fragments, six lots charcoal, six lots faunal remains, one perforated human tooth, 26 shell beads and seven bone beads. Site 15BK200 (Augusta) in Bracken, KY was excavated in 2023 by the Kentucky Archaeological Survey salvage excavation from Augusta city infrastructure development. A Fort Ancient determination for these human remains is based on the presence of diagnostic limestone/shell-tempered ceramics and projectile points.

Based on the information available, human remains representing, at least, 23 individuals have been reasonably identified. No associated funerary objects are present. Site 15MS01 (Fox Farm/Fox Field) in Mason, KY was first surveyed, surface collected and

excavated by E.S. Maxwell and William S. Webb between 1920 and 1930 and donated to the University of Kentucky Museum of Anthropology. Another excavation took place in 1969 by Maysville Community College students which was donated to the Kentucky Gateway Museum Center, who then donated it to the WSWM in 2009. Additional donations to the WSWM were made by private collectors in 1960, 1991, and 2018. Additional individuals were found in the WSWM collections in 2024. A Fort Ancient determination for these human remains is based on diagnostic ceramic types, triangular projectile points, and marine shell gorgets.

Cultural Affiliation

Based on the information available and the results of consultation, cultural affiliation is clearly identified by the information available about the human remains and associated funerary objects described in this notice.

Determinations

The WSWM has determined that:

- The human remains described in this notice represent the physical remains of 80 individuals of Native American ancestry.
- The 141 objects described in this notice are reasonably believed to have been placed intentionally with or near individual human remains at the time of death or later as part of the death rite or ceremony.
- There is a reasonable connection between the human remains and associated funerary objects described in this notice and the Absentee-Shawnee Tribe of Indians of Oklahoma; Eastern Shawnee Tribe of Oklahoma; and the Shawnee Tribe.

Requests for Repatriation

Written requests for repatriation of the human remains and associated funerary objects in this notice must be sent to the authorized representative identified in this notice under **ADDRESSES**. Requests for repatriation may be submitted by:

1. Any one or more of the Indian Tribes or Native Hawaiian organizations identified in this notice.
2. Any lineal descendant, Indian Tribe, or Native Hawaiian organization not identified in this notice who shows, by a preponderance of the evidence, that the requestor is a lineal descendant or a culturally affiliated Indian Tribe or Native Hawaiian organization.

Repatriation of the human remains and associated funerary objects in this notice to a requestor may occur on or after April 8, 2024. If competing requests for repatriation are received,

the WSWM must determine the most appropriate requestor prior to repatriation. Requests for joint repatriation of the human remains and associated funerary objects are considered a single request and not competing requests. The WSWM is responsible for sending a copy of this notice to the Indian Tribes and Native Hawaiian organizations identified in this notice.

Authority: Native American Graves Protection and Repatriation Act, 25 U.S.C. 3003, and the implementing regulations, 43 CFR 10.10.

Dated: February 29, 2024.

Melanie O'Brien,

Manager, National NAGPRA Program.

[FR Doc. 2024–04989 Filed 3–7–24; 8:45 am]

BILLING CODE 4312–52–P

DEPARTMENT OF JUSTICE

Antitrust Division

Corrected Notice Pursuant to the National Cooperative Research and Production Act of 1993—Open Grid Alliance, Inc.

Notice is hereby given that, on November 16, 2023, pursuant to section 6(a) of the National Cooperative Research and Production Act of 1993, 15 U.S.C. 4301 *et seq.* (“the Act”), Open Grid Alliance, Inc. (“OGA”) has filed written notifications simultaneously with the Attorney General and the Federal Trade Commission disclosing changes in its membership. This notice corrects the notice published on February 6, 2024 (89 FR 8246), which erroneously stated that CommScope, Inc. had withdrawn from the venture. The notifications were filed for the purpose of extending the Act’s provisions limiting the recovery of antitrust plaintiffs to actual damages under specified circumstances. Specifically, Commscope, Inc. of North Carolina, Hickory, NC, has withdrawn as a party to this venture.

No other changes have been made in either the membership or planned activity of the group research project. Membership in this group research project remains open, and OGA intends to file additional written notifications disclosing all changes in membership.

On March 31, 2022, OGA filed its original notification pursuant to section 6(a) of the Act. The Department of Justice published a notice in the **Federal Register** pursuant to section 6(b) of the Act on May 12, 2022 (87 FR 29180).

The last notification was filed with the Department on August 30, 2023. A notice was published in the **Federal**

Register pursuant to section 6(b) of the Act on December 15, 2023 (88 FR 86930).

Suzanne Morris,

Deputy Director Civil Enforcement Operations, Antitrust Division.

[FR Doc. 2024-04902 Filed 3-7-24; 8:45 am]

BILLING CODE P

DEPARTMENT OF LABOR

Office of the Workers' Compensation Programs

[OMB Control No. 1240-0NEW]

Proposed New Information Collection: Claim for Schedule Award (CA-9)

AGENCY: Office of Workers' Compensation Programs, Labor.

ACTION: Request for public comments.

SUMMARY: The Department of Labor, as part of its continuing effort to reduce paperwork and respondent burden, conducts a pre-clearance request for comment to provide the general public and Federal agencies with an opportunity to comment on proposed collections of information in accordance with the Paperwork Reduction Act of 1995. This request helps to ensure that requested data can be provided in the desired format; reporting burden (time and financial resources) is minimized; collection instruments are clearly understood; and the impact of collection requirements on respondents can be properly assessed. Currently, the Office of Workers' Compensation Programs (OWCP) is soliciting comments on the information collection for Claim for Schedule Award (CA-9).

DATES: All comments must be received on or before May 7, 2024.

ADDRESSES: You may submit comment as follows. Please note that late, untimely filed comments will not be considered.

Electronic Submissions: Submit electronic comments in the following way:

- *Federal eRulemaking Portal:* <https://www.regulations.gov>. Follow the instructions for submitting comments for Claim for Schedule Award (CA-9). Comments submitted electronically, including attachments, to <https://www.regulations.gov> will be posted to the docket, with no changes. Because your comment will be made public, you are responsible for ensuring that your comment does not include any confidential information that you or a third party may not wish to be posted, such as your or anyone else's Social

Security number or confidential business information.

- If your comment includes confidential information that you do not wish to be made available to the public, submit the comment as a written/paper submission.

Written/Paper Submissions: Submit written/paper submissions in the following way:

- *Mail/Hand Delivery:* Mail or visit U.S. DOL-Office of Workers' Compensation Programs, OWCP, Room S3323, 200 Constitution Avenue NW, Washington, DC 20210.

- OWCP will post your comment as well as any attachments, except for information submitted and marked as confidential, in the docket at <https://www.regulations.gov>.

FOR FURTHER INFORMATION CONTACT:

Anjanette Suggs, Office of Workers' Compensation Programs, OWCP, at suggs.anjanette@dol.gov (email); (202) 354-9660 (voice).

SUPPLEMENTARY INFORMATION:

I. Background

The Office of Workers' Compensation Programs (OWCP) administers the Federal Employees' Compensation Act (FECA) under 5 U.S.C. 8101 *et seq.* Congress gave the Secretary of Labor (Secretary) authority to prescribe the rules and regulations necessary for the administration and enforcement of the FECA (5 U.S.C. 8149). The FECA requires the United States to provide compensation to individuals who sustain an injury while in the course of federal employment. 5 U.S.C. 8102.

Part of the compensation Congress provided for federal employees is for scheduled impairments (5 U.S.C. 8107).

Presently, under previous regulations published in 1999, schedule award claims for scheduled impairments may be filed using a form CA-7, Claim for Compensation (currently approved under OMB 1240-0046). However, the FECA regulations published June 28, 2011, also provides that OWCP may create a form specifically for a Schedule Award, and that only this form may be filed for a Schedule Award claim under 5 U.S.C. 8107. The final rule updating new procedures to the FECA regulations became effective August 29, 2011. To this end, the Department of Labor is proposing a new schedule award filing process under the provision of 20 CFR 10.103. The Department of Labor is also proposing allowing claimants to file a Schedule Award claim using a rating based on either the Fifth Edition or the Sixth Edition of the American Medical Association's Guides to the Evaluation of Permanent Impairment. As this is a

change in current policy, The Department of Labor is attaching a draft policy paper describing the need for this change in policy to be reviewed while reviewing this information collection. Schedule impairment awards are payable to an injured employee who has sustained permanent impairment to a member or function of the body pursuant to the FECA Section 8107. The relevant statutory provisions are found at 5 U.S.C. 8102 and 8107 and they read as follows:

§ 8102. Compensation for Disability or Death of Employee

(a) The United States shall pay compensation as specified by this subchapter for the disability or death of an employee resulting from personal injury sustained while in the performance of his duty, unless the injury or death is—

(1) caused by willful misconduct of the employee;

(2) caused by the employee's intention to bring about the injury or death of himself or of another; or

(3) proximately caused by the intoxication of the injured employee.

(b) Disability or death from a war-risk hazard or during or as a result of capture, detention, or other restraint by a hostile force or individual, suffered by an employee who is employed outside the continental United States or in Alaska or in the areas and installations in the Republic of Panama made available to the United States pursuant to the Panama Canal Treaty of 1977 and related agreements (as described in section 3(a) of the Panama Canal Act of 1979), is deemed to have resulted from personal injury sustained while in the performance of his duty, whether or not the employee was engaged in the course of employment when the disability or disability resulting in death occurred or when he was taken by the hostile force or individual. This subsection does not apply to an individual—

(1) whose residence is at or in the vicinity of the place of his employment and who was not living there solely because of the exigencies of his employment, unless he was injured or taken while engaged in the course of his employment; or

(2) who is a prisoner of war or a protected individual under the Geneva Conventions of 1949 and is detained or utilized by the United States.

This subsection does not affect the payment of compensation under this subchapter derived otherwise than under this subsection, but compensation for disability or death does not accrue for a period for which pay, other benefit, or gratuity from the United States

accrues to the disabled individual or his dependents on account of detention by the enemy or because of the same disability or death, unless that pay, benefit, or gratuity is refunded or renounced.

§ 8107. Compensation Schedule

(a) If there is permanent disability involving the loss, or loss of use, of a member or function of the body or involving disfigurement, the employee is entitled to basic compensation for the disability, as provided by the schedule in subsection (c) of this section, at the rate of 66⅔ percent of his monthly pay. The basic compensation is—

(1) payable regardless of whether the cause of the disability originates in a part of the body other than that member;

(2) payable regardless of whether the disability also involves another impairment of the body; and

(3) in addition to compensation for temporary total or temporary partial disability.

(b) With respect to any period after payments under subsection (a) of this section have ended, an employee is entitled to compensation as provided by—

(1) section 8105 of this title if the disability is total; or

(2) section 8106 of this title if the disability is partial.

(c) The compensation schedule is as follows:

(1) Arm lost, 312 weeks' compensation.

(2) Leg lost, 288 weeks' compensation.

(3) Hand lost, 244 weeks' compensation.

(4) Foot lost, 205 weeks' compensation.

(5) Eye lost, 160 weeks' compensation.

(6) Thumb lost, 75 weeks' compensation.

(7) First finger lost, 46 weeks' compensation.

(8) Great toe lost, 38 weeks' compensation.

(9) Second finger lost, 30 weeks' compensation.

(10) Third finger lost, 25 weeks' compensation.

(11) Toe other than great toe lost, 16 weeks' compensation.

(12) Fourth finger lost, 15 weeks' compensation.

(13) Loss of hearing—

(A) complete loss of hearing of one ear, 52 weeks' compensation; or

(B) complete loss of hearing of both ears, 200 weeks' compensation.

(14) Compensation for loss of binocular vision or for loss of 80 percent or more of the vision of an eye is the same as for loss of the eye.

(15) Compensation for loss of more than one phalanx of a digit is the same as for loss of the entire digit.

Compensation for loss of the first phalanx is one-half of the compensation for loss of the entire digit.

(16) If, in the case of an arm or a leg, the member is amputated above the wrist or ankle, compensation is the same as for loss of the arm or leg, respectively.

(17) Compensation for loss of use of two or more digits, or one or more phalanges of each of two or more digits, of a hand or foot, is proportioned to the loss of use of the hand or foot occasioned thereby.

(18) Compensation for permanent total loss of use of a member is the same as for loss of the member.

(19) Compensation for permanent partial loss of use of a member may be for proportionate loss of use of the member. The degree of loss of vision or hearing under this schedule is determined without regard to correction.

(20) In case of loss of use of more than one member or parts of more than one member as enumerated by this schedule, the compensation is for loss of use of each member or part thereof, and the awards run consecutively. However, when the injury affects only two or more digits of the same hand or foot, paragraph (17) of this subsection applies, and when partial bilateral loss of hearing is involved, compensation is computed on the loss as affecting both ears.

(21) For serious disfigurement of the face, head, or neck of a character likely to handicap an individual in securing or maintaining employment, proper and equitable compensation not to exceed \$3,500 shall be awarded in addition to any other compensation payable under this schedule.

(22) For permanent loss or loss of use of any other important external or internal organ of the body as determined by the Secretary, proper and equitable compensation not to exceed 312 weeks' compensation for each organ so determined shall be paid in addition to any other compensation payable under this schedule.

References: 5 U.S.C. 8102, 5 U.S.C. 8107, and 20 CFR 10.103. <https://www.dol.gov/agencies/owcp/FECA/regs/statutes/feca#toc>.

II. Desired Focus of Comments

OWCP is soliciting comments concerning the proposed information collection related to the Claim for Schedule Award. OWCP is particularly interested in comments that:

- Evaluate whether the collection of information is necessary for the proper performance of the functions of the Agency, including whether the information has practical utility;

- Evaluate the accuracy of OWCP's estimate of the burden related to the information collection, including the validity of the methodology and assumptions used in the estimate;

- Suggest methods to enhance the quality, utility, and clarity of the information to be collected; and

- Minimize the burden of the information collection on those who are to respond, including through the use of appropriate automated, electronic, mechanical, or other technological collection techniques or other forms of information technology, e.g., permitting electronic submission of responses.

Background documents related to this information collection request are available at <https://regulations.gov> and at DOL-OWCP located at U.S. Department of Labor, Office of Workers' Compensation Programs, Room S3323,

200 Constitution Avenue NW, Washington, DC 20210. Questions about the information collection requirements may be directed to the person listed in the **FOR FURTHER INFORMATION** section of this notice.

III. Current Actions

This information collection request concerns for the Claim for Schedule Award, CA-9. OWCP has updated the data with respect to the number of respondents, responses, burden hours, and burden costs supporting this information collection request from the previous information collection request.

Type of Review: New collection.

Agency: DOL—Office of Workers' Compensation Programs.

OMB Number: 1240-0NEW.

Affected Public: Individuals or households.

Number of Respondents: 775.

Frequency: On Occasion.

Number of Responses: 775.

Annual Burden Hours: 388 hours.

Annual Respondent or Recordkeeper Cost: \$16.00.

OWCP Forms: OWCP Form CA-9, Claim for Schedule Award.

Comments submitted in response to this notice will be summarized in the request for Office of Management and Budget approval of the proposed information collection request; they will become a matter of public record and will be available at <https://www.reginfo.gov>.

Anjanette Suggs,
Certifying Officer.

[FR Doc. 2024-04909 Filed 3-7-24; 8:45 am]

BILLING CODE 4510-CH-P

NATIONAL AERONAUTICS AND SPACE ADMINISTRATION

[NOTICE: 24–016]

Name of Information Collection: NASA STEM Gateway (Universal Registration and Data Management System)

AGENCY: National Aeronautics and Space Administration (NASA).

ACTION: Notice of information collection.

SUMMARY: The National Aeronautics and Space Administration, as part of its continuing effort to reduce paperwork and respondent burden, invites the general public and other Federal agencies to take this opportunity to comment on proposed and/or continuing information collections.

DATES: Comments are due by April 8, 2024.

ADDRESSES: Written comments and recommendations for this information collection should be sent within 30 days of publication of this notice to www.reginfo.gov/public/do/PRAMain. Find this particular information collection by selecting “Currently under 30-day Review—Open for Public Comments” or by using the search function.

FOR FURTHER INFORMATION CONTACT: Requests for additional information or copies of the information collection instrument(s) and instructions should be directed to NASA PRA Clearance Officer, Bill Edwards-Bodmer, NASA Headquarters, 300 E Street SW, JF0000, Washington, DC 20546, phone 256–714–8575, or email hq-ocio-pra-program@mail.nasa.gov.

SUPPLEMENTARY INFORMATION:

I. Abstract

Based on user feedback provided during the initial release of the NASA STEM Gateway (Universal Registration and Data Management System), NASA plans to develop updates/enhancements to improve information collected and the overall user experience in the NASA STEM Gateway. The NASA STEM Gateway (Universal Registration and Data Management System) is a comprehensive tool designed to allow learners (*i.e.*, students, educators, and awardee principal investigators) to apply to NASA STEM engagement opportunities (*e.g.*, internships, fellowships, challenges, educator professional development, experiential learning activities, etc.) in a single location. NASA personnel manage the selection of applicants and implementation of engagement opportunities within the NASA STEM

Gateway. Additionally, NASA can also deploy evaluation surveys through the NASA STEM Gateway (Universal Registration and Data Management System) to collect short- and intermediate-outcome data by surveying learners (*i.e.*, students and educators) and awardees in NASA STEM engagement activities. Results from evaluation surveys information collected will be used by the NASA Office of STEM Engagement (OSTEM) to establish better defined goals, outcomes, and standards for measuring progress and to evaluate the outcomes of NASA’s STEM Engagement programs and activities.

Authority: This process of improvement will enhance NASA’s strategic planning, performance planning, and performance reporting efforts as required by the GPRA Modernization Act of 2010 and Evidence-Based Policymaking Act of 2018.

II. Methods of Collection

Web-based.

III. Data

Title: Evaluation Surveys for NASA STEM Gateway.

OMB Number: 2700–0182.

Type of review: Renewal of a previously approved information collection.

Affected Public: Individuals. Eligible students or educators, and/or awardee principal investigators who may voluntarily complete an evaluation survey as a result of applying to or participating in a STEM engagement opportunity (*e.g.*, challenges, educator professional development, experiential learning activities, etc.).

Estimated Annual Number of Activities: 10.

Estimated Number of Respondents per Activity: 8,150.

Annual Responses: 81,500.

Estimated Time per Response: 20 minutes.

Estimated Total Annual Burden Hours: 27,167.

Estimated Total Annual Cost: \$473,481.

IV. Request for Comments

Comments are invited on: (1) Whether the proposed collection of information is necessary for the proper performance of the functions of NASA, including whether the information collected has practical utility; (2) the accuracy of NASA’s estimate of the burden (including hours and cost) of the proposed collection of information; (3) ways to enhance the quality, utility, and clarity of the information to be

collected; and (4) ways to minimize the burden of the collection of information on respondents, including automated collection techniques or the use of other forms of information technology.

Comments submitted in response to this notice will be summarized and included in the request for OMB approval of this information collection. They will also become a matter of public record.

William Edward-Bodmer,
NASA PRA Clearance Officer.

[FR Doc. 2024–04970 Filed 3–7–24; 8:45 am]

BILLING CODE 7510–13–P

NATIONAL ARCHIVES AND RECORDS ADMINISTRATION

[NARA–2024–020]

Agency Information Collection Activities: Submission for OMB Review; Comment Request

AGENCY: National Archives and Records Administration (NARA).

ACTION: Notice.

SUMMARY: NARA has submitted to OMB for approval the information collection described in this notice. We invite you to comment on this information collection.

DATES: OMB must receive written comments on or before April 8, 2024.

ADDRESSES: Send any comments and recommendations on the proposed information collection in writing to www.reginfo.gov/public/do/PRAMain. You can find this particular information collection by selecting “Currently under 30-day Review—Open for Public Comments” or by using the search function.

FOR FURTHER INFORMATION CONTACT: Tamee Fechhelm, Paperwork Reduction Act Officer, by email at tamee.fechhelm@nara.gov or by telephone at 301.837.1694 with any requests for additional information.

SUPPLEMENTARY INFORMATION: Pursuant to the Paperwork Reduction Act of 1995 (Pub. L. 104–13), we invite the public and other Federal agencies to comment on proposed information collections. We published a notice of proposed collection for this information collection on December 27, 2023 (88 FR 89478) and we received no comments. We are therefore submitting the described information collection to OMB for approval.

If you have comments or suggestions, they should address one or more of the following points: (a) whether the proposed information collection is

necessary for NARA to properly perform its functions; (b) our estimate of the burden of the proposed information collection and its accuracy; (c) ways we could enhance the quality, utility, and clarity of the information we collect; (d) ways we could minimize the burden on respondents of collecting the information, including through information technology; and (e) whether this collection affects small businesses.

In this notice, we solicit comments concerning the following information collection:

Title: Researcher Application.

OMB number: 3095–0016.

Agency form number: NA Form 14003.

Type of review: Regular.

Affected public: Individuals or households, business or other for-profit, not-for-profit institutions, Federal, State, Local or Tribal Government.

Estimated number of respondents: 7,600.

Estimated time per response: 5 minutes.

Frequency of response: On occasion.

Estimated total annual burden hours: 633 hours.

Abstract: The information collection is prescribed by 36 CFR 1254.8. The collection is an application for a research card. Respondents are individuals who wish to use original archival records in a NARA facility. NARA uses the information to screen individuals, to identify which types of records they should use, and to allow further contact.

Sheena Burrell,

Executive for Information Services/CIO.

[FR Doc. 2024–04918 Filed 3–7–24; 8:45 am]

BILLING CODE 7515–01–P

NATIONAL FOUNDATION ON THE ARTS AND THE HUMANITIES

National Endowment for the Arts

National Council on the Arts 212th Meeting

AGENCY: National Endowment for the Arts, National Foundation on the Arts and Humanities.

ACTION: Notice of meeting.

SUMMARY: Pursuant to the Federal Advisory Committee Act, as amended, notice is hereby given that a meeting of the National Council on the Arts will be held open to the public. An additional session will be closed to the public for reasons stated below.

DATES: See the **SUPPLEMENTARY INFORMATION** section for meeting time

and date. The meeting is located in eastern time and the ending time is approximate.

ADDRESSES: The National Endowment for the Arts, Constitution Center, 400 Seventh Street SW, Washington, DC 20560. Please see *arts.gov* for the most up-to-date meeting location and videoconferencing information.

FOR FURTHER INFORMATION CONTACT: Liz Auclair, Office of Public Affairs, National Endowment for the Arts, Washington, DC 20506, at 202/682–5744.

SUPPLEMENTARY INFORMATION: The meeting will take place on March 26 and 27, 2024. The meeting on March 27, 2024, from 11 a.m. to 12:30 a.m., will be open to the public. If, in the course of the open session discussion, it becomes necessary for the Council to discuss non-public commercial or financial information of intrinsic value, the Council will go into closed session pursuant to subsection (c)(4) of the Government in the Sunshine Act, 5 U.S.C. 552b, and in accordance with the March 11, 2022 determination of the Chair. Additionally, discussion concerning purely personal information about individuals, such as personal biographical and salary data or medical information, may be conducted by the Council in closed session in accordance with subsection (c)(6) of 5 U.S.C. 552b. The meeting session that occurs on March 26, 2024 will be closed to the public for the aforementioned reasons.

Detailed Meeting Information

Closed Session: March 26, 2024; 9:30 a.m. to 3 p.m. Location: Please see *arts.gov* for meeting location.

Open Session: March 27, 2024; 11 a.m. to 12:30 a.m. Location: Please see *arts.gov* for meeting location and videoconferencing information. There will be opening remarks and voting on recommendations for grant funding and rejection, updates from NEA Chair Maria Rosario Jackson, and presentations from the NEA's performing arts staff. If you need special accommodations due to a disability, please contact Beth Bienvenu, Office of Accessibility, National Endowment for the Arts, Constitution Center, 400 7th St. SW, Washington, DC 20506, 202/682–5733, Voice/T.T.Y. 202/682–5496, at least seven (7) days prior to the meeting.

Dated: March 4, 2024.

Daniel Beattie,

Director, Office of Guidelines and Panel Operations.

[FR Doc. 2024–04934 Filed 3–7–24; 8:45 am]

BILLING CODE 7537–01–P

POSTAL REGULATORY COMMISSION

[Docket Nos. MC2024–200 and CP2024–206]

New Postal Products

AGENCY: Postal Regulatory Commission.

ACTION: Notice.

SUMMARY: The Commission is noticing a recent Postal Service filing for the Commission's consideration concerning a negotiated service agreement. This notice informs the public of the filing, invites public comment, and takes other administrative steps.

DATES: *Comments are due:* March 12, 2024.

ADDRESSES: Submit comments electronically via the Commission's Filing Online system at *http://www.prc.gov*. Those who cannot submit comments electronically should contact the person identified in the **FOR FURTHER INFORMATION CONTACT** section by telephone for advice on filing alternatives.

FOR FURTHER INFORMATION CONTACT: David A. Trissell, General Counsel, at 202–789–6820.

SUPPLEMENTARY INFORMATION:

Table of Contents

- I. Introduction
- II. Docketed Proceeding(s)

I. Introduction

The Commission gives notice that the Postal Service filed request(s) for the Commission to consider matters related to negotiated service agreement(s). The request(s) may propose the addition or removal of a negotiated service agreement from the Market Dominant or the Competitive product list, or the modification of an existing product currently appearing on the Market Dominant or the Competitive product list.

Section II identifies the docket number(s) associated with each Postal Service request, the title of each Postal Service request, the request's acceptance date, and the authority cited by the Postal Service for each request. For each request, the Commission appoints an officer of the Commission to represent the interests of the general public in the proceeding, pursuant to 39 U.S.C. 505 (Public Representative). Section II also establishes comment deadline(s) pertaining to each request.

The public portions of the Postal Service's request(s) can be accessed via the Commission's website (*http://www.prc.gov*). Non-public portions of the Postal Service's request(s), if any, can be accessed through compliance

with the requirements of 39 CFR 3011.301.¹

The Commission invites comments on whether the Postal Service's request(s) in the captioned docket(s) are consistent with the policies of title 39. For request(s) that the Postal Service states concern Market Dominant product(s), applicable statutory and regulatory requirements include 39 U.S.C. 3622, 39 U.S.C. 3642, 39 CFR part 3030, and 39 CFR part 3040, subpart B. For request(s) that the Postal Service states concern Competitive product(s), applicable statutory and regulatory requirements include 39 U.S.C. 3632, 39 U.S.C. 3633, 39 U.S.C. 3642, 39 CFR part 3035, and 39 CFR part 3040, subpart B. Comment deadline(s) for each request appear in section II.

II. Docketed Proceeding(s)

1. *Docket No(s)*: MC2024–200 and CP2024–206; *Filing Title*: USPS Request to Add Priority Mail Express, Priority Mail & USPS Ground Advantage Contract 48 to Competitive Product List and Notice of Filing Materials Under Seal; *Filing Acceptance Date*: March 4, 2024; *Filing Authority*: 39 U.S.C. 3642, 39 CFR 3040.130 through 3040.135, and 39 CFR 3035.105; *Public Representative*: Jennaca D. Upperman; *Comments Due*: March 12, 2024.

This notice will be published in the **Federal Register**.

Erica A. Barker,
Secretary.

[FR Doc. 2024–04996 Filed 3–7–24; 8:45 am]

BILLING CODE 7710–FW–P

SECURITIES AND EXCHANGE COMMISSION

[Release No. 34–99667; File No. SR–CboeBZX–2023–095]

Self-Regulatory Organizations; Cboe BZX Exchange, Inc.; Order Instituting Proceedings To Determine Whether To Approve or Disapprove a Proposed Rule Change To List and Trade Shares of the Fidelity Ethereum Fund Under BZX Rule 14.11(e)(4), Commodity-Based Trust Shares

March 4, 2024.

On November 17, 2023, Cboe BZX Exchange, Inc. (“BZX” or “Exchange”) filed with the Securities and Exchange Commission (“Commission”), pursuant to section 19(b)(1) of the Securities Exchange Act of 1934 (“Act”)¹ and Rule

¹ See Docket No. RM2018–3, Order Adopting Final Rules Relating to Non-Public Information, June 27, 2018, Attachment A at 19–22 (Order No. 4679).

¹ 15 U.S.C. 78s(b)(1).

19b–4 thereunder,² a proposed rule change to list and trade shares (“Shares”) of the Fidelity Ethereum Fund (“Trust”) under BZX Rule 14.11(e)(4), Commodity-Based Trust Shares. The proposed rule change was published for comment in the **Federal Register** on December 6, 2023.³

On January 18, 2024, pursuant to section 19(b)(2) of the Act,⁴ the Commission designated a longer period within which to approve the proposed rule change, disapprove the proposed rule change, or institute proceedings to determine whether to disapprove the proposed rule change.⁵ This order institutes proceedings under section 19(b)(2)(B) of the Act⁶ to determine whether to approve or disapprove the proposed rule change.

I. Summary of the Proposal

As described in more detail in the Notice,⁷ the Exchange proposes to list and trade the Shares of the Trust under BZX Rule 14.11(e)(4), which governs the listing and trading of Commodity-Based Trust Shares on the Exchange.

The investment objective of the Trust is to seek to track the performance of ether, as measured by the performance of the Fidelity Ethereum Index (“Index”), less the Trust's expenses and other liabilities.⁸ The Trust's assets will consist of ether held by the Trust's custodian on behalf of the Trust.⁹ The Trust will value its Shares daily as of 4:00 p.m. Eastern time using the same methodology used to calculate the Index.¹⁰ The administrator of the Trust will calculate the net asset value (“NAV”) of the Trust once each Exchange trading day, and the NAV for a normal trading day will be released after 4:00 p.m. Eastern time.¹¹ For purposes of calculating the Trust's NAV per Share, the Trust's holdings of ether

² 17 CFR 240.19b–4.

³ See Securities Exchange Act Release No. 99045 (Nov. 30, 2023), 88 FR 84840 (“Notice”). Comments on the proposed rule change are available at: <https://www.sec.gov/comments/sr-cboebzx-2023-095/sr-cboebzx2023095.htm>.

⁴ 15 U.S.C. 78s(b)(2).

⁵ See Securities Exchange Act Release No. 99390, 89 FR 4639 (Jan. 24, 2024). The Commission designated March 5, 2024, as the date by which the Commission shall approve or disapprove, or institute proceedings to determine whether to disapprove, the proposed rule change.

⁶ 15 U.S.C. 78s(b)(2)(B).

⁷ See Notice, *supra* note 3.

⁸ See *id.* at 84842. FD Funds Management LLC (“Sponsor”) is the sponsor of the Trust. See *id.* at 84841.

⁹ See *id.* at 84841. The Trust generally does not intend to hold cash or cash equivalents; however, there may be situations where the Trust would unexpectedly hold cash on a temporary basis. See *id.*

¹⁰ See *id.* at 84842.

¹¹ See *id.* at 84844.

will be valued using the same methodology as used to calculate the Index.¹² When the Trust sells or redeems its Shares, it will do so in “in-kind” transactions with authorized participants in blocks of Shares.¹³

II. Proceedings To Determine Whether To Approve or Disapprove SR–CboeBZX–2023–095 and Grounds for Disapproval Under Consideration

The Commission is instituting proceedings pursuant to section 19(b)(2)(B) of the Act¹⁴ to determine whether the proposed rule change should be approved or disapproved. Institution of proceedings is appropriate at this time in view of the legal and policy issues raised by the proposed rule change, as discussed below. Institution of proceedings does not indicate that the Commission has reached any conclusions with respect to any of the issues involved. Rather, as described below, the Commission seeks and encourages interested persons to provide comments on the proposed rule change.

Pursuant to section 19(b)(2)(B) of the Act,¹⁵ the Commission is providing notice of the grounds for disapproval under consideration. The Commission is instituting proceedings to allow for additional analysis of the proposed rule change's consistency with section 6(b)(5) of the Act, which requires, among other things, that the rules of a national securities exchange be “designed to prevent fraudulent and manipulative acts and practices” and “to protect investors and the public interest.”¹⁶

The Commission asks that commenters address the sufficiency of the Exchange's statements in support of the proposal, which are set forth in the Notice, in addition to any other comments they may wish to submit about the proposed rule change. In particular, the Commission seeks comment on the following questions and asks commenters to submit data where appropriate to support their views:

1. Given the nature of the underlying assets held by the Trust, has the Exchange properly filed its proposal to list and trade the Shares under BZX

¹² See *id.* at 84843. According to the Exchange, the NAV of the Trust is calculated by taking the fair market value of its total assets based on the volume-weighted median price of ether used for the calculation of the Index, subtracting any liabilities (which include accrued expenses), and dividing that total by the total number of outstanding Shares. See *id.* at 84843–44.

¹³ See *id.* at 84844.

¹⁴ 15 U.S.C. 78s(b)(2)(B).

¹⁵ *Id.*

¹⁶ 15 U.S.C. 78f(b)(5).

Rule 14.11(e)(4), Commodity-Based Trust Shares?¹⁷

2. The Exchange raises substantially similar arguments to support the listing and trading of the Shares as those made in proposals to list and trade spot bitcoin exchange-traded products (“Bitcoin ETPs”). Do commenters agree that arguments to support the listing of Bitcoin ETPs apply equally to the Shares? Are there particular features related to ether and its ecosystem, including its proof of stake consensus mechanism and concentration of control or influence by a few individuals or entities, that raise unique concerns about ether’s susceptibility to fraud and manipulation?

3. What are commenters’ views on whether the proposed Trust and Shares would be susceptible to manipulation? What are commenters’ views generally on whether the Exchange’s proposal is designed to prevent fraudulent and manipulative acts and practices? What are commenters’ views generally with respect to the liquidity and transparency of the ether markets and the ether markets’ susceptibility to manipulation?

4. Based on data and analysis provided and the academic research cited by the Exchange,¹⁸ do commenters agree with the Exchange that the Chicago Mercantile Exchange (“CME”), on which CME ether futures trade, represents a regulated market of significant size related to spot ether?¹⁹ What are commenters’ views on whether there is a reasonable likelihood that a person attempting to manipulate the Shares would also have to trade on the CME to manipulate the Shares?²⁰ Do commenters agree with the Exchange that trading in the Shares would not be the predominant influence on prices in the CME ether futures market?²¹

5. The Exchange states that ether is resistant to price manipulation and that other means to prevent fraudulent and manipulative acts and practices “exist to justify dispensing with the requisite surveillance sharing agreement” with a regulated market of significant size

¹⁷ BZX Rule 14.11(e)(4)(C)(i) defines the term “Commodity-Based Trust Shares” as a security (a) that is issued by a trust that holds (1) a specified commodity deposited with the trust, or (2) a specified commodity and, in addition to such specified commodity, cash; (b) that is issued by such trust in a specified aggregate minimum number in return for a deposit of a quantity of the underlying commodity and/or cash; and (c) that, when aggregated in the same specified minimum number, may be redeemed at a holder’s request by such trust which will deliver to the redeeming holder the quantity of the underlying commodity and/or cash.

¹⁸ See Notice, 88 FR at 84845–49.

¹⁹ See *id.* at 84847–49.

²⁰ See *id.* at 84848–49.

²¹ See *id.* at 84849.

related to spot ether.²² In support, the Exchange states, among other things, that the geographically diverse and continuous nature of ether trading make it difficult and prohibitively costly to manipulate the price of ether, and that the fragmentation across ether platforms, the relatively slow speed of transactions, and the capital necessary to maintain a significant presence on each trading platform make manipulation of ether prices through continuous trading activity challenging.²³ Do commenters agree with the Exchange’s statements regarding the ether market’s resistance to price manipulation?

6. The Exchange also states that it will execute a surveillance-sharing agreement with Coinbase, Inc. (“Coinbase”) that is intended to supplement the Exchange’s market surveillance program.²⁴ According to the Exchange, the agreement is “expected to have the hallmarks of a surveillance-sharing agreement between two members of the [Intermarket Surveillance Group], which would give the Exchange supplemental access to data regarding spot [ether] trades on Coinbase where the Exchange determines it is necessary as part of its surveillance program for the Commodity-Based Trust Shares.”²⁵ Based on the description of the surveillance-sharing agreement as provided by the Exchange, what are commenters’ views of such an agreement if finalized and executed? Do commenters agree with the Exchange that such an agreement with Coinbase would be “helpful in detecting, investigating, and deterring fraud and market manipulation in the Commodity-Based Trust Shares”?²⁶

7. The Exchange states that there is a “similarly high correlation between spot [ether]/CME [ether] [f]utures and spot bitcoin/CME [b]itcoin [f]utures ([O].998 vs. [O].999, respectively)” and that this indicates that there is a reasonable likelihood that a person attempting to manipulate the Trust would also have to trade on the CME ether futures market.²⁷ What are commenters’ views on the correlation between the ether spot market and the CME ether futures market? What are commenters’ views on the extent to which a surveillance-

²² See *id.* at 84847 n.31.

²³ See *id.*

²⁴ See *id.* at 84849.

²⁵ See *id.* The Exchange states that “[t]his means that the Exchange expects to receive market data for orders and trades from Coinbase, which it will utilize in surveillance of the trading of Commodity-Based Trust Shares.” *Id.*

²⁶ See *id.*

²⁷ See *id.* at 84848.

sharing agreement with the CME would assist in detecting and deterring fraud and manipulation that impacts an exchange-traded product (“ETP”) that holds spot ether, and on whether the Sponsor’s daily price correlation analysis provides any evidence to this effect? What are commenters’ views generally on whether an ETP that holds CME ether futures and an ETP that holds spot ether are similar products?

III. Procedure: Request for Written Comments

The Commission requests that interested persons provide written submissions of their views, data, and arguments with respect to the issues identified above, as well as any other concerns they may have with the proposal. In particular, the Commission invites the written views of interested persons concerning whether the proposal is consistent with section 6(b)(5) or any other provision of the Act, and the rules and regulations thereunder. Although there do not appear to be any issues relevant to approval or disapproval that would be facilitated by an oral presentation of views, data, and arguments, the Commission will consider, pursuant to Rule 19b–4, any request for an opportunity to make an oral presentation.²⁸

Interested persons are invited to submit written data, views, and arguments regarding whether the proposed rule change should be approved or disapproved by March 29, 2024. Any person who wishes to file a rebuttal to any other person’s submission must file that rebuttal by April 12, 2024.

Comments may be submitted by any of the following methods:

Electronic Comments

- Use the Commission’s internet comment form (<https://www.sec.gov/rules/sro.shtml>); or
- Send an email to rule-comments@sec.gov. Please include file number SR–CboeBZX–2023–095 on the subject line.

Paper Comments

- Send paper comments in triplicate to Secretary, Securities and Exchange

²⁸ Section 19(b)(2) of the Act, as amended by the Securities Acts Amendments of 1975, Public Law 94–29 (June 4, 1975), grants the Commission flexibility to determine what type of proceeding—either oral or notice and opportunity for written comments—is appropriate for consideration of a particular proposal by a self-regulatory organization. See Securities Acts Amendments of 1975, Senate Comm. on Banking, Housing & Urban Affairs, S. Rep. No. 75, 94th Cong., 1st Sess. 30 (1975).

Commission, 100 F Street NE, Washington, DC 20549-1090.

All submissions should refer to file number SR-CboeBZX-2023-095. This file number should be included on the subject line if email is used. To help the Commission process and review your comments more efficiently, please use only one method. The Commission will post all comments on the Commission's internet website (<https://www.sec.gov/rules/sro.shtml>). Copies of the submission, all subsequent amendments, all written statements with respect to the proposed rule change that are filed with the Commission, and all written communications relating to the proposed rule change between the Commission and any person, other than those that may be withheld from the public in accordance with the provisions of 5 U.S.C. 552, will be available for website viewing and printing in the Commission's Public Reference Room, 100 F Street NE, Washington, DC 20549, on official business days between the hours of 10 a.m. and 3 p.m. Copies of the filing also will be available for inspection and copying at the principal office of the Exchange. Do not include personal identifiable information in submissions; you should submit only information that you wish to make available publicly. We may redact in part or withhold entirely from publication submitted material that is obscene or subject to copyright protection. All submissions should refer to file number SR-CboeBZX-2023-095 and should be submitted on or before March 29, 2024. Rebuttal comments should be submitted by April 12, 2024.

For the Commission, by the Division of Trading and Markets, pursuant to delegated authority.²⁹

Sherry R. Haywood,
Assistant Secretary.

[FR Doc. 2024-04929 Filed 3-7-24; 8:45 am]

BILLING CODE 8011-01-P

SECURITIES AND EXCHANGE COMMISSION

[Release No. 34-99663; File No. SR-NYSE-2024-11]

Self-Regulatory Organizations; New York Stock Exchange LLC; Notice of Filing and Immediate Effectiveness of Proposed Rule Change To Modify Rule 7.31

March 4, 2024.

Pursuant to section 19(b)(1)¹ of the Securities Exchange Act of 1934 ("Act")² and Rule 19b-4 thereunder,³ notice is hereby given that on February 26, 2024, New York Stock Exchange LLC ("NYSE" or the "Exchange") filed with the Securities and Exchange Commission (the "Commission") the proposed rule change as described in Items I and II below, which Items have been prepared by the self-regulatory organization. The Commission is publishing this notice to solicit comments on the proposed rule change from interested persons.

I. Self-Regulatory Organization's Statement of the Terms of Substance of the Proposed Rule Change

The Exchange proposes to modify Rule 7.31 regarding Discretionary Orders and Primary Pegged Orders. The proposed rule change is available on the Exchange's website at www.nyse.com, at the principal office of the Exchange, and at the Commission's Public Reference Room.

II. Self-Regulatory Organization's Statement of the Purpose of, and Statutory Basis for, the Proposed Rule Change

In its filing with the Commission, the self-regulatory organization included statements concerning the purpose of, and basis for, the proposed rule change and discussed any comments it received on the proposed rule change. The text of those statements may be examined at the places specified in Item IV below. The Exchange has prepared summaries, set forth in sections A, B, and C below, of the most significant parts of such statements.

A. Self-Regulatory Organization's Statement of the Purpose of, and the Statutory Basis for, the Proposed Rule Change

1. Purpose

The Exchange proposes to amend Rule 7.31 regarding Discretionary

Orders ("D Orders") and Primary Pegged Orders.

D Orders

Rule 7.31(d)(4) defines a D Order as a Limit Order that may trade at an undisplayed discretionary price. A D Order must be designated Day, may be designated as routable or non-routable, and on entry, must have a minimum of one round lot displayed. D Orders are available only to Floor Brokers and are eligible to be traded in the Core Trading Session only.

Rule 7.31(d)(4)(A) and subparagraphs (i) and (ii) thereunder provide that, on arrival, a Floor Broker must specify that a D Order be a Limit Price D Order or Midpoint Price D Order.⁴ Rule 7.31(d)(4)(B) provides that the working and display price of a D Order to buy (sell) will be pegged to the PBB (PBO). If the PBB (PBO) is higher (lower) than the limit price of a D Order to buy (sell), the working and display price will be the limit price of the order. A D Order to buy (sell) will be cancelled if there is no PBB (PBO) against which to peg. At its display price, a D Order is ranked Priority 2—Display Orders. As set forth in Rule 7.31(d)(4)(B)(i), if after arrival, the PBBO becomes locked or crossed, a D Order will wait for a PBBO that is not locked or crossed before the display and working price are adjusted and remains eligible to trade at its current working price.

A resting D Order to buy (sell) is eligible to exercise discretion up (down) to the limit price of the order, as described in Rule 7.31(d)(4)(C). A D Order will not exercise discretion if the PBBO is locked or crossed or if there is no Midpoint Price. Rule 7.31(d)(4)(C)(i) further provides that a D Order to buy (sell) will be triggered to exercise discretion if the price of an Aggressing Order to sell (buy) is above (below) the PBB (PBO) and at or below (above) the Midpoint Price (the "discretionary price range"). Rule 7.31(d)(4)(C)(ii) provides that the discretionary price at which a

⁴ On arrival, a Limit Price D Order to buy (sell) will trade with sell (buy) orders on the Exchange Book or, if designated as routable, route to an Away Market, up (down) to the limit price of the order. If after trading and routing the PBBO is locked or crossed or there is no PBB (PBO), a Limit Price D Order will be cancelled. For a Limit Price D Order that is partially routed to an Away Market on arrival, any returned quantity of such D Order will join the working price of the resting odd-lot quantity of the D Order. See Rule 7.31(d)(4)(A)(i). On arrival, a Midpoint Price D Order to buy (sell) will trade with sell (buy) orders on the Exchange Book up (down) to the lower (higher) of the midpoint of the PBBO ("Midpoint Price") or the limit price of the order. A Midpoint Price D Order will not route on arrival, even if designated as routable. If the PBBO is locked or crossed or if the Midpoint Price is unavailable, a Midpoint Price D Order will be rejected. See Rule 7.31(d)(4)(A)(ii).

¹ 15 U.S.C. 78s(b)(1).

² 15 U.S.C. 78a.

³ 17 CFR 240.19b-4.

²⁹ 17 CFR 200.30-3(a)(57).

D Order to buy (sell) will trade will be the price of the sell (buy) order, provided that, if there is other interest to buy (sell) on the Exchange Book priced equal to or higher (lower) than the price of the sell (buy) order, the discretionary price will be one MPV higher (lower) than the highest (lowest) priced resting order to buy (sell), capped by the Midpoint Price.

Rule 7.31(d)(4)(D) and subparagraphs (i) through (iii) thereunder describe a D Order's ranking and working time. The trigger to exercise discretion does not change the working time of a D Order's display and working price. At the discretionary price, a D Order will be assigned a new temporary working time that is later than any same-side resting interest at that price. Multiple D Orders eligible to trade at the same discretionary price will be ranked by limit price and time. Any quantity of a D Order that does not execute at a discretionary price will return to the working time associated with its working and display price.

Rule 7.31(d)(4)(E) provides that, after the PBBO unlocks or uncrosses or a Midpoint Price becomes accessible, resting D Orders to buy (sell) will be ranked based on the lower (higher) of the Midpoint Price or limit price of the order to determine whether such D Order is marketable within the discretionary price range with contra-side orders on the Exchange Book.

Finally, as provided in Rule 7.31(d)(4)(F), a D Order may be designated with an STPN or STPO modifier and will be rejected if combined with any other modifiers or if the same-side PBBO is zero.

Primary Pegged Orders

Rule 7.31(h) defines a Pegged Order as a Limit Order that does not route with a working price that is pegged to a dynamic reference price. If the designated reference price is higher (lower) than the limit price of a Pegged Order to buy (sell), the working price will be the limit price of the order. Pegged Orders are available only to Floor brokers.

Rule 7.31(h)(2) defines a Primary Pegged Order as a Pegged Order to buy (sell) with a working price that is pegged to the PBB (PBO), with no offset allowed. A Primary Pegged Order to buy (sell) will be rejected on arrival, or cancelled when resting, if there is no PBB (PBO) against which to peg. A Primary Pegged Order is eligible to participate in opening and reopening auctions at the limit price of the order but may not participate in the Closing Auction.

Rule 7.31(h)(2)(A) currently provides that a Primary Pegged Order must include a minimum of one round lot displayed. Rule 7.31(h)(2)(A) further provides that the working price of a Primary Pegged Order equals the display price, the display quantity is ranked Priority 2—Display Orders, and the reserve interest is ranked Priority 3—Non-Display Orders.

Rule 7.31(h)(2)(B) provides that a Primary Pegged Order will be rejected if the PBBO is locked or crossed. If the PBBO is locked or crossed when the display quantity of a Primary Pegged Reserve Order is replenished, the entire order will be cancelled. If after arrival, the PBBO becomes locked or crossed, the Primary Pegged Order will wait for a PBBO that is not locked or crossed before the display and working price are adjusted and remains eligible to trade at its current working price.

Proposed Rule Change

The Exchange proposes to modify Rule 7.31(d)(4) relating to D Orders and Rule 7.31(h)(2)(A) relating to Primary Pegged Orders to allow such orders to be entered in any size. Specifically, the Exchange proposes to eliminate rule text in Rules 7.31(d)(4) and 7.31(h)(2)(A) currently providing that a D Order or Primary Pegged Order must include a minimum of one round lot displayed. The Exchange believes that requiring D Orders and Primary Pegged Orders to be entered in round lots is unnecessary and that providing the option to enter D Orders and Primary Pegged Orders in odd lots could increase liquidity and enhance opportunities for order execution on the Exchange. The Exchange notes that permitting odd-lot order quantities is not novel on the Exchange or other cash equity exchanges and believes that this proposed change would align the Exchange's handling of D Orders and Primary Pegged Orders with the treatment of similar order types on other cash equity exchanges.⁵

* * * * *

⁵ See, e.g., Nasdaq Stock Market LLC ("Nasdaq") Rule 4703(g), Cboe BZX Exchange, Inc. ("BZX") Rule 11.9(c)(10), and Cboe BYX Exchange, Inc. ("BYX") Rule 11.9(c)(10) (each describing Discretionary Orders, which, like D Orders, have a non-displayed discretionary price range within which the entering party is willing to trade); Members Exchange Rule 11.8(c)(2) (describing the Primary Peg Order type similar to the Primary Pegged Order and providing that a Primary Peg Order may be entered as an odd lot, round lot, or mixed lot). The Exchange notes that the rules of Nasdaq, BZX, and BYX appear to permit orders, including order types similar to D Orders and Primary Pegged Orders, to be entered in any size. See Nasdaq Rule 4703(b) (providing that an order may be entered in any whole share size, except as otherwise provided); BZX Rule 11.2 (providing that

Because of the technology changes associated with this proposed rule change, the Exchange will announce the implementation date by Trader Update, which, subject to effectiveness of this proposed rule change, will be in the first quarter of 2024.

2. Statutory Basis

The proposed rule change is consistent with section 6(b) of the Act,⁶ in general, and furthers the objectives of section 6(b)(5),⁷ in particular, because it is designed to prevent fraudulent and manipulative acts and practices, to promote just and equitable principles of trade, to foster cooperation and coordination with persons engaged in facilitating transactions in securities, to remove impediments to, and perfect the mechanism of, a free and open market and a national market system and, in general, to protect investors and the public interest.

The Exchange believes that the proposed change would promote just and equitable principles of trade, remove impediments to, and perfect the mechanism of, a free and open market and a national market system, and protect investors and the public interest because it would permit the option to enter D Orders and Primary Pegged Orders in odd-lot sizes, which could encourage order flow to the Exchange and promote opportunities for order execution on the Exchange, to the benefit of all market participants. The Exchange notes that the proposed change would not otherwise impact the operation of D Orders or Primary Pegged Orders as provided under current Exchange rules. The Exchange also believes that the proposed change would align Exchange rules with the treatment of similar order types on other cash equity exchanges, thereby removing impediments to, and perfecting the mechanism of, a free and open market and a national market system.⁸

B. Self-Regulatory Organization's Statement on Burden on Competition

The Exchange does not believe that the proposed rule change will impose any burden on competition that is not necessary or appropriate in furtherance of the purposes of the Act. As noted above, the Exchange believes the proposed rule change would allow the Exchange to accept D Orders and Primary Pegged Orders of any size and

orders are eligible for odd-lot, round-lot, and mixed-lot executions unless otherwise indicated); BYX Rule 11.2 (same).

⁶ 15 U.S.C. 78f(b).

⁷ 15 U.S.C. 78f(b)(5).

⁸ See note 4, *supra*.

align the Exchange's handling of such orders with other cash equity exchanges' handling of similar order types,⁹ thereby promoting competition among exchanges by offering options available on other cash equity exchanges. The Exchange also believes that, to the extent the proposed change would increase opportunities for order execution, the proposed change would promote competition by making the Exchange a more attractive venue for order flow and enhancing market quality for all market participants.

C. Self-Regulatory Organization's Statement on Comments on the Proposed Rule Change Received From Members, Participants, or Others

No written comments were solicited or received with respect to the proposed rule change.

III. Date of Effectiveness of the Proposed Rule Change and Timing for Commission Action

The Exchange has filed the proposed rule change pursuant to section 19(b)(3)(A)(iii) of the Act¹⁰ and Rule 19b-4(f)(6) thereunder.¹¹ Because the proposed rule change does not: (i) significantly affect the protection of investors or the public interest; (ii) impose any significant burden on competition; and (iii) become operative prior to 30 days from the date on which it was filed, or such shorter time as the Commission may designate, if consistent with the protection of investors and the public interest, the proposed rule change has become effective pursuant to section 19(b)(3)(A) of the Act and Rule 19b-4(f)(6)(iii) thereunder.¹²

A proposed rule change filed under Rule 19b-4(f)(6)¹³ normally does not become operative prior to 30 days after the date of the filing. However, pursuant to Rule 19b-4(f)(6)(iii),¹⁴ the Commission may designate a shorter time if such action is consistent with the protection of investors and the public interest. The Exchange has asked the Commission to waive the 30-day operative delay to allow it to accept D Orders and Primary Pegged Orders of any size as soon as the technology associated with the

proposed change is available. The Exchange states that the proposal raises no novel issues and that waiver of the operative delay would allow the Exchange to more expeditiously offer increased flexibility to member organizations and promote additional trading opportunities for all market participants. The Commission finds that, because the proposal does not change the operation of D Orders or Primary Pegged Orders, other than to expand their use to odd-lot orders, waiver of the operative delay is consistent with the protection of investors and the public interest. Accordingly, the Commission hereby waives the 30-day operative delay and designates the proposal operative upon filing.¹⁵

At any time within 60 days of the filing of such proposed rule change, the Commission summarily may temporarily suspend such rule change if it appears to the Commission that such action is necessary or appropriate in the public interest, for the protection of investors, or otherwise in furtherance of the purposes of the Act. If the Commission takes such action, the Commission shall institute proceedings under section 19(b)(2)(B)¹⁶ of the Act to determine whether the proposed rule change should be approved or disapproved.

IV. Solicitation of Comments

Interested persons are invited to submit written data, views and arguments concerning the foregoing, including whether the proposed rule change is consistent with the Act. Comments may be submitted by any of the following methods:

Electronic Comments

- Use the Commission's internet comment form (<https://www.sec.gov/rules/sro.shtml>); or
- Send an email to rule-comments@sec.gov. Please include file number SR-NYSE-2024-11 on the subject line.

Paper Comments

- Send paper comments in triplicate to Secretary, Securities and Exchange Commission, 100 F Street NE, Washington, DC 20549-1090. All submissions should refer to file number SR-NYSE-2024-11. This file number should be included on the subject line if email is used. To help the Commission process and review your

¹⁵ For purposes only of accelerating the operative date of this proposal, the Commission has considered the proposed rule's impact on efficiency, competition, and capital formation. 15 U.S.C. 78c(f).

¹⁶ 15 U.S.C. 78s(b)(2)(B).

comments more efficiently, please use only one method. The Commission will post all comments on the Commission's internet website (<https://www.sec.gov/rules/sro.shtml>). Copies of the submission, all subsequent amendments, all written statements with respect to the proposed rule change that are filed with the Commission, and all written communications relating to the proposed rule change between the Commission and any person, other than those that may be withheld from the public in accordance with the provisions of 5 U.S.C. 552, will be available for website viewing and printing in the Commission's Public Reference Room, 100 F Street NE, Washington, DC 20549, on official business days between the hours of 10 a.m. and 3 p.m. Copies of the filing also will be available for inspection and copying at the principal office of the Exchange. Do not include personal identifiable information in submissions; you should submit only information that you wish to make available publicly. We may redact in part or withhold entirely from publication submitted material that is obscene or subject to copyright protection. All submissions should refer to file number SR-NYSE-2024-11 and should be submitted on or before March 29, 2024.

For the Commission, by the Division of Trading and Markets, pursuant to delegated authority.¹⁷

Sherry R. Haywood,

Assistant Secretary.

[FR Doc. 2024-04925 Filed 3-7-24; 8:45 am]

BILLING CODE 8011-01-P

SECURITIES AND EXCHANGE COMMISSION

[Release No. 34-99668; File No. SR-NYSEARCA-2024-05]

Self-Regulatory Organizations; NYSE Arca, Inc.; Notice of Designation of a Longer Period for Commission Action on a Proposed Rule Change To List and Trade Shares of the COTwo Advisors Physical European Carbon Allowance Trust Under NYSE Arca Rule 8.201-E (Commodity-Based Trust Shares)

March 4, 2024.

On January 10, 2024 NYSE Arca, Inc. filed with the Securities and Exchange Commission ("Commission"), pursuant to section 19(b)(1) of the Securities Exchange Act of 1934 ("Act")¹ and Rule

¹⁷ 17 CFR 200.30-3(a)(12).

¹ 15 U.S.C. 78s(b)(1).

⁹ *Id.*

¹⁰ 15 U.S.C. 78s(b)(3)(A)(iii).

¹¹ 17 CFR 240.19b-4(f)(6).

¹² 17 CFR 240.19b-4(f)(6)(iii). In addition, Rule 19b-4(f)(6) requires a self-regulatory organization to give the Commission written notice of its intent to file the proposed rule change at least five business days prior to the date of filing of the proposed rule change, or such shorter time as designated by the Commission. The Exchange has satisfied this requirement.

¹³ 17 CFR 240.19b-4(f)(6).

¹⁴ 17 CFR 240.19b-4(f)(6)(iii).

19b–4 thereunder,² a proposed rule change to list and trade shares of the COtwo Advisors Physical European Carbon Allowance Trust. The proposed rule change was published for comment in the **Federal Register** on January 26, 2024.³ The Commission has received no comments on the proposed rule change.

Section 19(b)(2) of the Act⁴ provides that within 45 days of the publication of notice of the filing of a proposed rule change, or within such longer period up to 90 days as the Commission may designate if it finds such longer period to be appropriate and publishes its reasons for so finding, or as to which the self-regulatory organization consents, the Commission shall either approve the proposed rule change, disapprove the proposed rule change, or institute proceedings to determine whether the proposed rule change should be disapproved. The 45th day after publication of the notice for this proposed rule change is March 11, 2024. The Commission is extending this 45-day time period.

The Commission finds it appropriate to designate a longer period within which to take action on the proposed rule change so that it has sufficient time to consider the proposed rule change. Accordingly, the Commission, pursuant to section 19(b)(2) of the Act,⁵ designates April 25, 2024 as the date by which the Commission shall either approve or disapprove, or institute proceedings to determine whether to disapprove, the proposed rule change (File No. SR–NYSEARCA–2024–05).

For the Commission, by the Division of Trading and Markets, pursuant to delegated authority.⁶

Sherry R. Haywood,

Assistant Secretary.

[FR Doc. 2024–04930 Filed 3–7–24; 8:45 am]

BILLING CODE 8011–01–P

SECURITIES AND EXCHANGE COMMISSION

[Release No. 34–99664; File No. SR–NYSECHX–2024–07]

Self-Regulatory Organizations; NYSE Chicago, Inc.; Notice of Filing and Immediate Effectiveness of Proposed Rule Change To Modify Rule 7.31

March 4, 2024.

Pursuant to section 19(b)(1)¹ of the Securities Exchange Act of 1934 (“Act”)² and Rule 19b–4 thereunder,³ notice is hereby given that, on February 26, 2024, the NYSE Chicago, Inc. (“NYSE Chicago” or the “Exchange”) filed with the Securities and Exchange Commission (the “Commission”) the proposed rule change as described in Items I, II, and III below, which Items have been prepared by the self-regulatory organization. The Commission is publishing this notice to solicit comments on the proposed rule change from interested persons.

I. Self-Regulatory Organization’s Statement of the Terms of Substance of the Proposed Rule Change

The Exchange proposes to modify Rule 7.31 regarding Primary Pegged Orders. The proposed rule change is available on the Exchange’s website at www.nyse.com, at the principal office of the Exchange, and at the Commission’s Public Reference Room.

II. Self-Regulatory Organization’s Statement of the Purpose of, and Statutory Basis for, the Proposed Rule Change

In its filing with the Commission, the self-regulatory organization included statements concerning the purpose of, and basis for, the proposed rule change and discussed any comments it received on the proposed rule change. The text of those statements may be examined at the places specified in Item IV below. The Exchange has prepared summaries, set forth in sections A, B, and C below, of the most significant parts of such statements.

A. Self-Regulatory Organization’s Statement of the Purpose of, and the Statutory Basis for, the Proposed Rule Change

1. Purpose

The Exchange proposes to amend Rule 7.31 regarding Primary Pegged Orders.

Rule 7.31(h) defines a Pegged Order as a Limit Order that does not route with

a working price that is pegged to a dynamic reference price. If the designated reference price is higher (lower) than the limit price of a Pegged Order to buy (sell), the working price will be the limit price of the order.

Rule 7.31(h)(2) defines a Primary Pegged Order as a Pegged Order to buy (sell) with a working price that is pegged to the PBB (PBO), with no offset allowed. A Primary Pegged Order to buy (sell) will be rejected on arrival, or cancelled when resting, if there is no PBB (PBO) against which to peg.

Rule 7.31(h)(2)(A) currently provides that a Primary Pegged Order must include a minimum of one round lot displayed. Rule 7.31(h)(2)(A) further provides that the working price of a Primary Pegged Order equals the display price, the display quantity is ranked Priority 2—Display Orders, and the reserve interest is ranked Priority 3—Non-Display Orders.

Rule 7.31(h)(2)(B) provides that a Primary Pegged Order will be rejected if the PBBO is locked or crossed. If the PBBO is locked or crossed when the display quantity of a Primary Pegged Reserve Order is replenished, the entire order will be cancelled. If after arrival, the PBBO becomes locked or crossed, the Primary Pegged Order will wait for a PBBO that is not locked or crossed before the display and working price are adjusted and remains eligible to trade at its current working price.

The Exchange proposes to modify Rule 7.31(h)(2)(A) to permit Primary Pegged Orders to be entered in any size and thus proposes to eliminate rule text currently providing that a Primary Pegged Order must include a minimum of one round lot displayed. The Exchange believes that requiring Primary Pegged Orders to be entered in round lots is unnecessary and that providing Participants with the option to enter Primary Pegged Orders in odd lots could increase liquidity and enhance opportunities for order execution on the Exchange. The Exchange notes that permitting odd-lot order quantities is not novel on the Exchange or other cash equity exchanges and believes that this proposed change would align the Exchange’s handling of Primary Pegged Orders with the treatment of equivalent order types on other cash equity exchanges.⁴

⁴ See, e.g., Members Exchange Rules 11.8(c)(2) (providing that a Primary Peg Order may be entered as an odd lot, round lot, or mixed lot). The Exchange also notes that the rules of the Nasdaq Stock Market LLC (“Nasdaq”), Cboe BZX Exchange, Inc. (“BZX”), and Cboe BYX Exchange, Inc. (“BYX”) appear to permit orders, including orders

Continued

² 17 CFR 240.19b–4.

³ See Securities Exchange Act Release No. 99409 (January 22, 2024), 89 FR 5273.

⁴ 15 U.S.C. 78s(b)(2).

⁵ *Id.*

⁶ 17 CFR 200.30–3(a)(31).

¹ 15 U.S.C. 78s(b)(1).

² 15 U.S.C. 78a.

³ 17 CFR 240.19b–4.

Because of the technology changes associated with this proposed rule change, the Exchange will announce the implementation date by Trader Update, which, subject to effectiveness of this proposed rule change, will be in the first quarter of 2024.

2. Statutory Basis

The proposed rule change is consistent with section 6(b) of the Act,⁵ in general, and furthers the objectives of section 6(b)(5),⁶ in particular, because it is designed to prevent fraudulent and manipulative acts and practices, to promote just and equitable principles of trade, to foster cooperation and coordination with persons engaged in facilitating transactions in securities, to remove impediments to, and perfect the mechanism of, a free and open market and a national market system and, in general, to protect investors and the public interest.

The Exchange believes that the proposed change would promote just and equitable principles of trade, remove impediments to, and perfect the mechanism of, a free and open market and a national market system, and protect investors and the public interest because it would provide Participants with the option to enter Primary Pegged Orders in odd-lot sized orders, which could encourage order flow to the Exchange and promote opportunities for order execution on the Exchange, to the benefit of all market participants. The Exchange notes that the proposed change would not otherwise impact the operation of Primary Pegged Orders as provided under current Exchange rules. The Exchange also believes that the proposed change would align Exchange rules with the treatment of orders analogous to Primary Pegged Orders on other cash equity exchanges, thereby removing impediments to, and perfecting the mechanism of, a free and open market and a national market system.⁷

B. Self-Regulatory Organization's Statement on Burden on Competition

The Exchange does not believe that the proposed rule change will impose any burden on competition that is not necessary or appropriate in furtherance of the purposes of the Act. As noted

analogous to Primary Pegged Orders, to be entered in any size. See Nasdaq Rule 4703(b) (providing that an order may be entered in any whole share size, except as otherwise provided); BZX Rule 11.2 (providing that orders are eligible for odd-lot, round-lot, and mixed-lot executions unless otherwise indicated); BYX Rule 11.2 (same).

⁵ 15 U.S.C. 78f(b).

⁶ 15 U.S.C. 78f(b)(5).

⁷ See note 4, *supra*.

above, the Exchange believes the proposed rule change would allow the Exchange to accept Primary Pegged Orders of any size and align the Exchange's handling of such orders with other cash equity exchanges' handling of similar order types,⁸ thereby promoting competition among exchanges by offering Participants options available on other cash equity exchanges. The Exchange also believes that, to the extent the proposed change would increase opportunities for order execution, the proposed change would promote competition by making the Exchange a more attractive venue for order flow and enhancing market quality for all market participants.

C. Self-Regulatory Organization's Statement on Comments on the Proposed Rule Change Received From Members, Participants, or Others

No written comments were solicited or received with respect to the proposed rule change.

III. Date of Effectiveness of the Proposed Rule Change and Timing for Commission Action

The Exchange has filed the proposed rule change pursuant to section 19(b)(3)(A)(iii) of the Act⁹ and Rule 19b-4(f)(6) thereunder.¹⁰ Because the proposed rule change does not: (i) significantly affect the protection of investors or the public interest; (ii) impose any significant burden on competition; and (iii) become operative prior to 30 days from the date on which it was filed, or such shorter time as the Commission may designate, if consistent with the protection of investors and the public interest, the proposed rule change has become effective pursuant to section 19(b)(3)(A) of the Act and Rule 19b-4(f)(6)(iii) thereunder.¹¹

A proposed rule change filed under Rule 19b-4(f)(6)¹² normally does not become operative prior to 30 days after the date of the filing. However, pursuant to Rule 19b-4(f)(6)(iii),¹³ the Commission may designate a shorter time if such action is consistent with the protection of investors and the public interest. The Exchange has asked the Commission to

⁸ *Id.*

⁹ 15 U.S.C. 78s(b)(3)(A)(iii).

¹⁰ 17 CFR 240.19b-4(f)(6).

¹¹ 17 CFR 240.19b-4(f)(6)(iii). In addition, Rule 19b-4(f)(6) requires a self-regulatory organization to give the Commission written notice of its intent to file the proposed rule change at least five business days prior to the date of filing of the proposed rule change, or such shorter time as designated by the Commission. The Exchange has satisfied this requirement.

¹² 17 CFR 240.19b-4(f)(6).

¹³ 17 CFR 240.19b-4(f)(6)(iii).

waive the 30-day operative delay to allow it to accept Primary Pegged Orders of any size as soon as the technology associated with the proposed change is available. The Exchange states that the proposal raises no novel issues and that waiver of the operative delay would allow the Exchange to more expeditiously offer increased flexibility to member organizations and promote additional trading opportunities for all market participants. The Commission finds that, because the proposal does not change the operation of Primary Pegged Orders, other than to expand their use to odd-lot orders, waiver of the operative delay is consistent with the protection of investors and the public interest. Accordingly, the Commission hereby waives the 30-day operative delay and designates the proposal operative upon filing.¹⁴

At any time within 60 days of the filing of such proposed rule change, the Commission summarily may temporarily suspend such rule change if it appears to the Commission that such action is necessary or appropriate in the public interest, for the protection of investors, or otherwise in furtherance of the purposes of the Act. If the Commission takes such action, the Commission shall institute proceedings under section 19(b)(2)(B)¹⁵ of the Act to determine whether the proposed rule change should be approved or disapproved.

IV. Solicitation of Comments

Interested persons are invited to submit written data, views and arguments concerning the foregoing, including whether the proposed rule change is consistent with the Act. Comments may be submitted by any of the following methods:

Electronic Comments

- Use the Commission's internet comment form (<https://www.sec.gov/rules/sro.shtml>); or
- Send an email to rule-comments@sec.gov. Please include file number SR-NYSECHX-2024-07 on the subject line.

Paper Comments

- Send paper comments in triplicate to Secretary, Securities and Exchange Commission, 100 F Street NE, Washington, DC 20549-1090.
- All submissions should refer to file number SR-NYSECHX-2024-07. This

¹⁴ For purposes only of accelerating the operative date of this proposal, the Commission has considered the proposed rule's impact on efficiency, competition, and capital formation. 15 U.S.C. 78c(f).

¹⁵ 15 U.S.C. 78s(b)(2)(B).

file number should be included on the subject line if email is used. To help the Commission process and review your comments more efficiently, please use only one method. The Commission will post all comments on the Commission's internet website (<https://www.sec.gov/rules/sro.shtml>). Copies of the submission, all subsequent amendments, all written statements with respect to the proposed rule change that are filed with the Commission, and all written communications relating to the proposed rule change between the Commission and any person, other than those that may be withheld from the public in accordance with the provisions of 5 U.S.C. 552, will be available for website viewing and printing in the Commission's Public Reference Room, 100 F Street NE, Washington, DC 20549, on official business days between the hours of 10 a.m. and 3 p.m. Copies of the filing also will be available for inspection and copying at the principal office of the Exchange. Do not include personal identifiable information in submissions; you should submit only information that you wish to make available publicly. We may redact in part or withhold entirely from publication submitted material that is obscene or subject to copyright protection. All submissions should refer to file number SR-NYSECHX-2024-07 and should be submitted on or before March 29, 2024.

For the Commission, by the Division of Trading and Markets, pursuant to delegated authority.¹⁶

Sherry R. Haywood,

Assistant Secretary.

[FR Doc. 2024-04926 Filed 3-7-24; 8:45 am]

BILLING CODE 8011-01-P

SECURITIES AND EXCHANGE COMMISSION

[Release No. 34-99665; File No. SR-NASDAQ-2023-045]

Self-Regulatory Organizations; The Nasdaq Stock Market LLC; Order Instituting Proceedings To Determine Whether To Approve or Disapprove a Proposed Rule Change To List and Trade Shares of the iShares Ethereum Trust Under Nasdaq Rule 5711(d), Commodity-Based Trust Shares

March 4, 2024.

On November 21, 2023, The Nasdaq Stock Market LLC ("Nasdaq" or "Exchange") filed with the Securities and Exchange Commission

("Commission"), pursuant to section 19(b)(1) of the Securities Exchange Act of 1934 ("Act")¹ and Rule 19b-4 thereunder,² a proposed rule change to list and trade shares ("Shares") of the iShares Ethereum Trust ("Trust") under Nasdaq Rule 5711(d), Commodity-Based Trust Shares. The proposed rule change was published for comment in the **Federal Register** on December 11, 2023.³

On January 24, 2024, pursuant to section 19(b)(2) of the Act,⁴ the Commission designated a longer period within which to approve the proposed rule change, disapprove the proposed rule change, or institute proceedings to determine whether to disapprove the proposed rule change.⁵ This order institutes proceedings under section 19(b)(2)(B) of the Act⁶ to determine whether to approve or disapprove the proposed rule change.

I. Summary of the Proposal

As described in more detail in the Notice,⁷ the Exchange proposes to list and trade the Shares of the Trust under Nasdaq Rule 5711(d), which governs the listing and trading of Commodity-Based Trust Shares on the Exchange.

According to the Exchange, the investment objective of the Trust is to reflect generally the performance of the price of ether, before payment of the Trust's expenses and liabilities.⁸ The assets of the Trust consist primarily of ether held by a custodian on behalf of the Trust.⁹ On each Business Day, as soon as practicable after 4:00 p.m. Eastern Time ("ET"), the administrator of the Trust will evaluate the ether held by the Trust as reflected by the CF Benchmarks Index and determine the net asset value of the Trust.¹⁰ The Trust will issue and redeem baskets of Shares on a continuous basis only in exchange for an amount of ether determined by the trustee of the Trust.¹¹

¹ 15 U.S.C. 78s(b)(1).

² 17 CFR 240.19b-4.

³ See Securities Exchange Act Release No. 99081 (Dec. 5, 2023), 88 FR 85945 ("Notice"). The Commission has received no comments on the proposal.

⁴ 15 U.S.C. 78s(b)(2).

⁵ See Securities Exchange Act Release No. 99419, 89 FR 5970 (Jan. 30, 2024). The Commission designated March 10, 2024, as the date by which the Commission shall approve or disapprove, or institute proceedings to determine whether to disapprove, the proposed rule change.

⁶ 15 U.S.C. 78s(b)(2)(B).

⁷ See Notice, *supra* note 3.

⁸ See *id.* at 85946. iShares Delaware Trust Sponsor LLC ("Sponsor") is the sponsor of the Trust and is an indirect subsidiary of BlackRock, Inc. See *id.* at 85945.

⁹ See *id.* at 85946.

¹⁰ See *id.*

¹¹ See *id.* at 85947.

II. Proceedings To Determine Whether To Approve or Disapprove SR-NASDAQ-2023-045 and Grounds for Disapproval Under Consideration

The Commission is instituting proceedings pursuant to section 19(b)(2)(B) of the Act¹² to determine whether the proposed rule change should be approved or disapproved. Institution of proceedings is appropriate at this time in view of the legal and policy issues raised by the proposed rule change, as discussed below. Institution of proceedings does not indicate that the Commission has reached any conclusions with respect to any of the issues involved. Rather, as described below, the Commission seeks and encourages interested persons to provide comments on the proposed rule change.

Pursuant to section 19(b)(2)(B) of the Act,¹³ the Commission is providing notice of the grounds for disapproval under consideration. The Commission is instituting proceedings to allow for additional analysis of the proposed rule change's consistency with section 6(b)(5) of the Act, which requires, among other things, that the rules of a national securities exchange be "designed to prevent fraudulent and manipulative acts and practices" and "to protect investors and the public interest."¹⁴

The Commission asks that commenters address the sufficiency of the Exchange's statements in support of the proposal, which are set forth in the Notice, in addition to any other comments they may wish to submit about the proposed rule change. In particular, the Commission seeks comment on the following questions and asks commenters to submit data where appropriate to support their views:

1. Given the nature of the underlying assets held by the Trust, has the Exchange properly filed its proposal to list and trade the Shares under Nasdaq Rule 5711(d), Commodity-Based Trust Shares?¹⁵

¹² 15 U.S.C. 78s(b)(2)(B).

¹³ *Id.*

¹⁴ 15 U.S.C. 78f(b)(5).

¹⁵ Nasdaq Rule 5711(d)(iv)(A) defines the term "Commodity-Based Trust Shares" as a security (1) that is issued by a trust that holds (a) a specified commodity deposited with the trust, or (b) a specified commodity and, in addition to such specified commodity, cash; (2) that is issued by such trust in a specified aggregate minimum number in return for a deposit of a quantity of the underlying commodity and/or cash; and (3) that, when aggregated in the same specified minimum number, may be redeemed at a holder's request by such trust which will deliver to the redeeming holder the quantity of the underlying commodity and/or cash.

¹⁶ 17 CFR 200.30-3(a)(12).

2. The Exchange raises substantially similar arguments to support the listing and trading of the Shares as those made in proposals to list and trade spot bitcoin exchange-traded products (“Bitcoin ETPs”). Do commenters agree that arguments to support the listing of Bitcoin ETPs apply equally to the Shares? Are there particular features related to ether and its ecosystem, including its proof of stake consensus mechanism and concentration of control or influence by a few individuals or entities, that raise unique concerns about ether’s susceptibility to fraud and manipulation?

3. What are commenters’ views on whether the proposed Trust and Shares would be susceptible to manipulation? What are commenters’ views generally on whether the Exchange’s proposal is designed to prevent fraudulent and manipulative acts and practices? What are commenters’ views generally with respect to the liquidity and transparency of the ether markets and the ether markets’ susceptibility to manipulation?

4. Based on data and analysis provided by the Exchange,¹⁶ do commenters agree with the Exchange that the Chicago Mercantile Exchange (“CME”), on which CME ether futures trade, represents a regulated market of significant size related to spot ether?¹⁷ What are commenters’ views on whether there is a reasonable likelihood that a person attempting to manipulate the Shares would also have to trade on the CME to manipulate the Shares?¹⁸ Do commenters agree with the Exchange that trading in the Shares would not be the predominant influence on prices in the CME ether futures market?¹⁹

5. The Exchange states that it will execute a surveillance-sharing agreement with Coinbase, Inc. (“Coinbase”) that is intended to supplement the Exchange’s market surveillance program.²⁰ According to the Exchange, the agreement is “expected to have the hallmarks of a surveillance-sharing agreement between two members of the [Intermarket Surveillance Group], which would give the Exchange supplemental access to data regarding spot ether trades on Coinbase where the Exchange determines it is necessary as part of its surveillance program for the Commodity-Based Trust Shares.”²¹

Based on the description of the surveillance-sharing agreement as provided by the Exchange, what are commenters’ views of such an agreement if finalized and executed? Do commenters agree with the Exchange that such an agreement with Coinbase would be “helpful in detecting, investigating, and deterring fraud and market manipulation in the Commodity-Based Trust Shares”?²²

6. The Exchange states that the “daily correlation between the spot [ether] and the CME [ether] [f]utures is 0.9993.”²³ The Exchange further states that this “high correlation” indicates that there is a reasonable likelihood that a person attempting to manipulate the Trust would also have to trade on the CME ether futures market.²⁴ What are commenters’ views on the correlation between the ether spot market and the CME ether futures market? What are commenters’ views on the extent to which a surveillance-sharing agreement with the CME would assist in detecting and deterring fraud and manipulation that impacts an exchange-traded product (“ETP”) that holds spot ether, and on whether the Exchange’s daily price correlation analysis provides any evidence to this effect? What are commenters’ views generally on whether an ETP that holds CME ether futures and an ETP that holds spot ether are similar products?

III. Procedure: Request for Written Comments

The Commission requests that interested persons provide written submissions of their views, data, and arguments with respect to the issues identified above, as well as any other concerns they may have with the proposal. In particular, the Commission invites the written views of interested persons concerning whether the proposal is consistent with section 6(b)(5) or any other provision of the Act, and the rules and regulations thereunder. Although there do not appear to be any issues relevant to approval or disapproval that would be facilitated by an oral presentation of views, data, and arguments, the Commission will consider, pursuant to Rule 19b-4, any request for an opportunity to make an oral presentation.²⁵

utilize in surveillance of the trading of Commodity-Based Trust Shares.” *Id.*

²² *See id.*

²³ *See id.* at 85950. The Exchange states that this is based on data from October 13, 2022, through October 13, 2023. *See id.*

²⁴ *See id.* at 85952.

²⁵ Section 19(b)(2) of the Act, as amended by the Securities Acts Amendments of 1975, Public Law

Interested persons are invited to submit written data, views, and arguments regarding whether the proposed rule change should be approved or disapproved by March 29, 2024. Any person who wishes to file a rebuttal to any other person’s submission must file that rebuttal by April 12, 2024.

Comments may be submitted by any of the following methods:

Electronic Comments

- Use the Commission’s internet comment form (<https://www.sec.gov/rules/sro.shtml>); or
- Send an email to rule-comments@sec.gov. Please include file number SR–NASDAQ–2023–045 on the subject line.

Paper Comments

- Send paper comments in triplicate to Secretary, Securities and Exchange Commission, 100 F Street NE, Washington, DC 20549–1090.

All submissions should refer to file number SR–NASDAQ–2023–045. This file number should be included on the subject line if email is used. To help the Commission process and review your comments more efficiently, please use only one method. The Commission will post all comments on the Commission’s internet website (<https://www.sec.gov/rules/sro.shtml>). Copies of the submission, all subsequent amendments, all written statements with respect to the proposed rule change that are filed with the Commission, and all written communications relating to the proposed rule change between the Commission and any person, other than those that may be withheld from the public in accordance with the provisions of 5 U.S.C. 552, will be available for website viewing and printing in the Commission’s Public Reference Room, 100 F Street NE, Washington, DC 20549, on official business days between the hours of 10 a.m. and 3 p.m. Copies of the filing also will be available for inspection and copying at the principal office of the Exchange. Do not include personal identifiable information in submissions; you should submit only information that you wish to make available publicly. We may redact in part or withhold entirely from publication

94–29 (June 4, 1975), grants the Commission flexibility to determine what type of proceeding—either oral or notice and opportunity for written comments—is appropriate for consideration of a particular proposal by a self-regulatory organization. *See* Securities Acts Amendments of 1975, Senate Comm. on Banking, Housing & Urban Affairs, S. Rep. No. 75, 94th Cong., 1st Sess. 30 (1975).

¹⁶ *See* Notice, 88 FR at 85950–51.

¹⁷ *See id.* at 85950–53.

¹⁸ *See id.* at 85952.

¹⁹ *See id.* at 85952–53.

²⁰ *See id.* at 85953.

²¹ *See id.* The Exchange states that “[t]his means that the Exchange expects to receive market data for orders and trades from Coinbase, which it will

submitted material that is obscene or subject to copyright protection. All submissions should refer to file number SR–NASDAQ–2023–045 and should be submitted on or before March 29, 2024. Rebuttal comments should be submitted by April 12, 2024.

For the Commission, by the Division of Trading and Markets, pursuant to delegated authority.²⁶

Sherry R. Haywood,
Assistant Secretary.

[FR Doc. 2024–04928 Filed 3–7–24; 8:45 am]

BILLING CODE 8011–01–P

DEPARTMENT OF TRANSPORTATION

Federal Aviation Administration

[Docket No. FAA–2024–0640]

Agency Information Collection Activities: Requests for Comments; Clearance of Renewed Approval of Information Collection: NAS Data Release Request

AGENCY: Federal Aviation Administration (FAA), DOT.

ACTION: Notice and request for comments.

SUMMARY: In accordance with the Paperwork Reduction Act of 1995, FAA invites public comments about our intention to request the Office of Management and Budget (OMB) approval to renew an information collection. The collection is an application form, and collection frequency is on occasion, depending on how often requests for NAS data are submitted to the FAA. The information to be collected will be used to evaluate the validity of a user's request for National Airspace (NAS) data from FAA systems and equipment.

DATES: Written comments should be submitted by May 7, 2024.

ADDRESSES: Please send written comments:

By Electronic Docket:
www.regulations.gov (Enter docket number into search field).

FOR FURTHER INFORMATION CONTACT:
Thomas Shields by email at: thomas.s-ctr.shields@faa.gov; phone: 703–946–2415.

SUPPLEMENTARY INFORMATION:

Public Comments Invited: You are asked to comment on any aspect of this information collection, including (a) Whether the proposed collection of information is necessary for FAA's performance; (b) the accuracy of the

estimated burden; (c) ways for FAA to enhance the quality, utility and clarity of the information collection; and (d) ways that the burden could be minimized without reducing the quality of the collected information. The agency will summarize and/or include your comments in the request for OMB's clearance of this information collection.

OMB Control Number: 2120–0668.

Title: NAS Data Release Request.

Form Numbers: FAA Form 1200–5.

Type of Review: Renewal of an information collection.

Background: This information collection is required to obtain or retain a benefit, which is to obtain NAS data from the FAA. This submission includes information about the entity requesting the NAS data to determine their “need to know” for the NAS data, the sensitivity of NAS data requested, the intended purpose and rationale for requiring the NAS data, and who within the requesting organization will have access to the data, including the scope and nature of work the employee will perform.

This information must be collected to enable the FAA to evaluate the “need to know” of a request for NAS data from FAA systems and equipment. The information provided by the requestor is used by the FAA NAS Data Release Board (NDRB) to approve or disapprove individual requests for NAS data, consistent with FAA Order 1200.22E External Requests for National Airspace System (NAS) Data.

Respondents: Approximately 9 requests submitted annually to the FAA by requestors of NAS data.

Frequency: On occasion.

Estimated Average Burden per Response: 1 hour.

Estimated Total Annual Burden: 9 hours total.

Issued in Washington, DC, on February 29, 2024.

David Heron,

Air Traffic Control Specialist, Strategic Operations Security Group.

[FR Doc. 2024–04922 Filed 3–7–24; 8:45 am]

BILLING CODE 4910–13–P

DEPARTMENT OF TRANSPORTATION

Federal Aviation Administration

[Docket No. FAA–2023–1263]

Agency Information Collection Activities: Requests for Comments; Clearance of Renewed Approval of Information Collection: Certification and Operations: Airplanes With Seating Capacity of 20 or More Passenger Seats or Maximum Payload of 6,000 Pounds or More

AGENCY: Federal Aviation Administration (FAA), DOT

ACTION: Notice and request for comments.

SUMMARY: In accordance with the Paperwork Reduction Act of 1995, FAA invites public comments about our intention to request Office of Management and Budget (OMB) approval to renew an information collection. This collection involves the certification and operation of aircraft with seating capacity of 20 or more passengers, or maximum payload of 6,000 pounds or more, and includes the operator application requirements, maintenance requirements, and various operational requirements.

DATES: Written comments should be submitted by April 8, 2024.

ADDRESSES: Written comments and recommendations for the proposed information collection should be sent within 30 days of publication of this notice to www.reginfo.gov/public/do/PRAMain. Find this particular information collection by selecting “Currently under 30-day Review—Open for Public Comments” or by using the search function.

FOR FURTHER INFORMATION CONTACT: John H. Attebury by email at: John.H.Attebury@faa.gov; phone: 281–929–7078.

SUPPLEMENTARY INFORMATION:

Public Comments Invited: You are asked to comment on any aspect of this information collection, including (a) Whether the proposed collection of information is necessary for FAA's performance; (b) the accuracy of the estimated burden; (c) ways for FAA to enhance the quality, utility and clarity of the information collection; and (d) ways that the burden could be minimized without reducing the quality of the collected information.

OMB Control Number: 2120–0085.

Title: Certification and Operations: Airplanes With Seating Capacity of 20 or More Passenger Seats or Maximum Payload of 6,000 Pounds or More.

Form Numbers: There are no FAA forms associated with this collection.

²⁶ 17 CFR 200.30–3(a)(57).

Type of Review: Renewal.

Background: The **Federal Register** Notice with a 60-day comment period soliciting comments on the following collection of information was published on June 16, 2023 (88 FR 39503). Title 49, United States Code, Section 44701 (formerly the Federal Aviation Act of 1958, Section 601) authorizes the Secretary of Transportation to provide for reasonable rules and regulations necessary to provide for minimum safety. 14 CFR part 125 prescribes requirements for issuing operating certificates and for appropriate operating rules. The reporting and recordkeeping requirements under this collection are necessary for the FAA to issue, reissue, and amend part 125 applicants' operating certificates and operation specifications. A letter of application and related documents that set forth an applicant's ability to conduct operations in compliance with the provisions of 14 CFR part 125 are submitted to the appropriate Flight Standards District Office (FSDO). Inspectors in FAA FSDOs review the submitted information to determine certificate eligibility. If the letter of application, related documents, and inspection show that the applicant satisfactorily meets acceptable safety standards, an operating certificate and operations specifications will be issued. If the information were not collected, the FAA could not discharge its responsibility to promote the safety of large airplane operators during such operations.

Respondents: 54 part 125 operators (38 certificated operators, 15 operators issued a Letter of Deviation Authority (LODA), and one new applicant per year).

Frequency: On occasion.

Estimated Average Burden per Response: 13 minutes.

Estimated Total Annual Burden: Approximately 36,000 hours.

Issued in Washington, DC, on March 5, 2024.

D.C. Morris,

Aviation Safety Analyst, Flight Standards Service, General Aviation and Commercial Division.

[FR Doc. 2024-04997 Filed 3-7-24; 8:45 am]

BILLING CODE 4910-13-P

DEPARTMENT OF TRANSPORTATION

Federal Motor Carrier Safety Administration

[Docket No. FMCSA-2023-0098]

Agency Information Collection Activities; Approval of a New Information Collection Request: Safety Impacts of Human-Automated Driving System (ADS) Team Driving Applications

AGENCY: Federal Motor Carrier Safety Administration (FMCSA), Department of Transportation (DOT).

ACTION: Notice and request for comments.

SUMMARY: In accordance with the Paperwork Reduction Act of 1995, FMCSA announces its plan to submit the Information Collection Request (ICR) described below to the Office of Management and Budget (OMB) for review and approval. This notice invites comments on a proposed information collection titled *Safety Impacts of Human-Automated Driving System (ADS) Team Driving Applications*. It is a driving simulator study with a series of questionnaires that will quantify the safety implications of team driving applications between humans and ADS-equipped commercial motor vehicles (CMVs). The study will assess the safety benefits and disbenefits of human-ADS team driving applications and support the analysis of potential requests for relief from FMCSA's hours of service (HOS) regulations.

DATES: Comments on this notice must be received on or before April 8, 2024.

ADDRESSES: Written comments and recommendations for the proposed information collection should be sent within 30 days of publication of this notice to www.reginfo.gov/public/do/PRAMain. Find this information collection by selecting "Currently under 30-day Review—Open for Public Comments" or by using the search function.

FOR FURTHER INFORMATION CONTACT:

Brian Routhier, Office of Research and Registration, DOT, FMCSA, West Building 6th Floor, 1200 New Jersey Avenue SE, Washington, DC 20590-0001; 202-366-1225; brian.routhier@dot.gov.

SUPPLEMENTARY INFORMATION:

Title: Safety Impacts of Human-Automated Driving System (ADS) Team Driving Applications.

OMB Control Number: 2126-00XX.

Type of Request: New ICR.

Respondents: Commercial motor vehicle drivers.

Estimated Number of Respondents: 80.

Estimated Time per Response: 17 hours.

Expiration Date: This is a new ICR.

Frequency of Response: One response.

Estimated Total Annual Burden: 508.5 hours.

Background

Over the past 15 years, ADS technology has advanced rapidly through innovation. As more manufacturers and technology companies move toward higher levels of automation (*i.e.*, SAE International Level 4 (L4)), it is not fully clear how human drivers will team with ADS-equipped trucks. L4 ADS-equipped CMVs are capable of all functions and controls necessary for driving without human monitoring in limited conditions, and the human driver will not be asked to take over control of the vehicle. L4 ADS will not operate outside of the conditions for which it was designed. Currently, there are at least four use cases where a human may team with an ADS-equipped CMV:

1. In-vehicle driver teams with an ADS CMV;
2. In-vehicle driver teams with a following ADS-equipped CMV;
3. In-vehicle driver teams with a remote assistant to monitor and control an ADS CMV; and
4. Remote driver teaming with ADS CMV.

Each of the teaming use cases above offers different potential human factors benefits and challenges. However, it is unclear how each human-ADS teaming use case will affect safety, productivity, and efficiency. Each teaming combination may positively or negatively affect a driver's cognitive workload, level of fatigue, alertness, or distraction compared to the case of a traditional driver in a truck without ADS. For example, the in-vehicle drivers and remote assistants/drivers in the above teaming use cases may experience varying workloads and differences in the development of fatigue.

Previous research conducted by FMCSA found a paucity of extant research related to ADS-equipped CMVs. To date, most commercial ADS on U.S. roadways are in passenger vehicles, and ADS-equipped CMVs are only recently being implemented in real-world operations. Therefore, FMCSA needs more data on ADS-equipped CMVs to understand the human factors surrounding team driving applications between humans and ADS-equipped CMVs.

The purpose for obtaining data in this study is to quantify safety implications of the four human-ADS teaming use cases described above. Specifically, this project will provide data to assess the safety benefits and disbenefits associated with human-ADS teaming scenarios: (i) driver use, workload, fatigue, alertness, and distraction when teaming with an ADS; (ii) remote assistant/driver use, workload, fatigue, alertness, and distraction while actively monitoring and/or controlling an ADS-equipped truck; (iii) driver re-engagement to the driving task after taking over from ADS or remote driver control; and (iv) fleet acceptance and future integration possibilities.

Additionally, data from this study will support the analysis of potential requests for relief from FMCSA's HOS regulations under 49 U.S.C. 31315 and 49 CFR part 381. Answers to these research questions will provide insight into the potential safety implications and human factors associated with human-ADS team driving applications.

The study includes data collection from a series of questionnaires and a driving-simulator focused experiment. The collected survey data will support the simulator experiment data. The survey data will be used in two ways: in the assessment of driving performance data as covariates in the model (to control for certain demographic variables, such as age, gender, and experience, and to control for previous perceptions of safety technologies) and to answer research questions on the human factors and the relationship the safety benefits of each of the four human-ADS team driving applications. Data on workload, fatigue, alertness, inattention, and performance will be collected from the simulator experiment. Eligible drivers will hold a valid commercial driver's license, currently drive a CMV, be 21 years of age or older, and pass the motion sickness history screening questionnaire.

We anticipate 80 participants in total will complete the driving simulator study. Data will be collected over one study session lasting up to 17 hours. Questionnaire data will be collected prior to the simulator study, during the simulator study, and after the simulator study. All questionnaires will be preloaded in an app format for drivers to complete on a tablet.

The analysis methodology uses a multifaceted approach to address research questions on driver workload, fatigue, alertness, distraction, and rate of safety-critical events. The principal statistical method for analyzing the data will include mixed models to account

for multiple, correlated data points from a single participant. Eye-tracking data will be used to assess driver workload, fatigue, alertness, distraction, and reaction time. These data will be described using summary statistics and advanced plotting techniques to visually compare drivers and remote drivers during in-vehicle driving, vehicle monitoring, and remote assistance/driving. A generalized linear mixed model (GLMM) will be used to assess differences in average fatigue, workload, alertness, distraction, and reaction times between in-vehicle driving and remote driving operation types. In the transportation safety field, GLMMs are often used to analyze driver behavior and assess relationships between driving scenarios and behaviors. Finally, rates of safety-critical events, including unintentional lane deviations (which are surrogates for fatigue and alertness), will be analyzed using a Poisson or negative binomial mixed-effect regression model. Poisson or negative binomial regression models are standard practice for the assessment of events over a unit of exposure in the field of transportation safety.

FMCSA published the 60-day **Federal Register** notice on June 8, 2023, and the comment period closed on August 7, 2023 (88 FR 37597). A total of three comments were received from the public. The first comment was submitted by the American Property Casualty Insurance Association (APCIA). APCIA supported the study, indicating that the study will provide important data on how human-ADS teaming may affect driver workload, fatigue, and alertness. Additionally, APCIA's comment discussed the challenges associated with developing insurance policies for ADS-equipped CMVs, which will be dependent on access to information to identify vehicles with ADS and their functions. FMCSA agrees that results from this study will provide important data on how human-ADS teaming applications affect drivers' workload and attention; however, it is not within the scope of this study to examine how the public and insurers can access information on a CMV's ADS and its functions.

The second comment was submitted by an individual. This comment expressed concerns for the safety of ADS-equipped CMVs and how ADS-equipped trucks will be compliant during a roadside inspection. FMCSA is actively engaged in many research and administrative activities to help improve the safety of CMV drivers and the general public, including research on ADS-equipped CMVs. There are many research questions that need to be

answered before ADS-equipped CMVs are deployed at scale. Some of these research questions are focused on the ADS technology itself to ensure that the ADS technology functions as intended and incorporates the appropriate redundant failsafe systems. Other research questions focus on the human factors associated with how drivers will interact and team with ADS and how law enforcement will ensure the safe operation of ADS-equipped CMVs. Results from this study, and other studies focused on ADS-equipped CMVs, will help to ensure the safety of ADS and drivers on the road.

The final comment was submitted by the Autonomous Vehicle Industry Association (AVIA). AVIA supported the study as a means to gather additional information that could be used, in part, to inform decisions in response to potential requests for relief from FMCSA's HOS under 49 U.S.C. 31315 and 49 CFR part 381. Additionally, AVIA requested that FMCSA amend the language in the study to align with terminology used in SAE J3016. Specifically, AVIA recommended replacing the term "remote monitor" with "remote assistant" and "remote operator" with "remote driver." FMCSA agrees that the use of consistent terminology is important when describing ADSs. FMCSA has revised those phrases to align with SAE J3016.

Public Comments Invited: You are asked to comment on any aspect of this information collection, including: (1) whether the proposed collection is necessary for the performance of FMCSA's functions; (2) the accuracy of the estimated burden; (3) ways for FMCSA to enhance the quality, usefulness, and clarity of the collected information; and (4) ways that the burden could be minimized without reducing the quality of the collected information.

Issued under the authority of 49 CFR 1.87.

Thomas P. Keane,

Associate Administrator, Office of Research and Registration.

[FR Doc. 2024-04923 Filed 3-7-24; 8:45 am]

BILLING CODE 4910-EX-P

DEPARTMENT OF THE TREASURY

Office of Foreign Assets Control

Notice of OFAC Sanctions Actions

AGENCY: Office of Foreign Assets Control, Treasury.

ACTION: Notice.

SUMMARY: The U.S. Department of the Treasury's Office of Foreign Assets Control (OFAC) is publishing the name of one person whose property and interests in property have been unblocked and removed from the List of Specially Designated Nationals and Blocked Persons (SDN List).

DATES: See **SUPPLEMENTARY INFORMATION** section.

FOR FURTHER INFORMATION CONTACT: OFAC: Bradley T. Smith, Director, tel.: 202-622-2490; Associate Director for Global Targeting, tel.: 202-622-2420; Assistant Director for Licensing, tel.: 202-622-2480; Assistant Director for Regulatory Affairs, tel.: 202-622-4855; or Assistant Director for Sanctions Compliance & Evaluation, tel.: 202-622-2490.

SUPPLEMENTARY INFORMATION:

Electronic Availability

The SDN List and additional information concerning OFAC sanctions programs are available on OFAC's website (<https://www.treasury.gov/ofac>).

Notice of OFAC Action

On March 5, 2024, OFAC determined that the following person would be removed from the SDN List and that their property and interests in property subject to U.S. jurisdiction are unblocked pursuant to Executive Order (E.O.) 13818. This person is no longer subject to the blocking provisions of Section 1(a) of E.O. 13818.

Individual

1. RONDON RIJO, Angel, Ave. Anaconda #83 Torre Caney Apt. 25, Santo Domingo, Dominican Republic; DOB 16 Jul 1950; POB Higuey, Dominican Republic; Gender Male; Passport SC2249384 (Dominican Republic) issued 14 Jan 2015 expires 14 Jan 2021; alt. Passport 3297843 (Dominican Republic) issued 14 Jan 2015 expires 14 Jan 2021; National ID No. 00101629970 (Dominican Republic) (individual) [GLOMAG].

Dated: March 5, 2024.

Bradley T. Smith,

Director, Office of Foreign Assets Control.

[FR Doc. 2024-04964 Filed 3-7-24; 8:45 am]

BILLING CODE 4810-AL-P

DEPARTMENT OF THE TREASURY

Internal Revenue Service

Open Meeting of the Taxpayer Advocacy Panel Joint Committee

AGENCY: Internal Revenue Service (IRS) Treasury.

ACTION: Notice of meeting.

SUMMARY: An open meeting of the Taxpayer Advocacy Panel Joint Committee will be conducted. The Taxpayer Advocacy Panel is soliciting public comments, ideas, and suggestions on improving customer service at the Internal Revenue Service. This meeting will be held via teleconference through the Microsoft Teams Platform.

DATES: The meeting will be held Monday, April 22, 2024.

FOR FURTHER INFORMATION CONTACT: Conchata Holloway at 1-888-912-1227 or 214-413-6550.

SUPPLEMENTARY INFORMATION: Notice is hereby given pursuant to section 10(a)(2) of the Federal Advisory Committee Act, 5 U.S.C. app. (1988) that an open meeting of the Taxpayer Advocacy Panel Joint Committee will be held Monday, April 22, 2024, at 1:30 p.m. eastern time via teleconference. The public is invited to make oral comments or submit written statements for consideration. For more information, please contact Conchata Holloway at 1-888-912-1227 or 214-413-6550, or write TAP Office, 1114 Commerce St. MC 1005, Dallas, TX 75242 or contact us at the website: <http://www.improveirs.org>.

The agenda will include the potential project referrals from the committees, and discussions on priorities the TAP will focus on for the 2024 year. Public input is welcomed.

Dated: February 28, 2024.

Shawn Collins,

Acting Director, Taxpayer Advocacy Panel.

[FR Doc. 2024-04919 Filed 3-7-24; 8:45 am]

BILLING CODE 4830-01-P

UNIFIED CARRIER REGISTRATION PLAN

Sunshine Act Meetings

TIME AND DATE: March 14, 2024, 12:00 p.m. to 3:00 p.m., Eastern time.

PLACE: This meeting will be accessible via conference call and via Zoom Meeting and Screenshare. Any interested person may call (i) 1-929-205-6099 (US Toll) or 1-669-900-6833 (US Toll), Meeting ID: 966 6892 4822, to listen and participate in this meeting. The website to participate via Zoom Meeting and Screenshare is <https://kellen.zoom.us/j/96668924822> or tjIrcGhrD8iGNabak6mIFVDvOfos0dZG12K.

STATUS: This meeting will be open to the public.

MATTERS TO BE CONSIDERED: The Unified Carrier Registration Plan Audit Subcommittee (the "Subcommittee") will continue its work in developing and implementing the Unified Carrier Registration Plan and Agreement. The subject matter of this meeting will include:

Proposed Agenda

I. Call to Order—UCR Audit Subcommittee Chair

The UCR Audit Subcommittee Chair will welcome attendees, call the meeting to order, call roll for the Audit Subcommittee, confirm whether a quorum is present, and facilitate self-introductions.

II. Verification of Publication of Meeting Notice—UCR Executive Director

The UCR Executive Director will verify the publication of the meeting notice on the UCR website and distribution to the UCR contact list via email followed by the subsequent publication of the notice in the **Federal Register**.

III. Review and Approval of Subcommittee Agenda and Setting of Ground Rules—UCR Audit Subcommittee Chair

For Discussion and Possible Subcommittee Action

The agenda will be reviewed, and the Subcommittee will consider adoption.

Ground Rules

Subcommittee action only to be taken in designated areas on the agenda.

IV. Review and Approval of Minutes From the November 9, 2023 Subcommittee Meeting—UCR Audit Subcommittee Chair

For Discussion and Possible Subcommittee Action

Draft minutes from the November 9, 2023 Subcommittee meeting via teleconference will be reviewed. The Subcommittee will consider action to approve.

V. Discussion of the Auto-Renew Policy Developed for the Annual Renewal of UCR Registration—UCR Audit Subcommittee Chair, UCR Audit Subcommittee Vice-Chair, UCR Executive Director and SeikoSoft Representatives

For Discussion and Possible Subcommittee Action

The UCR Audit Subcommittee Chair, UCR Audit Subcommittee Vice-Chair, UCR Executive Director, and SeikoSoft Representatives will lead a discussion on the issues involved in drafting the auto-renew policy for the voluntary annual automatic renewal of UCR registrations and options for SeikoSoft to design and implement a system that allows for the voluntary annual automatic renewal of UCR registrations using business rules developed by the Subcommittee. The Audit Subcommittee may take action to recommend that the UCR Board adopt specific language containing business and legal rules, and procedures regarding the implementation of auto-renew.

VI. Discuss Options To Review and Update the Definition of the Focused Anomaly Review (FAR)—UCR Audit Subcommittee Chair, UCR Audit Subcommittee Vice-Chair, DSL Transportation Services, Inc.

The UCR Audit Subcommittee Chair, UCR Audit Subcommittee Vice-Chair, and DSL Transportation Services, Inc., will lead a discussion on options to update/expand the definition of a FAR.

VII. Review How the Process To Clean Up the Unregistered Motor Carrier UCR Universe in Shadow MCMIS Is Working for States—UCR Audit Subcommittee Chair, UCR Audit Subcommittee Vice-Chair and a SeikoSoft Representative

For Discussion and Possible Subcommittee Action

The UCR Audit Subcommittee Chair, UCR Audit Subcommittee Vice-Chair and a Seikosoft Representative will lead a discussion on the steps necessary for the NRS and State Auditors to review and clean up the 2022/2023 unregistered motor carriers with no activity in the previous 365 days. The Subcommittee may recommend that the Board take action to approve one or more of the options discussed. The Audit Subcommittee may also take action to recommend the UCR Board adopt this proposal.

VIII. Update on Retreat Audit Program With a Program That Relies on the NRS Roadside Inspection Data—UCR Audit Subcommittee Chair, UCR Audit Subcommittee Vice-Chair, DSL Transportation Services, Inc., and a SeikoSoft Representative

The UCR Audit Subcommittee Chair, UCR Audit Subcommittee Vice Chair, DSL Transportation Services, Inc., and a SeikoSoft Representative will lead a discussion on the status of the new Retreat Audit Program that utilizes roadside inspection data for an automation driven audit for non-IRP and IRP plated commercial motor vehicles.

IX. Update the Subcommittee on the Recent Monthly Question and Answer Session for State Auditors—UCR Audit Subcommittee Chair, UCR Audit Subcommittee Vice-Chair and UCR Executive Director

The UCR Audit Subcommittee Chair, UCR Audit Subcommittee Vice-Chair, and UCR Executive Director will lead a discussion on the date, time, and subject matter of the next session in the series of 60-minute virtual question and answer sessions concerning UCR Plan audits.

X. Other Business—UCR Audit Subcommittee Chair

The UCR Audit Subcommittee Chair will call for any other items Subcommittee members would like to discuss.

XI. Adjournment—UCR Audit Subcommittee Chair

The UCR Audit Subcommittee Chair will adjourn the meeting.

The agenda will be available no later than 5:00 p.m. Eastern time, March 6, 2024 at: <https://plan.ucr.gov>.

CONTACT PERSON FOR MORE INFORMATION:

Elizabeth Leaman, Chair, Unified Carrier Registration Plan Board of Directors, (617) 305-3783, eleaman@board.ucr.gov.

Alex B. Leath,

Chief Legal Officer, Unified Carrier Registration Plan.

[FR Doc. 2024-05095 Filed 3-6-24; 4:15 pm]

BILLING CODE 4910-YL-P

DEPARTMENT OF VETERANS AFFAIRS

[OMB Control No. 2900-0889]

Agency Information Collection Activity: COVID-19 Veterans Assistance Partial Claim Payment Program

AGENCY: Veterans Benefits Administration, Department of Veterans Affairs.

ACTION: Notice.

SUMMARY: Veterans Benefits Administration, Department of Veterans Affairs (VA), is announcing an opportunity for public comment on the proposed collection of certain information by the agency. Under the Paperwork Reduction Act (PRA) of 1995, Federal agencies are required to publish notice in the **Federal Register** concerning each proposed collection of information, including each proposed revision of a currently approved collection, and allow 60 days for public comment in response to the notice.

DATES: Written comments and recommendations on the proposed collection of information should be received on or before May 7, 2024.

ADDRESSES: Submit written comments on the collection of information through Federal Docket Management System (FDMS) at www.Regulations.gov or to Nancy J. Kessinger, Veterans Benefits Administration (20M33), Department of Veterans Affairs, 810 Vermont Avenue NW, Washington, DC 20420 or email to nancy.kessinger@va.gov. Please refer to “OMB Control No. 2900-0889” in any correspondence. During the comment period, comments may be viewed online through FDMS.

FOR FURTHER INFORMATION CONTACT:

Maribel Aponte, Office of Enterprise and Integration, Data Governance Analytics (008), 810 Vermont Ave. NW, Washington, DC 20420, (202) 266-4688 or email maribel.aponte@va.gov. Please refer to “OMB Control No. 2900-0889” in any correspondence.

SUPPLEMENTARY INFORMATION: Under the PRA of 1995, Federal agencies must

obtain approval from the Office of Management and Budget (OMB) for each collection of information they conduct or sponsor. This request for comment is being made pursuant to section 3506(c)(2)(A) of the PRA.

With respect to the following collection of information, VBA invites comments on: (1) whether the proposed collection of information is necessary for the proper performance of VBA’s functions, including whether the information will have practical utility; (2) the accuracy of VBA’s estimate of the burden of the proposed collection of information; (3) ways to enhance the quality, utility, and clarity of the information to be collected; and (4) ways to minimize the burden of the collection of information on respondents, including through the use of automated collection techniques or the use of other forms of information technology.

Authority: 38 CFR 36.4803, 36.4805, 38.4806, and 38.4807.

Title: COVID-19 Veterans Assistance Partial Claim Payment Program.

OMB Control Number: 2900-0889.

Type of Review: Revision of a currently approved collection.

Abstract: This collection is necessary for VA to accept resubmissions for the COVID-19 Veterans Assistance Partial Claim Payment program (VAPCP) and continue to accept COVID-19 Refund Modifications added under this authority. The COVID-19 Refund Modification submission date was extended through May 31, 2024, and coincides with the foreclosure moratorium which also ends May 31, 2024.

Affected Public: Individuals and households.

Estimated Annual Burden: 11,670 hours.

Estimated Average Burden per Respondent: 45 minutes.

Frequency of Response: One time.

Estimated Number of Respondents: 15,560.

By direction of the Secretary.

Maribel Aponte,

VA PRA Clearance Officer, Office of Enterprise and Integration/Data Governance Analytics, Department of Veterans Affairs.

[FR Doc. 2024-04904 Filed 3-7-24; 8:45 am]

BILLING CODE 8320-01-P

DEPARTMENT OF VETERANS AFFAIRS

Advisory Committee on Disability Compensation, Notice of Meeting

The Department of Veterans Affairs (VA) gives notice under the Federal

Advisory Committee Act, 5 U.S.C. ch. 10, that the Advisory Committee on Disability Compensation (hereinafter the Committee) will hold virtual meeting sessions via the Microsoft Teams Conference Platform on Thursday, March 28, 2024 and Friday, March 29, 2024. The meeting sessions will begin, and end as follows:

Date	Time
Thursday, March 28, 2024.	10:00 a.m. to 1:00 p.m. Eastern Standard Time (EST).
Friday, March 29, 2024.	10:00 a.m. to 1:30 p.m. EST.

The meeting sessions are open to the public.

The purpose of the Committee is to advise the Secretary of Veterans Affairs on the maintenance and periodic readjustment of the VA Schedule for Rating Disabilities (VASRD). The Committee is to assemble and review relevant information relating to the needs of Veterans with disabilities; provide information relating to the nature and character of disabilities from service in the Armed Forces; provide an ongoing assessment of the effectiveness of the VASRD; and provide ongoing advice on the most appropriate means of responding to the needs of Veterans relating to disability compensation in the future.

On Thursday, March 28, 2024, and Friday, March 29, 2024, the agenda will include Committee and Federal Advisory Committee Act overview presentations, updates on the VASRD, and briefings from various staffs on new and ongoing VA initiatives and priorities.

In addition, on March 29, 2024, the public comment period will be open for 30-minutes from 12:35 p.m. to 1:05 p.m. EST. The public can also submit one-page summaries of their written statements for the Committee's review. Public comments may be received no later than March 15, 2024, for inclusion in the official meeting record. Please send these comments to Jadine Piper of the Veterans Benefits Administration, Compensation Service, at 21C_VBACO@va.gov.

Members of the public who wish to obtain a copy of the agenda should contact Jadine Piper at 21C_VBACO@va.gov, and provide their name, professional affiliation, email address, and phone number. The call-in number (United States, Chicago) for those who would like to attend the meeting is: 872-701-0185; phone conference ID: 767 051 122#. Members of the public may also access the

meeting by pasting the following URL into a web browser: <https://bit.ly/ACDCMarch2024Meeting>.

Dated: March 5, 2024.

Jelessa M. Burney,
Federal Advisory Committee Management
Officer.

[FR Doc. 2024-04969 Filed 3-7-24; 8:45 am]

BILLING CODE 8320-01-P

DEPARTMENT OF VETERANS AFFAIRS

[OMB Control No. 2900-0678]

Agency Information Collection Activity: On-The-Job Training Agreement

AGENCY: Veterans Benefits Administration, Department of Veterans Affairs.

ACTION: Notice.

SUMMARY: Veterans Benefits Administration, Department of Veterans Affairs (VA), is announcing an opportunity for public comment on the proposed collection of certain information by the agency. Under the Paperwork Reduction Act (PRA) of 1995, Federal agencies are required to publish notice in the **Federal Register** concerning each proposed collection of information, including each proposed revision of a currently approved collection, and allow 60 days for public comment in response to the notice.

DATES: Written comments and recommendations on the proposed collection of information should be received on or before May 7, 2024.

ADDRESSES: Submit written comments on the collection of information through Federal Docket Management System (FDMS) at www.Regulations.gov or to Nancy J. Kessinger, Veterans Benefits Administration (20M33), Department of Veterans Affairs, 810 Vermont Avenue NW, Washington, DC 20420 or email to nancy.kessinger@va.gov. Please refer to "OMB Control No. 2900-0678" in any correspondence. During the comment period, comments may be viewed online through FDMS.

FOR FURTHER INFORMATION CONTACT: Maribel Aponte, Office of Enterprise and Integration, Data Governance Analytics (008), 810 Vermont Ave. NW, Washington, DC 20420, (202) 266-4688 or email maribel.aponte@va.gov. Please refer to "OMB Control No. 2900-0678" in any correspondence.

SUPPLEMENTARY INFORMATION: Under the PRA of 1995, Federal agencies must obtain approval from the Office of Management and Budget (OMB) for each collection of information they conduct

or sponsor. This request for comment is being made pursuant to section 3506(c)(2)(A) of the PRA.

With respect to the following collection of information, VBA invites comments on: (1) whether the proposed collection of information is necessary for the proper performance of VBA's functions, including whether the information will have practical utility; (2) the accuracy of VBA's estimate of the burden of the proposed collection of information; (3) ways to enhance the quality, utility, and clarity of the information to be collected; and (4) ways to minimize the burden of the collection of information on respondents, including through the use of automated collection techniques or the use of other forms of information technology.

Authority: 38 U.S.C. 501(a), 38 U.S.C. 3104(a)(7), 38 U.S.C. 3116, and 38 CFR 21.212.

Title: On The Job Training Agreement.
OMB Control Number: 2900-0678.

Type of Review: Revision of a currently approved collection.

Abstract: VA Form 28-1904, On The Job Training Agreement (chapter 31, title 38 United States Code) serves as a written agreement between an On-The-Job Training (OJT) establishment and the Department of Veterans Affairs. This agreement outlines that the OJT establishment will provide competent instruction, close supervision, maintain progress reports while the Department of Veterans Affairs will furnish tools, supplies and equipment and provide supervision to the Veterans with service-connected disabilities. This agreement is necessary to ensure that the responsibilities of both parties are specified and communicated clearly. VA needs this information collection in order to assure that Veterans in these types of programs are receiving appropriate training and VA can authorize payment of tools, supplies and subsistence allowance as appropriate. This form is used to ensure understanding of the required responsibilities by both parties.

Affected Public: Individuals and households.

Estimated Annual Burden: 89 hours.

Estimated Average Burden per Respondent: 15 minutes.

Frequency of Response: One time.

Estimated Number of Respondents: 354 per year.

By direction of the Secretary.

Maribel Aponte,

VA PRA Clearance Officer, Office of Enterprise and Integration/Data Governance Analytics, Department of Veterans Affairs.

[FR Doc. 2024-04948 Filed 3-7-24; 8:45 am]

BILLING CODE 8320-01-P



FEDERAL REGISTER

Vol. 89

Friday,

No. 47

March 8, 2024

Part II

Environmental Protection Agency

40 CFR Part 60

Standards of Performance for New, Reconstructed, and Modified Sources
and Emissions Guidelines for Existing Sources: Oil and Natural Gas Sector
Climate Review; Final Rule

ENVIRONMENTAL PROTECTION AGENCY**40 CFR Part 60**

[EPA-HQ-OAR-2021-0317; FRL-8510-01-OAR]

RIN 2060-AV16

Standards of Performance for New, Reconstructed, and Modified Sources and Emissions Guidelines for Existing Sources: Oil and Natural Gas Sector Climate Review**AGENCY:** Environmental Protection Agency (EPA).**ACTION:** Final rule.

SUMMARY: The Environmental Protection Agency (EPA) is finalizing multiple actions to reduce air pollution emissions from the Crude Oil and Natural Gas source category. First, the EPA is finalizing revisions to the new source performance standards (NSPS) regulating greenhouse gases (GHGs) and volatile organic compounds (VOCs) emissions for the Crude Oil and Natural Gas source category pursuant to the Clean Air Act (CAA). Second, the EPA is finalizing emission guidelines (EG) under the CAA for states to follow in developing, submitting, and implementing state plans to establish performance standards to limit GHG emissions from existing sources (designated facilities) in the Crude Oil and Natural Gas source category. Third, the EPA is finalizing several related actions stemming from the joint resolution of Congress, adopted on June 30, 2021, under the Congressional Review Act (CRA), disapproving the EPA's final rule titled, "Oil and Natural Gas Sector: Emission Standards for New, Reconstructed, and Modified Sources Review," September 14, 2020 ("2020 Policy Rule"). Fourth, the EPA is finalizing a protocol under the general provisions for optical gas imaging (OGI).

DATES: This final rule is effective on May 7, 2024. The incorporation by reference (IBR) of certain publications listed in the rules is approved by the Director of the Federal Register as of May 7, 2024.

ADDRESSES: The EPA has established a docket for this rulemaking under Docket ID No. EPA-HQ-OAR-2021-0317. All documents in the docket are listed on the <https://www.regulations.gov/> website. Although listed, some information is not publicly available, e.g., Confidential Business Information (CBI) or other information whose disclosure is restricted by statute. Certain other material, such as copyrighted material, is not placed on

the internet and will be publicly available only in hard copy form. Publicly available docket materials are available electronically through <https://www.regulations.gov/>.

FOR FURTHER INFORMATION CONTACT: Ms. Amy Hambrick, Sector Policies and Programs Division (E143-05), Office of Air Quality Planning and Standards, U.S. Environmental Protection Agency, 109 T.W. Alexander Drive, P.O. Box 12055, Research Triangle Park, North Carolina, 27711; telephone number: (919) 541-0964; email address: hambrick.amy@epa.gov.

SUPPLEMENTARY INFORMATION: Preamble acronyms and abbreviations.

Throughout this document the use of "we," "us," or "our" is intended to refer to the EPA. We use multiple acronyms and terms in this preamble. While this list may not be exhaustive, to ease the reading of this preamble and for reference purposes, the EPA defines the following terms and acronyms here:

AMEL alternative means of emission limitation
ANSI American National Standards Institute
API American Petroleum Institute
ARPA-E Advanced Research Projects Agency-Energy
ASME American Society of Mechanical Engineers
ASTM ASTM, International
AVO audible, visual, and olfactory
AWP alternative work practice
bbl barrels of crude oil
BLM Bureau of Land Management
boe barrels of oil equivalents
BOEM Bureau of Ocean Energy Management
BSER best system of emission reduction
Btu/scf British thermal units per standard cubic foot
°C degrees Celsius
CAA Clean Air Act
CBI Confidential Business Information
CCR Code of Colorado Regulations
CDX EPA's Central Data Exchange
CEDRI Compliance and Emissions Data Reporting Interface
CFR Code of Federal Regulations
CO carbon monoxide
CO₂ carbon dioxide
CO₂ Eq. carbon dioxide equivalent
COS carbonyl sulfide
CRA Congressional Review Act
CS₂ carbon disulfide
CVS closed vent systems
D.C. Circuit U.S. Court of Appeals for the District of Columbia Circuit
DOE Department of Energy
EAV equivalent annual value
EDF Environmental Defense Fund
EG emission guidelines
EIA U.S. Energy Information Administration
EJ environmental justice
E.O. Executive Order
EPA Environmental Protection Agency
ESD emergency shutdown devices
°F degrees Fahrenheit

FEAST Fugitive Emissions Abatement Simulation Toolkit
FR Federal Register
FrEDI EPA's Framework for Evaluating Damages and Impacts model
FRFA final regulatory flexibility analysis
g/hr grams per hour
GHG greenhouse gas
GHGI Inventory of U.S. Greenhouse Gas Emissions and Sinks
GHGRP Greenhouse Gas Reporting Program
GOR gas-to-oil ratio
H₂S hydrogen sulfide
HAP hazardous air pollutant(s)
ICR information collection request
IRFA initial regulatory flexibility analysis
IWG Interagency Working Group on the Social Cost of Greenhouse Gases
kg kilograms
kg/hr kilograms per hour
kt kilotons
lb/yr pounds per year
low-E low emission
LDAR leak detection and repair
LPE legally and practicably enforceable
Mcf thousand cubic feet
MW megawatt
NAAQS national ambient air quality standards
NAICS North American Industry Classification System
NDE no detectable emissions
NIE no identifiable emissions
NESHAP national emission standards for hazardous air pollutants
NGO non-governmental organization
NHV net heating value
NO_x nitrogen oxides
NSPS new source performance standards
NTTAA National Technology Transfer and Advancement Act
O₂ oxygen
OAQPS Office of Air Quality Planning and Standards
OGI optical gas imaging
OMB Office of Management and Budget
PM particulate matter
PM_{2.5} particulate matter with a diameter of 2.5 micrometers or less
ppb parts per billion
ppm parts per million
PRA Paperwork Reduction Act
PSD prevention of significant deterioration
PTE potential to emit
PV present value
REC reduced emissions completion
RFA Regulatory Flexibility Act
RIA regulatory impact analysis
RTC response to comments
RULOF remaining useful life and other factors
SBAR Small Business Advocacy Review
SC-CH₄ social cost of methane
SC-CO₂ social cost of carbon dioxide
SC-GHG social cost of greenhouse gases
SC-N₂O social cost of nitrous oxide
scf standard cubic feet
scfh standard cubic feet per hour
scfm standard cubic feet per minute
SIP State Implementation Plan
SO₂ sulfur dioxide
SPeCS State Planning Electronic Collaboration System
tpy tons per year
the court U.S. Court of Appeals for the District of Columbia Circuit

TAR Tribal Authority Rule
 TIP Tribal Implementation Plan
 TSD technical support document
 UMRA Unfunded Mandates Reform Act
 U.S. United States
 VCS voluntary consensus standards
 VOC volatile organic compound(s)
 VRU vapor recovery unit

Organization of this document. The information in this preamble is organized as follows:

- I. General Information
 - A. Does this action apply to me?
 - B. Where can I get a copy of this document and other related information?
 - C. Judicial Review and Administrative Review
- II. Executive Summary
 - A. Purpose of the Regulatory Actions
 - B. Summary of the Major Provisions of This Regulatory Action
 - C. Costs and Benefits
- III. Air Emissions From the Crude Oil and Natural Gas Sector and Public Health and Welfare
 - A. Impacts of GHGs, VOCs, and SO₂ Emissions on Public Health and Welfare
 - B. Profile of the Oil and Natural Gas Industry and Its Emissions
- IV. Statutory Background and Regulatory History
 - A. Statutory Background of CAA Sections 111(b), 111(d), and General Implementing Regulations
 - B. What is the regulatory history and litigation background of NSPS and EG for the oil and natural gas industry?
 - C. Congressional Review Act (CRA) Joint Resolution of Disapproval
- V. Legal Basis for Final Rule Scope
 - A. Introduction
 - B. Overview
 - C. Comments
 - D. Response to Comments and Discussion
- VI. Other Actions and Related Efforts
 - A. Related State Actions and Other Federal Actions Regulating Oil and Natural Gas Sources
 - B. Industry and Voluntary Actions To Address Climate Change
 - C. Methane Emissions Reduction Program
- VII. Summary of Engagement With Pertinent Stakeholders
- VIII. Overview of Control and Control Costs
 - A. Control of Methane and VOC Emissions in the Crude Oil and Natural Gas Source Category—Overview
 - B. How does the EPA evaluate control costs in this final action?
- IX. Interaction of the Rules and Response to Significant Comments Thereon
 - A. What date defines a new, modified, or reconstructed source for purposes of the final NSPS OOOOb?
 - B. What date defines an existing source for purposes of the final EG OOOOc?
 - C. How will the final EG OOOOc impact sources already subject to NSPS KKK, NSPS OOOO, or NSPS OOOOa?
- X. Summary of Final Standards NSPS OOOOb and EG OOOOc
 - A. Fugitive Emissions From Well Sites, Centralized Production Facilities, and Compressor Stations

- B. Advanced Methane Detection Technology Work Practices
 - C. Super Emitter Program
 - D. Process Controllers
 - E. Pumps
 - F. Wells and Associated Operations
 - G. Centrifugal Compressors
 - H. Combustion Control Devices
 - I. Reciprocating Compressors
 - J. Storage Vessels
 - K. Covers and Closed Vent Systems
 - L. Equipment Leaks at Natural Gas Processing Plants
 - M. Sweetening Units
 - N. Electronic Reporting
 - O. Prevention of Significant Deterioration and Title V Permitting
- XI. Significant Comments and Changes Since Supplemental Proposal for NSPS OOOOb and EG OOOOc
 - A. Fugitive Emissions from Well Sites, Centralized Production Facilities, and Compressor Stations
 - B. Advanced Methane Detection Technology Work Practices
 - C. Super Emitter Program
 - D. Process Controllers
 - E. Pumps
 - F. Wells and Associated Operations
 - G. Centrifugal Compressors
 - H. Combustion Control Devices
 - I. Reciprocating Compressors
 - J. Storage Vessels
 - K. Covers and Closed Vent Systems
 - L. Equipment Leaks at Natural Gas Processing Plants
 - M. Sweetening Units
 - XII. Significant Comments and Changes Since Proposal for NSPS OOOOa and NSPS OOOO
 - A. Low Production Well Site Exemption Rescission
 - B. Compressor Station Quarterly Monitoring
 - C. Delay-of-Repair Provisions
 - D. Applicability/Scope of the Rule
 - XIII. Significant Comments and Changes to Emission Guidelines for State, Tribal, and Federal Plan Development for Existing Sources
 - A. Overview
 - B. Components of EG
 - C. Establishing Standards of Performance in State Plans
 - D. Components of State Plan Submission
 - E. Timing of State Plan Submissions and Compliance Times
 - F. EPA Action on State Plans and Promulgation of Federal Plans
 - G. Tribes and the Planning Process Under CAA Section 111(d)
 - XIV. Use of Optical Gas Imaging in Leak Detection (Appendix K) and Response to Significant Comments
 - A. Changes Since Supplemental Proposal
 - B. Summary of Requirements
 - XV. Prevention of Significant Deterioration and Title V Permitting
 - XVI. Summary of Cost, Environmental, and Economic Impacts
 - A. What are the air quality impacts?
 - B. What are the secondary impacts?
 - C. What are the cost impacts?
 - D. What are the economic impacts?
 - E. What are the benefits?

- F. What analyses of environmental justice did we conduct?
- XVII. Statutory and Executive Order Reviews
 - A. Executive Order 12866: Regulatory Planning and Review and Executive Order 14094: Modernizing Regulatory Review
 - B. Paperwork Reduction Act (PRA)
 - C. Regulatory Flexibility Act (RFA)
 - D. Unfunded Mandates Reform Act (UMRA)
 - E. Executive Order 13132: Federalism
 - F. Executive Order 13175: Consultation and Coordination With Indian Tribal Governments
 - G. Executive Order 13045: Protection of Children From Environmental Health Risks and Safety Risks
 - H. Executive Order 13211: Actions Concerning Regulations That Significantly Affect Energy Supply, Distribution, or Use
 - I. National Technology Transfer and Advancement Act (NTTAA) and 1 CFR Part 51
 - J. Executive Order 12898: Federal Actions To Address Environmental Justice in Minority Populations and Low-Income Populations and Executive Order 14096: Revitalizing Our Nation's Commitment to Environmental Justice for All
 - K. Congressional Review Act (CRA)

I. General Information

A. Does this action apply to me?

The source category that is the subject of this final rulemaking is composed of the Crude Oil and Natural Gas source category regulated under CAA section 111 New Source Performance Standards and Emission Guidelines. The North American Industry Classification System (NAICS) codes for the industrial source category affected by the NSPS actions finalized in this rulemaking are summarized in table 1. The NAICS codes serve as a guide for readers outlining the type of entities that the final NSPS actions are likely to affect. The NSPS codified in 40 Code of Regulations (CFR) part 60, subpart OOOOb, are directly applicable to affected facilities that begin construction, reconstruction, or modification after December 6, 2022. Final amendments to 40 CFR part 60, subpart OOOO, are applicable to affected facilities that began construction, reconstruction, or modification after August 23, 2011, and on or before September 18, 2015. Final amendments to 40 CFR part 60, subpart OOOOa, are applicable to affected facilities that began construction, reconstruction, or modification after September 18, 2015, and on or before December 6, 2022. As shown in table 1, Federal, state, and local government entities would not be affected by the NSPS actions.

TABLE 1—INDUSTRIAL SOURCE CATEGORIES AFFECTED BY NSPS ACTIONS

Category	NAICS Code ¹	Examples of regulated entities
Industry	211120 211130 221210 486110 486210	Crude Petroleum Extraction. Natural Gas Extraction. Natural Gas Distribution. Pipeline Distribution of Crude Oil. Pipeline Transportation of Natural Gas.
Federal Government	Not affected.
State and Local Government	Not affected.
Tribal Government	921150	American Indian and Alaska Native Tribal Governments.

¹ North American Industry Classification System (NAICS).

This table is not intended to be exhaustive but rather provides a guide for readers regarding entities likely to be affected by the NSPS actions. Other types of entities not listed in the table could also be affected by these NSPS actions. To determine whether your entity is affected by any of the NSPS actions, you should carefully examine the applicability criteria found in the final NSPS rules. If you have questions regarding the applicability of the NSPS rules to a particular entity, consult the person listed in the **FOR FURTHER INFORMATION CONTACT** section, your state air pollution control agency with delegated authority for NSPS, or your EPA Regional Office.

The issuance of CAA section 111(d) final EG does not impose binding requirements directly on existing sources. The EG codified in 40 CFR part 60, subpart OOOOc, applies to states in the development, submittal, and implementation of state plans to establish performance standards to reduce emissions of GHGs from designated facilities that are existing sources on or before December 6, 2022. Under the Tribal Authority Rule (TAR), eligible Tribes may seek approval to implement a plan under CAA section 111(d) in a manner similar to a state. See 40 CFR part 49, subpart A. Tribes may, but are not required to, seek approval for treatment in a manner similar to a state for purposes of developing a Tribal implementation plan (TIP) implementing the EG codified in 40 CFR part 60, subpart OOOOc. The TAR authorizes Tribes to develop and implement their own air quality programs, or portions thereof, under the CAA. However, it does not require Tribes to develop a CAA program. Tribes may implement programs that are most relevant to their air quality needs. If a Tribe does not seek and obtain the authority from the EPA to establish a TIP, the EPA has the authority to establish a Federal CAA section 111(d) plan for designated facilities that are located in areas of

Indian country.¹ A Federal plan would apply to all designated facilities located in the areas of Indian country covered by the Federal plan unless and until the EPA approves a TIP applicable to those facilities.

B. Where can I get a copy of this document and other related information?

In addition to being available in the docket, at Docket ID No. EPA-HQ-OAR-2021-0317 located at <https://www.regulations.gov/>, an electronic copy of this final rulemaking is available on the internet at <https://www.epa.gov/controlling-air-pollution-oil-and-natural-gas-industry>. Following signature by the EPA Administrator, the EPA will post a copy of this final rulemaking at this same website. Following publication in the **Federal Register**, the EPA will post the **Federal Register** version of the final rulemaking and key technical documents at this same website.

C. Judicial Review and Administrative Review

Under Clean Air Act (CAA) section 307(b)(1), judicial review of this final rulemaking is available only by filing a petition for review in the United States Court of Appeals for the District of Columbia Circuit by May 7, 2024. Under CAA section 307(b)(2), the requirements established by this final rulemaking may not be challenged separately in any civil or criminal proceedings brought by the EPA to enforce the requirements.

Section 307(d)(7)(B) of the CAA further provides that “[o]nly an objection to a rule or procedure which was raised with reasonable specificity during the period for public comment (including any public hearing) may be raised during judicial review.” This section also provides a mechanism for

¹ See the EPA’s website, <https://www.epa.gov/tribal/tribes-approved-treatment-state-tas>, for information on those Tribes that have treatment as a state for specific environmental regulatory programs, administrative functions, and grant programs.

the EPA to convene a proceeding for reconsideration, “[i]f the person raising an objection can demonstrate to the EPA that it was impracticable to raise such objection within [the period for public comment] or if the grounds for such objection arose after the period for public comment, (but within the time specified for judicial review) and if such objection is of central relevance to the outcome of the rule.” Any person seeking to make such a demonstration to us should submit a Petition for Reconsideration to the Office of the Administrator, U.S. Environmental Protection Agency, Room 3000, WJC West Building, 1200 Pennsylvania Ave. NW, Washington, DC 20460, with a copy to both the person(s) listed in the preceding **FOR FURTHER INFORMATION CONTACT** section, and the Associate General Counsel for the Air and Radiation Law Office, Office of General Counsel (Mail Code 2344A), U.S. Environmental Protection Agency, 1200 Pennsylvania Ave. NW, Washington, DC 20460.

II. Executive Summary

A. Purpose of the Regulatory Actions

On November 15, 2021, the EPA published a proposed rule (“November 2021 Proposal”) to mitigate climate-destabilizing pollution and protect human health by reducing greenhouse gas (GHG) and VOC emissions from the oil and natural gas industry,² specifically the Crude Oil and Natural Gas source category.^{3 4} In the November

² The EPA characterizes the oil and natural gas industry operations as being generally composed of four segments: (1) extraction and production of crude oil and natural gas (“oil and natural gas production”), (2) natural gas processing, (3) natural gas transmission and storage, and (4) natural gas distribution.

³ “Standards of Performance for New, Reconstructed, and Modified Sources and Emissions Guidelines for Existing Sources: Oil and Natural Gas Sector Climate Review.” Proposed rule. 86 FR 63110, November 15, 2021.

⁴ The EPA defines the Crude Oil and Natural Gas source category to mean: (1) crude oil production, which includes the well and extends to the point of custody transfer to the crude oil transmission

2021 Proposal, the EPA proposed new standards of performance under section 111(b) of the CAA for GHGs (in the form of methane limitations) and VOC emissions from new, modified, and reconstructed sources in this source category, as well as revisions to standards of performance already codified at 40 CFR part 60, subparts OOOO and OOOOa. The EPA also proposed EG under section 111(d) of the CAA for GHGs emissions (in the form of methane limitations) from existing sources (designated facilities).⁵ The new CAA section 111 NSPS and EG would be codified in 40 CFR part 60 at subpart OOOOb (NSPS OOOOb) and subpart OOOOc (EG OOOOc), respectively. The EPA also proposed several related actions stemming from the joint resolution of Congress, adopted on June 30, 2021, under the CRA disapproving the EPA's final rule titled, "Oil and Natural Gas Sector: Emission Standards for New, Reconstructed, and Modified Sources Review," September 14, 2020 ("2020 Policy Rule"). Lastly, in the November 2021 Proposal the EPA proposed a protocol under the general provisions for OGI.

On December 6, 2022, the EPA published a supplemental proposed rule ("December 2022 Supplemental Proposal") that was composed of two main additions.⁶ First, the EPA updated, strengthened, and expanded on the NSPS OOOOb standards proposed in November 2021 under CAA section 111(b) for GHGs (in the form of methane limitations) and VOC emissions from new, modified, and reconstructed facilities. Second, the EPA updated, strengthened, and expanded the presumptive standards proposed for EG OOOOc in the November 2021 Proposal as part of the CAA section 111(d) EG for GHGs emissions (in the form of methane limitations) from designated facilities. For purposes of EG OOOOc, the EPA also proposed the implementation requirements for state plans developed to limit GHGs pollution (in the form of methane limitations) from designated facilities in the Crude Oil and Natural

Gas source category under CAA section 111(d).

The purpose of this final rulemaking is to finalize these multiple actions to reduce air emissions from the Crude Oil and Natural Gas source category. First, the EPA finalizes NSPS OOOOb regulating GHG (in the form of a limitation on emissions of methane) and VOCs emissions for the Crude Oil and Natural Gas source category pursuant to CAA section 111(b)(1)(B). Second, the EPA finalizes the presumptive standards in EG OOOOc to limit GHGs emissions (in the form of methane limitations) from designated facilities in the Crude Oil and Natural Gas source category, as well as requirements under the CAA section 111(d) for states to follow in developing, submitting, and implementing state plans to establish performance standards. Third, the EPA finalizes several related actions stemming from the joint resolution of Congress, adopted on June 30, 2021, under the CRA, disapproving the 2020 Policy Rule. Fourth, the EPA finalizes a protocol under the general provisions of 40 CFR part 60 for OGI.

These final actions stem from the EPA's authority and obligation under CAA section 111 to directly regulate categories of new stationary sources that cause or contribute to endangerment from air pollution and to promulgate EG for states to follow in regulating existing sources (designated facilities) in the source category. This final rulemaking takes a significant step forward in mitigating climate-destabilizing pollution and protecting human health by reducing GHG and VOC emissions from the oil and natural gas industry, specifically the Crude Oil and Natural Gas source category. These mitigations are based on proven, cost-effective technologies already required by prior EPA regulations or states' regulations or deployed by industry leaders to reduce this dangerous pollution. The final rules will also encourage the deployment of innovative technologies that currently exist to rapidly and cost-effectively detect and reduce methane pollution and promote further innovation that is already under way to find even more efficient and effective ways to mitigate this pollution. Because methane is the main component of natural gas, the rules also result in more saleable product.

The oil and natural gas industry is the United States' largest industrial emitter of methane, a highly potent GHG. Emissions of methane from human activities are responsible for about one-third of the warming due to well-mixed GHGs and constitute the second most important warming agent arising from

human activity after carbon dioxide (CO₂).⁷ According to the Intergovernmental Panel on Climate Change (IPCC), strong, rapid, and sustained methane reductions are critical to reducing near-term disruption of the climate system as well as a vital complement to reductions in other GHGs that are needed to limit the long-term extent of climate change and its destructive impacts. The oil and natural gas industry also emits other harmful pollutants in varying concentrations and amounts, including CO₂, VOC, sulfur dioxide (SO₂), nitrogen oxides (NO_x), hydrogen sulfide (H₂S), carbon disulfide (CS₂), and carbonyl sulfide (COS), as well as benzene, toluene, ethylbenzene, and xylenes (this group is commonly referred to as "BTEX"), and *n*-hexane.

Under the authority of CAA section 111, this rulemaking finalizes comprehensive standards of performance for GHG emissions (in the form of methane limitations) and VOC emissions for new, modified, and reconstructed sources in the Crude Oil and Natural Gas source category, including sources located in the production, processing, and transmission and storage segments. For designated facilities, this rulemaking finalizes EG containing presumptive standards for GHG in the form of methane limitations. States must follow these EG to submit to the EPA plans that establish standards of performance for designated facilities and provide for implementation and enforcement of such standards. The EPA will provide support for states in developing their plans to reduce methane emissions from designated facilities within the Crude Oil and Natural Gas source category. Under the TAR, eligible Tribes may seek approval to implement a plan under CAA section 111(d) in a manner similar to a state. See 40 CFR part 49, subpart A. Tribes may, but are not required to, seek approval for treatment in a manner similar to a state for purposes of developing a TIP implementing the EG codified in 40 CFR part 60, subpart OOOOc. The TAR authorizes Tribes to develop and implement one or more of their own air quality programs, or portions thereof, under the CAA. However, it does not require Tribes to develop a CAA program. Tribes may implement programs that are most relevant to their air quality needs. If a Tribe does not seek and obtain the authority from the EPA to establish a TIP, the EPA has the authority to establish a Federal CAA section 111(d)

pipeline or any other forms of transportation; and (2) natural gas production, processing, transmission, and storage, which include the well and extend to, but do not include, the local distribution company custody transfer station, commonly referred to as the "city-gate."

⁵ The term "designated facility" means "any existing facility which emits a designated pollutant and which would be subject to a standard of performance for that pollutant if the existing facility were an affected facility." See 40 CFR 60.21a(b).

⁶ "Standards of Performance for New, Reconstructed, and Modified Sources and Emissions Guidelines for Existing Sources: Oil and Natural Gas Sector Climate Review." Supplemental notice of proposed rulemaking. 87 FR 74702, December 6, 2022.

⁷ A well-mixed gas is one with an atmospheric lifetime longer than a year or two, which allows the gas to be mixed around the world.

plan for designated facilities that are located in areas of Indian country.⁸ A Federal plan would apply to all designated facilities located in the areas of Indian country covered by the Federal plan unless and until the EPA approves a TIP applicable to those facilities.

The EPA is finalizing these actions in accordance with its legal obligations and authorities following a review directed by Executive Order (E.O.) 13990, "Protecting Public Health and the Environment and Restoring Science to Tackle the Climate Crisis," issued on January 20, 2021. These final actions address the harmful consequences of climate change, which is already resulting in severe and growing human and economic costs within the United States (and globally too). According to the IPCC AR6 assessment, "It is unequivocal that human influence has warmed the atmosphere, ocean and land. Widespread and rapid changes in the atmosphere, ocean, cryosphere and biosphere have occurred." The IPCC AR6 assessment states that these changes have led to increases in heat waves and wildfire weather, reductions in air quality, more intense hurricanes and rainfall events, and rising sea level. These changes, along with future projected changes, endanger the physical survival, health, economic well-being, and quality of life of people living in the United States (U.S.), especially those in the most vulnerable communities.

Methane is both the main component of natural gas and a potent GHG. Using one standard metric (the 100-year global warming potential (GWP), which is a measure of the climate impact of emissions of 1 ton of a GHG over 100 years relative to the impact of the emissions of 1 ton of CO₂ over the same time frame), methane has about 30 times as much climate impact as CO₂. Because methane has a shorter lifetime than CO₂, it has a larger relative impact over shorter time frames, and a smaller one over longer time frames: the IPCC AR6 assessment found that "Over time scales of 10 to 20 years, the global temperature response to a year's worth of current emissions of SLCFs [short lived climate forcers] is at least as large as that due to a year's worth of CO₂ emissions."⁹

⁸ See the EPA website, <https://www.epa.gov/tribal/tribes-approved-treatment-state-tas>, for information on those Tribes that have treatment as a state for specific environmental regulatory programs, administrative functions, and grant programs.

⁹ However, the IPCC AR6 assessment cautioned that "[t]he effects of the SLCFs decay rapidly over the first few decades after pulse emission. Consequently, on time scales longer than about 30

The IPCC estimated that, depending on the reference scenario, collective reductions in these SLCFs (methane, ozone precursors, and hydrofluorocarbons (HFCs)) could reduce warming by 0.2 degrees Celsius (°C) (more than one-third of a degree Fahrenheit (°F) in 2040 and 0.8 °C (almost 1.5 °F) by the end of the century. As methane is the most important SLCF, this makes methane mitigation one of the best opportunities for reducing near-term warming. Emissions from human activities have already more than doubled atmospheric methane concentrations since 1750, and that concentration has been growing larger at record rates in recent years.¹⁰ In the absence of additional reduction policies, methane emissions are projected to continue rising through at least 2040.

Methane's radiative efficiency means that immediate reductions in methane emissions, including from sources in the Crude Oil and Natural Gas source category, can help reduce near-term warming. As natural gas is composed primarily of methane, every natural gas leak or intentional release of natural gas through venting or other processes constitutes a release of methane. Reducing human-caused methane emissions, such as controlling natural gas leaks and releases through the measures in this final action, is critical to addressing climate change and its effects. See section III of this preamble for further discussion on the air emissions from the Crude Oil and Natural Gas source category climate change, including discussion of the impacts of GHGs, VOCs, and SO₂ emissions on public health and welfare.

Methane and VOC emissions from the Crude Oil and Natural Gas source category result from a variety of industry operations across the supply chain. As natural gas moves through the necessarily interconnected system of exploration, production, storage, processing, and transmission that brings it from wellhead to commerce, emissions primarily result from intentional venting, unintentional gas carry-through (*e.g.*, vortexing from

years, the net long-term temperature effects of sectors and regions are dominated by CO₂."

¹⁰ Naik, V., S. Szopa, B. Adhikary, P. Artaxo, T. Berntsen, W.D. Collins, S. Fuzzi, L. Gallardo, A. Kiendler 41 Scharr, Z. Klimont, H. Liao, N. Unger, P. Zanis, 2021, Short-Lived Climate Forcers. In: Climate Change 42 2021: The Physical Science Basis. Contribution of Working Group I to the Sixth Assessment Report of the 43 Intergovernmental Panel on Climate Change [Masson-Delmotte, V., P. Zhai, A. Pirani, S.L. Connors, C. 44 Péan, S. Berger, N. Caud, Y. Chen, L. Goldfarb, M.I. Gomis, M. Huang, K. Leitzell, E. Lonnoy, J.B.R. 45 Matthews, T.K. Maycock, T. Waterfield, O. Yelekçi, R. Yu and B. Zhou (eds.)]. Cambridge University 46 Press.

separator drain, improper liquid level settings, liquid level control valve on an upstream separator or scrubber does not seal properly at the end of an automated liquid dumping event, inefficient separation of gas and liquid phases occurring upstream of tanks allowing some gas carry-through), routine maintenance, unintentional fugitive emissions, flaring, malfunctions, abnormal process conditions, and system upsets. These emissions are associated with a range of specific equipment and practices, including leaking valves, connectors, and other components at well sites and compressor stations; leaks and vented emissions from storage vessels; releases from natural gas-driven pumps and natural gas-driven process controllers; liquids unloading at well sites; and venting or under-performing flaring of associated gas from oil wells. But technical innovations have produced a range of technologies and best practices to monitor, eliminate, or minimize these emissions, which in many cases have the benefit of reducing multiple pollutants at once and recovering saleable product. These technologies and best practices have been deployed by individual oil and natural gas companies, required by state regulations, or reflected in regulations issued by the EPA and other Federal agencies.

In developing this final rulemaking, the EPA applied the latest available information to finalize the analyses presented in the December 2022 Supplemental Proposal. This latest information provided additional insights into lessons learned from states' regulatory efforts, the emission reduction efforts of leading companies, the continued development of new and developing technologies, and information and data from peer-reviewed literature and emission measurement efforts across the U.S.

In both the November 2021 Proposal and the December 2022 Supplemental Proposal, the EPA solicited comment on various aspects of the proposed rules. This final rulemaking responds to the nearly one million total public comments the Agency received. A wide range of stakeholders, including state and local governments, Tribal nations, representatives of the oil and natural gas industry, communities affected by oil and gas pollution, environmental and public health organizations, submitted public comments on both the November 2021 Proposal and the December 2022 Supplemental Proposal. Following the November 2021 Proposal, over 470,000 public comments were submitted. After the December 2022 Supplemental

Proposal, over 515,000 additional public comments were submitted. Many commenters representing diverse perspectives expressed general support for the proposals and requested that the EPA further strengthen the proposed rules and make them more comprehensive. Other commenters highlighted implementation or cost concerns related to elements of both proposals or provided specific data and information that the EPA was able to use to refine or revise several of the proposed standards included in the December 2022 Supplemental Proposal.

This final action also builds on extensive engagement with states, Tribes, and a broad range of stakeholders. The EPA conducted stakeholder trainings after both the November 2021 Proposal and the December 2022 Supplemental Proposal for communities with environmental justice (EJ) concerns, Tribes, and small businesses. The EPA held 3-day virtual public hearings for both the November 2021 Proposal and the December 2022 Supplemental Proposal with over 600 speakers and hundreds of viewers on livestream. Tribal consultations were completed after the November 2021 Proposal at the request of the Northern Arapahoe Tribe, Mandan, Hidatsa and Arikara Nation (MHA Nation), and Eastern Shoshone Tribe.¹¹ Additional Tribal consultation was completed at the request of MHA Nation and an informational meeting was held with the Ute Tribe after the December 2022 Supplemental Proposal.¹² Through this stakeholder engagement, the EPA heard from diverse voices and perspectives, all of which provided ideas and information that helped shape and inform this final rulemaking.

In this final rulemaking, the EPA is finalizing updates to various aspects of the proposed rules because of the information received through the public comment process. For example, after review of the comments, the EPA is finalizing updates to allow owners and operators the option to use advanced methane monitoring technologies for detecting fugitive emissions. All stakeholders supported allowing for the use of alternative technologies and provided the EPA with constructive feedback and information to help finalize this aspect of the rulemaking, along with improvements that provide greater flexibility for owners and operators while ensuring these technologies are used in an effective

way to detect methane emissions. Among other things, the EPA is finalizing changes from the December 2022 Supplemental Proposal that will allow owners and operators to use multiple advanced technologies in combination, and facilitate the use of the best advanced technologies that we know of by streamlining certain of the proposed monitoring requirements associated with their use. The EPA is also finalizing an efficient pathway for demonstrating that new technologies meet the performance requirements established under this rulemaking, and approving their use under this program. The final rulemaking allows for either a periodic screening approach or a continuous monitoring approach. The EPA believes this program will allow owners and operators to leverage advanced technologies that are already available to detect methane emissions rapidly with accuracy, as well as to incorporate promising new technologies that are emerging in this rapidly evolving field.

As a result of information provided through the public comment process, the EPA is also finalizing revisions to the proposed requirements for new sources to limit routine flaring of associated gas. During the comment period, the EPA received extensive information regarding alternatives to routine flaring, state-level requirements to limit or prohibit routine flaring, and commitments that owners and operators have already made voluntarily to phase out routine flaring in the near future. Based on this information and the EPA's updated BSER analysis, the EPA is finalizing requirements that will phase out and eventually prohibit routine flaring of associated gas from newly constructed wells that are developed after the effective date of this rule. These requirements include reasonable exemptions for certain temporary and emergency uses of flaring, and a transition period to allow owners and operators adequate time to incorporate this requirement into their development plans and to deploy any necessary equipment and controls. For a subcategory of existing wells (with documented methane of 40 tons per year (tpy) or less), the EPA is finalizing modifications to its December 2022 Supplemental Proposal to allow routine flaring. This approach reflects information the EPA received during this rulemaking, and the EPA's updated BSER analysis, that indicates that alternatives to routine flaring at such wells are generally costly and could be technically challenging to implement, while achieving relatively small

emission reductions. For higher-emitting existing (above 40 tpy methane), modified, and reconstructed wells, the EPA is finalizing the provisions proposed in the December 2022 Supplemental Proposal limiting routine flaring to situations in which a sales line to collect the associated gas is not available, and the owner and operator has submitted a demonstration that other alternatives to routine flaring are not available due to technical infeasibility. With the updates made in this final rulemaking in response to comments, the EPA believes that the final rules and emission guidelines provide an approach to limiting routine flaring from associated gas that achieves significant reductions in emissions, while also providing owners and operators with flexibility to utilize routine flaring where needed and sufficient lead time to implement alternatives to routine flaring at newly developed wells.

Further, the EPA is finalizing, with certain revisions, requirements proposed in the December 2022 Supplemental Proposal to monitor flares to ensure proper operation and assure continual compliance. Improperly operating flares are a well-documented large source of emissions, and requiring operators to monitor and fix these problems will yield significant methane reductions.

In addition, the EPA is finalizing a Super Emitter Program as part of this rulemaking that requires owners and operators to take appropriate action to investigate very large emissions events upon receiving from the EPA a notification from a certified entity, and if necessary, take steps to ensure compliance with the applicable regulation(s). The EPA has made important modifications to this program based on comments received on the December 2022 Supplemental Proposal. Public comments informed the EPA that there is widespread recognition of the need to address super-emitters, that it is critical for the EPA to have a central role in the program, and that timely information-sharing and response is key to being able to achieve emission reductions. As a result, the final Super Emitter Program provides a central role for the EPA in receiving notifications from certified third parties and verifying that these notifications are complete and have properly documented the existence of a super-emitting event before sending them to the appropriate owner or operator. In addition, as proposed, the EPA will have a central role in approving monitoring technologies, certifying and de-certifying notifiers, requiring that third parties submit

¹¹ See Memorandum in EPA-HQ-OAR-2021-0317.

¹² See Memorandum in EPA-HQ-OAR-2021-0317.

notifications within a limited timeframe, and obligating operators to subsequently respond in a timely manner. These targeted changes for the Super Emitter Program are intended to ensure that the program operates with a high degree of accuracy, integrity, and transparency, while providing owners and operators with prompt and reliable notifications of super-emitting events that may require follow-up investigation and remediation. See sections X and XI of this preamble for a full summary and rationale of the changes since proposal.

After careful consideration of the public comments, the EPA is finalizing other aspects of the rulemaking as proposed. For example, the EPA is finalizing the NSPS and EG for process controllers (formerly referred to as pneumatic controllers) as proposed. For both the NSPS and EG, process controllers are required to meet a methane and VOC emission rate of zero.¹³ Another area of the rulemaking that the EPA is finalizing as proposed is liquids unloading. These sources are required to comply with best management practices for every well that undergoes liquids unloading that results in vented emissions. The EPA is also finalizing standards for well completions and sweetening units as proposed. See sections X and XI of this preamble for a full summary and rationale of the areas of the rulemaking that are being finalized as proposed.

The EPA conducted an analysis of EJ in the development of this final rulemaking and sought to ensure equitable treatment and meaningful involvement of all people regardless of race, color, national origin, or income in the process. The EPA engaged and consulted representatives of frontline communities that are directly affected by and particularly vulnerable to the climate and health impacts of pollution from this source category through interactions such as webinars, listening sessions, and meetings. These opportunities allowed the EPA to hear directly from the public, especially overburdened and underserved communities, on the development of the rulemaking and to factor these concerns into the rulemaking. The extensive pollution reduction measures in this final rulemaking will collectively reduce the emissions of a suite of harmful pollutants and their associated health impacts in communities adjacent to these emission sources. A full discussion and summary of engagement with pertinent stakeholders can be found in section VII of the preamble. A

full discussion of the analysis of EJ is found in section XVI.F of the preamble.

In this final rulemaking, the EPA has conducted a comprehensive analysis of the available data from emission sources in the Crude Oil and Natural Gas source category, the latest available information on control measures and techniques, and information submitted by stakeholders through the public comment process to identify achievable, cost-effective measures to significantly reduce emissions, consistent with the requirements of section 111 of the CAA. This final rulemaking will lead to significant and cost-effective reductions in climate and health-harming pollution and encourage development and deployment of innovative technologies to further reduce this pollution in the Crude Oil and Natural Gas source category.

As described in more detail below, the EPA recognizes that several states and other Federal agencies currently regulate the oil and natural gas industry. The EPA also recognizes that these state and other Federal agency regulatory programs have matured since the EPA began implementing the current NSPS requirements in 2012 and 2016. The EPA further acknowledges the technical innovations that the oil and natural gas industry has made during the past decade; this industry operates at a fast pace and changes constantly as technology evolves. The EPA commends these efforts and recognizes states for their innovative standards, alternative compliance options, and implementation strategies, and these final actions build upon progress made by certain states and Federal agencies in reducing GHG and VOC emissions. See preamble section VI for further discussion of Related State Actions and Other Federal Actions Regulating Oil and Natural Gas Sources and Industry and Voluntary Actions to Address Climate Change.

As the Federal agency with primary responsibility to protect human health and the environment, the EPA has the unique responsibility and authority to regulate harmful air pollutants emitted by the Crude Oil and Natural Gas source category. The EPA recognizes that states and other Federal agencies regulate in accordance with their respective legal authorities and within their respective jurisdictions but collectively do not fully and consistently address the range of sources and emission reduction measures contained in this final rulemaking. Direct Federal regulation of methane from new, reconstructed, and modified sources in this category, combined with approved state plans that are consistent with the EPA's EG

presumptive standards for designated facilities (existing sources), will help reduce both climate- and other health-harming pollution from a large number of sources that are either unregulated or from which additional, cost-effective reductions are available, level the regulatory playing field, and help promote technological innovation.

Included in this final rulemaking are the final new subparts NSPS OOOOb and EG OOOOc and amendatory regulatory text for NSPS OOOO, NSPS OOOOa, and 40 CFR part 60, subpart KKK (NSPS KKK). The public docket for this rulemaking also includes the full text redline versions of NSPS OOOO, NSPS OOOOa, and NSPS KKK amendments.¹⁴ In addition, the EPA is providing a Response to Comments (RTC) document and updated documents including the technical support document (TSD), supporting information collection request (ICR) burden statements, and regulatory impact analysis (RIA) that seeks to account for the full impacts of these proposed actions.

B. Summary of the Major Provisions of This Regulatory Action

This final rulemaking includes four distinct groups of actions under the CAA each of which could have been promulgated as a separate final rule. First, pursuant to CAA section 111(b)(1)(B), the EPA has reviewed, and is finalizing revisions to, the standards of performance for the Crude Oil and Natural Gas source category published in 2012 and 2016 and amended in 2020, codified at 40 CFR part 60, subpart OOOO—“Standards of Performance for Crude Oil and Natural Gas Facilities for Which Construction, Modification, or Reconstruction Commenced After August 23, 2011, and on or Before September 18, 2015” (2012 NSPS) and subpart OOOOa—“Standards of Performance for Crude Oil and Natural Gas Facilities for which Construction, Modification or Reconstruction Commenced After September 18, 2015” (2016 NSPS OOOOa). Specifically, the EPA is updating, strengthening, and expanding the current requirements under CAA section 111(b) for methane and VOC emissions from sources that commenced construction, modification, or reconstruction after December 6, 2022. These final standards of performance will be in a new subpart, 40 CFR part 60, subpart OOOOb (NSPS OOOOb), and include standards for emission sources previously not regulated under the 2012 NSPS OOOO and 2016 NSPS OOOOa.

¹³ See tables 3 and 4 of this preamble for a summary of process controller standards in Alaska.

¹⁴ Docket ID No. EPA-HQ-OAR-2021-0317.

Second, pursuant to CAA section 111(d), the EPA is finalizing the first nationwide EG for states to limit methane pollution from designated facilities in the Crude Oil and Natural Gas source category. The EG being finalized in this rulemaking will be in a new subpart, 40 CFR part 60, subpart OOOOc (EG OOOOc). The EG finalizes presumptive standards for GHG emissions (in the form of methane limitations) from designated facilities that commenced construction, reconstruction, or modification on or before December 6, 2022, and implementation requirements designed to inform states in the development, submittal, and implementation of state plans that are required to establish standards of performance for emissions of GHGs from their designated facilities in the Crude Oil and Natural Gas source category. The EPA is also finalizing regulatory language in NSPS OOOO, NSPS OOOOa, and NSPS KKK to provide clarity on when sources transition from being subject to these NSPS and become subject to a state or Federal plan implementing EG OOOOc.

Third, the EPA is taking several related actions stemming from the joint resolution of Congress, adopted on June 30, 2021, under the CRA, disapproving the EPA's final rule titled, "Oil and Natural Gas Sector: Emission Standards for New, Reconstructed, and Modified Sources Review," 85 FR 57018 (September 14, 2020) ("2020 Policy Rule"). As explained in section XII of this document, the EPA is finalizing amendments to the 2016 NSPS OOOOa to address (1) certain inconsistencies between the VOC and methane standards resulting from the disapproval of the 2020 Policy Rule and (2) certain determinations made in the final rule titled, "Oil and Natural Gas Sector: Emission Standards for New, Reconstructed, and Modified Sources Reconsideration," 85 FR 57398 (September 15, 2020) ("2020 Technical Rule"), specifically with respect to fugitive emissions monitoring at low production well sites and gathering and boosting stations. With respect to the latter, as described below, the EPA is finalizing the rescission of provisions of the 2020 Technical Rule that were not supported by the record for that rule or by our subsequent information and analysis.

In addition, in this final rulemaking the EPA updates the NSPS OOOO and NSPS OOOOa provisions in the CFR to reflect the CRA resolution's disapproval of the final 2020 Policy Rule, specifically, the reinstatement of the NSPS OOOO and NSPS OOOOa requirements that the 2020 Policy Rule

repealed but that came back into effect immediately upon enactment of the CRA resolution. It should be noted that these requirements have come back into effect already, even prior to these updates to CFR text to reflect them.¹⁵ The EPA waited to make these updates to the CFR text until the final rule simply because it was more efficient and clearer to amend the CFR once at the end of this rulemaking process to account for all changes to the 2012 NSPS OOOO (77 FR 49490, August 16, 2012) and 2016 NSPS OOOOa at the same time.

Fourth, the EPA is finalizing a protocol for the use of OGI in leak detection being finalized as appendix K to 40 CFR part 60 (referred to hereafter as appendix K). While this protocol is being finalized in this action, the applicability of the protocol is broader. The protocol is applicable to facilities when specified in a referencing subpart to help determine the presence and location of leaks; it is not currently applicable for use in direct emission rate measurements from sources. The protocol does not on its own apply to any sources. For NSPS OOOOb and EG OOOOc, we are finalizing the use of the protocol for application at natural gas processing plants. The protocol may be applied to other sources only when incorporated through rulemaking to a specific subpart.

Each group of actions just described is severable from the other. In addition, within each group of actions, the requirements governing each emission source are separate from and so severable from the requirements for each other emission source. Specifically, for each emission source, the EPA separately analyzed and determined the appropriate BSER. And for each emission source, the EPA conducted a separate analysis for new sources governed by the NSPS and for existing sources covered by the EG. Each of the requirements in this final rule is functionally independent—*i.e.*, may operate in practice independently of the other standards of performance.

As CAA section 111(a)(1) requires, the standards of performance being finalized in this rulemaking reflect "the degree of emission limitation achievable through the application of the best system of emission reduction [BSER] which (taking into account the cost of achieving such reduction and any nonair quality health and environmental

impact and energy requirement) the Administrator determines has been adequately demonstrated."¹⁶ This rulemaking further finalizes EG for designated facilities, under which states must submit plans which establish standards of performance that reflect the degree of emission limitation achievable through application of the BSER, as identified in the final EG. In this final rulemaking, we evaluated new data made available to the EPA and information provided from public comments on the December 2022 Supplemental Proposal to update the analyses and evaluate whether revisions to the proposed BSER should be considered. For any potential control measure evaluated in this rulemaking, as in the December 2022 Supplemental Proposal, the EPA evaluated the emission reductions achievable through these measures and employed multiple approaches to evaluate the reasonableness of control costs associated with the options under consideration. For example, in evaluating controls for reducing VOC and methane emissions from new sources, we considered a control measure's cost effectiveness under both a "single-pollutant cost effectiveness" approach and a "multipollutant cost effectiveness" approach to appropriately consider that the systems of emission reduction considered in this rulemaking¹⁷ typically achieve reductions in multiple pollutants at once and secure a multiplicity of climate and public health benefits. For both NSPS OOOOb and EG OOOOc, we also compared: (1) the capital costs that would be incurred through compliance with the final standards against the industry's current level of capital expenditures and (2) the annualized costs against the industry's estimated annual revenues. For a detailed discussion of the EPA's consideration of this and other BSER statutory elements, see sections IV and VIII of this

¹⁶The EPA notes that design, equipment, work practice, or operational standards established under CAA section 111(h) (commonly referred to as "work practice standards") reflect the "best technological system of continuous emission reduction" and that this phrasing differs from the "best system of emission reduction" phrase in the definition of "standard of performance" in CAA section 111(a)(1). Although the differences in these phrases may be meaningful in other contexts, for purposes of evaluating the sources and systems of emission reduction at issue in this rulemaking, the EPA has applied these concepts in an essentially comparable manner because the systems of emission reduction the EPA evaluated are all technological.

¹⁷For EG OOOOc, where the pollutant is GHGs in the form of limitations on methane, the EPA considered a control measure's cost effectiveness under a "single-pollutant cost effectiveness" approach.

¹⁵See Congressional Review Act Resolution to Disapprove EPA's 2020 Oil and Gas Policy Rule Questions and Answers (June 30, 2021) available at https://www.epa.gov/system/files/documents/2021-07/qa_cra_for_2020_oil_and_gas_policy_rule.6.30.2021.pdf.

preamble. Table 2 summarizes the applicability dates for the four subparts that the EPA is finalizing.

applicability dates for the four subparts that the EPA is finalizing.

TABLE 2—APPLICABLE DATES FOR SUBPARTS ADDRESSED IN THIS RULEMAKING ¹⁸

Subpart	Source type	Applicable dates
40 CFR part 60, subpart OOOO	New, modified, or reconstructed sources.	After August 23, 2011, and on or before September 18, 2015.
40 CFR part 60, subpart OOOOa	New, modified, or reconstructed sources.	After September 18, 2015, and on or before December 6, 2022.
40 CFR part 60, subpart OOOOb	New, modified, or reconstructed sources.	After December 6, 2022.
40 CFR part 60, subpart OOOOc	Existing sources	On or before December 6, 2022.

1. New Source Performance Standards for New, Modified, and Reconstructed Sources After December 6, 2022 (NSPS OOOOb)

As described in section X of this preamble, the EPA is finalizing several changes to the BSER and the NSPS for certain affected facilities based on a review of new data made available to the EPA and information provided in public comments. For the other NSPS that generally remain unchanged, the EPA is finalizing them as proposed in the November 2021 Proposal and/or December 2022 Supplemental Proposal. The EPA is also finalizing further justifications, flexibilities, or clarifications, as needed, based on the public comments and other additional information received, as described in section X of this preamble. The NSPS applies to affected sources across the Crude Oil and Natural Gas source category, including the production, processing, transmission, and storage segments, for which construction, reconstruction, or modification commenced after December 6, 2022, which is the date of publication of the supplemental proposal for NSPS OOOOb.

In particular, this action finalizes changes to strengthen the proposed VOC and methane standards addressing: fugitive emissions from well sites; monitoring of control devices; super-emitters; storage vessels; associated gas; pumps; equipment leaks at gas plants; appendix K; centrifugal compressors; and reciprocating compressors. It generally leaves unchanged the SO₂ performance standard for sweetening units and the VOC and methane performance standards for well completions, gas well liquids unloading operations, process controllers, and fugitive emissions from compressor stations. A summary of the final BSER

determination and final NSPS for affected sources for which construction, reconstruction, or modification commenced after December 6, 2022 (NSPS OOOOb), is presented in table 2. See sections X and XI of this preamble for a complete discussion of the changes to the BSER determination and NSPS requirements.

The final NSPS OOOOb also includes provisions for the use of advanced methane detection technologies that allow for periodic screening or continuous monitoring for fugitive emissions and emissions from covers and closed vent systems (CVS) used to route emissions to control devices. These advanced methane detection technologies could also be used to identify super-emitter emissions events sooner and outside the normal periodic OGI monitoring for fugitive emissions, control devices, covers on storage vessels, and CVS. Therefore, the EPA is finalizing a Super Emitter Program where an owner or operator must investigate, and if necessary, take steps to ensure compliance with the applicable regulation(s) upon receiving certified notifications of detected emissions that are 100 kilograms per hour (kg/hr) of methane or greater. See section X.C of this preamble for a complete discussion of these final provisions.

2. EG for Sources Constructed Prior to December 6, 2022 (EG OOOOc)

As described in sections X and XI of this preamble, the EPA is finalizing several changes to the BSER determinations and presumptive standards that were proposed under the authority of CAA section 111(d) in the November 2021 Proposal and/or the December 2022 Supplemental Proposal. These changes are based on a review of new data made available to the EPA and information provided in public comments. In the November 2021 Proposal, the EPA proposed the first nationwide EG for GHG (in the form of

methane limitations) for the Crude Oil and Natural Gas source category, including the production, processing, and transmission and storage segments (EG OOOOc). In the December 2022 Supplemental Proposal, the EPA proposed key implementation information unique to the EG for stakeholders.

This action finalizes revisions to strengthen the proposed presumptive standards for methane addressing: fugitive emissions from well sites; monitoring of control devices; super-emitters; storage vessels; associated gas; pumps; equipment leaks at gas plants; appendix K; centrifugal compressors; and reciprocating compressors. It generally leaves unchanged the presumptive standards for gas well liquids unloading operations, process controllers, and fugitive emissions from compressor stations. A summary of the final BSER determination and final presumptive standards for EG OOOOc is presented in table 3. See section X of this preamble for a complete discussion of the changes to the BSER determination and final presumptive standards.

The final EG OOOOc also includes the same provisions described for NSPS OOOOb that allow for the use of alternative test methods using advanced methane detection technologies for periodic screening or continuous monitoring for fugitive emissions and emissions from covers and CVS used to route emissions to control devices. Finally, the EPA is also finalizing in the final EG OOOOc presumptive requirements for state plans to include a Super Emitter Program, where an owner or operator must investigate, and if necessary, take steps to ensure compliance with the applicable regulation(s) upon receiving certified notifications of detected emissions that are 100 kilograms per hour (kg/hr) of methane or greater. See section X of this preamble for a complete discussion of these final provisions.

¹⁸ See preamble section IX, “Interaction of the Rules and Response to Significant Comments Thereon” for discussion on the applicable dates.

As stated in the November 2021 Proposal¹⁹ and the December 2022 Supplemental Proposal,²⁰ when the EPA establishes NSPS for a source category, the EPA is required to issue EG to reduce emissions of certain pollutants from existing sources in that same source category. In such circumstances, under CAA section 111(d), the EPA must issue regulations to establish procedures under which states submit plans to establish, implement, and enforce standards of performance for existing sources for certain air pollutants to which a Federal NSPS would apply if such existing source were a new source. Thus, the issuance of CAA section 111(d) final EG does not impose binding requirements directly on existing sources but instead provides requirements for states in developing their plans. There is a fundamental requirement under CAA section 111(d) that a state's standards of performance in its state plan submittal are no less stringent than the presumptive standard determined by the EPA, which derives from the definition of "standard of performance" in CAA section 111(a)(1). Further, as provided in CAA section 111(d), a state may choose to take into account remaining useful life and other factors (RULOF) in applying a standard of performance to a particular source, consistent with the CAA, the EPA's implementing regulations, and the final EG.

The EPA is finalizing changes to the BSER determinations and the degree of limitation achievable through application of the BSER for certain existing equipment, processes, and activities across the Crude Oil and Natural Gas source category. Those changes are discussed in section X of this preamble. Section XIII of this preamble discusses the components of EG, including the steps, requirements, and considerations associated with the development, submittal, and implementation of state, Tribal, and Federal plans, as appropriate. For the EG, the EPA is translating the degree of emission limitation achievable through application of the BSER (*i.e.*, level of stringency) into presumptive standards that states may use in the development of state plans for specific designated facilities. In doing so, the EPA has

formatted the final EG OOOOc such that if a state chooses to adopt these presumptive standards as the standards of performance in a state plan, the EPA could approve such a plan as meeting the requirements of CAA section 111(d) and the finalized EG, if the plan meets all other applicable requirements. In this way, the presumptive standards included in the final EG OOOOc serve a function similar to that of a model rule,²¹ because they are intended to assist states in developing their plan submissions by providing states with a starting point for standards that are based on general industry parameters and assumptions. The EPA anticipates that providing these presumptive standards will create a streamlined approach for states in developing state plans and for the EPA in evaluating state plans. However, the EPA's action on each state plan submission is carried out via rulemaking, which includes public notice and comment. Inclusion of presumptive standards in the final EG does not predetermine the outcomes of any future rulemaking on state plan submittals.

Designated facilities located in Indian country would not be encompassed within a state's CAA section 111(d) plan. Instead, an eligible Tribe that has one or more designated facilities located in its area of Indian country would have the opportunity, but not the obligation, to seek authority and submit a plan that establishes standards of performance for those facilities on its Tribal lands. If a Tribe does not submit a plan, or if the EPA does not approve a Tribe's plan, then the EPA has the authority to establish a Federal plan for designated facilities located within that Tribe's area of Indian country. A summary of the final EG for existing sources (EG OOOOc) for the oil and natural gas sector is presented in table 4. See section X of this preamble for a complete discussion of the final EG requirements.

3. Final Amendments to 2016 NSPS OOOOa, and CRA-Related CFR Updates

The EPA is finalizing modifications to the 2016 NSPS OOOOa to address

²¹ The presumptive standards are not the same as a Federal plan under CAA section 111(d)(2). The EPA has an obligation to promulgate a Federal plan if a state fails to submit a satisfactory plan. In such circumstances, the final EG and presumptive standards would serve as a guide to the development of a Federal plan. See section XIII.F of this document for information on Federal plans.

certain amendments to the VOC standards for sources in the production and processing segments finalized in the 2020 Technical Rule. Because the methane standards for the production and processing segments and all standards for the transmission and storage segment were removed from the 2016 NSPS OOOOa via the 2020 Policy Rule prior to the finalization of the 2020 Technical Rule, the latter amendments apply only to the 2016 NSPS OOOOa VOC standards for the production and processing segments. In this final rulemaking, the EPA also is applying some of the 2020 Technical Rule amendments to the methane standards for all industry segments and to VOC standards for the transmission and storage segment in the 2016 NSPS OOOOa. These amendments are associated with the requirements for well completions, pumps, closed vent systems, fugitive emissions, alternative means of emission limitation (AMELs), and onshore natural gas processing plants, as well as other technical clarifications and corrections. The EPA is also finalizing a repeal of the amendments in the 2020 Technical Rule that (1) exempted low production well sites from monitoring fugitive emissions and (2) changed monitoring of VOC emissions at gathering and boosting compressor stations from quarterly to semiannual, which currently applies only to VOC standards (not methane standards) from the production and processing segments. A summary of the final amendments to the 2016 OOOOa NSPS is presented in section XII of this preamble.

Lastly, in this rulemaking, the EPA updates the NSPS OOOO and OOOOa provisions in the CFR to reflect the CRA resolution's disapproval of the final 2020 Policy Rule, specifically, the reinstatement of the NSPS OOOO and OOOOa requirements that the 2020 Policy Rule repealed but that came back into effect immediately upon enactment of the CRA resolution. The EPA waited to make the updates to the CFR text until the final rulemaking because it would be more efficient and clearer to amend the CFR once at the end of this rulemaking process to account for all changes to the 2012 NSPS OOOO and 2016 NSPS OOOOa at the same time, rather than make piecemeal amendments to the CFR.

¹⁹ See 86 FR 63117 (November 15, 2021).

²⁰ See 87 FR 74702 (December 6, 2022).

TABLE 3—SUMMARY OF FINAL BSER AND FINAL NEW SOURCE PERFORMANCE STANDARDS FOR GHGS AND VOCs (NSPS OOOOb)²²

Affected source	Final BSER	Final new source performance standards for GHGs and VOCs
Fugitive Emissions: Single Wellhead Only Well Sites and Small Well Sites.	Quarterly AVO monitoring surveys	<p>Quarterly AVO surveys. First attempt at repair within 15 days after detecting fugitive emissions. Final repair within 15 days after first attempt.</p> <p>Fugitive monitoring continues for all well sites until the site has been closed, including plugging the wells at the site and submitting a well closure report.</p>
Fugitive Emissions: Multi-wellhead Only Well Sites (2 or more wellheads).	<p>Quarterly AVO monitoring surveys</p> <p>AND</p> <p>Monitoring and repair based on semiannual monitoring using OGI².</p>	<p>Quarterly AVO surveys. First attempt at repair within 15 days after detecting fugitive emissions. Final repair within 15 days after first attempt.</p> <p>Semiannual OGI monitoring (Optional semiannual EPA Method 21 monitoring with 500 ppm defined as a leak).</p> <p>First attempt at repair within 30 days after detecting fugitive emissions. Final repair within 30 days after first attempt.</p> <p>Fugitive monitoring continues for all well sites until the site has been closed, including plugging the wells at the site and submitting a well closure report.</p>
Fugitive Emissions: Well Sites with Major Production and Processing Equipment and Centralized Production Facilities.	<p>Bimonthly AVO monitoring surveys (<i>i.e.</i>, every other month).</p> <p>AND</p> <p>Monitoring and repair based on quarterly monitoring using OGI.</p>	<p>Bimonthly AVO surveys. First attempt at repair within 15 days after detecting fugitive emissions. Final repair within 15 days after first attempt.</p> <p>AND</p> <p>Well sites with specified major production and processing equipment: Quarterly OGI monitoring. (Optional quarterly EPA Method 21 monitoring with 500 ppm defined as a leak).</p> <p>First attempt at repair within 30 days after detecting fugitive emissions. Final repair within 30 days after first attempt.</p> <p>Fugitive monitoring continues for all well sites until the site has been closed, including plugging the wells at the site and submitting a well closure report.</p>
Fugitive Emissions: Compressor Stations	<p>Monthly AVO monitoring surveys</p> <p>AND</p> <p>Monitoring and repair based on quarterly monitoring using OGI.</p>	<p>Monthly AVO surveys. First attempt at repair within 15 days after detecting fugitive emissions. Final repair within 15 days after first attempt.</p> <p>AND</p> <p>Quarterly OGI monitoring. (Optional quarterly EPA Method 21 monitoring with 500 ppm defined as a leak).</p> <p>First attempt at repair within 30 days after detecting fugitive emissions. Final repair within 30 days after first attempt.</p>
Fugitive Emissions: Well Sites and Compressor Stations on Alaska North Slope.	Monitoring and repair based on annual monitoring using OGI.	<p>Annual OGI monitoring. (Optional annual EPA Method 21 monitoring with 500 ppm defined as a leak).</p> <p>First attempt at repair within 30 days after detecting fugitive emissions. Final repair within 30 days after first attempt.</p>
Storage Vessels: A Single Storage Vessel or Tank Battery with PTE ⁴ of 6 tpy or more of VOC or PTE of 20 tpy or more of methane.	Capture and route to a control device	95 percent reduction of VOC and methane.
Process Controllers: Natural Gas-driven	Use of zero-emissions controllers	VOC and GHG (methane) emission rate of zero.
Process Controllers: Alaska (at sites where on-site power is not available—continuous bleed natural gas-driven).	Use of low-bleed process controllers	Natural gas bleed rate no greater than 6 scfh. ⁵
Process Controllers: Alaska (at sites where on-site power is not available—intermittent natural gas-driven).	Monitor and repair through fugitive emissions program.	OGI monitoring and repair of emissions from controller malfunctions.

TABLE 3—SUMMARY OF FINAL BSER AND FINAL NEW SOURCE PERFORMANCE STANDARDS FOR GHGS AND VOCs (NSPS OOOOb)²²—Continued

Affected source	Final BSER	Final new source performance standards for GHGs and VOCs
Well Liquids Unloading	Best management practices to minimize or eliminate methane and VOC emissions to the maximum extent possible.	Perform best management practices to minimize or eliminate methane and VOC emissions to the maximum extent possible from liquids unloading events that vent emissions to the atmosphere.
Wet Seal Centrifugal Compressors (except for those located at well sites).	Capture and route emissions from the wet seal fluid degassing system to a control device.	95 percent reduction of methane and VOC emissions.
Wet Seal Centrifugal Compressors (except for those located at well sites): Self-contained centrifugal compressors and wet seal compressors equipped with a mechanical seal.	(Optional) Monitoring and repair to maintain volumetric flow rate at or below 3 scfm.	Monitoring and repair to maintain volumetric flow rate at or below 3 scfm per compressor seal.
Wet Seal Centrifugal Compressors (except for those located at well sites): Alaska North Slope centrifugal compressors equipped with a seal oil recovery system.	(Optional) Monitoring and repair to maintain volumetric flow rate at or below 9 scfm per seal.	Monitoring and repair to maintain volumetric flow rate at or below 9 scfm per compressor seal.
Dry Seal Centrifugal Compressors (except for those located at well sites).	Monitoring and repair to maintain volumetric flow rate at or below 10 scfm ⁷ per seal.	Monitoring and repair of seal to maintain volumetric flow rate at or below 10 scfm per compressor seal.
Reciprocating Compressors (except for those located at well sites).	Monitoring and repair or replace the reciprocating compressor rod packing in order to maintain volumetric flow rate at or below 2 scfm per cylinder.	Monitoring and repair or replacement of rod packing to maintain volumetric flow rate at or below 2 scfm per cylinder.
Pumps: Natural gas-driven	Use of zero-emissions pumps	GHG (methane) and VOC emission rate of zero.
Pumps: Natural gas-driven (at sites where on-site power is not available and there are fewer than 3 diaphragm pumps).	Use of an existing VRU or control device	Route pump emissions to a process if VRU is onsite, or to control device if onsite.
Well Completions: Subcategory 1 (non-wildcat and non-delineation wells).	Combination of REC ⁸ and the use of a completion combustion device.	<p>Applies to each well completion operation with hydraulic fracturing.</p> <p>REC in combination with a completion combustion device; venting in lieu of combustion where combustion would present demonstrable safety hazards.</p> <p>Initial flowback stage: Route to a storage vessel or completion vessel (frac tank, lined pit, or other vessel) and separator.</p> <p>Separation flowback stage: Route all salable gas from the separator to a flow line or collection system, reinject the gas into the well or another well, use the gas as an onsite fuel source or use for another useful purpose that a purchased fuel or raw material would serve. If technically infeasible to route recovered gas as specified, recovered gas must be combusted. All liquids must be routed to a storage vessel or well completion vessel, collection system, or be re-injected into the well or another well.</p> <p>The operator is required to have (and use) a separator onsite during the entire flowback period.</p>

TABLE 3—SUMMARY OF FINAL BSER AND FINAL NEW SOURCE PERFORMANCE STANDARDS FOR GHGS AND VOCs (NSPS OOOOb)²²—Continued

Affected source	Final BSER	Final new source performance standards for GHGs and VOCs
Well Completions: Subcategory 2 (exploratory, wildcat, and delineation wells and non-wildcat and non-delineation low-pressure wells).	Use of a completion combustion device	<p>Applies to each well completion operation with hydraulic fracturing.</p> <p>The operator is not required to have a separator onsite. Either: (1) Route all flowback to a completion combustion device with a continuous pilot flame; or (2) Route all flowback into one or more well completion vessels and commence operation of a separator unless it is technically infeasible for a separator to function. Any gas present in the flowback before the separator can function is not subject to control under this section. Capture and direct recovered gas to a completion combustion device with a continuous pilot flame.</p> <p>For both options (1) and (2), combustion is not required in conditions that may result in a fire hazard or explosion, or where high heat emissions from a completion combustion device may negatively impact tundra, permafrost, or waterways.</p>
Equipment Leaks at Natural Gas Processing Plants.	LDAR ⁹ with bimonthly OGI	LDAR with OGI following procedures in appendix K.
New Wells with Associated Gas that commenced construction after May 7, 2026.	Route associated gas to a sales line	Route associated gas to a sales line; or, the gas can be used for another useful purpose that a purchased fuel, chemical feedstock, or raw material would serve, or recovered from the separator and reinjected into the well or injected into another well.
New wells with Associated Gas that commenced construction between May 7, 2024, and May 7, 2026.	Route associated gas to a sales line	Route associated gas to a sales line; or, the gas can be used for another useful purpose that a purchased fuel, chemical feedstock, or raw material would serve, or recovered from the separator and reinjected into the well or injected into another well. If demonstrated, and documented annually, that routing to a sales line and the alternatives are not technically feasible, the associated gas can be routed to a flare or other control device that achieves at least 95 percent reduction in GHG (methane) and VOC emissions. A second infeasibility determination may not extend beyond 24 months from effective date.
New Wells with Associated Gas that Commenced Construction after December 6, 2022, and before May 7, 2024.	Route associated gas to a sales line	Route associated gas to a sales line; or, the gas can be used for another useful purpose that a purchased fuel, chemical feedstock, or raw material would serve, or recovered from the separator and reinjected into the well or injected into another well. If demonstrated, and documented annually, that routing to a sales line and the alternatives are not technically feasible, the associated gas can be routed to a flare or other control device that achieves at least 95 percent reduction in GHG (methane) and VOC emissions.

TABLE 3—SUMMARY OF FINAL BSER AND FINAL NEW SOURCE PERFORMANCE STANDARDS FOR GHGS AND VOCs (NSPS OOOOb)²²—Continued

Affected source	Final BSER	Final new source performance standards for GHGs and VOCs
Wells with Associated Gas Reconstructed or Modified after December 6, 2022.	Route associated gas to a sales line	Route associated gas to a sales line; or, the gas can be used for another useful purpose that a purchased fuel, chemical feedstock, or raw material would serve, or recovered from the separator and reinjected into the well or injected into another well. If demonstrated, and documented annually, that routing to a sales line and the alternatives are not technically feasible, the associated gas can be routed to a flare or other control device that achieves at least 95 percent reduction in GHG (methane) and VOC emissions.
Sweetening Units	Achieve SO ₂ emission reduction efficiency	Achieve required minimum SO ₂ emission reduction efficiency.

- ¹ tpy (tons per year).
- ² OGI (optical gas imaging).
- ³ ppm (parts per million).
- ⁴ PTE (potential to emit).
- ⁵ scfh (standard cubic feet per hour).
- ⁶ BMP (best management practices).
- ⁷ scfm (standard cubic feet per minute).
- ⁸ REC (reduced emissions completion).
- ⁹ LDAR (leak detection and repair).

TABLE 4—SUMMARY OF FINAL BSER AND FINAL PRESUMPTIVE STANDARDS FOR GHGS FROM DESIGNATED FACILITIES (EG OOOOc)²³

Designated facility	Final BSER	Final presumptive standards for GHGs
Fugitive Emissions: Single Wellhead Only Well Sites and Small Well Sites.	Quarterly AVO monitoring surveys	Quarterly AVO surveys. First attempt at repair within 15 days after detecting fugitive emissions. Final repair within 15 days after first attempt. Fugitive monitoring continues for all well sites until the site has been closed, including plugging the wells at the site and submitting a well closure report.
Fugitive Emissions: Multi-wellhead Only Well Sites (2 or more wellheads).	Quarterly AVO monitoring surveys AND Monitoring and repair based on semiannual monitoring using OGI ² .	Quarterly AVO surveys. First attempt at repair within 15 days after detecting fugitive emissions. Final repair within 15 days after first attempt. Semiannual OGI monitoring (Optional semi-annual EPA Method 21 monitoring with 500 ppm defined as a leak). First attempt at repair within 30 days after detecting fugitive emissions. Final repair within 30 days after first attempt. Fugitive monitoring continues for all well sites until the site has been closed, including plugging the wells at the site and submitting a well closure report.
Fugitive Emissions: Well Sites and Centralized Production Facilities.	Bimonthly AVO monitoring surveys (<i>i.e.</i> , every other month). AND Monitoring and repair based on quarterly monitoring using OGI.	Bimonthly AVO surveys. First attempt at repair within 15 days after detecting fugitive emissions. Final repair within 15 days after first attempt. AND Well sites with specified major production and processing equipment: Quarterly OGI monitoring. (Optional quarterly EPA Method 21 monitoring with 500 ppm defined as a leak).

²² For fugitive emissions at well sites, centralized production facilities, and compressor stations, the

EPA is finalizing an advanced measurement technology compliance option to use alternative

periodic screening and alternative continuous monitoring instead of OGI and AVO monitoring.

TABLE 4—SUMMARY OF FINAL BSER AND FINAL PRESUMPTIVE STANDARDS FOR GHGS FROM DESIGNATED FACILITIES (EG OOOOc) ²³—Continued

Designated facility	Final BSER	Final presumptive standards for GHGs
Fugitive Emissions: Compressor Stations	Monthly AVO monitoring surveys	First attempt at repair within 30 days after finding fugitive emissions. Final repair within 30 days after first attempt. Fugitive monitoring continues for all well sites until the site has been closed, including plugging the wells at the site and submitting a well closure report.
Fugitive Emissions: Well Sites and Compressor Stations on Alaska North Slope.	AND Monitoring and repair based on quarterly monitoring using OGI.	Monthly AVO surveys. First attempt at repair within 15 days after detecting fugitive emissions. Final repair within 15 days after first attempt. AND Quarterly OGI monitoring. (Optional quarterly EPA Method 21 monitoring with 500 ppm defined as a leak). First attempt at repair within 30 days after detecting fugitive emissions. Final repair within 30 days after first attempt.
Storage Vessels: Tank Battery with PTE of 20 tpy or More of Methane.	Capture and route to a control device	Annual OGI monitoring. (Optional annual EPA Method 21 monitoring with 500 ppm defined as a leak). First attempt at repair within 30 days after finding fugitive emissions. Final repair within 30 days after first attempt. 95 percent reduction of methane.
Process Controllers: Natural gas-driven	Use of zero-emissions controllers	GHG (methane) emission rate of zero.
Process Controllers: Alaska (at sites where on-site power is not available—continuous bleed natural gas-driven).	Use of low-bleed process controllers	Natural gas bleed rate no greater than 6 scfh.
Process Controllers: Alaska (at sites where on-site power is not available—intermittent natural gas-driven).	Monitor and repair through fugitive emissions program.	OGI monitoring and repair of emissions from controller malfunctions.
Gas Well Liquids Unloading	Best management practices to minimize or eliminate methane and VOC emissions to the maximum extent possible.	Perform best management practices to minimize or eliminate methane and VOC emissions to the maximum extent possible from liquids unloading events that vent emissions to the atmosphere.
Wet Seal Centrifugal Compressors (except for those located at well sites).	Monitoring and repair to maintain volumetric flow rate at or below 3 scfm ⁷ .	Monitoring and repair to maintain volumetric flow rate at or below 3 scfm per seal.
Wet Seal Centrifugal Compressors (except for those located at well sites): Self-contained centrifugal compressors and wet seal compressors equipped with a mechanical seal.	Monitoring and repair to maintain volumetric flow rate at or below 3 scfm.	Monitoring and repair to maintain volumetric flow rate at or below 3 scfm per seal.
Wet Seal Centrifugal Compressors (except for those located at well sites): Alaska North Slope centrifugal compressors equipped with a seal oil recovery system.	Monitoring and repair to maintain volumetric flow rate at or below 9 scfm.	Monitoring and repair to maintain volumetric flow rate at or below 9 scfm per seal.
Dry Seal Centrifugal Compressors (except for those located at well sites).	Monitoring and repair to maintain volumetric flow rate at or below 10 scfm ⁷ .	Monitoring and repair to maintain volumetric flow rate at or below 10 scfm per seal.
Reciprocating Compressors (except for those located at well sites).	Monitoring and repair or replace the reciprocating compressor rod packing in order to maintain volumetric flow rate at or below 2 scfm.	Monitoring and repair to maintain volumetric flow rate at or below 2 scfm per cylinder.
Pumps: Natural gas-driven	Use of zero-emissions pumps	GHG (methane) emission rate of zero.
Pumps: Natural gas-driven (at sites where on-site power is not available and there are fewer than 3 diaphragm pumps).	Use of an existing VRU or control device	Route pump emissions to a process if VRU is onsite, or to control device if onsite.
Equipment Leaks at Natural Gas Processing Plants.	LDAR with bimonthly OGI	LDAR with OGI following procedures in appendix K.

TABLE 4—SUMMARY OF FINAL BSER AND FINAL PRESUMPTIVE STANDARDS FOR GHGs FROM DESIGNATED FACILITIES (EG OOOOc)²³—Continued

Designated facility	Final BSER	Final presumptive standards for GHGs
Wells with Associated Gas greater than 40 tpy methane.	Route associated gas to a sales line	Route associated gas to a sales line. Alternatively, the gas can be used as an onsite fuel source or used for another useful purpose that a purchased fuel or raw material would serve, or be injected into the well or another well. If demonstrated, and annually documented, that a sales line and alternatives are not technically feasible, the gas can be routed to a flare or other control device that achieves at least 95 percent reduction in methane emissions.
Wells with Associated Gas 40 tpy methane or less.	Route associated gas to a flare or other control device that achieves at least 95 percent reduction in methane emissions.	Route associated gas to a sales line. Alternatively, the gas can be used as an onsite fuel source or used for another useful purpose that a purchased fuel or raw material would serve, or be injected into the well or another well. Alternatively, the gas can be routed to a flare or other control device that achieves at least 95 percent reduction in methane emissions.

C. Costs and Benefits

In accordance with the requirements of E.O. 12866, the EPA projected the emissions reductions, costs, and benefits that may result from this final rulemaking. These results are presented in detail in the RIA accompanying this final rulemaking developed in response to E.O. 12866. The RIA focuses on the elements of the final rules that are likely to result in quantifiable cost or emissions changes compared to a baseline without the rule. We estimated the cost, emissions, and benefit impacts for the 2024 to 2038 period. We present the present value (PV) and equivalent annual value (EAV) of costs, benefits, and net benefits of this rulemaking in 2019 dollars.

The initial analysis year in the RIA is 2024 as we assume the NSPS rules will take effect early in 2024. The EG will take longer to go into effect as states will need to develop implementation plans in response to the EG and have them approved by the EPA. We assume in the RIA that this process will take 4 years, and so EG impacts will begin in 2028. The final analysis year is 2038, which allows us to provide up to 15 years of projected impacts after the NSPS is assumed to take effect and 11 years of projected impacts after the EG is assumed to take effect.

The cost analysis presented in the RIA reflects a nationwide engineering analysis of compliance cost and

emissions reductions, of which there are two main components. The first component is a set of representative or model plants for each regulated facility, segment, and control option. The characteristics of the model plant include typical equipment, operating characteristics, and representative factors including baseline emissions and the costs, emissions reductions, and product recovery resulting from each control option. The second component is a set of projections of activity data for affected facilities, distinguished by vintage, year, and other necessary attributes (e.g., oil versus natural gas wells). Impacts are calculated by setting parameters on how and when affected facilities are assumed to respond to a particular regulatory regime, multiplying activity data by model plant cost and emissions estimates, differencing from the baseline scenario, and then summing to the desired level of aggregation. In addition to emissions reductions, some control options result in natural gas recovery, which can then be combusted in production or sold. Where applicable, we present projected compliance costs with and without the projected revenues from product recovery.

The EPA expects climate and health benefits due to the emissions reductions projected under this final rulemaking. The EPA estimated the monetized climate benefits of methane emission reductions expected from these final rules using estimates of the social cost of methane (SC-CH₄) that reflect recent advances in the scientific literature on climate change and its economic impacts and incorporate

recommendations made by the National Academies of Science, Engineering, and Medicine (National Academies 2017). The EPA presented these estimates in a sensitivity analysis in the December 2022 RIA, solicited public comment on the methodology and use of these estimates, and has conducted an external peer review of these estimates, as discussed in section XVI.E of this preamble.

In addition to climate benefits from methane emissions reductions, the EPA expects that VOC emission reductions under the final rulemaking will improve air quality and improve health and welfare due to reduced exposure to ozone, particulate matter with a diameter of 2.5 micrometers or less (PM_{2.5}), and hazardous air pollutants (HAP). In a national-level analysis of public health impacts, the EPA used the environmental Benefits Mapping and Analysis Program—Community Edition (BenMAP-CE) software program to quantify counts of premature deaths and illnesses attributable to photochemical modeled changes in summer season average ozone concentrations resulting from projected VOC emissions reductions under the rulemaking. The methods for quantifying the number and value of air pollution-attributable premature deaths and illnesses are described in the RIA for this action and the TSD titled *Estimating PM_{2.5}- and Ozone-Attributable Health Benefits*.²⁴ These reductions in health-harming pollution would result in significant public health benefits including avoided

²³ For fugitive emissions at well sites, centralized production facilities, and compressor stations, the EPA is finalizing an advanced measurement technology compliance option to use alternative periodic screening and alternative continuous monitoring instead of OGI and AVO monitoring.

²⁴ https://www.epa.gov/system/files/documents/2023-01/Estimating%20PM2.5-%20and%20Ozone-Attributable%20Health%20Benefits%20TSD_0.pdf.

premature deaths, reductions in new asthma cases and incidences of asthma symptoms, reductions in hospital admissions and emergency department visits, and reductions in lost school days.

The EPA notes that the benefits analysis is distinct from the statutory BSEER determinations finalized herein, which are based on the statutory factors the EPA is required to consider under

section 111(a) of the CAA (including cost, energy requirements and nonair quality health, and environmental impacts). The assessment of benefits described above and in the RIA is presented solely for the purposes of complying with E.O. 12866 and providing the public with a complete depiction of the impacts of the rulemaking.

The projected national-level emissions reductions over the 2024 to 2038 period anticipated under the finalized requirements are presented in table 5. Table 6 presents the PV and EAV of the projected benefits, costs, and net benefits over the 2024 to 2038 period under the final rule using discount rates of 2, 3, and 7 percent.

TABLE 5—PROJECTED EMISSIONS REDUCTIONS UNDER THE FINAL RULES, 2024–2038 TOTAL

Pollutant	Emissions reductions (2024–2038 total)
Methane (million short tons) ^a	58
VOC (million short tons)	16
Hazardous Air Pollutant (million short tons)	0.59
Methane (million metric tons CO ₂ Eq.) ^b	1,500

^a To convert from short tons to metric tons, multiply the short tons by 0.907. Alternatively, to convert metric tons to short tons, multiply metric tons by 1.102.

^b Carbon dioxide equivalent (CO₂ Eq.) calculated using a global warming potential of 28.

TABLE 6—BENEFITS, COSTS, NET BENEFITS, AND EMISSIONS REDUCTIONS UNDER THE FINAL RULES, 2024–2038

[Dollar Estimates in Millions of 2019 Dollars] ^a

	2 Percent near-term Ramsey discount rate					
	PV	EAV	PV	EAV	PV	EAV
Climate Benefits ^b	\$110,000	\$8,500	\$110,000	\$8,500	\$110,000	\$8,500
	2 Percent discount rate		3 Percent discount rate		7 Percent discount rate	
	PV	EAV	PV	EAV	PV	EAV
Ozone Health Benefits ^c	\$7,000	\$540	\$6,100	\$510	\$3,500	\$380
Net Compliance Costs	19,000	1,500	18,000	1,500	14,000	1,600
Compliance Costs	31,000	2,400	29,000	2,400	22,000	2,400
Value of Product Recovery	13,000	980	11,000	950	7,400	820
Net Benefits ^d	97,000	7,600	97,000	7,500	98,000	7,300
Non-Monetized Benefits	Climate and ozone-related health benefits from reducing 58 million short tons of methane from 2024 to 2038. Benefits to provision of ecosystem services associated with reduced ozone concentrations from reducing 16 million short tons of VOC from 2024 to 2038. PM _{2.5} -related health benefits from reducing 16 million short tons of VOC from 2024 to 2038. HAP benefits from reducing 590 thousand short tons of HAP from 2024 to 2038.					

^a Values rounded to two significant figures. Totals may not appear to add correctly due to rounding.

^b Climate benefits are based on reductions in methane emissions and are calculated using three different estimates of the SC-CH₄ (under 1.5 percent, 2.0 percent, and 2.5 percent near-term Ramsey discount rates). For the presentational purposes of this table, we show the climate benefits associated with the SC-CH₄ at the 2 percent near-term Ramsey discount rate. Please see tables 3.4 and 3.5 in the RIA for the full range of monetized climate benefit estimates. All net benefits are calculated using climate benefits discounted at the 2 percent near-term rate.

^c Monetized benefits include those related to public health associated with reductions in ozone concentrations. The health benefits are associated with several point estimates.

^d Several categories of climate, human health, and welfare benefits from methane, VOC, and HAP emissions reductions remain unmonetized and are thus not directly reflected in the quantified benefit estimates in the table.

III. Air Emissions From the Crude Oil and Natural Gas Sector and Public Health and Welfare

A. Impacts of GHGs, VOCs, and SO₂ Emissions on Public Health and Welfare

As noted previously, the oil and natural gas industry emits a wide range of pollutants, including GHGs (such as methane and CO₂), VOCs, SO₂, NO_x, H₂S, CS₂, and COS. See 49 FR 2636,

2637 (January 20, 1984). As noted below, to this point the EPA has focused its regulatory efforts under CAA section 111 on GHGs, VOC, and SO₂.²⁵

²⁵ We note that the EPA’s focus on GHGs (in particular methane), VOC, and SO₂ in these analyses does not in any way limit the EPA’s authority to promulgate standards that would apply to other pollutants emitted from the Crude Oil and Natural Gas source category, if the EPA determines in the future that such action is appropriate.

1. Climate Change Impacts From GHGs Emissions

Elevated concentrations of GHGs are and have been warming the planet, leading to changes in the Earth’s climate including changes in the frequency and intensity of heat waves, precipitation, and extreme weather events; rising seas; and retreating snow and ice. The changes taking place in the atmosphere as a result of the well-documented

buildup of GHGs due to human activities are changing the climate at a pace and in a way that threatens human health, society, and the natural environment. Human-produced GHGs, largely derived from our reliance on fossil fuels, are causing serious and life-threatening environmental and health impacts. While the EPA is not making any new scientific or factual findings with regard to the well-documented impact of GHG emissions on public health and welfare in support of this rulemaking, the EPA is providing some scientific background on climate change to offer additional context for this rulemaking and to increase the public's understanding of the environmental impacts of GHGs.

Extensive additional information on climate change is available in the scientific assessments and the EPA documents that are briefly described in this section of this preamble, as well as in the technical and scientific information supporting them. One of those documents is the EPA's 2009 *Endangerment and Cause or Contribute Findings for GHGs Under Section 202(a)* of the CAA (74 FR 66496, December 15, 2009).²⁶ In the 2009 Endangerment Findings, the Administrator found under section 202(a) of the CAA that elevated atmospheric concentrations of six key well-mixed GHGs—CO₂, methane, N₂O, HFCs, perfluorocarbons (PFCs), and sulfur hexafluoride (SF₆)—“may reasonably be anticipated to endanger the public health and welfare of current and future generations” (74 FR 66523, December 15, 2009), and the science and observed changes since that time have confirmed and strengthened the understanding and concerns regarding the climate risks considered in the Findings. The 2009 Endangerment Findings, together with the extensive scientific and technical evidence in the supporting record, documented that climate change caused by human emissions of GHGs threatens the public health of the U.S. population. It explained that by raising average temperatures, climate change increases the likelihood of heat waves, which are associated with increased deaths and

illnesses (74 FR 66497, December 15, 2009). While climate change also increases the likelihood of reductions in cold-related mortality, evidence indicates that the increases in heat mortality will be larger than the decreases in cold mortality in the U.S. (74 FR 66525, December 15, 2009). The 2009 Endangerment Findings further explained that compared to a future without climate change, climate change is expected to increase tropospheric ozone pollution over broad areas of the U.S., including in the largest metropolitan areas with the worst tropospheric ozone problems, and thereby increase the risk of adverse effects on public health (74 FR 66525, December 15, 2009). Climate change is also expected to cause more intense hurricanes, and more frequent and intense storms of other types, and heavy precipitation, with impacts on other areas of public health such as the potential for increased deaths, injuries, infectious and waterborne diseases, and stress-related disorders (74 FR 66525, December 15, 2009). Children, the elderly, and the poor are among the most vulnerable to these climate-related health effects (74 FR 66498, December 15, 2009).

The 2009 Endangerment Findings also documented, together with the extensive scientific and technical evidence in the supporting record, that climate change touches nearly every aspect of public welfare²⁷ in the U.S. with resulting economic costs, including: changes in water supply and quality due to increased frequency of drought and extreme rainfall events; increased risk of storm surge and flooding in coastal areas and land loss due to inundation; increases in peak electricity demand and risks to electricity infrastructure; and the potential for significant agricultural disruptions and crop failures (though

²⁷ The CAA states in section 302(h) that “[a]ll language referring to effects on welfare includes, but is not limited to, effects on soils, water, crops, vegetation, manmade materials, animals, wildlife, weather, visibility, and climate, damage to and deterioration of property, and hazards to transportation, as well as effects on economic values and on personal comfort and well-being, whether caused by transformation, conversion, or combination with other air pollutants.” 42 U.S.C. 7602(h).

offset to some extent by carbon fertilization). These impacts are also global and may exacerbate problems outside the U.S. that raise humanitarian, trade, and national security issues for the U.S. (74 FR 66530, December 15, 2009).

In 2016, the Administrator similarly issued Endangerment and Cause or Contribute Findings for GHG emissions from aircraft under section 231(a)(2)(A) of the CAA (81 FR 54422, August 15, 2016).²⁸ In the 2016 Endangerment Findings, the Administrator found that the body of scientific evidence amassed in the record for the 2009 Endangerment Findings compellingly supported a similar endangerment finding under CAA section 231(a)(2)(A) and also found that the science assessments released between the 2009 and the 2016 Findings “strengthen and further support the judgment that GHGs in the atmosphere may reasonably be anticipated to endanger the public health and welfare of current and future generations.” (81 FR 54424, August 15, 2016).

Since the 2016 Endangerment Findings, the climate has continued to change, with new records being set for several climate indicators such as global average surface temperatures, GHG concentrations, and sea level rise. Moreover, heavy precipitation events have increased in the eastern U.S. while agricultural and ecological drought has increased in the western U.S. along with more intense and larger wildfires.²⁹ These and other trends are examples of the risks discussed the 2009 and 2016 Endangerment Findings that have already been experienced. Additionally, major scientific assessments continue to demonstrate advances in our understanding of the climate system and the impacts that GHGs have on public health and welfare both for current and future generations. These updated observations and projections document the rapid rate of current and future climate change both globally and in the U.S. These assessments include:

²⁸ In describing these 2016 Findings in this proposal, the EPA is neither reopening nor revisiting them.

²⁹ See later in this section of the document for specific examples. An additional resource for indicators can be found at <https://www.epa.gov/climate-indicators>.

²⁶ In describing these 2009 Findings in this proposal, the EPA is neither reopening nor revisiting them.

- U.S. Global Change Research Program's (USGCRP) 2016 Climate and Health Assessment³⁰ and 2017–2018 Fourth National Climate Assessment (NCA4)^{31 32}
- IPCC's 2018 Global Warming of 1.5 °C,³³ 2019 Climate Change and Land,³⁴ and the 2019 Ocean and Cryosphere in a Changing Climate³⁵ assessments, as well as the 2023 IPCC Sixth Assessment Report (AR6).³⁶
- The NAS 2016 Attribution of Extreme Weather Events in the Context of Climate Change,³⁷ 2017 Valuing Climate Damages: Updating Estimation

³⁰ USGCRP, 2016: *The Impacts of Climate Change on Human Health in the United States: A Scientific Assessment*. Crimmins, A., J. Balbus, J.L. Gamble, C.B. Beard, J.E. Bell, D. Dodgen, R.J. Eisen, N. Fann, M.D. Hawkins, S.C. Herring, L. Jantarassami, D.M. Mills, S. Saha, M.C. Sarofim, J. Trtanj, and L. Ziska, Eds. U.S. Global Change Research Program, Washington, DC, 312 pp.

³¹ USGCRP, 2017: *Climate Science Special Report: Fourth National Climate Assessment*, Volume I [Wuebbles, D.J., D.W. Fahey, K.A. Hibbard, D.J. Dokken, B.C. Stewart, and T.K. Maycock (eds.)]. U.S. Global Change Research Program, Washington, DC, USA, 470 pp. doi: 10.7930/J0J964J6.

³² USGCRP, 2018: *Impacts, Risks, and Adaptation in the United States: Fourth National Climate Assessment, Volume II* [Reidmiller, D.R., C.W. Avery, D.R. Easterling, K.E. Kunkel, K.L.M. Lewis, T.K. Maycock, and B.C. Stewart (eds.)]. U.S. Global Change Research Program, Washington, DC, USA, 1515 pp. doi:10.7930/NCA4.2018.

³³ IPCC, 2018: *Global Warming of 1.5 °C*. An IPCC Special Report on the impacts of global warming of 1.5 °C above pre-industrial levels and related global greenhouse gas emission pathways, in the context of strengthening the global response to the threat of climate change, sustainable development, and efforts to eradicate poverty [Masson-Delmotte, V., P. Zhai, H.-O. Pörtner, D. Roberts, J. Skea, P.R. Shukla, A. Pirani, W. Moufouma-Okia, C. Péan, R. Pidcock, S. Connors, J.B.R. Matthews, Y. Chen, X. Zhou, M.I. Gomis, E. Lonnoy, T. Maycock, M. Tignor, and T. Waterfield (eds.)].

³⁴ IPCC, 2019: *Climate Change and Land: an IPCC special report on climate change, desertification, land degradation, sustainable land management, food security, and greenhouse gas fluxes in terrestrial ecosystems* [P.R. Shukla, J. Skea, E. Calvo Buendia, V. Masson-Delmotte, H.-O. Pörtner, D. C. Roberts, P. Zhai, R. Slade, S. Connors, R. van Diemen, M. Ferrat, E. Haughey, S. Luz, S. Neogi, M. Pathak, J. Petzold, J. Portugal Pereira, P. Vyas, E. Huntley, K. Kissick, M. Belkacemi, J. Malley, (eds.)].

³⁵ IPCC, 2019: *IPCC Special Report on the Ocean and Cryosphere in a Changing Climate* [H.-O. Pörtner, DC Roberts, V. Masson-Delmotte, P. Zhai, M. Tignor, E. Poloczanska, K. Mintenbeck, A. Alegria, M. Nicolai, A. Okem, J. Petzold, B. Rama, N.M. Weyer (eds.)].

³⁶ IPCC, 2023: Summary for Policymakers. In: *Climate Change 2023: Synthesis Report*. Contribution of Working Groups I, II and III to the Sixth Assessment Report of the Intergovernmental Panel on Climate Change [Core Writing Team, H. Lee and J. Romero (eds.)]. IPCC, Geneva, Switzerland, pp. 1–34, doi:10.59327/IPCC/AR6–9789291691647.001.

³⁷ National Academies of Sciences, Engineering, and Medicine. 2016. *Attribution of Extreme Weather Events in the Context of Climate Change*. Washington, DC: The National Academies Press. <https://doi.org/10.17226/21852>.

of the Social Cost of Carbon Dioxide,³⁸ and 2019 Climate Change and Ecosystems³⁹ assessments.

• National Oceanic and Atmospheric Administration's (NOAA) annual State of the Climate reports published by the Bulletin of the American Meteorological Society,⁴⁰ most recently in 2022.

• EPA Climate Change and Social Vulnerability in the United States: A Focus on Six Impacts (2021).⁴¹

The most recent information demonstrates that the climate is continuing to change in response to the human-induced buildup of GHGs in the atmosphere. These recent assessments show that atmospheric concentrations of GHGs have risen to a level that has no precedent in human history and that they continue to climb, primarily because of both historical and current anthropogenic emissions, and that these elevated concentrations endanger our health by affecting our food and water sources, the air we breathe, the weather we experience, and our interactions with the natural and built environments. For example, atmospheric concentrations of one of these GHGs, CO₂, measured at Mauna Loa in Hawaii and at other sites around the world reached 419 parts per million (ppm) in 2022 (nearly 50 percent higher than preindustrial levels)⁴² and have continued to rise at a rapid rate. Global average temperature has increased by about 1.1 °C (2.0 °F) in the 2011–2020 decade relative to 1850–1900.⁴³ The years 2015–2021 were the warmest 7 years in the 1880–2021 record, contributing to the warmest decade on record with a decadal temperature of

³⁸ National Academies of Sciences, Engineering, and Medicine. 2017. *Valuing Climate Damages: Updating Estimation of the Social Cost of Carbon Dioxide*. Washington, DC: The National Academies Press. <https://doi.org/10.17226/24651>.

³⁹ National Academies of Sciences, Engineering, and Medicine. 2019. *Climate Change and Ecosystems*. Washington, DC: The National Academies Press. <https://doi.org/10.17226/25504>.

⁴⁰ Blunden, J. and T. Boyer, Eds., 2022: "State of the Climate in 2021". Bull. Amer. Meteor. Soc., 103 (8), Si–S465, <https://doi.org/10.1175/2022BAMS.StateoftheClimate.1>.

⁴¹ EPA. 2021. *Climate Change and Social Vulnerability in the United States: A Focus on Six Impacts*. U.S. Environmental Protection Agency, EPA 430–R–21–003.

⁴² https://gml.noaa.gov/webdata/ccgg/trends/co2/co2_annmean_mlo.txt.

⁴³ IPCC, 2021: Summary for Policymakers. In: *Climate Change 2021: The Physical Science Basis*. Contribution of Working Group I to the Sixth Assessment Report of the Intergovernmental Panel on Climate Change [Masson-Delmotte, V., P. Zhai, A. Pirani, S.L. Connors, C. Péan, S. Berger, N. Caud, Y. Chen, L. Goldfarb, M.I. Gomis, M. Huang, K. Leitzell, E. Lonnoy, J.B.R. Matthews, T.K. Maycock, T. Waterfield, O. Yelekçi, R. Yu, and B. Zhou (eds.)]. Cambridge University Press, Cambridge, United Kingdom and New York, NY, USA, pp. 3–32, doi:10.1017/9781009157896.001.

0.82 °C (1.48 °F) above the 20th century.^{44 45} The IPCC determined (with medium confidence) that this past decade was warmer than any multi-century period in at least the past 100,000 years.⁴⁶ Global average sea level has risen by about 8 inches (about 21 centimeters (cm)) from 1901 to 2018, with the rate from 2006 to 2018 (0.15 inches/year or 3.7 millimeters (mm)/year) almost twice the rate over the 1971 to 2006 period, and three times the rate of the 1901 to 2018 period.⁴⁷ The rate of sea level rise over the 20th century was higher than in any other century in at least the last 2,800 years.⁴⁸ Higher CO₂ concentrations have led to acidification of the surface ocean in recent decades to an extent unusual in the past 2 million years, with negative impacts on marine organisms that use calcium carbonate to build shells or skeletons.⁴⁹ Arctic sea ice extent continues to decline in all months of the year; the most rapid reductions occur in September (very likely almost a 13 percent decrease per decade between 1979 and 2018) and are unprecedented in at least 1,000 years.⁵⁰ Human-induced climate change has led to heatwaves and heavy precipitation becoming more frequent and more intense, along with increases in agricultural and ecological droughts⁵¹ in many regions.⁵²

The assessment literature demonstrates that modest additional amounts of warming may lead to a climate different from anything humans have ever experienced. The 2022 CO₂ concentration of 419 ppm is already higher than at any time in the last 2 million years.⁵³ If concentrations exceed 450 ppm, they would likely be higher than any time in the past 23 million years:⁵⁴ at the current rate of increase of more than 2 ppm a year, this would

⁴⁴ NOAA National Centers for Environmental Information, State of the Climate 2021 retrieved on August 3, 2023, from <https://www.ncei.noaa.gov/bams-state-of-climate>.

⁴⁵ Blunden, et al. 2022.

⁴⁶ IPCC, 2021.

⁴⁷ IPCC, 2021.

⁴⁸ USGCRP, 2018: *Impacts, Risks, and Adaptation in the United States: Fourth National Climate Assessment, Volume II* [Reidmiller, D.R., C.W. Avery, D.R. Easterling, K.E. Kunkel, K.L.M. Lewis, T.K. Maycock, and B.C. Stewart (eds.)]. U.S. Global Change Research Program, Washington, DC, USA, 1515 pp. doi:10.7930/NCA4.2018.

⁴⁹ IPCC, 2021.

⁵⁰ IPCC, 2021.

⁵¹ These are drought measures based on soil moisture.

⁵² IPCC, 2021.

⁵³ Annual Mauna Loa CO₂ concentration data from https://gml.noaa.gov/webdata/ccgg/trends/co2/co2_annmean_mlo.txt, accessed September 9, 2023.

⁵⁴ IPCC, 2013.

occur in about 15 years. While GHGs are not the only factor that controls climate, it is illustrative that 3 million years ago (the last time CO₂ concentrations were above 400 ppm) Greenland was not yet completely covered by ice and still supported forests, while 23 million years ago (the last time concentrations were above 450 ppm) the West Antarctic ice sheet was not yet developed, indicating the possibility that high GHG concentrations could lead to a world that looks very different from today and from the conditions in which human civilization has developed. If the Greenland and Antarctic ice sheets were to melt substantially, sea levels would rise dramatically—the IPCC estimated that over the next 2,000 years, sea level will rise by 7 to 10 feet even if warming is limited to 1.5 °C (2.7 °F), from 7 to 20 feet if limited to 2 °C (3.6 °F), and by 60 to 70 feet if warming is allowed to reach 5 °C (9 °F) above preindustrial levels.⁵⁵ For context, almost all of the city of Miami is less than 25 feet above sea level, and the NCA4 stated that 13 million Americans would be at risk of migration due to 6 feet of sea level rise. Moreover, the CO₂ being absorbed by the ocean has resulted in changes in ocean chemistry due to acidification of a magnitude not seen in 65 million years,⁵⁶ putting many marine species—particularly calcifying species—at risk.

The NCA4 found that it is very likely (greater than 90 percent likelihood) that by mid-century, the Arctic Ocean will be almost entirely free of sea ice by late summer for the first time in about 2 million years.⁵⁷ Coral reefs will be at risk for almost complete (99 percent) losses with 1 °C (1.8 °F) of additional warming from today (2 °C or 3.6 °F since preindustrial). At this temperature, between 8 and 18 percent of animal, plant, and insect species could lose over half of the geographic area with suitable climate for their survival, and 7 to 10 percent of rangeland livestock would be projected to be lost.⁵⁸ The IPCC similarly found that climate change has caused substantial damages and increasingly irreversible losses in terrestrial, freshwater, and coastal and open ocean marine ecosystems.

Scientific assessments also demonstrate that even modest

additional amounts of warming may lead to a climate different from anything humans have ever experienced. Every additional increment of temperature comes with consequences. For example, the half degree of warming from 1.5 to 2 °C (0.9 °F) of warming from 2.7 °F to 3.6 °F) above preindustrial temperatures is projected on a global scale to expose 420 million more people to frequent extreme heatwaves, and 62 million more people to frequent exceptional heatwaves (where heatwaves are defined based on a heat wave magnitude index which takes into account duration and intensity—using this index, the 2003 French heat wave that led to almost 15,000 deaths would be classified as an “extreme heatwave” and the 2010 Russian heatwave which led to thousands of deaths and extensive wildfires would be classified as “exceptional”). It would increase the frequency of sea-ice-free Arctic summers from once in 100 years to once in a decade. It could lead to 4 inches of additional sea level rise by the end of the century, exposing an additional 10 million people to risks of inundation as well as increasing the probability of triggering instabilities in either the Greenland or Antarctic ice sheets. Between half a million and a million additional square miles of permafrost would thaw over several centuries. Risks to food security would increase from medium-to-high for several lower-income regions in the Sahel, southern Africa, the Mediterranean, central Europe, and the Amazon. In addition to food security issues, this temperature increase would have implications for human health in terms of increasing ozone concentrations, heatwaves, and vector-borne diseases (for example, expanding the range of the mosquitoes which carry dengue fever, chikungunya, yellow fever, and the Zika virus, or the ticks which carry Lyme, babesiosis, or Rocky Mountain Spotted Fever).⁵⁹ Moreover, every additional increment in warming leads to larger changes in extremes, including the potential for events unprecedented in the observational record. Every additional degree will intensify extreme precipitation events by about 7 percent. The peak winds of the most intense tropical cyclones (hurricanes) are projected to increase with warming. In addition to a higher intensity, the IPCC

found that precipitation and frequency of rapid intensification of these storms has already increased, the movement speed has decreased, and elevated sea levels have increased coastal flooding, all of which make these tropical cyclones more damaging.⁶⁰

The NCA4 also evaluated a number of impacts specific to the U.S. Severe drought and outbreaks of insects like the mountain pine beetle have killed hundreds of millions of trees in the western U.S. Wildfires have burned more than 3.7 million acres in 14 of the 17 years between 2000 and 2016, and Federal wildfire suppression costs were about a billion dollars annually.⁶¹ The National Interagency Fire Center has documented U.S. wildfires since 1983, and the 10 years with the largest acreage burned have all occurred since 2004.⁶² Wildfire smoke degrades air quality, increasing health risks, and more frequent and severe wildfires due to climate change would further diminish air quality, increase incidences of respiratory illness, impair visibility, and disrupt outdoor activities, sometimes thousands of miles from the location of the fire. Meanwhile, sea level rise has amplified coastal flooding and erosion impacts, requiring the installation of costly pump stations, flooding streets, and increasing storm surge damages. Tens of billions of dollars of U.S. real estate could be below sea level by 2050 under some scenarios. Increased frequency and duration of drought will reduce agricultural productivity in some regions, accelerate depletion of water supplies for irrigation, and expand the distribution and incidence of pests and diseases for crops and livestock. The NCA4 also recognized that climate change can increase risks to national security, both through direct impacts on military infrastructure and by affecting factors such as food and water availability that can exacerbate conflict outside U.S. borders. Droughts, floods, storm surges, wildfires, and other extreme events stress nations and people through loss of life, displacement of populations, and impacts on livelihoods.⁶³

⁵⁵ IPCC, 2021.

⁵⁶ USGCRP, 2018.

⁶¹ NIFC (National Interagency Fire Center). 2021. Total wildland fires and acres (1983–2020). Accessed August 2021. www.nifc.gov/fireInfo/fireInfo_stats_totalFires.html.

⁶² USGCRP, 2018.

⁵⁵ IPCC, 2021.

⁵⁶ IPCC, 2018.

⁵⁷ USGCRP, 2018.

⁵⁸ IPCC, 2018.

⁵⁹ IPCC, 2018.

Ongoing EPA modeling efforts can shed further light on the distribution of climate change damages expected to occur within the U.S. Based on methods from over 30 peer-reviewed climate change impact studies, the EPA's Framework for Evaluating Damages and Impacts (FrEDI) model has developed estimates of the relationship between future temperature changes and physical and economic climate-driven damages occurring in specific U.S. regions for 20 specific impact categories.⁶⁴ Recent applications of FrEDI have advanced the collective understanding about how future climate change impacts in these 20 categories are expected to be substantial and distributed unevenly across U.S. regions.⁶⁵ Using this framework, the EPA estimates that under a global emission scenario with no additional mitigation, relative to a world with no additional warming since the baseline period (1986–2005), damages accruing to these impact categories in the contiguous U.S. occur mainly through increased deaths due to increasing temperatures as well as climate-driven changes in air quality, transportation impacts due to coastal flooding resulting from sea level rise, increased mortality from wildfire emission exposure and response costs for fire suppression, and reduced labor hours worked in outdoor settings and buildings without air conditioning. The relative damages from long-term climate driven changes in these sectors are also projected to vary from region to region. For example, of the impact categories examined in FrEDI, the largest source of modeled damages differ from region to region, with wildfire impacts in the Northwest, air quality impacts on the East Coast

and the Southwest, labor productivity impacts in the Midwest, transportation impacts from high tide flooding in the Southern Plains, and damages to rail infrastructure in the Northern Plains. While the FrEDI framework currently quantifies damages for 20 impact categories within the contiguous U.S., it is important to note that it is still a preliminary and partial assessment of climate impacts relevant to U.S. interests in a number of ways. For example, the FrEDI framework reflects some important health damages from U.S. wildfires (*i.e.*, mortality and morbidity impacts from wildfire smoke) and suppression costs, but do not yet account for other market and non-market welfare effects of wildfires (*e.g.*, property damage, impacts to ecosystem services, climate feedback effects from wildfire CO₂ emissions). Similarly, FrEDI models several types of damages from SLR (*e.g.*, traffic delays due to flooded coastal roadways) but do not reflect others, such as the effect of groundwater intrusion, business interruptions, debris removal costs, or critical infrastructure loss. In addition, FrEDI does not reflect increased damages that occur due to climate-mediated effects to ecosystem services, or national security, interactions between different sectors impacted by climate change or all the ways in which physical impacts of climate change occurring abroad have spillover effects in different regions of the U.S. See the FrEDI Technical Documentation⁶⁶ for more details.

Some GHGs also have impacts beyond those mediated through climate change. For example, elevated concentrations of CO₂ stimulate plant growth (which can be positive in the case of beneficial species, but negative in terms of weeds and invasive species, and can also lead to a reduction in plant micronutrients⁶⁷) and cause ocean acidification. Nitrous oxide depletes the levels of protective stratospheric ozone.⁶⁸

As methane is the primary GHG addressed in this rulemaking, it is relevant to highlight some trends and impacts specific to methane. Concentrations of methane reached 1,912 parts per billion (ppb) in 2022, more than two and a half times the preindustrial concentration of 722 ppb.⁶⁹ Moreover, the 2022 concentration was an increase of almost 17 ppb over 2021—the largest annual increase in methane concentrations in the dataset (starting in 1984), continuing a trend of rapid rise since a temporary pause ended in 2007.⁷⁰ Methane has a high radiative efficiency—almost 30 times that of CO₂ per ppb (and, therefore, 80 times as much per unit mass).⁷¹ In addition, methane contributes to climate change through chemical reactions in the atmosphere that produce tropospheric ozone and stratospheric water vapor. Human emissions of methane are responsible for about one-third of the warming due to well-mixed GHGs, the second most important human warming agent after CO₂.⁷² Because of the substantial emissions of methane, and its radiative efficiency, methane mitigation is one of the best opportunities for reducing near-term warming.

The tropospheric ozone produced by the reaction of methane in the atmosphere has harmful effects for human health and plant growth in addition to its climate effects.⁷³ In remote areas, methane is an important precursor to tropospheric ozone formation.⁷⁴ Approximately 50 percent of the global annual mean ozone increase since preindustrial times is believed to be due to anthropogenic methane.⁷⁵ Projections of future

⁶⁹ Blunden, *et al.*, 2022.

⁷⁰ NOAA, https://gml.noaa.gov/webdata/ccgg/trends/ch4/ch4_annmean_gl.txt, accessed August 3, 2023.

⁷¹ IPCC, 2021.

⁷² IPCC, 2021.

⁷³ Nolte, C.G., P.D. Dolwick, N. Fann, L.W. Horowitz, V. Naik, R.W. Pinder, T.L. Spero, D.A. Winner, and L.H. Ziska, 2018: *Air Quality. In Impacts, Risks, and Adaptation in the United States: Fourth National Climate Assessment*, Volume II [Reidmiller, D.R., C.W. Avery, D.R. Easterling, K.E. Kunkel, K.L.M. Lewis, T.K. Maycock, and B.C. Stewart (eds.)]. U.S. Global Change Research Program, Washington, DC, USA, pp. 512–538. doi:10.7930/NCA4.2018.CH13.

⁷⁴ U.S. EPA. 2013. “*Integrated Science Assessment for Ozone and Related Photochemical Oxidants (Final Report)*.” EPA/600–R–10–076F. National Center for Environmental Assessment—RTP Division. Available at <https://www.epa.gov/ncea/isa/>.

⁷⁵ Myhre, G., D. Shindell, F.-M. Bréon, W. Collins, J. Fuglestvedt, J. Huang, D. Koch, J.-F. Lamarque, D. Lee, B. Mendoza, T. Nakajima, A. Robock, G. Stephens, T. Takemura and H. Zhang, 2013: *Anthropogenic and Natural Radiative Forcing. In: Climate Change 2013: The Physical Science Basis. Contribution of Working Group I to the Fifth*

⁶⁴ EPA (2021). *Technical Documentation on the Framework for Evaluating Damages and Impacts (FrEDI)*. U.S. Environmental Protection Agency, EPA 430–R–21–004, available at <https://www.epa.gov/cira/fredi>. Documentation has been subject to both a public review comment period and an independent expert peer review, following EPA peer-review guidelines.

⁶⁵ (1) Sarofim, M.C., Martinich, J., Neumann, J.E., *et al.* (2021). *A temperature binning approach for multi-sector climate impact analysis*. *Climate Change* 165. <https://doi.org/10.1007/s10584-021-03048-6>. (2) *Supplementary Material for the Regulatory Impact Analysis for the Supplemental Proposed Rulemaking, “Standards of Performance for New, Reconstructed, and Modified Sources and Emissions Guidelines for Existing Sources: Oil and Natural Gas Sector Climate Review.”* Docket ID No. EPA–HQ–OAR–2021–0317, September 2022. (3) *The Long-Term Strategy of the United States: Pathways to Net-Zero Greenhouse Gas Emissions by 2050*. Published by the U.S. Department of State and the U.S. Executive Office of the President, Washington DC, November 2021. (4) *Climate Risk Exposure: An Assessment of the Federal Government's Financial Risks to Climate Change*, White Paper, Office of Management and Budget, April 2022.

⁶⁶ EPA (2021). *Technical Documentation on the Framework for Evaluating Damages and Impacts (FrEDI)*. U.S. Environmental Protection Agency, EPA 430–R–21–004, available at <https://www.epa.gov/cira/fredi>.

⁶⁷ Ziska, L., A. Crimmins, A. Auclair, S. DeGrasse, J.F. Garofalo, A.S. Khan, I. Loladze, A.A. Pérez de León, A. Showler, J. Thurston, and I. Walls, 2016: Ch. 7: *Food Safety, Nutrition, and Distribution. The Impacts of Climate Change on Human Health in the United States: A Scientific Assessment*. U.S. Global Change Research Program, Washington, DC, 189–216. https://health2016.globalchange.gov/low/ClimateHealth2016_07_Food_small.pdf.

⁶⁸ WMO (World Meteorological Organization), *Scientific Assessment of Ozone Depletion: 2018, Global Ozone Research and Monitoring Project—Report No. 58*, 588 pp., Geneva, Switzerland, 2018.

emissions also indicate that methane is likely to be a key contributor to ozone concentrations in the future.⁷⁶ Unlike NO_x and VOC, which affect ozone concentrations regionally and at hourly time scales, methane emissions affect ozone concentrations globally and on decadal time scales given methane's long atmospheric lifetime when compared to these other ozone precursors.⁷⁷ Reducing methane emissions, therefore, will contribute to efforts to reduce global background ozone concentrations that contribute to the incidence of ozone-related health effects.⁷⁸ The benefits of such reductions are global and occur in both urban and rural areas.

These scientific assessments, the EPA analyses, and documented observed changes in the climate of the planet and of the U.S. present clear support regarding the current and future dangers of climate change and the importance of GHG emissions mitigation.

2. VOCs

Many VOCs can be classified as HAP (e.g., benzene⁷⁹) and can lead to a variety of health concerns such as cancer and noncancer illnesses (e.g., respiratory, neurological). Further, VOCs are one of the key precursors in the formation of ozone. Tropospheric, or ground-level, ozone is formed through reactions of VOCs and NO_x in the presence of sunlight. Ozone formation can be controlled to some extent through reductions in emissions of the ozone precursors VOC and NO_x. Recent observational and modeling studies have found that VOC emissions from oil and natural gas operations can impact ozone levels.^{80 81 82 83} A significantly

Assessment Report of the Intergovernmental Panel on Climate Change [Stocker, T.F., D. Qin, G.-K. Plattner, M. Tignor, S.K. Allen, J. Boschung, A. Nauels, Y. Xia, V. Bex and P.M. Midgley (eds.)]. Cambridge University Press, Cambridge, United Kingdom and New York, NY, USA. Pg. 680.

⁷⁶ *Ibid.*

⁷⁷ *Ibid.*

⁷⁸ USGCRP, 2018.

⁷⁹ Benzene Integrated Risk Information System (IRIS) Assessment: https://cfpub.epa.gov/ncea/iris2/chemicalLanding.cfm?substance_nmbr=276.

⁸⁰ Benedict, K. B., Zhou, Y., Sive, B. C., Prenni, A. J., Gebhart, K. A., Fischer, E. V., . . . & Collett Jr, J. L. 2019. Volatile organic compounds and ozone in Rocky Mountain National Park during FRAPPE. *Atmospheric Chemistry and Physics*, 19(1), 499–521.

⁸¹ Lindaas, J., Farmer, D. K., Pollack, I. B., Abeleira, A., Flocke, F., & Fischer, E. V. 2019. Acyl peroxy nitrates link oil and natural gas emissions to high ozone abundances in the Colorado Front Range during summer 2015. *Journal of Geophysical Research: Atmospheres*, 124(4), 2336–2350.

⁸² McDuffie, E. E., Edwards, P. M., Gilman, J. B., Lerner, B. M., Dubé, W. P., Trainer, M., . . . & Brown, S. S. 2016. Influence of oil and gas emissions on summertime ozone in the Colorado

expanded body of scientific evidence shows that ozone can cause a number of harmful effects on health and the environment. Exposure to ozone can cause respiratory system effects such as difficulty breathing and airway inflammation. For people with lung diseases such as asthma and chronic obstructive pulmonary disease (COPD), these effects can lead to emergency room visits and hospital admissions. Studies have also found that ozone exposure is likely to cause premature death from lung or heart diseases. In addition, evidence indicates that long-term exposure to ozone is likely to result in harmful respiratory effects, including respiratory symptoms and the development of asthma. People most at risk from breathing air containing ozone include: children; people with asthma and other respiratory diseases; older adults; and people who are active outdoors, especially outdoor workers. An estimated 25.9 million people have asthma in the U.S., including almost 7.1 million children. Asthma disproportionately affects children, families with lower incomes, and minorities, including Puerto Ricans, Native Americans/Alaska Natives, and African Americans.⁸⁴

In the EPA's 2020 Integrated Science Assessment (ISA) for Ozone and Related Photochemical Oxidants,⁸⁵ the EPA estimated the incidence of air pollution effects for those health endpoints above where the ISA classified as either causal or likely-to-be-causal. In brief, the ISA for ozone found short-term (less than one month) exposures to ozone to be causally related to respiratory effects, a "likely to be causal" relationship with metabolic effects and a "suggestive of, but not sufficient to infer, a causal relationship" for central nervous system effects, cardiovascular effects, and total mortality. The ISA reported that long-term exposures (one month or longer) to ozone are "likely to be causal" for respiratory effects including respiratory mortality, and a "suggestive of, but not sufficient to infer, a causal relationship" for cardiovascular effects, reproductive effects, central nervous system effects, metabolic effects, and total mortality.

Northern Front Range. *Journal of Geophysical Research: Atmospheres*, 121(14), 8712–8729.

⁸³ Tzompa-Sosa, Z. A., & Fischer, E. V. 2021. Impacts of emissions of C2-C5 alkanes from the US oil and gas sector on ozone and other secondary species. *Journal of Geophysical Research: Atmospheres*, 126(1), e2019JD031935.

⁸⁴ National Health Interview Survey (NHIS) Data, 2011. <https://www.cdc.gov/asthma/nhis/2011/data.htm>.

⁸⁵ Integrated Science Assessment (ISA) for Ozone and Related Photochemical Oxidants (Final Report). U.S. Environmental Protection Agency, Washington, DC, EPA/600/R-20/012, 2020.

An example of quantified incidence of ozone health effects can be found in the Regulatory Impact Analysis for the Final Revised Cross-State Air Pollution Rule (CSAPR) Update.⁸⁶

Scientific evidence also shows that repeated exposure to ozone can reduce growth and have other harmful effects on sensitive plants and trees. These types of effects have the potential to impact ecosystems and the benefits they provide.

3. SO₂

Current scientific evidence links short-term exposures to SO₂, ranging from 5 minutes to 24 hours, with an array of adverse respiratory effects including bronchoconstriction and increased asthma symptoms. These effects are particularly important for asthmatics at elevated ventilation rates (e.g., while exercising or playing).

Studies also show an association between short-term exposure and increased visits to emergency departments and hospital admissions for respiratory illnesses, particularly in at-risk populations including children, the elderly, and asthmatics.

SO₂ in the air can also damage the leaves of plants, decrease their ability to produce food (photosynthesis), and decrease their growth. In addition to directly affecting plants, SO₂, when deposited on land and in estuaries, lakes, and streams, can acidify sensitive ecosystems resulting in a range of harmful indirect effects on plants, soils, water quality, and fish and wildlife (e.g., changes in biodiversity and loss of habitat, reduced tree growth, loss of fish species). Sulfur deposition to waterways also plays a causal role in the methylation of mercury.⁸⁷

B. Profile of the Oil and Natural Gas Industry and Its Emissions

This section of the preamble generally describes: the structure of the oil and natural gas industry; the interconnected production, processing, transmission and storage, and distribution segments that move product from well to market; and types of emissions sources in each segment and the industry's emissions.

⁸⁶ U.S. EPA. *Technical Support Document (TSD) for the Final Revised Cross-State Air Pollution Rule Update for the 2008 Ozone Season NAAQS Estimating PM 2.5-and Ozone-Attributable Health Benefits*. 2021. Research Triangle Park, NC.

⁸⁷ U.S. EPA. *Integrated Science Assessment (ISA) for Oxides of Nitrogen and Sulfur Ecological Criteria* (2008 Final Report). U.S. Environmental Protection Agency, Washington, DC, EPA/600/R-08/082F, 2008.

1. Structure of the Oil and Natural Gas Industry

The EPA characterizes the oil and natural gas industry's operations as being generally composed of four segments: (1) Extraction and production of crude oil and natural gas ("oil and natural gas production"), (2) natural gas processing, (3) natural gas transmission and storage, and (4) natural gas distribution.^{88 89} The EPA regulates oil refineries as a separate source category; accordingly, as with the previous oil and gas NSPS rulemakings, for purposes of this rulemaking, the EPA's focus for crude oil is on operations from the well to the point of custody transfer at a petroleum refinery while the focus for natural gas is on all operations from the well to the local distribution company custody transfer station, commonly referred to as the "city-gate."⁹⁰

a. Production Segment

The oil and natural gas production segment includes the wells and all related processes used in the extraction, production, recovery, lifting, stabilization, and separation or treatment of oil and/or natural gas (including condensate). Although many wells produce a combination of oil and natural gas, wells can generally be grouped into two categories: oil wells and natural gas wells. Oil wells comprise two types, oil wells that produce crude oil only and oil wells that produce both crude oil and natural gas (commonly referred to as "associated" gas). Production equipment and components located on the well pad may include, but are not limited to: wells and related casing heads; tubing heads; "Christmas tree" piping, pumps, and compressors; heater treaters; separators; storage vessels; process controllers; pumps; and dehydrators. Production operations include well drilling, completion, and

⁸⁸ The EPA previously described an overview of the sector in section 2.0 of the 2011 Background TSD to 40 CFR part 60, subpart OOOO, located at Document ID No. EPA-HQ-OAR-2010-0505-0045, and section 2.0 of the 2016 Background TSD to 40 CFR part 60, subpart OOOOa, located at Document ID No. EPA-HQ-OAR-2010-0505-7631.

⁸⁹ While generally oil and natural gas production includes both onshore and offshore operations, 40 CFR part 60, subpart OOOOa, addresses onshore operations.

⁹⁰ For regulatory purposes, the EPA defines the Crude Oil and Natural Gas source category to mean (1) crude oil production, which includes the well and extends to the point of custody transfer to the crude oil transmission pipeline or any other forms of transportation; and (2) natural gas production, processing, transmission, and storage, which include the well and extend to, but do not include, the local distribution company custody transfer station. The distribution segment is not part of the defined source category.

recompletion processes, including all the portable non-self-propelled apparatuses associated with those operations.

Other sites that are part of the production segment include "centralized tank batteries," stand-alone sites where oil, condensate, produced water, and natural gas from several wells may be separated, stored, or treated. The production segment also includes gathering pipelines, gathering and boosting compressor stations, and related components that collect and transport the oil, natural gas, and other materials and wastes from the wells to the refineries or natural gas processing plants.

Crude oil and natural gas undergo successive, separate processing. Crude oil is separated from water and other impurities and transported to a refinery via truck, railcar, or pipeline. As noted above, the EPA treats oil refineries as a separate source category; accordingly, for present purposes, the oil component of the production segment ends at the point of custody transfer at the refinery.⁹¹

The separated, unprocessed natural gas is commonly referred to as field gas and is composed of methane, natural gas liquids (NGL), and other impurities such as water vapor, H₂S, CO₂, helium, and nitrogen. Ethane, propane, butane, isobutane, and pentane are all considered NGL and often are sold separately for a variety of different uses. Natural gas with high methane content is referred to as "dry gas," while natural gas with significant amounts of ethane, propane, or butane is referred to as "wet gas." Natural gas is typically sent to gas processing plants in order to separate NGLs for use as feedstock for petrochemical plants, fuel for space heating and cooking, or a component for blending into vehicle fuel.

b. Processing Segment

The natural gas processing segment consists of separating certain hydrocarbons (HC) and fluids from the natural gas to produce "pipeline quality" dry natural gas. The degree and location of processing is dependent on factors such as the type of natural gas (e.g., wet or dry gas), market conditions, and company contract specifications. Typically, processing of natural gas begins in the field and continues as the gas is moved from the field through gathering and boosting compressor stations to natural gas processing plants, where the complete processing of natural gas takes place. Natural gas

⁹¹ See 40 CFR part 60, subparts J and Ja, and 40 CFR part 63, subparts CC and UUU.

processing operations separate and recover NGL or other non-methane gases and liquids from field gas through one or more of the following processes: oil and condensate separation, water removal, separation of NGL, sulfur and CO₂ removal, fractionation of NGL, and other processes, such as the capture of CO₂ separated from natural gas streams for delivery outside the facility.

c. Transmission and Storage Segment

Once natural gas processing is complete, the resulting natural gas exits the natural gas process plant and enters the transmission and storage segment where it is transmitted to storage and/or distribution to the end user.

Pipelines in the natural gas transmission and storage segment can be interstate pipelines, which carry natural gas across state boundaries, or intrastate pipelines, which transport the gas within a single state. Basic components of the two types of pipelines are the same, though interstate pipelines may be of a larger diameter and operated at a higher pressure. To ensure that the natural gas continues to flow through the pipeline, the natural gas must periodically be compressed, thereby increasing its pressure. Compressor stations perform this function and are usually placed at 40- to 100-mile intervals along the pipeline. At a compressor station, the natural gas enters the station, where it is compressed by reciprocating or centrifugal compressors.

Another part of the transmission and storage segment are aboveground and underground natural gas storage facilities. Storage facilities hold natural gas for use during peak seasons. The main difference between underground and aboveground storage sites is that storage takes place in storage vessels constructed of non-earthen materials in aboveground storage. Underground storage of natural gas typically occurs in depleted natural gas or oil reservoirs and salt dome caverns. One purpose of this storage is for load balancing (equalizing the receipt and delivery of natural gas). At an underground storage site, typically other processes occur, including compression, dehydration, and flow measurement.

d. Distribution Segment

The distribution segment provides the final step in delivering natural gas to customers.⁹² The natural gas enters the distribution segment from delivery points located along interstate and

⁹² The distribution segment is not included in the definition of the Crude Oil and Natural Gas source category in NSPS OOOO, NSPS OOOOa, NSPS OOOOb, or EG OOOOc.

intrastate transmission pipelines to business and household customers. The delivery point where the natural gas leaves the transmission and storage segment and enters the distribution segment is a local distribution company's custody transfer station, commonly referred to as the "city-gate." Natural gas distribution systems consist of over 2 million miles of piping, including mains and service pipelines to the customers. If the distribution network is large, compressor stations may be necessary to maintain flow. However, these stations are typically smaller than transmission compressor stations. Distribution systems include metering stations and regulating stations, which allow distribution companies to monitor the natural gas as it flows through the system.

2. Emissions From the Oil and Natural Gas Source Category

The oil and natural gas industry sector is the largest source of industrial methane emissions in the U.S.⁹³ Natural gas is composed primarily of methane; every natural gas leak or intentional release through venting or other industrial processes constitutes a release of methane. Methane is a potent GHG; over a 100-year timeframe, it is nearly 30 times more powerful at trapping climate warming heat than CO₂, and over a 20-year timeframe, it is 83 times more powerful.⁹⁴ Because methane is a powerful GHG and is emitted in large quantities, reductions in methane emissions provide a significant benefit in reducing near-term warming. Indeed, one-third of the warming due to GHGs that we are experiencing today is due to human-caused emissions of methane. Additionally, the Crude Oil and Natural Gas sector emits, in varying concentrations and amounts, a wide range of other health-harming pollutants, including VOCs, SO₂, NO_x, H₂S, CS₂, and COS. The year 2016 modeling platform produced by the EPA estimated about 3 million tons of VOC are emitted by oil and gas-related sources.⁹⁵

Emissions of methane and these co-pollutants occur in every segment of the Crude Oil and Natural Gas source category, which comprises the oil and natural gas production, natural gas processing, and natural gas transmission and storage segments of the larger industry. Many of the processes and

equipment types that contribute to these emissions are found in every segment of the source category and are highly similar across segments. Emissions from the crude oil portion of the regulated source category result primarily from field production operations, such as venting of associated gas from oil wells, oil storage vessels, and production-related equipment such as gas dehydrators, pig traps, process controllers, and pumps. Emissions from the natural gas portion of the industry can occur in all segments. As natural gas moves through the system, emissions primarily result from intentional venting through normal operations, routine maintenance, unintentional fugitive emissions, flaring, malfunctions, and system upsets. Venting can occur through equipment design or operational practices, such as the continuous bleed and intermittent venting of gas from process controllers (devices that control gas flows, levels, temperatures, and pressures in the equipment). In addition to vented emissions, emissions can occur from leaking equipment (also referred to as fugitive emissions) in all parts of the infrastructure, including major production and processing equipment (e.g., separators or storage vessels) and individual components (e.g., valves or connectors). Flares are commonly used throughout each segment in the oil and natural gas industry as a control device—to provide pressure relief to prevent risk of explosions; to destroy methane, which has a high global warming potential, and convert it to CO₂ which has a lower global warming potential; and to control other air pollutants such as VOC.

"Super-emitting" events, sites, or equipment, which refer to a small proportion of particularly highly emitting sources that account for a large proportion of overall emissions, can occur throughout the oil and natural gas industry and have been observed in the equipment types and activities covered by this final rulemaking. There are a number of definitions for the term "super-emitter." A 2018 National Academies of Sciences, Engineering, and Medicine report⁹⁶ on methane discussed three categories of "high-emitting" sources:

- Routine or "chronic" high-emitting sources, which regularly emit at higher rates relative to "peers" in a sample. Examples include large facilities and large emissions at smaller facilities caused by poor design or operational practices.

- Episodic high-emitting sources, which are typically large in nature and are generally intentional releases from known maintenance events at a facility. Examples include gas well liquids unloading, well workovers and maintenance activities, and compressor station or pipeline blowdowns.

- Malfunctioning high-emitting sources, which can be either intermittent or prolonged in nature and result from malfunctions and poor work practices. Examples include malfunctioning intermittent process controllers and stuck open dump valves. Another example is well blowout events. For example, a 2018 well blowout in Ohio was estimated to have emitted over 60,000 tons of methane.⁹⁷

Super-emitters have been observed at many different scales, from site-level to component-level, across many research studies.⁹⁸ Studies will often develop a study-specific definition such as a top percentile of emissions in a study population (e.g., top 10 percent), emissions exceeding a certain threshold (e.g., 26 kg/day), emissions over a certain detection threshold (e.g., 1–3 g/s) or as facilities with the highest proportional emission rate.⁹⁹ For certain equipment types and activities, the EPA's GHG emission estimates include the full range of conditions, including "super-emitters." For other situations, where data are available, emissions estimates for abnormal events are

⁹⁷ Pandey, et al. (2019). *Satellite observations reveal extreme methane leakage from a natural gas well blowout*. PNAS December 26, 2019. 116 (52) 26376–81.

⁹⁸ See, for example, Brandt, A., Heath, G., Cooley, D. (2016) *Methane Leaks from Natural Gas Systems Follow Extreme Distributions*. Environ. Sci. Technol., doi:10.1021/acs.est.6b04303; Zavala-Araiza, D., Alvarez, R.A., Lyon, D.R., Allen, D.T., Marchese, A.J., Zimmerle, D.J., & Hamburg, S.P. (2017). *Super-emitters in natural gas infrastructure are caused by abnormal process conditions*. *Nature communications*, 8, 14012; Mitchell, A., et al. (2015). *Measurements of Methane Emissions from Natural Gas Gathering Facilities and Processing Plants: Measurement Results*. Environmental Science & Technology, 49(5), 3219–3227; Allen, D., et al. (2014). *Methane Emissions from Process Equipment at Natural Gas Production Sites in the United States: Pneumatic Controllers*. Environmental Science & Technology.

⁹⁹ Caulton, et al. (2019). *Importance of Super-emitter Natural Gas Well Pads in the Marcellus Shale*. Environ. Sci. Technol. 2019, 53, 4747–4754; Zavala-Araiza, D., Alvarez, R., Lyon, D., et al. (2016). *Super-emitters in natural gas infrastructure are caused by abnormal process conditions*. Nat Commun 8, 14012 (2017). <https://www.nature.com/articles/ncomms14012>; Lyon, et al. (2016). *Aerial Surveys of Elevated Hydrocarbon Emissions from Oil and Gas Production Sites*. Environ. Sci. Technol. 2016, 50, 4877–4886. <https://pubs.acs.org/doi/10.1021/acs.est.6b00705>; and Zavala-Araiza D, et al. (2015). *Toward a functional definition of methane superemitters: Application to natural gas production sites*. Environ. Sci. Technol. 49, 8167–8174. <https://pubs.acs.org/doi/10.1021/acs.est.5b00133>.

⁹³ H.R. Rep. No. 117–64, 4 (2021) (Report by the House Committee on Energy and Commerce concerning H.J. Res. 34, to disapprove the 2020 Policy Rule) (House Report).

⁹⁴ IPCC, 2021.

⁹⁵ https://www.epa.gov/sites/default/files/2020-11/documents/2016v1_emismod_tsd_508.pdf.

⁹⁶ <https://www.nap.edu/download/24987#>.

calculated separately and included in the Inventory of U.S. Greenhouse Gas Emissions and Sinks (GHGI) (*e.g.*, Aliso Canyon leak event).¹⁰⁰ Given the variability of practices and technologies across oil and gas systems and the occurrence of episodic events, it is possible that the EPA’s estimates do not include all methane emissions from abnormal events. The EPA continues to engage with the research community and expert stakeholders to review new data from the EPA’s Greenhouse Gas Reporting Program (GHGRP) petroleum and natural gas systems source category (40 CFR part 98, subpart W, also referred to as “GHGRP subpart W”), as well as the peer-reviewed scientific literature and research studies to assess how emissions estimates can be improved. Because lost gas, whether through fugitive emissions, unintentional gas carry-through, or intentional releases, represents lost earning potential, the industry benefits from capturing and selling emissions of natural gas (and methane). Limiting super-emitters through actions included in this rulemaking such as reducing

fugitive emissions, using lower emitting equipment where feasible, and employing best management practices will not only reduce emissions but reduce the loss of revenue from this valuable commodity.

Below we provide estimated emissions of methane, VOC, and SO₂ from oil and natural gas industry operation sources.

a. Methane Emissions in the U.S. and From the Oil and Natural Gas Industry

Official U.S. estimates of national-level GHG emissions and sinks are developed by the EPA for the GHGI in fulfillment of commitments under the United Nations Framework Convention on Climate Change. The GHGI, which includes recent trends, is organized by industrial sector. The oil and natural gas production, natural gas processing, and natural gas transmission and storage sectors emit 28 percent of U.S. anthropogenic methane. Table 7 presents total U.S. anthropogenic methane emissions for the years 1990, 2010, and 2021.

In accordance with the practice of the EPA GHGI, the EPA GHGRP, and

international reporting standards under the U.N. Framework Convention on Climate Change, the 2007 IPCC Fourth Assessment Report value of the methane 100-year GWP is used for weighting emissions in the following tables. The 100-year GWP value of 28 for methane indicates that 1 ton of methane has approximately as much climate impact over a 100-year period as 28 tons of CO₂. The most recent IPCC AR6 assessment has calculated updated 100-year GWPs for methane of either 27.2 or 29.8 depending on whether the value includes the CO₂ produced by the oxidation of methane in the atmosphere. As mentioned earlier, because methane has a shorter lifetime than CO₂, the emissions of a ton of methane will have more impact earlier in the 100-year timespan and less impact later in the 100-year timespan relative to the emissions of a 100-year GWP-equivalent quantity of CO₂: when using the AR6 20-year GWP of 81, which only looks at impacts over the next 20 years, the total U.S. emissions of methane in 2021 would be equivalent to about 2,140 MMT CO₂.

TABLE 7—U.S. METHANE EMISSIONS BY SECTOR
[Million metric tons carbon dioxide equivalent (MMT CO₂ Eq.)]

Sector	1990	2010	2021
Oil and Natural Gas Production, and Natural Gas Processing and Transmission and Storage	206	224	202
Landfills	198	139	123
Enteric Fermentation	183	191	195
Coal Mining	108	92	45
Manure Management	39	59	66
Other Oil and Gas Sources	68	37	38
Wastewater Treatment	23	22	21
Other Methane Sources ¹⁰¹	44	44	38
Total Methane Emissions	869	808	727

Emissions from the Inventory of United States Greenhouse Gas Emissions and Sinks: 1990–2021 (published April 13, 2023), calculated using GWP of 28. Note: Totals may not sum due to rounding.

Table 8 presents total methane emissions from natural gas production through transmission and storage and petroleum production, for years 1990, 2010, and 2021, in MMT CO₂ Eq. (or million metric tons CO₂ Eq.) of methane.

TABLE 8—U.S. METHANE EMISSIONS FROM NATURAL GAS AND PETROLEUM SYSTEMS
[MMT CO₂ Eq.]

Sector	1990	2010	2021
Natural Gas Production	68	121	94
Natural Gas Processing	24	11	14
Natural Gas Transmission and Storage	64	39	45

¹⁰⁰ The EPA’s emission estimates in the GHGI are developed with the best data available at the time of their development, including data from the GHGRP in 40 CFR part 98, subpart W, and from recent research studies. GHGRP subpart W emissions data used in the GHGI are quantified by reporters using direct measurements, engineering

calculations, or emission factors, as specified by the regulation. The EPA has a multi-step data verification process for GHGRP subpart W data, including automatic checks during data entry, statistical analyses on completed reports, and staff review of the reported data. Based on the results of the verification process, the EPA follows up with

facilities to resolve mistakes that may have occurred.

¹⁰¹ Other sources include rice cultivation, stationary combustion, abandoned coal mines, mobile combustion, composting, and several sources emitting less than 1 MMT CO₂ Eq. in 2021.

TABLE 8—U.S. METHANE EMISSIONS FROM NATURAL GAS AND PETROLEUM SYSTEMS—Continued
[MMT CO₂ Eq.]

Sector	1990	2010	2021
Petroleum Production	50	54	49

Emissions from the Inventory of United States Greenhouse Gas Emissions and Sinks: 1990–2021 (published April 13, 2023), calculated using GWP of 28. Note: Totals may not sum due to rounding.

b. Global GHG Emissions

For additional background information and context, we used 2018 World Resources Institute Climate Watch data to make comparisons between U.S. oil and natural gas production and natural gas processing and transmission and storage emissions and the emissions inventories of entire countries and regions.¹⁰² The U.S. methane emissions from oil and natural gas production and natural gas processing and transmission and storage constitute 0.4 percent of total global emissions of all GHGs (48,600 MMT CO₂ Eq.) from all sources.¹⁰³ Ranking U.S. emissions of methane from oil and natural gas production and natural gas processing and transmission and storage against total GHG emissions for entire countries (using 2021 Climate Watch data) shows that these emissions are comparatively large as they exceed the national-level emissions totals for all GHGs and all anthropogenic sources for Colombia, the Czech Republic, Chile, Belgium, and over 164 other countries. This means that the U.S. emits more of a single GHG—methane—from a single sector—the oil and natural gas sector—than the total combined GHGs emitted by 168 countries. Furthermore, U.S. emissions of methane from oil and natural gas production and natural gas processing and transmission and storage are greater than the sum of total emissions of 63 of the lowest-emitting countries and territories using the 2021 Climate Watch data set.

As illustrated by the domestic and global GHGs comparison data summarized above, the collective GHG emissions from the Crude Oil and

Natural Gas source category are significant, whether the comparison is domestic (where this sector is the largest source of methane emissions, accounting for 28 percent of U.S. methane and 3 percent of total U.S. emissions of all GHGs), global (where this sector, accounting for 0.4 percent of all global GHG emissions, emits more than the total national emissions of over 160 countries, and combined emissions of over 60 countries), or when both the domestic and global GHG emissions comparisons are viewed in combination. Consideration of the global context is important. GHG emissions from U.S. oil and natural gas production and natural gas processing and transmission and storage will become globally well-mixed in the atmosphere and thus will have an effect on both the U.S. regional and global climate for years and indeed many decades to come. No single GHG source category dominates on the global scale. While the Crude Oil and Natural Gas source category, like many (if not all) individual GHG source categories, could appear small in comparison to total emissions, in fact, it is a very important contributor both in terms of absolute emissions and in comparison to other source categories globally or within the U.S.

The IPCC AR6 assessment determined that “[f]rom a physical science perspective, limiting human-induced global warming to a specific level requires limiting cumulative CO₂ emissions, reaching at least net zero CO₂ emissions, along with strong reductions in other GHG emissions.” The report also singled out the importance of “strong and sustained methane emission

reductions” in part due to the short lifetime of methane leading to the near-term cooling from reductions in methane emissions, which can offset the warming that will result due to reductions in emissions of cooling aerosols such as SO₂. Therefore, reducing methane emissions globally is an important facet in any strategy to limit warming. In the oil and gas sector, methane reductions are highly achievable and cost-effective using existing and well-known solutions and technologies that actually result in recovery of saleable product.

c. VOC and SO₂ Emissions in the U.S. and From the Oil and Natural Gas Industry

Official U.S. estimates of national-level VOC and SO₂ emissions are developed by the EPA for the National Emissions Inventory (NEI), for which states are required to submit information under 40 CFR part 51, subpart A. Data in the NEI may be organized by various data categories, including sector, NAICS code, and Source Classification Code. Tables 9 and 10 below present total U.S. VOC and SO₂ emissions by sector, respectively, for the year 2020, in kilotons (kt) (or thousand metric tons). The oil and natural gas sector represents the top anthropogenic U.S. sector for VOC emissions after removing the biogenics and wildfire sectors in table 9 (about 23 percent of the total VOC emitting by anthropogenic sources). About 10 percent of the total U.S. anthropogenic SO₂ comes from the oil and natural gas sector.

TABLE 9—U.S. VOC EMISSIONS BY SECTOR
[kt]

Sector	2020 NEI
Biogenics—Vegetation and Soil	29,519
Fires—Wildfires	4,623
Oil and Natural Gas Production, and Natural Gas Processing and Transmission	2,761
Solvent—Consumer and Commercial Solvent Use	1,936
Fires—Prescribed Fires	1,936

¹⁰² The Climate Watch figures presented here come from the PIK dataset included on Climate Watch. The PIK dataset combines the United Nations Framework Convention on Climate Change (UNFCCC) reported data where available and fills

gaps with other sources. It does not include land use change and forestry but covers all other sectors. https://www.climatewatchdata.org/ghg-emissions?end_year=2018&source=PIK&start_year=1990. The PIK data set uses AR4 GWPs. For

the comparisons presented here, the AR4 GWPs were applied to the U.S. oil and gas methane values.

TABLE 9—U.S. VOC EMISSIONS BY SECTOR—Continued
[kt]

Sector	2020 NEI
Mobile—Non-Road Equipment—Gasoline	935
Mobile—On-Road non-Diesel Light Duty Vehicles	835
Other VOC Sources	3,642
Total VOC Emissions	46,188

Emissions from the 2020 NEI (released March 2023). Note: Totals may not sum due to rounding.

TABLE 10—U.S. SO₂ EMISSIONS BY SECTOR
[kt]

Sector	2020 NEI
Fuel Combustion—Electric Generation—Coal	771
Industrial Processes—Not Elsewhere Classified	230
Oil and Natural Gas Production and Natural Gas Processing and Transmission	165
Fires—Wildfires	141
Fuel Combustion—Industrial Boilers, Internal Combustion Engines—Coal	115
Industrial Processes—Chemical Manufacturing	91
Other SO ₂ Sources	313
Total SO₂ Emissions	1,827

Emissions from the 2020 NEI (released March 2023). Note: Totals may not sum due to rounding.

Table 11 presents total VOC and SO₂ emissions from oil and natural gas production through transmission and storage, for the year 2020, in kt. The contribution to the total anthropogenic VOC emissions budget from the oil and

gas sector has been increasing in recent NEI cycles. In the 2020 NEI, the oil and gas sector makes up about 23 percent of the total VOC emissions from anthropogenic sources. The SO₂ emissions have been declining in almost

every anthropogenic sector, but the oil and gas sector is an exception where SO₂ emissions have been increasing in recent years.

TABLE 11—U.S. VOC AND SO₂ EMISSIONS FROM NATURAL GAS AND PETROLEUM SYSTEMS
[kt]

Sector	VOC	SO ₂
Oil and Natural Gas Production	2,729	160
Natural Gas Processing	8	3
Natural Gas Transmission and Storage	24	2

Emissions from the 2020 NEI, (published March 2023), in kt (or thousand metric tons). Note: Totals may not sum due to rounding.

IV. Statutory Background and Regulatory History

A. Statutory Background of CAA Sections 111(b), 111(d), and General Implementing Regulations

The EPA’s authority for this rulemaking is CAA section 111, which governs the establishment of standards of performance for stationary sources. This CAA section requires the EPA to list source categories to be regulated, establish standards of performance for air pollutants emitted by new sources in that source category, and establish EG for states to establish standards of performance for certain pollutants emitted by existing sources in that source category.

Specifically, CAA section 111(b)(1)(A) requires that a source category be included on the list for regulation if, “in

[the EPA Administrator’s] judgment it causes, or contributes significantly to, air pollution which may reasonably be anticipated to endanger public health or welfare.” This determination is commonly referred to as an “endangerment finding” and that phrase encompasses both the “causes or contributes significantly to” component and the “endanger public health or welfare” component of the determination. Once a source category is listed, CAA section 111(b)(1)(B) requires that the EPA propose and then promulgate “standards of performance” for new sources in such source category. CAA section 111(a)(1) defines a “standard of performance” as “a standard for emissions of air pollutants which reflects the degree of emission limitation achievable through the application of the best system of

emission reduction which (taking into account the cost of achieving such reduction and any nonair quality health and environmental impact and energy requirements) the Administrator determines has been adequately demonstrated.” As long recognized by the D.C. Circuit, “[b]ecause Congress did not assign the specific weight the Administrator should accord each of these factors, the Administrator is free to exercise his discretion in this area.” *New York v. Reilly*, 969 F.2d 1147, 1150 (D.C. Cir. 1992). *See also Lignite Energy Council v. EPA*, 198 F.3d 930, 933 (D.C. Cir. 1999) (“*Lignite Energy Council*”) (“Because section 111 does not set forth the weight that be [sic] should assigned to each of these factors, we have granted the Agency a great degree of discretion in balancing them”).

In determining whether a given system of emission reduction qualifies as “the best system of emission reduction . . . adequately demonstrated,” or “BSER,” CAA section 111(a)(1) requires that the EPA take into account, among other factors, “the cost of achieving such reduction.” As described in the proposal¹⁰⁴ for the 2016 Rule and in the November 2021 Proposal for this rulemaking,¹⁰⁵ the U.S. Court of Appeals for the District of Columbia Circuit (the D.C. Circuit) has stated that in light of this provision, the EPA may not adopt a standard the cost of which would be “exorbitant,”¹⁰⁶ “greater than the industry could bear and survive,”¹⁰⁷ “excessive,”¹⁰⁸ or “unreasonable.”¹⁰⁹ These formulations appear to be synonymous, and for convenience, in this rulemaking, as in previous rulemakings, we will refer to this standard as reasonableness, so that a control technology may be considered the “best system of emission reduction . . . adequately demonstrated” if its costs are reasonable, but cannot be considered the BSER if its costs are unreasonable. See 80 FR 64662, 64720–21 (October 23, 2015).

CAA section 111(a) does not provide specific direction regarding what metric or metrics to use in considering costs, affording the EPA considerable discretion in choosing a means of cost consideration.¹¹⁰ In this rulemaking, we evaluated whether a control cost is reasonable under a number of approaches that we find appropriate for assessing the types of controls at issue. For example, we evaluated costs at a sector level by assessing the projected new capital expenditures required under the final rulemaking (compared to overall new capital expenditures by the sector) and the projected compliance costs (compared to overall annual revenue for the sector) if the rule were to require such controls. In evaluating controls for reducing VOC and methane emissions from new sources, we also considered a control’s cost effectiveness under both a “single-pollutant cost effectiveness” approach and a “multipollutant cost effectiveness” approach, in order to appropriately take into account that the systems of

emission reduction considered in this rule typically achieve reductions in multiple pollutants at once and secure a multiplicity of climate and public health benefits.¹¹¹ For a detailed discussion of these cost approaches, please see section VIII.B of the preamble as well as the November 2021 Proposal and the December 2022 Supplemental Proposal.

Under CAA section 111(a)(1), an essential, although not sufficient, condition for a “system of emission reduction” to serve as the basis for an “achievable” emission limitation is that the Administrator must determine that the system is “adequately demonstrated.” This means, according to the D.C. Circuit, that the system is “one which has been shown to be reasonably reliable, reasonably efficient, and which can reasonably be expected to serve the interests of pollution control without becoming exorbitantly costly in an economic or environmental way.”¹¹² It does not mean that the system “must be in actual routine use somewhere,”¹¹³ though the technologies relied upon in this final rulemaking are. Similarly, the EPA may “hold the industry to a standard of improved design and operational advances, so long as there is substantial evidence that such improvements are feasible.”¹¹⁴ Ultimately, the analysis “is partially dependent on ‘lead time,’” that is, “the time in which the technology will have to be available.”¹¹⁵ The caselaw is clear that the EPA may treat a set of control measures as “adequately demonstrated” regardless of whether the measures are in widespread commercial use. For example, the D.C. Circuit upheld the EPA’s determination that selective catalytic reduction (SCR) was adequately demonstrated to reduce NO_x emissions from coal-fired industrial boilers, even though it was a “new

technology.” The court explained that “section 111 ‘looks toward what may fairly be projected for the regulated future, rather than the state of the art at present.’”¹¹⁶ The court added that the EPA may determine that control measures are “adequately demonstrated” through a “reasonable extrapolation of [the control measures’] performance in other industries.”¹¹⁷

As defined in CAA section 111(a), the “standard of performance” that the EPA develops, based on the BSER, is expressed as a performance level (typically, a rate-based standard). CAA section 111(b)(5) precludes the EPA from prescribing a particular technological system that must be used to comply with a standard of performance. Rather, sources can select any measure or combination of measures that will achieve the standard.

CAA section 111(h)(1) authorizes the Administrator to promulgate “a design, equipment, work practice, or operational standard, or combination thereof” if in his or her judgment, “it is not feasible to prescribe or enforce a standard of performance.” CAA section 111(h)(2) provides the circumstances under which prescribing or enforcing a standard of performance is “not feasible,” such as when the pollutant cannot be emitted through a conveyance designed to emit or capture the pollutant, or when there is no practicable measurement methodology for the particular class of sources.¹¹⁸ CAA section 111(b)(1)(B) requires the EPA to “at least every 8 years review and, if appropriate, revise” performance standards unless the “Administrator determines that such review is not appropriate in light of readily available information on the efficacy” of the standard.

As mentioned above, once the EPA lists a source category under CAA section 111(b)(1)(A), CAA section 111(b)(1)(B) provides the EPA discretion to determine the pollutants and sources to be regulated. In addition, concurrent

¹¹¹ We believe that both the single and multipollutant approaches are appropriate for assessing the reasonableness of the multipollutant controls considered in this action. The EPA has considered similar approaches in the past when considering multiple pollutants that are controlled by a given control option. See, e.g., 80 FR 56616–17; 73 FR 64079–83; and EPA Document ID Nos. EPA–HQ–OAR–2004–0022–0622, –0447, –0448.

¹¹² *Essex Chem. Corp. v. Ruckelshaus*, 486 F.2d 427, 433 (D.C. Cir. 1973), cert. denied, 416 U.S. 969 (1974).

¹¹³ *Portland Cement Ass’n v. Ruckelshaus*, 486 F.2d 375, 391 (D.C. Cir. 1973) (citations omitted) (“The Administrator may make a projection based on existing technology, though that projection is subject to the restraints of reasonableness and cannot be based on ‘crystal ball’ inquiry.”); *ibid.* (discussing the Senate and House bills and reports from which the language in CAA section 111 grew).

¹¹⁴ *Sierra Club v. Costle*, 657 F.2d 298, 364 (D.C. Cir. 1981).

¹¹⁵ *Portland Cement Ass’n v. Ruckelshaus*, 486 F.2d 375, 391 (D.C. Cir. 1973) (citations omitted).

¹¹⁶ *Lignite Energy Council*, 198 F.3d at 934 (citing *Portland Cement Ass’n v. Ruckelshaus*, 486 F.2d 375, 391 (D.C. Cir. 1973)).

¹¹⁷ *Id.*

¹¹⁸ The EPA notes that design, equipment, work practice, or operational standards established under CAA section 111(h) (commonly referred to as “work practice standards”) reflect the “best technological system of continuous emission reduction” and that this phrasing differs from the “best system of emission reduction” phrase in the definition of “standard of performance” in CAA section 111(a)(1). Although the differences in these phrases may be meaningful in other contexts, for purposes of evaluating the sources and systems of emission reduction at issue in this rulemaking, the EPA has applied these concepts in an essentially comparable manner because the systems of emission reduction the EPA evaluated are all technological.

¹⁰⁴ 80 FR 56593, 56616 (September 18, 2015).

¹⁰⁵ 86 FR 63154 (December 6, 2022).

¹⁰⁶ *Lignite Energy Council*, 198 F.3d at 933.

¹⁰⁷ *Portland Cement Ass’n v. EPA*, 513 F.2d 506, 508 (D.C. Cir. 1975).

¹⁰⁸ *Sierra Club v. Costle*, 657 F.2d 298, 343 (D.C. Cir. 1981).

¹⁰⁹ *Id.*

¹¹⁰ See, e.g., *Husqvarna AB v. EPA*, 254 F.3d 195, 200 (D.C. Cir. 2001) (where CAA section 213 does not mandate a specific method of cost analysis, the EPA may make a reasoned choice as to how to analyze costs).

with the 8-year review (and though not a mandatory part of the 8-year review), the EPA may examine whether to add standards for pollutants or emission sources not currently regulated for that source category.

Once the EPA establishes NSPS in a particular source category, the EPA is required in certain circumstances to issue EG to reduce emissions from existing sources in that same source category. Specifically, CAA section 111(d) requires that the EPA prescribe regulations to establish procedures under which states submit plans to establish, implement, and enforce standards of performance for existing sources for certain air pollutants to which a Federal NSPS would apply if such existing source were a new source. The EPA addresses this CAA requirement both through its promulgation of general implementing regulations for CAA section 111(d) as well as through specific EG. The EPA first published general implementing regulations in 1975, 40 FR 53340 (November 17, 1975) (codified at 40 CFR part 60, subpart B), and has revised its CAA section 111(d) implementing regulations several times. On the EPA published updated implementing regulations in 2019, 84 FR 32520 (codified at 40 CFR part 60, subpart Ba), which apply to EG promulgated after July 8, 2019, 40 CFR 60.20a(a), including this EG, and which were recently revised.¹¹⁹ In accordance with CAA section 111(d), states are required to submit plans pursuant to these regulations to establish standards of performance for existing sources for any air pollutant: (1) the emission of which is subject to a Federal NSPS; and (2) which is neither a pollutant regulated under CAA section 108(a) (*i.e.*, criteria pollutants such as ground-level ozone and particulate matter (PM), and their precursors, like VOC)¹²⁰ nor a HAP regulated under CAA section 112. See also definition of “designated pollutant” in 40 CFR 60.21a(a). The EPA’s general implementing regulations use the term

¹¹⁹ The D.C. Circuit vacated certain timing provisions within subpart Ba. *American Lung Ass’n*, 985 F.3d 914. However, the court did not vacate the applicability provision. Therefore, 40 CFR part 60, subpart Ba, applies to the final EG. On November 17, 2023, the EPA issued final updates to the Agency’s “Implementing Regulations” under section 111(d) of the Clean Air Act (88 FR 80480). These final amendments address the provisions that were vacated in 2021 and make other updates to the implementing regulations applicable to this EG.

¹²⁰ VOC are not listed as CAA section 108(a) pollutants, but they are regulated precursors to photochemical oxidants (*e.g.*, ozone), which is a listed CAA section 108(a) pollutant. Therefore, VOC falls within the CAA 108(a) exclusion. Accordingly, promulgation of NSPS for VOC does not trigger the application of CAA section 111(d).

“designated facility” to identify those existing sources that may be subject to regulation under the provision of CAA section 111(d). See 40 CFR 60.21a(b).

While states are authorized to establish standards of performance for designated facilities, there is a fundamental requirement under CAA section 111(d) that a state’s standards of performance in its state plan submittal are no less stringent than the presumptive standard determined by the EPA, which derives from the definition of “standard of performance” in CAA section 111(a)(1). The EPA identifies the degree of emission limitation achievable through application of the BSER as part of its EG. See 40 CFR 60.22a(b)(5). While standards of performance must generally reflect the degree of emission limitation achievable through application of the BSER, CAA section 111(d)(1) also requires that the EPA regulations permit the states, in applying a standard of performance to a particular source, to take into account the source’s RULOF. States may apply less stringent standards of performance to particular sources based on consideration of such sources’ remaining useful life and other factors.

After the EPA issues final EG per the requirements under CAA section 111(d) and under 40 CFR part 60, subpart Ba, states are required to submit to the EPA plans that establish standards of performance for the designated facilities as defined in the EPA’s guidelines and that contain other measures to implement and enforce those standards. The EPA’s final EG issued under CAA section 111(d) do not impose binding requirements directly on sources but instead provide requirements for states in developing their plans and criteria for assisting the EPA when judging the adequacy of such plans. Under CAA section 111(d), and the EPA’s implementing regulations, a state must submit its plan to the EPA for approval; the EPA will evaluate the plan for completeness in accordance with enumerated criteria and then will act on that plan via a rulemaking process to either approve or disapprove the plan in whole or in part. If a state does not submit a plan, or if the EPA does not approve a state’s plan because it is not “satisfactory,” then the EPA must establish a Federal plan for designated facilities in that state.¹²¹ If the EPA approves a state’s plan, the provisions in the state plan become federally enforceable against the designated facility responsible for compliance in the same manner as the provisions of an

¹²¹ CAA section 111(d)(2)(A).

approved State Implementation Plan (SIP) under CAA section 110. If no designated facility is located within a state, the state must submit to the EPA a letter certifying to that effect in lieu of submitting a state plan. See 40 CFR 60.23a(b).

Designated facilities located in Indian country would not be addressed by a state’s CAA section 111(d) plan. Instead, an eligible Tribe that has one or more designated facilities located in its area of Indian country¹²² would have the opportunity, but not the obligation, to seek authority and submit a plan that establishes standards of performance for those facilities on its Tribal lands.¹²³ If a Tribe does not submit a plan, or if the EPA does not approve a Tribe’s plan, then the EPA has the authority to establish a Federal plan for the designated facilities located on its Tribal land.¹²⁴

B. What is the regulatory history and litigation background of NSPS and EG for the oil and natural gas industry?

1. 1979 Listing of Source Category

Subsequent to the enactment of the CAA of 1970, the EPA took action to develop standards of performance for new stationary sources as directed by Congress in CAA section 111. By 1977, the EPA had promulgated NSPS for a total of 27 source categories, while NSPS for an additional 25 source categories were then under development.¹²⁵ However, in amending the CAA that year, Congress expressed dissatisfaction that the EPA’s pace was too slow. Accordingly, the 1977 CAA Amendments included a new subsection (f) in section 111, which specified a schedule for the EPA to list additional source categories under CAA section 111(b)(1)(A) and prioritize them for regulation under CAA section 111(b)(1)(B).

In 1979, as required by CAA section 111(f), the EPA published a list of source categories, which included “*Crude Oil and Natural Gas Production*,” for which the EPA would promulgate standards of performance under CAA section 111(b). See “Priority List and Additions to the List of Categories of Stationary Sources,” 44 FR 49222 (August 21, 1979) (“1979 Priority List”). That list included, in the order of priority for promulgating standards, source categories that the EPA Administrator had determined, pursuant to CAA section 111(b)(1)(A),

¹²² The EPA is aware of many oil and natural gas operations located in Indian country.

¹²³ See 40 CFR part 49, subpart A.

¹²⁴ CAA section 111(d)(2)(A).

¹²⁵ See 44 FR 49222 (August 21, 1979).

contribute significantly to air pollution that may reasonably be anticipated to endanger public health or welfare. See 44 FR 49223 (August 21, 1979); see also 49 FR 2636–37 (January 20, 1984).

2. 1985 NSPS for VOC and SO₂ Emissions From Natural Gas Processing Plants

On June 24, 1985 (50 FR 26122), the EPA promulgated NSPS for the Crude Oil and Natural Gas source category that addressed VOC emissions from equipment leaks at onshore natural gas processing plants (40 CFR part 60, subpart KKK). On October 1, 1985 (50 FR 40158), the EPA promulgated additional NSPS for the source category to regulate SO₂ emissions from onshore natural gas processing plants (40 CFR part 60, subpart LLL).

3. 2012 NSPS OOOO Rule and Related Amendments

In 2012, pursuant to its duty under CAA section 111(b)(1)(B) to review and, if appropriate, revise the 1985 NSPS, the EPA published the final rule, “Standards of Performance for Crude Oil and Natural Gas Production, Transmission and Distribution,” 77 FR 49490 (August 16, 2012) (40 CFR part 60, subpart OOOO) (“2012 NSPS OOOO”). The 2012 rule updated the SO₂ standards for sweetening units and the VOC standards for equipment leaks at onshore natural gas processing plants. In addition, it established VOC standards for several oil and natural gas-related operations emission sources not covered by 40 CFR part 60, subparts KKK and LLL, including natural gas well completions, centrifugal and reciprocating compressors, certain natural gas-driven process controllers in the production and processing segments of the industry, and storage vessels in the production, processing, and transmission and storage segments.

In 2013, 2014, and 2015 the EPA amended the 2012 NSPS OOOO rule in order to address implementation of the standards. “Oil and Natural Gas Sector: Reconsideration of Certain Provisions of New Source Performance Standards,” 78 FR 58416 (September 23, 2013) (“2013 NSPS OOOO”) (concerning storage vessel implementation); “Oil and Natural Gas Sector: Reconsideration of Additional Provisions of New Source Performance Standards,” 79 FR 79018 (December 31, 2014) (“2014 NSPS OOOO”) (concerning well completion); “Oil and Natural Gas Sector: Definitions of Low Pressure Gas Well and Storage Vessel,” 80 FR 48262 (August 12, 2015) (“2015 NSPS OOOO”) (concerning low-pressure gas wells and storage vessels).

The EPA received petitions for both judicial review and administrative reconsiderations for the 2012, 2013, and 2014 NSPS OOOO rules. The EPA denied reconsideration for some issues, see “Reconsideration of the Oil and Natural Gas Sector: New Source Performance Standards; Final Action,” 81 FR 52778 (August 10, 2016), and, as noted below, granted reconsideration for other issues. As explained below, all litigation related to NSPS OOOO is currently in abeyance.

4. 2016 NSPS OOOOa Rule and Related Amendments

a. Regulatory Action

On June 3, 2016, the EPA published a final rule titled, “Oil and Natural Gas Sector: Emission Standards for New, Reconstructed, and Modified Sources; Final Rule,” at 81 FR 35824 (40 CFR part 60, subpart OOOOa) (“2016 Rule” or “2016 NSPS OOOOa”).^{126 127} The 2016 NSPS OOOOa rule established NSPS for sources of GHGs and VOC emissions for certain equipment, processes, and operations across the oil and natural gas industry, including in the transmission and storage segment (81 FR 35832). The EPA explained that the 1979 listing identified the source category broadly enough to include that segment and, in the alternative, if the listing had limited the source category to the production and processing segments, the EPA affirmatively expanded the source category to include the transmission and storage segment on grounds that operations in those segments are a sequence of functions that are interrelated and necessary for getting the recovered gas ready for distribution (81 FR 35832). In addition, because the 2016 rule represented the first time that the EPA had promulgated NSPS for GHG emissions from the Crude Oil and Natural Gas source category, the EPA predicated those NSPS on a determination that it had a rational basis on which to regulate GHG emissions from the source category (81 FR 35843). In response to comments, the

¹²⁶ The June 3, 2016, rulemaking also included certain final amendments to 40 CFR part 60, subpart OOOO, to address issues on which the EPA had granted reconsideration.

¹²⁷ The EPA review which resulted in the 2016 NSPS OOOOa rule was instigated by a series of directives from then-President Obama targeted at reducing GHGs, including methane: the President’s *Climate Action Plan* (June 2013); the President’s *Climate Action Plan: Strategy to Reduce Methane Emissions* (“Methane Strategy”) (March 2014); and the President’s goal to address, propose and set standards for methane and ozone-forming emissions from new and modified sources in the sector (January 2015, <https://obamawhitehouse.archives.gov/the-press-office/2015/01/14/fact-sheet-administration-takes-steps-forward-climate-action-plan-anno-1>).

EPA explained that it was not required to make an additional pollutant-specific finding that GHG emissions from the source category contribute significantly to dangerous air pollution, but in the alternative, the EPA did make such a finding, relying on the same information that it relied on when determining that it had a rational basis on which to promulgate a GHG NSPS (81 FR 35843).

Specifically, the 2016 NSPS OOOOa addresses the following emission sources:

- Sources that were unregulated under the 2012 NSPS OOOO (hydraulically fractured oil well completions, pneumatic pumps, and fugitive emissions from well sites and compressor stations);
- Sources that were regulated under the 2012 NSPS OOOO for VOC emissions, but not for GHG emissions (hydraulically fractured gas well completions and equipment leaks at natural gas processing plants); and
- Certain equipment that is used across the source category, of which the 2012 NSPS OOOO regulated emissions of VOC from only a subset (process controllers, centrifugal compressors, and reciprocating compressors, with the exception of those compressors located at well sites).

On March 12, 2018 (83 FR 10628), the EPA finalized amendments to certain aspects of the 2016 NSPS OOOOa requirements for the collection of fugitive emissions components at well sites and compressor stations, specifically (1) the requirement that components on a delay of repair must conduct repairs during unscheduled or emergency vent blowdowns, and (2) the monitoring survey requirements for well sites located on the Alaska North Slope.

b. Petitions for Judicial Review and To Reconsider

Following promulgation of the 2016 NSPS OOOOa rule, several states and industry associations challenged the final rule in the D.C. Circuit. The Administrator also received five petitions for reconsideration of several provisions of the final rule. Copies of the petitions are posted in Docket ID No. EPA–HQ–OAR–2010–0505.¹²⁸ As noted below, the EPA granted reconsideration as to several issues raised with respect to the 2016 NSPS OOOOa rule and finalized certain modifications discussed in the next section of this document. As explained in the next section, all litigation challenging the

¹²⁸ See Document ID Nos. EPA–HQ–OAR–2010–0505–7682, –7683, –7684, –7685, –7686.

2016 NSPS OOOOa rule is currently stayed.

5. 2020 Policy and Technical Rules

a. Regulatory Action

In September 2020, the EPA published two final rules to amend 2012 NSPS OOOO and 2016 NSPS OOOOa. The first is titled, “Oil and Natural Gas Sector: Emission Standards for New, Reconstructed, and Modified Sources Review.” 85 FR 57018 (September 14, 2020). Commonly referred to as the 2020 Policy Rule, it first rescinded the regulations applicable to the transmission and storage segment on the basis that the 1979 listing limited the source category to the production and processing segments and that the transmission and storage segment is not “sufficiently related” to the production and processing segments and therefore cannot be part of the same source category (85 FR 57027, 57029). In addition, the 2020 Policy Rule rescinded methane requirements for the industry’s production and processing segments on two separate bases. The first was that such standards are redundant to VOC standards for these segments (85 FR 57030). The second was that the rule interpreted CAA section 111 to require, or at least authorize the Administrator to require, a pollutant-specific “significant contribution finding” (SCF) as a prerequisite to a NSPS for a pollutant, and to require that such finding be supported by some identified standard or established set of criteria for determining which contributions are “significant” (85 FR 57034). The 2020 Policy Rule went on to conclude that the alternative significant-contribution finding that the EPA made in the 2016 Rule for GHG emissions was flawed because it accounted for emissions from the transmission and storage segment and because it was not supported by criteria or a threshold (85 FR 57038).¹²⁹

Published on September 15, 2020, the second of the two rules is titled, “Oil and Natural Gas Sector: Emission Standards for New, Reconstructed, and Modified Sources Reconsideration.” Commonly referred to as the 2020 Technical Rule, this second rule made

further amendments to the 2016 NSPS OOOOa following the 2020 Policy Rule to eliminate or reduce certain monitoring obligations and to address a range of issues in response to administrative petitions for reconsideration and other technical and implementation issues brought to the EPA’s attention since the 2016 NSPS OOOOa rulemaking. Specifically, the 2020 Technical Rule exempted low production well sites from fugitives monitoring (previously required semiannually), required semiannual monitoring at gathering and boosting compressor stations (previously quarterly), streamlined recordkeeping and reporting requirements, allowed compliance with certain equivalent state requirements as an alternative to NSPS fugitive requirements, streamlined the application process to request the use of new technologies to monitor for fugitive emissions, addressed storage tank batteries for applicability determination purposes and finalized several technical corrections. Because the 2020 Technical Rule was issued the day after the EPA’s rescission of methane regulations in the 2020 Policy Rule, the amendments made in the 2020 Technical Rule applied only to the requirements to regulate VOC emissions from this source category. The 2020 Policy Rule amended 40 CFR part 60, subparts OOOO and OOOOa, as finalized in 2016. The 2020 Technical Rule amended the 40 CFR part 60, subpart OOOOa, as amended by the 2020 Policy Rule.

b. Petitions To Reconsider

The EPA received three petitions for reconsideration of the 2020 rulemakings. Two of the petitions sought reconsideration of the 2020 Policy Rule. As discussed below, on June 30, 2021, the President signed into law S.J. Res. 14, a joint resolution under the CRA disapproving the 2020 Policy Rule, and as a result, the petitions for reconsideration on the 2020 Policy Rule are now moot. All three petitions sought reconsideration of certain elements of the 2020 Technical Rule.

c. Litigation

Several states and non-governmental organizations (NGOs) challenged the 2020 Policy Rule as well as the 2020 Technical Rule. All petitions for review regarding the 2020 Policy Rule were consolidated into one case in the D.C. Circuit. *State of California, et al. v. EPA*, No. 20–1357. On August 25, 2021, after the enactment of the joint resolution of Congress disapproving the 2020 Policy Rule (explained in section VIII of this preamble), the U.S. Court of Appeals for

the District of Columbia Circuit (*i.e.*, the court) granted petitioners’ motion to voluntarily dismiss their cases. *Id.* ECF Docket #1911437. All petitions for review regarding the 2020 Technical Rule were consolidated into a different case in the D.C. Circuit. *Environmental Defense Fund (EDF), et al. v. EPA*, No. 20–1360 (D.C. Cir.). On February 19, 2021, the court issued an order granting a motion by the EPA to hold in abeyance the consolidated litigation over the 2020 Technical Rule pending the EPA’s rulemaking actions in response to E.O. 13990 and pending the conclusion of the EPA’s potential reconsideration of the 2020 Technical Rule. *Id.* ECF Docket #1886335.

As mentioned above, the EPA received petitions for judicial review regarding the 2012, 2013, and 2014 NSPS OOOO rules as well as the 2016 NSPS OOOOa rule. The challenges to the 2012 NSPS OOOO rule (as amended by the 2013 NSPS OOOO and 2014 NSPS OOOO rules) were consolidated. *American Petroleum Institute v. EPA*, No. 13–1108 (D.C. Cir.). The majority of those cases were further consolidated with the consolidated challenges to the 2016 NSPS OOOOa rule. *West Virginia v. EPA*, No. 16–1264 (D.C. Cir.), see specifically ECF Docket #1654072. As such, *West Virginia v. EPA* includes challenges to the 2012 NSPS OOOO rule (as amended by the 2013 NSPS OOOO and 2014 NSPS OOOO rules) as well as challenges to the 2016 NSPS OOOOa rule.¹³⁰ On December 10, 2020, the court granted a joint motion of the parties in *West Virginia v. EPA* to hold that case in abeyance until after the mandate has issued in the case regarding challenges to the 2020 Technical Rule. *West Virginia v. EPA*, ECF Docket #1875192.

C. Congressional Review Act (CRA) Joint Resolution of Disapproval

On June 30, 2021, the President signed into law a joint resolution of Congress, S.J. Res. 14, adopted under the CRA,¹³¹ disapproving the 2020 Policy Rule.¹³² By the terms of the CRA, the signing into law of the CRA joint resolution of disapproval means that the

¹²⁹ Following the promulgation of the 2020 Policy Rule, the EPA promulgated a final rule that identified a standard or criteria for determining which contributions are “significant,” which the D.C. Circuit vacated. “Pollutant-Specific Significant Contribution Finding for Greenhouse Gas Emissions From New, Modified, and Reconstructed Stationary Sources: Electric Utility Generating Units, and Process for Determining Significance of Other New Source Performance Standards Source Categories.” 86 FR 2542 (January 13, 2021), vacated by *California v. EPA*, No. 21–1035 (D.C. Cir.) (Order, April 5, 2021, Doc. #1893155).

¹³⁰ When the EPA issued the 2016 NSPS OOOOa rule, a challenge to the 2012 NSPS OOOO rule for failing to regulate methane was severed and assigned to a separate case, *NRDC v. EPA*, No. 16–1425 (D.C. Cir.), pending judicial review of the 2016 NSPS OOOOa in *American Petroleum Institute v. EPA*, No. 13–1108 (D.C. Cir.).

¹³¹ The Congressional Review Act was adopted in Subtitle E of the Small Business Regulatory Enforcement Fairness Act of 1996.

¹³² “Oil and Natural Gas Sector: Emission Standards for New, Reconstructed, and Modified Sources Review.” 85 FR 57018 (September 14, 2020) (“2020 Policy Rule”).

2020 Policy Rule is “treated as though [it] had never taken effect.” 5 U.S.C. 801(f). As a result, the VOC and methane standards for the transmission and storage segment, as well as the methane standards for the production and processing segments—all of which had been rescinded in the 2020 Policy Rule—remain in effect. In addition, the EPA’s authority and obligation to require the states to regulate existing sources of methane in the Crude Oil and Natural Gas source category under section 111(d) of the CAA also remains in effect.

The CRA resolution did not address the 2020 Technical Rule. Therefore, those amendments remain in effect with respect to the VOC standards for the production and processing segments in effect at the time of its enactment. As part of this rulemaking, in section XII of this document the EPA discusses the impact of the CRA resolution and identifies and finalizes appropriate changes to reinstate the regulatory text that had been rescinded by the 2020 Policy Rule and to resolve any discrepancies in the regulatory text between the 2016 NSPS OOOOa Rule and 2020 Technical Rule.¹³³

V. Legal Basis for Final Rule Scope

A. Introduction

The EPA finalizes this rulemaking to revise certain NSPS, to promulgate additional NSPS for both methane and VOC emissions from new oil and gas sources in the production, processing, and transmission and storage segments of the industry; and to promulgate EG to require states to regulate methane emissions from existing sources in those segments. The large amount of methane emissions from the oil and natural gas industry—by far, the largest methane-emitting industry in the nation—coupled with the adverse effects of methane on the global climate compel expeditious regulatory action to mitigate those emissions. This section explains the EPA’s legal authority for proceeding with this final action, including regulating methane and VOCs from sources in all segments of the source category, and in so doing, responds to the principal comments received.

¹³³ The EPA understands that a limited number of affected facilities may have obtained, renewed, or revised a title V permit to reflect the 2020 Policy Rule, and that such permits no longer include certain applicable requirements from the 2012 NSPS OOOO and 2016 NSPS OOOOa regulations that were reinstated by the CRA. The EPA strongly encourages states to reopen Title V permits that currently reflect the 2020 Policy Rule, and to follow all appropriate requirements of 40 CFR 70.7(f) governing the reopening of Title V permits.

In the November 2021 Proposal and the December 2022 Supplemental Proposal, the EPA discussed the history of our regulatory actions for oil and gas sources in the 2016 NSPS OOOOa and the 2020 Policy Rule. See 85 FR 63147–53, 86 FR 74719–20. These discussions explained the key statutory interpretations and determinations, which we sometimes refer to as the key positions, taken in the 2016 rule that serve as the basis for this action, as well as Congress’s endorsement of those positions in adopting the 2021 CRA joint resolution to disapprove the 2020 rule and thereby reinstate the 2016 rule. These discussions further explained that the EPA was not reopening those positions in this rulemaking, but added, for the purpose of informing the public, that the EPA would continue to take the same positions even if Congress had not adopted the joint resolution. The EPA includes those discussions by reference here, and the rest of this section assumes familiarity with them. For convenience, the EPA summarizes them immediately below. The EPA then summarizes the principal comments received and responds to the most significant adverse comments. For the purpose of providing more information to the public, and without reopening the positions in the 2016 rule, the EPA explains why we would take the same positions as in the 2016 rule even if Congress had not adopted the joint resolution as well as the implications of the joint resolution and its legislative history in foreclosing commenters’ objections.

B. Overview

This section summarizes why the statutory interpretations the EPA took in the 2016 Rule were correct and why the contrary interpretations taken in the congressionally-voided 2020 Policy Rule were incorrect.¹³⁴ These views are confirmed by Congress’s reasoning in the legislative history of the CRA resolution and so, for convenience, this section refers to that legislative history as well.

The 2016 NSPS OOOOa established the EPA’s authority to regulate GHG emissions from the Crude Oil and Natural Gas source category, in the form of limits on methane emissions. In that rule, the EPA explained that the source

category, as the EPA listed it in 1979 for regulation under CAA section 111(b)(1)(A), included the production and processing as well as transmission and storage segments. The EPA also explained that it was justified in promulgating standards of performance for GHG emissions from new sources in the source category because it had a rational basis for doing so. In response to comments, the EPA further explained that once it had listed a source category, it was not required to make, as a predicate to regulating GHG emissions from the source category, an additional pollutant-specific finding that those GHG emissions contribute significantly to dangerous air pollution (termed, a pollutant-specific significant contribution finding).

In addition to providing those explanations, the EPA made two determinations in the 2016 NSPS OOOOa that established alternative legal bases for the GHG NSPS. The first was that the EPA re-listed the source category under CAA section 111(b)(1)(A). To do so, the EPA determined the following: (i) In case the source category did not already include the transmission and storage segment, the EPA revised the source category to include that segment, along with the production and processing segments. The EPA explained that all the segments are interrelated because they comprise parts of a single process of extracting natural gas and preparing it for commercial sale, and that many of the same types of equipment are used in the various segments. (ii) By dint of its emissions of VOC, SO₂, and GHG, the source category thus defined “causes or contributes significantly to air pollution which may reasonably be anticipated to endanger public health or welfare,” under CAA section 111(b)(1)(A). 81 FR 25833–40. For convenience, we refer to this as the endangerment finding, and treat it as having two components: the significant contribution finding and the finding of dangerous air pollution. The second determination was that, in the alternative, if it were necessary to make a pollutant-specific significant contribution finding for GHG emissions as a predicate to promulgating NSPS for GHG from the source category, then the 2016 rule made such a finding. To do so, the rule relied on information concerning the large amounts of methane emissions from the source category. 81 FR 35843.

The 2020 Policy Rule rescinded the above statutory interpretations and determinations. 85 FR 57018. The rule asserted that the transmission and storage segment was not properly included as part of the same source

¹³⁴ Under *F.C.C. v. Fox Television Stations, Inc.*, 556 U.S. 502 (2009), an agency may revise its policy, but must demonstrate that the new policy is permissible under the statute and is supported by good reasons, taking into account the record of the previous rule. To the extent that this standard applies in this action—where Congress has disapproved the 2020 Policy Rule—the EPA believes the explanations provided here satisfy the standard.

category as the production and processing segments, and was therefore not subject to regulation under CAA section 111. The rule took the position that the transmission and storage segment had not been included in the source category when it was originally listed in 1979, and the 2016 rule's alternative determination to revise the source category was flawed because that segment was not interrelated with the production and processing segments. The rule further asserted that the EPA did not have authority to promulgate NSPS for methane emissions from sources in the production and processing segments because those NSPS were redundant to NSPS for VOC emissions from those sources. The rule further asserted, in the alternative, that the EPA did not have such authority because it was required to make, or was at least authorized to require, a pollutant-specific significant contribution finding for GHG emissions from production and processing sources as a predicate for promulgating NSPS for methane emissions. The rule explained that such a finding was necessary because the EPA had not considered GHG emissions when it listed the source category in 1979. The rule further asserted that the pollutant-specific significant contribution finding in the 2016 NSPS OOOOa was flawed because it had been based in part on emissions from the transmission and storage segment, which, in the rule's view, were not part of the oil and gas source category, and because the EPA had not first established a standard or criteria for determining when emissions contribute significantly, as opposed to simply contribute, to dangerous air pollution. 85 FR 57024–40.

The CRA joint resolution, signed into law by President Biden on June 30, 2021, disapproved the 2020 Policy Rule, and thereby reinstated the 2016 NSPS OOOOa regulation of sources in the transmission and storage segment and regulation of methane emissions from the entire oil and gas source category. 86 FR 63135–36. The legislative history of the CRA resolution—the House Report and a floor statement from Senate sponsors, 167 Cong. Rec. S2282–83 (April 28, 2021) (statement by Sen. Heinrich) (Senate Statement)—made clear Congress's intent that the EPA must regulate methane from the source category under CAA section 111, due to the large amount and impact of those emissions. The legislative history went on to make clear that Congress's basis for disapproving the 2020 rule was that Congress rejected each of the legal interpretations, described above, that

underlay the rule. Specifically, the legislative history stated that: the rule was incorrect in removing the transmission and storage segment from the source category; promulgation of NSPS for methane was not redundant with promulgation of NSPS for VOCs, in light of the fact that the former, but not the latter, triggers the requirement to promulgate emission guidelines for existing sources under CAA section 111(d); the EPA is required to promulgate NSPS for a pollutant from a source category when the EPA has a rational basis for doing so, and the EPA cannot decline to promulgate a NSPS on grounds that it is required, or authorized to require, a pollutant-specific significant contribution finding; and the EPA's past approach of relying on a facts-and-circumstances approach to determine significance is acceptable, and an established standard or criteria are not necessary.

In the November 2021 Proposal, the EPA confirmed that it agreed with those interpretations. 86 FR 63151. In the December 2022 Supplemental Proposal, the EPA added that if it were required to make a pollutant-specific significant contribution finding, it would not be required to specify a standard or criterion for determining significance, and that if it were so required, methane emissions from the source category are so large that they would be significant under any reasonable standard or criterion. 87 FR 74719–20 (explaining that the “massive quantities of methane emissions” from the source category, combined with the “potency of methane” are significant in light of, among other things, the fact that the oil and gas sector accounts for 28 percent of U.S. methane emissions or more than the total national emissions of over 160 countries).¹³⁵

C. Comments

Some stakeholders commented adversely. They assert that the November 2021 Proposal and the December 2022 Supplemental Proposal contain what they see as the same flaws as the 2016 NSPS OOOOa. One of these flaws, these commenters assert, is that the EPA is precluded from promulgating requirements for sources in the transmission and storage segment without first listing that segment as a separate source category and making an endangerment finding for GHG emissions from it. According to this view, the source category as listed in

1979 did not include that segment, and that segment must be treated as a separate source category because otherwise, the agency could expand a preexisting source category incrementally, and thereby avoid the CAA section 111 requirements to undertake an endangerment finding before promulgating regulation. A second flaw, according to these commenters, is that regulation of methane is redundant to regulation of VOC. In addition, the commenters assert that CAA section 111 precludes the EPA from promulgating requirements for GHG emissions from the source category without first making a pollutant-specific endangerment finding, including a pollutant-specific significant contribution finding. Moreover, according to the commenters, such a finding must be for methane. In addition, it must be based on an established standard or criteria for determining significance; otherwise, such a finding would be arbitrary and capricious. According to these commenters, CAA section 111 does not authorize the EPA to regulate air pollutants from a listed source category on the grounds that it has a rational basis for such regulation. These commenters further assert that although the CRA resolution disapproved the 2020 Policy Rule, it did not change the underlying requirements of CAA section 111, so that these flaws in the EPA's regulatory approach remained. They argue that only the legislative language of the joint resolution, and not the accompanying legislative history, is relevant.

Other commenters supported the November 2021 Proposal and December 2022 Supplemental Proposal. They state that the 2016 NSPS OOOOa established an appropriate basis for promulgating regulations to control methane emissions from the oil and gas industry. They state that the 1979 source category listing included the transmission and storage segment, and that in any event, the 2016 rule correctly determined that the transmission and storage segment was interrelated with the other segments and thus merited inclusion in the revised source category. They also state that regulation of methane from this source category is not redundant to regulation of VOCs. They add that because the EPA previously determined that the oil and gas source category causes or contributes significantly to dangerous air pollution, the EPA is authorized to promulgate a NSPS for methane because it is rational to do so in light of the large amount of methane emissions from the source category. For

¹³⁵ As noted above, to the extent that the standard of *Fox Television* applies in this action—where Congress has disapproved the 2020 Policy Rule—the EPA believes the explanations provided here satisfy the standard.

this reason, commenters assert, it would be arbitrary and capricious for the EPA to decline to regulate methane emissions from the source category. Commenters add that a pollutant-specific significant contribution or endangerment finding for methane is neither necessary nor authorized by CAA section 111; that any such findings under CAA section 111 should be made on the basis of the facts and circumstances, and not a predetermined standard or threshold; and that in any event, the large amounts of methane emissions from the source category must be considered to be significant under any reasonable definition. Commenters also note that the 2016 rule made an appropriate significant finding contribution for GHG from the source category in the alternative. Commenters also assert that Congress's disapproval of the 2020 Policy Rule through the CRA joint resolution reaffirmed the 2016 rule's positions.

D. Response to Comments and Discussion

The adverse arguments by commenters described above concern the positions in the 2016 NSPS OOOOa, which also provide the basis for this rulemaking, and the significance of the CRA joint resolution and its legislative history. The commenters' arguments concerning the positions in the 2016 rule were rejected in the 2016 rule itself, adopted in the 2020 Policy Rule, and then rejected in the legislative history of the joint resolution. The EPA stated in the November 2021 Proposal and December 2022 Supplemental Proposal that it was not reopening these positions, and we maintain that decision here. However, again, solely for the purpose of informing the public, we provide responses to the commenters' arguments immediately below and in the response to comment document. Our decision not to reopen the positions in the 2016 rule does not apply to issues concerning the joint resolution, which post-dated the 2016 rule. Accordingly, the EPA responds in more detail further below to the commenters' arguments concerning the joint resolution.

1. Commenters' Arguments Concerning the Key Positions in the 2016 NSPS OOOOa

Stakeholders submitted adverse comments on key positions, including statutory interpretations and determinations, that the EPA made in the 2016 NSPS OOOOa and that serve as the foundation for the present action. These adverse comments generally mirrored those made in the course of the 2016 NSPS OOOOa rulemaking and the

rationale for the 2020 Policy Rule, and did not raise significant new points not addressed in the 2016 NSPS OOOOa or the November 2021 Proposal and December 2022 Supplemental Proposal. The EPA continues to disagree with those comments.

a. Scope of the Oil and Gas Source Category as Listed in 1979

i. Scope of the Source Category as Listed in 1979

The 2016 NSPS OOOOa stated that the Crude Oil and Natural Gas Production source category, as the EPA listed it for regulation under CAA section 111(b)(1)(A) in 1979, included the transmission and storage segment, along with the other two major segments of the industry, the production and processing segments. Based on this understanding, the EPA continued to promulgate NSPS for sources in that segment, after it had begun to do so in the 2012 NSPS OOOO. Adverse commenters on the November 2021 Proposal took the contrary view, reiterating adverse comments on the 2016 rule. However, the 2016 rule was correct—the EPA's 1979 listing of the source category should be considered to have included the transmission and storage segment.

The commenters' argument stems from the fact that the 1979 listing, 44 FR 49222 (Aug. 21, 1979) (1979 Listing Rule), identified the source category as "Crude Oil and Natural Gas Production," and did not specifically identify the transmission and storage segment as part of the source category. See 44 FR 49222 (citing *Priorities for New Source Performance Standards Under the Clean Air Act Amendments of 1977*, EPA-450/3-78-019 (April 1978) ("1978 Priority List"). This argument fails to recognize the comprehensive approach that the EPA undertook in the 1979 Listing Rule, which strongly indicates that the oil and gas source category included the transmission and storage segment. In the 1979 Listing Rule, the EPA determined that numerous source categories met the CAA section 111(b)(1)(B) requirements to be listed for regulation. The EPA based that determination on a study it had undertaken in 1978, the 1978 Priorities List, that comprehensively identified all source categories in the United States—203 in number—and indicated which ones should and should not be listed. That study identified the oil and gas source category as the "Crude Oil and Natural Gas Production Plants," a name that referenced only the production segment of the oil and gas industry. However, the

study, and the 1979 Listing Rule, which identified the source category as "Crude Oil and Natural Gas Production," clearly intended the source category to be broader than just that segment, consistent with the fact that the 1978 Priorities List was designed to be comprehensive. This is evident because in 1985, the EPA promulgated the first set of NSPS for the source category, which concerned sources in the processing segment, not the production segment. 50 FR 26122 (June 24, 1985) (VOC emissions from equipment leaks), 50 FR 40158 (Oct. 1, 1985) (SO₂ emissions). It is evident that the source category, as listed in 1979, also included the third major segment of the industry, the transmission and storage segment. Otherwise, the 1978 Priorities List, which was designed to be comprehensive, would have completely overlooked this major segment, which is not plausible.

ii. Alternative Determination in 2016 NSPS OOOOa To Include Transmission and Storage Segment in Source Category

In addition, in the 2016 NSPS OOOOa, in the alternative, and on the assumption that the source category as listed in 1979 did not include the transmission and storage segment, the EPA revised the source category to include that segment, and relisted that source category—which it termed the Crude Oil and Natural Gas source category—under CAA section 111(b)(1)(A). 81 FR 35832–40. This alternative determination further addresses commenters' objections.

The EPA has broad discretion in determining the scope of the source category, which is reviewable under the arbitrary and capricious standard of CAA section 307(d)(9). In the 2016 NSPS OOOOa, the EPA determined that the transmission and storage segment was "interrelated" with the production and processing segments and therefore should be included in the same source category, the EPA provided sound reasons for doing so. 81 FR 35832. This reasoning is consistent with the ordinary understanding of the term, "category." Merriam-Webster defines "category" as "any of several fundamental and distinct classes to which entities or concepts belong,"¹³⁶ and it defines a "class []" as "a group, set, or kind sharing common attributes."¹³⁷ Treating all those

¹³⁶ "Category." Merriam-Webster.com Dictionary, Merriam-Webster, <https://www.merriamwebster.com/dictionary/category>. Accessed Sept. 25, 2023.

¹³⁷ "Class." Merriam-Webster.com Dictionary, Merriam-Webster, <https://www.merriamwebster.com/dictionary/class>. Accessed Sept. 25, 2023.

segments as part of the source category meets this definition because, as the EPA explained in the 2016 NSPS OOOOa, the segments all included operations that were a sequence of functions in a multi-step process that is necessary to achieve the common goal of preparing recovered gas for distribution. Moreover, the segments had common equipment and control technology. 81 FR 35832. In the 2016 rule, the EPA went on to assess the air pollutants emitted from the source category, including VOC, SO₂, and GHG; as well as the associated air pollution, including hazardous air pollution, tropospheric ozone, SO₂, and atmospheric GHG; and determined that the source category causes or contributes significantly to air pollution which may reasonably be anticipated to endanger public health or welfare. *Id.* 35840. The EPA has not reopened that endangerment finding.

This re-listing addresses the commenters' objections concerning the regulation of sources in the transmission and storage segment. By properly including the segment in a source category and listing that source category under CAA section 111(b)(1)(A), the EPA established the predicate for such regulation.

b. Reliance on Rational Basis Test, and Rejection of Pollutant-Specific Significant Contribution Finding, for Regulating GHG From the Source Category

In the 2016 NSPS OOOOa, the EPA interpreted CAA section 111 to authorize regulation of methane emissions from the oil and gas source category because the large amount of those emissions provided a rational basis for such regulation. 81 FR 35842. The EPA went on to determine that it had a rational basis to regulate methane emissions from the source category on grounds that, among other things, the oil and gas industry is the largest industrial emitter of methane in the U.S. *Id.* 35842–43. As stated in section III, human emissions of methane, a potent GHG, are responsible for about one third of the warming due to well-mixed GHGs, which makes methane the second most important human warming agent after carbon dioxide.¹³⁸ The EPA has not reopened that determination in the present rulemaking.

However, commenters asserted that under CAA section 111, a rational basis determination is insufficient as a

predicate for regulation, and, instead, the EPA was required to determine that methane emissions from the oil and gas source category cause or contribute significantly to air pollution that is reasonably anticipated to endanger public health or welfare. Commenters took this same position in the 2016 NSPS OOOOa. For the reasons discussed immediately below, we disagree with commenters and we confirm the position in the 2016 rule. As we discuss further below, the 2016 rule also addressed commenters' objections by making a finding that the GHG emissions from the oil and gas source category contribute significantly to dangerous air pollution.

CAA section 111 is clear in authorizing the EPA to regulate air pollutants from a listed source category if it has a rational basis for doing so, and does not require, or authorize the EPA to require, a pollutant-specific significant contribution finding or endangerment finding as a predicate for such regulation. CAA section 111(b)(1)(A) requires the EPA to “publish . . . a list of categories of stationary sources” for regulation, and to “include a source category in such list if . . . it causes, or contributes significantly to, air pollution which may reasonably be anticipated to endanger public health or welfare.” CAA section 111(b)(1)(B) provides that within a specified time after listing the source category, the EPA shall promulgate “standards of performance for new sources within such category.” CAA section 111(a)(1) defines “standard of performance” (in the singular) as “a standard for emissions of air pollutants” that is determined in a particular manner. CAA section 307(d)(1)(C) provides that the EPA’s promulgation of standards of performance under CAA section 111 are subject to the requirements of CAA section 307(d). Those requirements include the judicial review provisions of CAA section 307(d)(9)(A), which provide that a court may reverse standards of performance “found to be arbitrary, capricious, an abuse of discretion, or otherwise not in accordance with law.”

By their terms, these provisions require the EPA to make an endangerment finding, including a significant contribution finding, for a source category as a predicate to promulgating standards of performance, and they establish detailed requirements that standards of performance must meet. However, by their terms, they do not require, or authorize the EPA to require, any significant contribution or endangerment findings for particular air pollutants as a predicate to

promulgating such standards. Instead, the EPA’s promulgation of such standards is subject to the CAA section 307(d)(9)(A) arbitrary and capricious standard for judicial review. *See American Electric Power Co. v. Connecticut*, 564 U.S. 410, 424, 427 (2011). In contrast, numerous other provisions explicitly require a pollutant-specific contribution or endangerment finding. *See, e.g.,* CAA section 183(f)(1)(A), 202(a)(1), 211(c)(1)(A), 213(a)(1)–(3), 231(a)(2). The inclusion of clear requirements for pollutant-specific findings in other CAA provisions confirms that the absence of such a requirement in CAA section 111 indicates Congress’ intention not to include such a requirement there. *See United States v. Gonzales*, 520 U.S. 1, 5 (1997) (“Where Congress includes particular language in one section of a statute but omits it in another section of the same Act, it is generally presumed that Congress acts intentionally and purposely in the disparate inclusion or exclusion.”) (internal quotations omitted).

Importantly, the arbitrary and capricious standard is tantamount to a standard of reasonableness or rationality. *See Motor Vehicle Mfrs. Ass’n of U.S., Inc. v. State Farm Mut. Auto. Ins. Co.*, 463 U.S. 29, 42–43 (1983) (*Motor Vehicle Mfrs. Ass’n*) (“[t]he scope of review under the ‘arbitrary and capricious’ standard” means that a court “may not set aside an agency rule that is [, among other things,] rational”). In the 2016 NSPS OOOOa, the EPA termed this standard the rational basis test, and applied it to the promulgation of GHG standards of performance for the oil and gas source category. This standard of review is well established, and courts routinely review rules under it, as noted in the House Report at 11.

On the other hand, requiring a pollutant-specific significant contribution finding as a predicate for promulgating NSPS would disrupt the scheme Congress set out because it would render the significant contribution and endangerment findings for the source category superfluous. This is because a finding that any particular air pollutant emitted from a source category contributes significantly to dangerous air pollution necessarily means that the source category itself contributes significantly to dangerous air pollution. *See TRW Inc. v. Andrews*, 534 U.S. 19, 31 (2001) (“It is a cardinal principle of statutory construction that a statute ought, upon the whole, to be so construed that, if it can be prevented, no clause, sentence, or word shall be superfluous. . . .”).

¹³⁸ See preamble section III.A. for further discussion on the Crude Oil and Natural Gas Emissions and Climate Change, including discussion of the GHGs, VOCs and SO₂ Emissions on Public Health and Welfare.

The EPA's more than half-century long regulatory history of CAA section 111 is consistent with the rational basis test and provides no precedent for requiring or authorizing the EPA to require a pollutant-specific significant contribution finding. The EPA first listed source categories and promulgated standards of performance for them in 1971, 36 FR 5931 (Mar. 31, 1971) (listing initial source categories); 36 FR 24876 (Dec. 23, 1971) (promulgating initial standards of performance), and since then, has listed dozens more source categories and promulgated hundreds of standards. 40 CFR part 60. The EPA has always listed source categories by determining that they contribute significantly to dangerous air pollution, and then has proceeded to promulgate NSPS for particular air pollutants from the source categories, without making comparable significant contribution or endangerment findings for those air pollutants.¹³⁹ The EPA has followed this approach when it has promulgated standards of performance for particular air pollutants at approximately the same time that it listed the source category, *see, e.g.*, 36 FR 5931 (Mar. 31, 1971) (listing five source categories); 36 FR 24876 (Dec. 23, 1971) (promulgating standards of performance for same five source categories), and when it has promulgated standards of performance for particular air pollutants for the first time many years after it listed the source category, and which it did not address when it listed the source category. *See* 38 FR 15380 (June 11, 1973) (listing the petroleum refineries source category), 39 FR 9310 (Mar. 8, 1974) (promulgating standards of performance for PM, CO, SO₂, and opacity from the source category), 73 FR 35838 (June 24, 2008) (promulgating standards of performance for NO_x and VOC from the source category).

In other rulemakings, the EPA declined to promulgate NSPS for certain air pollutants, on the basis of what amounted to a rational basis test, although the EPA did not use that specific terminology. *See* 42 FR 22056, 22507 (May 3, 1977) (declining to promulgate NSPS for NO_x, CO, and SO₂ from lime manufacturing plants due to limited amounts of emissions of pollutants or limited reductions that controls would achieve); *National Lime Assoc. v. EPA*, 627 F.2d 416, 426 & n.27 (D.C. Cir. 1980). On the other hand, in

rulemakings since 2009, the EPA has rejected comments that it was required to make a pollutant-specific significant contribution finding. *See* 74 FR 51950, 51957 (Oct. 8, 2009) (NSPS for coal preparation and processing plant source category); 80 FR 64510, 64530 (Oct. 23, 2015) (NSPS for GHG from electric utility generation source category); 2016 NSPS OOOOa, 81 FR 35843.

It is clear that interpreting CAA section 111 to require, or authorize the EPA to require, a pollutant-specific significant contribution finding as a predicate for regulation is novel and departs from the EPA's lengthy history of promulgating standards of performance.¹⁴⁰ This "consistent and longstanding interpretation of the agency charged with administering the statute" further supports interpreting CAA section 111 to base the promulgation of standards of performance on a rational basis standard, consistent with CAA section 307(d)(9)(A), and not to require a pollutant-specific significant contribution finding. *See Entergy Corp. v. Riverkeeper, Inc.*, 556 U.S. 208, 235 (2009). Indeed, interpreting CAA section 111 to require, or authorize the EPA to require, a pollutant-specific significant contribution finding as a predicate for regulation would undermine the EPA's implementation of CAA section 111 to date, including, in particular, virtually all of the standards of performance the EPA has promulgated to date.

In addition, even if commenters are correct that CAA section 111 requires a pollutant-specific finding, that finding should be simply a contribution, not a significant contribution. A contribution finding would be consistent with Congress's approach in other CAA provisions. *See, e.g.*, CAA section 183(f)(1)(A), 202(a)(1), 211(c)(1), 231(a)(2). A significant contribution finding is illogical because it would render the source category significant contribution finding under CAA section 111(b)(1)(A) superfluous, as noted

above. By analogy, CAA section 213(a)(4) explicitly requires the EPA make two findings, but differentiates them: (1) emissions from new nonroad engines or vehicles contribute significantly to an air pollution problem, and (2) emissions from classes or categories of new nonroad engines or vehicles cause or contribute to the air pollution problem. Accordingly, if CAA section 111 were interpreted to require, or at least authorize, the EPA to require a pollutant-specific finding as a predicate for regulation, that finding should be that the source category's emissions of the pollutant cause or contribute to dangerous air pollution.

c. Lack of Redundancy of Regulation of Methane

Commenters also argued that the GHG NSPS in the oil and gas source category are redundant to the VOC NSPS. Adverse commenters had made this objection during the 2016 NSPS OOOOa. We rejected it there and reject it here as well.

In the 2016 rule, the EPA structured the requirements of the VOC and GHG NSPS to mirror each other, and it is that structure that forms the basis for commenters' argument that the GHG NSPS should be considered to be redundant. Because the EPA had listed the oil and gas source category for regulation, it was required to promulgate NSPS for GHG emissions under CAA section 111(b)(1)(B) (as long as doing so was rational), and that requirement is not eliminated by the fact that the GHG NSPS could be structured to mirror the VOC NSPS. Moreover, the fact that the 2016 rule structured the requirements as it did does not mean they are redundant, only that the EPA sought to allow sources to comply with them as efficiently as possible. Had the EPA not been careful to structure the two sets of NSPS to mirror each other, no argument would have arisen that the GHG NSPS were redundant, but that would have been an inefficient regulatory scheme.

Most importantly, the GHG NSPS are not redundant because only they, and not the VOC NSPS, trigger the requirement that existing sources are subject to GHG emission guidelines under CAA section 111(d). The large contribution of methane emissions from the source category to dangerous air pollution driving the grave and growing threat of climate change means that, in the agency's judgment, it would be arbitrary and capricious under CAA section 307(d)(9)(A)—as well as highly irresponsible—for the EPA to decline to promulgate NSPS for methane emissions from the source category. *See*

¹³⁹ The only exceptions have been two rules in which the EPA made pollutant-specific significant contribution findings in the alternative. 80 FR 64510, 64531 (Oct. 23, 2015) (GHG NSPS for electric power plants); 2016 NSPS OOOOa, 81 FR 35843.

¹⁴⁰ The only actions in which CAA section 111 has been interpreted to require or authorize the EPA to require a pollutant-specific significant contribution finding as a predicate for regulation are the 2020 Policy Rule, which was disapproved by the CRA joint resolution, and a January 2021 rule that purported to establish a significance threshold for GHG emissions from source categories, but that was adopted without notice-and-comment, and was vacated by the D.C. Circuit in April 2021. *See* "Pollutant-Specific Significant Contribution Finding for Greenhouse Gas Emissions From New, Modified, and Reconstructed Stationary Sources: Electric Utility Generating Units, and Process for Determining Significance of Other New Source Performance Standards Source Categories—Final Rule," 86 FR 2542 (Jan. 13, 2021); *California v. EPA*, No. 21–1035 (D.C. Cir. April 5, 2021) Doc. #1893155 (order granting motion for voluntary vacatur and remand).

American Electric Power, 564 U.S. at 426–27.

d. Alternative Determination in the 2016 NSPS OOOOa for a Pollutant-Specific Endangerment Finding

The 2016 NSPS OOOOa re-listing of the source category, described above, included another alternative determination that provided an additional basis for the regulation of GHG emissions, which was that the EPA explicitly determined that GHG emissions from the Crude Oil and Natural Gas source category cause or contribute significantly to dangerous air pollution. 81 FR 35833–40. This determination—which, to be clear, the EPA is not required to do, but nevertheless did so in the alternative—further addressed commenters’ objections that the EPA was required to make such a pollutant-specific determination as a predicate for regulating methane emissions. The EPA has not reopened this determination.

As noted above, this type of determination entails two findings, a significant contribution finding and a finding of dangerous air pollution. In this case, those findings were for GHG emissions. We refer to the former as the pollutant-specific significant contribution finding. In the 2016 rule, the EPA based the pollutant-specific significant contribution finding on the same facts concerning the large amount of methane emissions from the oil and gas source category that it relied on in making the rational basis determination, as noted above. *Id.* 35842–43. It made the finding of dangerous air pollution based on the endangerment finding for GHG that the EPA made under CAA section 202(a) in 2009¹⁴¹ (the 2009 Endangerment Finding) and the 2010 denial of petitions to reconsider,¹⁴² updated with more recent information. See *Coalition for Responsible Regulation v. EPA*, 684 F.3d 102, 117–123 (D.C. Cir. 2012) (upholding the 2009 Endangerment Finding and 2010 denial of petitions to reconsider, and noting, among other things, the “substantial . . . body of scientific evidence marshaled by EPA in support”).

This pollutant-specific determination for GHG from the oil and gas source category addresses the commenters’ arguments that the EPA cannot regulate

GHG from the source category without making such a finding. See *American Lung Ass’n v. EPA*, 985 F.3d 914, 974–77 (D.C. Cir. 2021) (*American Lung Ass’n*) (the pollutant-specific significant-contribution finding that the EPA made in the alternative for GHG emissions from electric power plants provided a sufficient basis for regulation and addressed petitioners’ arguments that the NSPS for GHG emissions from those sources was invalid due to lack of such a finding), *rev’d in part sub nom West Virginia v. EPA*, 142 S.Ct. 2587 (2022) (*West Virginia*).¹⁴³

Commenters also argued that an endangerment finding specifically for methane emissions—that is, a determination that methane emissions from the oil and gas source category cause or contribute significantly to atmospheric levels of methane, and that those levels may reasonably be anticipated to endanger public health or welfare—is necessary as a predicate for regulation of methane emissions from the source category. The EPA responded to the same comment in the 2016 NSPS OOOOa. 81 FR 35841–42, 35877. The EPA is not reopening this issue, but for the purpose of providing information to the public, will explain why, assuming that a pollutant-specific determination is necessary as a predicate for CAA section 111 regulation, it is appropriate for the EPA to make the significant contribution finding on the basis of GHG emissions and for the EPA to rely on the finding of dangerous air pollution that it made for GHG, and it is not necessary for the EPA to make comparable determinations for methane emissions.

The EPA’s approach in the 2016 NSPS OOOOa to make the findings for GHG is fully consistent with other rulemakings in which this issue arose. The first was the 2009 Endangerment Finding. 74 FR 66496. CAA section 202(a)(1) requires the EPA to establish “standards applicable to the emission of any air pollutant from any class or classes of new motor vehicles or new motor vehicle engines” that “in his judgment cause, or contribute to, air pollution which may reasonably be anticipated to endanger public health or welfare.” The EPA explained that this provision sets forth a two-part test for regulatory action: first, whether the relevant air pollutant may reasonably be anticipated to endanger public health or welfare, and second, whether emissions of any air pollutant from the class or classes of

the sources in question (there, new motor vehicles) cause or contribute to this air pollution. 74 FR 66505, 66516, 66536. The EPA explained that “the air pollution can be thought of as the total, cumulative stock in the atmosphere, while the air pollutant can be thought of as the flow that changes the size of the total stock.” 74 FR 66536 (emphasis omitted). The EPA went on to explain that the “air pollution” that it was determining endangered public health and welfare is the elevated atmospheric concentrations of “the combined mix of six key directly-emitted, long-lived and well-mixed greenhouse gases”—carbon dioxide, methane, nitrous oxide, hydrofluorocarbons, perfluorocarbons, and sulfur hexafluorides. *Id.* 66516–23. The EPA supported this conclusion by explaining, among other things, that these six gases have the common attributes regarding their climate effects. *Id.* 66517. For the same reasons, in the 2009 Endangerment Finding, the EPA also defined the air pollutant as GHG—a single air pollutant made up of the same six gases in an aggregate group for purposes of determining whether the air pollutant causes or contributes to the endangering air pollution. *Id.* 66537. The EPA explained that “they are all greenhouse gases that are directly emitted . . .; they are sufficiently long-lived in the atmosphere such that, once emitted, concentrations of each gas become well mixed throughout the entire global atmosphere; and they exert a climate warming effect by trapping outgoing, infrared heat that would otherwise escape to space. Moreover, the radiative forcing effect of these six greenhouse gases is well understood.” *Id.* The EPA further explained that this definition of the GHG air pollutant was reasonable, even if emissions from the source category did not include all six gases. *Id.* In fact, in the 2009 Endangerment Finding, the EPA noted that the emissions from the relevant class or classes of new motor vehicles or new motor vehicle engines included only four of the gases. *Id.* 66538, 66541. As noted in section III.A.1 above, the oil and gas source category emits methane and CO₂, although the limits established in this action focus on regulating GHG through requirements that are expressed in the form of limits on methane, as a constituent of the GHG air pollutant.

In subsequent actions that entailed or referenced GHG endangerment findings, the EPA has taken the same position that the air pollution consists of the elevated atmospheric concentrations of these six greenhouse gases and the air pollutant consists of the mix of the same six gases. 81 FR 54422 (2016 GHG

¹⁴¹ “Endangerment and Cause or Contribute Findings for Greenhouse Gases Under Section 202(a) of the Clean Air Act,” 74 FR 66496 (Dec. 15, 2009).

¹⁴² See “EPA’s Denial of the Petitions To Reconsider the Endangerment and Cause or Contribute Findings for Greenhouse Gases Under Section 202(a) of the Clean Air Act,” 75 FR 49556 (August 13, 2010).

¹⁴³ It should be noted that the part of the D.C. Circuit’s opinion in *American Lung Ass’n* concerning the pollutant-specific significant contribution finding was not affected by the Supreme Court’s decision in *West Virginia*.

endangerment and cause or contribute finding for certain aircraft under CAA section 231(a)(2)(A)). The EPA took this same position in the 2016 NSPS OOOOa, as mentioned at the beginning of this section. 81 FR 35833, 35877. For the same reasons that the EPA has consistently articulated in the 2009 Endangerment Finding and afterwards, it is appropriate to base that determination on the contribution of GHG emitted from the source category to atmospheric GHG levels. This is because, as noted above, the 2016 rule identifies the air pollutant as GHG, even though it expresses the requirements in the form of limits on methane. 40 CFR 60.5360a. Any significant contribution finding must address the pollutant being regulated, in this case, GHG. In addition, for the finding of dangerous air pollution, the air pollution of concern is the elevated concentration of the six well-mixed greenhouse gases, and not only concentrations of methane.

e. Standards or Criteria for Determining Significance

Commenters argued that when the EPA makes a significant contribution determination for the pollutant and the source category as a predicate for regulation, the EPA must first establish a standard or criteria for when a contribution is significant.¹⁴⁴ They stated that such a standard or criteria is necessary to allow the EPA to distinguish between a contribution and a significant contribution, and that without it, the significant contribution finding is arbitrary. The EPA disagrees with this comment. Rather, it is fully appropriate for the EPA to exercise its discretion to employ a facts-and-circumstances approach, particularly in light of the wide range of source categories and the air pollutants they emit that the EPA must regulate under CAA section 111.

With respect to the significant contribution finding for a source category, CAA section 111(b)(1)(A) by its terms does not require that such a finding be based on established criteria or a standard or threshold. In fact, during the 50 years that it has listed dozens of source categories,¹⁴⁵ the EPA has never identified a standard or criteria for determining significance, and instead, has always relied on the particular facts and circumstances. This approach is appropriate because Congress intended that CAA section 111

apply to a wide range of source categories and pollutants, from wood heaters to emergency backup engines to petroleum refineries. In that context, it is reasonable to interpret CAA section 111 to allow the EPA the discretion to determine how best to assess significant contribution and endangerment based on the individual circumstances of each pollutant and each source category. For example, among the six well-mixed gases that comprise GHG, CO₂ is emitted in the greatest quantities while methane emissions have a greater impact than CO₂ emissions on a per-ton basis. In addition, source categories that emit the same air pollutant may differ from each other in several ways that may be relevant for purposes of a significance finding, including whether new sources are expected to be constructed.

With respect to any significant contribution finding for an air pollutant—and as noted above, CAA section 111 does not require one as a predicate for regulation—established criteria or standards are also not required. The D.C. Circuit adopted this position in *American Lung Ass'n*, 985 F.3d at 976–77, when it upheld the EPA's pollutant-specific significant-contribution finding for GHG emissions from electric power plants even though the EPA did not “articulate a specific threshold measurement for significance.” The court relied on the same reasoning that it used when, in upholding the 2009 Endangerment Finding, it rejected an argument that the EPA must establish criteria in order to determine that an air pollutant endangers public health and welfare. *Coal. for Responsible Regulation, Inc. v. EPA*, 684 F.3d 102 (D.C. Cir. 2012). The court stated that “EPA need not establish a minimum threshold of risk or harm before determining whether an air pollutant endangers” because “the inquiry necessarily entails a case-by-case, sliding-scale approach.” *Id.* at 122–23. Although there, the court was discussing whether an air pollutant endangers public health or welfare, the court later, in *American Lung Ass'n*, made clear that the same principle applies to whether an air pollutant contributes significantly to dangerous air pollution. On this point, as well, the EPA is in full agreement with the statements in the House Report stating that the EPA is not required to base a significance finding on an established standard or criteria. House Report at 9–10.

Commenters who interpret CAA section 111 to require a pollutant-specific significant contribution finding rely on the requirement in CAA section 111(b)(1)(A) for a source-category

significant endangerment finding. By that logic, the facts-and-circumstances method by which the EPA has always determined the source category significant-contribution finding should also apply to any pollutant-specific significant contribution finding. See *Alaska Dep't of Env'tl. Conservation*, 540 U.S. 461, 487 (2004) (explaining, in a case under the CAA, “[w]e normally accord particular deference to an agency interpretation of longstanding duration” (internal quotation marks omitted) (citing *Barnhart v. Walton*, 535 U.S. 212, 220 (2002)). In fact, in each of the first two rules in which the EPA made a pollutant-specific significant contribution finding as an alternative basis for regulating GHG from the relevant source category, the EPA relied on a facts-and-circumstances test for determining significance. 80 FR 64531 (NSPS for GHG from electric power plants); 2016 NSPS OOOOa, 81 FR 35843.¹⁴⁶ The EPA's long track record for basing CAA section 111 significance findings on an examination of facts and circumstances, and not relying on established criteria or other standards or thresholds, coupled with the importance of allowing the EPA the flexibility to take into account the particular circumstances of the pollutant and the source category, makes clear that a lack of such criteria or standards does not render the significance determinations arbitrary and capricious. The courts have long reviewed agency actions under the arbitrary-and-capricious standard without requiring quantitative or numerical standards. See *Motor Vehicle Mfrs. Ass'n*, 463 U.S. 42–43 (stating that the court “may not set aside an agency rule that is rational, based on consideration of the relevant factors and within the scope of the authority delegated to the agency by the statute”).

Other CAA provisions require the EPA to make a pollutant-specific determination, and the EPA's actions under these provisions are informative here as well. The EPA has implemented some of these provisions through a facts and circumstances test, see 59 FR 31308 (June 17, 1994) (under CAA section 213, in determining whether emissions from nonroad engines and vehicles contribute significantly to dangerous air pollution, the EPA made a qualitative assessment, and rejected assertions by commenters

¹⁴⁴ Comments of Permian Basin Petroleum Ass'n, Document ID No. EPA-HQ-OAR-2021-0317-0793 at 3–4 (citing 85 FR 57018, 57038 (September 14, 2020)).

¹⁴⁵ List of Categories of Stationary Sources, 36 FR 5931 (March 31, 1971); see 40 CFR part 60.

¹⁴⁶ As noted above, a January 2021 rule, promulgated without notice and comment and vacated by the D.C. Circuit, took the position that standards or criteria for a pollutant-specific significant contribution finding are necessary. 86 FR 2542; *California v. EPA*, No. 21–1035 (D.C. Cir. April 5, 2021) Doc. #1893155 (order granting motion for voluntary vacatur and remand).

that it was required to determine a specific numerical standard for significance); and has implemented some of these provisions through both a facts and circumstances test and criteria or standards. *See* 84 FR 50268 (Sept. 24, 2019) (proposal for 2020 Policy Rule; discusses EPA action under CAA section 189(e), which requires the EPA to regulate sources of precursors to PM₁₀ except where EPA determines such sources do not contribute significantly to PM₁₀ levels that exceed the NAAQS; EPA has determined significance through a combination of a facts-and-circumstances test and criteria); *compare id.* at 50267–68 (discussing EPA’s implementation of CAA section 110(a)(2)(D)(i), the Good Neighbor Provision, which requires states to prohibit emissions “in amounts which will contribute significantly to nonattainment” of the NAAQS in any other state; in rules concerning ozone and PM_{2.5}, the EPA has identified a numerical criterion for determining significant contribution) with 84 FR 54498, 54499 (October 10, 2019) (in rules under the Good Neighbor Provision concerning the SO₂ NAAQS, EPA has applied a weight of evidence (that is, evaluating all available facts and circumstances) test for determining whether there is significant contribution). The fact that the EPA has sometimes relied on a facts-and-circumstances test for determining significance in these CAA provisions supports its view that such a test is reasonable under CAA section 111.

If the EPA were required to develop a standard or criteria to determine significance, any reasonable standard or criteria would necessarily focus on the amount of emissions from the source category and the harmfulness of the pollutant emitted. In the case of the oil and gas source category, the “massive quantities of methane emissions” contributed by the sector to the levels of well-mixed GHG in the atmosphere, as described in the November 2021 Proposal, 86 FR 63148, coupled with the potency of methane (with a global warming potential (GWP) of almost 30 or more than 80, depending on the time period of the impacts, *id.* 63130), demonstrate that the source category’s GHG emissions would be significant under any reasonable criteria-based approach. *See* 86 FR 63131.

In particular, the fact that the oil and gas source category has the largest amount of methane emissions in the United States, in the context of a problem such as climate change that is caused by the collective contribution of many different sources, confirms that those emissions would meet any

reasonable standard or criteria for significance.¹⁴⁷ *See American Lung Ass’n*, 985 F.3d at 977 (“The global nature of the air pollution problem means that ‘[a] country or a source may be a large contributor, in comparison to other countries or sources, even though its percentage contribution may appear relatively small’ in the context of total emissions worldwide.” (quoting 2009 Endangerment Findings)). In fact, as noted above and discussed at further length in the December 2022 Supplemental Proposal, 87 FR 74719–20, the oil and gas source category’s position as the largest methane-emitting source category in the U.S. would itself qualify as a criterion that supports treating it as a significant contributor of methane, if such a criterion were necessary.

2. Commenters’ Arguments Concerning the CRA Joint Resolution and its Legislative History

Commenters dismiss the significance of the CRA joint resolution that disapproved the 2020 Policy Rule by arguing that although the joint resolution had the effect of reinstating the 2016 NSPS OOOOa, it did not change the underlying requirements of CAA section 111, so that the flaws the commenters perceived in the 2016 rule’s positions remained. The commenters further argue that the legislative history of the joint resolution that supported the 2016 rule’s positions is irrelevant. We disagree with these commenters. Under the CRA, the enactment of the joint resolution not only disapproved the 2020 Policy Rule and had the effect of reinstating the 2016 rule, it also prohibited the EPA from promulgating

¹⁴⁷ The EPA acknowledges that the collective nature of the climate change problem means that other source categories of methane emissions that are not necessarily as large as the oil and gas source category may also require regulation, *cf. EPA v. EME Homer City*, 572 U.S. 489, 514 (2014) (affirming framework to address “the collective and interwoven contributions of multiple upwind States” to ozone nonattainment), as indicated by the fact that the EPA has long regulated landfill gas, which consists of methane in 50 percent part. “Emission Guidelines and Compliance Times for Municipal Solid Waste Landfills; Final Rule,” 81 FR 59276, 59281 (August 29, 2016). But this does not necessarily mean that it would be appropriate to regulate *all* other types of sources, even ones with few emissions. In the past, the EPA has declined to regulate air pollutants emitted from source categories in quantities too small to be of concern and when regulation would have produced little environmental benefit for other reasons. *See Nat’l Lime Ass’n v. EPA*, 627 F.2d 416, 426 & n.27 (D.C. Cir. 1980) (small amounts of emissions of nitrogen oxides and carbon monoxide from lime kilns was a key factor in EPA decision not to promulgate new source performance standards for those pollutants; citing Standards of Performance for New Stationary Sources Lime Manufacturing Plants—Proposed Rule, 42 FR 22506, 22507 (May 3, 1977)).

another rule that is “substantially the same” as the 2020 Policy Rule. CRA section 801(b)(2). The joint resolution, confirmed by its legislative history, made clear what rules would and would not be prohibited. The commenters’ arguments, if accepted, would lead to the adoption of a rule that would be considered substantially the same as the 2020 rule, and for that reason, their arguments must be rejected. In this section, we provide background information concerning the CRA and the role of legislative history, we summarize the discussion in the joint resolution’s legislative history, and then we explain why commenters’ arguments must be rejected.

a. The CRA Joint Resolution of Disapproval

Congress enacted the CRA in 1996 to facilitate Congressional oversight of agency action by streamlining the process for adopting legislation to disapprove agency rules.¹⁴⁸ The CRA provides the specific wording for a joint resolution of disapproval for an agency action, which is a sentence that states (including the standard prefatory phrase for a joint resolution): “Resolved by the Senate and House of Representatives of the United States of America in Congress assembled, That Congress disapproves the rule submitted by the ___ relating to ___, and such rule shall have no force or effect.” 5 U.S.C. 802(a). The blank spaces are for the name of the agency and the rule. The CRA further provides that after Congress adopts a joint resolution of disapproval of an agency rule, the agency is precluded from promulgating a new rule that is “substantially the same” as the disapproved rule, absent a new act of Congress authorizing such a rule. CRA section 801(b)(2).

Notwithstanding this constraint, the affected agency may still have the discretion to, and in fact may still be required to, promulgate further rulemaking in accordance with the underlying statute that authorized the disapproved rule. The legislative history of the joint resolution may clarify the parts of the disapproved rule that Congress objected to, and thereby clarify what subsequent rules would or would not be substantially the same as the disapproved rule. The potential importance of legislative history that accompanies a joint resolution and that explains Congress’s objections to the rule, is highlighted by the fact that the legislative language of the joint resolution is, by the terms of the CRA,

¹⁴⁸ Congressional Research Service, “The Congressional Review Act (CRA): Frequently Asked Questions (Jan. 14, 2020) at 1–2.

simply a one-sentence disapproval of the agency action, as noted above.

b. CRA Joint Resolution of Disapproval of the 2020 Policy Rule

The joint resolution of disapproval of the 2020 Policy Rule provided, consistent with the form mandated under the CRA, “Resolved by the Senate and House of Representatives of the United States of America in Congress assembled, That Congress disapproves the rule submitted by the Administrator of the Environmental Protection Agency relating to “Oil and Natural Gas Sector: Emission Standards for New, Reconstructed, and Modified Sources Review” (85 FR 57018 (September 14, 2020)), and such rule shall have no force or effect.”¹⁴⁹ In adopting it, Congress explained its understanding of CAA section 111 and, based on that, its reasons why the 2020 Policy Rule was inconsistent with CAA section 111 and must be disapproved. Specifically, as discussed in the November 2021 Proposal and summarized above, the Senate floor debate over the joint resolution and the House Report made clear Congress’s views concerning the relevant provisions of CAA section 111 and the statutory interpretations contained in the 2016 NSPS OOOOa and the 2020 Policy Rule, and its intention that the EPA take further rulemaking action consistent with those views. Thus, the legislative history made clear that Congress (i) intended the EPA to treat the transmission and storage segment as part of the Crude Oil and Natural Gas Production source category and to promulgate NSPS and emission guidelines for GHG from the source category, (ii) viewed the 2016 rule’s statutory interpretations of CAA section 111 to be correct and to serve as the basis for these regulatory actions, and (iii) viewed the contrary statutory interpretations contained in the 2020 rule to be incorrect. The statutory interpretations that Congress viewed to be correct include that the EPA is not authorized to promulgate a pollutant-specific significant contribution finding as a predicate for regulation, and that a facts and circumstances test for determining significant contribution for the source category listing is appropriate.

c. Commenters’ Arguments and the EPA’s Responses

Commenters assert that while the CRA joint resolution disapproved the 2020 Policy Rule, that action did not extend to the legal rationale and policy

positions in the 2020 rule, and did not endorse the legal rationale and policy positions in the 2016 rule. They also assert that only the text of the joint resolution—again, a single sentence, quoted above, stating that Congress disapproves the 2020 rule and it shall have no force or effect—is relevant, and that the legislative history is not relevant. The commenters then assert that the joint resolution did not change the requirements of CAA section 111. From there, they assert that CAA section 111 requires the interpretations and determinations that the 2020 Policy Rule made, including that in order for the EPA to promulgate NSPS for sources in the transmission and storage segment, the EPA must first list that segment as a separate source category, including making significant contribution and endangerment findings for it; and in order for the EPA to promulgate NSPS for GHG emissions from oil and gas sources, the EPA must first make a pollutant-specific significant contribution finding, including specifying a standard or criterion for significance.

The EPA rejects the commenters’ arguments. In essence, commenters seek to minimize the importance of the joint resolution in order to argue that the EPA must rescind most of the 2016 NSPS OOOOa on grounds that it is inconsistent with CAA section 111’s requirements, as the commenters see them. However, such a rescission rule would be substantially the same as the 2020 Policy Rule, and is therefore precluded by the joint resolution.

The central features of the disapproved 2020 Policy Rule were its position that the transmission and storage segment is separate from the production and processing segments; its position that a GHG-specific significant contribution finding, supported by standards or criteria for determining significance, was a necessary predicate for regulating GHG emissions; and the statutory interpretations that underlay those positions. In addition, the legislative history of the CRA resolution made clear that Congress disapproved the 2020 Policy Rule because it rejected those positions and the underlying legal interpretations. Thus, a rule that adopted the same positions and interpretations as the 2020 Policy Rule would be precluded by the joint resolution as substantially the same as the 2020 Policy Rule.

Looked at another way, the commenters’ in essence argue that the EPA should withdraw the November 2021 Supplemental Proposal and instead propose and promulgate a rule stating

that the EPA is not authorized to further regulate oil and gas sources, including promulgating emission guidelines, unless it lists the transmission and storage segment as a separate source category and makes a pollutant-specific significant contribution finding for GHGs,¹⁵⁰ based on standards or criteria for determining significance. However, such a rule would also be precluded by the joint resolution as substantially the same as the key aspects of the 2020 Policy Rule because it would be based on the same statutory interpretations as that rule. Indeed, it is difficult to see what effect the disapproval would have if not to preclude the EPA from reinstating the positions and underlying legal interpretations included in the 2020 Policy Rule.

These commenters also err in asserting that the legislative history is irrelevant. Agencies and courts regularly look to legislative history to inform their actions and decisions. This makes particular sense in the case of a CRA joint resolution given the very limited language Congress may use in the joint resolution itself. Commenters also argue that the EPA’s position that the joint resolution of disapproval applies to the legal and policy positions in the 2020 Policy Rule would call into question the interpretations of CAA section 111 that the rule included that are noncontroversial and necessary to proper implementation of the provision. There is no reason to think that Congress would have objected to those interpretations, but in any event, this argument by commenters makes clear that the joint resolution’s legislative history is useful because it clarifies which interpretations and positions in the rule that Congress did object to.

After reviewing the text of the disapproval and, separately, the disapproval resolution’s legislative history, the EPA is proceeding with further rulemaking under CAA section 111 for sources in the Crude Oil and Natural Gas source category. With the 2016 Rule reinstated by the operation of the CRA resolution, the EPA is revising and adding certain NSPS and is promulgating emission guidelines for existing sources. These actions apply to sources in the transmission and storage segment, and apply to methane emissions. This rule is fully consistent with the CRA joint resolution.

¹⁵⁰ As noted above, commenters’ argument that the EPA must make a pollutant-specific significant contribution finding for GHG emissions from the source category has been addressed because the 2016 NSPS OOOOa made such a finding in the alternative.

¹⁴⁹ S.J. Res. 14—117th Congress, Public Law 117–23.

VI. Other Actions and Related Efforts

This section of this preamble describes related state actions and other Federal actions regulating oil and natural gas emissions sources; industry and voluntary efforts to reduce methane emissions from this sector; and other EPA programs to reduce methane emissions, including the Methane Emissions Reduction Program that was signed into law as part of the Inflation Reduction of 2022. The final NSPS OOOOb and EG OOOOc include specific measures that build on the experience and knowledge the Agency and industry have gained through voluntary programs and previous regulatory efforts, as well as the leadership of the states in developing their own regulatory programs. The final NSPS OOOOb and EG OOOOc consists of reasonable, proven, cost-effective technologies and practices that reflect the evolutionary nature of the oil and natural gas industry and these proactive regulatory and voluntary efforts.

At the same time, the final NSPS OOOOb and EG OOOOc reflect the EPA's unique authority and responsibility under the CAA to ensure that new and existing sources throughout the nation are subject to appropriate standards of performance through NSPS and approved state plans. By requiring all owners and operators of the sources regulated in this final rulemaking to limit methane emissions, the EPA intends to achieve methane emission reductions on a more consistent and comprehensive basis than has been achieved through current programs and efforts. Direct Federal regulation of methane and VOCs from new sources, combined with approved state plans that are consistent with the EPA's EG for methane from existing sources, will bring national consistency to the regulatory landscape, help promote technological innovation, and reduce both climate- and other health-harming pollution from a large number of sources that are either currently unregulated or where additional cost-effective reductions are available.

A. Related State Actions and Other Federal Actions Regulating Oil and Natural Gas Sources

The EPA recognizes that several states currently regulate emissions from the oil and natural gas industry.¹⁵¹ The EPA also recognizes that some of these state programs have been expanded and strengthened since the EPA began

implementing its 2012 NSPS and subsequent 2016 NSPS. These state-level efforts have been important in spurring the deployment of emission control technologies and practices, and developing a broad base of experience that has informed the final rule. At the same time, the EPA recognizes that state-level regulatory efforts cannot, alone, address the increasingly dangerous impacts of methane emissions on public health and welfare. State agencies regulate in accordance with their own authorities and within their own respective jurisdictions; as a result, there is considerable variation in the scope and stringency of such programs. Collectively, these programs do not fully address the range of sources and emission reduction measures contained in this rulemaking. The EPA is committed to working within its authority to provide opportunities to align its programs with these existing state programs in order to reduce regulatory redundancy where appropriate.

In addition to states, certain Federal agencies also regulate aspects of the oil and natural gas industry pursuant to their own authorities. The EPA has maintained an ongoing dialogue with its Federal partners during the development of this final rulemaking in order to avoid potential regulatory conflicts and unnecessary regulatory obligations on the part of owners and operators as each agency responds to its particular statutory charge.

The below description summarizes other Federal regulations and programs related to air emissions from the oil and natural gas industry. The U.S. Department of the Interior (DOI) regulates the extraction of oil and gas from Federal and Indian lands. DOI bureaus that are responsible for administering natural resources conservation and safety related to onshore and offshore energy development include the Bureau of Land Management (BLM) (Federal onshore fossil fuel related activities), the Bureau of Safety and Environmental Enforcement (Federal offshore safety and environmental protection of oil and gas development), and the Bureau of Ocean Energy Management (BOEM) (Federal offshore oil and gas related activities). The BLM manages the Federal Government's onshore subsurface mineral estate—about 700 million acres (30 percent of the U.S.)—for the benefit of the American public. The BLM maintains the Federal onshore oil and gas leasing program pursuant to the Mineral Leasing Act, the Mineral Leasing Act for Acquired Lands, the Federal Land Management and Policy

Act, and the Federal Oil and Gas Royalty Management Act. The BLM's oil and gas operating regulations are found in 43 CFR part 3160. An oil and gas operator's general environmental and safety obligations for onshore activities are found at 43 CFR 3162.5. Pursuant to a delegation of Secretarial authority, the BLM also oversees oil and gas operations on many Indian/Tribal leases.

The BLM has the express authority and responsibility to regulate both for the prevention of waste and the protection of the environment for operations on Federal and Indian lands. This responsibility includes promulgating regulations to reduce the waste of natural gas from oil and gas leases administered by the BLM. This gas is lost during oil and gas exploration and production activities through venting, flaring, and leaks. More detailed information can be found at the BLM's website: <https://www.blm.gov/programs/energy-and-minerals/oil-and-gas/operations-and-production/methane-and-waste-prevention-rule>.

BOEM manages the development of U.S. Outer Continental Shelf (offshore) energy and mineral resources. BOEM has air quality jurisdiction in the Gulf of Mexico¹⁵² and the North Slope Borough of Alaska.¹⁵³ BOEM also has air jurisdiction in Federal waters on the Outer Continental Shelf 3–9 miles offshore (depending on the state) and beyond. The Outer Continental Shelf Lands Act (OCSLA), section 5(a)(8) states, "The Secretary of the Interior is authorized to prescribe regulations 'for compliance with the national ambient air quality standards pursuant to the CAA . . . to the extent that activities authorized under [the Outer Continental Shelf Lands Act] significantly affect the air quality of any state.'" The EPA and states have the air jurisdiction onshore and in state waters, and the EPA has air jurisdiction offshore in certain areas. More detailed information can be found at BOEM's website: <https://www.boem.gov/>.

The U.S. Department of Transportation (DOT) manages the U.S. transportation system. Within DOT, the Pipeline and Hazardous Materials Safety Administration (PHMSA) is responsible for regulating and ensuring the safe and secure transport of energy and other hazardous materials to industry and consumers by all modes of transportation, including pipelines.

¹⁵² The CAA gave BOEM air jurisdiction west of 87.5 degrees longitude in the Gulf of Mexico region.

¹⁵³ The Consolidated Appropriations Act of 2012 gave BOEM air jurisdiction in the North Slope Borough of Alaska.

¹⁵¹ The EPA summarized examples of state programs in the November 2021 Proposal and November 2021 TSD. See 86 FR 63137 and Document ID No. EPA-HQ-OAR-2021-0317-0166.

While PHMSA regulatory requirements for gas pipeline facilities have focused on human safety, which has attendant environmental co-benefits, the “Protecting our Infrastructure of Pipelines and Enhancing Safety Act of 2020” (Pub. L. 116–260, Division R; “PIPES Act of 2020”), which was signed into law on December 27, 2020, revised PHMSA organic statutes to emphasize the centrality of environmental safety and protection of the environment in PHMSA decision making. For example, the PHMSA’s Office of Pipeline Safety ensures safety in the design, construction, operation, maintenance, and incident response of the U.S.’ approximately 3.3 million miles of natural gas and hazardous liquid transportation pipelines. When pipelines are maintained, the likelihood of environmental releases like leaks are reduced.¹⁵⁴ In addition, the PIPES Act of 2020 contains several provisions that specifically address the minimization of releases of natural gas from pipeline facilities, such as a mandate that the Secretary of Transportation promulgate regulations related to gas pipeline LDAR programs. More detailed information can be found at PHMSA’s website: <https://www.phmsa.dot.gov/>.

The U.S. Department of Energy (DOE) develops oil and natural gas policies and funds research on advanced fuels and monitoring and measurement technologies. Specifically, the Advanced Research Projects Agency-Energy (ARPA-E) program advances high-potential, high-impact energy technologies that are too early for private-sector investment. ARPA-E awardees are unique because they are developing entirely new technologies. More detailed information can be found at ARPA-E’s website: <https://arpa-e.energy.gov/>. Also, the U.S. Energy Information Administration (EIA) compiles data on energy consumption, prices, including natural gas, and coal. More detailed information can be found at the EIA’s website: <https://www.eia.gov/>.

The U.S. Federal Energy Regulatory Commission (FERC) is an independent agency that regulates the interstate transmission of electricity, natural gas,¹⁵⁵ and oil.¹⁵⁶ FERC also reviews proposals to build liquefied natural gas terminals and interstate natural gas pipelines, and licenses hydropower

projects. FERC’s responsibilities for the crude oil industry include the following: regulation of rates and practices of oil pipeline companies engaged in interstate transportation; establishment of equal service conditions to provide shippers with equal access to pipeline transportation; and establishment of reasonable rates for transporting petroleum and petroleum products by pipeline. FERC’s responsibilities for the natural gas industry include the following: regulation of pipeline, storage, and liquefied natural gas facility construction; regulation of natural gas transportation in interstate commerce; issuance of certificates of public convenience and necessity to prospective companies providing energy services or constructing and operating interstate pipelines and storage facilities; regulation of facility abandonment, establishment of rates for services; regulation of the transportation of natural gas as authorized by the Natural Gas Policy Act and OCSLA; and oversight of the construction and operation of pipeline facilities at U.S. points of entry for the import or export of natural gas. FERC has no jurisdiction over construction or maintenance of production wells, oil pipelines, refineries, or storage facilities. More detailed information can be found at FERC’s website: <https://www.ferc.gov/>.

B. Industry and Voluntary Actions To Address Climate Change

Separate from regulatory requirements, some owners or operators of facilities in the oil and natural gas industry choose to participate in voluntary initiatives to reduce methane emissions from their operations. Over 100 oil and natural gas companies have participated in the EPA Natural Gas STAR Program and Methane Challenge partnership over the past several decades. Owners or operators also participate in a growing number of voluntary programs unaffiliated with the EPA voluntary programs; the EPA is aware of at least 19 such initiatives.¹⁵⁷ Firms participate in voluntary environmental programs for a variety of reasons, including attracting customers, employees, and investors who value more environmentally-responsible goods and services; finding approaches

to improve efficiency and reduce costs; and preparing for or helping inform future regulations.^{158 159}

The EPA’s Natural Gas STAR Program started in 1993 with the objective of achieving methane emission reductions through implementation of cost-effective best practices and technologies. Through the program, partner companies documented their voluntary emission reduction activities and reported their accomplishments to the EPA annually. Over the course of the Natural Gas STAR Partnership from 1993 to 2022, the EPA collaborated with over 100 companies across the natural gas value chain. Through the partnership, the EPA tracked more than 150 different methane-reducing activities and technologies which it then shared among partners and through the program website. Between 1993 and 2020, partner companies reported cumulative methane emissions reductions of nearly 1.7 trillion cubic feet.

The EPA’s Methane Challenge Program was launched in 2016 to expand upon the Natural Gas STAR Program by providing partner companies the opportunity to make ambitious, quantifiable emissions reduction commitments, provide detailed, transparent reporting, and receive partner recognition. Annually, Methane Challenge Partners submit facility-level reports that characterize methane emission sources at their facilities and detail voluntary actions taken to reduce methane emissions. The EPA emphasizes the importance of transparency by publishing these facility-level data. Since its inception, the Methane Challenge Program has included nearly 70 companies and currently has 54 active partners, primarily from the transmission and distribution segments.

Other voluntary programs for the oil and natural gas industry are administered by numerous organizations, including trade associations and non-profits. These voluntary efforts have helped reduce methane emissions beyond what is required by current regulations, as well as to significantly expand the understanding of methane mitigation measures within the industry and among Federal and state regulators. Although the EPA recognizes and commends the value of these programs, such voluntary efforts are not legally

¹⁵⁴ See Final Report on Leak Detection Study to PHMSA, December 10, 2012. <https://www.phmsa.dot.gov/sites/phmsa.dot.gov/files/docs/technical-resources/pipeline/16691/leak-detection-study.pdf>.

¹⁵⁵ <https://www.ferc.gov/industries-data/natural-gas>.

¹⁵⁶ <https://www.ferc.gov/industries-data/oil>.

¹⁵⁷ Highwood Emissions Management (2021). “Voluntary Emissions Reduction Initiatives for Responsibly Sourced Oil and Gas.” Available for download at: <https://highwoodemissions.com/research/>.

¹⁵⁸ Borck, J.C. and C. Coglianese (2009). “Voluntary Environmental Programs: Assessing Their Effectiveness.” Annual Review of Environment and Resources 34(1): 305–324.

¹⁵⁹ Brouhle, K., C. Griffiths, and A. Wolverton. (2009). “Evaluating the role of EPA policy levers: An examination of a voluntary program and regulatory threat in the metal-finishing industry.” Journal of Environmental Economics and Management. 57(2): 166–181.

binding and do not alter the EPA's own statutory responsibility to regulate methane emissions from this sector under the CAA. Moreover, as the information and analysis reflected in this final rulemaking make clear, there is still considerable need and opportunity to further reduce methane emissions from the industry.

C. Methane Emissions Reduction Program

In August 2022, Congress passed, and President Biden signed, the Inflation Reduction Act of 2022 into law. Section 60113 of the Inflation Reduction Act of 2022 amended the CAA by adding section 136, "Methane Emissions and Waste Reduction Incentive Program for Petroleum and Natural Gas Systems" (also referred to as the "Methane Emissions Reduction Program").

Subsections (a) and (b) of CAA section 136 provide \$1.55 billion for the Methane Emissions Reduction Program, including for incentives for methane mitigation and monitoring. The EPA is partnering with the DOE and National Energy Technology Laboratory to provide financial assistance for monitoring and reducing methane emissions from the oil and gas sector, as well as technical assistance to help implement solutions for monitoring and reducing methane emissions. As designed by Congress, these incentives were intended to complement the regulatory programs and to help facilitate the transition to a more efficient petroleum and natural gas industry.

On August 1, 2023, the EPA proposed revisions to GHGRP subpart W consistent with the authority and directives set forth in CAA section 136(h), as well as the EPA's authority under CAA section 114 (88 FR 50282). In that rulemaking, the EPA proposed revisions to require reporting of additional emissions or emissions sources to address potential gaps in the total methane emissions reported by facilities to GHGRP subpart W. For example, these proposed revisions would add a new emissions source, referred to as "other large release events," to capture large emissions events that are not accurately accounted for using existing methods in GHGRP subpart W. The EPA also proposed calculation methodologies to improve the accuracy of reported emissions, incorporate additional empirical data, and allow owners and operators of applicable facilities to submit empirical emissions data that could appropriately demonstrate the extent to which a charge is owed in implementation of

CAA section 136, as directed by CAA section 136(h). The EPA also proposed revisions to existing reporting requirements to collect data that would improve verification of reported data, ensure accurate reporting of emissions, and improve the transparency of reported data. Additionally, the EPA proposed revisions that would align GHGRP subpart W with other EPA programs and regulations, including proposing revisions to certain requirements in GHGRP subpart W relative to the requirements proposed for NSPS OOOOb and the presumptive standards proposed in EG OOOOc (such that, as applicable, facilities would use a consistent method to demonstrate compliance with multiple EPA programs once their emission sources are required to comply with either the final NSPS OOOOb or an approved state plan or applicable Federal plan in 40 CFR part 62).

CAA section 136(c) directs the Administrator of the EPA to "impose and collect a charge on methane emissions that exceed an applicable waste emissions threshold under subsection (f) from an owner or operator of an applicable facility that reports more than 25,000 metric tons of carbon dioxide equivalent (CO₂ Eq.) of GHG emitted per year pursuant to subpart W of part 98 of title 40 (40 CFR part 98), regardless of the reporting threshold under that subpart" (hereinafter, waste emissions charge). An "applicable facility" is defined under CAA section 136(d) to include nine specific industry segments as defined in GHGRP subpart W. Pursuant to CAA section 136(g), the waste emissions charge "shall be imposed and collected beginning with respect to emissions reported for calendar year 2024 and for each year thereafter."

CAA section 136(f) includes specific exemption from the waste emissions charge for certain applicable facilities that meet certain criteria, including what the EPA refers to as a "regulatory compliance exemption." Specifically, CAA section 136(f)(6)(A) states that "charges shall not be imposed pursuant to subsection (c) on an applicable facility that is subject to and in compliance with methane emissions requirements pursuant to subsections (b) and (d) of section 111 upon a determination by the Administrator that: (i) Methane emissions standards and plans pursuant to subsections (b) and (d) of section 111 have been approved and are in effect in all states with respect to the applicable facilities; and (ii) compliance with the requirements described in clause (i) will result in equivalent or greater emissions

reductions as would be achieved by the proposed rule of the Administrator entitled 'Standards of Performance for New, Reconstructed, and Modified Sources and Emissions Guidelines for Existing Sources: Oil and Natural Gas Sector Climate Review' (86 FR 63110; (November 15, 2021), if such rule had been finalized and implemented." Per CAA section 136(f)(6)(B), "if the conditions in clause (i) or (ii) of subparagraph (A) cease to apply after the Administrator has made the determination in that subparagraph, the applicable facility will again be subject to the charge under subsection (c) beginning in the first calendar year in which the conditions in either clause (i) or (ii) of that subparagraph are no longer met."

In the preamble to the December 2022 Supplemental Proposal, the EPA noted that implementation of CAA section 136 was outside the scope of the present rulemaking, and that the EPA intended to take one or more separate actions in the future to implement CAA section 136. However, the EPA requested comment on the criteria and approaches that the Administrator should consider in making the CAA section 136(f)(6)(A)(ii) "equivalency determination" in such separate future action. Consistent with our statements in the December 2022 Supplemental Proposal, the EPA is not taking any final actions to implement CAA section 136 in this action and these comments are therefore outside the scope of this final rule.

VII. Summary of Engagement With Pertinent Stakeholders

As part of the regulatory development process for this rulemaking, the EPA conducted extensive outreach with the public, states, Tribal nations, and a broad range of pertinent stakeholders in order to gather information from a variety of viewpoints. This engagement allowed the EPA to provide stakeholders with overviews of the November 2021 Proposal and the December 2022 Supplemental Proposal, and to explain to the public and pertinent stakeholders how to effectively engage in the regulatory process. Such outreach is consistent with several E.O.s that encourage the Federal government to have a robust public participation process in regulatory development, particularly for communities with EJ concerns. The EPA specifically identified a long list of stakeholders with which to engage throughout the rulemaking process—including, but not limited to, industry, small businesses, Tribal nations, and

communities most affected by, and vulnerable to, the impacts of the rule.¹⁶⁰

Prior to the November 2021 Proposal, the EPA opened a public docket for pre-proposal input.¹⁶¹ Throughout the rulemaking, the EPA engaged with pertinent stakeholders likely to be interested in this rulemaking in several ways, including through meetings, training webinars, round tables, public listening sessions, and a technical workshop. For example, the EPA hosted a two-part webinar training specifically targeted toward both communities with EJ concerns and Tribal nations on November 16 and 17, 2021. The purpose of this training event was for the EPA to facilitate stakeholder panel discussions and to provide background information and an overview of the November 2021 Proposal, as well as information on how to effectively engage in the regulatory process. Subsequently, on November 14, 2022, the EPA hosted a call for environmental groups and EJ communities; on November 17, 2022, the EPA held a webinar for both members of Tribal nations and communities; and on November 30, 2022, the EPA held a training for Tribal Environmental Professionals. In a second example, the EPA held a training for small businesses on May 25, 2021, November 18, 2021, and November 30, 2022, that provided an overview of how the oil and natural gas industry is regulated and offered information on how to participate in the rulemaking process. In a third example, the EPA held calls with the Association of Air Pollution Control Agencies and the National Association of Clean Air Agencies on December 6, 2022, and December 14, 2022. In addition, on November 14, 2022, the EPA held a meeting with industry and labor groups to provide an overview of the proposed supplemental changes to the rulemaking. Throughout the rulemaking process the EPA has met individually with hundreds of industry representatives, NGOs, technology vendors, academics, data companies, and others.¹⁶² The EPA held 3-day virtual public hearings for all stakeholders on both the November 2021 Proposal and the December 2022 Supplemental Proposal.

The EPA notes that the implementing regulations (40 CFR part 60, subpart Ba) require states to include a description of

how they have engaged with pertinent stakeholders in the development of their state plans implementing the EG in their state plan submission to the EPA (to implement EG OOOOc). The EPA has led by example and demonstrated various examples of engagement with pertinent stakeholders so that states—while not limited by the EPA's outreach examples—will have a model for how they can structure their own outreach. For additional discussion on meaningful engagement as related to the development of state plans implementing the EG, please see section XIII.C.6 of this preamble.¹⁶³

VIII. Overview of Control and Control Costs

A. Control of Methane and VOC Emissions in the Crude Oil and Natural Gas Source Category—Overview

As described in the November 2021 Proposal and the December 2022 Supplemental Proposal, the EPA reviewed the standards in the 2012 NSPS OOOO and 2016 NSPS OOOOa pursuant to CAA section 111(b)(1)(B). Based on this review, the EPA is finalizing revisions to the standards for a number of affected facilities to reflect the updated BSEr for those affected facilities. Where our analyses show that the BSEr for an affected facility remains the same, the EPA is finalizing to retain the current standard for that affected facility. In addition to the review of the existing standards, the EPA is finalizing new standards for GHGs (in the form of limitation on methane) and VOCs for some sources that were previously unregulated under NSPS OOOO and NSPS OOOOb would apply to new, modified, and reconstructed emission sources across the Crude Oil and Natural Gas source category for which construction, reconstruction, or modification is commenced after December 6, 2022.

Further, pursuant to CAA section 111(d), the EPA is finalizing EG, which include presumptive standards for GHGs (in the form of limitations on methane) (designated pollutant), for certain existing emission sources across the Crude Oil and Natural Gas source category in EG OOOOc. While the requirements in NSPS OOOOb would apply directly to new sources, the requirements in EG OOOOc are for states to use in the development of plans that establish standards of

performance that will apply to existing sources (designated facilities).

B. How does the EPA evaluate control costs in this final action?

Section 111 of the CAA requires the EPA to consider a number of factors, including cost, in determining “the best system of emission reduction . . . adequately demonstrated.” CAA section 111(a)(1). The D.C. Circuit has long recognized that “[CAA] section 111 does not set forth the weight that [] should [be] assigned to each of these factors;” therefore, “[the court has] granted the agency a great degree of discretion in balancing them.” *Lignite Energy Council v. EPA*, 198 F.3d 930, 933 (D.C. Cir. 1999). The courts have recognized that the EPA has “considerable discretion under [CAA] section 111,” *id.*, on how it considers cost under CAA section 111(a)(1). As the Supreme Court has more recently noted, “[i]t will be up to the Agency to decide (as always, within the limits of reasonable interpretation) how to account for cost.” *Michigan v. EPA*, 576 U.S. 743, 759 (2015). A more detailed description of relevant case law guiding the EPA's consideration of costs is set forth in section IV.A of this document and in the November 2021 Proposal. See 86 FR at 63133, 63154 (November 15, 2021). For the purposes of this final rule, we use the term “reasonable” to describe costs which, based on our evaluation, are considered to be well within the boundaries of our discretion granted by Congress and recognized by the courts.

As explained in further detail below, the EPA has determined that the costs of controls associated with the BSEr for the final NSPS OOOOb and EG OOOOc are reasonable. In reaching this determination, the EPA conducted numerous cost analyses, described in detail in section XII of the November 2021 Proposal, Section IV of the December 2022 Supplemental Proposal, and section XI of this preamble—all of which discuss the BSEr determinations for each of the regulated emissions sources—and in the final rule TSD in the docket for this rulemaking.

In evaluating whether the cost of a control is reasonable, the EPA considers various associated costs, including capital costs and operating costs, when evaluating the BSEr for each emission source. In addition, as discussed further below, the Agency considered the costs of the collective standards for the final NSPS OOOOb and EG OOOOc in the context of the industry's overall capital expenditures and revenues. As discussed in more detail below, the capital expenditures in pollution control estimated to result from this

¹⁶⁰ For a list of the EPA's engagement with pertinent stakeholders, please see Memorandum in EPA-HQ-OAR-2021-0317.

¹⁶¹ EPA Document ID No. EPA-HQ-OAR-2021-0317-0295.

¹⁶² See various stakeholder meeting memoranda reflected in EPA's Docket ID No. EPA-HQ-OAR-2021-0317.

¹⁶³ To better inform this final rulemaking, the EPA analyzed the characteristics of communities with EJ concerns. Please see the discussion in section XVI.F of this preamble and the RIA for additional information.

rulemaking represent 2–3 percent of the industry’s annual capital expenditures. The estimated total annual expenditures represent less than one percent of the industry’s annual revenue. Neither estimate includes increased industry revenue from the sales of captured gas resulting from pollution controls, which offsets some of these costs. At the same time, this rulemaking is estimated to reduce 58 million short tons of methane from 2024 to 2038—representing a 79 percent reduction in projected emissions from the sources covered in this rulemaking.¹⁶⁴

As discussed in more detail in the November 2021 Proposal, see 86 FR 63154–7 (November 15, 2021), the EPA also considers a cost effectiveness analysis to be a useful metric, as it provides a means of evaluating whether a given control achieves emissions reduction at a reasonable cost and allows comparisons of relative costs and outcomes (effects) of two or more options. Cost effectiveness also provides a means of assessing consistency across rules regulating, and sectors regulated for, the same pollutant. In the context of an air pollution control option, cost effectiveness typically refers to the annualized cost of implementing an air pollution control measure divided by the amount of pollutant reductions realized annually. Notably, a cost effectiveness analysis is not intended to constitute or approximate a benefit-cost analysis in which monetized benefits are compared to costs, but rather is intended to provide a metric to compare the relative cost of emissions reductions. As explained in further detail in the November 2021 Proposal and the December 2022 Supplemental Proposal, the EPA estimated the cost effectiveness values of the various control options assessed for this rulemaking using the best information available to the Agency. The sources upon which the EPA relied in assessing cost effectiveness are described in detail in the TSDs and include studies by academia, non-governmental organizations, and state and Federal agencies. The EPA also relied upon costs and emissions data, as well as information related to technical limitations, submitted by members of the affected industry, including oil and gas production companies, and control device vendors and numerous other

¹⁶⁴ The percent reduction is calculated as the ratio of the sum of estimated emissions reductions for the NSPS from 2024–2038 and for the EG from 2028–2038 to the sum of estimated baseline emissions for the NSPS from 2024–2038 and for the EG from 2028–2038.

stakeholders,¹⁶⁵ in the form of public comments in this rulemaking and previous rulemakings. The EPA also relied upon financial information provided by industry organizations that represent small businesses, such as the Michigan Oil & Gas Association (MOGA).¹⁶⁶

The EPA used two approaches to determine cost effectiveness in this rulemaking. The first approach—the “single-pollutant cost effectiveness approach”—assigns all costs to the emission reduction of one pollutant and zero costs to all other concurrent reductions; where the cost of the control is reasonable for reducing any of the targeted pollutants alone, the cost is reasonable for all concurrent emissions reductions (because these additional pollutants are reduced at no additional cost). The second approach—the “multipollutant cost effectiveness approach”—apportions annualized cost of all pollutant reductions achieved by the control option in proportion to the relative percentage reduction of each pollutant controlled. A more detailed explanation of these approaches is set forth at 86 FR 63154–56 (November 15, 2021) and 87 FR 74718–19 (December 6, 2022).

As such, in the individual BSER analyses set forth in further detail section XII of the November 2021 Proposal, Section IV of the December 2022 Supplemental Proposal, and section XI of this preamble, for each control required in the final NSPS OOOOb, if a device is cost-effective under either of these two approaches, it is considered cost-effective. For EG OOOOc, which regulates only methane, a control is considered reasonable if it is cost-effective under the single-pollutant cost effectiveness approach. In addition to evaluating the annual average cost effectiveness of a control option, the EPA also considered the incremental costs associated with increasing the stringency of emissions standards in determining the appropriate level of stringency. See 86 FR 63156 (November 15, 2021) and 87 FR 74718–19 (December 6, 2022) for further details on incremental cost effectiveness analysis.

The EPA provides the cost effectiveness estimates for reducing VOC and methane emissions for various control options considered in the November 2021 Proposal and the

¹⁶⁵ For a more detailed summary of engagement and pertinent stakeholders that the EPA has engaged with, please see section VII of this preamble.

¹⁶⁶ See section XVII.C. of this preamble for summary of the EPA’s final regulatory flexibility analysis (FRFA) for this action.

December 2022 Supplemental Proposal, as well as in section XI of this preamble and associated TSDs. With respect to VOC emissions, the EPA finds that cost effectiveness values up to \$5,540/ton of VOC reduction are reasonable for controls that we have identified as BSER in the final NSPS OOOOb and EG OOOOc. These VOC values are within the range of what the EPA has historically considered to represent cost-effective controls for the reduction of VOC emissions, including in the 2016 NSPS, based on the Agency’s long history of regulating a wide range of industries.¹⁶⁷

For methane, the 2016 NSPS OOOOa was the first national standard for reducing methane emissions. Accordingly, at that time, the EPA considered a variety of information in evaluating whether the costs of control that would be imposed by the final NSPS and presumptive EG standards in this action are reasonable. As discussed in the November 2021 Proposal, the EPA previously determined that methane cost effectiveness values for the controls identified as BSER for the 2016 NSPS OOOOa, which ranged up to \$2,185/ton of methane reduction, represent reasonable costs for the industry as a whole to bear to reduce pollution. 86 FR 63155 (November 15, 2021). The reasonableness of the methane value selected in that rulemaking is reinforced by the fact that sources have been complying with the 2016 NSPS OOOOa for years without deleterious effect on the industry as a whole, which indicates that the NSPS OOOOa standards are not unduly burdensome from a cost perspective. The final standards in this rulemaking similarly reflect control mechanisms and measures that many companies and sources around the country are already implementing—again, without deleterious effect on industry as a whole—which shows not only that such controls are “adequately demonstrated” but also underscores their reasonableness from a cost perspective.

¹⁶⁷ The EPA has never established a bright line value with respect to cost effectiveness of VOC reductions under CAA section 111, because the cost effectiveness conclusions in individual rulemakings can be influenced by a variety of factors. Nonetheless, the cost effectiveness values determined to be reasonable for VOC reductions in this action are consistent with values the EPA has determined to be reasonable in actions for other industries. See, e.g., 88 FR 29978 (May 9, 2023) (finding control measures available at \$6,800/ton of VOC reduced reasonable for Automobile and Light Duty Truck Surface Coating Operations); 87 FR 35608 (June 10, 2022) (proposing to find control measures available for Bulk Gasoline Terminals with incremental cost effectiveness reasonable at \$4,020/ton of VOC reduced and unreasonable at \$8,300/ton of VOC reduced).

For methane, the controls that we have identified as BSER in the final NSPS OOOOb and EG OOOOc to be reasonable at cost-effectiveness values up to \$2,048/ton of methane reduction. The fact that the cost effectiveness estimates for the final standards in this action are comparable to (and in many individual instances, lower than) the cost effectiveness values estimated for the controls that served as the basis (*i.e.*, BSER) for the standards in the 2016 NSPS OOOOa, which have been in place for years, reinforces the conclusion that the final NSPS and presumptive standards in this rule are also cost-effective and reasonable.

As explained in further detail in the November 2021 Proposal, when determining the overall costs of implementation of the control technology and the associated cost effectiveness, the EPA takes into account cost savings from any natural gas recovered instead of vented as a result of the emissions controls. In our analysis, we consider any natural gas that is either recovered or not emitted as a result of a control option as being “saved;” we then apply the monetary value of the saved natural gas (estimated at \$3.13 per Mcf),¹⁶⁸ as an offset to the control cost. Notably, this offset does not apply where the owner or operator does not own the gas and would not likely realize the monetary value of the natural gas saved (*e.g.*, transmission stations and storage facilities). Detailed discussions of this approach are presented in section 2 of the RIA and at 86 FR 63156 (November 15, 2021).

We also updated the two additional analyses that the EPA performed for both the November 2021 Proposal and the December 2022 Supplemental Proposal to further inform our determination of whether the cost of control of the collection of standards would be reasonable, similar to compliance cost analyses we have completed for other NSPS.¹⁶⁹ The two additional analyses include: (1) a comparison of the capital costs incurred by compliance with the rulemaking to the industry’s estimated new annual capital expenditures, and (2) a comparison of the annualized costs that would be incurred by compliance with the final NSPS and presumptive EG

standards to the industry’s estimated annual revenues. In this section, the EPA provides updated information regarding these cost analyses based on the standards described in this document. See 86 FR 63156–7 (November 15, 2021) and 87 FR 74718–19 (December 6, 2022) for additional discussion on these two analyses. The results of both analyses, described in more detail in the following paragraphs, each independently demonstrate the reasonableness of the cost-effectiveness values applied in this final NSPS OOOOb and EG OOOOc, as well as demonstrate that the collective costs of the suite of final standards are reasonable in the context of the industry as a whole.

First, for the capital expenditures analysis, the EPA divided the nationwide capital expenditures projected to be spent to comply with the standards finalized in this rulemaking by an estimate of the total sector-level new capital expenditures for a representative year; this calculation shows the percentage that the nationwide capital cost requirements under the final standards represent of the total capital expenditures by the sector. The EPA combined the compliance-related capital costs under the final standards for NSPS OOOOb and for the presumptive standards in the final EG OOOOc in order to analyze the potential aggregate impact of the rulemaking. The equivalent annualized value (EAV) of the projected compliance-related capital expenditures over the 2024 to 2038 period is projected to be about \$2.5 billion in 2019 dollars. We obtained new capital expenditure data for relevant NAICS codes for 2018–2021 from the 2019, 2020, and 2021 editions of the U.S. Census Annual Capital Expenditures Survey.¹⁷⁰ According to these data, new capital expenditures for the sector ranged from \$79 billion in 2021 to \$156 billion in 2019 w in 2019 dollars.¹⁷¹ The wide range of annual expenditures across years are likely due to COVID–19-related impacts that dampened spending in 2020 and 2021. As such, while we conducted the analysis for all years from 2018 to 2021, we view the results for 2018 and 2019 as more representative of expected industry

outlays going forward. Note that new capital expenditures in 2019 for pipeline transportation of natural gas (NAICS 4862) includes only expenditures on structures because data on equipment expenditures are withheld to avoid disclosing data for individual enterprises. As a result, the 2019 capital expenditures used here represent an underestimate of the sector’s expenditures. Comparing the EAV of the projected compliance-related capital expenditures under this rule with the 2019 total sector-level new capital expenditures yields a percentage of about 1.6 percent, which is well below the percentage increase previously upheld by the courts as reasonable under CAA section 111. See detailed discussion at 86 FR 63156–7 (November 15, 2021) (citing *Essex Chem. Corp. v. Ruckelshaus*, 486 F.2d 427, 437–40 (D.C. Cir. 1973); *Portland Cement Ass’n v. Train*, 513 F.2d 506, 508 (D.C. Cir. 1975)). The same comparison for 2021 total sector-level new capital expenditures yields a percentage of about 3.2 percent.

Second, for the comparison of compliance costs to revenues, we used the EAV of the projected compliance costs both with and without projected revenues from product recovery under the rule for the 2024 to 2038 period, then divided the nationwide annualized costs by the annual revenues for the appropriate NAICS code(s) for a representative year in order to determine the percentage that the nationwide annualized costs represent of annual revenues. Like we do for capital expenditures, we combine the costs projected to be expended to comply with the standards for NSPS and the presumptive standards in the EG in order to analyze the potential aggregate impact of the rule. The EAV of the associated increase in compliance cost over the 2024 to 2038 period is projected to be about \$2.7 billion without revenues from product recovery and about \$1.7 billion with revenues from product recovery (in 2019 dollars). Revenue data for relevant NAICS codes were obtained from the U.S. Census 2017 County Business Patterns and Economic Census, the most recent revenue figures available.¹⁷² According to these data, 2017 receipts for the sector were about \$357 billion in 2019 dollars. Comparing the EAV of the projected compliance costs under the rulemaking with the sector-level

¹⁶⁸ This value reflects the forecasted Henry Hub price for 2022 from: U.S. Energy Information Administration. Short-Term Energy Outlook. <https://www.eia.gov/outlooks/steo/archives/may21.pdf>. Release Date: May 11, 2021.

¹⁶⁹ For example, see our compliance cost analysis in “Regulatory Impact Analysis (RIA) for Residential Wood Heaters NSPS Revision. Final Report.” U.S. Environmental Protection Agency, Office of Air Quality Planning and Standards. EPA–452/R–15–001, February 2015.

¹⁷⁰ U.S. Census Bureau, 2020 Annual Capital Expenditures Survey, table 4b. Capital Expenditures for Structures and Equipment for Companies with Employees by Industry: 2019 Revised. <https://www.census.gov/data/tables/2020/econ/aces/2020-aces-summary.html>, accessed July 12, 2022.

¹⁷¹ The total capital expenditures for the same NAICS codes during 2018 and 2020 were about \$154 billion and \$90 billion, respectively, in 2019 dollars.

¹⁷² 2017 County Business Patterns and Economic Census. The Number of Firms and Establishments, Employment, Annual Payroll, and Receipts by Industry and Enterprise Receipts Size: 2017. <https://www.census.gov/programs-surveys/susb/data/tables.2017.html>, accessed October 16, 2023.

receipts figure yields a percentage of about 0.8 percent without revenues from product recovery and about 0.5 percent with revenues from product recovery. More data and analysis supporting the comparison of capital expenditures and annualized costs projected to be incurred under the rule and the sector-level capital expenditures and receipts is presented in the TSD for this action, which is in the public docket.

Based on all of the cost-related information, data, and analyses described above, and as explained in further detail in the individual sections describing the BSER for each control in this preamble, the November 2021 Proposal, and the December 2022 Supplemental Proposal, the EPA concludes that the costs of the controls that serve as the basis for the final NSPS OOOOb and EG OOOOc are reasonable.

Some commenters have argued that the EPA was required to perform a cost-benefit analysis of this rulemaking demonstrating that the costs outweigh the benefits, and have cited the Supreme Court's decision in *Michigan v. EPA*, 576 U.S. 743 (2015) in support of this contention. One commenter¹⁷³ contends that the EPA's proposal is not reasonable if the climate benefits are illusory, and questions "[w]hat benefit-cost calculation makes the proposed regulatory surge a smart investment of public and private resources." The commenter also takes issue with the EPA's statement in the Supplemental Proposal that our "monetized benefits analysis is entirely distinct from the statutory BSER determinations proposed herein and is presented solely for the purposes of complying with E.O. 12866," 87 FR 74843. The commenter cites one excerpt from the Supreme Court's decision *Michigan* in support of its argument: "One would not say that it is even rational, never mind 'appropriate,' to impose billions of dollars in economic costs in return for a few dollars in health or environmental benefits . . . No regulation is 'appropriate' if it does significantly more harm than good." 576 U.S. at 752. Another group of commenters¹⁷⁴ quotes the same language from the case and asserts that the EPA must "balance the costs associated with government regulation against compliance costs," and that the November 2021 Proposed Rule "fails the cost-benefits test."

The EPA is mindful of the Supreme Court's holding in *Michigan* and has carefully considered how it applies to

this rulemaking. The EPA disagrees with the commenters insofar as they suggest that the EPA was required—under *Michigan* or any other authority—to undertake a formal cost-benefit analysis in this rulemaking. In *Michigan*, the Supreme Court concluded that the EPA erred when it concluded it could not consider costs when deciding whether it is "appropriate and necessary" under CAA section 112(n)(1)(A) to regulate hazardous air pollutants from electric utility steam generating units (power plants), despite the relevant statutory provision containing no specific reference to cost. 576 U.S. at 751. In doing so, the Court held that the EPA "must consider cost—including, most importantly, cost of compliance—before deciding whether regulation is appropriate and necessary" under CAA section 112. *Id.* at 759. In examining the language of CAA section 112(n)(1)(A), the Court concluded that the phrase "appropriate and necessary" was "capacious" and held that "[r]ead naturally in the present context, the phrase 'appropriate and necessary' requires at least some attention to cost." *Id.* at 752. This capaciousness was relevant in the context of section 112(n)(1)(A) because that section directs the EPA to determine "whether to regulate" the emission source, which is a context in which "[a]gencies have long treated cost as a centrally relevant factor." *Id.* at 753 (emphasis added).

The Supreme Court added in *Michigan* that it "need not and [does] not hold that the law unambiguously required the Agency, when making this preliminary estimate [of costs under the 'appropriate and necessary' standard of CAA 112(n)(a)(1)], to conduct a formal cost-benefit analysis in which each advantage and disadvantage is assigned a monetary value. It will be up to the Agency to decide (as always, within the limits of reasonable interpretation) how to account for cost." *Id.* at 759.

Section 111 differs in material respects from the provision the Supreme Court interpreted in *Michigan*. Unlike the circumstances at issue in *Michigan*, the predicate decision *whether* to regulate the emission source has already been made here. CAA section 111(b)(1)(A) requires the Administrator to list a source category "if, in his judgment, it causes or contributes significantly to, air pollution which may reasonably be anticipated to endanger public health or welfare." Notably, this provision does not hinge on a determination, like that under consideration in *Michigan* with respect to CAA section 112, that such listing is "appropriate and necessary." Indeed, the EPA has long regulated emissions

from the oil and gas source category, having first listed the source category in 1979. And once the EPA has listed a source category, CAA section 111(b)(1)(B) and (d)(1) require the EPA to promulgate new source performance standards and, for certain pollutants, emission guidelines for regulation of existing sources. Pursuant to this authority, the EPA has regulated VOC emissions since 1985 and GHG emissions (in the form of limitations on methane) since 2016. See section IV.B for further explanation of the regulatory history for the source category; and section V for further discussion of the EPA's authority to promulgate methane regulations.

Importantly, unlike the statutory provision at issue in *Michigan*, CAA section 111 already requires the EPA to consider costs when determining the appropriate level of control. Specifically, the "standards of performance" for new and existing sources finalized in this rule are "standard[s] for emissions of air pollutants which reflect[] the degree of emission limitation achievable through the application of the best system of emission reduction which (*taking into account the cost of achieving such reduction* and any nonair quality health and environmental impact and energy requirements) the Administrator determines has been adequately demonstrated." CAA section 111(a)(1) (emphasis added). Thus, even if the Court's examination of CAA 112(n)(a)(1) in *Michigan* did apply to CAA section 111—which the EPA disputes—the EPA's decision here, unlike in the rule reviewed in *Michigan*, is not blind to costs. Rather, the EPA has satisfied the Court's directive to consider costs, both in the context of the individual BSER analyses for individual emissions source (as directed by the language of the statute) and in the context of the rule as a whole. Moreover, while the EPA is not required to undertake a "formal cost-benefit analysis in which each advantage and disadvantage [of a regulation] is assigned a monetary value," *Michigan*, 576 U.S. at 759,¹⁷⁵ the EPA has contemplated and carefully considered both the advantages and disadvantages of the final NSPS OOOOb and EG OOOOc, including the qualitative and quantitative benefits of

¹⁷⁵ Accordingly, the EPA disagrees with the commenters that the EPA was required to demonstrate that the monetized benefits of the regulations outweigh the costs, and the EPA does not rely on the analysis of costs and benefits conducted to comply with E.O. 12866 for this purpose.

¹⁷³ Document ID No. EPA-HQ-OAR-2021-0317-2359.

¹⁷⁴ Document ID No. EPA-HQ-OAR-2021-0317-0790.

the regulation and the costs of compliance.

The primary disadvantage that the EPA has weighed in finalizing the NSPS OOOOb and EG OOOOc is the cost of compliance and the effects of those costs on industry. Notably, neither CAA section 111 nor *Michigan* directs that costs be considered in any particular way, and in this action, the EPA has considered costs using the same cost metrics that the EPA has historically used in numerous rulemakings under CAA section 111 for decades. As explained above, the EPA has used cost effectiveness as a metric to evaluate whether the costs associated with emissions reductions from a given technology are reasonable. This metric (widely used in environmental regulation) provides a way for the EPA to specifically consider the cost associated with each ton of reduction achieved by a particular control measure, and thereby determine whether the emission reductions achieved by the control measure are worthwhile, both as to the individual control measure in comparison to other available control measures, and in comparison to the regulation of the same pollutant in other industries. As explained in detail in section XI of this preamble, section XII of the November 2021 Proposal, and Section IV of the December 2022 Supplemental Proposal discussing the BSER determinations for each of the regulated emissions sources, the EPA has also considered costs in various other ways, including capital costs and operating costs, when evaluating the reasonableness of various control measures to determine the BSER.

In addition, the EPA conducted two cost analyses specifically for purposes of this action in order to evaluate the costs of compliance with the collective standards in the final NSPS OOOOb and EG OOOOc at a sector level and consider them in the context of the industry's overall capital expenditures and revenues. As explained in detail above, the EPA estimates that the capital costs expected to be incurred by compliance with the final NSPS OOOOb and EG OOOOc are about two to three percent of the industry's estimated new annual capital expenditures, and that the annualized compliance costs are less than one percent of the industry's estimated annual revenues. Notably, neither value includes increased industry revenue from the sales of captured gas resulting from pollution controls. Thus, while the industry will bear some costs to comply with the final NSPS OOOOb and EG OOOOc, each of these analyses supports the EPA's

determination that the costs associated with compliance with the final standards are reasonable and consistent with costs of control that the source category has expended for years to comply with existing state and Federal standards, and on voluntary actions to reduce emissions.

In terms of advantages, the final NSPS OOOOb and EG OOOOc will have numerous benefits to the climate, the natural environment, and human health through their projected reductions in methane and VOC emissions. Regarding methane, the oil and natural gas sector is the largest source of industrial methane emissions in the U.S. As described in greater detail in section III.B.2, it represents 28 percent of U.S. anthropogenic methane emissions and three percent of overall U.S. GHG emissions. Moreover, methane is a powerful and potent GHG—over a 100-year timeframe, it is nearly 30 times more powerful at trapping climate warming heat than CO₂, and over a 20-year timeframe, it is 83 times more powerful. Because it is particularly potent and emitted in large quantities, methane mitigation provides one of the best opportunities to reduce near-term warming and offers important climate benefits.

The projected methane emissions reductions from the final NSPS OOOOb and EG OOOOc standards, for each regulated emission source and taken together as a whole, will contribute to avoided climate and human health impacts, which are described in greater detail in section III.A.1 of this preamble, as well as in section III.A of the November 2021 Proposal. Warming temperatures in the atmosphere, ocean, and land have led to, for example: increased numbers of heat waves, wildfires, and other severe weather events; reduced air quality; more intense hurricanes and rainfall events; and sea level rise. These environmental changes, along with future projected changes, endanger the physical survival, health, economic well-being, and quality of life of people living in the U.S., particularly those in the most vulnerable communities. As discussed in greater detail in section III.A.1, impacts from climate change driven by GHG emissions are wide-ranging in type and scope, and present serious threats to human life and the natural environment. For example, severe weather events and natural disasters exacerbated by climate change—such as droughts, floods, storm surges, wildfires, and heat waves—affect food security, air quality and respiratory health, availability of fresh drinking water, population stability, national

security, participation in the workforce, and infrastructure and property, among many others. Other environmental impacts of climate change such as ocean acidification, altered plant growth, and increased concentrations of ozone also affect human health and well-being, in addition to that of the natural environment.

The final NSPS OOOOb and EG OOOOc standards are projected to reduce 58 million short tons of methane emissions from 2024 to 2038, which represents a 79 percent reduction in projected emissions from the sources covered in NSPS OOOOb and EG OOOOc. Accordingly, significantly reducing emissions of methane from the largest U.S. industrial source of this highly potent GHG will have meaningful climate benefits and environmental impacts, which will in turn have beneficial impacts on human health.

As described in more detail in section III.A.2, reducing VOC emissions will also benefit human health and the environment. The oil and natural gas sector represents the top anthropogenic U.S. sector for VOC emissions (after removing the biogenics and wildfire sectors), which is about 23 percent of total VOCs emitted by U.S. anthropogenic sources. See section III.B.2. VOCs can cause a variety of health concerns, including cancerous and noncancerous illnesses, particularly respiratory and neurological ones. VOCs are also one of the key precursors in the formation of ozone. Tropospheric, or ground-level, ozone is formed through reactions of VOC and NO_x in the presence of sunlight; ozone formation can be controlled to some extent through reductions in emissions of the ozone precursors VOC and NO_x. Health effects of ozone exposure include premature death from lung or heart diseases, as well as harmful symptoms and the development of asthma. Repeated exposure to ozone can also have harmful effects on sensitive plants and trees, which have the potential to impact ecosystems and the services they provide. The final NSPS OOOOb and EG OOOOc standards are projected to reduce 16 million short tons of VOC emissions from 2024–2038, which represent a 47 percent reduction in projected emissions from the sources covered in NSPS OOOOb and EG OOOOc.¹⁷⁶ Significant reductions in

¹⁷⁶ The percent reduction is calculated as the ratio of the sum of estimated emissions reductions for the NSPS from 2024–2038 and for the EG from 2028–2038 to the sum of estimated baseline emissions for the NSPS from 2024–2038 and for the EG from 2028–2038.

VOCs, like methane reductions, will have significant benefits to human health and the environment.

In consideration of all of this information, the EPA has concluded that, based on the totality of circumstances, the advantages that the rule provides—namely in the form of a substantial and meaningful reduction in methane and VOC pollution, and the associated positive impacts on public health and the natural environment (as discussed in detail in Section III.A)—outweigh its disadvantages, namely cost of industry compliance in the context of the industry's revenue and expenditures.

IX. Interaction of the Rules and Response to Significant Comments Thereon

A. What date defines a new, modified, or reconstructed source for purposes of the final NSPS OOOOb?

NSPS OOOOb would apply to all emissions sources (“affected facilities”) identified in the final 40 CFR 60.5365b that commenced construction, reconstruction, or modification after December 6, 2022.

Pursuant to CAA section 111(b), the EPA proposed NSPS for a wide range of emissions sources in the Crude Oil and Natural Gas source category in November 2021. Some of the proposed standards resulted from the EPA's review of the current NSPS codified at 40 CFR part 60 subpart OOOOa, while others were proposed standards for additional emissions sources that are currently unregulated. The emissions sources for which the EPA proposed standards in the November 2021 Proposal are as follows:

- Well completions
- Gas well liquids unloading operations
- Associated gas from oil wells
- Wet seal centrifugal compressors
- Reciprocating compressors
- Process controllers
- Pumps
- Storage vessels
- Collection of fugitive emissions components at well sites, centralized production facilities, and compressor stations
- Equipment leaks at natural gas processing plants
- Sweetening units

The EPA proposed standards for an additional emissions source, specifically dry seal centrifugal compressors, in the December 2022 Supplemental Proposal, while also providing numerous significant updates to the standards previously proposed in the November 2021 Proposal.

These final standards of performance apply to “new sources.” CAA section 111(a)(2) defines a “new source” as “any stationary source, the construction or modification of which is commenced after the publication of regulations (or, if earlier, proposed regulations) prescribing a standard of performance under this section which will be applicable to such source.” While the initial rulemaking proposing the standards for these emission sources was published November 15, 2021, due to many significant updates included in the December 2022 Supplemental Proposal, and the addition of dry seal centrifugal compressor proposed standards, the EPA is specifying that the “new sources” to which the final standards in NSPS OOOOb apply are those that commenced construction, reconstruction, or modification after December 6, 2022 (the date the supplemental proposal published in the **Federal Register**).

We received comments on the November 2021 Proposal that the proposal lacked regulatory text and therefore should not be used to define new sources for purposes of NSPS OOOOb.¹⁷⁷ The EPA disagrees that absence of a regulatory text in a proposal necessarily means that sources constructed after the date of the proposal cannot be “new sources” for purposes of an NSPS. Regardless, based on the unique facts and circumstances here, the EPA has concluded that only sources constructed, modified, or reconstructed after the date of the supplemental proposal should be considered new sources for the purposes of NSPS OOOOb.

On the unique facts and circumstances here, defining new sources based on the date of the supplemental proposal is consistent with CAA section 111(a)(2). That provision does not require the EPA to define new sources based on the date of the first proposal. Instead, CAA section 111(a)(2) states that a new source is “any stationary source, the construction or modification of which is commenced after the publication of regulations (or, if earlier, proposed regulations) prescribing a standard of performance under this section which will be applicable to such source.” The statute's general reference to “proposed regulations” gives the EPA discretion to determine which proposal (either an initial proposal or a supplemental proposal) should be used to define the universe of new sources in appropriate

circumstances. For the reasons stated above, it is reasonable based on the facts and circumstances of this rule to define the date for NSPS OOOOb based on the date of the supplemental proposal. These facts and circumstances include that the supplemental proposal included several updates to the proposed standards and rationale supporting those standards for many different sources, and that the supplemental proposal included new standards for a new source of emissions not addressed by the initial proposal. For example, in the December 2022 Supplemental Proposal, the EPA proposed changes to the proposed standards for fugitives at well sites, the use of alternative monitoring approaches for fugitives, pumps, and standards for dry seal centrifugal compressors. Having potentially differing dates for various new sources (e.g., one date for sources that the EPA did not propose changes in the December 2022 Supplemental Proposal and another date for sources that the EPA did propose changes to in the December 2022 Supplemental Proposal) that could be within the same facility would complicate the due dates for annual reporting. Having the same date for all sources at a facility will reduce burden on owners and operators to be able to have all annual reporting due simultaneously. Taken together, these facts support establishing the definition of new sources for purposes of NSPS OOOOb as those sources for which construction, modification, or reconstruction commenced after the date of the supplemental proposal.

Moreover, defining new sources as the EPA has described allows the EPA to establish a single new source definition for all NSPS OOOOb, which will streamline administration of the program for states and for the EPA. Because the supplemental proposal included proposed standards for certain sources not addressed in the initial proposal, if the EPA set the definition for new sources for NSPS OOOOb based on the dates upon which each of the standards were first proposed for each emissions source, the new source definition would run from the date of initial proposal for some sources of emissions, and the date of the supplemental proposal for others. Put another way, under that scenario, NSPS OOOOb would contain multiple definitions of “new source” which would differ from standard to standard. This complexity could make administration of the NSPS OOOOb unnecessarily cumbersome. Moreover, the time between the original November

¹⁷⁷ See Document ID Nos. EPA-HQ-OAR-2021-0317-0424, -0539, -0579, -0598, -0599, -0815, and -0929.

2021 Proposal and the December 2022 Supplemental Proposal was not vast. Within this single year, the EPA believes that a relatively modest number of sources commenced construction. While moving the applicability date for NSPS OOOOb does mean that these sources which commenced construction between the November 2021 Proposal and the December 2022 Supplemental Proposal will be considered “existing sources” for purposes of EG OOOOc instead of “new sources” under NSPS OOOOb, the EPA believes that this is an acceptable and preferred outcome when compared to the complexities associated with the alternative which are explained above. Notably, the EPA is also finalizing existing source EG in this action, which will ultimately require these sources to comply with standards of performance adopted in state plans under EG OOOOc.

B. What date defines an existing source for purposes of the final EG OOOOc?

The November 2021 Proposal and December 2022 Supplemental Proposal also included proposed emissions guidelines for states to follow to develop plans to regulate existing sources in the Crude Oil and Natural Gas source category under EG OOOOc. Under CAA section 111, relative to a particular NSPS, a source is considered either new, *i.e.*, construction, reconstruction, or modification commenced after a proposed NSPS is published in the **Federal Register** (CAA section 111(a)(2)), or existing, *i.e.*, any source other than a new source (CAA section 111(a)(6)). Accordingly, any source that is not subject to the proposed NSPS OOOOb as described is an existing source for purposes of EG OOOOc. As explained, the EPA is finalizing that for purposes of NSPS OOOOb new sources are those that commenced construction, reconstruction, or modification after December 6, 2022. Therefore, existing sources are those that commenced construction, reconstruction, or modification on or before December 6, 2022.

C. How will the final EG OOOOc impact sources already subject to NSPS KKK, NSPS OOOO, or NSPS OOOOa?

Sources currently subject to 40 CFR part 60, subpart KKK (NSPS KKK), 40 CFR part 60, subpart OOOO, or NSPS OOOOa would continue to comply with their respective VOC and methane standards until sources are subject to and in compliance with a state or Federal plan implementing EG OOOOc. While EG OOOOc specifically addresses methane and not VOC, any reductions from the methane standards established

in a state or Federal plan implementing EG OOOOc will similarly reduce VOCs. Therefore, the EPA concludes that the methane presumptive standards in EG OOOOc will result in the same or greater emission reductions than the VOC and methane standards in previous NSPS KKK, NSPS OOOO, or NSPS OOOOa. Once sources are subject to and in compliance with a state or Federal plan implementing EG OOOOc, and if that plan is just as stringent as or more stringent than the presumptive standards in EG OOOOc, the source will be deemed to comply with the previous respective VOC NSPS, and no longer subject to the methane NSPS, and will comply with only the state or Federal plan implementing EG OOOOc. Because the EG OOOOc does not contain SO₂ standards, sources subject to SO₂ standards in NSPS OOOO or NSPS OOOOa would continue to comply with their respective SO₂ standards unless they modify and become subject to the requirements in NSPS OOOOb.

In this rulemaking, the EPA is finalizing standards for dry seal centrifugal compressor and intermittent vent process controllers for the first time in NSPS OOOOb and presumptive standards in EG OOOOc. These designated facilities (*i.e.*, dry seal centrifugal compressors and intermittent vent process controllers) are not subject to regulation under a previous NSPS. The EPA is also finalizing presumptive standards in EG OOOOc for fugitive emissions at compressor stations, pumps at natural gas processing plants, and process controllers at natural gas processing plants that are all the same or more stringent than previous standards in NSPS KKK, NSPS OOOO, and NSPS OOOOa, as applicable. Additionally, the final presumptive standards in EG OOOOc for pumps (excluding processing) and natural gas processing plant equipment leaks are more stringent than the standards in NSPS OOOOa for pneumatic pumps and the standards in NSPS KKK, NSPS OOOO, and NSPS OOOOa for natural gas processing plant equipment leaks.

For wet seal centrifugal compressors, two different standards are in place in the previous NSPS. NSPS KKK is an equipment standard that provides several compliance options including: (1) Operating the compressor with the barrier fluid at a pressure that is greater than the compressor stuffing box pressure; (2) equipping the compressor with a barrier fluid system degassing reservoir that is routed to a process or fuel gas system, or that is connected by a CVS to a control device that reduces VOC emissions by 95 percent or more;

or (3) equipping the compressor with a system that purges the barrier fluid into a process stream with zero VOC emissions to the atmosphere. NSPS KKK exempts a compressor from these requirements if it is either equipped with a closed vent system to capture and transport leakage from the compressor drive shaft back to a process or fuel gas system or to a control device that reduces VOC emissions by 95 percent, or if it is designated for no detectable emissions (NDE). NSPS OOOO and NSPS OOOOa require 95 percent reduction of emissions from each centrifugal compressor wet seal fluid degassing system. NSPS OOOO and OOOOa also allow the alternative of routing the emissions to a process. For sources transitioning from NSPS KKK to EG OOOOc, the EPA is finalizing a subcategory for wet seal centrifugal compressors at onshore natural gas processing plants for which construction, reconstruction, or modification commenced after January 20, 1984, and on or before August 23, 2011. This subcategory will apply to all sources that were previously subject to NSPS KKK, and have EG OOOOc presumptive standards that are equivalent to NSPS KKK with three compliance options including: (1) operating the compressor with the barrier fluid at a pressure that is greater than the compressor stuffing box pressure; (2) equipping the compressor with a barrier fluid system degassing reservoir that is routed to a process or fuel gas system, or that is connected by a CVS to a control device that reduces methane emissions by 95 percent or more; or (3) equipping the compressor with a system that purges the barrier fluid into a process stream with zero methane emissions to the atmosphere. While EG OOOOc specifically addresses methane and not VOC, any reductions from the methane standards contained in this subcategory that reduce methane as established in a state or Federal plan implementing EG OOOOc will similarly reduce VOCs. Therefore, wet seal centrifugal compressors within this subcategory will only need to comply with a state or Federal plan implementing EG OOOOc and will then no longer need to comply with NSPS KKK. The EPA is not aware of any wet seal centrifugal compressors subject to NSPS OOOO or NSPS OOOOa, and the EPA believes that centrifugal compressors installed since those rules went into effect (August 2011 and September 2015) are utilizing dry seals rather than wet seals.

Similarly, there are two different standards for reciprocating compressors

in the previous NSPS: (1) NSPS KKK requires the use of a seal system and includes a barrier fluid system that prevents leakage of VOC to the atmosphere for reciprocating compressors located at natural gas processing plants, and (2) NSPS OOOO and NSPS OOOOa require changing out the rod packing every 3 years or routing emissions to a control. For sources transitioning from NSPS KKK to EG OOOOc, the EPA is finalizing a subcategory for reciprocating compressors at onshore natural gas processing plants for which construction, reconstruction, or modification commenced after January 20, 1984, and on or before August 23, 2011. This subcategory will apply to all sources that were previously subject to the VOC standards of NSPS KKK and have EG OOOOc presumptive standards that are equivalent to the VOC standards of NSPS KKK with the requirement of the use of a seal system and including a barrier fluid system that prevents leakage of methane to the atmosphere. Again, while EG OOOOc specifically regulates methane and not VOC, any methane standards contained in this subcategory that reduce methane as established in a state or Federal plan implementing EG OOOOc will similarly reduce VOCs. Therefore, reciprocating compressors within this subcategory will only need to comply with a state or Federal plan implementing EG OOOOc and will then no longer need to comply with NSPS KKK. For sources transitioning from NSPS OOOO and NSPS OOOOa, as previously explained in section XII.E.1.d of the November 2021 Proposal¹⁷⁸ and section IV.I of the December 2022 Supplemental Proposal, the EPA concludes that the final EG OOOOc presumptive methane standard is more efficient at discovering and reducing any emissions that may develop than the set 3-year replacement interval from NSPS OOOO and NSPS OOOOa. Overall, the final presumptive standards in EG OOOOc would result in more rod packing replacements, thereby reducing more emissions compared to the 3-year interval. Therefore, reciprocating compressors transitioning from NSPS OOOO and NSPS OOOOa only need to comply with a state or Federal plan implementing EG OOOOc, and will then be no longer needed to comply with NSPS OOOO or NSPS OOOOa.

The affected facility for storage vessels is defined in the NSPS OOOO and NSPS OOOOa as a single storage vessel with the potential to emit (PTE) greater than 6 tons of VOC per year and

the standard that applies is 95 percent emissions reduction. Under the final EG OOOOc, the designated facility is a tank battery with the PTE greater than 20 tons of methane per year with the same 95 percent emission reduction standard. Affected facilities under NSPS OOOO or OOOOa that are part of a designated facility under the EG presumptive standard would be required to meet the 95 percent reduction standard, and therefore only need to comply with a state or Federal plan implementing EG OOOOc and will then no longer need to comply with NSPS OOOO or OOOOa. Affected facilities under NSPS OOOO or OOOOa that emit 6 tpy or more of VOCs but that do not meet the PTE 20 tons of methane per year definition would continue to comply with the 95-percent emissions reduction standard in their respective NSPS. Scenarios regarding further physical or operational changes in NSPS OOOOb that would reclassify sources from the previous NSPS and/or EG OOOOc into NSPS OOOOb are discussed in section IV.J.1.b of this preamble.

Similarly, process controller affected facilities not located at natural gas processing plants are defined as single high-bleed controllers with a low-bleed standard under NSPS OOOO and NSPS OOOOa, while the designated facility under EG OOOOc is defined as a collection of natural gas-driven process controllers at a site with a zero-emissions standard (discussed further in section IV.D of this preamble). Because the final zero-emissions presumptive standard in EG OOOOc is more stringent than the low-bleed standard found in the previous NSPS, sources only need to comply with a state or Federal plan implementing EG OOOOc and will then no longer need to comply with NSPS OOOO and OOOOa (assuming the state or Federal plan implementing EG OOOOc is as stringent as the presumptive standard of zero emissions in the final EG).

Lastly, standards for fugitive emissions from well sites under NSPS OOOOa require semiannual OGI monitoring on all components at the well site except for wellhead only well sites (which are not affected facilities), while the presumptive standards under the final EG OOOOc would require quarterly OGI monitoring with bimonthly audible, visual, and olfactory (AVO) inspections at well sites with major production and processing equipment, semiannual OGI combined with quarterly AVO inspections at multi-wellhead only well sites,¹⁷⁹ and

quarterly AVO inspections for small sites and single wellhead well sites, as described in sections X and XI of this preamble. It is clear that the final presumptive standards in EG OOOOc for well sites with major production and processing equipment and the final presumptive standards for multi-wellheads only well sites are both more stringent than the semiannual OGI monitoring standard under NSPS OOOOa because one would require more frequent OGI monitoring while the other would require AVO inspections in addition to semiannual OGI monitoring. Therefore, these existing well sites only need to comply with a state or Federal plan implementing EG OOOOc and will then no longer need to comply with NSPS OOOOa. Likewise, as the EPA has concluded that the advanced methane detection technology periodic screening work practice being finalized in EG OOOOc is equivalent to the standard fugitive emissions work practice using OGI and AVO, the advanced methane detection technology periodic screening work practice being finalized in EG OOOOc is also more stringent than the OGI monitoring standard in NSPS OOOOa. In order to allow owners and operators to adopt implementation of these advanced methane detection technologies early, the EPA is finalizing in NSPS OOOOa an option for owners and operators to comply with the advanced methane detection technology work practices in NSPS OOOOb in lieu of the OGI surveys required in 40 CFR 60.5397a. The EPA recognizes that there are some differences between the definition of fugitive emissions component between EG OOOOc and NSPS OOOOa. In NSPS OOOOa, the EPA has clarified that if an owner or operator subject to NSPS OOOOa chooses to implement the advanced methane detection technology work practices in NSPS OOOOb the definitions in 40 CFR 60.5430b, which would include the definition of fugitive emissions component, apply for the purposes of the advanced methane detection technology work practice.

For existing single wellhead only well sites and small sites that are previously subject to the semiannual monitoring under NSPS OOOOa and transitioning to EG OOOOc, the EPA is concluding that, as explained in more detail in section IV.A of this preamble, AVO is effective, and therefore OGI is unnecessary, for detecting fugitive emissions from many of the fugitive emissions components at these sites. By

proposed EG OOOOc, some single and multi-wellhead only well sites could be subject to the semiannual OGI monitoring under NSPS OOOOa.

¹⁷⁹ Because of a difference in the definition of a wellhead only well site in NSPS OOOOa and the

¹⁷⁸ 86 FR 63215–20 (November 15, 2021).

requiring more frequent visits to the sites, the final presumptive standard in EG OOOOc would allow earlier detection and repair of fugitive emissions, in particular large emissions from components such as thief hatches on uncontrolled storage vessels. The EPA concludes that the final presumptive standards under the proposed EG OOOOc would effectively address the fugitive emissions at these well sites and that semiannual OGI monitoring would no longer be necessary for these well sites. Therefore, these sources need to comply with NSPS OOOOa until they are in compliance with a state or Federal plan implementing EG OOOOc. Once subject to and in compliance with such a plan, then they no longer need to comply with NSPS OOOOa.

X. Summary of Final Standards NSPS OOOOb and EG OOOOc

A. Fugitive Emissions From Well Sites, Centralized Production Facilities, and Compressor Stations

As described in section IV.A of the December 2022 Supplemental Proposal preamble (87 FR 74722, December 6, 2022) and section XI.A of the November 2021 Proposal preamble (86 FR 63169, November 15, 2021), fugitive emissions are unintended emissions that can occur from a range of components at any time due to leaks. Collectively, these emissions constitute one of the largest sources of methane from this source category, representing approximately 700 kt of the 2019 methane emissions from this source category reported in the GHGI. The magnitude of these emissions can also vary widely across different facilities and over time. The EPA has historically addressed fugitive emissions from the Crude Oil and Natural Gas source category through ground-based component level monitoring using OGI or EPA Method 21 of appendix A-7 to 40 CFR part 60.

This section of the preamble presents a summary of the final standards for NSPS OOOOb and final presumptive standards for EG OOOOc regarding fugitive emissions components affected facilities and designated facilities located at well sites, centralized production facilities, and compressor stations. As defined in the final NSPS OOOOb, a fugitive emissions component is “any component that has the potential to emit fugitive emissions of methane or VOC at a well site, centralized production facility, or compressor station, such as valves (including separator dump valves), connectors, pressure relief devices, open-ended lines, flanges, covers and

closed vent systems not subject to § 60.5411b, thief hatches or other openings on a storage vessel not subject to § 60.5395b, compressors, instruments, meters, and yard piping.”¹⁸⁰

1. Fugitive Emissions at Well Sites and Centralized Production Facilities

a. NSPS OOOOb

i. Affected Facility

The standards apply to each fugitive emissions components affected facility, which is the collection of fugitive emissions components at a well site or centralized production facility.

ii. Final Standards

In this final rule, the EPA is finalizing the work practice standards for monitoring and repairing (including replacing) fugitive emissions components at fugitive emissions components affected facilities located at well sites and centralized production facilities, as proposed in the December 2022 Supplemental Proposal. Specifically, the EPA is finalizing monitoring and repair programs for four subcategories of well sites as follows:

1. Single wellhead only well sites:

Quarterly AVO inspections,

2. Multi-wellhead only well sites: Semiannual OGI (or EPA Method 21) monitoring following the monitoring plan required in 40 CFR 60.5397b and quarterly AVO inspections,

3. Well sites with major production and processing equipment and centralized production facilities: Quarterly OGI (or EPA Method 21) monitoring following the monitoring plan required in 40 CFR 60.5397b and bimonthly AVO inspections, and

4. Small well sites: Quarterly AVO inspections.

The third subcategory includes well sites and centralized production facilities that have:

1. One or more controlled storage vessels or tank batteries,

2. One or more control devices,

3. One or more natural gas-driven process controllers or pumps, or

4. Two or more pieces of major production or processing equipment not listed in items 1–3.

The EPA explained in the December 2022 Supplemental Proposal that it was proposing to define this third subcategory as such (in particular items 1–3 above) “because those sources individually are known sources of super-emitter emissions events (see section IV.C) and are subject to quarterly

¹⁸⁰The definition of a fugitive emissions component in EG OOOOc is the same except for the reference to 60.5411c instead of 60.5411b and 60.5396c instead of 60.5395b.

OGI for compliance assurance (storage vessels and pneumatic controllers) or are subject to other continuous monitoring requirements (control devices).”¹⁸¹ As discussed in section XI.D.3 of this preamble, we have changed the terminology from “pneumatic controllers” to “process controllers” in the final rule.

Also, as explained in the December 2022 Supplemental Proposal, the fourth subcategory, small well sites, includes single wellhead well sites that do not contain any controlled storage vessels, control devices, natural gas-driven process controllers, or natural gas-driven pumps and contain only one piece of certain major production and processing equipment. Major production and processing equipment that would be allowed at a small well site would include a single separator, glycol dehydrator, centrifugal or reciprocating compressor, heater/treater, or a storage vessel that is not controlled. *Id.* at 74723.

For the second subcategory, multi-wellhead only well sites, where semiannual OGI monitoring is required, subsequent semiannual monitoring would be required to occur at least 4 months apart and no more than 7 months apart. For the third subcategory, well sites with major production and processing equipment and centralized production facilities, where quarterly OGI monitoring is required, subsequent quarterly monitoring would occur at least 60 days apart. Quarterly OGI monitoring may be waived when temperatures are below 0 °F for two of three consecutive calendar months of a quarterly monitoring period.

In the final rule, the EPA clarified that the monitoring requirements for fugitive emissions components do not apply to buried yard piping and associated buried fugitive emissions components (e.g., buried connectors on the buried yard piping).

In addition to clarifying in the fugitive emissions component definition that “valves” include dump valves, the EPA specifies in the final rule the requirement to visually inspect the separator dump valve while at the site conducting regular AVO monitoring surveys (either quarterly or bimonthly, depending on the site) to ensure that it is operating as designed and not stuck in an open position. As proposed in the December 2022 Supplemental Proposal, the EPA is also finalizing the closed and sealed requirement for thief hatches or other openings (on storage vessels or tank batteries) that are fugitive emissions components and the

¹⁸¹ 87 FR 74735.

requirement to visually inspect the hatch to confirm compliance during the AVO monitoring survey.

The EPA is finalizing the following repair timelines. A first attempt at repair of malfunctioning separator dump valves, open or unsealed thief hatches and other storage vessel openings, or other sources of fugitive emissions identified with AVO must be made within 15 days after the detection, with final repair required within 15 days after the first attempt. A first attempt at repair of the source of fugitive emissions identified with OGI or EPA Method 21 must be made within 30 days after the detection, with final repair required within 30 days after the first attempt. The EPA is also finalizing provisions to allow a delay of repair if the repair is technically infeasible, would require a vent blowdown, well shutdown, or well shut-in, would be unsafe to repair during operation of the unit, or would require replacement parts that are unavailable for certain reasons (see section XI.A.1.e for details); in no case is delay allowed beyond 2 years.

Monitoring surveys of fugitive emissions components affected facilities at a well site or centralized production facility must continue until the site or facility is permanently closed following the required well closure plan. After all well closure activities are completed, a final OGI survey of the site must be conducted (and recorded in the well closure plan) and any emissions detected must be eliminated.

iii. Recordkeeping and Reporting Requirements

The final rule requires specific recordkeeping and reporting requirements for each fugitive emissions components affected facility located at a well site or centralized production facility. The recordkeeping requirements closely follow those in the December 2022 Supplemental Proposal but incorporate the addition of new delay of repair recordkeeping requirements. In the case of delay of repair due to parts unavailability, operators must document the date the leak was added to the delay of repair list, the date the replacement fugitive emissions component or part thereof was ordered, the anticipated delivery date, and the actual delivery date.

The reporting requirements are unchanged from the December 2022 Supplemental Proposal. Sources would be required to report the designation of the type of site (*i.e.*, well site or centralized production facility) at which the fugitive emissions components affected facility is located. In addition, for each fugitive emissions components

affected facility that becomes an affected facility during the reporting period, the date of the startup of production or the date of the first day of production after the modification would be required to be reported for well sites or centralized production facility. Each fugitive emissions components affected facility at a well site would also be required to specify in the annual report what type of site it is (*i.e.*, a single wellhead only well site, small well site, a multi-wellhead only well site, or a well site with major production and processing equipment) and to report information on changes such as the removal of all major production and processing equipment or well closure activities during the reporting period.

For fugitive emissions components affected facilities located at well sites and centralized production facilities, the following information is required to be included in the annual report for fugitive emissions monitoring surveys conducted using AVO, OGI, or Method 21:

- Date of the survey,
- Monitoring instrument or, if the survey was conducted using AVO, notation that AVO was used,
- Any deviations from key monitoring plan elements or a statement that there were no deviations from these elements of the monitoring plan,
- Number and type of components for which fugitive emissions were detected,
- Number and type of fugitive emissions components that were not repaired as required,
- Number and type of fugitive emissions components (including designation as difficult-to-monitor or unsafe-to-monitor, if applicable) on delay of repair and explanation for each delay of repair, and
- Date of planned shutdown(s) that occurred during the reporting period if there are any components that have been placed on delay of repair.

For fugitive emissions components affected facilities located at well sites and centralized production facilities complying with an alternative fugitive emissions standard under 40 CFR 60.5399b, the annual report must identify the alternative standard and include either the site-specific report or the same information described above. For fugitive emissions components affected facilities located at well sites and centralized production facilities complying with an alternative fugitive emissions standard under 40 CFR 60.5398b, the annual report must include information specified in 40 CFR 60.5424b.

b. EG OOOOc

i. Designated Facility

These final EG define designated facilities as the collection of fugitive emissions components at a well site or a centralized production facility.

ii. Final Presumptive Standards

The presumptive methane standards for existing sources under EG OOOOc are the same as the methane standards for new sources under NSPS OOOOb.

2. Fugitive Emissions at Compressor Stations

a. NSPS OOOOb

i. Affected Facility

The standards apply to each fugitive emissions components affected facility, which is the collection of fugitive emissions components at a compressor station.

ii. Final Standards

In this final rule, the EPA is finalizing the quarterly OGI (or EPA Method 21) monitoring requirement for fugitive emissions components affected facilities located at compressor stations, as proposed in the December 2022 Supplemental Proposal. Specifically, the EPA is finalizing the requirement that quarterly surveys be performed using OGI or EPA Method 21 following the monitoring plan required in the final regulatory text at 40 CFR 60.5397b. The EPA is also finalizing the requirement to conduct monthly AVO monitoring at compressor stations. Any indications of fugitive emissions identified via AVO would be subject to repair requirements.

The EPA is also finalizing the repair timelines proposed in the December 2022 Supplemental Proposal. A first attempt at repair of the source of fugitive emissions identified with AVO must be made within 15 days after the detection, with final repair required within 15 days after the first attempt. A first attempt at repair of the source of fugitive emissions identified with OGI or EPA Method 21 must be made within 30 days after the detection, with final repair required within 30 days after the first attempt. The EPA is also finalizing provisions to allow a delay of repair if the repair is technically infeasible, would require a vent blowdown, a compressor station shutdown, a well shutdown or well shut-in, would be unsafe to repair during operation of the unit, or would require replacement parts that are unavailable for certain reasons (see section XI.A.2.b for details); in no case is delay allowed beyond 2 years.

The final rule for fugitive emissions components affected facilities located at

compressor stations includes the requirement that consecutive quarterly monitoring surveys be conducted at least 60 days apart. As proposed, the EPA is finalizing the provision that the quarterly OGI monitoring may be waived when temperatures are below 0 °F for 2 of 3 consecutive calendar months of a quarterly monitoring period.

iii. Recordkeeping and Reporting Requirements

The final rule requires specific recordkeeping and reporting requirements for each fugitive emissions components affected facility. The recordkeeping requirements closely follow those in the December 2022 Supplemental Proposal but incorporate the addition of new delay of repair recordkeeping requirements. In the case of delay of repair due to parts unavailability, operators must document the date the leak was added to the delay of repair list, the date the replacement fugitive emissions component or part thereof was ordered, the anticipated delivery date, and the actual delivery date.

The reporting requirements are unchanged from the December 2022 Supplemental Proposal. Sources would be required to report the designation of the type of site (*i.e.*, compressor station) at which the fugitive emissions components affected facility is located. For fugitive emissions components affected facilities located at compressor stations, the following information is required to be included in the annual report for monthly surveys conducted using AVO, OGI, or Method 21:

- Date of the survey,
- Monitoring instrument or, if the survey was conducted using AVO, notation that AVO was used,
- Any deviations from key monitoring plan elements or a statement that there were no deviations from these elements of the monitoring plan,
- Number and type of components for which fugitive emissions were detected,
- Number and type of fugitive emissions components that were not repaired as required,
- Number and type of fugitive emissions components (including designation as difficult-to-monitor or unsafe-to-monitor, if applicable) on delay of repair and explanation for each delay of repair, and
- Date of planned shutdown(s) that occurred during the reporting period if there are any components that have been placed on delay of repair.

For fugitive emissions components affected facilities located at compressor stations complying with an alternative

fugitive emissions standard under 40 CFR 60.5399b, the annual report must identify the alternative standard and include either the site-specific report or the same information described above. For fugitive emissions components affected facilities located at compressor stations complying with an alternative fugitive emissions standard under 40 CFR 60.5398b, the annual report must include information specified in 40 CFR 60.5424b.

b. EG OOOOc

i. Designated Facility

These final EG define designated facilities as the collection of fugitive emissions components at a compressor station.

ii. Final Presumptive Standards

The presumptive methane standards for existing sources under EG OOOOc are the same as the methane standards for new sources under NSPS OOOOb.

B. Advanced Methane Detection Technology Work Practices

The EPA has included the use of advanced methane detection technologies in this final rule, in recognition of the rapid and continued advancement of these technologies and their current use by owner or operators to supplement their existing ground based OGI surveys and AVO inspections. Industry has applied many such technologies, from on-site sensor networks to aerial flyovers using remote sensing technology that can screen hundreds of sites in a single deployment, to efficiently detect methane emissions at a variety of facilities and focus their methane mitigation efforts. In the November 2021 Proposal, we proposed to allow owners and operators to undertake an approach with bimonthly periodic screening events using these technologies as an alternative to periodic OGI surveys. In doing so, the EPA acknowledged that these advanced methane detection technologies have important advantages, including the ability to detect fugitive emissions quickly and cost-effectively in a manner that may be less susceptible to operator error or judgement than traditional leak detection technologies. Because many of these advanced methane detection technologies are designed to scan multiple sites at once, owners and operators have used them as an effective “screening” tool to rapidly identify particular high-emitting sites that warrant targeted inspection and repair efforts.

The inclusion of these advanced methane detection technologies in NSPS OOOOb and EG OOOOc received

widespread support from stakeholders. We also received feedback on how the EPA could improve on its proposal and expand this approach to maximize its efficacy in reducing methane emissions and its utility as a compliance flexibility for owners and operators. In the December 2022 Supplemental Proposal, we provided additional flexibility for advanced methane technologies using the periodic screening approach by allowing the frequency of the surveys to vary according to the sensitivity of the technology used, instead of requiring the same frequency of monitoring for all technologies (*i.e.*, periodic screening surveys performed with technologies with lower detection thresholds would need to be performed less frequently than screening surveys performed with technologies with higher detection thresholds). We also introduced a separate alternative work practice using continuous methane monitoring systems. Finally, we proposed a streamlined approach to approving new technology that is similar to our current alternative test method approval process. This approach ensures that the advanced methane detection technologies used to conduct periodic screening or continuous monitoring will provide consistent and reliable information for emission reductions, while also allowing an easier pathway for owners and operators to adopt the use of the technologies. We believe that this approach will continue to incentivize the continued development and improvement of these technologies, thus leading to even greater emission reductions.

This section summarizes the final provisions in NSPS OOOOb and in the model rule implementing EG OOOOc for the use of advanced methane detection technologies in lieu of OGI and/or AVO at well sites, centralized production facilities, and compressor stations. As described here, the EPA is finalizing a compliance option that would allow the use of these advanced methane detection technologies as an alternative to the use of ground-based OGI surveys, EPA Method 21 (which the final rule continues to allow as an alternative to OGI), and AVO inspections to identify emissions from the collection of fugitive emissions components located at well sites, centralized production facilities, and compressor stations. In response to comments received on the December 2022 Supplemental Proposal, the EPA has made revisions and clarifications to the periodic screening approach, continuous monitoring provisions, and alternative test method process for

approving advanced methane detection technologies for use in these work practices.

1. Periodic Screening

In this final rulemaking, the EPA is expanding the proposed alternative periodic screening approach to provide more flexibility in selection of appropriate advanced methane detection technology and to account for the spatial resolution of these technologies. The EPA has also re-evaluated the equivalency modeling from the December 2022 Supplemental Proposal used to develop the screening frequency matrix and is finalizing revisions to these tables to account for uncertainty in the models as discussed in the revised Supplemental TSD Fugitive Emissions Abatement Simulation Toolkit (FEAST) Memo.¹⁸² The updated periodic screening frequency matrices are specified in tables 3 and 4 of the final NSPS OOOOb and the model rule implementing the final EG OOOOc. The EPA is also finalizing an interim periodic screening option that will expire on March 9, 2026. See section XI.B.1 of this preamble for more information on this interim periodic screening matrix.

For periodic screening using advanced methane detection technology, the final rules provide greater flexibility by allowing the owner or operator to utilize multiple detection technologies in combination, instead of requiring the owner or operator to choose one technology. This approach will allow end-users to optimize their periodic screening program by choosing the most suitable technology based on time of year and availability of technology providers. The periodic screening frequency will be based on the technology with the highest aggregate detection threshold that the owner or operator lists as a technology they plan to use in their monitoring plan (*e.g.*, if you use methods with aggregate detection thresholds of 15 kg/hr, your periodic screenings must be conducted monthly). The final rule also allows an owner or operator to replace any periodic screening survey with an OGI survey.

This final rulemaking will require owners and operators to develop a monitoring plan, which can be site-specific or cover multiple sites. The monitoring plan must contain the following information at a minimum, consistent with the December 2022 Supplemental Proposal:

- Identification of each site, including latitude and longitude;
- Identification of the alternative test methods(s) used (*i.e.*, advanced methane detection technology) and required frequency;
- Contact information of the entities performing the screening;
- Procedures for conducting OGI surveys;
- Procedures for identifying and repairing fugitive emissions components, covers, and closed vents systems when emissions are detected; and
- Procedures for verifying repairs of fugitive emissions components, covers, and closed vents system.

The final rulemaking finalizes the proposed timeframe in the December 2022 Supplemental Proposal that an owner or operator must initiate periodic screenings using advanced methane detection technology, within 90 days after startup or modification of a fugitive emissions components affected facility and storage vessel affected facility at new, modified, or existing well sites, centralized production facilities, and/or compressor stations, as well as timeframes for initiating periodic screenings if an owner or operator opts to switch to periodic screenings at a later time (*i.e.*, the owner or operator was originally conducting fugitive emissions surveys with OGI or EPA Method 21). The final rule also sets timeframes for conducting annual OGI surveys, if an owner or operator is required to do so based on the periodic screening matrix.

The final rulemaking finalizes the requirement in the December 2022 Supplemental Proposal that owners and operators must receive the data from a periodic screening event within 5 calendar days. If the screening event indicates a confirmed detection, the owner or operator must conduct follow-up monitoring. In the final rule, we are allowing a more targeted follow-up survey, dependent on the spatial resolution of the advanced methane detection technology used during the periodic screening event. The final rulemaking includes three different classifications for spatial resolution: facility-level, which must be able to identify emissions within the boundary of a well site, centralized production facility, or compressor station; area-level, which must be able to identify emissions within a radius of 2 meters of the emission source; and component-level, which must be able to identify emissions within a radius of 0.5 meters of the emission source. The follow-up monitoring that must be conducted for a confirmed detection during a periodic

screening event using a technology with facility-level spatial resolution includes:

- A monitoring survey of all the fugitive emissions components in an affected facility using either OGI or EPA Method 21;
- Inspection of all covers and closed vent systems of the affected facility with either OGI or EPA Method 21; and
- Visual inspection of all closed vent systems and covers to identify if there are any defects.

The follow-up monitoring that must be conducted for a confirmed detection during a periodic screening event using a technology with area-level spatial resolution includes:

- A monitoring survey of all the fugitive emissions components located within a 4-meter radius of the location of the confirmed detection using either OGI or EPA Method 21; and
- If the confirmed detection occurred in a portion of a site with a storage vessel or closed vent system, inspection of all covers and closed vent systems that are connected to all storage vessels and closed vent systems that are within a 2-meter radius of the confirmed detection location (*i.e.*, you must inspect the whole system that is connected to the portion of the system, not just the portion of the system that falls within the radius of the detected event). Inspection must be conducted using either OGI or EPA Method 21, as well as visually to identify defects.

The follow-up monitoring that must be conducted for a confirmed detection during a periodic screening event using a technology with component-level spatial resolution includes:

- A monitoring survey of all the fugitive emissions components located within a 1-meter radius of the location of the confirmed detection using either OGI or EPA Method 21; and
- If the confirmed detection occurred in a portion of a site with a storage vessel or closed vent system, inspection of all covers and closed vent systems that are connected to all storage vessels and closed vent systems that are within a 0.5-meter radius of the confirmed detection location (*i.e.*, you must inspect the whole system that is connected to the portion of the system, not just the portion of the system that falls within the radius of the detected event). Inspection must be conducted, as well as visually to identify defects.

As proposed, the final rulemaking requires that the owner or operator follow the repair requirements and timelines in the December 2022 Supplemental Proposal for fugitive emissions components where emissions are detected from fugitive components, and the repair requirements for covers

¹⁸² See Memorandum in EPA-HQ-OAR-2021-0317.

and closed vent systems (CVS) if emissions are detected during the follow-up monitoring survey. We are also finalizing as proposed the requirement to conduct an investigative analysis when the source of a confirmed detection is determined to be a control device subject to the rule or an emission from or defect from a cover or closed vent system associated with an affected facility, although we have refined the requirements. These requirements include:

- Repair all fugitive emissions components, covers, and closed vent systems within 30 days after receiving the periodic screening data (except where delay of repair is allowed).
- Initiate an investigative analysis within 5 days if an emission or defect in a closed vent system or cover is determined to be the cause of the emissions.
- Initiate an investigative analysis within 24 hours of receiving the monitoring survey and inspection results if a failed control device is determined to be the cause of the emissions.
- Investigative analyses must be used to determine the underlying primary cause and other contributing causes to the emissions event. Owners and operators must determine the actions needed to bring the control device into compliance; how to prevent future failures of the control device from the same underlying cause(s); and updates are necessary to the engineering analysis for the cover or closed vent system to prevent future emissions from the cover and closed vent system.

2. Continuous Monitoring Screening

In this final rulemaking, the EPA is finalizing the continuing monitoring approach and associated work practice in the December 2022 Supplemental Proposed Rule with some changes to better account for background methane concentrations and to better incorporate additional types of measurement systems. The EPA has reexamined the proposed detection threshold for these systems and has adjusted that threshold in the final rule to better account for background methane concentrations.

The final rule includes defined requirements for operating continuous monitoring systems, including using advanced methane monitoring technology approved by the EPA for this purpose. This system must be set-up in a manner to generate a valid methane mass emission rate (or equivalent) once at least every twelve-hour block, have an operation downtime of less than 10 percent, and have checks in place to monitor the health of the system. We

have revised the proposed sensitivity requirements to allow systems with detection thresholds of 0.40 kg/hr of methane or lower and, are requiring systems to transmit data at least once every 24 hours. The final rule maintains the timeframe in the December 2022 Supplemental Proposal for when the owner or operator must initiate continuous monitoring using advanced methane detection technology (*i.e.*, within 120 days after startup of a fugitive emissions components affected facility and storage vessel affected facility at new, modified, and existing well sites, centralized production facilities, and/or compressor stations), as well as timeframes for initiating continuous monitoring if an owner or operator opts to switch to periodic screenings at a later time (*i.e.*, the owner or operator was originally conducting fugitive emissions surveys with OGI or EPA Method 21).

In the final rulemaking, we have revised the “action-levels” in the December 2022 Supplemental Proposal to account for the potential for background methane emission levels at many of these sites. An action-level is the time weighted average that triggers an investigative analysis to identify the cause(s) of the exceedance. For affected facilities located at wellhead only well sites, these “action-levels” are as follows:

- Rolling 90-day average of 1.2 kg/hr of methane over the site-specific baseline.
 - Rolling 7-day average of 15 kg/hr of methane over site-specific baseline.
- For affected facilities located at well sites with major production and processing equipment, small well sites, centralized production facilities, and compressor stations, the action levels are as follows:
- Rolling 90-day average of 1.6 kg/hr of methane over the site-specific baseline.
 - Rolling 7-day average of 21 kg/hr of methane over the site-specific baseline.

The final rule includes a new and defined set of criteria for the timeframe and site conditions under which to establish the site-specific baseline emissions since the December 2022 Supplemental Proposal, finalizes as proposed how to calculate emissions after the baseline has been established, and has refined the proposed actions the owner or operator must take when an “action-level” is exceeded. Prior to establishing the site-specific baseline, the owner or operator must perform inspections of the fugitive emissions components, any covers and closed vent systems, and control devices to ensure the site is leak free and in compliance

with the requirements in NSPS OOOOb and/or the applicable state plan implementing EG OOOOc. The owner or operator must then record the site-level emissions from the continuous monitoring system for 30 days and determine the mean emission rate, less any time periods when maintenance activities were conducted.

The final rule has changed the requirements in the December 2022 Supplemental Proposal for how to calculate the 7-day and 90-day rolling average to account for the site-specific baseline and has maintained the intent of required follow-up activities when exceedances of the action-level have occurred. We have also changed the nomenclature of the follow-up activities from “root cause analysis” to “investigative analysis” and from “corrective action” to “mass emission rate reduction plan” to eliminate confusion caused by the terminology we used in the December 2022 Supplemental Proposal. We have also more clearly specified the requirements for these activities. The requirements for an investigative analysis are as follows:

- The investigative analysis must be initiated within 5 days after an exceedance of an action-level to determine the underlying primary and contributing cause(s).
- When the 7-day action-level is exceeded, within 5 days after the exceedance the investigative analysis must be completed and initial steps must be taken to reduce the mass emission rate.
- When the 90-day action-level is exceeded, within 30 days after the exceedance the investigative analysis must be completed and initial steps must be taken to reduce the mass emission rate.

An owner or operator must develop a mass emission rate reduction plan when any of the following conditions have been met:

- For an exceedance of the 90-day action-level, 30-day average mass emission rate for the 30 days following the completion of the investigative analysis and initial steps to reduce the mass emission rate is not below the applicable 90-day action-level.
- For an exceedance of the 7-day action-level, the mass emission rate for the 24-hour period after the completion of the investigative analysis and initial steps to reduce the mass emission rate is not below the applicable 7-day action-level.
- The actions needed to reduce the emission rate below the applicable action-level will take more than 30 days to implement.

3. Alternative Test Method for Methane Detection Technology

In this final rule, the EPA has strengthened the alternative test method approval process for advanced methane detection technology used in periodic screening and continuous monitoring. The EPA has further clarified the Administrator authority in the approval process, the criteria for who may submit requests for approval, and the requirements for what information must be submitted by those entities seeking approval.

This final rule specifies a process for applying and obtaining the EPA's approval for the use of an advanced methane detection technology in lieu of the required monitoring methods in the rule by submitting the test method for the alternative technology. However, instead of relying on existing provisions for alternative test methods 40 CFR 60.8(b), we are in the final rule citing a new alternative test method provision in 40 CFR 60.5398b(d). This provision incorporates specific criteria for the review, evaluation, and potential use of advanced methane detection technology for use in periodic screening, continuous monitoring, and/or super-emitter detection.

This final rule maintains the procedures in the December 2022 Supplemental Proposal for submitting an alternative test method for methane detection technology request. These requests must be submitted to the Leader, Measurement Technology Group along with any supporting data to the methane detection portal at (www.epa.gov/emc/oil-and-gas-alternative-test-methods). Confidential Business Information (CBI) must not be submitted through this portal; detailed instructions for submitting information for which an entity submits a claim of CBI are provided in 40 CFR 60.5398b(d)(1). The Administrator will complete an initial completeness review of submissions within 90 days. An approval or disapproval will be issued in writing within 270 days after receiving a request. Submission approvals may be considered on a site-specific basis or more broadly applicable, depending on the technology and the information provided in the request.

The December 2022 Supplemental Proposal included limitations on which entities could submit an alternative test method request. The final rule retains these provisions while also providing improvements to allow for proprietary advanced methane measurement technology internally developed by owners and operators. Any entity that

meets the following specifications may submit an alternative test method request:

- The entity must be an individual or organization located in or that has representation in the United States.
- The entity must be an owner or operator of an affected facility under NSPS OOOOb or EG OOOOc.
- If the entity is the not the owner or operator of an affected facility, the entity must directly represent the provider of the candidate measurement system using advanced methane detection technology and the measurement system must have been applied to measurements and monitoring in the oil and gas sector (domestically or internationally).
- The candidate measurement system must have been sold, leased, or licensed, or offered for sale, lease, or license to the general public or developed by an owner or operator for internal use and/or use by external partners.

The final rule also expands upon the information you are required to provide to the Administrator when submitting a request to use an alternative test method for advanced methane detection technology. These expanded requirements represent the minimum amount of material required by the EPA to completely understand the functionality of candidate measurement technology systems, how these systems are applied to generate a methane mass emission rate (kg/hr) or equivalent emission rate, data management, detection threshold, and spatial resolution.

The final rule requires an entity to provide the Administrator contact information for the requester, the desired applicability of the technology, and a description of the candidate measurement technology system, including:

- A description of the scientific theory and appropriate references outlining the underlying technology;
- A description of the physical instrument;
- Type of measurement and desired application (*e.g.*, airborne, in-situ); and
- Potential limitations of the candidate measurement system, including application limitations.

The request must also include information on how the system converts results to a mass emission rate or equivalent. This information must include the following:

- Workflow and description covering all steps and processes from measurement technology signal output to final, validated mass emission rate (*i.e.*, kg/hr) or equivalent.

- Description of how any meteorological data are used, including how they are collected and/or sourced.
- Identification of any model(s) used, including how inputs are determined or derived.
- All calculations used, including the defined variables for any calculations.
- A-priori methods and datasets used.
- Explanation of any algorithms/machine learning procedures used in the data processing, if applicable.

The request must also include a description of how data collected and generated by the system are collected, maintained, and stored; how these data streams are processed and manipulated, including how the resultant data processing is documented; and a description of which data streams are provided to the end-user of the data and how that information is delivered or supplied.

The EPA has further refined the supporting information that must be used to verify detection thresholds and information on how the candidate measurement system must be applied to ensure the detection thresholds are maintained during monitoring events. We have also revised the detection threshold to an average aggregate detection threshold, which is defined as the average of all site-level detection thresholds from a single deployment (*e.g.*, a singular flight that surveys multiple well sites, centralized production facility, and/or compressor stations). The information provided in the request must include published reports produced by either the submitting entity or an outside entity evaluating the technology, standard operating procedures, alternative testing procedure(s) (preferably in the format described in Guideline Document 45),¹⁸³ and documents provided to end-users of the data.

The final rule includes a new requirement for entities to verify the spatial resolution of the candidate measurement system. The supporting information verifying the spatial resolution must be in the form of published report (*e.g.*, scientific papers) produced by either the submitting entity or an outside entity evaluating the submitted measurement technology that has been independently evaluated.

C. Super Emitter Program

This section presents a summary of the final standards for the Super Emitter Program. As described in section IV.C of the December 2022 Supplemental Proposal preamble (87 FR 74722,

¹⁸³ Available at <https://www.epa.gov/sites/default/files/2020-08/documents/gd-045.pdf>.

December 6, 2022), the EPA proposed the Super Emitter Program to ensure that this rulemaking comprehensively addresses the widespread problem of abnormally large emissions events known as super-emitters. The EPA is including the Super Emitter Program in this final rulemaking, previously proposed as the Super Emitter Response Program in the December 2022 Supplemental Proposal. The EPA has developed this program in response to recent studies, which indicate that a small portion of sources contribute almost 50 percent of the methane emissions in the oil and gas sector, and on a global scale, the largest of these emissions sources may represent as much as 12 percent of global methane emissions from oil and gas production. For purposes of this rule, a super-emitter event is one that has a quantified emission rate of 100 kg/hr of methane or greater.

As described here, this program is designed to provide a transparent, reliable, and efficient mechanism by which the EPA will provide owners and operators with timely notifications of super-emitter emissions data collected by the EPA-certified third parties using the EPA-approved remote sensing technologies (e.g., satellites). Where such an event is attributable to a source regulated under CAA section 111 (NSPS OOOO, OOOOa, or OOOOb, or a state or Federal plan implementing EG OOOOc), the responsible owner or operator will take action in response to such notifications in accordance with the applicable regulation.

The EPA anticipates that the NSPS and presumptive standards for existing sources that are included in this final rulemaking will reduce many sources of super-emitters. However, these events sometimes arise from planned maintenance, other routine operations, and are also frequently attributable to major malfunctions or improperly operating control devices. These events are unpredictable and can occur in between routine inspections and/or fugitive emissions monitoring surveys. Moreover, these events are sufficiently large to result in significant emissions of the harmful air pollutants regulated under this rule in a short span of time. By leveraging data collected by the EPA-approved third parties using the EPA-approved methods to identify such events and providing a mechanism for the EPA to promptly notify owners and operators of such events for appropriate follow-up action, the Super Emitter Program serves as both a complement and a backstop to the other requirements of this rulemaking.

As described in our response to comments, the EPA received several comments—including from owners and operators of regulated facilities—supporting the objectives of the Super Emitter Program and the importance of timely identifying and resolving super-emitter events. In this final rulemaking, the EPA has also made a number of changes to the Super Emitter Program in order to provide appropriate oversight by the EPA, address implementation concerns raised by commenters, and ensure that the program provides owners and operators with transparent, reliable, and timely information about super-emitter events.

As described in section IV.C of the December 2022 Supplemental Proposal preamble (87 FR 74746, December 6, 2022), the EPA proposed a Super Emitter Program as a backstop to address large methane super-emitters from this sector. This program is designed for the EPA to receive super-emitter emission data collected by the EPA-certified third parties using the EPA-approved remote sensing technologies (e.g., satellites) in a timely manner. In response to comments objecting to or otherwise expressing concerns with requiring owners and operators to respond directly to third-party notifications of super-emitter events, the EPA has revised the program in the final rulemaking such that it is the EPA, and not third parties, that will notify an identified owner or operator after reviewing third-party notifications of the presence of a super-emitter event at or near its oil and gas facility (e.g., a specific well site, centralized production facility, gas processing plant, or compressor station), requiring the owner or operator to investigate and report the results to the EPA. Also, in response to comments, the EPA emphasizes that certified third parties will only be authorized to use remote sensing technologies such as satellites or aerial surveys—i.e., this program does not authorize third parties to enter well sites or other oil and gas facilities, and it does not allow for the use of technologies such as OGI that would require close access to such facilities.

1. Statutory Authority

The Super Emitter Program finalized in this rule is based on the EPA's authority under CAA section 114(a) to require "any person who owns or operates any emission source" (except mobile sources)¹⁸⁴ to provide information necessary for purposes of

carrying out the CAA and its authority to regulate sources under CAA section 111. In the 2022 Supplemental Proposal, the EPA proposed two separate legal frameworks for the Super Emitter Program. 87 FR 74752. The final Super Emitter Program is based on the second legal framework. Under this framework, the EPA's authority to require sources (regardless of whether those sources are regulated under CAA section 111) to investigate potential sources of super-emitter events and report to EPA is CAA section 114. The EPA's authority to require regulated sources to repair or otherwise address the cause of the super-emitter event is CAA section 111. In particular, for sources regulated under CAA section 111, the Super Emitter Program will serve as: (1) an additional work practice standard under NSPS OOOOb (and presumptive standard under EG OOOOc) for fugitive emissions at well sites, centralized production facilities and compressor stations, and as (2) an additional compliance assurance measure for other NSPS OOOOb affected facilities, NSPS OOOO and OOOOa affected facilities, and designated facilities under EG OOOOc.

a. Authority To Require Investigation and Reporting for all Sources

The EPA's authority to require all sources, regardless of whether they are regulated under CAA section 111, to investigate potential super-emitter events and report back to the EPA stems from the EPA's broad authority under CAA section 114(a) to require, among other things, monitoring, reporting, and recordkeeping from owners and operators of stationary sources. CAA section 114(a)(1) gives the EPA broad authority to "require any person . . . to (A) establish and maintain such records; (B) make such reports; (C) install, use and maintain such monitoring equipment, and use such audit procedures, or methods; . . . and (G) provide such other information as the administrator may reasonably require" The EPA can impose such obligations on "any person who owns or operates any emission source," whether or not the emission source is regulated under the CAA, "[f]or the purpose of assisting in the development of any implementation plan under . . . section 7411(d) of this title, any standard of performance under section 7411 of this title," "determining whether any person is in violation of any such standard or any requirement of such plan," or "carrying out any provision of this chapter." CAA section 111(b) requires that the EPA review and, if appropriate, revise an NSPS at least every 8 years

¹⁸⁴ The EPA has similar information collection authority with respect to mobile sources under CAA section 208.

following its promulgation.¹⁸⁵ The information on super-emitter events from both regulated and unregulated oil and gas sources can help inform the EPA on the effectiveness of its current NSPS for this sector and potential focus in its future review. Therefore, based on the authority under CAA section 114(a), the Super Emitter Program requires owners and operators to investigate and report all sources, including non-NSPS/EG sources, that they suspect may have caused or contributed to the super-emitter event specified in the EPA notice that they have received, to ensure that a regulated source is not contributing to the event, as well as to provide useful information to the EPA in carrying out its review obligation under CAA section 111(b). The information on super-emitter events can also help owners and operators prevent or minimize losing a valuable product (natural gas).

b. Authority To Require Repair for Regulated Sources: Work Practice Standards for Fugitive Emissions

Pursuant to CAA section 111, the EPA has incorporated the Super Emitter Program, in particular the requirement to repair fugitive emissions components that are sources of super-emitter events, as a part of the BSER and therefore work practice standards for fugitive emissions components affected/designated facilities under NSPS OOOOb/EG OOOOc. As the first part of the fugitive emissions BSER and work practice standards, discussed in section X.A of this document, the EPA has established periodic monitoring and repair work practice standards as the BSER for these fugitive emissions components affected/designated facilities under NSPS OOOOb and EG OOOOc. Fugitive emissions may nevertheless occur from these components between the specified periodic monitoring. Emissions from certain fugitive emissions components can be significant (as one example, a stuck-open thief hatch) and can remain undetected until the next scheduled periodic monitoring. Accordingly, as the second part of the fugitive emissions BSER and work practice standard for affected/designated facilities under NSPS OOOOb and EG OOOOc, the EPA is requiring repair of fugitive emissions components that are the cause of super-

emitter events in between routine monitoring. While the EPA has determined that it is not cost effective to require more frequent periodic monitoring, where a super-emitter event (*i.e.*, 100 kg/hr) is caused by fugitive emissions components, repair to reduce such large emissions is clearly cost effective. To that end, the Super Emitter Program supplements the periodic monitoring and repair work practice standards in NSPS OOOOb (and presumptive standards in EG OOOOc) by requiring repair of fugitive emissions components affected/designated facilities under these subparts that the owner or operator has identified as the source of the super-emitter event through this program.¹⁸⁶ The owner or operator will conduct repair in accordance with the same repair requirements as those for fugitive emissions detected during the periodic monitoring, as specified in the applicable standard (*i.e.*, NSPS OOOOb or a state plan implementing EG OOOOc).

c. Authority To Require Monitoring and Reporting for Regulated Sources: Compliance Assurance for Other Regulated Sources

For regulated sources that are not fugitive emissions components affected/designated facilities under NSPS OOOOb/EG OOOOc, the presence of a super-emitter event suggests that the source may not be in compliance with the applicable requirements for that source contained in the EPA's regulations. The compliance assurance aspect of the Super Emitter Program is based on the EPA's regulations for individual emissions sources in the NSPS and EG promulgated pursuant to CAA section 111. NSPS OOOO/OOOOa/OOOOb and the model rule implementing EG OOOOc all include design and/or operational requirements¹⁸⁷ and monitoring,

recordkeeping, and reporting requirements¹⁸⁸ to assure that standards of performance¹⁸⁹ are being met. However, as explained above, super emitter events are unpredictable; they can occur between routine inspections and release significant emissions in a short span of time. To address this concern, the Super Emitter Program provides additional monitoring, reporting and recordkeeping for affected/designated facilities under NSPS OOOO/OOOOa/OOOOb and EG OOOOc based on the EPA's authority under CAA section 114(a) to impose such requirements for purposes of determining whether or not standards under these subparts are being met. Where a super-emitter event originates from one of these affected/designated facilities or associated equipment regulated under NSPS OOOO, OOOOa, OOOOb, or a state or Federal plan implementing EG OOOOc, the Super Emitter Program serves as an additional source of monitoring data to inform and alert owners and operators to check and make sure that the source and associated control device and equipment are operating as required under the applicable NSPS or State or Federal plan implementing EG OOOOc. For example, a super-emitter event may be caused by an open thief hatch on a storage vessel subject to NSPS OOOOa, which is not permitted except for very limited circumstances as defined in the rule. In that event, the Super Emitter Program serves to alert an owner or operator of the need to close the thief hatch pursuant to the requirements of NSPS OOOOa, but the Super Emitter Program does not itself impose a requirement to close the thief hatch. Since there are already requirements in place to bring emissions down to or below the applicable NSPS standards (and will be in state or Federal plans implementing EG OOOOc), the Super Emitter Program does not itself independently require specific actions

assurance requirements include 40 CFR 60.5411/60.5411a (cover and closed vent system requirements) and 60.5412/60.5412a (control device requirements) in NSPS OOOO/OOOOa.

¹⁸⁸ The EPA has long relied on CAA section 114 to establish monitoring, recordkeeping, and reporting requirements to implement and enforce the emissions standards promulgated under CAA section 111 (*see, e.g.*, 36 FR 24876 (December 23, 1971) (NSPS for the initial five listed source categories, citing both CAA sections 111 and 114 as the statutory authorities). That was the case with the 2012 NSPS OOOO and 2016 NSPS OOOOa, and the EPA has similarly included such measures in the present rule in NSPS OOOOb and in the model rule for EG OOOOc.

¹⁸⁹ These do not include fugitive emissions components affected/designated facilities under NSPS OOOOb and EG OOOOc, which the EPA has separately addressed, as discussed above.

¹⁸⁵ As explained earlier in section IV.A of this preamble, CAA section 111(b)(1)(B) provides the EPA discretion to determine the pollutants and sources to be regulated. In addition, concurrent with the 8-year review (and though not a mandatory part of the 8-year review), the EPA may examine whether to add standards for pollutants or emission sources not currently regulated for that source category.

¹⁸⁶ As explained in the 2022 Supplemental Proposal (87 FR 74753), despite our incorporation of this additional repair requirement under the Super Emitter Program into the work practice standards for the fugitive emissions components at well sites, centralized production facilities and compressor stations, this repair requirement is nevertheless severable from the periodic monitoring and repair work practices that we have separately analyzed and established as the BSER for fugitive emissions at each of these facilities. In addition, the additional repair requirement of the Super Emitter Program is severable from the CAA section 114(a)(1) monitoring and reporting aspect of the Program.

¹⁸⁷ The EPA establishes "standards of performance" pursuant to CAA section 111. CAA section 302(l) defines a "standard of performance" to include not only standards limiting the quantity, rate, or concentration of emissions, but also requirements "relating to the operation or maintenance of a source to assure continuous emission reduction." Examples of such compliance

to address emissions from super-emitter events attributed to NSPS or EG sources; it merely puts owners and operators on notice that action may be required to bring a source back into compliance with the applicable emission standards. To clarify this point, the final rule includes amendments to NSPS OOOO and OOOOa to incorporate relevant compliance assurance provisions of the Super Emitter Program, specifically the requirement to investigate and report whether the super-emitter event was caused by a NSPS OOOO or OOOOa affected facility or associated equipment.

2. Major Elements

The following describes the major elements in the Super Emitter Program that serve to assure the reliability of the super-emitter data that the EPA receives under this program. These elements ensure that the data the EPA receives is meaningful and lead to expeditious and effective mitigation of super-emitter events by owners and operators, whether required or voluntarily.

a. Qualifications for Third-Party Notifiers

A third party can be any independent entity, meaning that the third party does not own or operate the site where a super-emitter is detected. In this final rulemaking, the EPA is maintaining the requirements for the qualification of the third-party notifiers in the December 2022 Supplemental Proposal, including the requirement that notifiers use remote sensing technologies. These technologies and their method for operation must be approved under the advanced methane detection technology program in 40 CFR 60.5398b(d). Third parties are limited to using remote sensing technologies such as satellites or aerial surveys and would not be authorized by this program to enter a site.

b. Third-Party Notifier Certification

In this final rulemaking, the EPA establishes a framework by which we will certify third-party notifiers from whom the EPA would accept data from super-emitter events under the Super Emitter Program. The final rulemaking includes provisions governing how the third-party must submit a request to be certified, requirements that a third-party must meet to be certified and/or recertified, obligations for notifiers to maintain records of surveys performed to maintain certification, and procedures for revoking a notifiers certification.

A third-party notifier certification request must be submitted to the Leader,

Measurement Technology Group, 109 T.W. Alexander Drive, P.O. Box 12055, Research Triangle Park, NC 27711. If your request contains CBI, you must transmit these data electronically using email attachments, File Transfer Protocol, or other online file sharing services.¹⁹⁰ This request must include general identification for the entity submitting the request, including the mailing address, physical address, and contact information for the principal officer and certifying official(s). This request must also include the following information:

- Description of the advanced methane detection technologies that the third party intends to use, including reference to any alternative test method approval under 40 CFR 60.5398b(d), and any agreements with the technology providers.
- Curriculum vitae of the certifying official(s) detailing training for evaluating results of the chosen advanced methane detection technology.
- The entity's standard operating procedure(s) detailing the procedures and processes used by the entity for data review, including the accuracy of emissions data and locality data provided by the technology provider, how the entity will identify the owner or operator of a site, and procedures for handling potentially erroneous data.
- Description of the system for maintaining essential records.
- A Quality Management Plan consistent with the EPA's Quality Management Plan Standard (Directive No: CIO 2015-S-01.0, January 17, 2023).

An entity that has received third-party approval must maintain the following records in order to retain its certification status:

- Records for all surveys conducted by or sponsored by the certified third-party notifier that are the basis for a third-party super-emitter identification submitted to the EPA.
- Records for any notifications provided to the EPA and any additional data collected supporting the notification not required by the EPA to be reported.
- Records or identification of databases used to identify owner or operators of sites where super-emitter events reported to the EPA occurred.

The Administrator will assess the completeness, reasonableness, and accuracy of the third party's request based on the updated certification criteria in the final rule. Once certified, the third-party notifier will receive a

unique notifier ID which will be posted at www.epa.gov/emc-third-party-certifications. If there is any material change to the information included in the third party's initial certification request, e.g., a change to the technology that the third party intends to use or a change to the certifying official(s), the final rule requires the third party to submit a revised request and be recertified before implementing those changes.

As proposed, the EPA is finalizing provisions providing for the revocation of a third party's certification under certain conditions. In response to comments, the EPA has expanded in the final rule the circumstances for removing a third-party certification, which are as follows:

- Submitting super-emitter notifications after making material changes to the third party's procedures for identifying super-emitters without seeking recertification.
- If the Administrator finds that the certified third-party notifier has persistently submitted data with significant errors.
- Having engaged in illegal activity during the assessment of a super-emitter event (e.g., trespassing).
- Upon determination by the Administrator, following petition from the owner or operator, that the owner or operator has received from the EPA more than three notices with meaningful and/or demonstrable errors of a super-emitter event at the same oil and natural gas facility (e.g., a well site, centralized production facility, natural gas processing plant, or compressor station), that were submitted to the EPA by the same third party, and the owner or operator demonstrates that the claimed super-emitter event did not occur. The failure of the owner or operator to find the source of the super-emitter emissions event upon subsequent inspection would not be proof, by itself, of demonstrable error on the part of the third-party notifier.

c. Notification of Super-Emitter Events

In the final rules, the EPA has amended the super-emitter notification process in the December 2022 Supplemental Proposal to now include a step whereby the EPA will receive and review the super-emitter data from certified third-party notifiers before triggering any obligation on the part of the owner or operator. The final rules require the third-party notifier to submit notifications to the EPA within 15 calendar days after detection of a super-emitter event to ensure timely notice and includes standards for the content of the notification to aid in the EPA's

¹⁹⁰ Please email oaqpscbi@epa.gov to request a file transfer link.

review of the data. Third-party notifications must be submitted into the Super Emitter Program Portal at <https://www.epa.gov/super-emitter> and must include the following:

- Unique Third-Party Notifier ID.
- Date of detection of the super-emitter event.
- Location of super-emitter event in latitude and longitude coordinates.
- Owner(s) or operator(s) of an oil and natural gas facility of any individual well site, centralized production facility, or compressor station within 50 meters of the latitude and longitude coordinates of the super-emitter event, if available, and the method used by the third party to identify the owner or operator.
- Identification of the detection technology and reference to the approval of the technology.
- Documentation (e.g., imagery) depicting the detected super-emitter event and the site from which the super-emitter event was detected.
- Quantified emission rate of the super-emitter event in kg/hr.
- Attestation statement that the information submitted by the third-party notifier is true and accurate to the best of the notifier's knowledge.

Upon receiving a third-party notification of super-emitter data through the Super Emitter Program Portal, the EPA will evaluate the notifications for completeness and accuracy to a reasonable degree of certainty. When the EPA determines that a notification has met these conditions, the EPA shall assign the notification a unique notification identification number, provide the notification to the owner/operator, and post the notification, except for the owner/operator attribution, at www.epa.gov/super-emitter. This approach responds to comments asking that notice of super-emitter events be provided as quickly as possible, both to the public and the identified owner/operator, but also that the owner/operator have an opportunity to respond before the super-emitter event is publicly attributed to a particular owner/operator. The EPA shall post owner/operator attributions that have been confirmed through the responses received; where response submittal deadlines have passed but no responses have been received, the EPA intends to post owner/operator attributions that the EPA reasonably believes to be accurate.

d. Identification of a Super-Emitter Event

In the final rules, the owner or operator must initiate an investigation

within 5 days after receiving an EPA notification of a super-emitter event and report the results to the EPA within 15 days after receiving such notification. If an owner or operator determines that they do not own or operate a well site, centralized production facility, or compressor station within 50 meters from the latitude and longitude provided in the notification, the owner or operator must report that to the EPA and the investigation is then complete. Otherwise, the owner or operator must investigate to determine the source of the super-emitter event.

As explained earlier in this section X.C, a super-emitter event may have been emitted from one or more of the following: (1) an affected facility or associated equipment (e.g., a control device or CVS) subject to regulation under NSPS OOOO, OOOOa, or OOOOb (“NSPS sources”); (2) a designated facility or associated equipment subject to a state or Federal Plan promulgated pursuant to EG OOOOc (“EG sources”); or (3) an unregulated source (i.e., one that is not (1) or (2) above). Therefore, the investigation is not limited to NSPS or EG sources but also includes other sources that the owner or operator may suspect could be the source of the super-emitter event.

The owner or operator must investigate and report to the EPA the results of the investigation within 15 days after receiving a notification from the EPA. The owner and operator must also maintain a record of these investigations. To provide confidence in the reported information, the final rule has updated the list of investigations that the EPA believes will most likely reveal the source of the super-emitter event. Because the relevant investigations for identifying the source(s) of the super-emitter event may vary depending on what the third-party data reveals, the final rules defer to the owner and operator in deciding the appropriate investigation(s). However, where there are affected or designated facilities or associated equipment onsite, the owner and operator may conclude that they are unable to identify the source of the super-emitter event only after having conducted the applicable investigation listed in the respective final rule for each affected or designated facility and associated equipment.

The list of potential actions to identify the potential cause of super-emitter events may include but are not limited to the following:

- Review any maintenance activities (e.g., liquids unloading) or process activities starting from the date of

detection of the super-emitter event as identified in the notification.

- Review all monitoring data from control devices (e.g., flares) over the same time period.
- Review any fugitive emissions survey performed under a fugitive emissions monitoring plan over the same time period.
- Review data from any continuous alternative technology systems over the same time period.
- Screen the entire well site, centralized production facility, or compressor station with OGI, EPA Method 21, or an alternative test method(s).

e. Super-Emitter Event Report

As was proposed, the final rules require that the owner or operator submit a report to the EPA within 15 days after receiving a Super-Emitter Event notification through the Super Emitter Program Portal, including an attestation that the report is complete and accurate. The report must include the following information:

- Notification Report ID
- Confirmation that you are the owner or operator of the oil and gas facility within the immediate area (i.e., 50 meters) of the latitude and longitude provided in the notification. If you do not own or operate an oil and gas facility within 50 meters of the latitude and longitude provided in the notification, you are not required to provide the additional information described below.
- General identification for the facility, including physical address and applicable ID (e.g., EPA ID Number, American Petroleum Institute (API) Well ID) and the responsible official.
- Whether there are affected facilities or associated equipment subject to NSPS OOOO, OOOOa or OOOOb or designated facilities or associated equipment subject to a state or Federal plan pursuant EG OOOOc.
- Attestation that investigations were conducted to verify the presence or the absence of a super-emitter event.
- If you were unable to identify the source of the super-emitter and if there are NSPS OOOO, OOOOa or OOOOb affected facilities or associated equipment, or designated facilities or associated equipment subject to a state or Federal plan pursuant EG OOOOc, onsite, confirmation that you have conducted all investigations listed in the Super Emitter Program (as specified above in section X.C.2.d) that are applicable to such affected or designated facilities and associated equipment.

- If a super-emitter source is identified, what the source is and whether it is (i) an affected facility or associated equipment subject to NSPS OOOO, OOOOa, or OOOOb or (ii) a designated facility or associated equipment subject to a state or Federal plan under EG OOOOc.

- If a super-emitter event is found, the date and time the super-emitter event ended.

Upon receiving this information from the owner or operator, the EPA will update the notification report with the information provided by the owner or operator and will make the updated report publicly available at www.epa.gov/super-emitter. If a super-emitter event emitted from an NSPS OOOO, OOOOa or OOOOb affected facility or associated equipment or a designated facility or associated equipment subject to a state or Federal plan pursuant EG OOOOc, or associated equipment, is ongoing, you are also required to report to the Super Emitter Program Portal the following information:

- A short narrative on how you intend to end the super-emitter event, including the targeted date for completion.

- Within 5 days after the super-emitter event has ended, the date and time the super-emitter event ended.

As discussed earlier in this section X.C, CAA 114(a) gives the EPA broad authority to require that owners and operators investigate and report all sources that they suspect may have caused or contributed to the super-emitter event specified in the EPA notice that they have received under the Super Emitter Program. CAA 114(a) does not require regulatory text for the EPA to exercise its information gathering authority under CAA 114(a), and the EPA believes that adequate notice is provided in this **Federal Register** document, which clearly sets forth the required investigations and reporting requirements under the Super Emitter Program and their applicability to all oil and gas emission sources, whether or not they are subject to any applicable CAA section 111 standard. Nevertheless, to facilitate the implementation of the Super Emitter Program, the EPA has codified provisions of the Super Emitter Program into the regulatory text of the new NSPS OOOOb and, as appropriate, in the model rule implementing EG OOOOc and amendments to NSPS OOOO and OOOOa. Specifically, NSPS OOOOb provides the major framework for the Super Emitter Program, including criteria for certifying third-party notifiers, criteria for third-party

notifications to the EPA, and provisions governing the EPA's notification of identified owners and operators.¹⁹¹ In addition, NSPS OOOOb includes regulatory text governing the investigation and reporting as they relate to NSPS OOOOb affected facilities and associated equipment. Similarly, the EPA has amended NSPS OOOO and OOOOa to include super-emitter event investigation and reporting requirements as they relate to affected facilities and associated equipment under those NSPS. Such provisions are also included in the model rule implementing EG OOOOc. In addition, both NSPS OOOOb and the model rule implementing EG OOOOc includes a requirement to repair fugitive component(s) that owners and operators have identified as the source of super-emitter event specified in the EPA notice; as explained earlier in this section X.C, the standards for fugitive emissions components affected facilities under NSPS OOOOb (and presumptive standards under EG OOOOc) include a requirement to repair fugitive component(s) that owners and operators have identified as the source of super emitter-event specified in the EPA notice.

Further, pursuant to the Paperwork Reduction Act (PRA), the EPA estimated the reporting burden under the Super Emitter Program when it issued the December 2022 Supplemental Proposal. The total burden presented in section XVII.B for NSPS OOOOb of this final preamble includes the reporting burden for the entire Super Emitter Program, including reporting pertaining to affected facilities under NSPS OOOO and NSPS OOOOa and non-NSPS sources. The estimated reporting burden for the final Super Emitter Program has not changed since the December 2022 Supplemental Proposal and includes the estimated burden of required activities under the Super Emitter Program such as third-party certifications and notifications to the EPA and reporting requirements for identified owners and operators. Both the supplemental proposal and this final rulemaking have been reviewed by the Office of Management and Budget (OMB) through the interagency review process. The EPA envisions that for simplicity, completeness, and transparency, owners and operators would prefer one comprehensive Super Emitter Program over the possibility of having to respond

¹⁹¹ Unlike the EPA, the Super Emitter Program imposes no obligations on States; their obligation under this final rule is to promulgate a state plan implementing EG OOOOc, as required under CAA 111(d) and EPA's implementing regulation at 40 CFR part 60, subpart Ba.

to two EPA notices on a super-emitter event.

D. Process Controllers

Process controllers are automated instruments used for maintaining a process condition, such as liquid level, pressure, pressure difference, or temperature. In the oil and gas industry, many process controllers are powered by pressurized natural gas and emit natural gas to the atmosphere. However, process controllers may also be powered by electricity or compressed air, and these types of controllers do not use or emit natural gas. Natural gas-driven process controllers are a significant source of methane emissions. For instance, in the 2019 GHGRP, methane emissions from process controllers made up 65 percent of the total methane emissions from petroleum system onshore production and 28 percent of the total methane emissions from natural gas systems onshore production.

In the December 2022 Supplemental Proposal, the EPA proposed a “zero emissions” VOC and methane standard in NSPS OOOOb and a “zero emissions” methane presumptive standard in EG OOOOc. This standard can be achieved by using a process controller that is not powered by natural gas, by capturing the emissions from the natural gas-driven controllers and routing them to a process, or by using self-contained controllers. The proposed rules included an exemption from the zero-emissions requirement for process controllers in Alaska at locations where access to electrical power from the power grid is not available. The proposed requirements for these sources in Alaska were to use lower emitting natural gas-driven process controllers and to perform inspections to ensure that they are operating properly. While there are changes to some compliance aspects in the final rules, such as a further-out compliance date than proposed with an interim standard for the NSPS, the zero-emissions standard in NSPS OOOOb and presumptive standard in EG OOOOc (with the Alaska exemption) are being finalized as proposed.

1. NSPS OOOOb

a. Affected Facility

The standards apply to the collection of new, modified, and reconstructed natural gas-driven process controllers at a site (*i.e.*, a well site, centralized production facility, onshore natural gas processing plant, or compressor station). Process controllers that are emergency shutdown devices (ESD) or that are not

natural gas-driven are not included in the affected facility.

b. Final Standards

The standards that apply differ depending on the location of the site and whether access to electrical power is available at the site, which are sites that have commercial line power onsite. For any site outside of Alaska, the standard for all process controllers is zero emissions of VOC and GHG (in the form of methane). Zero emissions of VOC and GHG may be achieved by using process controllers that are not driven by natural gas (and thus not affected facilities), by routing natural gas-driven process controller vapors

through a closed vent system to a process, by using self-contained natural gas-driven process controllers, or by another means that achieves the numerical standard of zero emissions of GHG (in the form of methane) and VOC. For sites in Alaska with access to electrical power the standard for all process controllers at the site is also zero emissions of VOC and GHG. For sites in Alaska without access to electrical power, owners/operators must use natural gas-driven process controllers with low natural gas emission rates. These process controllers include continuous bleed controllers with an emissions rate (or

bleed rate) of less than or equal to 6 standard cubic feet per hour (scfh) and intermittent vent controllers, which are process controllers that only emit natural gas when they actuate, rather than emitting continuously. Intermittent vent controllers are subject to monitoring requirements explained below. Further, as an optional alternative, sites in Alaska without access to electrical power may route emissions from natural gas-driven process controllers to a control device achieving a 95 percent emissions reduction. Table 12 summarizes the emissions standards for process controllers.

TABLE 12—SUMMARY OF PROCESS CONTROLLER EMISSIONS STANDARDS

Location of site	Site has access to electrical power	Emissions standard	Emissions standard compliance method
Outside Alaska.	Yes or No	Zero GHG and VOC emissions.	Use process controllers not driven by natural gas Or Route natural gas-driven process controller emissions through a closed vent system to a process Or Use self-contained natural gas-driven process controllers Or Other means to achieve zero-emissions standard.
In Alaska	Yes	Zero GHG and VOC emissions.	Use process controllers not driven by natural gas Or Route natural gas-driven process controller emissions through a closed vent system to a process Or Use self-contained natural gas-driven process controllers Or Other means to achieve zero-emissions standard.
In Alaska	No	95 percent emissions control Or Emissions achieved by use of low-emitting controllers.	Route natural gas-driven process controller emissions through a closed vent system to a control device that reduces emissions by ≥95 percent Or Use low-bleed or intermittent vent natural gas-driven process controllers with monitoring for intermittent process controllers.

Based on comments expressing concerns about new sources' ability to obtain the equipment necessary to demonstrate compliance with the final standard of zero emissions immediately upon the effective date of the final rule, the EPA is finalizing a NSPS compliance deadline for process controllers that allows for up to 1 year from the effective date of the final rule. This means that new sources will have up to 1 year to come into full compliance with the final standard of

zero emissions. Until that final date of compliance, owners and operators must demonstrate compliance with an interim standard which mirrors the requirements for sites in Alaska that do not have access to electrical power. This topic is explained in detail in section XI.D.4 below.

c. Monitoring Requirements

Monitoring is required for most natural gas-driven process controllers. For self-contained process controllers,

initial and periodic monitoring is required to demonstrate that there are no identifiable emissions from the process controller. For intermittent process controllers (allowed at sites in Alaska without access to electrical power), initial and periodic monitoring is required to demonstrate that there are no identifiable emissions from the process controller when the process controller is idle. For process controllers that have emissions routed through a closed vent system to a process or to a

control device, initial and periodic monitoring is required to demonstrate that there are no identifiable emissions from the closed vent system. In addition to the closed vent system monitoring requirements, process controllers that have emissions routed through a closed vent system to a control device (allowed at sites in Alaska without access to

electrical power) must perform the monitoring specified in 40 CFR 60.5417b for the particular type of control device that is used. As further discussed in sections X.H and XI.H of this document, each control device must have a continuous parameter system installed and a continuous recording device for the monitoring results.

Enclosed combustion devices and flares also must have either periodic visible emissions inspections or use a surveillance camera system to monitor for visible emissions. A summary of the required monitoring for natural gas-driven process controllers is shown in table 13.

TABLE 13—SUMMARY OF PROCESS CONTROLLER INSPECTION AND MONITORING REQUIREMENTS

Equipment type	Monitoring requirement	Monitoring frequency
Natural gas-driven self-contained controllers	Use OGI or EPA Method 21 to demonstrate no identifiable emissions from the process controller.	Initially and quarterly.
Natural gas-driven intermittent vent controllers (Alaska-only sites without electrical power).	Use OGI or EPA Method 21 to demonstrate no identifiable emissions occur during idle periods.	Initially and quarterly.
Closed vent system on a natural gas-driven process controller.	Use OGI or EPA Method 21 to demonstrate no identifiable emissions from the closed vent system.	Initially and quarterly..
Control device for a natural gas-driven process controller (Alaska-only sites without electrical power).	AVO monitoring	Initially and bi-monthly.
	Inspection for defects that could result in air emissions	Annually.
	Parameter monitoring	Continuously
	Visible emissions inspections for enclosed combustion devices and flares.	Monthly.
	Or	
	Surveillance camera monitoring	Continuously.

d. Recordkeeping and Reporting Requirements

Owners or operators of a process controller affected facility are required to submit information about the affected process controller facility in annual reports. The information required for the first annual report includes an identification of each natural gas-driven controller included in the process controller affected facility and an identification of the emissions standards compliance method that will be used for the affected facility. The initial annual report must also include a demonstration that a natural gas-driven process controller with a bleed rate greater than 6 scfh is required if such a process controller is used in Alaska at a site without access to electricity (the standard allows a process controller with a bleed rate greater than 6 scfh in certain circumstances), and also a certification that the closed vent system is adequately designed if a closed vent system is used for a process controller affected facility. After the initial annual report, this information about the affected facility is only required to be submitted in the annual report if there are changes to the previously submitted information. Each annual report must include the dates and results of inspections conducted for self-contained and intermittent vent natural gas-driven process controllers, inspections of closed vent systems (for sites routing emissions to a process or sites in Alaska routing emissions to a control device), monitoring and

inspections of control devices (for sites in Alaska using a control device to reduce emissions by 95 percent), and information for any deviations from the process controller emissions standards that occurred during the reporting period.

Owners and operators are also required to keep records of the information submitted in the annual reports regarding the process controller affected facility, and if applicable, the records required for monitoring and inspections of closed vent systems, control devices, self-contained process controllers, and intermittent vent process controllers. Records of each deviation must also be kept.

2. EG 0000c

a. Designated Facility

The final EG define designated facilities for purposes of process controllers as the collection of existing natural gas-driven process controllers at a well site, centralized production facility, onshore natural gas processing plant, or compressor station. Process controllers that are emergency safety devices (ESD) or that are not natural gas-driven are not included in the designated facility.

b. Final Presumptive Standards

The presumptive methane standards for existing sources under EG 0000c are the same as the final methane standards for new sources under NSPS 0000b.

c. Monitoring Requirements

The monitoring requirements in EG 0000c are the same as those for NSPS 0000b.

d. Recordkeeping and Reporting Requirements

The recordkeeping and reporting requirements in EG 0000c are the same as those for NSPS 0000b.

E. Pumps

In the oil and natural gas industry, pumps are used for many purposes, including chemical injection, hot glycol circulation for heat tracing/freeze protection, and glycol circulation in dehydrators. These pumps are generally either piston pumps or diaphragm pumps that can be powered by compressed air, compressed natural gas, or electricity. Of these pumps, those that are pneumatic units driven by natural gas emit methane and VOC to the atmosphere as part of their normal operation. In many situations across all segments of the oil and gas industry, natural gas-driven pneumatic pumps are used where electricity is not readily available.

In the December 2022 Supplemental Proposal, the proposed standard in NSPS 0000b and presumptive standard in EG 0000c was zero emissions of methane and VOC. The proposed standards may be achieved by the use of pumps not powered by natural gas. In that situation, the pump would not be an affected or designated facility because it would not be powered by natural gas. For sites in the

production or transmission and storage segment of the industry without access to electricity from the power grid, the proposed standards in the December 2022 Supplemental Proposal included a complex hierarchical structure that allowed the use of natural gas-driven pumps in certain situations based on the technical feasibility of pump control measures and the existence of situations that would allow the emissions to be routed to a process or to a control device already on a site. In the final rule, the complex hierarchical structure has been removed, and final NSPS OOOOb and EG OOOOc (presumptive standard) specify zero emissions for all pumps except those at sites without access to electricity with fewer than three natural gas-driven diaphragm pumps. For those sites, the final standards in NSPS OOOOb and presumptive standards in EG OOOOc are based on whether an existing situation exists that allows the emissions to be routed to a process or to a control device already on site.

1. NSPS OOOOb

a. Affected Facility

The pump standards apply to the collection of new, modified, and reconstructed natural gas-driven pumps at a well site, centralized production facility, onshore natural gas processing plant, or compressor station. Pumps that are in operation less than 90 days per calendar year or that are not natural gas-driven are not included in the affected facility.

b. Final Standards

The standards that apply differ depending on the number of natural gas-driven diaphragm pumps at the site (*i.e.*, well site, centralized production facility, onshore natural gas processing plant, or compressor station) and whether the site has access to electrical grid power. For any site with access to electrical power and for sites without access to electrical power that have three or more natural gas-driven diaphragm pumps, the standard for all

pumps in the affected facility is zero emissions of VOC and GHG (in the form of methane). Zero emissions of VOC and GHG may be achieved by either using pumps that are not driven by natural gas (and are therefore not affected facilities), by routing natural gas-driven pump vapors through a closed vent system to a process, or by other means that achieves the standard of zero emissions. For sites without access to electrical power that have fewer than three diaphragm pumps (two or one), the standards require that GHG and VOC emissions from all natural gas-driven pumps in the affected facility be routed to a process if a vapor recovery unit (VRU) is onsite. If a VRU is not onsite, emissions must be reduced by 95 percent if a control device with at least this emissions reduction capability is already available onsite, or be reduced by less than 95 percent if a control device is onsite but is not capable of reducing GHG and VOC emissions by 95 percent or more. Table 14 summarizes the emissions standards for pumps.

TABLE 14—SUMMARY OF PUMP EMISSIONS STANDARDS

Facility site electrical access to power?	Number of natural gas-driven diaphragm pumps at pump affected facility site	Standard	Compliance method
Yes	Any	Zero GHG and VOC emissions	Use pumps not driven by natural gas Or Route pump emissions through a closed vent system to a process Or Other means to achieve zero-emissions standard.
No	Has ≥3 diaphragm pumps	Zero GHG and VOC emissions	Use pumps not driven by natural gas Or Route pump emissions through a closed vent system to a process Or Other means to achieve zero-emissions standard.
No	Has <3 diaphragm pumps	Control emissions if VRU or control device is already present at site and can accept emissions from pumps.	Route pump emissions through a closed vent system to a process if a VRU is onsite; if no VRU onsite, route emissions to a control device that reduces emissions by ≥95 percent; if no control device capable of reducing emission by ≥95 percent is present then still route to control device if present.

Just as with process controllers, and based on comments expressing concerns about new sources' ability to obtain the equipment necessary to demonstrate compliance with the final standard of zero emissions immediately upon the effective date of the final rule, the EPA is finalizing a NSPS compliance deadline for pumps that allows for up to 1 year from the effective date of the final rule. This means that new sources will have up to 1 year to come into full compliance with the final standard of zero emissions. Until that final date of compliance, owners/operators must

demonstrate compliance with an interim standard which mirrors the requirements for pumps at sites without access to grid electricity that have fewer than three diaphragm pumps found at 40 CFR 60.5393b(b). This topic is explained in detail in section XI.E.2 below.

c. Monitoring Requirements

Monitoring is required for pump affected facilities that have emissions routed to a process or control device. For these affected facilities, initial and periodic monitoring is required to demonstrate that there are no

identifiable emissions from the closed vent system. In addition to the closed vent system monitoring requirements, pumps that have emissions routed through a closed vent system to a control device reducing emissions by 95 percent or more must perform the monitoring specified in 40 CFR 60.5417b for the particular type of control device that is used. As further discussed in sections X.H and XI.H of this document, each control device must have a continuous parameter system installed and a continuous recording device for the monitoring results.

Enclosed combustion devices and flares also must have either periodic visible emissions inspections or use a

surveillance camera system to monitor for visible emissions. A summary of the

required monitoring for pump affected facilities is shown in table 15.

TABLE 15—SUMMARY OF PUMP INSPECTION AND MONITORING REQUIREMENTS

Equipment type	Monitoring requirement	Monitoring frequency
Closed vent system on a natural gas-driven pump.	Use OGI or EPA Method 21 to demonstrate no identifiable emissions from the closed vent system.	Initially and quarterly.
	AVO monitoring Inspection for defects that could result in air emissions.	Initially and bi-monthly. Annually.
Control device achieving 95 percent emissions reduction for a natural gas-driven pump.	Control device parameter monitoring.	Continuously.
	Visible emissions inspections for enclosed combustion devices and flares. Or Surveillance camera monitoring	Monthly. Continuously.

d. Recordkeeping and Reporting Requirements

Owners or operators of a pump affected facility are required to submit information about the affected pump facility in annual reports after becoming subject to NSPS OOOOb. The information required for the first annual report includes an identification of each natural gas-driven pump included in the pump affected facility and an identification of the emissions standards compliance method that will be used for the affected facility. The initial annual report must also include a certification that the closed vent system is adequately designed if a closed vent system is used for the pump affected facility. If complying by using a control device that achieves less than 95 percent emissions control or if no control device will be used, owners or operators must include a certification that no control device is on site that is capable of achieving a 95 percent emissions reduction or a certification that no control device is present at the site. After the initial annual report, this information about the affected facility is only required to be submitted in the annual report if there are changes to the previously submitted information. Each annual report must include the dates and results of inspections conducted of closed vent systems, monitoring and inspections of control devices that reduce emissions by 95 percent or more, and information for any deviations from the pump emissions standards that occurred during the reporting period.

Owners and operators are also required to keep records of the information submitted in the annual reports regarding the pump affected facility, and if applicable, the records required for monitoring and inspections of closed vent systems and control

devices. Records of each deviation must also be kept.

2. EG OOOOc

a. Designated Facility

These final EG define designated facilities as the collection of natural gas-driven pumps at a well site, centralized production facility, onshore natural gas processing plant, or compressor station. Pumps that are in operation less than 90 days per calendar year or that are not natural gas-driven are not included in the designated facility.

b. Final Presumptive Standards

The presumptive methane standards for existing sources under EG OOOOc are the same as the methane standards for new sources under NSPS OOOOb.

c. Monitoring Requirements

The monitoring requirements in EG OOOOc are the same as those for NSPS OOOOb.

d. Recordkeeping and Reporting Requirements

The recordkeeping and reporting requirements in EG OOOOc are the same as those for NSPS OOOOb.

F. Wells and Associated Operations

A well is a hole drilled for the purpose of producing oil or natural gas. Many of the sources covered by NSPS OOOOb and addressed by EG OOOOc are associated with processes and equipment that is used to handle, store, move, and process the oil and natural gas downstream of the well. There are three sources, however, that are more directly related to the well itself. These are well completions, liquids unloading from gas wells, and associated gas from oil wells. In the November 2021 Proposal, the EPA proposed separate NSPS OOOOb affected facility

definitions for each of these three sources. The result of including all three definitions would have been that a single well could have three different affected facilities for three different emissions sources. In the December 2022 Supplemental Proposal, to eliminate the potential confusion from this complex regulatory structure, the EPA proposed to change its approach as part of the supplemental proposal. Rather than three separate well affected facilities, the EPA proposed a definition of well affected facility, which is defined as a single well. Separate standards were proposed for well completions, liquids unloading from gas wells, and associated gas from oil wells. This structure is retained in the final rule.

For existing sources, there will never be well completions, as that activity is only performed for newly constructed or reconstructed/modified wells. Therefore, the proposed EG OOOOc in the 2022 Supplemental Proposal included the same basic definition for well designated facility, but only included presumptive standards for liquids unloading from gas wells and associated gas from oil wells. This structure is also retained in the final EG OOOOc.

The following sections summarize the final NSPS OOOOb and EG OOOOc. Specifically, section X.F.1 addresses the affected facility and designated facility definitions, section X.F.2 addresses the standards and presumptive standards for associated gas wells, section X.F.3 addresses the standards and presumptive standards for liquids unloading, and section X.F.4 addresses the standards for well completions.

1. Well Affected and Designated Facility Definitions

a. NSPS OOOOb

Well affected facility. Each well affected facility, which is a single well.

(1) In addition to 40 CFR 60.14, a “modification” of an existing well occurs when:

- (i) An existing well is hydraulically fractured, or
- (ii) An existing well is hydraulically refractured.

b. EG OOOOc

Well designated facility. Each well designated facility, which is a single well.

2. Associated Gas From Wells Producing Primarily Oil

a. NSPS OOOOb

i. Affected Facility and Final Work Practice Standards

Each well affected facility that produces associated gas is subject to the standards, where associated gas is defined as natural gas which originates at wells operated primarily for oil production that is released from the liquid hydrocarbon during the initial stage of separation after the wellhead. For the purpose of distinguishing wells operated primarily for oil production that produce associated gas from wells operated primarily for gas production, the EPA refers to the former as associated gas wells in this final rule. To provide additional clarity regarding which wells are affected facilities subject to the associated gas standards, the EPA added a definition of associated gas to this final rule. In order to clearly distinguish associated gas from gas vented during well completion activities, the definition of associated gas specifies that associated gas production begins at the startup of production after the flow back period ends. Further, the EPA has chosen not to define oil wells or gas wells in NSPS OOOOb or EG OOOOc.

The NSPS OOOOb final rule separates new associated gas wells into multiple groups based on when construction is commenced. This grouping serves the purpose of a “phase-in” of the final rule standards which the EPA believes is appropriate in this situation because of certain changes that the EPA made to these standards between the December 2022 Supplemental Proposal and final rule. These groups are: (1) Wells that commence construction after May 7, 2026, (2) wells that commence construction between May 7, 2024 and May 7, 2026, and (3) wells that

commenced construction between December 6, 2022, and May 7, 2024, and wells that are modified or reconstructed after December 6, 2022. The definition of “commenced” within the NSPS general provisions apply for purposes of the NSPS OOOOb. 40 CFR 60.2.

The final work practice standard for all three groups is largely the same. The associated gas must either be recovered from the separator and routed into a gas gathering flow line or collection system to a sales line, recovered from the separator and used as an onsite fuel source, recovered from the separator and used for another useful purpose that a purchased fuel, chemical feedstock, or raw material would serve, or recovered from the separator and reinjected into the well or injected into another well. The final work practice standard for wells in the second and third group, is very similar to what the EPA proposed in the December 2022 Supplemental Proposal, although there are certain limitations that were not included in the supplemental proposal, which we discuss below.

Wells in the first group (*i.e.*, those wells that commence construction after May 7, 2026) are required to route the gas to a sales line, use the gas as an onsite fuel source, for another useful purpose that a purchased fuel, chemical feedstock, or raw material would serve, or reinject it into the well or into another well upon start-up. The final standards do not allow these wells to routinely flare emissions because we have determined that, with advance planning, at least one of the options to avoid routine flaring will be feasible at such wells (including routing the gas to a sales line, using the gas as an onsite fuel source, using the gas for another useful purpose that a purchased fuel, chemical feedstock, or raw material would serve, or reinjecting it into the well or into another well). These sites must handle the associated gas using one of these options, but the final rule still includes provisions to allow short-term flaring for specific circumstances such as safety concerns. The EPA recognizes that this is a change from what was included in the December 2022 Supplemental Proposal because there the EPA proposed to allow certain wells to routinely flare provided they made a technical infeasibility demonstration that was certified. Because of this change at final, the EPA is applying this requirement (no routine flaring) to wells that commence construction later than 24 months after the effective date of this final rule. This additional time beyond the rule’s

effective date will provide owners and operators with a sufficient period to adjust to this change so that they can ensure compliance with the final standard as soon as the well starts to produce associated gas.

Wells in the second group (*i.e.*, wells that commence construction between May 7, 2024 and May 7, 2026) must comply with the final standard of no routine flaring on or before May 7, 2026. At that time, these wells will no longer be allowed to flare routinely with a showing of technical infeasibility, and must route associated gas to a sales line, use the gas for another useful purpose that a purchased fuel, chemical feedstock, or raw material would serve, or reinject the gas into the well or inject it into another well. In the interim period not to exceed 24 months from the effective date of the final rule, these wells may route the associated gas to a flare or control device that reduces methane and VOC emissions by at least 95.0 percent provided the owner/operator can demonstrate that the other control options discussed above are technically infeasible. Again, this will allow for a sufficient phase in period for owners and operators of wells in this group to adjust to the final standard, which is different than what the EPA included in the December 2022 Supplemental Proposal.

For wells in the third group (wells that commenced construction, modified, or reconstructed, between December 6, 2022 (the date that the supplemental proposal published in the **Federal Register**), and May 7, 2024), the final rule allows routing the associated gas to a flare or control device that reduces methane and VOC emissions by at least 95.0 percent on a routine basis, provided that the owner or operator documents and certifies that routing the associated gas to a sales line, using it as onsite fuel or for another beneficial purpose, or injecting/reinjecting it are technically infeasible. This allowance for technical infeasibility is provided for a period of 1 year at a time. Owners and operators of wells in the third group must renew the technical infeasibility determination/certification annually to be able to continue to route the associated gas to a flare or control device.

Table 16 summarizes the different groups of associated gas wells under NSPS OOOOb for purposes of phasing in the final rule standards and when routine flaring is, or is not, allowed for each group.

TABLE 16—SUMMARY OF ALLOWANCE TO ROUTINELY ROUTE ASSOCIATED GAS TO A FLARE OR CONTROL DEVICE FOR NSPS OOOOb

Construction commencement date	Routinely route to flare/control
New well commencing construction after May 7, 2026	Not Allowed.
New well commencing construction between May 7, 2024, and May 7, 2026.	One year upon certification of technical infeasibility. May not exceed 790 days from publication date of the rule. Thereafter no routine flaring allowed.
New well commencing construction between December 6, 2022, and May 7, 2024.	One year upon certification of technical infeasibility. Renewable upon annual recertification.

When associated gas is routed to a flare or control device, the control device must meet all the requirements specified in 40 CFR 60.5412b. See section X.H of this preamble for more information on control device requirements, including requirements for flares. In addition, the CVS routing

the associated gas to the flare or control device must comply with the provisions in 40 CFR 60.5411b(a) and (c).

The EPA recognizes that temporary situations can occur beyond the control of an owner/operator that could make it technically infeasible or unsafe to comply with the standard for a limited

period of time. Therefore, for all wells subject to NSPS OOOOb, the final rule allows owners and operators to route the associated gas to a flare or control device temporarily. Specifically, the final rule allows this for the situations and durations shown in table 17.

TABLE 17—SITUATIONS AND DURATIONS WHERE ASSOCIATED GAS MAY TEMPORARILY BE ROUTED TO A FLARE OR CONTROL DEVICE

Situations where temporary routing associated gas to a flare or control device is allowed	Maximum duration
During a deviation caused by malfunction, including for reasons of safety	24 hours.
During repair, maintenance including blowdowns, a bradenhead test, a packer leakage test, a production test, or commissioning.	24 hours.
During temporary interruption in service from the gathering or pipeline system	30 days.
If associated gas does not meet pipeline specifications	72 hours.

The final rule requires that during any period when associated gas is temporarily routed to a flare, the owner or operator demonstrate that the flare is meeting the requirements in 40 CFR 60.5412b. See section X.H of this preamble for more information on control device standards.

The final rule also allows short-term venting in malfunction situations where flaring the associated gas would cause an unsafe environment. This venting would be limited to 12 hours.

As noted earlier in this preamble, for wells for which construction commenced between December 6, 2022, and May 7, 2024, and for wells that are reconstructed or modified after December 6, 2022, the final rule allows routinely routing the associated gas to a flare or control device that achieves 95.0 percent VOC and methane reduction provided a yearly technical infeasibility demonstration. This means routinely routing the associated gas to a flare or control device is allowed only if the owner or operator demonstrates that all four options included in the work practice standard discussed previously are infeasible due to technical reasons. In order to demonstrate such technical infeasibility, the final rule requires that a detailed analysis be performed, and that documentation be prepared that

demonstrates the technical reasons for this infeasibility. The demonstration must address the technical infeasibility for all options identified in the rule, specifically: (1) Route into a gas gathering flow line or collection system to a sales line, (2) recover from the separator and use as an onsite fuel source, (3) recover from the separator and use for another useful purpose that a purchased fuel, chemical feedstock, or raw material would serve, or (4) recover from the separator and reinject into the well or injected into another well.

The two components of a technical infeasibility demonstration are the list of technologies to be evaluated, and reason that each of technologies is infeasible. The first is the technologies or solutions to be evaluated. For three of the options—route into a gas gathering flow line or collection system to a sales line, recover from the separator and use as an onsite fuel source, reinject into the well or another well—this is straightforward. However, the third option—use the associated gas for another useful purpose that a purchased fuel, chemical feedstock, or raw material would serve—is more open ended.

The final rule does not specify the “other useful purpose” solutions that must be evaluated, but it is the

responsibility of the owner and operator, along with the qualified professional engineer or other qualified personnel performing the evaluation, to ensure that the list of options evaluated is comprehensive to address technically viable solutions.

Technologies that are in the evaluation, pilot-plant, or testing stages are not considered to be technically viable.

In summary, to demonstrate technical infeasibility in order to route to a flare or control device, you must establish that it is not technically feasible to route the associated gas into a gas gathering flow line or collection system to a sales line, and not technically feasible to use the associated gas as an onsite fuel source such as a generator, fuel cell, or other power-producing use, and not technically feasible to reinject into the well or another well, and not technically feasible to utilize “other useful purposes” of the associated gas. A technically viable “other useful purpose” is likely to require the routing of the associated gas to on-site or nearby equipment that compresses, liquifies, or transforms the gas into a physical state that can be transported by pipeline or other transportation mode to an eventual user. A determination of technical infeasibility requires a

showing of site-specific conditions that make these operations infeasible for even the most basic of such uses. One such basic use is capture and truck transportation offsite to a user or processing facility.

The second component of the demonstration is the determination that each of the possibilities is infeasible. While the final rule does not specify criteria for technical infeasibility, the EPA generally characterizes acceptable reasons in the general categories of physical, logistical, or legal factors. Examples could include, but are not limited to, the following. It may be infeasible to connect to a sales line because of inability to secure necessary easements and/or rights-of-way, inability to obtain necessary specialized equipment, inadequate capacity of gathering system to accept the gas, or production sharing contract restrictions. It may be infeasible to use the associated gas as an onsite fuel source because there are no onsite power needs or power needs have been met with less gas than produced, there is insufficient associated gas to support a small electricity generation plant, and there is no local demand for the power. Note that it would be difficult to claim technical infeasibility based on no onsite power needs if the site has equipment that is burning diesel or other fuel which could be replaced by using the associated gas. Reinjection may be infeasible because there is no subsurface reservoir or other storage available for reinjection in the vicinity. To demonstrate that the "other beneficial use" option is not technically feasible an owner or operator could show that there is an observable or demonstrable reason that the operator cannot install equipment to convert associated gas to compressed natural gas (CNG) at the well site due to physical or technical constraints and/or that CNG transport in the region is not available. It is expected that owners and operators will conduct detailed evaluations of all such options. The analysis must show clear evidence that the owner and operator has conducted due diligence to understand the situations where the solution is being successfully utilized and a demonstration of why it is not feasible at their site. Note that the EPA acknowledges that the unavailability of a solution, even one that has been demonstrated at one or more sites in the U.S., is a valid reason for an infeasibility conclusion. One overarching factor that may impact technical feasibility is the composition of the gas. The EPA recognizes that there are situations (e.g., high sulfur content, high CO₂ and low

methane content) where some solutions may be infeasible.

Each infeasibility demonstration must be certified by a qualified professional engineer or other qualified individual with expertise in the uses of associated gas. This certification must state: "I certify that the assessment of technical and/or safety infeasibility was prepared under my direction or supervision. I further certify that the assessment was conducted, and this report was prepared, pursuant to the requirements of 40 CFR 60.5377b(b)(1). Based on my professional knowledge and experience, and inquiry of personnel involved in the assessment, the certification submitted herein is true, accurate, and complete."

Where available, each properly executed infeasibility determination and certification allows the owners and operators of that particular well site to routinely flare the associated gas for a one-year period. While some new and modified sites can make such showings to routinely flare, this mechanism is not available to all new well sites. See table 16 above. In the fast-moving landscape of the oil and natural gas industry, there are a variety of factors that could change the circumstances present when the previous infeasibility determination was performed. For example, a gathering system could have been built or extended in the vicinity of the well, the site could have expanded operations and have a need for onsite power, or a new commercially viable solution could become available. For this reason, the final rule requires that an updated infeasibility determination and certification be performed each year and submitted in the annual compliance report. If an option that was technically infeasible before has since become available, meaning that the reason that such option was technically infeasible before has changed in a way that the option is now feasible, then the owner/operator of the well must utilize that option going forward and must cease routine flaring.

ii. Recordkeeping and Reporting Requirements

For affected facilities, required records include documentation of the specific type(s) of compliance methods used (*i.e.*, routed into a gas gathering flow line or collection system to a sales line, used as an onsite fuel source, used for another useful purpose that a purchased fuel or raw material would serve, reinjected into the well or injected into another well). For those temporary situations where the associated gas must be routed to a flare or control device, owners/operators must document the reason for this

temporary flaring, along with the duration. If the gas is routed to a flare either on a temporary or routine basis, records must be kept demonstrating that flares meet the requirements outlined in 40 CFR 60.5412b. This information must also be reported in the annual report. For those temporary situations where the associated gas is vented due to malfunction situations where flaring or routing to a control device would cause an unsafe environment, the owner or operator must document the reason for this venting, along with the duration, the volume of gas vented, and the VOC and methane emissions. The annual report must include all information for each venting episode.

For wells that properly demonstrate technical infeasibility and therefore routinely route the associated gas to a flare or control device that achieves 95.0 percent reduction in VOC and methane, detailed records must be maintained supporting the infeasibility determination due to technical reasons, along with the signed certification by a qualified professional engineer or other qualified individual. This information must also be included in the annual report. As discussed previously, this demonstration and certification is required to be updated annually.

In addition, all records associated with a demonstration of proper design and operation of the control device, where used, must be maintained (see section X.H of this preamble). For all instances where associated gas is temporarily vented due to malfunction situations where flaring or routing to a control device would cause an unsafe environment, an owner or operator must also document the reason for this venting, along with the duration, the volume of gas vented, and the VOC and methane emissions. The annual report must include all information for each venting episode.

b. EG OOOOc

i. Designated Facility

Consistent with the NSPS OOOOb affected facility, each existing well that produces associated gas which commenced construction before December 6, 2022, is a designated facility for purposes of EG OOOOc. Associated gas is defined as natural gas which originates at wells operated primarily for oil production that is released from the liquid hydrocarbon during the initial stage of separation after the wellhead. To distinguish associated gas from gas vented during the completion activities, the definition of associated gas specifies that associated gas production begins at the

startup of production after the flow back period ends.

ii. Final Work Practice Presumptive Standards

The final EG separates (subcategorizes) existing oil wells with associated gas into two groups based on the amount (mass) of methane in the associated gas. The demarcation between these two groups is 40 tons of methane per year. The presumptive standard in the final EG for wells that produce associated gas with over 40 tpy of methane is the same as what the EPA proposed for existing sources within the 2022 Supplemental Proposal.

The presumptive standard for existing wells that produce associated gas with over 40 tpy of methane is summarized as follows. For these sites, the associated gas must either be recovered from the separator and routed into a gas gathering flow line or collection system to a sales line, recovered from the separator and used as an onsite fuel source, recovered from the separator and used for another useful purpose that a purchased fuel, chemical feedstock, or raw material would serve, or recovered from the separator and reinjected into the well or injected into another well. If all of these options are technically infeasible, then these existing wells (producing associated gas with more than 40 tpy of methane) can route associated gas to a flare or control device that achieve 95.0 percent reduction in methane. The determination of technical infeasibility must be certified by a professional engineer or other qualified personnel, the flare or control device must meet the requirements of 40 CFR 60.5412b, and technical infeasibility must be re-certified on an annual basis. For purposes of this presumptive standard, the EPA intends that technical infeasibility be defined in the same manner as explained above for new sources. See the discussion under the NSPS (see section X.F.1 of this document) related to the requirements for an infeasibility determination and certification.

The presumptive standard in the final EG for wells that produce associated gas with 40 tpy of methane or less is to route associated gas to a flare or control device that achieves 95.0 percent reduction in methane. The difference between the two groups is that, for those existing wells with annual methane in the associated gas greater than 40 tpy, owners and operators are required to demonstrate that it is infeasible for technical reasons to utilize any of the work practice options before they can route associated gas to a flare or control

device. For existing wells that produce associated gas containing 40 tpy or less of methane, flaring or routing to control is allowed without an infeasibility determination and certification. However, existing wells that produce associated gas containing 40 tpy or less of methane can still utilize any of the control options that result in zero emissions to meet the standard.

The EPA has created subcategories for designated facilities because EPA's analysis conducted after reviewing comments on the 2022 Supplemental Proposal indicates that it is not reasonable with respect to cost to require sources that produce less than 40 tpy methane of associated gas to route their associated gas to a sales line. The EPA analyzed the task of routing to a sales line and found that the two factors that controlled whether routing to a sales line was BSER was the distance that a pipeline would need to go to reach the sales line, and the amount of gas that could be recovered as measured at the separator. Over even short distances, the cost of routing to a sales line was not reasonable at very low levels of available associated gas. Given this and the comments that we received on this point, the EPA agreed with commenters that at low levels of associated gas production the flaring of associated gas is the BSER. See the final rule TSD chapter 3 on Associated Gas for further information on the determination of BSER for designated sources.

In order to determine whether the methane contained in the associated gas is 40 tpy or less, owners and operators must utilize a gas-to-oil ratio (GOR)-based method derived from paragraphs 40 CFR 98.234(m)(1) through (4) of GHGRP subpart W. Sources with methane contained in the associated gas greater than 40 tpy, and sources with methane contained in the associated gas 40 tpy or less that elect to comply with one of the work practices, are not required to calculate and document the annual methane content in the associated gas.

iii. Recordkeeping and Reporting

The recordkeeping and reporting requirements included in EG OOOOc are the same as those included in the NSPS OOOOb. Wells that elect to demonstrate that the methane contained in the associated gas is 40 tpy or less are required to maintain records of this calculation and submit it in the annual reports.

3. Gas Well Liquids Unloading Operations

a. NSPS OOOOb

i. Affected Facility

Each well affected facility gas well that undergoes liquids unloading.

ii. Final Standards

Each affected gas well that unloads liquids is required to employ techniques or technology(ies) that minimize or eliminate venting of emissions during liquids unloading events to the maximum extent. For the EPA's rationale for prescribing a work practice standard over a numeric standard, see section XI.F.3.a of this preamble. Owners or operators are also allowed the option to comply with the GHG and VOC standards by reducing methane and VOC emissions from each gas well liquids unloading event by 95 percent by routing emissions to a control device via a CVS.

For unloading technologies or techniques that eliminate venting of emissions during liquids unloading events, the final rule requires minimal recordkeeping and reporting.

For unloading technologies or techniques that could result in venting to the atmosphere, the final rule requires work practices be followed. Specifically, the final rule requires that owners or operators employ and document best management practices to minimize or eliminate venting of methane and VOC emissions for each gas well liquids unloading operation.

Specifically, owners or operators of well affected facilities that are gas wells that unload liquids must develop, maintain, and follow a best management practice plan to eliminate or minimize venting of methane and VOC emissions to the maximum extent possible from each gas well liquids unloading operation. This best management practice plan must meet the following minimum criteria: (1) Include steps that create a differential pressure to minimize the need to vent a well to unload liquids; (2) include steps to reduce wellbore pressure as much as possible prior to opening the well to the atmosphere; (3) unload liquids through the separator where feasible; and (4) close all wellhead vents to the atmosphere and return the well to production as soon as practicable.

The best management practice plan that provides steps to minimize or eliminate venting of emissions would apply for both planned venting events and unintended/unplanned venting events due to malfunctions or error. In some instances, depending on the non-venting liquids unloading technology or

technique employed, the best management plan for planned and unplanned events may differ. In such cases, an owner or operator may choose to develop a separate plan to cover unplanned events. However, to minimize emissions, depending on technology or technique employed, the same minimum best management practice criteria should apply, *i.e.*: (1) Include steps that create a differential pressure to minimize the need to vent a well to unload liquids; (2) include steps to reduce wellbore pressure as much as possible prior to opening the well to the atmosphere; (3) unload liquids through the separator where feasible; and (4) close all wellhead vents to the atmosphere and return the well to production as soon as practicable. Where a planned or unplanned event occurs where best management practices were unable to be followed, an owner or operator is required to report those events as deviations. Specifically, owners or operators are required to report the number of liquids unloading events during the year where deviations from your best management practice plan occurred, the date and time the deviation began, the duration of the deviation in hours, documentation of why best management practice plan steps were not followed, and what steps, in lieu of your best management practice plan steps, were followed to minimize emissions to the maximum extent possible.

For owners or operators that comply with the GHG and VOC standards by reducing methane and VOC emissions from each gas well liquids unloading event by 95 percent by routing emissions to a control device via a CVS, an owner or operator is required to maintain records and report that it is complying by using this option. In instances where a deviation from the standard has occurred during the reporting period, an owner or operator would be required to provide information on the date and time the deviation began, the duration of the deviation, and a description of the deviation. Additionally, the dates of each cover and CVS inspection, whether emissions are identified, and the date of repair or the date of anticipated repair if repair is delayed would be required in the annual report. Where bypass requirements apply, the date and time of each bypass alarm or each instance the key is checked out would be included in the annual report. For the reports and records that must be maintained to demonstrate proper design and operation of the control device, see

sections X.H.1 and X.H.2 of this preamble.

iii. Recordkeeping and Reporting Requirements

For each gas well liquids unloading operation where the technique/technology employed eliminates venting to the atmosphere, owners or operators are only required to maintain the identification of the well affected facility and the zero-emitting technology or technique used; and the number of liquids unloading events conducted during the reporting period that had unplanned venting events (if any) that required that they employ best management practices to minimize emissions to the maximum extent possible during the unplanned event. As noted previously, any unplanned venting events would be subject to the required best management practices and associated recordkeeping and reporting requirements for those events.

For each gas well liquids unloading operation where emissions are vented to the atmosphere, owners or operators of affected facilities are required to keep the following records: (1) Identification of each well affected facility that conducted liquids unloading during the reporting period that vented to the atmosphere; (2) the number of liquids unloading events during the reporting period that vented to the atmosphere; (3) documentation of your best management practice plan developed that meets the criteria specified in 40 CFR 60.5376b(d) of the final NSPS OOOOb; (4) a log of each best management practice plan step taken to minimize emissions to the maximum extent possible for each gas well liquids unloading event; and (5) documentation of each gas well liquids unloading event where deviations from your best management practice plan steps occurred, the date and time the deviation began, the duration of the deviation, documentation of best management practice plans steps were not followed, and the steps taken in lieu of your best management practice plan steps during those events to minimize emissions to the maximum extent possible. These requirements apply for both planned and unintended/unplanned venting events due to malfunctions or error.

For each well affected facility where gas well liquids unloading operations are conducted, an annual report is required to include a summary of the information required to be maintained.

b. EG OOOOc

i. Designated Facility

Each well designated facility gas well that undergoes liquids unloading.

ii. Final Presumptive Standards and Recordkeeping and Reporting Requirements

The work practice standards and recordkeeping and reporting requirements for well designated facilities that undergo gas well liquids unloading under EG OOOOc are the same as those finalized for NSPS OOOOb.

4. Well Completions

a. NSPS OOOOb

i. Affected Facility

Each well affected facility well completion of hydraulically fractured (or refractured) wells.

ii. Final Standards

For well completion of hydraulically fractured (or refractured) wells, there are two subcategories of hydraulically fractured wells for which well completions are conducted: (1) Non-wildcat and non-delineation wells (subcategory 1 wells); and (2) wildcat and delineation wells, and non-wildcat and non-delineation low-pressure wells (subcategory 2 wells). A wildcat well is a well drilled outside known fields or is the first well drilled in an oil or gas field where no other oil and gas production exists. A delineation well is a well drilled to determine the boundary of a field or producing reservoir.

For non-wildcat and non-delineation wells (subcategory 1 wells), owners or operators are required to use a combination of reduced emissions completion (REC) equipment/practices and a completion combustion device to control emissions from a completion event. For each flowback stage (*i.e.*, initial flowback stage, separation flowback stage) of the well completion, the EPA specifies requirements in the final rule. During the initial flowback stage, owners or operators are required to route the flowback to a storage vessel or completion vessel (frac tank, lined pit, or other vessel) and separator. During the separation flowback stage, owners or operators are required to route all salable gas from the separator to a gas flow line or collection system, re-inject the gas into the well or another well, use the gas as an onsite fuel source or use for another useful purpose that a purchased fuel or raw material would serve. If technically infeasible to route recovered gas as specified previously, recovered gas must be combusted. All

liquids, during the separation phase, must be routed to a storage vessel or well completion vessel, collection system, or be reinjected into the well or another well. The final rule requires the operator to have the separator available and to use the separator for the entirety of flowback, either by having the separator on-site or at a nearby centralized facility or well pad that services the well affected facility. A well that is not hydraulically fractured or refractured with liquids, or that does not generate condensate, intermediate hydrocarbon liquids, or produced water such that there is no liquid collection system at the well site is not required to have a separator on-site or at a centralized production facility or well pad that services the well completion well affected facility.

For each wildcat and delineation well, and non-wildcat and non-delineation low pressure wells (subcategory 2 wells), owners or operators must either: (1) Route all flowback to a completion combustion device equipped with a continuous pilot flame; or (2) route all flowback into one or more well completion vessels and commence operation of a separator unless it is technically infeasible for a separator to function. Gas recovered from the separator must be captured and routed to a completion combustion device equipped with a continuous pilot flame. Option (2) may only be used where the owner or operator is able to operate a separator, and the separator must be available (onsite or otherwise available for use) and must be used for the entirety of flowback. For both options (1) and (2), combustion is not required in conditions that may result in a fire hazard or explosion, or where high heat emissions from a completion combustion device may negatively impact tundra, permafrost, or waterways.

Oil wells with a gas-to-oil ratio less than 300 scf of gas per stock tank barrel of oil produced are well affected facilities but have no requirements other than to maintain records of the low GOR certification and a claim signed by the certifying official.

iii. Recordkeeping and Reporting Requirements

Owners or operators of a well affected facility must notify the Administrator no later than 2 days prior to the commencement of each well completion operation listing the anticipated date of the well completion operation. If an owner or operator is subject to state regulations that require advance notification of well completions and you have met those notification

requirements, then you are considered to have met the advance notification requirements of the final rule.

Owners or operators of well affected facilities must maintain a log for each well completion operation at each well affected facility. The log must be completed daily for the duration of the well completion operation and must contain specified record information (see 40 CFR 60.5420b(c)(1)(iii)).

Annual reports are required to include general information for all well affected facility reports, and for each well affected facility subject to well completion requirements. Owners or operators are required to maintain records and report information regarding each well completion operation conducted during the reporting period, including the location of the well, type of well, duration of completion event, and information related to the well completion itself (e.g., actions taken to mitigate emissions). Additionally, if venting occurs, the annual report is required to include the specific reasons for venting in lieu of capture or combustion, as well as any deviations recorded (i.e., the date and time the deviation began, the duration of the deviation in hours, and a description of the deviation).

For each well affected facility that is an oil well with a gas-to-oil ratio less than 300 scf of gas per stock tank barrel of oil produced, the annual report must include a record of the well type (i.e., wildcat well, delineation well, or low-pressure well) and supporting inputs and calculations, if applicable. The records required to be maintained by the owner or operator include: (1) A record of the analysis performed in order to make that claim, including but not limited to, GOR values for established leases and data from wells in the same basin and field; (2) the latitude and longitude of the well in decimal degrees to an accuracy and precision of five decimals of a degree using North American Datum of 1983; (3) the United States Well Number; and (4) a record of the claim signed by the certifying official.

For each well meeting affected facility claiming an exemption at 40 CFR 60.5375b(h) for a well modified in accordance with 40 CFR

60.5365b(a)(1)(ii) (i.e., an existing well that is hydraulically refractured), the annual report must include a statement that the well completion operation requirements of 40 CFR 60.5375b(a)(1) through (3) were met. Records required to be maintained include: (1) A record of the latitude and longitude of the well in decimal degrees to an accuracy and precision of five decimals of a degree

using North American Datum of 1983; (2) the United States Well Number; (3) the date and time of the onset of flowback following hydraulic fracturing or refracturing; and (4) a record of the claim that the well completion operation requirements of 40 CFR 60.5375b(a)(1) through (3) were met.

b. EG OOOOc

Because the fracturing or re-fracturing of an existing well would constitute a modification under NSPS OOOOb, it would make the existing well a well affected facility under NSPS OOOOb. Thus, no requirements are specified for well completions under EG OOOOc.

G. Centrifugal Compressors

1. NSPS OOOOb

a. Affected Facility

The centrifugal compressor affected facility is defined as a single centrifugal compressor. A centrifugal compressor located at a well site is not a centrifugal compressor affected facility under NSPS OOOOb. A centrifugal compressor located at a centralized production facility is a centrifugal compressor affected facility under NSPS OOOOb.

b. Final Standards

Centrifugal compressor affected facilities with wet seals must comply with the GHG and VOC standards by reducing methane and VOC emissions from each centrifugal compressor wet seal fluid degassing system by 95 percent by routing emissions via a CVS to a control device. As an alternative to routing the CVS to a control device, an owner or operator may also route the CVS to a process. If an owner or operator chooses to comply with this requirement either by using a control device to reduce emissions or by routing to a process to reduce emissions, an owner must equip the wet seal fluid degassing system with a cover and the cover must be connected through a CVS meeting specified requirements, such as design and operation with no identifiable emissions.

For specified centrifugal compressors (i.e., self-contained wet seal compressor, wet seal compressor equipped with a mechanical seal, centrifugal compressors equipped with sour seal oil separator and capture system, centrifugal compressors equipped with dry seals), an owner or operator has the option to comply with the rule by meeting the following work practice performance-based volumetric flow rate standards in lieu of requiring that emissions be routed to a control device or process:

(1) If an owner or operator uses a self-contained wet seal centrifugal compressor or a wet seal compressor equipped with a mechanical seal, an owner or operator must conduct monitoring and repair of the wet seal (as necessary) to maintain volumetric flow rate at or below 3 standard cubic feet per minute (scfm), in operating or standby pressurized mode, per seal. The volumetric flow rate of 3 scfm is an action level that, if exceeded, triggers the requirement to repair or replace the seal and is not a numeric limit.

(2) Owners or operators of centrifugal compressors on the Alaska North Slope that are equipped with a seal oil recovery system (*i.e.*, centrifugal compressors equipped with sour seal oil separator and capture system, such as a seal oil gas separation system that separates gas from the sour seal oil exiting the compressor seal assembly, upstream from the degassing drum) must conduct monitoring and repair of the wet seal (as necessary) to maintain a volumetric flow rate at or below 9 scfm (in operating or standby pressurized mode) per seal. The volumetric flow rate of 9 scfm is an action level that, if exceeded, triggers the requirement to repair or replace the seal and is not a numeric limit.

(3) If an owner or operator uses a centrifugal compressor equipped with a dry seal, an owner or operator must conduct monitoring and repair of the dry seal to maintain a volumetric flow rate at or below 10 scfm (in operating or standby pressurized mode) per seal. The volumetric flow rate of 10 scfm is an action level that, if exceeded, triggers the requirement to repair or replace the seal and is not a numeric limit. In addition to the volumetric flow rate monitoring required every 8,760 hours of operation, additional preventative (maintenance) or corrective measures may be required to maintain compliance with the centrifugal compressor wet and dry seal volumetric flow rate performance standard. Specifically, if the volumetric flow rate measured exceeds the flowrate specified for a centrifugal compressor seal, the seals connected to the measured vent must be repaired. Seal repair must be conducted within 90 calendar days from the date of the volumetric emissions measurement. If the repair of the wet or dry seal is technically infeasible, would require a vent blowdown, a compressor station shutdown, or would be unsafe to repair during operation of the unit, the repair can be delayed but must be completed during the next scheduled compressor station shutdown for maintenance, after a scheduled vent blowdown, or within 2 years, whichever

is earliest. A vent blowdown is the opening of one or more blowdown valves to depressurize major production and processing equipment, other than a storage vessel. In addition, if the repair requires replacement of the compressor seal or a part thereof, but the necessary replacement seal or part cannot be acquired and installed within the repair timelines specified due to supplies being unavailable (where previously sufficiently-stocked), a delay of repair is allowed. However, in order to qualify for a delay of repair, the required seal or part replacement must be ordered no later than 10 calendar days after the centrifugal compressor seal is added to the delay-of-repair list due to parts unavailability.

Owners or operators must conduct volumetric flow rate measurements from each centrifugal compressor wet and dry seal vent within 15 days after the repair to document that the rate has been reduced to less than applicable flow rate per seal. If the individual seals are manifolded to a single open-ended vent line, the volumetric flow rate must be reduced to less than the sum of the individual seals multiplied by the applicable required flow rate per seal.

For the EPA's rationale for prescribing a work practice standard over a numeric standard, see section XI.G.2 of this preamble.

c. Recordkeeping and Reporting Requirements

For a centrifugal compressor affected facility complying by routing emissions from the wet seal degassing system to a process through a CVS, an owner or operator is required to maintain records and report that it is complying by using this option. In instances where a deviation from the standard has occurred during the reporting period, an owner or operator would be required to provide information on the date and time the deviation began, the duration of the deviation, and a description of the deviation. Additionally, they would be required to report of the dates of each cover and CVS inspection, whether emissions are identified, and the date of repair or the date of anticipated repair if repair is delayed would be included in the annual report. Where bypass requirements apply, the date and time of each bypass alarm or each instance the key is checked out would be included in the annual report.

For a centrifugal compressor affected facility complying by routing emissions from the wet seal degassing system to a control device through a CVS, an owner or operator is required to maintain records and report that it is complying by using this option. In instances where

a deviation from the standard has occurred during the reporting period, an owner or operator would be required to provide information on the date and time the deviation began, the duration of the deviation, and a description of the deviation. Additionally, the dates of each cover and CVS inspection, whether emissions are identified, and the date of repair or the date of anticipated repair if repair is delayed would be required in the annual report. Where bypass requirements apply, the date and time of each bypass alarm or each instance the key is checked out would be included in the annual report. For the reports and records that must be maintained to demonstrate proper design and operation of the control device, see sections X.H.1 and X.H.2 of this preamble.

Owners or operators complying with a performance-based emissions standard for specified centrifugal compressors equipped with wet seals and dry seals must track and report in their annual report the cumulative number of hours of operation of each centrifugal compressor since startup, or since the previous screening/volumetric flow rate emissions measurement, as applicable. The annual report must also include a description of the method used and the results of the volumetric flow rate measurement or emissions screening, as applicable. Lastly, owners or operators must maintain records and report each measurement that exceeds the applicable performance-based emissions standard per seal during the reporting period, and the date and time the compressor seal was repaired to meet the required performance-based emissions standard per seal. In the case of delay of repair due to parts unavailability, operators must document the date the centrifugal compressor was added to the delay-of-repair list, the date the replacement seal or part thereof was ordered, the anticipated delivery date, and the actual delivery date; and the annual report needs to provide the reason for the needed delay and the date of anticipated repair.

2. EG OOOOc

a. Designated Facility

The centrifugal compressor designated facility is defined as a single centrifugal compressor. A centrifugal compressor located at a well site is not a centrifugal compressor designated facility under EG OOOOc. A centrifugal compressor located at a centralized production facility is a centrifugal compressor designated facility under EG OOOOc.

b. Final Presumptive Standards

For centrifugal compressor designated facilities with wet seals (including self-contained wet seal centrifugal compressors and centrifugal compressors equipped with mechanical seals) the presumptive GHG standards are work practice performance-based volumetric flow rate standards. These designated facilities must reduce methane emissions by maintaining a volumetric flow rate at or below 3 scfm (in operating or standby pressurized mode) per seal. Centrifugal compressors designated facilities operating on the Alaska North Slope that are equipped with a seal oil recovery system (*i.e.*, centrifugal compressors equipped with sour seal oil separator and capture system, such as a seal oil gas separation system that separates gas from the sour seal oil exiting the compressor seal assembly, upstream from the degassing drum) must maintain a volumetric flow rate at or below 9 scfm (in operating or standby pressurized mode) per seal. The volumetric flow rates of 3 and 9 scfm are action levels that, if exceeded, trigger the requirement to repair or replace the seal and are not numeric limits.

Centrifugal compressor designated facilities with dry seals must maintain a volumetric flow rate at or below 10 scfm (in operating or standby pressurized mode) per seal. The volumetric flow rate of 10 scfm is an action level that, if exceeded, triggers the requirement to repair or replace the seal and is not a numeric limit.

In addition to the flow rate monitoring required every 8,760 hours of operation, additional preventative (maintenance) or corrective measures may be required to maintain compliance. Specifically, if the volumetric flow rate measured exceeds the flowrate specified for a centrifugal compressor seal, the seals connected to the measured vent must be repaired. Seal repair must be conducted within 90 calendar days from the date of the volumetric emissions measurement. If the repair of the wet or dry seal is technically infeasible, would require a vent blowdown, would require a compressor station shutdown, or would be unsafe to repair during operation of the unit, the repair can be delayed but must be completed during the next scheduled compressor station shutdown for maintenance, after a scheduled vent blowdown, or within 2 years, whichever is earliest. A vent blowdown is the opening of one or more blowdown valves to depressurize major production and processing equipment, other than a storage vessel. In addition, if the repair

requires replacement of the compressor seal or a part thereof, but the necessary replacement seal or part cannot be acquired and installed within the repair timelines specified due to supplies being unavailable (where previously sufficiently-stocked), a delay of repair is allowed. However, in order to qualify for a delay of repair, the required seal or part replacement must be ordered no later than 10 calendar days after the centrifugal compressor seal is added to the delay-of-repair list due to parts unavailability.

Owners or operators must conduct volumetric flow rate measurements from each centrifugal compressor wet and dry seal vent within 15 days after the repair to document that the rate has been reduced to less than applicable flow rate per seal. If the individual seals are manifolded to a single open-ended vent line, the volumetric flow rate must be reduced to less than the sum of the individual seals multiplied by the applicable required flow rate per seal.

Owners or operators must conduct volumetric flow rate measurements from each centrifugal compressor wet and dry seal vent within 15 days after the repair to document that the rate has been reduced to less than applicable flow rate per seal. If the individual seals are manifolded to a single open-ended vent line, the volumetric flow rate must be reduced to less than the sum of the individual seals multiplied by the applicable required flow rate per seal.

For the EPA's rationale for prescribing a work practice standard over a numeric standard, see section XI.G.2 of this preamble.

As an alternative, an owner or operator may reduce methane emissions from each centrifugal compressor wet seal fluid degassing system or dry seal system by 95 percent by routing emissions via a CVS to a control device, or by routing emissions via a CVS to a process. If an owner or operator chooses to comply with the requirement either by using a control device to reduce emissions or by routing to a process to reduce emissions, an owner or operator must equip the wet seal fluid degassing system with a cover and the cover must be connected through a CVS meeting specified requirements, such as design and operation with no identifiable emissions.

c. Recordkeeping and Reporting Presumptive Work Practice Requirements

Owners or operators complying with a performance-based emissions standard must track and report in their annual report the cumulative number of hours of operation of each centrifugal

compressor since startup, or since the previous screening/volumetric flow rate emissions measurement, as applicable. The annual report must also include a description of the method used and the results of the volumetric flow rate measurement or emissions screening, as applicable. Lastly, owners or operators must maintain records and report each measurement that exceeds the applicable performance-based emissions standard per seal standard during the reporting period, and the date and time the compressor wet or dry seal was repaired to meet the applicable performance-based emissions standard. Where a delay of repair is needed, the annual report needs to provide the reason for the needed delay and the date of anticipated repair.

For a centrifugal compressor designated facility complying with the routing emissions from the wet seal compressor degassing system to a process through a CVS, an owner or operator is required to maintain records and report each centrifugal compressor during the reporting period that is complying by using this option. In instances where a deviation from the standard has occurred during the reporting period, an owner or operator would be required to provide information on the date and time the deviation began, the duration of the deviation, and a description of the deviation. Additionally, the dates of each cover and CVS inspection, whether emissions are identified, and the date of repair or the date of anticipated repair if repair is delayed would be included in the annual report. Where bypass requirements apply, the date and time of each bypass alarm or each instance the key is checked out would be included in the annual report.

For a centrifugal compressor designated facility complying with the routing emissions from the wet seal fluid degassing system to a control device through a CVS, an owner or operator is required to maintain records and report each centrifugal compressor during the reporting period that is complying by using this option. In instances where a deviation from the standard has occurred during the reporting period, an owner or operator would be required to provide information on the date and time the deviation began, the duration of the deviation, and a description of the deviation. Additionally, they would be required to report the dates of each cover and CVS inspection, whether emissions are identified, and the date of repair or the date of anticipated repair if repair is delayed. Where bypass requirements apply, the date and time of

each bypass alarm or each instance the key is checked out would be included in the annual report. For the reports and records that must be maintained to demonstrate proper design and operation of the control device, see sections X.H.1 and X.H.2 of this preamble.

A. Combustion Control Devices

1. NSPS OOOOb

a. Compliance Assurance Requirements

NSPS OOOOb contains various compliance requirements to ensure that combustion control devices that are being used to meet a 95 percent emission reduction standard can continuously demonstrate this level of control of emissions from affected facilities. Except as noted in section XI.H of this preamble, the final compliance assurance requirements for combustion control devices reflect the requirements that were proposed in the December 2022 Supplemental Proposal.¹⁹² This section of the preamble presents a summary of the final requirements for combustion control devices.

Except for boilers and process heaters that introduce the vent stream with the primary fuel into the flame zone and flares, combustion control devices must demonstrate compliance with this control efficiency¹⁹³ through a performance test, which must be repeated every 5 years. In lieu of conducting the initial performance test, owners and operators may purchase an enclosed combustion device that is tested by the manufacturer according to procedures outlined in 40 CFR 60.5413b(d). For combustion devices where temperature is an indicator of destruction efficiency (e.g., incinerators), the owner or operator must establish a temperature limit during the performance test and continuously monitor the temperature after the performance test. Owners and operators using catalytic vapor incinerators must establish a limit on the temperature at the inlet of the catalyst bed and the temperature differential across the catalyst bed during the performance test and continuously monitor these temperatures after the performance test. For all other enclosed combustion devices and flares, the owner and

operator must maintain the net heating value (NHV) of the gas sent to the device above a minimum amount if the combustion device is pressure-assisted or uses no assist gas. If an owner or operator uses a steam-assisted enclosed combustion device, the owner or operator must maintain the combustion zone NHV above a minimum level. If the owner or operator uses an air-assisted enclosed combustion device, the owner or operator must maintain the NHV dilution parameter above a minimum level. The combustion zone NHV and NHV dilution parameter terms account for the reduction in heating value caused by the introduction of air and/or steam. These terms ensure that the assist gas does not overwhelm the heating value provided by the vent gas to the point where proper combustion is no longer occurring.

All flares and all enclosed combustion devices, other than boilers and process heaters that introduce the vent stream with the primary fuel into the flame zone and catalytic incinerators, must operate above a minimum flow rate established by the manufacturer. Additionally, the flow rate to a flare must be maintained at a level that ensures compliance with the flare tip velocity limits in the 40 CFR part 60 General Provisions, and the flow rate to an enclosed combustion device must be below a maximum flow rate established during the performance test or by the manufacturer, if the initial performance test is performed by the manufacturer. Flares and enclosed combustion devices that use pressure-assisted tips to promote mixing at the burner tip are not subject to this maximum flow rate limit because these units are designed to operate at high flow rates.

All flares and all enclosed combustion devices must also operate with a continuous burning pilot flame and with no visible emissions, except for periods not to exceed a total of 1 minute during any 15-minute period. Compliance with the visible emissions requirement can be confirmed either through monthly testing using EPA Method 22 or through continuous use of a video surveillance camera. Additionally, during each fugitive emissions inspection conducted using an OGI camera, including those conducted in response to periodic screening events using alternative technologies, owners and operators must observe each enclosed combustion device and flare to determine if it is operating properly, ensuring that a flame is present and that there is no indication of uncontrolled emissions. During each fugitive emissions inspection conducted using AVO,

owners and operators must observe each enclosed combustion device and flare to determine if it is operating properly, visually confirming that the pilot flame is lit and operating properly.

Owners and operators also have the option to request an alternative test method to demonstrate continuous 95.0 percent control of emissions. In this option, the owner or operator would demonstrate that the combustion device continuously achieves 95.0 percent combustion efficiency or that the combustion device continuously complies with the combustion zone NHV and NHV dilution parameter requirements. The alternative test method would be used in lieu of the other monitoring required for combustion device (e.g., vent gas NHV, flow rate).

b. Recordkeeping and Reporting Requirements

Owners and operators are required to maintain records and report the results of all performance tests conducted on combustion control devices. Additionally, for each continuous parameter monitoring system (CPMS) that is used to demonstrate continuous compliance for a combustion control device, owners and operators must report the identity of the CPMS, the date of last calibration, and the date, duration, and cause of all deviations. Owners and operators must also record and report the date, duration, and cause of events where emissions bypassed the control device and any period when visible emissions exceeded 1 minute during a 15-minute period. For each visible emissions test following return to operation from a maintenance or repair activity, owners and operators must record and report the date of the visible emissions test, the length of the test in minutes, and the number of minutes for which visible emissions were present.

If an owner or operator conducts a demonstration to prove that the NHV of the inlet gas to an enclosed combustion device or flare is consistently above the minimum required NHV, the owner or operator must record and report the results of the demonstration. Likewise, if an owner or operator conducts a demonstration that the maximum potential pressure of units manifolded to an enclosed combustion device or flare cannot cause the maximum inlet flow rate or the flare tip velocity limit to be exceeded, the owner or operator must record and report the results of the demonstration.

In addition to the information that must be reported, owners and operators must keep records of continuous

¹⁹² See section IV.H, 87 FR 74792 (December 6, 2022).

¹⁹³ Alternatively, the performance test can demonstrate compliance with a total organic compounds outlet concentration of 275 ppmv on a wet basis, as propane. See section XI.H.1 of this preamble for more information on the alternative outlet concentration limit.

compliance with the monitoring requirements, including indications that the pilot flame is lit, CPMS limits, CPMS hourly and average values, and results of visible emissions observations or surveillance camera feed. Owners and operators are also required to keep records of CPMS checks and audits, maintenance activities and repairs for each control device failing a visible emissions test, and the manufacturer's written operating instructions, procedures, and maintenance schedule to ensure good air pollution control practices for minimizing emissions. If an owner or operator uses a backpressure regulator valve to control the minimum flow rate to the combustion device, the owner or operator must keep records of the engineering evaluation and manufacturer specifications used to identify the set point and annual confirmation that the backpressure regulator valve set point is set correctly and that the valve fully closes when not in open position.

2. EG OOOOc

a. Compliance Assurance Requirements

The compliance requirements for combustion control devices on designated facilities specified in EG OOOOc are almost identical to the requirements specified in the NSPS OOOOb final rule. The only difference between the requirements in NSPS OOOOb and EG OOOOc is that for enclosed combustion devices and flares that are air-assisted or steam-assisted, the owner and operator would be required to maintain the NHV of the gas sent to the device above a minimum amount instead of monitoring the combustion zone NHV and the NHV dilution parameter. See section XI.H.5 of this preamble for more information on monitoring steam-assisted and air-assisted enclosed combustion devices and flares.

b. Recordkeeping and Reporting Requirements

The EG OOOOc recordkeeping and reporting requirements for combustion control devices on designated facilities specified in EG OOOOc are the same as those specified in the NSPS OOOOb final rule.

I. Reciprocating Compressors

1. NSPS OOOOb

a. Affected Facility

The reciprocating compressor affected facility is each reciprocating compressor, which is a single reciprocating compressor. A reciprocating compressor located at a

well site is not a reciprocating compressor affected facility under this subpart. A reciprocating compressor located at a centralized production facility is a reciprocating compressor affected facility under this subpart.

b. Final Standards

The NSPS OOOOb standard of performance for reciprocating compressor affected facilities is a performance-based emissions standard of 2 scfm (in operating or standby pressurized mode) per cylinder. The volumetric flow rate of 2 scfm is an action level that, if exceeded, triggers the action of repairing or replacing the rod packing and is not a numeric limit. The volumetric flow rate measurement from each reciprocating rod packing must be maintained to be less than or equal to a flow rate of 2 scfm (in operating or standby pressurized mode) per cylinder. An owner or operator is required to repair or replace the rod packing and to conduct other necessary repair and maintenance in order to ensure the emission rate is maintained at or below 2 scfm (in operating or standby pressurized mode) per cylinder. Owners and operators must conduct volumetric flow rate measurements from each reciprocating compressor rod packing using the screening and monitoring methods specified in 40 CFR 60.5386b.

The EPA is requiring that the first and subsequent volumetric flow rate measurements from a reciprocating compressor affected facility be conducted on or before 8,760 hours of operation after the effective date of the final rule, on or before 8,760 hours of operation after the previous flow rate measurement, or on or before 8,760 hours of operation after the date of the most recent compressor rod packing replacement, whichever is later. Preventative maintenance or other corrective actions (e.g., repair or replacement of rod packing) may be necessary in addition to monitoring every 8,760 hours of operation for owners or operators to ensure compliance (consistent with the general duty clause 40 CFR 60.5470b(b)) with the required flow rate of 2 scfm (in operating or standby pressurized mode) or less per cylinder). As an alternative to conducting required volumetric flow rate measurements, the final rule also allows an owner or operator the option to comply by replacing the rod packing on or before 8,760 hours of operation after the effective date of the final rule, on or before 8,760 hours of operation after the previous flow rate measurement, or on or before 8,760 hours of operation after the date of the

most recent compressor rod packing replacement, whichever is later.

In the final rule, repair or replacement of the rod packing is required when the volumetric emission measurement of the reciprocating compressor rod packing has a flow rate greater than 2 scfm (in operating or standby pressurized mode) per cylinder or a combined rod packing flow rate greater than the number of compressor cylinders multiplied by 2 scfm. An owner or operator must repair or replace the reciprocating compressor rod packing within 90 calendar days from the date of the volumetric emissions measurement.

The final rule allows for a delay of repair if the repair or replacement would require a vent blowdown, or it would otherwise be infeasible or unsafe, until the next process unit shutdown. Specifically, if the repair or replacement is technically infeasible, would require a vent blowdown, a process unit or facility requires shutdown, parts or materials are unavailable, or it would be unsafe to repair during operation of the unit, the repair can be delayed but must be completed during the next scheduled process unit or facility shutdown for maintenance, after a scheduled vent blowdown, or within 2 years, whichever is earliest. In addition, if the repair requires replacement of the compressor rod packing or a part, but the necessary replacement rod packing or part cannot be acquired and installed within the repair timelines specified due to supplies being unavailable (where previously sufficiently-stocked), a delay of repair is allowed. However, in order to qualify for a delay of repair, the required rod packing or part replacement must be ordered no later than 10 calendar days after the reciprocating compressor is added to the delay-of-repair list due to parts unavailability.

Owner or operators must conduct volumetric flow rate measurements from each reciprocating compressor vent within 15 days after the repair to document that the rate has been reduced to less than the applicable flow rate per cylinder. If the individual cylinders are manifolded to a single open-ended vent line, the volumetric flow rate must be reduced to less than the sum of the individual cylinders multiplied by the applicable required flow rate per cylinder.

For the EPA's rationale for prescribing a work practice standard over a numeric standard, see section XI.I.1 of this preamble.

c. Routing Emissions From the Rod Packing to a Process or to a Control Device That Reduces Emissions by 95 Percent

Alternatively, an owner or operator may choose to comply with NSPS OOOOb by routing emissions from the rod packing via a CVS to a process or to a control device achieving 95 percent control. These options achieve emissions reductions greater than or equal to the 2 scfm performance-based emissions standard per cylinder. An owner or operator must ensure that the CVS is designed to capture and route all gases, vapors, and fumes to a process (40 CFR 60.5411b(a) and (c)).

An owner or operator complying with the alternative option to route to a process is required to design and operate the CVS with no identifiable emissions and would be subject to bypass requirements (as applicable). Initial, monthly, and annual inspections (using OGI, EPA Method 21, or AVO (for monthly inspections only)) are required to check for defects and identifiable emissions.

An owner or operator complying with the alternative option to route to a control device is required to design and operate the CVS with no identifiable emissions and would be subject to bypass requirements (as applicable). Initial, monthly, and annual inspections (using OGI, EPA Method 21, or AVO (for monthly inspections only)) of the CVS are required to check for defects and identifiable emissions. Control devices are required to meet the conditions specified in 40 CFR 60.5412b of the final rule.

d. Recordkeeping and Reporting Requirements

Owners or operators complying with the performance-based emissions standard must track and report in their annual report the cumulative number of hours of operation of each reciprocating compressor since startup, since the previous screening/volumetric flow rate emissions measurement, or since the previous reciprocating compressor repair/replacement of rod packing, as applicable. Their annual report must also include a description of the method used and the results of the volumetric flow rate measurement or emissions screening, as applicable. Lastly, owners or operators must maintain records and report each measurement that exceeds the 2 scfm performance-based emissions standard per cylinder standard during the reporting period, and the date and time the reciprocating compressor was repaired or packing replaced to meet the 2 scfm performance-based emissions

standard. In the case of delay of repair due to parts unavailability, operators must document the date the reciprocating compressor was added to the delay-of-repair list, the date the required rod packing or part was ordered, the anticipated delivery date, and the actual delivery date; and the annual report needs to provide the reason for the needed delay and the date of anticipated repair or replacement.

For a reciprocating compressor affected facility complying by routing emissions from the rod packing to a process through a CVS, an owner or operator is required to maintain records and report each reciprocating compressor that was constructed, modified, or reconstructed during the reporting period that is complying by using this option. Owners or operators must maintain records and report each deviation from the performance-based emissions standard that occurred during the reporting period, the date and time the deviation began, duration of the deviation and a description of the deviation. Additionally, they would be required to report (in the annual report) the dates of each cover and CVS inspection, whether emissions are identified, and the date of repair or the date of anticipated repair if repair is delayed. Where bypass requirements apply, the date and time of each bypass alarm or each instance the key is checked out would also be included in the annual report.

For a reciprocating compressor affected facility complying by routing emissions from the rod packing to a control device through a CVS, an owner or operator is required to maintain records and report each reciprocating compressor that was constructed, modified, or reconstructed during the reporting period that is complying by using this option. In instances where a deviation from the standard has occurred during the reporting period, an owner or operator would be required to provide information on the date and time the deviation began, the duration of the deviation, and a description of the deviation. Additionally, they would be required to report (in the annual report) the dates of each cover and CVS inspection, whether emissions are identified, and the date of repair or the date of anticipated repair if repair is delayed. Where bypass requirements apply, the date and time of each bypass alarm or each instance the key is checked out would also be included in the annual report. For the reports and records that demonstrate proper design and operation of the control device that must be maintained, see sections X.H.1 and X.H.2 of this preamble.

2. EG OOOOc

a. Designated Facility

The reciprocating compressor designated facility is each reciprocating compressor, which is a single reciprocating compressor. A reciprocating compressor located at a well site is not a reciprocating compressor designated facility under this subpart. A reciprocating compressor located at a centralized production facility is a reciprocating compressor designated facility under this subpart.

b. Final Presumptive Standards

The presumptive standards for reciprocating compressor designated facilities are the same performance-based emissions work practice standard, or alternative routing emissions from the rod packing to a process or control device options as required in the NSPS OOOOb final rule. The final designated facility recordkeeping and reporting requirements specified in the final EG OOOOc rule are also the same as specified in the NSPS OOOOb final rule.

J. Storage Vessels

1. NSPS OOOOb

a. Affected Facility

A storage vessel affected facility subject to the final standards is defined as a tank battery that has the potential for VOC emissions equal to or greater than 6 tpy or methane emissions equal to or greater than 20 tpy is. A storage vessel is a tank or other vessel that contains an accumulation of crude oil, condensate, intermediate hydrocarbon liquids, or produced water, and that is constructed primarily of nonferrous materials. A tank battery is a group of all storage vessels that are manifolded together for liquid transfer. For purposes of this rule, a tank battery may consist of a single storage vessel if only one storage vessel is present.

b. Final Standards

Storage vessel affected facilities must reduce emissions of VOC and methane by 95 percent. The standard reflects the degree of emission limitation achievable through application of a combustion control device or VRU, which we have identified as the BSER for storage vessel affected facilities. See rationale for the BSER at section XII.B.1.e of the November 2021 Proposal and Chapter 6 of the of the November 2021 TSD¹⁹⁴ which is unchanged in this final rule. For storage vessel affected facilities not at a well site or centralized production

¹⁹⁴ See Document ID No. EPA-HQ-OAR-2021-0317-0166.

site and without potential for flashing emissions, owners and operators may choose to comply by using an internal or external floating roof to reduce emissions in accordance with 40 CFR part 60, subpart Kb (NSPS for Volatile Organic Liquid Storage Vessels). The rule allows removal of a control device from a storage vessel affected facility if the owner or operator maintains the uncontrolled actual VOC emissions at less than 4 tpy and the actual methane emissions at less than 14 tpy as determined monthly for 12 consecutive months.

c. Cover and Closed Vent System Requirements—Control Device Requirements

Storage vessel affected facilities which use a control device to reduce emissions must equip each storage vessel in the tank battery with a cover and must equip the tank battery with one or more closed vent systems which route all emissions to a process or one or more control devices. Flares and other control devices must conduct monitoring, recordkeeping, and reporting to ensure that the control device is continuously achieving the required 95 percent reduction. More information on the flare and other control device monitoring and compliance provisions is provided in section X.H of this preamble and information regarding covers and closed vent systems may be found in section X.K of this preamble.

d. Modification and Reconstruction

The EPA finalizes as proposed the definition of modification to include specific physical changes that will trigger the modification requirements (*i.e.*, adding an additional storage vessel, replacing existing storage vessel(s) that result in an increased capacity of the tank battery, receiving additional throughput from production well(s) at tank batteries at well sites or centralized production facilities, or receiving additional fluids which cumulatively exceed the throughput used in the most recent determination of the potential for VOC or methane emissions not located at a well site or centralized production facility, including each tank battery at compressors stations or onshore natural gas processing plants that also result in exceeding the applicability threshold for either VOC or methane). The EPA defines reconstruction to mean at least half of the storage vessels are replaced in the existing tank battery that consists of more than one storage vessel, or the provisions of 40 CFR 60.15 are met for the existing tank battery and the resulting emissions exceed the

applicability threshold for either VOC or methane.

e. Legally and Practicably Enforceable (LPE) Limitations

In this action, the EPA is finalizing the proposed criteria that must be met for a permit limit or other requirement to qualify as a legally and practicably enforceable limit for purposes of determining whether a tank battery is an affected facility or designated facility under NSPS OOOOb. A legally and practicably enforceable limit must include a quantitative production limit and quantitative operational limit(s) for the equipment, or quantitative operational limits for the equipment; an averaging time period for the production limit, if a production-based limit is used, that is equal to or less than 30 days; established parametric limits for the production and/or operational limit(s), and where a control device is used to achieve an operational limit, an initial compliance demonstration (*i.e.*, performance test) for the control device that establishes the parametric limits; ongoing monitoring of the parametric limits that demonstrates continuous compliance with the production and/or operational limit(s); recordkeeping by the owner or operator that demonstrates continuous compliance with the limit(s) in; and periodic reporting that demonstrates continuous compliance.

f. Recordkeeping and Reporting Requirements

In each annual report, owners and operators are required to identify each storage vessel affected facility that was constructed, modified, or reconstructed during the reporting period and must document the emission rates of both VOC and methane individually. The annual report must include deviations that occurred during the reporting period and information for control devices tested by the manufacturer or the date and results of the control device performance test for control devices not tested by the manufacturer. The report also must include the results of inspections of covers and CVS and the identification of storage vessel affected facilities (or portion of storage vessel affected facility) removed from service or returned to service. For storage vessel affected facilities which comply with the uncontrolled 4 tpy VOC limit or 14 tpy methane limit, the report must include changes which resulted in the source no longer complying with those limits and the dates that the source began to comply with the 95 percent reduction standard. The annual report must also include information on control devices used to

achieve the 95 percent reduction standard. See section X.H of this preamble for more information related to reporting and recordkeeping for control devices.

Required records include documentation of the methane and VOC emissions determination and methodology, records of deviations and duration, records for the number of consecutive days a skid-mounted or permanently mobile-mounted storage vessel is on the site, the latitude and longitude coordinates of each storage vessel affected facility, dates that each storage vessel affected facility (or portion of storage vessel affected facility) is removed from service or returned to service, and records associated with control devices. For storage vessel affected facilities which comply with the uncontrolled 4 tpy VOC or 14 tpy methane limit, owners and operators must keep records of the monthly methane and VOC determination and methodology, records of changes which resulted in the source no longer complying with those limits, and the dates that the source began to comply with the 95 percent reduction standard. All associated records that demonstrate proper design and operation of the CVS, cover and control device also must be maintained (see section X.K and X.H of this preamble).

2. EG OOOOc

a. Designated Facility

A storage vessel is a tank or other vessel that contains an accumulation of crude oil, condensate, intermediate hydrocarbon liquids, or produced water, and that is constructed primarily of nonearthen materials. A tank battery is a group of all storage vessels that are manifolded together for liquid transfer. For purposes of EG OOOOc, a tank battery may consist of a single storage vessel if only one storage vessel is present. Each tank battery that has the potential for methane emissions greater than or equal to 20 tpy is a storage vessel designated facility.

b. Final Presumptive Standards

The presumptive methane standards in EG OOOOc for storage vessel designated facilities are the same emissions standards as those specified for methane for storage vessel affected facilities in the NSPS OOOOb final rule. Specifically, the presumptive standard is to reduce methane emissions by 95 percent. It reflects the degree of emission reduction through application of a combustion control device or VRU, which we have identified as the BSER

for storage vessel designated facilities. See rationale for the BSER at section XII.B.2. of the November 2021 Proposal and Chapter 6 of the of the November 2021 TSD¹⁹⁵ which is unchanged in this final rule. For storage vessel designated facilities not at a well site or centralized production site and without potential for flashing emissions, owners and operators could choose to comply by using an internal or external floating roof to reduce emissions in accordance with 40 CFR part 60, subpart Kb (NSPS for Volatile Organic Liquid Storage Vessels). In addition, the presumptive standards would allow removal of a control device from a storage vessel affected facility if the owner or operator maintains the uncontrolled actual VOC emissions at less than 4 tpy and the actual methane emissions at less than 14 tpy as determined monthly for 12 consecutive months. The designated facility presumptive recordkeeping and reporting requirements in the final EG OOOOc rule are also the same as those specified in the NSPS OOOOb final rule. Please see a summary of these requirements above in section X.J.1.f.

c. LPE Limitations

The EPA is finalizing the proposed criteria that must be met a permit limit or other requirement to qualify as a legally and practicably enforceable limits for purposes of determining whether a tank battery is designated facility under EG OOOOc. A legally and practicably enforceable limit must include a quantitative production limit and quantitative operational limit(s) for the equipment, or quantitative operational limits for the equipment; an averaging time period for the production limit, if a production-based limit is used, that is equal to or less than 30 days; established parametric limits for the production and/or operational limit(s), and where a control device is used to achieve an operational limit, an initial compliance demonstration (*i.e.*, performance test) for the control device that establishes the parametric limits; ongoing monitoring of the parametric limits that demonstrates continuous compliance with the production and/or operational limit(s); recordkeeping by the owner or operator that demonstrates continuous compliance with the limit(s) in; and periodic reporting that demonstrates continuous compliance. These criteria are the same as the LPE criteria for purposes of determining tank battery affected facility status finalized in NSPS OOOOb as outlined in X.J.1.e.

¹⁹⁵ See Document ID No. EPA-HQ-OAR-2021-0317-0166.

K. Covers and Closed Vent Systems

1. NSPS OOOOb

a. Compliance Assurance Requirements

This section of the preamble presents a summary of the final compliance assurance requirements for CVS and covers. As noted in section IV.K of the December 2022 Supplemental Proposal, the EPA proposed several changes to the compliance assurance requirements for CVS and covers between the November 2021 Proposal and the December 2022 Supplemental Proposal. First, the EPA proposed to align the design and operational requirements for CVS, regardless of which affected or designated facility is connected to the CVS and regardless of whether the emissions are being routed to a process or a control device. Second, the EPA proposed to allow the use of advanced methane detection technologies to demonstrate continuous compliance for CVS and covers. The use of advanced methane detection technologies to demonstrate continuous compliance for CVS and covers is discussed in section X.B of this preamble. Lastly the EPA proposed to change the emissions limit for covers and CVS from no detectable emissions (NDE) to no identifiable emissions (NIE). The EPA clarified that the proposed change was not intended to change the stringency of the standard, but to reflect the change in monitoring methods used for demonstrating compliance with the standard. NDE is a term closely linked with EPA Method 21; because the EPA proposed to allow owners and operators to demonstrate compliance with the emissions limit for covers and CVS using OGI and AVO in addition to EPA Method 21, the EPA proposed to change the terminology used in the standard from NDE to NIE. Further discussion on the NIE standard is provided below and in section XI.K.1 of this preamble. The final requirements for covers and CVS summarized below reflect the requirements that were proposed in the December 2022 Supplemental Proposal.¹⁹⁶

As in NSPS OOOO and OOOOa, NSPS OOOOb contains requirements for CVS and covers to ensure compliance with the standards for centrifugal compressor, reciprocating compressor, and storage vessel affected facilities.¹⁹⁷ CVS route emissions from well (*i.e.*, oil wells when routing associated gas to a control device), centrifugal compressor, reciprocating compressor, process

¹⁹⁶ See section IV.K, 87 FR 74804 (December 6, 2022).

¹⁹⁷ Also, as in NSPS OOOOa, CVS and covers not are not associated with an affected facility are fugitive emissions components.

controllers, pumps, storage vessels and process unit affected facilities to a control device or to a process. Each CVS must be designed and operated to capture and route all gases, vapors, and fumes to a process or to a control device and comply with an emissions limit of NIE. Covers must form a continuous impermeable barrier over the entire surface area of the liquid in the storage vessel, over the centrifugal compressor wet seal fluid degassing system, or over the reciprocating compressor rod packing emissions collection system. Each cover opening shall be secured in a closed, sealed position (*e.g.*, covered by a gasketed lid or cap) whenever material is in the unit on which the cover is installed, except during those times when it is necessary to use an opening, such as to inspect equipment or to remove material from the equipment.

Initial and continuous compliance of the NIE standard would be demonstrated through OGI or EPA Method 21 monitoring and AVO inspections conducted at the same frequency as the fugitive emissions monitoring for the type of site where the cover and CVS are located.

Alternatively, an owner or operator could demonstrate ongoing compliance with the NIE standard for covers and CVS using the periodic screening or continuous monitoring requirements for advanced methane detection technologies in 40 CFR 60.5398b, as described in section X.B of this preamble. Where AVO inspections are required, the CVS and cover is determined to operate with NIE if no emissions are detected by AVO means. Where OGI monitoring is conducted, the CVS and cover is determined to operate with NIE if no emissions are imaged by the OGI camera. Where EPA Method 21 monitoring is conducted, the CVS and cover is determined to operate with NIE if the readings obtained using EPA Method 21 are less than 500 parts per million by volume (ppmv) above background. Emissions detected by AVO, OGI, or EPA Method 21 constitute a deviation of the NIE standard until a subsequent inspection determines that the CVS and cover operates with NIE. Where monitoring is conducted using advanced methane detection technologies, covers and CVS are determined to operate with NIE if no emissions are detected by the periodic screening survey or, where continuous monitoring is conducted, the site remains under the action levels. If emissions are detected from the site during a periodic screening survey or the site exceeds an action level, the

cover and CVS are still determined to operate with NIE unless a follow-up inspection with EPA Method 21, OGI, or AVO indicates that the cover and CVS do not operate with NIE.

Each CVS must be inspected to ensure that the CVS operates with NIE initially within 30 calendar days after startup of the affected facility routing emissions through the CVS and periodically. Specifically, for the well sites and centralized production facilities where a CVS is present, quarterly OGI or EPA Method 21 and bimonthly AVO would be required; for compressor stations, quarterly OGI or EPA Method 21 and monthly AVO would be required. For CVS and covers located at onshore natural gas processing plants, AVO inspections are required annually and instrument monitoring for NIE must be conducted either bimonthly with OGI following the procedures in appendix K or quarterly in accordance with EPA Method 21. For CVS joints, seams, and connections that are permanently or semi-permanently sealed, owners and operators are not required to conduct periodic instrument monitoring with OGI or EPA Method 21, but the owner or operator must still conduct initial instrument monitoring and periodic AVO monitoring. Additionally, annual visual inspections must be conducted for all CVS to check for defects, such as cracks, holes, or gaps.

If the CVS is equipped with a bypass, the bypass must include a flow monitor and sound an alarm to alert personnel or send a notification via remote alarm to the nearest field office that a bypass is being diverted to the atmosphere, or it must be equipped with a car-seal or lock-and-key configuration to ensure the valve remains in a non-diverting position. To ensure proper design, an assessment of the closed vent system must be conducted and certified by a qualified professional engineer or in-house engineer.

Any emissions or defects detected during an inspection of a cover or CVS is subject to repair, with a first attempt at repair within 5 days after detecting the emissions or defect and final repair within 30 days after detecting the emissions or defect. While awaiting final repair, covers must have a gasket-compatible grease applied to improve the seal. Delay of repair is allowed where the repair is infeasible without a shutdown, or it is determined that immediate repair would result in emissions greater than delaying repair. In all instances, repairs must be completed by the end of the next shutdown. Owner and operators may designate parts of the CVS as unsafe to inspect and difficult to inspect but must

have a written plan of the inspection of this equipment. Equipment that is unsafe to inspect would expose inspecting personnel to an imminent potential danger; this equipment must be inspected as frequently as practicable, during safe to inspect times. Equipment that is difficult to inspect would require elevating inspecting personnel more than 2 meters above a support surface; this equipment must be inspected at least once every 5 years.

b. Recordkeeping and Reporting Requirements

The CVS certification must be submitted in the annual report in the reporting year in which the certification is signed. In each annual report, the owner or operator must report the date of each cover and CVS inspection, all defects or emissions identified during the inspections, and the date of repair or anticipated repair if the repair is delayed for each defect or emission. Owners and operators must also report the date and time of each bypass or alarm or each instance where the key is checked out. Records of CVS and cover inspections, CVS bypass monitoring, and CVS design and certifications must be maintained. The CVS certification must be submitted in the initial annual report.

Records for CVS and covers include records of inspections, CVS bypass monitoring, and CVS design and certifications. For each CVS or cover inspection, owners and operators must keep records of the date of the inspection, the method of inspection (*i.e.*, visual, AVO, OGI, or EPA Method 21), and all defects and emissions found. For each defect or emission found, the owner or operator must record the location, a description of the defect, the maximum concentration reading if EPA Method 21 is used, the date of detection, the date of each attempt to repair the defect or emission, the corrective action taken to repair the defect or emission, and the date of final repair of the defect or emission. If a repair is delayed, the owner or operator must record the reason for delay and the anticipated date of repair. Owners and operators must also keep records of unsafe and difficult to inspect portions of the CVS, including the written inspection plan. For each CVS bypass, owners and operators must keep records of readings from the flow indicator and the date and time of each instance the alarm is sounded, inspections of the seal or closure mechanism, and dates and times of each instance the key is checked out.

2. EG OOOOc

a. Compliance Assurance Requirements

The model rule in EG OOOOc includes the same covers and CVS requirements as those in NSPS OOOOb to assure that emissions from designated facilities, such as wells (*i.e.*, oil wells when routing associated gas to a control device), centrifugal compressors, reciprocating compressors, process controllers, pumps, and process unit, are captured and routed to a control device or process when such control device or process are being used to meet the presumptive standards for the designated facilities.

b. Recordkeeping and Reporting Requirements

The recordkeeping and reporting requirements for EG OOOOc are the same as those for NSPS OOOOb.

L. Equipment Leaks at Natural Gas Processing Plants

1. NSPS OOOOb

a. Affected Facility

Each process unit equipment affected facility, which is the group of all equipment within a process unit at an onshore natural gas processing plant, is an affected facility. *Equipment*, as used in the standards and requirements of this subpart relative to the process unit equipment affected facility at onshore natural gas processing plants, means each pump, pressure relief device, open-ended valve or line, valve, and flange or other connector that has the potential to emit methane or VOC and any device or system required by those same standards and requirements of this subpart. Process unit means components assembled for the extraction of natural gas liquids from field gas, the fractionation of the liquids into natural gas products, or other operations associated with the processing of natural gas products. A process unit can operate independently if supplied with sufficient feed or raw materials and sufficient storage facilities for the products.

b. Final Standards

The NSPS OOOOb final standards apply to the “process unit equipment” affected facility and require that, for each piece of equipment that has the PTE methane or VOC, owners and operators conduct bimonthly (*i.e.*, once every other month) OGI monitoring in accordance with 40 CFR part 60, appendix K¹⁹⁸ to detect equipment

¹⁹⁸ See section XIV of this preamble for information related to appendix K.

leaks from pumps in light liquid service, pressure relief devices in gas/vapor service, valves in gas/vapor or light liquid service, connectors in gas/vapor or light liquid service, and CVS. As an alternative to the bimonthly OGI monitoring, EPA Method 21 may be used to detect leaks from the same equipment at frequencies specific to the process unit equipment type (e.g., monthly for pumps, quarterly for valves). Open-ended valves and lines, pumps, valves and connectors in heavy liquid service and pressure relief devices in light liquid or heavy liquid service must be monitored using AVO. The final rule requires that when a leak is detected it must be repaired. Valves must be repaired by replacing the leaking valve with a low emission (low-E) valve, where technically feasible. The final rule also includes requirements that the leaking equipment must be tagged for identification and a first attempt at repair for all identified leaks must be commenced within 5 days after detection, with final repair completed within 15 days after detection (unless the delay-of-repair provisions are applicable). Delay of repair would be allowed where it is technically infeasible to complete repairs within 15 days without a process unit shutdown. See rationale for the BSER at section XII.H.1.c. of the November 2021 Proposal which is unchanged in this final rule.

In addition to the monitoring and repair requirements summarized previously, the final rule includes requirements for specific types of equipment. Each open-ended valve or line must be equipped with a closure device (i.e., cap, blind flange, plug, or a second valve) that seals the open end at all times except during operations which require process fluid flow through the open-ended valve or line. CVS used to comply with the standards for process unit equipment must be monitored bimonthly using OGI (or quarterly using EPA Method 21 if this alternative is used). Control devices used to comply with the equipment leak provisions must comply with the requirements described in section X.H of this preamble. Pressure relief devices must be monitored within 5 days after a pressure release to ensure the device has reseated after a pressure release. The final rule allows exceptions to the 5-day post-pressure release monitoring requirement for pressure relief devices that are located in a non-fractionating plant where the non-fractionating plant is monitored only by non-plant

personnel that are not onsite.¹⁹⁹ The exception allows the pressure relief device to be monitored after a pressure release the next time non-plant monitoring personnel are onsite, but in no event can the monitoring be delayed beyond 30 calendar days after a pressure release. Pressure relief devices that are routed to a process, fuel gas system, or control device are not required to be monitored following a release because the emissions from the release are controlled. The rule also provides exceptions to the GHG and VOC standards for process unit equipment affected facilities for certain types of equipment at a non-fractionating plant that does not have the design capacity to process 283,200 standard cubic meters per day (scmd) (10 million scf per day)²⁰⁰ or more of field gas and for equipment within a process unit at the Alaskan North Slope.

NSPS OOOOb reporting is required semiannually for process unit equipment affected facilities, which differs from the annual reporting for other affected facilities in NSPS OOOOb. In the initial semiannual report, the owner or operator must identify: each process unit associated with the process unit equipment affected facility; the number of each type of equipment subject to the monitoring requirements; for each month of the reporting period, the number of leaking equipment for which leaks were identified, the number of leaking equipment for which leaks were not repaired, and the facts that explain each delay of repair; and dates of process unit shutdowns. In subsequent semiannual reports, owners and operators must report the name of each process unit associated with the process unit equipment affected facility; any changes to the process unit identification or the number or type of equipment subject to the monitoring requirements; for each month of the reporting period, the number of leaking equipment for which leaks were

¹⁹⁹ A nonfractionating plant refers to any gas plant that does not fractionate mixed natural gas liquids into natural gas products. See 40 CFR 60.5430b and 60.5430c.

²⁰⁰ For example, for pumps in light liquid service, pressure relief devices in gas/vapor service, valves in gas/vapor and light liquid service, and connectors in gas/vapor service and in light liquid service that are located at a non-fractionating plant that do not have the design capacity to process 283,200 standard cubic meters per day (scmd) (10 million scf per day) or more of field gas, owners or operators may comply with the following exceptions: (1) They may conduct quarterly monitoring instead of bimonthly monitoring as required under § 60.5400b(b), and (2) they are exempt from the routine monitoring requirements if complying with the alternative standards of § 60.5401b.

identified, the number of leaking equipment for which leaks were not repaired, and the facts that explain each delay of repair; and dates of process unit shutdowns.

Required records in the final rule include inspection records consisting of equipment identification, date and start and end times of the monitoring inspection, inspector name, leak determination method, monitoring instrument identification, type of equipment monitored, process unit identification, appendix K records (where applicable), EPA Method 21 instrument readings and calibration results (where applicable) and, for visual inspections, the date, name of inspector and result of inspection. For each leak detected, the final rule requires recording of the instrument and operator identification (or record of AVO method, where applicable), the date the leak was detected, the date and repair method applied for first attempts at repair, indication of whether the leak is still detected, and the date of successful repair, which includes results of a resurvey to verify repair. For each delay of repair, the final rule requires that the equipment is identified as "repair delayed" along with the reason for the delay, the signature of the certifying official, and the dates of process unit shutdowns which occurred while the equipment is unrepaired. Additionally, the final rule requires records of equipment designated for NDE; the identification of valves, pumps, and connectors that are designated as unsafe-to-monitor, an explanation stating why it is unsafe-to-monitor, and the plan for monitoring that equipment; a list of identification numbers for valves that are designated as difficult-to-monitor, an explanation stating why it is difficult-to-monitor, and the schedule for monitoring each valve; a list of identification numbers for equipment that is in vacuum service and a list of identification numbers for equipment designated as having the PTE methane or VOC less than 300 hr/yr.²⁰¹

Finally, for CVS and control devices used to control emissions from process unit equipment affected facilities, the reports and records that demonstrate proper design and operation of the control device also must be maintained (see section X.H. of this preamble).

²⁰¹ This exemption is similar to that in NSPS OOOOb, which exempts owners/operators from monitoring leaks from equipment in VOC service less than 300 hr/yr. As in NSPS OOOOb, this exemption applies to equipment at onshore natural gas processing plants that is used only during emergencies, used as a backup, or that is in service only during startup and shutdown. See 85 FR 57408.

With the exception of the requirements for low-E valves, where technically feasible, these standards are unchanged from section IV.L.1 of the December 2022 Supplemental Proposal. For each valve where a leak is detected, you must comply by repacking the existing valve with a low-E packing, replacing the existing valve with a low-E valve; or performing a drill and tap repair with a low-E injectable packing. An owner or operator is not required to utilize a low-E valve or low-E packing to replace or repack a valve if the owner or operator demonstrates that a low-E valve or low-E packing is not technically feasible. Low-E valve or low-E packing that is not suitable for its intended use is considered to be technically infeasible. Factors that may be considered in determining technical infeasibility include: retrofit requirements for installation (e.g., re-piping or space limitation), commercial unavailability for valve type, or certain instrumentation assemblies.

2. EG OOOOc

a. Designated Facility

Each process unit equipment designated facility, which is the group of all equipment within a process unit at an onshore natural gas processing plant, is a designated facility. *Equipment*, as used in the standards and requirements of this subpart relative to the process unit equipment designated facility at onshore natural gas processing plants, means each pump, pressure relief device, open-ended valve or line, valve, and flange or other connector that has the potential to emit methane and any device or system required by those same standards and requirements of this subpart. *Process unit* means components assembled for the extraction of natural gas liquids from field gas, the fractionation of the liquids into natural gas products, or other operations associated with the processing of natural gas products. A process unit can operate independently if supplied with sufficient feed or raw materials and sufficient storage facilities for the products.

b. Final Standards

The EG OOOOc final methane presumptive standards for “process unit equipment” designated facilities are the same as finalized for NSPS OOOOb affected facilities. The Model Rule reporting and recordkeeping requirements are also the same as finalized for NSPS OOOOb affected facilities.

With the exception of low-E valves, these presumptive standards are

unchanged from section IV.L.2 of the December 2022 Supplemental Proposal. See rationale for the BSER at section XII.B.2 of the November 2021 Proposal which is unchanged in this final rule.

M. Sweetening Units

1. Affected Facility

A sweetening unit refers to a process device that removes H₂S and/or CO₂ from the sour natural gas stream—i.e., sweetening units convert H₂S in acid gases (i.e., H₂S and CO₂) that are separated from natural gas by a sweetening process, like amine gas treatment, into elemental sulfur in the Claus process. Each sweetening unit that processes natural gas produced from either onshore or offshore wells is an affected facility as well as each sweetening unit that processes natural gas followed by a sulfur recovery unit.

2. Final Standards

Affected facilities with a sulfur production rate of at least 5 long tons per day (LT/D) must reduce SO₂ emissions by 99.9 percent. Compliance with the standard is determined based on an initial performance test and daily reduction efficiency measurements. During the performance test, the minimum required reduction efficiency of SO₂ emissions is determined for the sweetening unit. For affected facilities that have a design capacity less than 2 LT/D of H₂S in the acid gas (expressed as sulfur), recordkeeping and reporting requirements are required. However, emissions control requirements are not required. Facilities that produce acid gas that is entirely reinjected into oil/gas-bearing strata or that is otherwise not released to the atmosphere are also not subject to emissions control requirements.

For affected facilities that use an oxidation control system, or a reduction control system followed by an incineration device, an owner or operator must (1) continually operate the oxidation/incineration device and (2) install, calibrate, maintain, and operate monitoring devices and continuous emission monitors. For affected facilities that use a reduction control system not followed by an incineration device, an owner or operator must install, calibrate, maintain, and operate a continuous monitoring system to measure the emission rate of reduced sulfur compounds.

Owners and operators of a sweetening unit device affected facility are required to submit notifications required under the NSPS General Provisions, initial and annual reports, and excess emissions

reports (as applicable). Affected facilities are also required to retain records of the following:

- (1) the applicable calculations and measurements,
- (2) an analysis demonstrating that the facility’s design capacity is less than 2 LT/D of H₂S expressed as sulfur to document exemption from the control requirements (when applicable), and
- (3) a record demonstrating that the facility’s design capacity is less than 150 LT/D of H₂S expressed as sulfur (if electing to comply with 40 CFR 60.5407b(e)).

This is unchanged from section IV.M of the December 2022 Supplemental Proposal.

N. Electronic Reporting

To increase the ease and efficiency of data submittal and data accessibility, the EPA is finalizing, as proposed, a requirement that owners and operators submit electronic copies of performance test reports, natural gas processing plant semiannual reports, annual reports, and notifications of well closure activities through the EPA’s Central Data Exchange (CDX) using the Compliance and Emissions Data Reporting Interface (CEDRI). A description of the electronic data submission process is provided in the memorandum, *Electronic Reporting Requirements for New Source Performance Standards (NSPS) and National Emission Standards for Hazardous Air Pollutants (NESHAP) Rules*, available in the docket for this action. The final rulemaking requires that performance test results be submitted in the format generated through the use of the ERT or an electronic file consistent with the xml schema on the ERT website. For natural gas processing plant semiannual reports and annual reports, the final rule requires that owners and operators use the appropriate spreadsheet template to submit information to CEDRI. The final version of the templates for these reports will be located on the CEDRI website.²⁰² The final rulemaking requires that notifications of well closure activities be submitted as a portable document format (PDF) upload in CEDRI. The EPA is also finalizing, as proposed, these same requirements in EG OOOOc.

Furthermore, the EPA is finalizing in NSPS OOOOb and EG OOOOc, as proposed, provisions that allow owners and operators the ability to seek extensions for submitting electronic reports for circumstances beyond the control of the facility, i.e., for a possible

²⁰² <https://www.epa.gov/electronic-reporting-air-emissions/cedri>.

outage in CDX or CEDRI or for a *force majeure* event, in the time just prior to a report's due date, as well as the process to assert such a claim.

O. Prevention of Significant Deterioration and Title V Permitting

The pollutants subject to regulation in this final rulemaking are VOC and GHGs (which are regulated in this rule in the form of methane limitations). As explained in section XV of this preamble, we are finalizing provisions to NSPS OOOOb and EG OOOOc, analogous to what was included in the 2016 NSPS OOOOa and other rules regulating GHGs from electric utility generating units, to address some of the potential implications this final rulemaking could have on the CAA Prevention of Significant Deterioration (PSD) preconstruction permit program and the CAA title V operating permit program.

XI. Significant Comments and Changes Since Supplemental Proposal for NSPS OOOOb and EG OOOOc

This section of the preamble presents in each subsection a summary of any changes since the December 2022 Supplemental Proposal for the topic being addressed in that subsection, as well as significant comments on that topic and the EPA's response thereto. For final NSPS standards and requirements and final EG presumptive standards and requirements that have not changed since the December 2022 Supplemental Proposal, the supporting rationales for the EPA's BSER determinations are not reiterated in this preamble. The rationale for these standards and requirements can be found in the preamble to the December 2022 Supplemental Proposal and in the TSD for the December 2022 Supplemental Proposal. The EPA's full response to comments on the November 2021 Proposal and December 2022 Supplemental Proposal, including any comments not discussed in this preamble, can be found in the EPA's RTC document for the final rule.²⁰³

²⁰³ *Standards of Performance for New, Reconstructed, and Modified Sources and Emissions Guidelines for Existing Sources: Oil and Natural Gas Sector Climate Review. Response to Public Comments on the November 2021 Proposed Rule and the December 2022 Supplemental Proposed Rule* (86 FR 63110, November 15, 2021; 87 FR 74702, December 6, 2022).

A. Fugitive Emissions From Well Sites, Centralized Production Facilities, and Compressor Stations

1. Fugitive emissions at Well Sites and Centralized Production Facilities

In section X.A.1 of this document, the final NSPS OOOOb and EG OOOOc requirements for fugitive emissions components at well sites and centralized production facilities are summarized. The BSER analysis for fugitive emissions components at well sites and centralized production facilities is unchanged from what was presented in the December 2022 Supplemental Proposal (see 87 FR 74729–39, section IV.A.1: Fugitive Emissions at Well Sites and Centralized Production Facilities). Significant comments were received on the December 2022 Supplemental Proposal on the following topics: (1) the definition of fugitive emissions component, (2) the EPA's assumption regarding the effectiveness of OGI and AVO, (3) the order of evaluating AVO in the BSER analysis, (4) subcategorization of well sites, and (5) miscellaneous other changes. For each of these topics, a summary of the proposed rule (where relevant), the comments, the EPA responses, and changes made in the final rule (if applicable), are discussed here. These comments and the EPA's responses to these comments generally apply to the standards proposed in both the NSPS OOOOb and EG OOOOc. The instances where the comment and/or response only applies to the NSPS OOOOb or EG OOOOc are noted. The EPA's full response to comments on the November 2021 Proposal and December 2022 Supplemental Proposal, including any comments not discussed in this preamble, can be found in the EPA's RTC document for the final rule.²⁰⁴ This section of this document presents a summary of significant comments received on fugitive emissions components affected or designated facilities located at well sites and centralized production facilities and the EPA's response to those comments, as well as changes the EPA has made to the well site fugitive emissions requirements of NSPS OOOOb and EG OOOOc since the December 2022 Supplemental Proposal.

²⁰⁴ *Standards of Performance for New, Reconstructed, and Modified Sources and Emissions Guidelines for Existing Sources: Oil and Natural Gas Sector Climate Review. Response to Public Comments on the November 2021 Proposed Rule and the December 2022 Supplemental Proposed Rule* (86 FR 63110, November 15, 2021; 87 FR 74702, December 6, 2022).

a. Fugitive emissions component definition

Comment: Commenters suggested various revisions to the proposed definition of fugitive emissions components. A commenter²⁰⁵ asked that the EPA exclude yard piping from the definition because this inclusion would expand the definition in an unprecedented way. According to the commenter, cracks and holes in piping have never been considered fugitive components in any other rule for LDAR in any industry sector by the Agency. The commenter asserted that the EPA has not explained how leak detection should be conducted for yard piping, as compared to other fugitive emissions components where there are identifiable leak points (such as valve stems or flange interfaces) that are the target of monitoring. The commenter also noted that cracks and holes represent potential loss of containment and are already repaired and corrected per industry practice and code. Another commenter²⁰⁶ asked that the EPA exclude buried yard piping from the definition of fugitive emissions components because buried components are difficult or impossible to monitor.

Another commenter²⁰⁷ supported the EPA's inclusion of yard piping in the definition. This same commenter asked that the EPA also include certain equipment types like separators in the definition so monitoring of separator dump valves and components on all other equipment would clearly be required. The commenter noted that separator dump valves are a known source of large fugitive emissions events. In response to the November 2021 Proposal, the commenter²⁰⁸ had made a similar case for inclusion of separator dump valves in the definition in order to ensure that these components are monitored.

Response: In the final NSPS OOOOb and EG OOOOc rules, the EPA has retained yard piping²⁰⁹ in the definition of fugitive emissions components. A definition of yard piping was added for clarity. As discussed in the December 2022 Supplemental Proposal, pipes can experience cracks or holes, which can lead to fugitive emissions. The inclusion of yard piping in the definition of fugitive emissions components will help ensure that fugitive emissions from

²⁰⁵ EPA-HQ-OAR-2021-0317-2428.

²⁰⁶ EPA-HQ-OAR-2021-0317-2326.

²⁰⁷ EPA-HQ-OAR-2021-0317-2433.

²⁰⁸ EPA-HQ-OAR-2021-0317-0844.

²⁰⁹ The EPA recognizes that the terms "yard piping" and "in yard piping" were used interchangeably in the December 2022 Supplemental Proposal. The final rule uses the term "yard piping" consistently.

these sources do not go undetected during fugitive emissions monitoring and that issues found from the pipe itself leading to the fugitive emissions are addressed. If industry is already conducting checks for leaks as standard practice and code, this would further assist in ensuring that fugitive emissions are minimized. AVO and OGI can be used to detect fugitive emissions from cracks and other defects in yard piping by scanning along the length of the piping. However, the EPA acknowledges that EPA Method 21 does not include instructions for monitoring yard piping; therefore, the EPA is providing directions in this final rule on how to monitor yard piping while conducting an EPA Method 21 monitoring survey. Lastly, the EPA recognizes the difficulty of monitoring yard piping that is buried, as it may require disturbing the surface, which could inadvertently cause emissions; therefore, the final NSPS OOOOb and EG OOOOc rules only require monitoring of yard piping and associated fugitive components (e.g., connectors) that are at or above ground level.

Regarding a commenter's request that the definition of fugitive emissions components explicitly include separators, the EPA agrees that, although the list of components in the definition is not exhaustive, it is worthwhile to eliminate any ambiguity as to whether separator dump valves are fugitive emissions components. The EPA is finalizing a definition of fugitive emissions components in NSPS OOOOb and EG OOOOc that specifically includes separator dump valves, thus clarifying that the separator dump valve is subject to monitoring by OGI, AVO, or other detection methods. In addition, because malfunctioning separator dump valves are a known source of large emissions (as the commenter noted) and because sometimes there is visual evidence of the malfunction, the EPA is requiring in the final rule that, during the regular AVO monitoring surveys (either quarterly or bimonthly depending on the site), a visual inspection must be conducted of all separator dump valves to ensure that they are free of debris and not stuck in an open position, and any dump valve not operating as designed must be repaired.

b. OGI and AVO Effectiveness

Comment: Some commenters claimed that the EPA's assumptions for OGI and AVO effectiveness in both NSPS OOOOb and EG OOOOc are overstated and need to be adjusted. Specifically, these commenters were concerned the upper bound assumption of the

percentage of leaks that will be detected by either method should be adjusted to reflect that these methods will not find all leaks during a survey. These commenters suggested that not all leaks, even large ones, would be observed during the monitoring survey, so not all the leaks would be repaired.

One commenter²¹⁰ specifically objected to the EPA's reliance on emissions information from the 2021 Rutherford, *et al.*, study²¹¹ because the commenter believes the study "cherry-picks" data. This same commenter believes that the EPA ignores relevant information from the U.S. DOE marginal well study²¹² and urged the use of DOE emissions data in FEAST modeling to evaluate programs for low production and existing sites.

Conversely, one commenter²¹³ asserted that the EPA's assumptions about the effectiveness of OGI are supported by recent data and FEAST modeling. One commenter²¹⁴ believes that all inputs used by the EPA are reasonable, are appropriate, and ensure that advanced technologies deliver emissions reductions commensurate with OGI across diverse basins.

Other commenters²¹⁵ expressed overall support of the use of FEAST modeling and recommended some adjustments. One commenter²¹⁶ noted that intermittency of emissions should be represented in modeling. As it specifically relates to AVO, one commenter²¹⁷ indicated that there is limited availability of information and studies on the effectiveness of AVO inspections for emissions with variable rates, intermittent emissions, emissions elevated above ground level, [varying] emission point aperture sizes, and emissions occurring in varying ambient conditions (e.g., wind, rain, and other ambient equipment/process/compressor noise that may obstruct detection). The commenter recommended that the EPA perform or seek out studies of AVO effectiveness across this range of conditions before incorporating it into the FEAST model for calculation of emissions reductions for purposes of

equivalency demonstration for alternative monitoring solutions. Another commenter²¹⁸ noted that leak detection and repair data collected in Colorado show both different annual rates for leaks requiring repair as well as few leaks requiring repair as detected by AVO.²¹⁹

Response: As discussed in the December 2022 Supplemental Proposal preamble and noted by the commenters, the revised approach for estimating the fugitive emissions under different monitoring scenarios at well sites uses a FEAST modeling approach based on the presence of specific types of equipment at well sites. The modeling uses built-in emissions data from various emissions measurement campaigns which were supplemented with additional study data to provide an empirical emissions dataset for the model simulations. The EPA used the FEAST model to evaluate potential fugitive emissions monitoring and repair programs at well sites (87 FR 74725). The effectiveness of fugitive emissions monitoring and repair programs are simulated within the FEAST model based on the probability of detection (PoD) curves (or surfaces) for each monitoring method and frequency, which indicate the probability that a leak of a given size will be detected within a given survey. Survey times (frequencies) are accounted for as finite time periods. The model quantifies emissions occurring at a site over a period of time (e.g., we used a 5-year simulation and evaluated the emissions in the fifth year of the simulation), accounting for simulated leak generation, identification, and repair rates. Emissions reductions are calculated by comparing the simulated fugitive emissions program against a baseline scenario where no program is implemented.

The emissions data used in the FEAST model included data from direct measurement campaigns. Despite some shortcomings of the data in studies analyzed in the Rutherford, *et al.*, study, the study is useful because it analyzes and reconciles multiple sources of data and multiple methods of estimating emissions to arrive at a more robust and validated model of component-level emissions from well sites. The EPA chose to use the Rutherford, *et al.*, study and the U.S. DOE marginal well study to help inform assumptions necessary to establish a baseline emissions scenario

²¹⁰ EPA-HQ-OAR-2021-0317-2446.

²¹¹ Rutherford, J.S., Sherwin, E.D., Ravikumar, A.P., *et al.* "Closing the methane gap in U.S. oil and natural gas production emissions inventories." *Nat Commun* 12, 4715 (2021). <https://doi.org/10.1038/s41467-021-25017-4>.

²¹² Bowers, Richard L. "Quantification of Methane Emissions from Marginal (Low Production Rate) Oil and Natural Gas Wells." <https://doi.org/10.2172/1865859>.

²¹³ EPA-HQ-OAR-2021-0317-2433.

²¹⁴ EPA-HQ-OAR-2021-0317-2433.

²¹⁵ EPA-HQ-OAR-2021-0317-2286, -2433, -2446.

²¹⁶ EPA-HQ-OAR-2021-0317-2387.

²¹⁷ EPA-HQ-OAR-2021-0317-2333.

²¹⁸ EPA-HQ-OAR-2021-0317-2286.

²¹⁹ Commenter refers to Colorado's 2021 LDAR Annual Report; e.g., in 2021, only 1,546 leaks were detected during 564,427 AVO inspections (<https://cdphe.colorado.gov/oiland-gas-and-your-health/oil-gas-compliance-and-recordkeeping>).

in the FEAST model because they represent credible compilations of relevant emissions data at the well site level. The set-up of the FEAST model was further validated by finding that the results generated by FEAST regarding the effectiveness of different OGI monitoring frequencies align well with other values reported in literature. The EPA found that the FEAST results align with the EPA's historical assumptions of 40, 60, and 80 percent, for annual, semiannual, and quarterly OGI monitoring, respectively,²²⁰ and these percent efficiencies compare well to those discussed in the TSD for the 2020 Technical Rule.²²¹

For the December 2022 Supplemental Proposal, the FEAST modeling conducted generally assumed a 100 percent probability of OGI camera operators' seeing all leaks above a certain size threshold. Following the December 2022 Supplemental Proposal, the EPA investigated the effect of lowering the probability of detection, based on public comments received asserting that not all leaks would necessarily be detected (and subsequently lower emissions reductions would be achieved). The EPA modeled ground-based surveys with maximum probability of detection of 70, 90, and 100 percent detection limits. A complete discussion of the EPA's assessment of the maximum probability of detection is presented in a memorandum²²² available in the rulemaking docket. The results of this additional modeling suggest that lowering the maximum probability of detection would not appreciably change either the control effectiveness of various fugitive emissions monitoring and repair programs or the conclusion regarding the cost-effective monitoring programs.²²³ Therefore, the EPA

²²⁰ Specifically, for large well sites at a 0.5 percent leak generation rate, FEAST estimates reductions of 47, 67, and 78 percent, for annual, semiannual, and quarterly monitoring, respectively. For multi-wellhead only well sites at a 0.5 percent leak generation rate, FEAST estimates reductions of 44, 67, and 78 percent, for annual, semiannual, and quarterly monitoring, respectively. For single wellhead only well sites, FEAST estimates reductions of 48, 68, and 77 percent, for annual, semiannual, and quarterly monitoring, respectively.

²²¹ See section 2.4.1 of "Oil and Natural Gas Sector: Emission Standards for New, Reconstructed, and Modified Sources Background Technical Support Document for the Final Reconsideration of the New Source Performance Standards 40 CFR part 60, subpart OOOOa." August 2020. EPA-HQ-OAR-2017-0483-2290.

²²² Memorandum from Jeff Coburn, RTI International. *Summary of Additional FEAST Modeling Runs*. September 25, 2023.

²²³ As observed in this analysis, cost-effective monitoring frequencies when using a lower maximum probability of detection would be at least as frequent when assuming a 100 percent maximum probability of detection for large leaks. *Id.*

maintains that the OGI percent reduction efficiencies obtained via the FEAST modeling that was conducted for the December 2022 Supplemental Proposal (see tables 11–13 of the December 2022 Supplemental Proposal (87 FR 74732–34), which align with previous assumptions and existing literature, are representative.

With respect to AVO effectiveness, the EPA did use an upper level of detection of 90 percent for AVO monitoring. The EPA acknowledges that the level of detection for AVO will be more variable than for OGI because leaks detected by olfactory methods (smell) will largely rely on other constituents present in the natural gas. However, the modeling runs when using AVO alone provided reasonable agreement with the emissions from oil and gas production sites that rely primarily on AVO inspections as reported in the U.S. DOE marginal well study data.²²⁴ Therefore, the EPA concluded that the modeling assumptions regarding the effectiveness of AVO monitoring were reasonable.

With respect to the recommendation to include intermittent emissions events in the FEAST model, the EPA has not done so for the following reasons. First, in order to model intermittent emissions events, assumptions would have to be made regarding the fraction of fugitive emissions that exhibit intermittent behavior and the typical duration of active emissions and of periods of low or zero emissions. Because the EPA has limited data from which to make these necessary assumptions, to include intermittent emissions events in the model would introduce great uncertainty to the model. Second, the EPA notes that intermittent emissions events are largely reported with respect to "super-emitters," which the EPA is addressing through the Super Emitter Program established in this final rule.²²⁵ For the reasons stated, the EPA has not included intermittent emissions events in the model.

c. Order of AVO evaluation in the BSER

Comment: One commenter²²⁶ believes that the EPA should have developed its regulatory strategy by first evaluating AVO and determining its cost effectiveness; then, the EPA should have assessed the impact of adding OGI monitoring. The commenter believes that evaluating whether additional OGI monitoring is appropriate and at what

²²⁴ Memorandum from Jeff Coburn, RTI International. *Summary of Additional FEAST Modeling Runs*. September 25, 2023.

²²⁵ See sections X.C and X.I for details on the Super Emitter Program.

²²⁶ EPA-HQ-OAR-2021-0317-2446.

frequency should have come after the evaluation of AVO inspection in the EPA's BSER analysis for NSPS OOOOb and EG OOOOc. According to the commenter, this is particularly relevant for multi-wellhead only well sites (where the proposed requirement was semiannual OGI and quarterly AVO) as the EPA acknowledged that large leaks from a wellhead could be detected with AVO. Commenters claimed that the EPA did not provide adequate justification as to why having two or more wellheads requires the use of OGI. Industry commenters believe that the NSPS OOOOb and EG OOOOc BSER for multi-wellhead only sites should be quarterly AVO inspections only (bimonthly AVO inspections only at most). Another commenter²²⁷ similarly expressed that using AVO inspections to find large fugitive emissions at single wellhead only sites is appropriate and should also apply to multi-wellhead only well sites. Quarterly AVO inspections are appropriate to detect fugitive emissions at multi-wellhead only well sites, according to the commenter. A commenter²²⁸ stated that wellhead only sites generally have fewer fugitive emissions components, and wellheads are constructed with thicker, higher-pressure-rated iron, causing flanges to be larger such that AVO inspections are able to reliably detect any leaks that may occur. The commenter believed quarterly AVO inspection of wellhead only sites would be an effective and economic means to monitor for leaks at wellhead only sites. Another commenter²²⁹ expressed support for AVO for these sites but did not support OGI, due to its cost and because the incremental benefit of using OGI on top of AVO would not meaningfully reduce emissions.

Response: The EPA disagrees with the comment that it should have first evaluated AVO and determined its cost effectiveness and then assessed whether to add OGI monitoring for multi-wellhead only well sites and well sites with major production and processing equipment.²³⁰ While OGI's superiority

²²⁷ EPA-HQ-OAR-2021-0317-2428.

²²⁸ EPA-HQ-OAR-2021-0317-2326.

²²⁹ EPA-HQ-OAR-2021-0317-2202.

²³⁰ As explained in the December 2022 Supplemental Proposal and reiterated later in this response, the EPA did not propose OGI monitoring for single wellhead only well sites based on information showing that these emissions are large releases that can be detected using AVO (87 FR 74729). Similarly, the EPA did not propose OGI monitoring for a small wellsite; the EPA utilized the same model results as provided for a single wellhead only well site (87 FR 74731). As defined, a small well site can only include one piece of certain major production and processing equipment, which cannot be a controlled storage

over AVO is clear, the EPA nevertheless offered a detailed explanation in the December 2022 Supplemental Proposal (87 FR 74727). As the EPA explained, AVO is a simple sensory method that can detect large releases such as emissions from open thief hatches; however, not all fugitive emissions components have large releases and, therefore, their emissions cannot always be detected by AVO. AVO's reliability also depends on other factors, including whether the background noise is sufficiently low to allow a person to hear leaks such as the hissing sound from a high-pressure leak, whether the gas is of a mixture that would allow detection by smell, or whether the leaks result in dripping or puddles that can be detected visually. In contrast, OGI can reliably detect fugitive emissions that AVO cannot. Therefore, in the November 2021 Proposal, the EPA proposed monitoring fugitive emissions using OGI at well sites with baseline emissions at or greater than 3 tpy and no monitoring for those with baseline emissions below that level; the EPA solicited comment on "simple AVO checks that could be performed in conjunction with the periodic OGI monitoring surveys to help identify potential large emission events" (86 FR 63197). In the December 2022 Supplemental Proposal, the EPA proposed four subcategories of well sites and monitoring regime for each subcategory based on numbers and types of equipment. For example, single wellhead only well sites have few pieces of simple equipment and therefore few fugitive emissions components,²³¹ but they have been found to have large emissions that result from fugitive emissions components, such as an open valve on a well case casing; because the number of components is small and the large releases could be detected with AVO, OGI monitoring does not seem necessary at a single wellhead only well site.²³² That is not the case with multi-wellhead only well sites, which are the focus of the comments summarized above. As the number of wellheads increases, so does the number of fugitive emissions components, including those associated with smaller emissions that are difficult to detect with AVO; however, OGI can detect fugitive

vessel, a control device, or a natural gas-driven process controller or pump (*Ibid.*). As such, the equipment and associated fugitive emissions components at a small site are more comparable to a single wellhead only well site than to the other two subcategories of well sites (see *Id.* at 74726, table 7).

²³¹ See *Id.* at 74726, table 7.

²³² *Id.* at 74727.

emissions from those components in addition to the large releases. Accordingly, in the December 2022 Supplemental Proposal, the EPA proposed adding AVO monitoring to routine OGI monitoring requirements in order to identify large emissions that could occur in between scheduled OGI surveys at multi-wellhead only well sites and well sites with major production and processing equipment (see 87 FR 74722).

As discussed in the December 2022 Supplemental Proposal, multi-wellhead only well sites feature both large emission sources that can be identified with AVO as well as additional, generally smaller sources of emissions that are more challenging to identify using AVO. In order to capture both large and small emissions from multi-wellhead only well sites, the EPA proposed semiannual OGI monitoring and quarterly AVO surveys for NSPS OOOOb and EG OOOOc. The EPA agrees with commenters that periodic AVO surveys are less costly than OGI surveys. However, cost is not the only factor in determining the BSER, and other considerations, such as effectiveness at reducing emissions from both large and small releases, must be considered. As part of its BSER analysis for reducing fugitive emissions at well sites, the EPA analyzed the costs and emission reductions associated with various combinations of OGI and AVO monitoring options for the four categories of well sites. The EPA summarized its analysis for multi-wellhead only well sites in table 12 and explained how it evaluated the various options (see 87 FR 74733, table 12). The EPA found semiannual OGI and quarterly AVO to be cost-effective and therefore to be the BSER for multi-wellhead only well sites.

d. Subcategorization of Well Sites

Comment: Several commenters requested that the EPA consider maintaining an exemption for low production wells as it pertains to the NSPS OOOOb and EG OOOOc. These commenters noted that industry has consistently advocated for such an exemption in previous rulemakings. Commenters also asserted that exempting low production wells would provide meaningful reductions in compliance burden and cost for small businesses, with minimal potential impact. Commenters²³³ argued that the proposed monitoring requirements and schedule are excessive for these sites, provide little environmental benefit,

²³³ EPA-HQ-OAR-2021-0317-2179, -2248, -2310, -2713.

and are prohibitive for small owners and operators and will result in the end of their operations. One commenter²³⁴ noted that the U.S. DOE marginal well study provides data showing that marginal well sites overwhelmingly have methane emissions below 3 tpy. One commenter²³⁵ urged the EPA to modify the rule to include a production rate threshold that would exempt wells making less than 6 boe per day. One commenter²³⁶ recommended that the EPA create an intermediate well site category that combines production throughput and components, opining that this would be a simpler approach that avoids inappropriate results. According to the commenter, under the current proposal, some low-producing sites would be classified as large sites and be subject to quarterly OGI monitoring with bimonthly AVO inspections. The commenter asserted that the data from the U.S. DOE marginal well study shows that this category of sites has lower total emissions than sites with larger production volumes and therefore should not be subject to monitoring requirements as stringent as those for larger-producing sites. The commenter proposed that intermediate well sites historically considered to be "low production" be permitted to utilize industry practices to identify leaks. The commenter asserted that the EPA's proposal places an economic burden on owners/operators of low production wells that is not justified or supported.

Response: Following the December 2022 Supplemental Proposal, the EPA received the underlying dataset for the U.S. DOE marginal well study, which was previously not available, and the EPA further evaluated the methane emissions data obtained during the field campaigns of the U.S. DOE marginal well study. Specifically, in response to comments that the EPA should have incorporated the DOE emissions dataset into the FEAST modeling because the baseline emissions estimated by the EPA were overstated and that lower baseline emissions should be used, the EPA added U.S. DOE marginal well study data to the previous FEAST model simulations to evaluate whether this was the case.

The EPA also evaluated how the leaks measured in the U.S. DOE marginal well study compared with the leaks measured in the other studies included in the FEAST model as used to support the supplemental proposal. The EPA determined that the U.S. DOE marginal

²³⁴ EPA-HQ-OAR-2021-0317-2403.

²³⁵ EPA-HQ-OAR-2021-0317-2179.

²³⁶ EPA-HQ-OAR-2021-0317-2446.

well study data agrees well with the emissions data included in FEAST as modeled for the December 2022 Supplemental Proposal when comparing the different equipment component leak data used. The EPA also ran several individual monitoring options using the equipment component data from the December 2022 Supplemental Proposal, using the component data from the December 2022 Supplemental Proposal augmented with U.S. DOE marginal well study data, and also using only the U.S. DOE marginal well study data. The FEAST model was run using these three sets of equipment component leak input data for multi-wellhead only well sites. The results demonstrated that varying the specific equipment component leak input data had minimal impact on the model results, and the FEAST model simulation results did not vary significantly when U.S. DOE marginal well study data was included. The full results of the additional FEAST modeling the EPA performed following the December 2022 Supplemental Proposal are presented in a memorandum²³⁷ available in the rulemaking docket. In conclusion, the addition of U.S. DOE marginal well study data did not show results that are significantly different than what the EPA presented in the December 2022 Supplemental Proposal.

Moreover, the U.S. DOE marginal well study concludes that the frequency and magnitude of emissions from well sites are more strongly correlated with equipment counts than with production rates. See the EPA's response in section XII.A for additional details and data.

The EPA therefore does not have compelling information that suggests low production levels at well sites should provide the basis for adding a new subcategory to the fugitive emissions requirements.

Many factors can affect the profitability of marginal wells and the decision to shut in and plug a well, making it difficult to determine the full impact of regulation on the financial status of marginal well owners, as discussed in chapter 6 of the final rule TSD. While the EPA does not have data on the distribution of ownership based on firm size, there are small owners and operators who own marginal oil and natural gas wells. The EPA remains mindful of how the fugitive emissions monitoring requirements will affect small entities and describes steps taken to include regulatory flexibility and

streamline recordkeeping requirements in section 4.4 of the RIA. While developing the fugitive emissions monitoring program, the EPA limited monitoring, recordkeeping, and reporting requirements to include only what is necessary to meet BSER and demonstrate compliance. These streamlined requirements benefit owners and operators of well sites (including small entities).

e. Delay of Repair Due to Parts Unavailability

Comment: A commenter²³⁸ noted that NSPS OOOO and OOOOa allow for delay of repair beyond a unit shutdown if "valve assembly supplies have been depleted, and valve assembly supplies had been sufficiently stocked before the supplies were depleted." The commenter notes that in the November 2021 Proposal (86 FR 63174), the EPA recognized that operators of older equipment may experience delays in obtaining replacement parts. Given current supply chain issues and the larger number of well sites, centralized production facilities, and compressor stations, the EPA should expand the current delay-of-repair requirements to include delays because of parts unavailability.

Response: Based on this comment and those summarized later in section XI.A.2.b on compressor stations, the EPA is allowing delay of repair of fugitive emissions components due to unavailability of replacement components (or parts thereof) in certain circumstances at well sites, centralized production facilities, and compressor stations. Specifically, delay of repair is allowed if replacement is required but cannot be acquired and installed within the repair timeline due to either of the following conditions: (1) replacement valve supplies have been sufficiently stocked but are depleted at the time of repair; or (2) a replacement fugitive emissions component or a part thereof requires custom fabrication. See section XI.A.2.b for our reasons for allowing delay of repair under these specified conditions, our response to the major comments on this issue, and additional details on this provision.

f. Other Changes

The EPA has made certain corrections to the regulatory text of NSPS OOOOb and EG OOOOc since the December 2022 Supplemental Proposal.

The EPA is correcting the definition of "major production and processing equipment" to add certain equipment that were inadvertently excluded in the

December 2022 Supplemental Proposal. In the preamble to the December 2022 Supplemental Proposal, the EPA specifically proposed to identify natural gas-driven pneumatic controllers, natural gas-driven pneumatic pumps, and control devices as "major production and processing equipment" in the context of defining well site subcategories for the fugitive emissions monitoring and repair program of NSPS OOOOb and EG OOOOc and justifying requiring quarterly OGI monitoring where this equipment is present (87 FR 74723 and 74735). Following the publication of the December 2022 Supplemental Proposal, the EPA noticed that the draft regulatory text for NSPS OOOOb and EG OOOOc accompanying the proposal would have inadvertently adopted, without change, the definition of "major production and processing equipment" in NSPS OOOOa, which has a different fugitive emissions monitoring program for well sites than that of NSPS OOOOb and EG OOOOc; as a result, natural gas-driven pneumatic controllers, natural gas-driven pneumatic pumps, and control devices were inadvertently excluded from the definition of "major production and processing equipment" in the proposed NSPS OOOOb and EG OOOOc. The following edits were made to align the regulatory text with the EPA's intent as stated in the Supplemental Proposal:

- Added "natural gas-driven pumps" to the list of major equipment that puts a well site into the third subcategory (well sites with major production and processing equipment or centralized production facilities) at 40 CFR 60.5397b(g)(1)(iv)(C) and 40 CFR 60.5397c(g)(1)(iii)(C);
- Added "natural gas-driven pumps" to the list of major equipment that cannot be present at a small well site at 40 CFR 60.5430b and 40 CFR 60.5430c; and
- Added "control devices, natural gas-driven process controllers, natural gas-driven pumps" and "tank batteries" to the definition of major production and processing equipment at 40 CFR 60.5430b and 40 CFR 60.5430c.

Similarly, in the December 2022 Supplemental Proposal, the EPA proposed as part of the fugitive emissions standards and presumptive standards an equipment standard such that thief hatches and other openings on a storage vessel that are fugitive emissions components must remain closed and sealed at all times except during sampling, adding process material, or attended maintenance operations (87 FR 74731). However, this proposal was not reflected in the

²³⁷ Memorandum from Jeff Coburn, RTI International. *Summary of Additional FEAST Modeling Runs*. September 25, 2023.

²³⁸ EPA-HQ-OAR-2021-0317-2428.

regulatory text accompanying the December 2022 Supplemental Proposal. The EPA is finalizing this requirement, which has been added to the regulatory text (see 40 CFR 60.5397b(g)(1)(ii) and (iv) and 40 CFR 60.5397c(g)(1)(i) and (iii)).

Lastly, the EPA added to the final rules definitions of single wellhead only well sites and multi-wellhead only well sites at 40 CFR 60.5430b and 40 CFR 60.5430c to avoid confusion.

2. Fugitive Emissions at Compressor Stations

In section X.A.2 of this document, the final NSPS OOOOb and EG OOOOc requirements for fugitive emissions components at compressor stations are summarized. The BSER analysis for fugitive emissions components at compressor stations is unchanged from what was presented in the December 2022 Supplemental Proposal (see 87 FR 74739–40, section IV.A.2: OGI Monitoring at Compressor Stations). In the December 2022 Supplemental Proposal, the EPA proposed the BSER as monthly AVO combined with quarterly OGI (or EPA Method 21) monitoring requirements for fugitive emissions components affected facilities located at compressor stations, which would take the form of a work practice standard. However, significant comments were received on the December 2022 Supplemental Proposal on the following topics: (1) the monthly AVO monitoring requirement and (2) delay of repair for parts unavailability. Comments on these topics and the EPA's responses are discussed here. These comments and the EPA's responses to these comments generally apply to the standards proposed in both the NSPS OOOOb and EG OOOOc. The EPA's full response to comments on the November 2021 Proposal and December 2022 Supplemental Proposal, including any comments not discussed in this preamble, can be found in the EPA's RTC document for the final rule.²³⁹

a. Monthly AVO Monitoring

Comment: Some commenters claim that the monthly AVO requirement for compressor stations is unnecessary. One commenter²⁴⁰ indicated that to require monthly AVO and quarterly OGI or EPA Method 21 monitoring and

recordkeeping is overly burdensome and unnecessary for compressor stations. This commenter believes that existing equipment and monitoring methods have proven effective and have minimized emissions, and believes a baseline threshold for low-volume compressor stations and periodic AVO inspections and documentation would effectively achieve the goals of the proposed requirements. Another commenter²⁴¹ argued that, compared to state-of-the-art continuous monitoring systems, the proposed requirement for monthly AVO inspections and quarterly OGI inspections provides neither the greatest emissions reduction nor the most economical solution. This commenter encouraged the EPA to also allow continuous monitoring technology solutions as the BSER for compressor stations. On the other hand, a commenter²⁴² recommended that monthly AVO inspections in addition to quarterly instrument-based leak detection and repair inspections should be required at gathering and boosting and transmission stations.

Response: For the reasons explained here, the EPA found unpersuasive those comments suggesting that the proposed fugitive emissions monitoring requirements at compressor stations, in particular monthly AVO inspections, are unnecessary or burdensome. As explained in the December 2022 Supplemental Proposal (87 FR 74739), regular AVO inspections at compressor stations can be conducted by any staff at the site without the need for any special expertise. In fact, AVO inspection was added in the December 2022 Supplemental Proposal in response to recommendations by some commenters^{243 244} on the November 2021 Proposal recommending AVO as a low-cost method that is effective at identifying emissions, even for small-company compressor stations. The commenters specifically noted that even though small-company compressor stations are not manned 24 hours per day, they are visited weekly, if not daily. The EPA found the comments persuasive and did not see a need to confirm the commenters' assertions by conducting its own cost analysis for conducting monthly AVO inspections for compressor stations. The EPA notes that no commenter disputed or otherwise questioned the comments described above regarding the low cost of AVO monitoring, which the EPA relied upon in its December 2022

Supplemental Proposal. With regard to the comment suggesting that OGI monitoring is unnecessary because AVO surveys during these frequent visits would effectively achieve the EPA's emission reduction goals, the EPA disagrees that AVO surveys alone (*i.e.*, without quarterly OGI monitoring) qualify as the BSER because OGI is needed to detect fugitive emissions that are not detectable by AVO. In addition, the EPA received no information that caused it to change its assessment that quarterly OGI monitoring at compressor stations is not cost-effective.

Accordingly, the EPA is finalizing its determination that monthly AVO monitoring and quarterly OGI monitoring, in combination with repair requirements, represents the BSER for fugitive emissions components at both new and existing compressor stations.

The EPA supports the use of continuous monitoring systems to detect fugitive emissions at compressor stations. Although at this point the EPA does not have sufficient information to include this new but rapidly advancing technology in its BSER analysis, the EPA is finalizing a pathway for owners and operators to utilize continuous monitoring technologies at well sites, centralized production facilities, and compressor stations as part of the advanced methane detection technology provisions of the rule.

b. Delay of Repair Due to Parts Unavailability

Comment: Several commenters requested that a delay of repair be allowed when parts are unavailable to do the required repairs and note that the EPA requested feedback in the November 2021 Proposal (86 FR 63174) on whether to allow delay of repair due to parts unavailability. One commenter²⁴⁵ noted that delay of repair due to unavailability of valve assembly replacement supplies was included for onshore natural gas processing plants in the December 2022 Supplemental Proposal, but questions why it was not included for other natural gas industry segments that include similar arrays of high-pressure gas valves and rely on the same types of replacement supplies. Another commenter²⁴⁶ notes the same difference and adds that the array of large valves that require special service for parts or replacement for compressor stations may be more complicated than at some natural gas processing plants. Additionally, the same commenter says that supply chain delays have lengthened delivery times for

²³⁹ *Standards of Performance for New, Reconstructed, and Modified Sources and Emissions Guidelines for Existing Sources: Oil and Natural Gas Sector Climate Review. Response to Public Comments on the November 2021 Proposed Rule and the December 2022 Supplemental Proposed Rule* (86 FR 63110, November 15, 2021; 87 FR 74702, December 6, 2022).

²⁴⁰ EPA-HQ-OAR-2021-0317-2211.

²⁴¹ EPA-HQ-OAR-2021-0317-2440.

²⁴² EPA-HQ-OAR-2021-0317-2180.

²⁴³ EPA-HQ-OAR-2021-0317-0585.

²⁴⁴ EPA-HQ-OAR-2021-0317-0814.

²⁴⁵ EPA-HQ-OAR-2021-0317-2366.

²⁴⁶ EPA-HQ-OAR-2021-0317-2483.

replacement parts and that operators can ensure that replacement parts are ordered in a timely manner but cannot control how quickly the parts will arrive. Both commenters discuss the timelines for delivery of replacement valves, which ranged between 16 and 40 weeks, depending on size, at the time of the comments.

A commenter²⁴⁷ also asserted that larger, older compressor stations were expanded over time with different compressor sizes, types, and vintages, resulting in a large array of unique valves at compressor stations. The commenter continued, saying that parts are not interchangeable between different manufacturers, models, or even different vintages of the same equipment and that if a part breaks on an older piece of equipment, the comparable part that is used for new compressors may not be the right size or configuration for the older equipment. In such cases, the appropriate parts for that equipment will need to be custom fabricated; manufacturers do not maintain an inventory of expensive parts, unique parts, or parts for older equipment. The commenter estimated that the timeline for custom fabrication of station valves can require 4 to more than 12 months, depending on the size and uniqueness of the part. Another commenter²⁴⁸ explained that in their experience, the parts most likely to be in short supply are large, unique valves used for compressor isolation or isolating sections of a facility or pipeline; these valves are not standard items, and they come in many configurations. The commenter explained that, given the size and unique specifications of each valve, it is not practical or economical to maintain a significant inventory of such items. They added that such items may require special fabrication with lead times of many months. As an example, the commenter described a recently identified leak on a 16-inch valve. Upon investigation, they determined that repair (e.g., replacing subcomponents of the large valve) was not possible and an exact replacement valve could not be ordered because the valve was obsolete. Investigation into a new replacement indicated a lead time on the order of at least 18 weeks.

Commenters also recommended that delay of repair due to parts unavailability should extend to parts other than valves. One commenter²⁴⁹ stated that compression includes an array of parts associated with the

compression driver, the compressor, and associated valving, piping, and other processing equipment. A valve is one example of a part type that may not be available for repair or replacement, but other large, unique legacy parts associated with other legacy process equipment may need to be machined or more major components may need to be constructed.

Conversely, another commenter²⁵⁰ contended that the availability of parts is not a valid concern because replacement parts could be easily procured, and operators could stockpile fugitive emission components and parts thereof prior to this rule's requirements coming into effect.

Commenters also responded to the EPA's solicitation of input on the timeline for repair upon receipt of the part and any associated documentation. One commenter²⁵¹ suggested that repairs must be completed within 30 days following the receipt of the replacement part, provided that conducting the repair would not require a unit or wellhead shutdown and that, if shutdown was required, the repair should occur during the next scheduled maintenance shutdown. Similarly, another commenter²⁵² requested that the EPA provide in the regulatory text that, where no shutdown or blowdown is needed, the operator should repair the leak within 30 days after receiving the parts. The commenter requested that where a repair requires a shutdown or blowdown, the regulatory text allow the repair to be performed during the next scheduled shutdown for maintenance after receipt of the requisite parts, not to exceed 2 years. The commenter stated that this will avoid unnecessary blowdown emissions. One commenter²⁵³ recommended that the required recordkeeping follow current NSPS OOOOa criteria, where the operator documents the delay basis and repair schedule. Another commenter suggested that the operator be required to support the necessity of delay of repair due to parts unavailability through rigorous documentation, including but not limited to: a reasonable explanation of why the operator did not have a spare part on hand; a justification of why the equipment failure was not foreseeable at any point from the date of the proposed regulations until the date of failure; proof that such failures are not common at similar compressor stations of similar age; maintenance and inspection

records supporting the non-foreseeability of the failure; proof and date that the replacement part was ordered immediately upon detection; and proof that the part was installed as quickly as possible upon receipt.

Response: In response to these comments, the EPA is allowing delay of repair that requires replacement where the replacement cannot be acquired and installed within the repair timeline due to either of the following conditions: (1) Replacement valve supplies have been sufficiently stocked but are depleted at the time of repair; or (2) a replacement fugitive emissions component or a part thereof requires custom fabrication. In either situation, the required replacement must be ordered within 10 calendar days after the first attempt at repair. The repair must be completed within 30 calendar days after receipt of the replacement or during the next scheduled shutdown for maintenance after the replacement is received (if the repair requires a shutdown). Operators must document the date the leak was added to the delay-of-repair list, the date the replacement fugitive emissions component or part thereof was ordered, the anticipated delivery date, and the actual delivery date as part of their fugitive emission survey records.

The EPA acknowledges that during the 2016 rulemaking promulgating NSPS OOOOa and the 2021 amendments, the EPA received comments requesting that the EPA allow delay of repair due to parts unavailability. The EPA declined to do so in 2016, explaining that “[t]he EPA does not agree that unavailability of supplies or custom parts is a justification for delaying repair (i.e., beyond the 30 days for repair provided in this final rule) since the operator can plan for repair of fugitive emission components by having stock readily accessible or obtaining the parts within 30 days after finding the fugitive emissions.” 81 FR 35824, 35858. In 2021, the EPA similarly expressed that it “does not agree a lack of parts is a sufficient justification to delay.”²⁵⁴

However, regarding the comment noting that the standards (and presumptive standards) for onshore natural gas processing plants in the proposed NSPS OOOOb and EG OOOOc would have allowed delay of valve repair due to depletion of valve supplies and requesting that the EPA allow the same in the fugitive emissions standards

²⁴⁷ Id.

²⁴⁸ EPA-HQ-OAR-2021-0317-0782.

²⁴⁹ EPA-HQ-OAR-2021-0317-2366.

²⁵⁰ EPA-HQ-OAR-2021-0317-0844.

²⁵¹ EPA-HQ-OAR-2021-0317-1289.

²⁵² EPA-HQ-OAR-2021-0317-0815.

²⁵³ EPA-HQ-OAR-2021-0317-0782.

²⁵⁴ *Oil and Natural Gas Sector: Emission Standards for New, Reconstructed, and Modified Sources Reconsideration 40 CFR part 60, subpart OOOOa, Response to Public Comments on Proposed Rule* (83 FR 52056, October 15, 2018), at 8–199.

for well sites and compressor stations, the EPA concludes that well sites and compressor stations face some of the same valve assembly supply constraints as onshore natural gas processing plants and that operators can ensure timely ordering of replacement fugitive components or parts thereof but cannot control replacement delivery timelines. Thus, the EPA is including similar delay-of-repair provisions for valve assembly supplies that had been sufficiently stocked but are depleted at the time of the required repair for wellsite and compressor station fugitives as for onshore natural gas processing plants in this rule. The final fugitive emissions standards for well sites and compressor stations under NSPS OOOOb (and presumptive standards under EG OOOOc) allow delay of repair due to depletion of supplies for valves only. This is consistent with the standards for onshore natural gas processing plants, which have provided such allowance for *valves only* since the standards were first promulgated in 1985, and the EPA has not received information showing difficulty of repair due to well-stocked supplies of other fugitive emissions components or parts thereof that were depleted before repair could be completed.

In addition to allowing delay of repair of valves due to depletion of supplies as described above, the final rule allows delay of repair where repair requires replacement of a custom-made fugitive emissions component or a part thereof. The comments on the November 2021 Proposal and December 2022 Supplemental Proposal also include supporting information on exceptional, infrequent circumstances where a replacement part requires custom fabrication. Specifically, the information includes insight into the quantity and variety of vintage equipment at compressor stations, the unlikelihood of manufacturers' stocking replacement parts for vintage equipment and thus the need for custom fabrication of replacement supplies, and the timeline for fabrication and delivery of custom supplies. Recent examples of extensive supply chain delays have highlighted that a delay of repair may be needed for circumstances beyond an owner or operator's control.²⁵⁵ In light of the information on the challenges and the time needed to acquire parts that require custom fabrication and the current supply chain issue, we are including in the final NSPS OOOOb and the model rule in EG OOOOc provisions for delay of repair where replacement is required

and the replacement fugitive emissions component or a part thereof requires custom fabrication. As described above, for delay of repair under either of the two specified conditions, the final rule prescribes specific timeframes for ordering and installing the parts to ensure that repair is completed in a timely manner, as well as the specific records that must be kept to demonstrate compliance with these requirements.

B. Advanced Methane Detection Technology Work Practices

In the December 2022 Supplemental Proposal, the EPA proposed a revised alternative fugitive emissions monitoring and repair program for new, modified, or reconstructed fugitive emissions sources (*i.e.*, collection of fugitive emissions components located at well sites, centralized production facilities, and compressor stations). This program was intended to provide owners and operators with the flexibility to use advanced methane detection technologies in lieu of the ground-based OGI and AVO surveys that the EPA had proposed for fugitive emissions sources. Among other things, the December 2022 Supplemental Proposal included a proposed "matrix" that would specify different screening frequencies corresponding to a range of minimum detection thresholds, in contrast to the single screening frequency and detection level proposed in the November 2021 Proposal. In addition, the EPA proposed to allow owners and operators the option of using continuous monitoring technologies as another alternative to ground-based OGI and AVO surveys and proposed long- and short-term emission rate thresholds that would trigger corrective action. The EPA also proposed monitoring plan requirements for owners and operators that chose to implement the alternative fugitive emissions monitoring approach and proposed a clear and streamlined pathway for technology developers and other entities to seek the EPA's approval for the use of advanced methane detection technologies under this alternative option.

This section of this document presents a summary of significant comments received on advanced methane detection technologies and the EPA's response to those comments, as well as certain changes in the final standards for using advanced methane detection technologies for monitoring fugitive emissions components at new and existing facilities and for conducting continuous inspection and monitoring for covers and closed vent

systems. For other comments on the proposed program and the EPA's response thereto, see chapter 5 of the RTC document, *Advanced Methane Detection Technologies*.²⁵⁶ For final standards and requirements that have not changed since the December 2022 Supplemental Proposal, the supporting rationales are not reiterated in this preamble. The rationale for those standards and requirements can be found in section IV of the preamble for the December 2022 Supplemental Proposal (87 FR 74702 at 74722–810, December 6, 2022).

1. Periodic Screening

a. Matrix Table and Screening Frequency

Comment: The EPA received considerable support for the flexibility to use advanced methane detection technologies in lieu of using OGI, EPA Method 21, or AVO to monitor fugitive emissions components in response to the December 2022 Supplemental Proposal. One commenter²⁵⁷ supported the proposed frequencies in the matrix, noting that their independent equivalency modeling matched the results of the EPA's FEAST modeling across a variety of scenarios, and supported the EPA's choices of model inputs that made assumptions based on nationally applicable factors and considerations, as these inputs apply across the country to sources in different oil and gas producing regions and basins. Other commenters^{258 259} raised concerns that the EPA's FEAST modeling overestimates the effectiveness of AVO and OGI, resulting in matrix frequencies that are overly stringent. Another commenter²⁶⁰ discussed the potential use of an alternative emission rate distribution in the model, from a study that included a larger range of emission rates than was used in the EPA's modeling.

A commenter²⁶¹ considered the minimum detection thresholds and monitoring frequencies in the proposed matrix to be insufficiently differentiated between the tiers with respect to detection levels. Several

²⁵⁶ *Standards of Performance for New, Reconstructed, and Modified Sources and Emissions Guidelines for Existing Sources: Oil and Natural Gas Sector Climate Review. Response to Public Comments on the November 2021 Proposed Rule and the December 2022 Supplemental Proposed Rule* (86 FR 63110, November 15, 2021; 87 FR 74702, December 6, 2022).

²⁵⁷ EPA-HQ-OAR-2021-0317-2433.

²⁵⁸ EPA-HQ-OAR-2021-0317-2387.

²⁵⁹ EPA-HQ-OAR-2021-0317-2428.

²⁶⁰ EPA-HQ-OAR-2021-0317-2405.

²⁶¹ EPA-HQ-OAR-2021-0317-1686, -2345.

²⁵⁵ EPA-HQ-OAR-2021-0317-2483.

commenters^{262 263} raised concern that the 30 kg/hr periodic screening tier provides a less stringent work practice for emissions reduction and urged the EPA to remove the 30 kg/hr detection tier.

Another commenter²⁶⁴ stated that advanced methane detection technologies are evolving rapidly and are a key component of the commenter's strategy for broader emission reductions. The commenter believed that these technologies have the potential to be more effective at finding leaks on a broader scale, allowing for faster detection and mitigation, leading to a greater reduction in methane emissions. This commenter was concerned that there may be inadvertent disincentives that are contrary to the intent of the EPA, which is to encourage innovation resulting in meaningful emissions reductions. The commenter was concerned that disincentives may encourage operators to simply continue their existing OGI survey programs as the default option, which could hinder broad development and adoption of advanced methane detection technologies.

Response: Regarding the modeling conducted to develop the periodic screening matrices in the December 2022 Supplemental Proposal, while the EPA acknowledges there are alternative inputs available for the models, we incorporated the best available information from recent studies to characterize a distribution for both common leaks and super-emitters. The results of our fugitive emissions modeling fell within the ranges observed in other literature assessments. As mentioned above, we received supportive comments for our modeling. The commenters who expressed otherwise provided limited additional peer-reviewed data with which we could revise our model assumptions; much of the data focused on studies collected using a singular technology (e.g., aerial survey), and the emission distribution appeared to be weighted toward emissions this specific methane detection technology could identify. While the EPA's emission distribution in our model also was developed using studies conducted with aerial surveys, we augmented that distribution with ground-level studies to get a more complete emission distribution, including the lower-level emissions. Therefore, we believe the results from the modeling conducted for the

December 2022 Supplemental Proposal are well-supported.

With the continued development and deployment of advanced methane detection technology, we expect further study on the distribution of methane emissions from this sector, in particular after promulgation of this rule providing a pathway for the use of advanced technologies. As additional studies are conducted on emission distributions across this sector, it is possible that the underlying emissions rate distribution in our modeling could potentially be updated in the future. However, the inputs in the modeling conducted for the December 2022 Supplemental Proposal were based on the best information available to the EPA during this rulemaking. Therefore, we continue to believe that the modeling results are well-supported and appropriate for the development of the periodic screening matrices.

In this final rulemaking, the EPA finalized the proposed matrices tables (tables 3 and 4 in NSPS OOOOb and EG OOOOc) with some adjustments in response to comments. Several commenters questioned whether an annual OGI survey is necessary in order for the use of certain periodic screening technologies to be equivalent to the fugitive emissions monitoring requirements discussed in section XI.A of this document. Based on the comments we received, the EPA reviewed the modeling results, reexamined the effectiveness of an annual OGI survey on the matrix tiers, and evaluated the uncertainty in the modeling results. We found that for the lower tiers of the matrix tables (corresponding to the most sensitive advanced methane detection technologies), the effectiveness of the annual OGI survey in reducing methane emissions in the FEAST model was minimal. Further, we found that at the highest tiers of the matrix (corresponding to the least sensitive advanced methane detection technologies), the annual OGI survey accounted for the bulk of the modeled emission reductions, and the periodic screening itself yielded relatively small reductions in emissions. Based on this additional review, we are revising the periodic screening matrices tables in the final rule by removing the proposed highest tier corresponding to the least sensitive technologies (≤ 30 kg/hr) and by removing the proposed requirement to conduct an annual OGI survey at the lowest detection threshold tier (*i.e.*, 1 kg/hr) in table 1 (which applies to well sites, centralized production facilities, and compressor stations subject to AVO inspections with quarterly OGI

monitoring surveys). We have also made a small adjustment in the monthly survey.

The EPA is finalizing the proposed matrices (with some adjustments as described above), which the EPA believes reflect at least the same levels of emission reductions as those from complying with the required fugitive emissions work practice standards for well sites, centralized production facilities, and compressor stations. In addition, in response to comments on the importance of incentivizing the use of advanced methane detection technologies, the EPA is including in the final rule an interim matrix in lieu of table 1 that will apply for the next 2 years. The EPA agrees with the comments that advanced methane detection technologies have the potential to be more effective at finding leaks more quickly than traditional ground-based fugitive emission surveys; therefore, it is important to develop a framework that encourages innovation and the continued development of advanced methane detection technologies. The EPA acknowledges that these technologies will only continue to develop if owners and operators have a desire to implement them. Based on our current understanding of the state of advanced methane detection technologies, while there are some technologies that can measure at the lowest detection threshold levels in the periodic screening matrices under certain conditions, we currently do not have available data on any technologies that can achieve these minimum detection thresholds at all sites and in all conditions. Because these technology developers have had less than a year (since publication of the December 2022 Supplemental Proposal) to understand and test the proposed target detection thresholds the technologies need to meet, there has not been adequate time to develop data that push the detection thresholds down to the lowest levels of the proposed periodic screening matrix (at 1 to 2 kg/hr). For the reason explained above, it is understandable that there may be some reluctance at this time to use such technologies to comply with NSPS OOOOb at these very low detection thresholds until more data is generated to confirm their detection capabilities. We believe that, if given opportunities to use the advanced technologies, over time users will show that these technologies can meet the minimum detection thresholds in these lowest levels of the periodic screening matrix in table 1. We therefore agree with the commenter that it is

²⁶² EPA-HQ-OAR-2021-0317-2405.

²⁶³ EPA-HQ-OAR-2021-0317-2430.

²⁶⁴ EPA-HQ-OAR-2021-0314-2360.

critically important to incentivize the early adoption of these alternative technologies. To that end, as part of the final rule, we have developed an interim periodic screening that will apply in lieu of the matrix table for well sites, centralized production facilities, and compressor stations subject to AVO inspections with quarterly OGI monitoring surveys (table 1 in NSPS OOOOb) for the next 2 years (*i.e.*, until March 9, 2026). Under this interim periodic screening matrix, the lowest detection threshold is ≤ 3 kg/hr, and it requires quarterly screening frequency. While we are increasing the minimum detection threshold to ≤ 3 kg/hr in this interim 2-year period to incentivize the use of advanced technologies, the EPA expects that these technologies will be able to achieve much better (*i.e.*, lower) detection thresholds in many use cases, which will be reflected in the records once a technology has been approved by the EPA as an alternative and deployed for purposes of NSPS OOOOb. At the end of the interim 2-year period, the periodic screening matrix in table 1 of NSPS OOOOb, which sets survey frequencies for lower detection thresholds (≤ 1 kg/hr and ≤ 2 kg/hr), will apply. The EPA has chosen not to provide an interim periodic screening in lieu of the matrix table for well sites, centralized production facilities, and compressor stations subject to AVO inspections with semiannual OGI monitoring surveys (table 2 in NSPS OOOOb). The periodic screening matrix for these sources already allows using an advanced methane detection technology with a detection threshold of < 5 kg/hr level. Because we anticipate owners and operators will conduct the screenings of all their sites (those subject to table 1 and those subject to table 2) on the same schedule and table 2 already accommodates the interim periodic screening level for table 1, EPA has determined that it is unnecessary to create an interim periodic screening for sites subject to table 2.

Comment: Several commenters^{265 266} asked that the EPA allow NSPS OOOOb sources to comply with the advanced methane detection technology provisions in NSPS OOOOb. One of these commenters requested that the EPA consider mechanisms to enable sources subject to NSPS OOOOb to demonstrate compliance with the fugitive emission requirements in NSPS OOOOb using any advanced methane detection technologies approved in NSPS OOOOb prior to the effective date of state or Tribal plans approved under

EG OOOOb. Another commenter raised concerns that the time needed to seek approval to use these advanced methane detection technologies for existing sources through the AMEL process and EG OOOOb state plan implementation could take years.

Response: The EPA agrees with the suggestion to allow a mechanism outside of the AMEL process to allow existing facilities subject to NSPS OOOOb to use advanced methane detection technologies. We agree that a comprehensive periodic screening program that uses an advanced methane detection technology approved by the EPA under NSPS OOOOb in which all the emissions detected are repaired in accordance with NSPS OOOOb will result in emission reductions similar to or better than the reductions under the existing fugitive emissions work practice at well sites and compressor stations in NSPS OOOOb. However, the periodic screening matrices in NSPS OOOOb and in EG OOOOb reflect the overall fugitive emissions reductions equivalent to the reductions that would be achieved for that site in the standard fugitive emissions work practice using OGI and AVO under NSPS OOOOb (and presumptive standards under EG OOOOb), which includes equipment not included in the definition of “fugitive emissions component” in NSPS OOOOb. The EPA can only determine that the same or better emission reductions are achieved if an owner or operator complies with the advanced methane detection technology work practices in NSPS OOOOb by repairing all fugitive emissions, including emissions from equipment not included in the definition of “fugitive emissions component” in NSPS OOOOb, such as uncontrolled tanks, and performing required investigative analyses. Therefore, as discussed in section IX.C of this preamble, we are amending the regulatory text in NSPS OOOOb to include a provision that compliance with the advanced methane detection technology work practices approved under NSPS OOOOb will be deemed compliance with the applicable fugitive emissions standards for the same facility in NSPS OOOOb.

b. Technology Flexibility

Comment: Commenters^{267 268} encouraged the EPA to incorporate a pathway into the final rule to allow for the use of a combination of technologies, both traditional and advanced, to achieve equivalent emissions reductions. The EPA received

several comments requesting additional flexibility in the matrix, including the allowance to use multiple technologies at a single site in a layered or tiered fashion. Commenters²⁶⁹ were concerned that by not conducting equivalency modeling for a combination of alternative technologies, the proposed matrix would fail to provide sufficient flexibility for owners and operators that find it necessary to apply multiple advanced technologies due to equipment limitations, operating conditions, or economic factors. Several commenters^{270 271} discussed that the matrix should account for the occasional need to deploy different monitoring technologies due to seasonal environmental conditions, noting that inclement weather, including wind, rain, and ground snow cover, can adversely affect methane detection performance. A commenter recommended allowing OGI surveys during the months when advanced detection technologies cannot be deployed.

Some commenters²⁷² suggested that continuous monitoring technologies may fit within the periodic screening framework and urged the EPA to consider such technologies within that context. Another commenter recommended that continuous monitoring be incorporated with periodic screening to create a single framework for alternative methane detection technology.

Response: The EPA agrees that the rule should allow for the use of multiple technologies at a single site and finds that this approach would provide valuable flexibility for owners and operators while continuing to achieve a degree of monitoring performance that is equivalent to the fugitive emissions monitoring requirements in this rule. Therefore, in the final rule we are allowing the use of one or more alternative test methods for advanced methane detection technology to conduct periodic screening. The frequency for conducting periodic screening events will be based on the methane detection technology with the highest sensitivity. For example, if an owner or operator uses methane detection technology with a detection threshold of ≤ 10 kg/hr, the owner or operator may choose when conducting bimonthly screening events to use any methane detection technology with a detection threshold of ≤ 10 kg/hr. We also agree that environmental

²⁶⁵ EPA-HQ-OAR-2021-0317-2430.

²⁶⁶ EPA-HQ-OAR-2021-0317-2428.

²⁶⁷ EPA-HQ-OAR-2021-0317-2360.

²⁶⁸ EPA-HQ-OAR-2021-0317-2388.

²⁶⁹ EPA-HQ-OAR-2021-0317-2391.

²⁷⁰ EPA-HQ-OAR-2021-0317-2405.

²⁷¹ EPA-HQ-OAR-2021-0317-2235.

²⁷² EPA-HQ-OAR-2021-0317-2448.

conditions can adversely affect some methane detection technologies. In the final rule we allow the owner or operator to conduct an OGI survey in place of a periodic screening event at any time. The planned use of multiple technologies, including OGI, must be incorporated into the site-specific monitoring plan.

The EPA also agrees that continuous monitoring technologies can fit within the periodic screening framework, especially those technologies that may not be able to comply with the requirements in the continuous monitoring framework. While it was not explicitly stated in the December 2022 Supplemental Proposal, we intended for continuous monitoring technology to be considered as a candidate for the periodic screening approach. The EPA continues to consider the periodic screening approach a valid pathway for continuous methane detection technology.

c. Spatial Resolution

Comment: Several commenters^{273 274} discussed that some measurement technologies have tighter spatial resolution which may enable the detection of equipment-specific emissions, and as such, use of these technologies may not require a follow-up OGI survey of the entire site. One commenter mentioned that one may be able to conclusively identify the fugitive emissions component with certain measurement technologies. Another commenter²⁷⁵ urged the EPA to require follow-up OGI surveys only within the general area of detection from a periodic screening event.

Response: The EPA finds these comments compelling and in the final rule is incorporating the concept of spatial resolution of measurement technology into the follow-up actions an owner or operator must take when a periodic screening event results in a confirmed detection. We have included three classifications for spatial resolution in the final rule: (i) facility-level spatial resolution, meaning an alternative test method with the ability to identify emissions within the boundary of a well site, centralized production facility, or compressor station; (ii) area-level spatial resolution, meaning a technology with the ability to identify emissions within a radius of 2 meters of the emissions source; and (iii) component-level spatial resolution, meaning a technology with the ability to identify emissions within a radius of 0.5

meters of the emissions source. Entities requesting an alternative test method for advanced methane measurement technology would identify and verify the spatial resolution of the measurement technology as part of the request.

In the final rule, for periodic screening events conducted with technologies that have facility-level spatial resolution, we have maintained the follow-up actions an owner or operator must take in response to a confirmed detection that were outlined in the December 2022 Supplemental Proposal. However, for periodic screening events conducted with technologies that have area-level or component-level spatial resolution, we have targeted the follow-up actions the owner or operator must take. The follow-up monitoring that must be conducted for a confirmed detection during a periodic screening event using a technology with area-level spatial resolution includes a monitoring survey of all the fugitive emissions components located within a 4-meter radius of the location of the confirmed detection and, if the confirmed detection occurred in a portion of a site with a storage vessel or closed vent system, inspection of all covers and closed vent systems that are connected to all storage vessels and closed vent systems that are within a 2-meter radius of the location. The follow-up monitoring that must be conducted for a confirmed detection during a periodic screening event using a technology with component-level spatial resolution includes a monitoring survey of all the fugitive emissions components located within a 1-meter radius of the location of the confirmed detection and, if the confirmed detection occurred in a portion of a site with a storage vessel or closed vent system, inspection of all covers and closed vent systems that are connected to all storage vessels and closed vent systems that are within a 0.5-meter radius of the location. The EPA is requiring inspection of the entire closed vent system in order to identify a potential cause of the failure. The EPA has also incorporated the requirement to verify the spatial resolution of a measurement technology as part of the alternative test method provisions.

d. Root Cause Analysis

Comment: Several commenters^{276 277} supported the requirement that an owner or operator investigate the source and cause(s) of significant emissions found through periodic screening

events. However, many commenters took exception to the proposed use of “root cause analysis” for investigating potential causes of emissions. One commenter²⁷⁸ noted that the concept of “root cause analysis” is embedded in numerous other regulatory and non-regulatory programs and has varied meaning and purpose in each application. Another commenter²⁷⁹ asserted that the phrase “root cause analysis” has connotations that lead to a much more involved process than the EPA appears to envision in this rule. Many of these commenters suggested that “root cause analysis” be replaced by “investigative analysis,” broadly meaning the owner or operator must determine what caused the emissions event to occur and take steps to ensure that it will not happen again.

Response: The EPA agrees with the concern raised by commenters and in the final rule requires an investigative analysis as opposed to a root cause analysis. For the purpose of this final rule, an investigative analysis is the determination of the underlying primary and other contributing cause(s) of the emissions event. For a control device, the investigative analysis must include a determination that the control device is operating in compliance with the applicable requirements, and if not, what actions are necessary to bring the control device into compliance and prevent future failures of the control device from the same underlying cause(s). For a cover or closed vent system, the investigative analysis must include a determination of whether the system was operated outside of the engineering design analysis and whether updates are necessary for the cover or closed vent system to prevent future emissions from the cover or closed vent system.

2. Continuous Monitoring

a. Continuous Monitoring System Criteria

Comment: Several commenters^{280 281} requested that the framework for continuous monitoring set action levels based on the concentration of emissions as an alternative to the action levels based on the mass rate of emissions in order to allow owners and operators to use a broader range of continuous monitoring systems. One commenter²⁸² supported the EPA’s inclusion of health checks for devices within the continuous monitoring system but

²⁷³ EPA-HQ-OAR-2021-0317-2406.

²⁷⁴ EPA-HQ-OAR-2021-0317-2366.

²⁷⁵ EPA-HQ-OAR-2021-0317-2432.

²⁷⁶ EPA-HQ-OAR-2021-0317-2428.

²⁷⁷ EPA-HQ-OAR-2021-0317-2363.

²⁷⁸ EPA-HQ-OAR-2021-0317-2402.

²⁷⁹ EPA-HQ-OAR-2021-0317-2298.

²⁸⁰ EPA-HQ-OAR-2021-0317-2340.

²⁸¹ EPA-HQ-OAR-2021-0317-2235.

²⁸² EPA-HQ-OAR-2021-0317-2363.

suggested that the health checks rely on functionality instead of connectivity. Several commenters²⁸³ requested more flexibility as to how often these systems must transmit data. Other commenters²⁸⁴ contended that flexibility in the downtime requirement is necessary, as typical downtime can be 4 or more days per month for remote locations.

Response: The EPA agrees that it is important to facilitate the use of a broad range of continuous monitoring systems in the advanced methane detection technology provisions of this rule, because they allow more rapid detection of leaks and thus an enhanced ability to promptly respond and prevent emissions. As such, we have expanded the definition of a continuous monitoring system to allow systems beyond those that determine mass emission rate only by noting these systems must determine the “mass emission rate or equivalent.” The EPA also agrees with the commenter that the health checks of the system can be based on function rather than connectivity and that more flexibility in the transmission of data is appropriate. In the final rule we require data to be transmitted at least once every 24 hours.

The EPA does not agree that additional flexibility in the downtime requirements is appropriate, even for remote locations. In order to demonstrate that a continuous monitoring system is equivalent to the required OGI/AVO monitoring for fugitive emissions component affected/designated facilities, it is important for these systems to collect and analyze data with a limited amount of downtime. If the downtime is too great, we cannot ensure that the emissions reductions achieved by the alternative continuous monitoring method are equivalent to those from the work practice that has been determined to be BSER. If a continuous monitoring system cannot meet the operational downtime in the final rule and an owner or operator does not want to conduct surveys with OGI or EPA Method 21, the owner or operator may choose to use a continuous monitoring system that does meet the downtime requirement in the rule or may choose to use the alternative periodic screening option.

b. Detection Threshold

Comment: Several commenters^{285 286} did not agree with the requirement in the December 2022 Supplemental

Proposal that continuous monitoring systems be capable of measuring emissions at an “order of magnitude” lower than (*i.e.*, 1/10 of) the proposed action levels. One commenter²⁸⁷ mentioned that this requirement is overly prescriptive and appears to be technology-specific rather than outcome-based and technology-agnostic.

Response: The EPA agrees with the commenters and in the final rule requires a detection threshold of 0.40 kg/hr (0.88 lb/hr) above a baseline, which is based on one-third the action level. The requirements in the December 2022 Supplemental Proposal were based on the method detection limit requirements for alternative test methods in the fence line monitoring program in the refinery rule.²⁸⁸ Requiring alternative measurement technologies used in the refinery fence line monitoring program to measure an order of magnitude below the action level is appropriate because in that program, the difference between the high and low sample results during a measurement period are used to calculate the site’s benzene concentration difference; therefore it is important to be able to differentiate the low-concentration measurements for benzene we expected around some refineries. In this final rule, the requirement for technology to be able to detect methane an order of magnitude below the action level is unnecessarily restrictive for real-time systems measuring methane mass emission rates, which may use concentration, meteorology, and modeling to calculate these rates, all of which have uncertainty built into the detection limit. Because these systems will be measuring a mass emission rate and not a concentration difference, it is less important to differentiate between the measurements across the site. It is only important that the technology be able to measure methane at background levels in order to be able to develop a site-specific baseline for methane, and methane is ubiquitous in the atmosphere at levels that should not present a concern for detection. For these reasons, we are requiring continuous monitoring alternative methane detection technologies to have a sensitivity of one-third of the lowest action level, 0.4 kg/hr (0.88 lb/hr). We note this requirement is also consistent with the EPA’s approach for setting emission limits that are at least three times the representative detection limit. Such an approach ensures that the standard is at a level that addresses

measurement variability and is in a range that can be measured with reasonable precision. Requiring the detection limit of continuous monitoring technologies to be at least one-third of the action level will ensure that measurements made near the action level are of reasonable precision.

c. Site-Specific Emissions Baseline

Comment: Several commenters²⁸⁹ raised concerns over the long-term 1.2 or 1.6 kg/hr action levels, because these emission rates are well below the baseline emissions for many sites. Other commenters^{290 291} believed it critical that the follow-up response actions are tied not to detection limits but to action levels and that those action levels be levels that account for the site’s baseline emission rates. One commenter²⁹² noted that other regulated sources can contribute to substantial temporal variability in the baseline emission rate and provided the example of methane slip from gas-fired compressors, which can vary depending on compressor operating setpoints and maintenance. An additional commenter²⁹³ suggested that the concept of a baseline be used to establish an emissions profile and action levels be incremental to that baseline. The commenter further suggested that since the baseline is meant to capture normal emissions from the facility, while responses to the long-term and short-term action levels are meant to reduce fugitive emissions, the baseline period should be 90 days.

Response: The EPA agrees that the action level should be incremental to the site-specific baseline emissions. In the final rule, we are revising the action level to be a mass emission rate that is above the site-specific baseline emissions. Based on the recommendations of the commenters, we are also establishing requirements for how and when the determination of the site-specific baseline is performed. The baseline emissions must be established after the initial installation of a continuous monitoring system or when there is a major change in the processing equipment at the site. The owner or operator must inspect and repair all fugitive components, covers, and closed vent systems and verify that control devices are in compliance with applicable requirements prior to starting the baseline determination period.

The EPA disagrees with the suggested 90-day baseline period. We consider 30

²⁸³ EPA-HQ-OAR-2021-0317-2248.

²⁸⁴ EPA-HQ-OAR-2021-0317-2409.

²⁸⁵ EPA-HQ-OAR-2021-0317-2235.

²⁸⁶ EPA-HQ-OAR-2021-0317-2333.

²⁸⁷ EPA-HQ-OAR-2021-0317-2336.

²⁸⁸ 40 CFR 63.658(k)(3).

²⁸⁹ EPA-HQ-OAR-2021-0317-2433.

²⁹⁰ EPA-HQ-OAR-2021-0317-2346.

²⁹¹ EPA-HQ-OAR-2021-0317-2433.

²⁹² EPA-HQ-OAR-2021-0317-2333.

²⁹³ EPA-HQ-OAR-2021-0317-2307.

days sufficient time to measure the variability of a site. Therefore, the baseline emissions are determined as the mean emission rate for 30 operating days, minus any time periods where maintenance events are conducted. This site-specific baseline emission rate must be no more than 10 times the site's applicable 90-day action level (*i.e.*, 16 kg/hr for well sites with major production and processing equipment (including small well sites), centralized production facilities, and compressor stations, or 12 kg/hr for wellhead only well sites).

d. Mass Emission Rate Reduction Plan

Comment: One commenter²⁹⁴ mentioned that the December 2022 Supplemental Proposal was not clear on how operators would deal with subsequent increases to the rolling average if corrective action had already been taken for the initial event.

Response: The EPA agrees with the commenter that the December 2022 Supplemental Proposal was not clear on how to handle this situation. In the final rulemaking, owners and operators who conduct continuous monitoring with advanced methane detection technologies will initially (prior to conducting continuous monitoring) develop a site-specific baseline that accounts for normal process fluctuations. This site-specific baseline will be subtracted from the monitored emissions when determining whether there is an exceedance of an action level. As such, the EPA anticipates that there should not be instances where the rolling average emissions continue to increase once the primary and underlying causes of the original exceedance of the action level is addressed.

3. Alternative Test Method

a. Administrator Delegation

Comment: Several commenters²⁹⁵ expressed that the alternative test method approval process should enable expeditious and thorough review of advanced technologies. An additional commenter²⁹⁶ supported the EPA's proposal to allow operators to utilize the matrix to comply with CAA section 111(h)(1) and to approve alternative test methods under 40 CFR 60.8(b)(3), as this process enables operators to deploy technologies meeting the specifications of the matrix and encourages greater use of alternative technologies that can

better detect emissions, resulting in greater emission reductions.

Response: The EPA agrees that the alternative test method review process should be expeditious without sacrificing thoroughness. To that end, the EPA proposed a process for approving alternative test methods in 40 CFR 60.5398b(d), which is similar to the process in 40 CFR 60.8(b)(3) but specifically tailored towards the types of advanced technologies that are in use or under development in the oil and natural gas sector.

b. Super-Emitter Technology

Comment: The EPA received several comments^{297 298} on the December 2022 Supplemental Proposal regarding the lack of criteria for remote sensing technologies used in the Super Emitter Program. One of these commenters believed these criteria should be based on the same proposed tenets as those for the advanced methane detection technologies, including detection limits based on a probability of detection curve and quantification accuracy. Another commenter stated that the EPA should use the alternative test method approval process to approve technologies for use in the Super Emitter Program. Another commenter²⁹⁹ maintained that third parties who are certified under the Super Emitter Program should not face a higher barrier to monitoring than operators themselves.

Response: The EPA agrees with these comments. In this final rule, the EPA has included provisions to approve technologies used in the Super Emitter Program in 40 CFR 60.5398b(d), which are the same provisions that will be used to approve alternative methane detection technologies used by owners and operators. The EPA pre-approving the remote sensing technologies used by third parties under the Super Emitter Program will provide additional confidence in the data being provided by the third parties to the EPA, which will allow for expedited review of the data and help to ensure the data provided to the owner or operator is accurate and actionable.

c. Request for Alternative Test Methods

Comment: One commenter³⁰⁰ requested we remove the requirement that an alternative test method, such as a continuous monitoring system, must be "commercially available" to be approved for use under the rule, as this

unintendedly prevent in-house technology developed by an owner or operator from being used. Several commenters^{301 302} requested that the EPA clarify the information companies must include in a request for an alternative test method. One commenter added that this clarification is necessary to support the EPA's ability to efficiently review and approve complete applications that demonstrate equivalent or better methane detection and reductions. Another commenter³⁰³ suggested that technology vendors include proof of results in their applications, including an accredited third party's validation, as they relate to detecting methane leak events, including field-proven evidence and technology validation accurately capturing events for a given range of detection and quantification thresholds. Several commenters requested that the EPA clarify what is meant by commercial availability of alternative leak detection technologies.

Response: Based on the comments received, in the final rule the EPA has changed the term describing the alternative technology from "commercially available" to "readily available." We have also provided clarification that readily available technology includes equipment or technology developed by an owner or operator for internal use and/or use by external partners. The EPA has also clarified the information that must be included in a request for an alternative test method for advanced methane detection technology. In the final rule, the request for an alternative test method must include contact information, description of the measurement technology, scientific theory of the measurement, potential limitations, how the measurement is translated to a mass emission rate, detailed workflow, information on any models used, a-priori methods, how all data are collected and transformed from measurement to end user, supporting information verifying that the technology meets the claimed detection threshold(s) as applied in the field, including published reports produced by the candidate or outside entity, standard operating procedures, formal alternative test method procedures, and information on the spatial resolution of the measurement technology. Requests for an alternative test method for advanced methane detection technology must be submitted to the EPA through the alternative methane detection

²⁹⁴ EPA-HQ-OAR-2021-0317-2326.

²⁹⁵ EPA-HQ-OAR-2021-0317-2355.

²⁹⁶ EPA-HQ-OAR-2021-0317-2342.

²⁹⁷ EPA-HQ-OAR-2021-0317-2366.

²⁹⁸ EPA-HQ-OAR-2021-0317-2483.

²⁹⁹ EPA-HQ-OAR-2021-0317-2433.

³⁰⁰ EPA-HQ-OAR-2021-0317-2409.

³⁰¹ EPA-HQ-OAR-2021-0317-2348.

³⁰² EPA-HQ-OAR-2021-0317-2226.

³⁰³ EPA-HQ-OAR-2021-0317-2340.

technology portal at <https://www.epa.gov/emc/oil-and-gas-alternative-test-methods>.

C. Super Emitter Program

In the December 2022 Supplemental Proposal we proposed the Super Emitter Program to establish a pathway by which an EPA-certified entity (*i.e.*, third-party notifier) may provide credible, well-documented identification of a super-emitter emissions event using one of several permitted remote-sensing technologies and approaches to the responsible owner or operator. Once notified of the event at a site they own or operate, owners and operators would be required to perform a root cause analysis to identify the source of the super-emitter event and take corrective actions to address the emissions source. As described in this section, the EPA received comments on the following aspects of the Super Emitter Program: (1) Statutory authority for the program, (2) remote sensing methane detection technology, (3) certification of third parties, (4) notifications by third parties, and (5) requirements for owners and operators. In response to these comments, the EPA has made targeted changes to the Super Emitter Program, which are described in detail in section X.C of this document.

Provided in this section are some of the significant comments on the proposed program and the EPA's response thereto. For other comments on the proposed program and the EPA's response thereto, see chapter 14 of the RTC document, Super Emitter Program.³⁰⁴

1. Statutory Authority

In the December 2022 Supplemental Proposal, the EPA had proposed for comment two legal frameworks in support of the Super Emitter Program (87 FR 74752). Under the first legal framework, the EPA would treat a super-emitter event as a separate and distinct affected facility under NSPS OOOOb (or a designated facility under EG OOOOc), and the proposed BSER for this affected facility/designated facility was the requirement that an owner or operator, upon receiving a notice of a super-emitter event from an EPA-certified third party, must take action to identify and address the source of the

super-emitter event. Under the second legal framework, the Super Emitter Program functioned as an additional compliance assurance measure for affected facilities/designated facilities subject to numeric performance standards. Under that second framework, for fugitive emissions component affected facilities/designated facilities, the Super Emitter Program was proposed as part of the BSER for the fugitive emissions standard at well sites and compressor stations, which would include a requirement to repair components that have been identified as the source of a super-emitter event. As discussed below, in response to the comments on both legal frameworks, the EPA has revised the Super Emitter Program since the December 2022 Supplemental Proposal. The final Super Emitter Program, which the EPA is establishing pursuant to the authorities provided by CAA sections 111 and 114(a), is based on the second legal framework; however, as revised, it will be the EPA, not a third party, that will notify owners and operators of super-emitter events, and such notification will be based on data submitted by EPA-certified third parties using EPA-approved detection technology, and will be issued only after the EPA has reviewed the data and deemed it to be complete and accurate. In addition to the responses to comments below, please also see section X.C of the preamble for a more detailed discussion of the legal frame for the final Super Emitter Program.

Comment: A number of commenters questioned the legality of the first proposed legal framework, which defines a super-emitter event as an affected facility/designated facility. One commenter³⁰⁵ notes that the EPA may only regulate two types of sources under CAA section 111(b) and (d): new sources (including modified sources) and existing sources; however, a super-emitter source is created by an event, not construction or modification, and therefore is neither a new nor existing source under CAA section 111. Another commenter³⁰⁶ similarly questions the legality of a super-emitter affected facility/designated facility, noting that it is created by a third-party notification and could not be said to exist prior to such notification.

Response: Because the EPA is finalizing the program based on the second legal framework, the legal concerns raised by these commenters regarding the creation of a new super-emitter affected/designated facility

under the first legal frame are now moot.

Comment: One commenter³⁰⁷ states that the EPA's focus on compliance assurance fits particularly well with the goals of the program and with the problem of super-emitters. Emissions events exceeding 100 kg/hr indicate major problems at the site resulting from either noncompliance or serious operational issues. The commenter stated that the EPA has broad authority under CAA section 114 to accept and use third-party monitoring data for purposes related to CAA section 111, including ensuring compliance. The commenter asserted that the Super Emitter Program does not and should not replace obligations on the part of owners and operators to reduce methane emissions from affected and designated facilities under the rules. Rather, the commenter views the Super Emitter Program as an additional backstop to ensure that the unique problems posed by super-emitters are timely addressed.

Another commenter³⁰⁸ however, states that the proposed Super Emitter Program is not lawful. According to the commenter, Congress did not under the CAA to convey to the EPA the authority to delegate the monitoring of regulated facilities to third-party members of the public for use by the EPA for compliance, supervision and enforcement. The commenter claims that, in effect, the EPA would be delegating to groups with unverified qualifications and technical expertise, according to the commenter an unprecedented action. The commenter claims that this provision of the proposed rules is also a violation of the separation of powers of the U.S. Constitution where the EPA is seeking to legislate and grant legal authority to itself to delegate regulatory authority to third-party members of the public to monitor and report on regulated facilities, a legislative act that resides solely with Congress.

Other commenters³⁰⁹ similarly observe that the program as proposed would be the first time that the EPA has asserted authority under the CAA to create regulatory obligations for affected facilities based on monitoring conducted by unaffiliated third parties and without playing any role at all in verifying the information before imposing legal obligations on other private parties. In support of this unusual delegation of regulatory authority, these commenters asserted, the EPA characterizes the program as

³⁰⁴ *Standards of Performance for New, Reconstructed, and Modified Sources and Emissions Guidelines for Existing Sources: Oil and Natural Gas Sector Climate Review. Response to Public Comments on the November 2021 Proposed Rule and the December 2022 Supplemental Proposed Rule* (86 FR 63110, November 15, 2021; 87 FR 74702, December 6, 2022).

³⁰⁵ EPA-HQ-OAR-2021-0317-2398.

³⁰⁶ EPA-HQ-OAR-2021-0317-2202.

³⁰⁷ EPA-HQ-OAR-2021-0317-2433.

³⁰⁸ EPA-HQ-OAR-2021-0317-2227.

³⁰⁹ EPA-HQ-OAR-2021-0317-2301, -2483.

simply a BSER requiring monitoring and correction of unintentional releases, akin to LDAR,³¹⁰ but evades the central concern that it is private parties—not the EPA, states, or regulated entities—who would be monitoring, notifying, and triggering the associated regulatory obligations.

Another commenter³¹¹ agrees with the EPA on the importance of identifying and addressing large emissions events. The commenter acknowledges that emissions from such events have the potential to be much greater than those from normal operations at a given facility and shares the EPA's interest in seeking to reduce the incidence of such large emissions events. However, like other commenters mentioned above, this commenter similarly observed that the proposed program was unique in that it would be the first time under the CAA that the EPA asserts authority to create regulatory obligations for affected facilities based on monitoring conducted by unaffiliated third parties. Claiming that the EPA did not explain the legal basis for establishing such a requirement, the commenter states that an explanation from the EPA is essential to understanding whether such a novel provision is legally viable.

Response: In light of the comments above and discussed elsewhere in this section regarding other aspects of the proposed Super Emitter Program, the EPA has made targeted revisions to the Super Emitter Program since the December 2022 Supplemental Proposal. The final Super Emitter Program, which the EPA is establishing pursuant to CAA sections 111 and 114(a), is based on the second proposed legal framework.³¹² First, as one commenter observes, the EPA has broad authority under CAA section 114(a) to accept and use third-party monitoring data for purposes related to CAA section 111, including better understanding the sources of large emitting events and assuring compliance with its regulations. CAA 111(a) authorizes the EPA to obtain any information necessary for the implementation of the CAA from any person “the EPA believes may have information necessary for the purposes

of [implementing the CAA].” While the Super Emitter Program does not specifically require or request any third party to provide information on super-emitter events to the EPA, anyone can voluntarily provide such information to the EPA. It is the EPA's long-standing position that “information will be considered to have been provided . . . under section 114 of the Act . . . if its submission could have been required under section 114. . . .” 40 CFR 2.301(b)(2). Also, as discussed in detail in section X.C and further below, CAA 114(a) authorizes the EPA to require the owners and operators of the source of the super-emitter event to investigate and report the conclusions of that investigation to the EPA. As explained below, the final Super Emitter Program requires such actions from owners and operators upon their receipt of an EPA notice of a super-emitter event based on data submitted by EPA-certified third parties using EPA-approved technology. The EPA will send such notices only after having reviewed and deemed the data to be complete and accurate.

Second, for super-emitter events caused by regulated sources, the EPA has separate authority under CAA section 111 to ensure compliance with its regulations where a notification and subsequent investigation reveal noncompliance with those regulations. Much of the equipment likely to cause a super-emitter event is or will be subject to regulation under CAA section 111 (*i.e.*, NSPS OOOO, OOOOa, OOOOb, or state/Federal plans pursuant to EG OOOOc). For example, a super-emitter event might be caused by a regulated thief hatch that is open despite the EPA's requirement that thief hatches remain closed. In these cases, the Super Emitter Program serves an additional compliance assurance measure for the regulated equipment by notifying owners and operators of data demonstrating super-emitter events and requiring that they investigate and identify the source of the super-emitter event. Specifically, the Super Emitter Program serves as additional monitoring to inform and aid owners and operators in complying with the relevant NSPS or standards in state and Federal plans. Further, the EPA proposed and is finalizing the requirement under its fugitive emissions standards that where the source of the super-emitter event was a fugitive emissions component under NSPS OOOOb or a state or Federal Plan implementing EG OOOOc, the owner and operator must follow the repair requirements in the fugitive emissions work practice standards in NSPS OOOOb or the applicable state or

Federal plan. As explained in the December 2022 Supplemental Proposal, the EPA considered this as part of the BSER for fugitive emissions at well sites and compressor stations.

In response to comments questioning the legality of allowing third party monitoring and notifications to directly trigger regulatory obligations, the EPA has revised the proposed program such that the EPA will play an essential oversight role in the final Super Emitter Program. Specifically, it will be the EPA, not third parties, that will notify owners and operators of super-emitter events after reviewing third-party notifications. Further, the EPA will only accept data submitted by EPA-certified third parties and collected using EPA-approved technologies. Upon receiving data submitted by a certified third party, the EPA will review the data for completeness and accuracy; the EPA will post such data and notify the identified owner or operator only after it has reviewed and deemed the information to be complete and accurate. Accordingly, the EPA plays a central role at every step: certifying (and de-certifying) the third parties who will be able to submit notifications under this program, approving the technology such parties may use, reviewing the notifications to ensure the information therein is accurate and complete, notifying owners and operators of such information, receiving and reviewing responses from owners and operators, and determining when to post information and responses publicly.

The final Super Emitter Program sets forth criteria that a third party must meet in order to be certified to submit data on super-emitter events to the EPA. These criteria ensure that the data submitted to the EPA are collected by a qualified third party with access to an EPA-approved technology and the technical expertise and capability to use such technology to detect and collect data on super-emitter events. The final rule also lists circumstances under which a third-party certification will be revoked, such as repeated submissions of data with significant errors, or engagement in an unlawful action (*e.g.*, trespass) when monitoring for super-emitter events.

Upon receiving data submitted by a certified third-party, the EPA will review the data for completeness and accuracy; the EPA will post such data and notify the identified owner or operator only after it has reviewed and deemed the information to be complete and accurate.

As finalized, the Super Emitter Program does not “delegate” any regulatory or enforcement role to third

³¹⁰ Id. at 74752 (“[T]he EPA believes that super-emitter emissions events from unintentional releases tend to occur as a result of equipment malfunctions and/or poor operations; therefore, the BSER for super-emitter emissions events would be to correct the malfunction or operational issues and resume normal operations consistent with the standards or requirements applicable to the source(s) of the super-emitter emissions event in this proposed rule.”).

³¹¹ EPA-HQ-OAR-2021-0317-2428.

³¹² Please see X.C of the preamble for a detailed discussion on this legal framework.

parties. Rather, the Super Emitter Program merely serves as a mechanism for the EPA to receive reliable data on super-emitter events from qualified third parties with access to and expertise in using EPA-approved advanced technology to detect super-emitter events. The Super Emitter Program also provides a structured process for the EPA to use that data to notify the owner or operator of a regulated facility of the existence of a super-emitter event that may indicate a lapse in compliance at the facility, or a source of fugitive emissions that this rule requires to be promptly repaired. There is no sense in which this framework “delegates” governmental authority of any kind to any third party. No action is required of an owner or operator solely on the basis of an action of a third party. In addition, the process by which the EPA receives data and issues notifications under the Super Emitter Program is separate from and unrelated to the EPA’s enforcement functions.

This structure, where the EPA reviews and determines the reliability of reported data on super-emitter events, is similar to other, longstanding programs where citizens and other entities can report concerns about regulatory compliance to the Agency. For example, the EPA’s Office of Enforcement and Compliance Assurance administers a program where citizens and other entities can report suspected environmental violations. See <https://echo.epa.gov/report-environmental-violations#:~:text=Stop,Stop,%2D80%2D424%2D8802>. The Super Emitter program likewise functions to allow third parties to share with the EPA monitoring data, and then allows the EPA to determine the reliability of the data, and engage with the relevant, regulated party to determine if there is a need for further action to ensure compliance with the EPA’s regulations. The third parties reporting super-emitter events do not have an independent enforcement role as a function of the Super Emitter Program. Instead, the EPA retains its traditional enforcement authority.

As explained in the December 2022 Supplemental Proposal (87 FR 74752) and noted by one commenter,³¹³ the Super Emitter Program serves as a backstop to addressing emissions from super-emitter events that were not prevented from other requirements in the rule. However, the EPA did not propose and does not require in the final program any specific investigation to be conducted to identify the source

of the super-emitter event. Because the relevant investigations for identifying the source(s) of the super-emitter event may vary depending on what the third-party data reveals, the final rule defers to the owner and operator in deciding the appropriate investigation(s). However, where there are NSPS affected facilities (or designated facilities subject to a state or Federal plan implementing EG OOOOc) or associated equipment onsite, the owner and operator may conclude that they are unable to identify the source of the super-emitter event only after having conducted the applicable investigation listed in the final rule for such regulated source.

The EPA further notes that the obligation to investigate and report the source of super-emitter events (separate and apart from the obligation to take steps to address the super-emitting event) is not limited to NSPS affected facilities (or designated facilities subject to a state or Federal plan implementing EG OOOOc) and associated equipment; it also extends to other equipment onsite that an owner and operator suspects could be the source of a super-emitter event. As one commenter observes, the EPA has broad authority to require emissions reporting under CAA section 114(a). Among other things, CAA section 114(a) authorizes the EPA to require “any person who owns or operates any emission source” (except mobile sources)³¹⁴ to provide information necessary for purposes of carrying out the CAA. In this case, section 114(a) authorizes the EPA to require the reporting of information on super-emitter events, so that the EPA may evaluate whether such large emissions can be adequately addressed under the EPA regulations to date or whether more needs to be done in the future (e.g., during the next periodic review of the NSPS under CAA section 111). Therefore, the EPA expects the owner and operator to investigate all equipment onsite that they suspect could be the source of a super-emitter event, whether or not such equipment is subject to NSPS regulation or a state or Federal Plan implementing EG OOOOc. Where the super-emitter event was caused by equipment not subject to NSPS OOOO, OOOOa, or OOOOb, or a state or Federal plan implementing EG OOOOc, the owner and operator must report such finding. However, there is no requirement for the owner or operator to take action to eliminate or mitigate the emissions from the super-emitter event caused by sources not

subject to an NSPS or a state or Federal plan implementing EG OOOOc.

While there are comments expressing concerns with the proposed program as described above, the EPA received comments expressing strong support for the program from several states,^{315 316} environmental groups³¹⁷ and industry.^{318 319} One industry commenter concurs with the EPA on the importance of identifying and addressing large emissions events and shares the EPA’s interest in seeking to reduce the incidence of such large emissions events. The commenter also agrees with the EPA that data transparency is valuable and shares the EPA’s goal of disseminating information to mitigate emissions events. The EPA believes that the final Super Emitter Program, which has been significantly revised in response to comments, will serve its goal of reducing emissions from super-emitter events that were not prevented by other requirements in the rule.

2. Certification of Third Party

This section of this document presents a summary of significant comments received on certification of third-party notifiers as part of the Super Emitter Program and the EPA’s response to those comments, as well as changes the EPA has made to the requirements since the December 2022 Supplemental Proposal.

The EPA received many comments regarding how advanced methane detection technology has been incorporated into our proposed standards, including the lack of clarity on which remote sensing technology would be considered for the program, how the remote sensing technology could be considered for the program, what an approval process could look like, and how best to make this program transparent.

Comment: Several commenters^{320 321} expressed concern with the lack of standard methods for the example technologies that the EPA identified in the proposed rule as compared to test method requirements (i.e., validated test methods) that underpin compliance determinations for NSPS or national emissions standards for hazardous air pollutants (NESHAP) standards. One of these commenters suggested that the proposed programmatic requirements (i.e., alternative test methods) be

³¹⁵ EPA–HQ–OAR–2021–0317–2296.

³¹⁶ EPA–HQ–OAR–2021–0317–2422.

³¹⁷ EPA–HQ–OAR–2021–0317–2433.

³¹⁸ EPA–HQ–OAR–2021–0317–2428.

³¹⁹ EPA–HQ–OAR–2021–0317–2499.

³²⁰ EPA–HQ–OAR–2021–0317–2366.

³²¹ EPA–HQ–OAR–2021–0317–2483.

³¹⁴ The EPA has similar information collection authority with respect to mobile sources under CAA section 208.

³¹³ EPA–HQ–OAR–2021–0317–2433.

applied to the Super Emitter Program. Another of these commenters recommended that the EPA develop guidance on test and monitoring methods to use to define super-emitter emissions events.

Several commenters^{322 323} urged the EPA to not overly restrict the technologies that may qualify and suggested that the EPA should use the alternative test method approval process already under development to approve advanced methane detection technologies for monitoring fugitive components, covers, and closed vent systems in this rule for use in the Super Emitter Program. One of these commenters provided that such an approach could allow for additional technologies that could operate within the requirements of this program. Another commenter urged the EPA to use the already proposed alternative test method to remove any potential barriers on the third party to evaluate technology and to bring the measurement to the same level as that of the owner or operators while improving objectivity.

Some commenters^{324 325} raised safety concerns regarding individuals engaged in third-party monitoring. One of these commenters raised concerns that certain monitoring technologies used by third parties to identify super-emitter emissions events that need to be operated in the close vicinity of a site, and that individuals conducting that monitoring may not be aware of important safety concerns regarding that site. Another one of these commenters provided examples of such safety concerns associated with members of the public accessing sites without proper notice. For example, some sites can contain hydrogen sulfide (H₂S), a gas that could result in serious health impacts for members of the public entering a site without proper protection. The commenters raised concerns that individuals may not be aware of such hazards or have the appropriate personal protection equipment (PPE) and training to mitigate them.

Response: Regarding the comments on the use of remote sensing technology and the lack of approved or validated methods for use in the Super Emitter Program, we agree with the commenters that the remote-measurement approaches used for this program should be evaluated in the same manner as any compliance measurement used in

this rule. The EPA also agrees with the commenters' recommendations that we use the alternative test method approval process already under development to approve advanced methane detection technologies for monitoring fugitive components, covers, and closed vent systems in this rule. Therefore, in the final rule we are requiring that third parties participating in the Super Emitter Program use an alternative test method that has been approved under 40 CFR 60.5398b(d) of the final rule and we have revised the scope of the alternative test method program to now include the approvals for the Super Emitter Program.

Comment: Several commenters^{326 327} ask that the EPA clarify its intent as to which advanced methane detection technologies can be utilized for the Super Emitter Program. Several commenters^{328 329} maintained that the EPA must provide a clear pathway for communities and third parties to participate and engage in the Super Emitter Program. They also said that the EPA must ensure that data from approved monitoring technologies are accessible to all, including by allowing the use of OGI cameras in this program. These commenters urged the EPA to expand what they characterized as the overly restrictive technology standards proposed for the Super Emitter Program, which would currently work to limit the participation of NGOs and communities that lack access to remote detection technologies.

Response: In the December 2022 Supplemental Proposal, the EPA identified satellites, aircraft, and other mobile monitoring measurement systems that can quantify an emission rate of 100 kg/hr of methane or greater. These examples were intended to make clear that third parties would only use technology that could be used at a reasonably safe distance, well away from a well site, central tank battery, or compression station, to ensure the integrity of these sites and the safety of the individuals or organizations collecting the measurements. Nothing in this rule should be construed as authorizing third parties to enter well sites or any other affected facility or designated facility to take measurements. Also, we recognize that mobile monitoring platforms could be interpreted broadly; this language is the EPA's effort to account for the continuing advancement of methane detection technology, and the

qualification to meet the mobile monitoring platform is that we would allow any un-fixed measurement technology operating offsite from a well site, central tank battery, or compression station that can quantify an emission rate of 100 kg/hr of methane or greater. For the final rule, the EPA is maintaining the proposed criteria regarding which measurement technologies can be used in the Super Emitter Program. While the minimum threshold remains 100 kg/hr, the EPA would consider the use of remote technologies with higher detection thresholds in this program. However, those technologies would be limited to reporting emissions events above their detection threshold.

Lastly, we acknowledge the desire of certain third-party groups to use OGI as part of this program. However, the current generation of this technology does not have the quantification ability required as part of this rule. More importantly, this technology cannot be operated at a distance and creates more potential for users getting too close to the site and creating risks to themselves or to the site. We recognize that a number of the technology vendors focusing on OGI are developing systems capable of quantification, and as these systems come online, this determination may change if there is a mechanism to ensure that the monitoring is only done at a reasonable and safe distance away from an applicable well site, central tank battery, or compression station.

The EPA further notes that direct monitoring is not the only way that communities can participate in or benefit from the Super Emitter Program. The EPA anticipates that a broad range of entities, including community organizations that are not themselves certified, might partner with a certified third party to identify locations of particular concern for monitoring attention. The EPA will also be posting the super-emitter event data shortly after it is received, which provides communities with information that could be relevant to local health and air quality, and could also be useful to communities seeking to advocate on their own behalf.

Comment: Several commenters^{330 331} raised concerns that the December 2022 Supplemental Proposal offered little clarity about the necessary demonstrated expertise for third parties. Many of these commenters also stated that the EPA should develop detailed criteria for the certification of these third-party notifiers. Furthermore,

³²² EPA-HQ-OAR-2021-0317-2410.

³²³ EPA-HQ-OAR-2021-0317-2394.

³²⁴ EPA-HQ-OAR-2021-0317-2326.

³²⁵ EPA-HQ-OAR-2021-0317-2360.

³²⁶ EPA-HQ-OAR-2021-0317-2249.

³²⁷ EPA-HQ-OAR-2021-0317-2410.

³²⁸ EPA-HQ-OAR-2021-0317-2394.

³²⁹ EPA-HQ-OAR-2021-0317-2410.

³³⁰ EPA-HQ-OAR-2021-0317-2399.

³³¹ EPA-HQ-OAR-2021-0317-2403.

according to another commenter,³³² the Agency should make transparent and publicly disclose what other qualified parties have been certified. Some commenters raised a concern that some third-party notifiers may be inadequately trained to detect methane leaks; these same commenters recommended that third-party notifiers be required to have appropriate training/certification to validate emissions events. Another commenter stated that a third party must complete an approval certification process by the EPA for inclusion in the Super Emitter Program; also this commenter suggested that third parties notify the EPA of planned monitoring, including submittal of a monitoring plan.

One commenter³³³ questioned how effectively a third party would be able to identify an owner or operator of a site or be able to contact the right people if the facility is covered by NSPS OOOOb. The same commenter mentioned the importance for notifications to be sent to the correct person at the operating company. Another commenter³³⁴ agreed that the qualifications of third-party reporters are important and that approved third-party reporters should show proficiency and accuracy in identifying super-emitter leaks.

Several commenters³³⁵⁻³³⁶ provided recommendations on how to improve the process for revoking certifications for third parties. A few of these commenters argue that the three-time threshold for inaccurate event notifications from a third party is too high and should not be limited to multiple notifications at the same facility owned by the same operator. Another commenter³³⁷ recommended that the criteria for revocation explicitly state that revocation would occur upon a third party's third submission of verifiably false data from any combination of operators or sites, or upon trespass or otherwise unlawful or unauthorized entry to a facility.

Response: The EPA agrees with the commenters that the final rule should more completely define the certification process and criteria these third parties must meet. Therefore, in the final rule we have amended the regulatory text to include the procedures an entity must follow when seeking certification, what information they must submit to the EPA as part of this certification process, and a set of standards an approved

third-party notifier must continue to follow.

The final rule now provides direction for any entity requesting certification to be a third-party notifier to submit the required information to the Leader, Measurement Technology Group, Mail Drop: E143-02, 109 T.W. Alexander Drive, P.O. Box 12055, Research Triangle Park, NC 27711. The required submission information includes general information on the organization requesting the certification, qualifications for the certifying official, which measurement technologies will be used, standard operating procedures for data review, records management processes, and a Quality Management plan. The required information is not intended to be onerous, however these basic requirements are consistent with the EPA's internal data review process and are in place to ensure that notifications being provided to the EPA are actionable and accurate. We are also requiring third-party notifiers to maintain the relevant records from surveys conducted or sponsored by the third party, including data used to evaluate the validity of a super-emitter event but which is not required to be submitted as part of the notification.

In addition, the final rule defines the Administrator's authority to approve or disapprove certifications as a third-party notifier, clarifies when third parties must be certified, and provides greater detail on the process to revoke certifications. The EPA agrees with commenters' points that the program should be run transparently, and the identification of all certified third-party notifiers shall be posted on the EPA website at <https://www.epa.gov/emc-third-party-approvals> with a corresponding third-party notifier ID. The EPA disagrees with the comment that third parties must be recertified at a specific frequency; instead, the final rule requires third parties to amend their certification (*i.e.*, recertification) to account for any significant changes in their technology or other elements of their certification. The EPA considers it important to require third parties to amend their certification to account for the advancement in the methane detection technology and will structure the program to quickly evaluate these amendments.

Finally, the EPA agrees with the commenters that the Agency should expand the circumstances in which a third party can be removed from the list of approved notifiers. With the EPA's central role in handling super-emitter notifications, we have expanded the circumstances to include removal of a third party that has made material

changes to their process without amending their certification, if a certified third-party notifier has repeatedly submitted data with significant errors, or if the third-party notifier engages in an illegal activity during the assessment of a super-emitter event (*e.g.*, trespassing). We are also finalizing the proposed provision that the Administrator revoke a certification upon receiving a petition from an owner or operator documenting that it has received three or more notices with materially erroneous information on a super-emitter event at the same well site, centralized production facility, or compressor station, submitted to the EPA by the same third-party notifier. Since the 2022 Supplemental Proposal, the EPA has improved the robustness of the Super Emitter Program by establishing specific and detailed criteria to ensure the qualifications of third parties who can be certified and the quality and accuracy of the data that the EPA will accept from the certified third parties; further, the EPA will review the submitted data for completeness and accuracy before issuing any notice of a super-emitter event to an identified owner or operator. The EPA believes that these safeguards will minimize, if not eliminate, issuance of clearly erroneous notices; however, there may be errors in the submitted information that cannot be readily discerned by the third-party notifier or the EPA, at least not without more time, which would undermine the Program's objective to provide owners and operators timely information to identify and address super-emitter events. In light of the above, the EPA believes that revoking a third-party's certification after three times of submitting data with material errors on the same facility is an appropriate balance between providing owners and operators timely notifications of super-emitter events at their facilities and minimizing the likelihood and therefore burden of owners and operators having to respond to notices with material erroneous information.

3. Notifications by the Third Party and Requirements

We received several comments on ways to improve the notification process in the Super Emitter Program. This section of this document presents a summary of significant comments received on the handling of notifications and the EPA's response to those comments, as well as changes the EPA has made to account for those comments, including a central role for the EPA in collecting and reviewing

³³² EPA-HQ-OAR-2021-0317-2428.

³³³ EPA-HQ-OAR-2021-0317-2406.

³³⁴ EPA-HQ-OAR-2021-0317-2216.

³³⁵ EPA-HQ-OAR-2021-0317-2428.

³³⁶ EPA-HQ-OAR-2021-0317-2168.

³³⁷ EPA-HQ-OAR-2021-0317-2446.

third-party reports of super-emitter events and providing notifications.

Comment: Several commenters^{338 339} expressed that super-emitter data should be published by the EPA and that the EPA should manage all data that is to be public and establish a protocol for when and what types of specific details of a potential super-emitter emissions event are published. Another commenter suggested that the EPA should maintain a public database of all super-emitter notifications by certified third-party reporters. Still another commenter strongly disagreed that the EPA should promptly make such reports available to the public online and recommended that the EPA should provide time to verify or authenticate the information from third parties and allow owners or operators to review and respond to the information.

Several commenters³⁴⁰ stated that notifiers should be required to provide proof of the event such as time, date, location, and visual evidence of leak origin. One commenter³⁴¹ said that the EPA should show discretion in accepting information provided by third parties as proof that a super-emitter exists, including quantification of the super-emitter. Still other commenters³⁴² were concerned that the notifications are based on a snapshot in time, which they asserted was not sufficient, and that the EPA should establish criteria for the third party to demonstrate that excessive rates of methane are occurring for an extended period of time.

Several commenters^{343 344 345} expressed concern that the December 2022 Supplemental Proposal did not state the amount of time required for notifications following the detection of a super-emitter. Many of these commenters discussed how the time required may be dependent on the type of remote sensing technology, the ability to identify the relevant operator, and the capabilities of the third-party notifier. In these individuals' comments, the commenters provided a range of potential suggested requirements for providing notifications, from 1 day to a few weeks. Some of these commenters identified that timely notification would lead to earlier mitigation, but more importantly that some of these super-emitter events are intermittent and investigation into their cause is more

effectively performed closer to the event and would aid in prevention. An additional commenter³⁴⁶ raised concern that information received several months after a detection will likely be challenging for operators to utilize effectively.

Finally, one commenter³⁴⁷ suggested that third parties should attest that the notifier is an EPA-approved entity for providing the notification and that the information was collected and interpreted as described in the notification. The commenter went on to explain that a signed certification provides fidelity to the requirement that the information is coming from a verified source. The commenter believes that this can be in the form of a weblink that traces back to the EPA's website hosting the list of third-party notifiers.

Response: The EPA agrees that the program will be more effective with the EPA in a centralized role to accept and review third-party submittals and make the notifications to an owner or operator in a timely manner, and so we are revising the final rule to include a substantial oversight role for the EPA. The EPA also agrees with those commenters who assert that it is important that these data should be public, and to address these comments, the EPA is developing a Super Emitter Program Portal to be found at the following URL, <https://www.epa.gov/super-emitter>. The Portal will serve to manage the data associated with the Super Emitter Program, including data coming into the system from EPA-certified third parties, providing notifications from the EPA to affected owners or operators, responses back from the owner or operators, and display of the super-emitter data. This portal and the underlying data management system from which it is built will allow the EPA to quickly review incoming data for accuracy and completeness, allowing for timely notification of verified data to owner or operators.

The EPA does not agree with the commenters that verified data should not be public until such time that an owner or operator has a chance to review and respond to the information, and the EPA believes it is important that this program is operated transparently. However, the EPA is conscious of these commenters' concerns that many of the oil and gas basins are dense with sites and that uncertainty in the spatial resolution of some of the remote sensing platforms may make correct identification of the owner or operator

challenging. Therefore, the EPA will not identify the attribution of the super-emitter source until the notified owner or operator of a site has the opportunity to respond; this will be further discussed later in this section.

The EPA agrees with those commenters that the third-party notifiers must be able to provide proof of a super-emitter event and therefore the final rule has defined the information that must be submitted by the third party into the Super Emitter Program Portal. Only those individuals and organizations that have been certified will be able to access the notification portion of the portal. The required information that must be supplied with the notification are the: third-party notifier ID; date of detection of the super-emitter event; location in latitude and longitude; owner, or operator of a well site within 50 meters of the identified latitude and longitude, if available; detection technology used; documentation (*e.g.*, imagery) of the super-emitter event and from which it is detected; quantified emission rate; and associated uncertainties. The EPA also agrees with those commenters that the EPA super-emitter data must be supplied in a timely manner and therefore in this final rule we are requiring that notifications must be supplied to the EPA within 15 days after the detection event; we believe this is a reasonable amount of time within which to acquire the data, verify the data, and identify an owner or operator, consistent with the importance of quick notification. In the final rule, to ensure that the EPA is providing actionable information to the owners or operators, the EPA will not review and/or provide any notifications to an owner or operator unless the third-party notification is received within 15 days after detection of the super-emitter event. Furthermore, the EPA agrees that a third party must attest to the accuracy of their notification and in the final rule we now include an attestation statement to be signed by the certifying official.

Information that is received within 15 days after detection and is attested, complete, and found to be accurate to a reasonable degree of certainty will be assigned a unique notification number, provided to the identified owner or operator as quickly as possible, and the notification will be made public at <https://www.epa.gov/super-emitter> at the same time. However, the initial public notification will not include the identity of the owner or operator, so that the notified owner or operator has an opportunity to respond before attribution is posted.

³³⁸ EPA-HQ-OAR-2021-0317-2409.

³³⁹ EPA-HQ-OAR-2021-0317-2399.

³⁴⁰ EPA-HQ-OAR-2021-0317-2453.

³⁴¹ EPA-HQ-OAR-2021-0317-2399.

³⁴² EPA-HQ-OAR-2021-0317-2483.

³⁴³ EPA-HQ-OAR-2021-0317-2202.

³⁴⁴ EPA-HQ-OAR-2021-0317-2301.

³⁴⁵ EPA-HQ-OAR-2021-0317-2409.

³⁴⁶ EPA-HQ-OAR-2021-0317-2221.

³⁴⁷ EPA-HQ-OAR-2021-0317-2428.

4. Requirements for Owners and Operators

We received several comments on the December 2022 Supplemental Proposal on the required actions when owners or operators receive notification of a super-emitter event as part of the Super Emitter Program. This section of this document presents a summary of significant comments received regarding the follow-up investigations, requirements for any necessary repairs, and reporting the results of those investigations to the EPA, and the EPA's response to those comments. This section also details changes the EPA has made in the final rule to account for those comments, changes in the final rule concerning the EPA's central role in handling responses from the owner or operator, and changes in the final rule reflective of this program as a compliance assurance program.

We received several comments^{348 349 350} supporting the requirement that owners or operators investigate the source and cause(s) of significant emissions events that are brought to an operator's or owner's attention. More than a few of these commenters took issue with our proposed use of "root cause analysis" for investigating potential causes of super-emitter events. Specifically, one comment argued that the concept of "root cause analysis" is embedded in numerous other regulatory and non-regulatory programs and has varied meaning and purpose in each application, and another commenter asserted that the phrase "root cause analysis" has connotations that lead to a much more involved process than the EPA appears to have envisioned in the December 2022 Supplemental Proposal. Many of these commenters suggest that "root cause analysis" be replaced by "investigative analysis," broadly meaning the owner or operator must determine whether an emissions event has occurred and take steps to ensure that it will not happen again.

We received several comments discussing the suitability of the timelines provided in the December 2022 Supplemental Proposal. Several commenters^{351 352} indicated the proposed 5 days to initiate root cause and 10 days to complete corrective action are inadequate, as some locations are remote in nature or, in some instances, may require longer timeframes to obtain equipment or

schedule service companies to complete the corrective action. Some of these commenters recommended that the EPA provide owners or operators with 14 business days to conduct an analysis of the incident and provide the EPA with recommended actions to avoid future occurrences; one commenter also suggested that if analysis cannot be conducted within 14 business days, the owner or operator should notify the EPA and let the Agency know when the analysis will be available, which in no event may exceed 90 days.

The EPA also received several comments regarding the potential causes for super-emitters and what the appropriate steps should be for investigating super-emitter events. One commenter³⁵³ reasoned that many of the super-emitter events of this magnitude are caused by unlit flares and tank malfunctions and that in those cases owners and operators should be able to fix the underlying issue quickly. Another commenter³⁵⁴ identified that super-emitter emissions may be caused by an anticipated, short-duration event such as operations and maintenance activity at the site. Several commenters^{355 356} raised that for sites with validated continuous monitoring systems, these systems will very likely already have noted and mitigated super-emitter events before even receiving a notification.

Regarding whom is subject to the Super Emitter Program, the EPA received some comments that no investigative analysis should be required if the emissions are not associated with an affected facility under NSPS OOOOb. Another commenter³⁵⁷ contends that the EPA has broad authority under CAA section 114 to accept and use third-party monitoring data for purposes related to CAA section 111, including ensuring compliance.

The EPA received several comments on how best to manage super-emitter event reporting after receipt of a super-emitter notification. A commenter³⁵⁸ explores the possibility that an owner or operator should only be reporting to the EPA when the facility owner or operator confirms the super-emitter event; this commenter also discussed the EPA's developing a document repository for the notices to operators it receives as well as the reports sent by the owners and operators in response. A few

commenters^{359 360} representing state and Tribal authorities request that all subsequent reports and submittals should also be copied to the state, to aid states' compliance efforts under the Super Emitter Program and to provide information that states can use in their own compliance and enforcement efforts. Several commenters raised concerns regarding either the misidentification of an operator's facility or inaccurate quantification of super-emitter emissions. Another commenter requested that we maintain the language referenced in the December 2022 Supplemental Proposal preamble to allow that owners and operators would have the opportunity to rebut any information in a notification provided by the qualified third parties in their written report to the EPA, by explaining where appropriate that: there was a demonstrable error in the third-party notification; the emissions event did not occur at a regulated facility; or the emissions event was not the result of malfunctions or abnormal operation that could be mitigated.

The EPA is finalizing the Super Emitter Program as primarily a compliance assurance program and is not maintaining the root cause analysis and corrective action requirements from the December 2022 Supplemental Proposal. The EPA acknowledges the commenters' concern with the use of the ambiguous root cause and corrective action language for this sector and is in the final rule defining a set of investigations that an owner or operator must perform when provided with a super-emitter notification. The EPA is maintaining the requirement from the supplemental proposal that the owner or operator of a well site, centralized production facility, or compressor station must initiate an investigation within 5 calendar days after a notification, and based on comment we are extending the period to conduct the investigation to 15 calendar days. These time periods are appropriate given the very large emissions associated with super-emitter events; it is important that owners and operators respond quickly to these very large emissions events and take immediate action to stop them. Many operators have noted to the EPA that prompt notice of super-emitter events is important to them exactly for this reason.

The EPA has defined a series of required investigations in the final rule, designed to target these very large emissions events as part of a compliance assurance program. In response to

³⁴⁸ EPA-HQ-OAR-2021-0317-2627.

³⁴⁹ EPA-HQ-OAR-2021-0317-2483.

³⁵⁰ EPA-HQ-OAR-2021-0317-2326.

³⁵¹ EPA-HQ-OAR-2021-0317-2305.

³⁵² EPA-HQ-OAR-2021-0317-2409.

³⁵³ EPA-HQ-OAR-2021-0317-2433.

³⁵⁴ EPA-HQ-OAR-2021-0317-2326.

³⁵⁵ EPA-HQ-OAR-2021-0317-2284.

³⁵⁶ EPA-HQ-OAR-2021-0317-2333.

³⁵⁷ EPA-HQ-OAR-2021-0317-2433.

³⁵⁸ EPA-HQ-OAR-2021-0317-2193.

³⁵⁹ EPA-HQ-OAR-2021-0317-2241.

³⁶⁰ EPA-HQ-OAR-2021-0317-2177.

comments, the investigations are designed to minimize the time and resources associated with conducting these investigations. Upon receiving a super-emitter notification by the EPA, a recipient is first required to determine if it is the owner or operator a well site, centralized production facility, or compressor station within a radius of 50 meters from the latitude and longitude provided in the notification, and if not, the recipient's investigation is complete. If the recipient does own a well site, centralized production facility, or compressor station within a 50-meter radius, it must determine the applicability of any equipment under 40 CFR part 60, subpart OOOO, OOOOa, or OOOOb, and/or a state or Federal Plan implementing subpart OOOOc, and is required to perform the investigations as defined in that applicable subpart. However, for ease of use, the investigations in each of these subparts are identical. We agree with the commenters that the largest potential for super-emitters is from maintenance events and failure of controls and, as such, have incorporated elements into the investigations under the requirements for maintenance and controls to identify potential causes. Specifically, the investigation incorporates the review of any maintenance events (*e.g.*, liquid unloading) conducted from the date of detection until the start date of the investigations; and the review of process monitoring data (*e.g.*, SCADA systems) from control devices to identify any potential causes of a super-emitter event. We also agree with the commenters that methane monitoring surveys and/or continuous emissions monitoring conducted from the date of detection until the start date of the investigations would have identified the presence or absence of a super-emitter event and when an event is identified the owner or operator could quickly identify the cause(s). All these investigations are designed to leverage actions potentially being performed or recorded as part of daily operation of a site and are effective tools for identifying large emissions events. The EPA also recognizes that all sites will not have continuous monitoring systems and that the owner or operator is likely not to have conducted fugitive monitoring between the date of detection and the notification; in those events we are requiring the owner or operator to conduct screening for a super-emitter event using either OGI, EPA Method 21, or an approved alternative test method(s) approved per 40 CFR 60.5398(d).

The EPA has restructured the reporting requirements for owners and operators in the final rule to be consistent with the change in the program to focus on compliance assurance and to account for the revised investigation requirements in the rule. While some commenters suggested that only confirmed super-emitter events should require reports, it is important for an owner or operator to report the results of their investigation in any case, as the absence of a super-emitter event is equally as important as the confirmation for the EPA, the state, local, or Tribal authority, and the general public. As such, we are requiring any owner or operator who receives a notification to report the finding of their investigation. The EPA agrees with these comments requesting that these owner or operator super-emitter reports be readily accessible, so the EPA is requiring that these reports be submitted through the Super Emitter Program Portal to aid in the public display of data. The EPA also agrees with those state and Tribal authorities that super-emitter reports should be available to the states at the time of reporting, and the Super Emitter Program Portal will include a function to notify a state, local, or Tribal authority when notifications and/or reports from their jurisdiction are received. The EPA is requiring that owners or operators report the findings within 15 days after receiving a notification of a super-emitter event; this marks the final day of the investigation period and is a timeline that is consistent with criteria in the December 2022 Supplemental Proposal for reporting initial corrective action. We acknowledge that we received comment from industry requesting longer timelines for corrective actions. Due to the large size of these emission events, the EPA considers the 15 days requirements a reasonable timeframe within which to conduct and report the required investigations to determine if the emission event is ongoing is consistent with the objective of this program to provide actionable information to owners or operators of facilities experiencing large emissions events, so they can investigate and perform repair if needed. The super-emitter program does not place any additional requirements or timeline to repair (*i.e.*, corrective actions) the source of these large emission events that are not already included in the rule, however the final rule does include reporting requirements if the emission events are ongoing at the time of the initial report submittal.

The level of reporting required by the owner or operator is dependent on the results of the investigation and the super-emitter event. The owner or operator of a site within 50 meters from the latitude and longitude in the notification is required to provide the super-emitter event notification ID, general identification of the facility, whether the equipment on the site is subject to regulation under the applicable subpart, and whether you were able to identify the super-emitter event. If the owner or operator is able to identify a super-emitter event, the owner or operator would also report if the equipment was subject to an applicable regulation (including the applicable subpart), whether or not the super-emitter event is ongoing at the time of reporting, and, if the super-emitter event is not ongoing at the time of reporting, the actual or estimated date and time when the event ended. If the super-emitter event is ongoing at the time of reporting, the owner or operator would provide a short narrative of the plan to end the super-emitter event, including an expected end date of the event, and the owner or operator would be required to update the initial report within 5 days after the actual end date of the super-emitter event.

Finally, we acknowledge the commenters' concerns that a third party may either misidentify a site's owner or operator or provide inaccurate data, and we agree with the commenters that owners and operators should have the opportunity to refute the information provided by the third party. The revised program in this final rule will give the owner or operator the opportunity to respond before the emissions event is attributed to a particular owner or operator, through posting of the report that the owner or operator submits to the EPA through the Super Emitter Portal.

5. Recordkeeping and Reporting Requirements for Process Controllers Not Included in the Affected Source

Comment: Commenters pointed out that 40 CFR 60.5420b(b)(7) requires owners and operators to submit an identification of all process controllers that are not powered by natural gas in the initial annual report, and such controllers are not covered by the definition of the affected facility for process controllers for NSPS OOOOb. The commenters recommended that owners or operators only be required to maintain records and submit information sufficient to determine compliance with the regulations. The commenters contend that having requirements for equipment that is not

part of an affected facility exceeds the EPA's authority granted under CAA section 111 and add that there is no environmental benefit to keeping or submitting information for equipment that cannot have emissions. The commenters recommended that the EPA delete any reporting or recordkeeping requirements for these controllers from the final regulations.

Response: After considering this comment, we have determined that it is appropriate in this instance to require identification of the equipment that is included in the affected facility, rather than the equipment that is not part of the affected facility. The process controllers included in the affected facility are those that are subject to the emissions standards, whereas process controllers not included in the affected facility are not subject to the emissions standards in the final rule and also mostly have no potential to emit methane or VOCs. Therefore, we have revised the recordkeeping requirements to require identification only of controllers that meet the finalized definition of an affected facility, which are those process controllers that are driven by natural gas and that are not ESDs.

D. Process Controllers

Process controllers are among the largest sources of methane and VOC emissions in the source category. In the December 2022 Supplemental Proposal, the EPA proposed for both the NSPS OOOOb and EG OOOOc to define the process controller affected facility, and designated facility, as the collection of all natural gas-driven process controllers at a site. The December 2022 Supplemental Proposal, like the November 2021 Proposal, proposed two different standards for process controllers. For affected facilities that are not located in Alaska, the EPA proposed a zero-emissions standard and explained that it could be achieved with any one of several available technology options that many owners and operators are already deploying to varying degrees, including the use of electric controllers or compressed air systems (powered by the grid or by an onsite generator), solar-powered controllers, and natural gas-driven controllers that are self-contained or that are routed to a process. For affected facilities that are located in Alaska and do not have access to grid power, the EPA proposed a low-bleed emissions standard for continuous vent process controllers and a requirement that intermittent process controllers be periodically monitored for leaks and malfunctions using OGI.

A number of comments were received on aspects of the proposed NSPS OOOOb and EG OOOOc zero-emissions standard. This included comments on the costs and emissions estimates that supported the BSER analysis. These comments and the EPA responses are provided in section XI.D.1 of this document. The EPA received other comments related to the zero-emissions standard, including comments regarding access to reliable electricity and the technical feasibility of solar-powered controllers, routing emissions from natural-gas driven controllers to a control device, the potential impacts on small businesses, and the secondary emissions from the use of onsite generators. These comments and the EPA's responses are provided in section XI.D.2 of this document. Section XI.D.3 summarizes the refreshed BSER analysis and conclusions for the final rule. Comments were received regarding the compliance dates for both the NSPS and the EG. These comments and the EPA's responses are provided in section XI.D.4 of this document. The EPA also received comments regarding proposed recordkeeping and reporting requirements for process controllers not included in the affected facility and the criteria that would determine whether a process controller was modified or reconstructed. These comments, along with the EPA responses and the resulting rule changes, are provided in sections XI.D.5 and D.6 of this document. The EPA's full response to comments on the November 2021 Proposal and December 2022 Supplemental Proposal, including any comments not discussed in this preamble, can be found in the EPA's RTC document for the final rule.³⁶¹

In addition to the changes made to the final NSPS and EG to address these comments, one other change in terminology was made to address confusion in comments related to the types of equipment that may be used to perform the functions of process controllers. That change is discussed in section XI.D.7 of this document.

1. BSER Cost Analysis

As described in the December 2022 Supplemental Proposal,³⁶² the EPA reviewed a range of technologies (control options) for limiting or avoiding

GHG (methane) and VOC emissions from process controllers. The EPA concluded that adequately demonstrated zero-emissions pneumatic controller systems were available throughout the production and the transmission and storage segments. To evaluate the costs of these systems, the BSER analysis for the December 2022 Supplemental Proposal was performed for three model plant sizes in both the production and the transmission and storage segments. These model plant sizes were based on the number of natural gas-driven pneumatic controllers at a site: 4 controllers for the "small" model plant, 8 controllers for the "medium model plant," and 20 controllers for the "large" model plant. For new sources, these controllers were broken down by low-bleed and intermittent vent. For existing sources, there was also one high-bleed controller for each model plant size. The zero-emissions options analyzed for each model plant were: electric controllers powered by the grid, electric controllers powered by solar energy, compressed air systems powered by the grid, and compressed air systems powered by an onsite generator. As a result, the EPA's cost analysis considered sites both with and without electrical service (grid power). Based on this analysis, the EPA concluded that there was at least one option for each model plant size with a cost effectiveness value that is within the range the EPA considers to be reasonable for the purposes of this rulemaking.³⁶³

The EPA received and considered comments that resulted in updates to its cost analysis. These updates focused on model plants as well as the capital recovery periods for several options, and the option of using a generator to power electric controllers at sites without grid electricity was added. Each of these issues is discussed in more detail below.

Comment: One commenter³⁶⁴ recommended that the EPA gather additional information to create a representative gathering and boosting compressor station model plant. They indicated that gathering and boosting compressor stations typically have many more than 20 controllers and require air compressors larger than 20 horsepower, as the EPA assumed in the "Large Model Plant" for production sites. Another commenter³⁶⁵ indicated that some multi-well sites, central production facilities, and compressor

³⁶¹ *Standards of Performance for New, Reconstructed, and Modified Sources and Emissions Guidelines for Existing Sources: Oil and Natural Gas Sector Climate Review. Response to Public Comments on the November 2021 Proposed Rule and the December 2022 Supplemental Proposed Rule* (86 FR 63110, November 15, 2021; 87 FR 74702, December 6, 2022).

³⁶² 87 FR 74764 and 74765, December 6, 2022.

³⁶³ 87 FR 78768, December 6, 2022.

³⁶⁴ EPA-HQ-OAR-2021-0317-2399.

³⁶⁵ EPA-HQ-OAR-2021-0317-0808.

stations may contain 100–200 controllers.

One commenter³⁶⁶ indicated that the EPA's small, medium, and large model plants do not reflect the actual average size of transmission and storage facilities based on the average size reported in EPA's GHGI, and that the EPA should increase the size of its model plants to accurately reflect average plant sizes.

A commenter³⁶⁷ noted that intermittent controllers represent most of the pneumatic devices in operation within the petroleum and natural gas system segments today.

Response: In response to these comments, the EPA made the following updates to the controller model plants.

- Two new “midstream” model plants were added to represent gathering and boosting stations. The small midstream model plant contains 20 pneumatic controllers, and the large midstream model plant contains 100 pneumatic controllers.

- The three transmission and storage model plants used in the supplemental analysis were replaced by a small transmission and storage model plant (30 pneumatic controllers) and a large transmission and storage model plant (50 pneumatic controllers).

- The breakdown of controllers at the new small production model plants was updated to reflect a higher percentage of intermittent vent controllers. For new sources, the supplemental analysis assumed two low bleed and two intermittent vent controllers. This was updated to one low bleed and three intermittent vent controllers.

Comment: One commenter³⁶⁸ pointed out that for electric-powered compressed air systems, the EPA applied an annualization period of 15 years as opposed to the 6-year period in the 2021 Carbon Limits study.

Response: The EPA agrees with the commenter that, while the EPA correctly applied the cost estimates from the 2021 Carbon Limits study, the EPA incorrectly applied an annualization period of 15 years instead of the 6-year period in the Carbon Limits cost estimates. This realization caused the EPA to review all the capital recovery annualization periods for the zero-emissions options. This led to the following updates for the capital recovery annualization periods in the analysis.

- For electric controllers powered by the grid, from 15 years to 6 years.

- For solar-powered electric controllers, from 15 years to 10 years.
- For instrument air systems powered either by the grid or from generator from 15 to 6 years.

Comment: Commenters submitted information to support the EPA's understanding that zero-emitting options for process controllers are technologically and economically reasonable. As a result of comments submitted in response to the December 2022 Supplemental Proposal, the EPA engaged in a clarification discussion with EQT regarding its process controller replacement program.³⁶⁹ The EPA learned that EQT Corporation, one of the largest producers of natural gas in the U.S., successfully implemented a program to replace over 8,000 natural gas-driven controllers at their sites.³⁷⁰ EQT announced the replacement initiative in June 2021, and has completed the project. While EQT explored a variety of zero-emitting options, the option they found most effective was the use of generators to power electric controllers.

Response: Although the EPA evaluated the use of generators to power compressed air systems for process controllers at sites without grid electricity, the EPA did not consider the use of generators to power electric controllers at sites without grid electricity in the December 2022 Supplemental Proposal. Using available information, the EPA estimated costs for systems using electric controllers powered by a generator. The EPA estimates the capital costs for these types of systems to range from just under \$29,000 for the smallest production model plant to over \$350,000 for the largest midstream model plant and the annual costs to range from around \$8,500 for the smallest production model plant to over \$55,000 for the largest midstream model plant. For summary information on the cost effectiveness of the analyzed available control options, see tables 18 and 19. For more complete information on the cost analyses conducted for process controllers, see the TSD for the final rule.

2. Zero-Emissions Standard

Comment: Several commenters remarked that it would be difficult for some sites to comply with the zero-emissions standard for process controllers due to a lack of access to electrical power at rural locations.

Several commenters noted that sites are sometimes miles away from the existing electrical grid, and others mentioned that there can be challenges to connecting to a nearby grid, such as with right-of-way issues for placement of power lines.

Response: The commenters appear to suggest that the zero-emissions standard is only feasible if electrical grid power is available to sites. The EPA disagrees that grid power is necessary to comply with the zero-emissions standard for process controllers. The zero-emissions standard is technology-neutral and does not require that energy from the electrical grid be used to power controllers. There are many other technologically feasible and cost-effective options that are available to owners or operators to achieve zero emissions from process controllers, including self-contained controllers, solar-powered controllers, controllers powered by electric generators, and controllers that have their emissions routed to a process. As noted here, these options that are not powered by electricity from the commercial power grid are cost-reasonable. These options are discussed further in the December 2022 Supplemental Proposal (87 FR 74763).

Comment: The December 2022 Supplemental Proposal included discussion of the technical viability of solar-powered process controllers.³⁷¹ While many commenters on the November 2021 Proposal expressed the opinion that solar-powered process controllers were not a viable option due to perceived technical limitations, one commenter cited a study by Carbon Limits³⁷² that demonstrated solar-powered controls installed at well sites in remote and cold locations such as Northern Alberta and British Columbia have been proven to operate properly without major reliability issues. Several commenters on the December 2022 Supplemental proposal continued to state that solar-powered process controllers would not be feasible in some situations and specifically addressed the EPA's reliance on the Carbon Limits report. For example, one commenter indicated that the Carbon Limits report focuses on the reliability of solar power systems in colder climates, not areas with limited sun exposure. As a result, the commenter points out, the Carbon Limits study does not address the reliability of solar-powered systems in areas with limited sun exposure, such as West Virginia, or in canyons and mountain valleys.

³⁶⁶ EPA-HQ-OAR-2021-0317-2433.

³⁶⁷ EPA-HQ-OAR-2021-0317-2446.

³⁶⁸ EPA-HQ-OAR-2021-0317-2428.

³⁶⁹ See June 7, 2023, meeting memorandum in EPA-HQ-OAR-2021-0317.

³⁷⁰ <https://www.eqt.com/responsibility/pneumatic-device-replacement/>.

³⁷¹ 87 FR 74764, December 6, 2022.

³⁷² EPA-HQ-OAR-2021-0317-1451.

Commenters also noted that other factors limit the feasibility of including solar-powered systems at sites that have significant numbers of foggy or cloudy days, or high amounts of ice or snowfall, and in cold locations where battery storage could be negatively impacted. The commenters state that reliance on solar power leaves sites subject to the weather and possibly effectively shut down for days. One commenter noted that solar power may not be feasible for gathering and boosting operations, which have larger footprints and substantially greater power needs than other types of operations.

Response: Some commenters contend that solar power is not a feasible option to use for controllers at some sites because of perceived technical limitations. Considering that the electrical power needed by each controller is relatively low,³⁷³ the EPA reasonably expects that a solar power system can be sized with the appropriate number of panels and batteries to power process controllers at most, if not all, sites. The EPA does not agree with commenters' claim that powering process controllers with solar power is technically infeasible. The EPA has examined these claims from commenters and finds that solar technology has advanced such that it has overcome previous technical limitations and is now a technically viable control option. Further, the use of solar power is not required by this rule. Another control option determined to be cost-effective at all sites, based on the EPA's BSER analysis, is the use of a generator to power electric process controllers, and the use of a generator to power a compressed air system was cost-effective at larger sites. Other options available to meet the zero-emissions standard at sites without grid power and without using solar power include self-contained process controllers, or routing emissions from controllers to a process, although costs were not evaluated for these two options.

Regarding the suggestion that compliance with the zero-emissions standard is infeasible at sites requiring a large electricity demand because solar power would not adequately supply this amount of power, we note that most gathering and boosting stations and transmission and storage sites already have electrical grid power at the site. However, as evidenced by the tables below in this section that summarize the

cost analyses, sites that are not connected to the grid have one or more cost-effective alternatives other than using solar power (using a generator to power electric controllers or a compressed air system), and the owner/operator is able to choose their preferred compliance option for each site.

Comment: Several commenters requested that the EPA allow owners or operators to route emissions from process controllers to a control device that achieves 95 percent control. The commenters report that this would be a cost-effective emissions reduction method for the many sites that have control devices onsite already. Other commenters remark that they are already routing emissions from process controllers to control devices and that requiring a zero-emissions standard for units already controlled by 95 percent or more requires the same capital and annual investment, but with little additional emission reduction over the baseline.

Response: We evaluated the use of control devices achieving 95 percent pollution control in our analyses for the December 2022 Supplemental Proposal.³⁷⁴ This control option was determined not to be the BSER for new or existing sources and was not used to develop the process controller standards for the NSPS or the presumptive standards in the EG. Zero emissions from new and existing process controllers was shown in our analyses to be technically achievable through several available options, including the use of self-contained controllers, electrical controllers powered by electricity from the grid or solar power systems, or controllers powered by compressed air using electricity from the grid or from electric generators, and by routing emissions to a process. The EPA has also shown that at least some of these available options are cost-effective for different types of facilities (model plants). Since these options achieve a rate of zero GHG (methane) and VOC emissions, compared to an emission rate of up to 5 percent of the baseline emissions through the use of a control device, we have not changed our determination that a zero-emissions option is the BSER. The baseline that the EPA used for the BSER analysis did not assume that emissions from the collection of process controllers was already being controlled at a 95 percent reduction because EPA does not have information indicating that any sizable portion of the industry is already being controlled at that level. While the EPA acknowledges that some process

controllers may be subject to state-level regulations that result in such controls (95 percent reduction compared to uncontrolled emissions), the EPA does not have information indicating how prevalent such controls are for existing sources and therefore could not reasonably assume that such level of control reflected an accurate representation of a typical industry source, or even a typical source in a particular state or geographic region. While some state regulations may include a provision that could require certain process controllers to reduce emissions by 95 percent or more, those same regulations also include various exemptions, variances, and applicability thresholds that make it unclear which sources are actually achieving the 95 percent reductions. The EPA did not have sufficient information on this issue to alter the BSER analysis. The Agency was not presented with data or any empirical evidence to show how many, or which, sources are currently being controlled to this extent. The Agency was not compelled to alter the BSER analysis because of the anecdotal accounts provided by commenters. However, when developing state plans for the implementation of the EG for existing sources, states have the ability through RULOF to apply a less stringent standard with an appropriate demonstration in accordance with the requirements of 40 CFR part 60, subpart Ba.

Comment: Several commenters request that the EPA consider allowing the use of low-bleed or intermittent-bleed pneumatic controllers at low production/small sites. The commenters noted that some older facilities currently have very little throughput, and therefore low emissions from pneumatics due to infrequent activation. They also noted that low-producing wells could be close to the end of their production cycle life and may only contain a limited number of controllers. The commenters add that the complete retrofit of a low-producing facility is likely cost-prohibitive based on well economics and could result in many low production wells or stripper well sites shutting in production.

Response: As demonstrated in analyses conducted for the December 2022 Supplemental Proposal and the refreshed analysis conducted for the final rule (see section XI.D.3 below), we found zero-emissions options to be cost-effective even at small sites (*i.e.*, four process controllers at the site in our smallest model plant scenario). The emission factors used in the analyses are average emission factors, which are based on emissions from many sites

³⁷³ Estimate of 0.08 amps/controller in Carbon Limits. (2016) Zero emission technologies for pneumatic controllers in the USA—Applicability and cost effectiveness.

³⁷⁴ 87 FR 76765. December 6, 2022.

with varying actuation frequencies. There is considerable evidence that malfunctioning natural gas-driven intermittent vent controllers are a significant source of emissions and the emissions from an intermittent controller that is malfunctioning and venting continuously are not related to the actuation frequency. While sites with controllers that actuate infrequently may have lower than the average emissions, the cost effectiveness values for at least some zero-emissions control options (*i.e.*, electric controllers powered by the grid, by solar power, and by power created by an onsite generator) are comfortably within the range that the EPA considers to be acceptable (see 87 FR 74762), such that even if emissions were less than one-quarter of the average (which the EPA can reasonably expect to be rare), the EPA would still consider the costs acceptable given the emissions reductions that would be achieved.

Further, while the emissions from natural gas-driven pneumatic controllers at a small site may be low in comparison to those from a central production facility or gathering and boosting station, the sheer number of small sites means that the cumulative methane emissions from these sites are significant. The EPA estimates that 47 percent of the total nationwide emissions from pneumatic controllers occurs from sites with less than four controllers. In a study funded by DOE's National Energy Technology Laboratory (DOE-NETL), GSI Environmental Inc. (2022) estimates that marginal natural gas and oil wells account for 59 percent and 37 percent of cumulative methane emissions from oil and natural gas production, respectively, and roughly half of cumulative methane emissions from combined oil and natural gas production. Similarly, Omara, *et al.* (2022), estimate that low production well sites account for roughly half (37–75 percent) of all oil and natural gas well site methane emissions. When considering the costs of the various control options in conjunction with the associated emission reduction of those same control options, the EPA found even for sites with relatively few

process controllers, it was cost-effective to achieve a zero-emissions standard. For additional discussion of marginal wells, see chapter 6 of the Final Rule TSD. Lastly, when developing state plans for the implementation of the EG for existing sources, states have the ability through RULOF to apply a less stringent standard with an appropriate demonstration in accordance with the requirements of 40 CFR part 60, subpart Ba.

Comment: Several commenters are concerned about the secondary emissions that will be created if natural gas-fired generators are used to power process controllers. The commenters are concerned that the operation of generators could result in increased cumulative nitrogen oxide (NO_x) and VOC emissions as well as criteria pollutants and hazardous air pollutants (HAP). The commenters indicated that these emissions could potentially offset the emissions reductions from the methane and VOC, and these emissions from sites in ozone non-attainment areas could prevent those areas from gaining ozone attainment status.

Response: The EPA recognizes that if owners and operators elect to comply by installing and operating a generator, there will be secondary emissions generated from the fuel combustion; however, we have estimated the emissions that would be created by generators and found that they are far outweighed by the VOC and GHG (methane) emissions reduction that would be achieved by using process controllers that are not driven by natural gas. For the December 2022 Supplemental Proposal, while we did recognize that a commenter had provided estimates of these emissions, we did not separately analyze the secondary emissions that would be created if a generator was used to power this equipment.

We have now conducted that analysis and estimate that for a natural gas-fired generator to power this equipment, the secondary criteria pollutant emissions would be 43 pounds per year (lb/yr) CO, 306 lb/yr NO₂, 6 lb/yr PM, and 3 lb/yr PM_{2.5} for a 5 HP compressor and 172 lb/yr CO, 1,222 lb/yr NO₂, 26 lb/yr PM,

and 13 lb/yr PM_{2.5}, for a 20 HP compressor. The secondary GHG emissions generated as a result of this electricity generation are estimated to be 11,654 lb/yr CO₂, 0.2 lb/yr methane, and 0.02 lb/yr N₂O for a 5 HP compressor and 46,618 lb/yr CO₂, 0.9 lb/yr methane, and 0.09 lb/yr N₂O for a 20 HP compressor. Considering the global warming potential of these GHGs, the total CO₂ Eq. emissions would be 11,667 lb/yr CO₂ Eq. from a 5 HP compressor and 46,666 lb/yr CO₂ Eq. from a 20 HP compressor. With the total CO₂ Eq. emissions from process controllers at a small site estimated to be 303,000 lb/yr and 7.5 million lb/yr for a large site, the total CO₂ Eq. reduction from the use of zero-emissions process controllers powered by a generator running a compressed air system would be more than 95 percent when compared to the uncontrolled methane emissions from natural gas-driven controllers. No other secondary impacts are expected. Considering this information regarding secondary emissions, we continue to find that the BSER for reducing methane and VOC emissions from natural gas-driven controllers in the production and the transmission and storage segments of the industry to be the use of controllers that have methane and VOC emission rates of zero.

3. Final BSER Conclusions

Based on the updates discussed above in section XI.D.2, the EPA refreshed the BSER cost analysis for new sources. This analysis estimates the cost and emission reductions for the following zero-emissions options. For sites with access to electricity, the zero-emissions options include electric controllers and pneumatic controllers powered by compressed air systems. For sites without access to electricity, the zero-emissions options include solar-powered electric controllers, electric controllers powered by a generator, and pneumatic controllers driven by a compressed air system powered by an onsite generator. The results of these updated analyses are shown in table 18. For more detailed information on these cost estimates, see the TSD for the final rule.

TABLE 18—SUMMARY OF PROCESS CONTROLLER SYSTEMS NOT DRIVEN BY NATURAL GAS COST EFFECTIVENESS ANALYSIS FOR NEW SOURCES

Location type model plant controller system	Cost effectiveness (\$/ton) ^a			
	Single pollutant		Multipollutant	
	Methane	VOC	Methane	VOC
Sites With Electricity				
<i>Small Production:</i>				
Electric controllers	\$378	\$1,360	\$189	\$680
Compressed air	2,316	8,330	1,158	4,165
<i>Medium Production:</i>				
Electric controllers	289	1,039	144	520
Compressed air	1,270	4,569	635	2,285
<i>Large Production:</i>				
Electric controllers	235	847	118	423
Compressed air	865	3,112	433	1,556
<i>Small Midstream:</i>				
Electric controllers	235	847	118	423
Compressed air	865	3,112	433	1,556
<i>Large Midstream:</i>				
Electric controllers	210	754	105	377
Compressed air	485	1,745	243	872
<i>Small T&S:</i>				
Electric controllers	566	2,036	283	1,018
Compressed air	2,007	7,219	1,003	3,609
<i>Large T&S:</i>				
Electric controllers	533	1,917	266	959
Compressed air	1,951	7,018	975	3,509
Sites Without Electricity				
<i>Small Production:</i>				
Electric controllers—Solar	276	991	138	496
Electric controllers—Generator	1,393	5,012	697	2,506
Compressed air—Generator	4,199	15,106	2,100	7,553
<i>Medium Production:</i>				
Electric controllers—Solar	215	774	108	387
Electric controllers—Generator	795	2,860	398	1,430
Compressed air—Generator	2,085	7,500	1,042	3,750
<i>Large Production:</i>				
Electric controllers—Solar	179	643	89	322
Electric controllers—Generator	665	2,394	333	1,197
Compressed air—Generator	1,396	5,020	698	2,510
<i>Small Midstream:</i>				
Electric controllers—Solar	179	643	89	322
Electric controllers—Generator	665	2,394	333	1,197
Compressed air—Generator	1,396	5,020	698	2,510
<i>Large Midstream:</i>				
Electric controllers—Solar	162	581	81	291
Electric controllers—Generator	370	1,333	185	666
Compressed air—Generator	511	1,837	255	919
<i>Small T&S:</i>				
Electric controllers—Solar	435	1,566	218	783
Electric controllers—Generator	1,327	4,775	664	2,388
Compressed air—Generator	2,725	9,804	1,363	4,902
<i>Large T&S:</i>				
Electric controllers—Solar	411	1,478	205	739
Electric controllers—Generator	1,330	4,786	665	2,393
Compressed air—Generator	2,585	9,298	1,292	4,649

^a For the production segment, the owners and operators realize the savings for the natural gas that is not emitted and not lost. The cost effectiveness values shown in this summary table do not consider these savings. If the EPA were to consider these savings, then the cost effectiveness figures in the table (\$/ton methane reduced) would reduce, which would mean the options assessed would be even more cost reasonable than already shown in this table.

For new sources, the EPA finds that all the options identified in table 18 are adequately demonstrated options for use of process controllers that are not driven by natural gas, thus resulting in zero

GHG and VOC emissions. For overall cost effectiveness to be considered reasonable for new sources, either the cost effectiveness of GHG (methane) or VOC on a single-pollutant basis must be

within the ranges considered reasonable by the EPA or the cost effectiveness of both methane and VOC on a multipollutant basis must be within the ranges considered reasonable by the

EPA. As shown in table 18, for every model plant in all sectors, there are two or more options for new sources for which the cost effectiveness is considered reasonable by the EPA. This is true for sites with electricity from the grid, as well as sites without this electrical service. For example, for a medium sized model plant in the transmission and storage segment at sites without access to grid electricity, the single-pollutant cost effectiveness values for solar-powered electric controllers are \$435 per ton of methane and \$1,566 per ton of VOC, and the single-pollutant cost effectiveness values for electric controllers powered by a generator are \$1,327 per ton of methane and \$4,775 per ton of VOC. All of these values are within the range that the EPA considers to be reasonable. For a compressed air system powered by a generator for this model plant, the single pollutant values are \$2,725 per ton of methane and \$9,804 per ton of VOC. While these values exceed the levels typically considered reasonable by the EPA, the multipollutant cost effectiveness values of \$1,363 per ton of methane and \$4,902 per ton of VOC are within the ranges considered reasonable by the EPA. Therefore, the EPA considers the costs of all three zero-emissions options for this model plant to be reasonable given the associated 100 percent emission reduction achieved.

As discussed above in section XI.D.2, some commenters contend that solar-powered controller systems are not a technically feasible emission control option. The EPA disagrees with this comment, as the successful use of solar-powered controllers has been demonstrated. The EPA accepts that there may be certain situations where site-specific conditions may not be favorable to the use of solar-powered controller systems. However, this analysis shows that there are other demonstrated options available for all model plant sizes at sites without electricity with costs that are considered reasonable given the resulting methane and VOC emission reductions. In addition, while information was not available to fully analyze the costs, the option of collecting the emissions from natural gas-driven pneumatic controllers and routing them to a process and the option of self-contained natural gas-driven pneumatic controllers also achieve 100 percent emission reductions. Therefore, they are considered equivalent to the use of controllers not driven by natural gas.

The options evaluated for sites without grid electricity include the use of a generator to power either electric

controllers or an instrument air (compressed air) system. As pointed out by some commenters, the use of these generators will create secondary air pollution. As discussed in more detail above in section XI.D.2, on an individual site basis the EPA concludes that the emissions that would be created by generators are far outweighed by the methane and VOC emissions reduction that would be achieved by using process controllers that are not driven by natural gas.

In conclusion, based on comments received, the EPA refreshed the BSER analysis with respect to costs and the associated emissions reductions. The EPA also considered other comments on the BSER analysis and the proposed zero-emissions standard for process controllers. After this consideration, the EPA continued to conclude that BSER for new process controllers is the use of zero-emissions process controllers that do not emit GHG (methane) or VOC to the atmosphere. Therefore, the final rule maintains the proposed zero-emissions standard.

The EPA also refreshed the BSER analysis for existing sources. For each zero-emissions option, the foundation for the cost estimates for existing sources was the same as for new sources. However, adjustments were made to account for differences in the costs that would be incurred for existing sources. For example, the installation costs were assumed to be twice as high for existing sources as compared to new sources. Another difference between the new and existing source analysis is related to the types of controllers assumed to be onsite for purposes of the model plants utilized in the analysis. The new source model plants did not include any high-bleed controllers. For existing sources, it was assumed that there was one high-bleed controller at every model plant. Thus, the baseline emissions, and the resulting emission reductions, were greater for existing sources as compared to new sources. The same zero-emissions options were evaluated for existing sources as for new sources, and, as for new sources, the EPA finds that all the options identified are adequately demonstrated options for use of process controllers that are not driven by natural gas, thus resulting in zero GHG (methane) emissions. The results of the refreshed cost analysis for existing sources is provided in table 19.

TABLE 19—SUMMARY OF PROCESS CONTROLLER SYSTEMS NOT DRIVEN BY NATURAL GAS METHANE COST EFFECTIVENESS ANALYSIS FOR EXISTING SOURCES

Location type	Cost effectiveness ^a
Model plant controller system	(\$/ton methane reduced)
Sites With Electricity	
<i>Small Production:</i>	
Electric controllers	\$449
Compressed air	2,157
<i>Medium Production:</i>	
Electric controllers	375
Compressed air	1,232
<i>Large Production:</i>	
Electric controllers	347
Compressed air	899
<i>Small Midstream:</i>	
Electric controllers	347
Compressed air	899
<i>Large Midstream:</i>	
Electric controllers	334
Compressed air	538
<i>Small T&S:</i>	
Electric controllers	732
Compressed air	1,924
<i>Large T&S:</i>	
Electric controllers	754
Compressed air	1,906
Sites Without Electricity	
<i>Small Production:</i>	
Electric controllers—Solar	329
Electric controllers—Generator	1,384
Compressed air—Generator	4,207
<i>Medium Production:</i>	
Electric controllers—Solar	281
Electric controllers—Generator	871
Compressed air—Generator	2,233
<i>Large Production:</i>	
Electric controllers—Solar	264
Electric controllers—Generator	845
Compressed air—Generator	1,685
<i>Small Midstream:</i>	
Electric controllers—Solar	264
Electric controllers—Generator	845
Compressed air—Generator	1,685
<i>Large Midstream:</i>	
Electric controllers—Solar	258
Electric controllers—Generator	538
Compressed air—Generator	679
<i>Small T&S:</i>	
Electric controllers—Solar	564
Electric controllers—Generator	1,493
Compressed air—Generator	2,797
<i>Large T&S:</i>	
Electric controllers—Solar	582
Electric controllers—Generator	1,653
Compressed air—Generator	2,978

^a For the production segment, the owners and operators realize the savings for the natural gas that is not emitted and not lost. The cost effectiveness values shown in this summary table do not consider these savings. If the EPA were to consider these savings, then the cost effectiveness figures in the table (\$/ton methane reduced) would reduce, which would mean the options assessed would be even more cost reasonable than already shown in this table.

As shown in table 19, for every model plant in all sectors, there are two or more options for which the cost effectiveness for methane for existing sources is considered reasonable by the EPA. This is true for sites with electricity from the grid, as well as sites

without this electrical service. For example, for the small model plant in the transmission and storage segment at sites without access to electricity, the cost effectiveness values (\$ per ton of methane) are \$564, \$1,493, and \$2,797 for solar-powered electric controllers, electric controllers powered by a generator, and compressed air powered by a generator, respectively. While the cost effectiveness for compressed air powered by a generator is above the level typically considered reasonable by the EPA, the other two options are well below the levels considered reasonable. The discussion above related to technical feasibility of solar-powered controllers and secondary emissions from generators for new sources is equally applicable for existing sources. As for new sources, routing pneumatic controller emissions to a process and using self-contained natural gas-driven pneumatic controllers are other control options available to achieve a zero-emissions standard.

In conclusion, based on comments received, the EPA refreshed the BSER cost analysis for existing sources. The EPA also considered other comments on the BSER analysis and the proposed zero-emissions presumptive standard for process controllers. After this consideration, the EPA continues to conclude that BSER for existing process controllers is the use of zero-emissions process controllers that do not emit methane to the atmosphere. Therefore, the final emission guideline maintains the proposed zero-emissions presumptive standard.

4. Compliance Dates

Comment: Several commenters state that a 60-day compliance deadline for new/modified sources is unrealistic due to supply chain concerns, personnel shortages, and inflation. Due to supply chain shortages and disruption, one commenter remarked that generators and other equipment and parts necessary for zero-emissions systems can take up to 3 months or longer for delivery, while another reports that they currently experience lead times for non-natural-gas-driven pneumatic controllers, generators, and air compressors ranging from 12 to 24 months. The commenters note that there is no indication that this lead time will improve in the near future and believe it can be expected to worsen as owners and operators across the country increase demand in response to the final rule. Commenters contend that this leaves even the most responsible owner or operator without the ability to comply within 60 days. Some commenters recommend a compliance

deadline of 24 months from the publication date of the final rule and others propose at least a 1-year timeframe for NSPS OOOOb compliance to allow for procurement and installation of the systems and equipment necessary (including labor necessary for installation).

One commenter contends that supply chain considerations do not alter the reasonableness of the EPA's proposal. The commenter relays that EQT, the largest natural gas producer in the U.S., retrofitted all its sites to eliminate natural gas-driven controllers in less than 1.5 years³⁷⁵ and another oil and gas producer anticipates it will have replaced "nearly all" of its controllers with zero-emitting devices within 4 years.³⁷⁶ The commenter adds that a recent report by Datu Research further underscores that the supply chain for the production of zero-emitting technologies is not a barrier for industrywide adoption of zero-emissions controllers and that, on the contrary, the supply chain is strong enough to support implementation of the EPA's proposed standards.³⁷⁷ According to the commenter, Datu's report identifies 40 providers of zero-emitting controllers, and a survey of nine of these providers demonstrates that suppliers are well-equipped to meet anticipated demand within the EPA's proposed regulatory timeline.³⁷⁸ The commenter remarks that some key findings of the Datu report include the following:

- Technology providers have strategies for meeting current supply chain challenges. Though procurement delays have been a reality for some suppliers, they have employed strategies like paying higher prices, storing extra quantities of supplies, bringing in more procurement personnel, going to different distributors, spot-buying on the open market, and finding contract manufacturing sites. Larger companies reported facing fewer hurdles.³⁷⁹
- Regulatory certainty steadies demand. Even considering supply chain concerns, providers have confidence in their ability to expand production capacity so long as regulatory certainty

³⁷⁵ "EQT Eliminates Nearly 9,000 Natural Gas-Powered Pneumatic Devices," PRNewswire (January 4, 2023) <https://www.prnewswire.com/news-releases/eqt-eliminates-nearly-9-000-natural-gas-powered-pneumatic-devices-301713418.html>.

³⁷⁶ Diamondback Energy, "2021 Corporate Sustainability Report 8" (2021), <https://www.diamondbackenergy.com/static-files/faf5ab25-5ab5-4404-8c04-c7bd387ae418>.

³⁷⁷ Data Research, "Zero-emission Alternatives to Pneumatic Control: How Ready are Technology Providers to Meet Increased Demand?" (Jan. 2023).

³⁷⁸ Id. at 5, 9.

³⁷⁹ Id. at 3.

helps keep demand steady over multiple years.³⁸⁰

Response: Based on these comments, it appears that some equipment necessary for the installation of zero-emitting process controllers may not be available quickly enough, and in large enough quantities, to enable new sources to comply with the final standard upon startup, or within 60 days after the publication of the final NSPS. Supplemental information submitted by one commenter provided information regarding current equipment lead time and market conditions.³⁸¹ According to that information, some of the operators surveyed report that they are experiencing delays in the availability of process controllers, electrical transformers, generator skids, and compressor skids of up to 12 months. In addition, the zero-emissions technology supplier survey information also indicates that some equipment providers will need to ramp up production, and some components may not be widely available within 60 days after the publication of the final rule.

The equipment types discussed in the information provided by these commenters are relevant to the installation of zero-emitting controllers. Further, the equipment types that the EPA believes are necessary to comply with the final standards for process controllers in NSPS OOOOb are quite different from the type of equipment used to comply with the standards for these sources found in NSPS OOOOa. For example, compliance with NSPS OOOOa for most sources likely does not require electrical transformers, generator skids, or compressor skids. Due to these considerations, the EPA is not certain that new sources could obtain the equipment necessary to demonstrate compliance immediately upon the effective date of the final rule and is therefore finalizing a compliance deadline for process controllers that allows for up to 1 year from the effective date of the final rule. This means that new sources will have up to 1 year to come into full compliance with the final standard of zero emissions. Until that final date of compliance, owners and operators must demonstrate compliance with an interim standard which mirrors the requirements for sites in Alaska that do not have access to electrical power found at 40 CFR 60.5390b(b). In summary, the requirements for such sites allow for two compliance options.

³⁸⁰ Id. at 11–12.

³⁸¹ API, *Operator Survey of Supply Chain Delays for Equipment Needed for EPA Proposed NSPS OOOOb Methane Rule*.

One option is to use low-bleed controllers and/or intermittent vent controllers, and to perform monitoring of intermittent vent controllers to ensure they do not vent during idle periods. The other option is to route process controller emissions to a control device achieving a 95 percent reduction in emissions. As the current NSPS OOOOa requires that low-bleed controllers be used, owners/operators of new and recently modified or reconstructed sites will be able to readily obtain the equipment necessary for these types of process controllers. Complying with the interim standard described above does not require using the equipment that commenters claimed they could not easily obtain (*i.e.*, the equipment needed to meet the zero-emissions standard). Therefore, the EPA expects no sites to have any problems complying with these interim requirements within 60 days after publication of the final rule. If an owner or operator opts to comply with the interim standard during the one year following publication of the final rule, then they must still comply with the final zero-emissions standard after the year has passed. Owners and operators can, and are encouraged to, comply with the final zero-emissions standard before the year has passed.

6. Modification and Reconstruction Criteria and Requirements

Under 40 CFR 60.14, any physical or operational change to an existing facility resulting in an emissions increase is a modification. In the December 2022 Supplemental Proposal, we stipulated that in addition to this definition of a modification, a modification would occur for purposes of this particular affected facility when a process controller is added to a site, as this addition would increase emissions from the affected facility, which is the collection of controllers at a site.

Comment: Commenters requested that the EPA clarify that, for purposes of the collection of process controllers at a site, a modification would occur only when a natural gas-driven process controller is added, rather than the addition of any type of process controller. The commenters pointed out that the addition of a controller not driven by natural gas would not increase emissions from the affected source.

Response: While it was our intention in the December 2022 Supplemental Proposal to only include the addition of natural gas-driven controllers in the conditions that would constitute a modification, as only those controllers could potentially increase emissions, we agree that the proposed regulatory text

did not specify this. We therefore have changed what we proposed for regulatory language to clarify that the addition of one or more natural gas-driven controllers to a site constitutes a modification.

Comment: Commenters also requested that the EPA clarify which controllers would be considered in the determination of whether a reconstruction has taken place. In the December 2022 Supplemental Proposal, we included provisions that would allow owners and operators to choose to determine whether a reconstruction has occurred as it is defined in 40 CFR 60.15(b), based on the fixed capital cost of new process controllers, or they could determine whether a reconstruction had occurred based on the percentage of the total number of process controllers replaced.

Response: Like the provisions for modifications, we are clarifying in the final rule that reconstruction would be considered to occur whenever greater than 50 percent of the number of existing onsite natural gas-driven process controllers are replaced, rather than the replacement of any type of process controller, as only natural gas-driven process controllers are considered to be affected facilities for the NSPS.

Comment: In addition to these clarifications regarding the criteria for determining whether a modification or reconstruction has taken place, one commenter stated that it is unclear how the notification requirements of 40 CFR 60.15 apply for reconstruction. The commenter noted that the proposed language in 40 CFR 60.5365b(d)(2)(ii) suggests that reconstructed natural gas-driven process controllers would be subject to some of the requirements included in 40 CFR 60.15, which include 60-day notification and Administrator approval. According to the commenter, this conflicts with information presented in table 5 of the proposed regulatory text, which stated that 40 CFR 60.15(d) does not apply to process controllers. The commenter believes it was the EPA's intent to not apply the additional notification and approval, given the number of facilities that will trigger reconstruction over time.

Response: We agree that we did not intend for facilities to be required to notify the Administrator of upcoming process controller replacements that would constitute a reconstruction or for the Administrator to be required to review the notification and determine whether the replacements constitute a reconstruction. We have changed what we proposed for regulatory text to not

refer to the requirements of 40 CFR 60.15(d) and have kept the information presented in table 5 of the proposed regulatory text, which states that 40 CFR 60.15(d) does not apply to process controllers.

7. Change in Pneumatic Controller Terminology

To assist with avoiding possible confusion about which types of "controllers" are included in the definition of this affected facility, and which types of controllers must be considered for purposes of the reconstruction and modification provisions, we have changed the terminology from "pneumatic controllers" (used in both the November 2021 Proposal and the December 2022 Supplemental Proposal) to "process controllers" in the final rule. When reviewing comments, the EPA noticed that not all commenters used the same terminology, so the Agency thought it best to clarify now. The EPA has made this change both in the final rule preamble and the final regulatory text. The term "process controller" is broader in scope because it includes pneumatic controllers as well as other types of controllers that are not pneumatic. Only a subset of process controllers used by oil and gas facilities are pneumatic controllers that use pressurized air (compressed air or instrument air) or gas to perform their functions. Other process controllers might use electricity to perform their functions. From a technical perspective, electronic process controllers are not true "pneumatic" devices, but these electronic process controllers can be used to perform the same function as a pneumatic controller, and they achieve the zero-emissions standard. The EPA changed the terminology because we did not want to inadvertently convey that misimpression that process controllers had to be pneumatic. To be clear, the final rule applies to the collection of natural gas-driven process controllers at a well site. Process controllers that are not driven by natural gas are not included in the affected facility. Further, only process controllers driven by natural gas will be counted when determining whether a modification or reconstruction has occurred.

E. Pumps

In the December 2022 Supplemental Proposal, the EPA proposed for both the NSPS OOOOb and EG OOOOc to define the pumps affected facility, and designated facility, as the collection of all natural gas-driven pumps at a site. For a limited subset of the affected pump facilities, the EPA proposed a

tiered structure of standards based on conditions at the affected facility. Among other comments, the EPA received comments regarding: (1) the BSER analysis and conclusions, (2) the compliance dates, (3) the requirements associated with the tiered approach for some pumps, (4) the recordkeeping and reporting requirements for pumps not included in the definition of the affected facility, and (5) the criteria that would determine whether an affected pump facility was modified or reconstructed. These comments and the EPA's responses to these comments apply to the standards and presumptive standards in NSPS OOOOb and EG OOOOc, respectively. A summary of the comments received and the EPA's response to these comments, including any updates made to the final rule, as applicable, are provided below. The EPA's full response to comments on the November 2021 Proposal and December 2022 Supplemental Proposal, including any comments not discussed in this preamble, can be found in the EPA's RTC document for the final rule.³⁸²

In addition to the updates made to the final rule to address these comments, one other change in terminology was made to address the types of equipment that may be used to perform the functions of pumps. That change is discussed further here.

1. BSER Analysis and Conclusions

The EPA received several comments regarding the proposed standards for pumps, including requests that the BSER analyses for pumps be revised to more closely match the analyses conducted for process controllers, requests for technology-neutral

standards, and comments regarding the infeasibility certifications required.

Comment: One commenter states that the EPA relied on costs from the 2016 and 2021 Carbon Limits reports for process controllers, but that the EPA used different costs and assumptions as they pertained to converting to electric (assumed to be grid power) and solar pumps, which are not well documented and appear to be based on old information dating back to 2012.

Another commenter remarked that the EPA proposed a set of requirements for natural gas-driven process controllers completely distinct from that for natural gas-driven pumps, with sometimes conflicting statements made to justify the EPA's decisions. The commenter requested that the requirements for both process controllers and pumps be streamlined for consistency, with technology-neutral standards that do not require additional certifications and that allow for emissions to be routed to a control device. Another commenter urged the EPA to mirror the proposed process controller standard for pumps by including pumps routed to a process as a compliance option and eliminating the tiered feasibility exemption at sites without electricity.

Response: The EPA acknowledges that the analysis for pumps in the December 2022 Supplemental Proposal relied on costs from previous analyses that were updated to reflect changes in prices due to inflation. However, those cost figures used in the December 2022 Supplemental Proposal did not reflect more recent changes that have occurred in control technology or the impact of those changes on costs, such as a reduction in costs for solar panels and batteries. Therefore, the EPA updated its

analysis for pumps to use the more recent information for non-natural gas-driven pump options. This included information from the Carbon Limits reports, which addressed pump options as well as process controllers.

A summary of the results of the updated analysis showing the cost effectiveness of the pumps affected facility emissions control options is shown in table 20. Further information regarding the analysis conducted for pumps may be found in the NSPS OOOOb and EG OOOOc TSD for this final rulemaking, which is available in the docket for this action. The cost effectiveness values shown in table 20 are based on the estimated total annual costs and the emissions reductions associated with each control option. The emissions reductions for a combustion control device are assumed to be 95 percent and are assumed to be 100 percent for all other control options evaluated. For new sources that will be covered by NSPS OOOOb, cost effectiveness was calculated on a single-pollutant basis, where the total annual cost was applied entirely to the reduction of each pollutant, and was also calculated on a multipollutant basis, where half the cost of control is assigned to the methane reduction and half to the VOC reduction. Table 20 shows the cost effectiveness values for GHG (methane) and VOC, which is applicable for the determination of BSER for new sources. Table 21 provides the cost effectiveness for GHG (methane) for existing sources. Further information regarding the cost effectiveness values for pumps may be found in the NSPS OOOOb and EG OOOOc TSD for this rulemaking, which is available in the docket for this action.

TABLE 20—SUMMARY OF COST EFFECTIVENESS ANALYSIS OF PUMP EMISSIONS REDUCTION OPTIONS FOR NEW SOURCES

Location type and number of pumps at site	Cost effectiveness (\$/ton) ^a			
	Single pollutant		Multipollutant	
	Methane	VOC	Methane	VOC
Sites With Electricity				
<i>Electric pumps—production segment:</i>				
One diaphragm	\$349	\$1,256	\$175	\$628
Two diaphragm	349	1,256	175	628
Three diaphragm	349	1,256	175	628
Four diaphragm	349	1,256	175	628
<i>Electric pumps—transmission and storage segment:</i>				
One diaphragm	267	9,650	134	4,825
Two diaphragm	267	9,650	134	4,825
Three diaphragm	267	9,650	134	4,825
Four diaphragm	267	9,650	134	4,825
<i>Compressed air-driven pumps—production segment:</i>				

³⁸² Standards of Performance for New, Reconstructed, and Modified Sources and Emissions Guidelines for Existing Sources: Oil and

Natural Gas Sector Climate Review. Response to Public Comments on the November 2021 Proposed Rule and the December 2022 Supplemental

Proposed Rule (86 FR 63110, November 15, 2021; 87 FR 74702, December 6, 2022).

TABLE 20—SUMMARY OF COST EFFECTIVENESS ANALYSIS OF PUMP EMISSIONS REDUCTION OPTIONS FOR NEW SOURCES—Continued

Location type and number of pumps at site	Cost effectiveness (\$/ton) ^a			
	Single pollutant		Multipollutant	
	Methane	VOC	Methane	VOC
One diaphragm	3,202	11,517	1,601	5,758
Two diaphragm	1,711	6,156	856	3,078
Three diaphragm	1,215	4,369	607	2,185
Four diaphragm	966	3,476	483	1,738
<i>Compressed air-driven pumps—transmission and storage segment:</i>				
One diaphragm	2,451	88,469	1,225	44,235
Two diaphragm	1,310	47,291	655	23,646
Three diaphragm	930	33,565	465	16,783
Four diaphragm	740	26,702	370	13,351
Sites Without Electricity				
<i>Electric solar pumps—production segment:</i>				
One diaphragm	395	1,421	198	711
Two diaphragm	395	1,421	198	711
Three diaphragm	395	1,421	198	711
Four diaphragm	395	1,421	198	711
<i>Electric solar pumps—transmission and storage segment:</i>				
One diaphragm	302	10,918	151	5,459
Two diaphragm	302	10,918	151	5,459
Three diaphragm	302	10,918	151	5,459
Four diaphragm	302	10,918	151	5,459
<i>Compressed air-driven pumps with a generator—production segment:</i>				
One diaphragm	5,130	18,453	2,565	9,226
Two diaphragm	2,676	9,624	1,338	4,812
Three diaphragm	1,857	6,682	929	3,341
Four diaphragm	1,448	5,210	724	2,605
<i>Compressed air-driven pumps with a generator—transmission and storage segment:</i>				
One diaphragm	3,927	141,752	1,963	70,876
Two diaphragm	2,048	73,933	1,024	36,966
Three diaphragm	1,422	51,326	711	25,663
Four diaphragm	1,109	40,023	554	20,011
<i>Route pump emissions to process through existing VRU—production segment:</i>				
One diaphragm	472	1,699	236	849
Two diaphragm	472	1,699	236	849
Three diaphragm	472	1,699	236	849
Four diaphragm	472	1,699	236	849
<i>Route pump emissions to process through existing VRU—transmission and storage segment:</i>				
One diaphragm	361	13,050	181	6,525
Two diaphragm	361	13,050	181	6,525
Three diaphragm	361	13,050	181	6,525
Four diaphragm	361	13,050	181	6,525
<i>Route pump emissions to existing control device—production segment:</i>				
One diaphragm	497	1,788	249	894
Two diaphragm	497	1,788	249	894
Three diaphragm	497	1,788	249	894
Four diaphragm	497	1,788	249	894
<i>Route pump emissions to existing control device—transmission and storage segment:</i>				
One diaphragm	381	13,737	190	6,869
Two diaphragm	381	13,737	190	6,869
Three diaphragm	381	13,737	190	6,869
Four diaphragm	381	13,737	190	6,869
<i>Route pump emissions to process through new VRU—production segment:</i>				
One diaphragm	6,985	25,127	3,493	12,563
Two diaphragm	3,729	13,413	1,864	6,706
Three diaphragm	2,643	9,508	1,322	4,754
Four diaphragm	2,101	7,556	1,050	3,778
<i>Route pump emissions to process through new VRU—transmission and storage segment:</i>				
One diaphragm	5,347	193,021	2,673	96,510
Two diaphragm	2,854	103,035	1,427	51,518
Three diaphragm	2,023	73,040	1,012	36,520
Four diaphragm	1,608	58,043	804	29,021

TABLE 20—SUMMARY OF COST EFFECTIVENESS ANALYSIS OF PUMP EMISSIONS REDUCTION OPTIONS FOR NEW SOURCES—Continued

Location type and number of pumps at site	Cost effectiveness (\$/ton) ^a			
	Single pollutant		Multipollutant	
	Methane	VOC	Methane	VOC
<i>Route pump emissions to new control device—production segment:</i>				
One diaphragm	7,971	28,673	3,985	14,336
Two diaphragm	4,234	15,230	2,117	7,615
Three diaphragm	2,988	10,750	1,494	5,375
Four diaphragm	2,366	8,509	1,183	4,255
<i>Route pump emissions to new control device—transmission and storage segment:</i>				
One diaphragm	6,101	220,258	3,051	110,129
Two diaphragm	3,241	116,997	1,620	58,499
Three diaphragm	2,287	82,577	1,144	41,289
Four diaphragm	1,811	65,367	905	32,684

^a For the production segment, the owners and operators realize the savings for the natural gas that is not emitted and not lost. The cost effectiveness values shown in this summary table do not consider these savings. If the EPA were to consider these savings, then the cost effectiveness figures in the table (\$/ton methane reduced) would reduce, which would mean the options assessed would be even more cost reasonable than already shown in this table.

TABLE 21—SUMMARY OF COST EFFECTIVENESS ANALYSIS OF PUMP EMISSIONS REDUCTION OPTIONS FOR EXISTING SOURCES

Location type and number of pumps at site	Cost effectiveness (\$/ton) ^a
	Methane
Sites With Electricity	
<i>Electric pumps—production segment:</i>	
One diaphragm	\$349
Two diaphragm	349
Three diaphragm	349
Four diaphragm	349
<i>Electric pumps—transmission and storage segment:</i>	
One diaphragm	267
Two diaphragm	267
Three diaphragm	267
Four diaphragm	267
<i>Compressed air-driven pumps—production segment:</i>	
One diaphragm	3,461
Two diaphragm	1,731
Three diaphragm	1,154
Four diaphragm	865
<i>Compressed air-driven pumps—transmission and storage segment:</i>	
One diaphragm	2,649
Two diaphragm	1,325
Three diaphragm	883
Four diaphragm	662
Sites Without Electricity	
<i>Electric solar pumps—production segment:</i>	
One diaphragm	395
Two diaphragm	395
Three diaphragm	395
Four diaphragm	395
<i>Electric solar pumps—transmission and storage segment:</i>	
One diaphragm	302
Two diaphragm	302
Three diaphragm	302
Four diaphragm	302
<i>Compressed air-driven pumps with a generator—production segment:</i>	
One diaphragm	6,143
Two diaphragm	3,072
Three diaphragm	2,048
Four diaphragm	1,536
<i>Compressed air-driven pumps with a generator—transmission and storage segment:</i>	
One diaphragm	4,702
Two diaphragm	2,351

TABLE 21—SUMMARY OF COST EFFECTIVENESS ANALYSIS OF PUMP EMISSIONS REDUCTION OPTIONS FOR EXISTING SOURCES—Continued

Location type and number of pumps at site	Cost effectiveness (\$/ton) ^a
	Methane
Three diaphragm	1,567
Four diaphragm	1,176
<i>Route pump emissions to process through existing VRU—production segment:</i>	
One diaphragm	251
Two diaphragm	251
Three diaphragm	251
Four diaphragm	251
<i>Route pump emissions to process through existing VRU—transmission and storage segment:</i>	
One diaphragm	192
Two diaphragm	192
Three diaphragm	192
Four diaphragm	192
<i>Route pump emissions to existing control device—production segment:</i>	
One diaphragm	264
Two diaphragm	264
Three diaphragm	264
Four diaphragm	264
<i>Route pump emissions to existing control device—transmission and storage segment:</i>	
One diaphragm	202
Two diaphragm	202
Three diaphragm	202
Four diaphragm	202
<i>Route pump emissions to process through new VRU—production segment:</i>	
One diaphragm	7,719
Two diaphragm	3,985
Three diaphragm	2,740
Four diaphragm	2,118
<i>Route pump emissions to process through new VRU—transmission and storage segment:</i>	
One diaphragm	5,908
Two diaphragm	3,050
Three diaphragm	2,098
Four diaphragm	1,621
<i>Route pump emissions to new control device—production segment:</i>	
One diaphragm	7,971
Two diaphragm	4,234
Three diaphragm	2,988
Four diaphragm	2,366
<i>Route pump emissions to new control device—transmission and storage segment:</i>	
One diaphragm	6,101
Two diaphragm	3,241
Three diaphragm	2,287
Four diaphragm	1,811

^a For the production segment, the owners and operators realize the savings for the natural gas that is not emitted and not lost. The cost effectiveness values shown in this summary table do not consider these savings. If the EPA were to consider these savings, then the cost effectiveness figures in the table (\$/ton methane reduced) would reduce, which would mean the options assessed would be even more cost reasonable than already shown in this table.

As seen in tables 20 and 21, for sites without electricity with three diaphragm pumps, the cost effectiveness values for all options fall within the ranges typically considered reasonable by the EPA. Specifically, for new sources at production sites, the single-pollutant cost effectiveness of solar-powered electric controllers is \$395 per ton of methane and \$1,421 per ton of VOC. For compressed air systems driven by a generator, the single-pollutant cost effectiveness value for methane is \$1,857 per ton, which is considered reasonable, as are the multipollutant cost effectiveness values (\$929 per ton of methane and \$3,341 per ton of VOC).

For the transmission and storage segment, the single-pollutant methane cost effectiveness for solar-powered electric controllers is \$302 per ton and \$1,422 per ton for compressed air systems driven by a generator. These are both within the range considered reasonable for methane.

For existing sources without access to grid power, the methane cost effectiveness value for production sites with three diaphragm pumps is \$395 per ton for solar-powered electric pumps and \$2,048 per ton for compressed air systems powered by a generator. At transmission and storage sites, for the otherwise same sources

(existing sources without electricity, with three diaphragm pumps), methane cost effectiveness values are \$302 per ton for solar-powered electric pumps and \$1,567 per ton for compressed air systems powered by a generator. These values are all within the ranges considered reasonable for methane.

For sites without electricity with one or two diaphragm pumps, the cost effectiveness values for compressed air systems powered by a generator are not consistently within the range considered reasonable by the EPA. This leaves solar-powered electric pumps as the only option evaluated that has cost effectiveness values in the range

considered reasonable by the EPA for both the production and the transmission and storage segments. However, the EPA has some concerns about the technical feasibility of solar-powered pumps in some situations. Specifically, the Carbon Limits report, which was a reference the EPA relied upon for this analysis, states that “[s]ites with a large number of pumps or with pumps with high energy or power demand may represent a challenge for 100 percent solar-powered electric systems. In addition, shortly after completion, some wells may require high volumes of methanol injection, and powering pumps to inject this high volume can strain these systems.”³⁸³

While the EPA believes that solar-powered pumps are suitable for some applications, the EPA acknowledges concerns about their technical feasibility in some situations experienced at oil and gas sites. The EPA concluded that it is not appropriate to establish BSER based solely on solar-powered pumps. Therefore, the EPA created three subcategories: (1) Pumps at sites with access to electrical power, (2) pumps at sites without electrical service with three or more natural gas-driven diaphragm pumps, and (3) pumps at sites without electrical service with fewer than three natural gas-driven diaphragm pumps. The BSER determinations for these categories are discussed below. These determinations apply for both new and existing sources.

a. Pumps at Sites With Access to Electrical Power

The options evaluated for sites with electrical power are electric pumps and pneumatic pumps driven by compressed air systems. The EPA considers both of these options to be adequately demonstrated. For all scenarios at sites with electricity, the cost effectiveness values are within the range considered reasonable by the EPA (see tables 20 and 21). There could be secondary air impacts associated with the generation of the additional electricity, but those impacts are expected to be negligible. See the NSPS OOOOb and EG OOOOc TSD for this rulemaking for a discussion of these impacts. In conclusion, the EPA determined that a zero-emissions standard represents the BSER for pumps at sites with access to electrical power. This includes all diaphragm and piston pumps included in the affected facility at the site.

b. Pumps at Sites Without Electrical Service With Three or More Natural Gas-Driven Diaphragm Pumps

The options evaluated for sites without access to electrical power are solar-powered electric pumps and pumps driven by compressed air systems powered by a generator. As discussed above, the EPA considers pumps driven by compressed air systems powered by a generator to be adequately demonstrated. While the EPA recognizes the technical limitations of solar-powered pumps for some applications, the EPA finds that they are an option for many sites. For all scenarios where three or more diaphragm pumps are present at a site without electricity, the cost effectiveness values for both solar-powered pumps and compressed air systems are within the range considered reasonable by the EPA (see tables 20 and 21). There will be secondary air impacts associated with the use of generators, but based on a site-specific analysis, the EPA concludes that the benefits of the methane and VOC reductions outweigh the potential negative impacts. See section XI.D.2 of this document and the NSPS OOOOb and EG OOOOc TSD for this rulemaking for a discussion of these secondary air impacts from generators. While not shown here, for sites without access to electrical power that contain only piston pumps, the EPA did not identify any control options resulting in zero emissions that were considered cost effective. However, if a non-natural-gas zero-emissions system is installed to reduce diaphragm pump emissions, it would be cost effective to also use zero-emissions piston pumps. Therefore, the BSER determination for pumps at sites without access to electrical power and three or more diaphragm pumps is zero emissions of GHG (methane) and VOC. This is the BSER determination regardless of the number of piston pumps at the site. In conclusion, the EPA determined that BSER for pumps at sites with three or more diaphragm pumps without access to electrical power is zero emissions of methane and VOC from all diaphragm and piston pumps at the site.

c. Pumps at Sites Without Access to Electrical Power With Fewer Than Three Natural Gas-Driven Diaphragm Pumps

As discussed above, given the EPA’s conclusion that solar-powered pumps are not technically feasible for some common applications and the fact that the analysis did not show cost effectiveness values of a compressed air system powered by a generator to be

consistently within the range that the EPA considers reasonable at sites with fewer than three diaphragm pumps, the EPA concludes that a zero-emissions standard does not reflect the BSER for sites without access to electrical power that have fewer than three diaphragm pumps.

For this subcategory, the EPA evaluated other emissions control options, including routing the emissions to a process and routing the emissions to a combustion device. In most cases, a VRU will be required to enable the captured gas from the pump to be routed to a process. Therefore, costs were estimated for installing a closed vent system and VRU in order to route the gas to a process. It was assumed that this would achieve a 100 percent reduction in methane and VOC emissions. Costs were also estimated to install a closed vent system and a new combustion device to reduce the emissions, assuming a methane and VOC reduction of 95 percent. The EPA considers both routing emissions to a process and routing emissions to a combustion device to be adequately demonstrated emissions reduction techniques. As shown in tables 20 and 21, both options of routing emissions to a process via a new VRU or to a new combustion device have cost effectiveness values outside the ranges the EPA considers reasonable. Therefore, the EPA concludes that requiring the installation of a new VRU or control device for pumps at these sites is not the BSER.

The EPA also evaluated routing emissions through an existing VRU to a process (or routing directly to a process if that is possible) and routing emissions to an existing combustion device. Both of these options are adequately demonstrated since the emissions reduction technique is already being used for other equipment at the site. Further, the cost effectiveness of both options is in the range considered reasonable by the EPA. Therefore, the EPA concludes that, for sites without access to electricity and fewer than three diaphragm pumps, the BSER is routing to a process where an existing VRU is available or to a combustion device where an existing one is available.

d. Summary of Final Rule

Considering our revised analysis and BSER determinations, for affected and designated facilities at sites with access to electrical power and at sites without access to electrical power with three or more diaphragm pumps, the final rule and presumptive standard require these facilities to have zero GHG (methane)

³⁸³ Carbon Limits. (2016) Zero emission technologies for pneumatic controllers in the USA—Applicability and cost effectiveness. Available at https://www.carbonlimits.no/wp-content/uploads/2017/01/Report_FINAL.pdf.

and VOC emissions from all diaphragm and piston pumps. Zero emissions may be achieved either by using pumps not powered by natural gas (and thus not an affected or designated facility) or by routing natural gas-driven pump emissions through a CVS to a process. As explained in the December 2022 Supplemental Proposal, the EPA understands that emissions routed through a CVS to a process would achieve a 100 percent emissions reduction from the pumps and therefore would meet a zero-emissions VOC and GHG standard. Like what was included

in the supplemental proposal, the CVS demonstration requirements that there are no identifiable emissions from the CVS apply in the final rule. Unlike what was proposed, the final rule does not require a demonstration that using pumps not driven by natural gas is infeasible before compliance by routing emissions to a process is allowed.

For sites without access to electrical power with fewer than three diaphragm pumps, the final requirements are that natural gas-driven pump emissions must be routed through a CVS to a process if the site has a VRU, but if the site does not have a VRU, emissions can

be routed to an onsite control device that achieves a 95 percent emissions reduction. If there is no control device onsite that achieves a 95 percent emissions reduction, emissions must be routed to a control device(s) onsite that achieves less than a 95 percent emissions reduction. If no VRU or control devices are onsite, emissions from natural gas-driven pumps are not required to be controlled. A summary comparison of the emissions standards included in the December 2022 Supplemental Proposal and the final rule is included in table 22.

TABLE 22—COMPARISON OF PUMP NSPS STANDARDS AND EG PRESUMPTIVE STANDARDS BETWEEN THE SUPPLEMENTAL PROPOSAL AND THE FINAL RULE

Standard/presumptive standard	Supplemental proposal affected/designated facility site characteristics	Final rule affected/designated facility site characteristics	Difference(s)
Zero emissions	Sites with electricity	Sites with electricity and Sites with ≥3 diaphragm pumps.	Supplemental proposal required non-natural gas-driven pumps; final rule allows non-natural gas-driven pumps and/or routing pump emissions through CVS to a process and/or other control means that achieves zero emissions.
95 percent control	Sites without electricity and ≥4 diaphragm pumps.	No sites	95 percent emissions reduction required under supplemental proposal after demonstrations that it is technically infeasible to use non-gas driven pump, and to route emissions through a CVS to a process; 95 percent emissions reduction not directly required for any sites in the final rule.
Route emissions to existing control device.	Sites without electricity and <4 diaphragm pumps.	Sites without electricity and <3 diaphragm pumps.	Use of control device required under supplemental proposal after demonstrations that it is technically infeasible to use non-gas driven pump and to route emissions to a process; technical infeasibility demonstrations not required in final rule, but final rule requires routing emissions to a process if a VRU is onsite before a control device can be used.

It should be noted that there are similarities between the BSER analyses for natural gas-driven pumps and natural gas-driven process controllers. For both types of sources, the EPA evaluated a number of options that are not powered by natural gas and thus have zero methane and VOC emissions. As discussed above, for sites without access to electrical power with fewer than three diaphragm pumps, there are no cost-effective zero-emissions control options that the EPA found to be adequately demonstrated. For pumps at these sites, the only zero-emissions option with values the EPA considers to be cost-effective was solar-powered pumps. Given the power needs for some pumps to properly operate and the potential inadequacies of solar-powered systems to provide that amount of energy, the EPA determined that solar-powered systems do not represent BSER for pumps. Therefore, the EPA created a subcategory for sites without access to electrical power and fewer than three

pumps and established different emissions control requirements for that subcategory. In contrast, for controllers, there was more than one adequately demonstrated zero-emissions option evaluated for every sized model plant throughout the sectors with cost effectiveness values considered reasonable. Therefore, even if there are power limitations for solar-powered process controllers, which require much less energy than pumps to properly operate, there are other cost-effective zero-emissions options available, and consideration of other emissions control options or subcategories of process controller affected facilities was not necessary.

Comment: In the December 2022 Supplemental Proposal, the EPA proposed a hierarchy of emissions control requirements for sites that did not have access to electrical power. Under this approach, the EPA proposed that an owner or operator would be required to first evaluate pump options that do not use natural gas and provide

a certified demonstration that such options are infeasible before being allowed to use the next tier of emissions control options. For instance, at sites without access to electrical power, the proposal allowed for pump emissions to be routed to a process, but only after certified assessments were made demonstrating that it was technically infeasible to use solar-powered pumps and infeasible to use pumps powered by compressed air. One commenter stated that the EPA should remove the certifications associated with the hierarchy of pump compliance options. The commenter stated that the proposed certification requirements are unreasonably onerous because, in each case, the certifying individual must essentially prove a negative—that the otherwise applicable zero-emissions approaches are “technically infeasible.” The commenter stated that there is no definition of technical infeasibility in the proposed rule, but the words could be construed as setting an exceedingly

high bar, such that a given non-emitting technique is “infeasible” based solely on a technical assessment of whether it can theoretically be physically applied in the given situation, even though it could be inordinately expensive. According to the commenter, this outcome would not be lawful because it would violate the statutory requirement that BSER and the corresponding standard of performance must be cost-effective. The commenter added that a “technical infeasibility” standard allows for second-guessing by regulators or citizen enforcers, which invites a “battle of the experts” in potential enforcement actions. According to the commenter, this diminishes the possibility that the opt-outs can be implemented with reasonable certainty.

The commenter also reported that the express threat of possible personal liability on the part of certifiers will limit the number of individuals willing to make the needed certifications, particularly considering the uncertainties about what will be needed as a practical matter to demonstrate “technical infeasibility.” The commenter stated that the clear opportunity and possibility of second-guessing will be further material disincentives.

Response: In consideration of these comments, the EPA reviewed the proposed “certification of infeasibility” requirements. The EPA restructured the final standards for pumps based on comments received on the December 2022 Supplemental Proposal. The final rule no longer includes the complex hierarchy of technical feasibility demonstrations that was included in the December 2022 Supplemental Proposal. Instead, the final rule includes a subcategory based on clear criteria such that sources can be certain as to which emissions standards apply without demonstrations of technical infeasibility.

Comment: One commenter mentioned that the EPA proposed to allow operators to route natural gas-driven pump emissions to a control device, but only if the operators can demonstrate that routing to a process is technically infeasible and that it is infeasible to use pumps not driven by natural gas. The commenter urged the Agency to recognize the substantial investments that operators have already made to route emissions from pumps to control devices by allowing any natural gas-driven pump to be routed to controls—not only in situations where non-natural-gas technology and routing to a process are each technically infeasible.

Response: As explained above, for the final rule we have removed the

proposed requirement for demonstrations of technical infeasibility before the use of other equivalent control options may be used for pumps. In the final rule, we have further added the conditions under which pump emissions may be routed to a control device, which reflect our BSER determinations. For sites without access to electrical power and that have two or fewer diaphragm pumps, pump affected facility emissions may be routed to a control device if there is no VRU onsite.

2. Compliance Dates

Comment: Two commenters state that a 60-day compliance deadline for new/modified sources is unrealistic due to supply chain concerns, personnel shortages, and inflation. Due to supply chain shortages and disruption, one commenter reports that companies are experiencing backorders for some equipment, including non-natural-gas-driven pumps, generator skids, and air compressor skids, with current lead times ranging up to 12 months. The commenters note that there is no indication that this lead time will improve in the near future and believe it can be expected to worsen as owners and operators across the country increase demand in response to the final rule. One commenter recommended a compliance deadline of 12 to 26 months from the publication date of the final rule and one commenter proposed at least a 1-year timeframe for NSPS OOOOb compliance to allow for procurement and installation of the systems and equipment necessary (including labor necessary for installation).

One commenter requested that the EPA extend implementation timelines—particularly for sources that became NSPS OOOOb affected facilities prior to the date of final rule publication. The commenter remarked that until the effective date of NSPS OOOOb, some of these facilities would be unregulated under an existing NSPS or would begin operating as NSPS OOOOa affected facilities and may then need to complete retrofits to comply with newly applicable NSPS OOOOb standards. For example, the commenter states that NSPS OOOOa pneumatic pumps are not subject to a zero-emissions standard but would be subject to zero-emissions standards under NSPS OOOOb, requiring retrofit within 60 days after the final rule’s publication in the **Federal Register**. According to the commenter, this is not enough time to acquire retrofit equipment that will be in high demand, and likely short supply, as operators across the country place orders for equipment to meet the

zero-emissions standard. In addition, the commenter reports that operators must acquire engineering resources to engineer the installation of zero-emissions pneumatic systems. They report that these engineering resources, too, are likely to be in high demand and short supply. The commenter asserts that the timing of compliance obligations is particularly pronounced for pneumatic pumps, as according to the commenter, operators may no longer use pneumatic pumps that are driven by natural gas, subject to limited exceptions. The commenter notes that the November 2021 Proposal did not go so far as to eliminate the use of natural gas-driven pneumatic pumps entirely. The commenter states that operators may need to completely replace natural gas-driven pneumatic pumps that would have complied with the standards described in the November 2021 Proposal.

Response: Based on these comments, and for the same reasons explained in section XI.D.4 of this preamble for process controllers, the EPA is finalizing a NSPS compliance deadline for pumps required to meet a zero-emissions standard that allows for up to 1 year from the effective date of the final rule.

The equipment that owners and operators will need to comply with the final standard of zero emissions for pumps is, in some situations, the same equipment that owners and operators will need to comply with the final standard for process controllers. Based on comments, it appears that some equipment necessary for the installation of zero-emitting pumps may not be available quickly enough, and in large enough quantities, to enable new sources to comply with the final standard upon startup, or within 60 days after the publication of the final NSPS. As is the case for process controllers, the equipment types that the EPA believes are necessary to comply with the final zero-emissions standard for pumps in NSPS OOOOb are quite different from the type of equipment used to comply with the standards for these sources found in NSPS OOOOa. Due to these considerations, the EPA is not certain that new sources needing to meet the zero-emissions standard could obtain the equipment necessary to demonstrate compliance on the proposed timeline. This change to the final rule compliance timeline in NSPS OOOOb for pumps does not apply to sites without access to grid electricity that have fewer than three diaphragm pumps because those sites are not required to demonstrate zero emissions.

Until the final date of compliance with the zero-emissions standard,

owners/operators must demonstrate compliance with an interim standard which mirrors the requirements for pumps at sites without access to grid electricity that have fewer than three diaphragm pumps found at 40 CFR 60.5393b(b). In summary, the standards for these sites require that GHG and VOC emissions from all natural gas-driven pumps in the affected facility be routed to a process if a VRU is onsite. If a VRU is not onsite, emissions must be reduced by 95 percent if a control device with at least this emissions reduction capability is already available onsite or may be reduced by less than 95 percent if a control device is onsite but is not capable of reducing GHG and VOC emissions by 95 percent or more. As these requirements are similar to the current NSPS OOOOa requirements for pumps at well sites, owners/operators of new and recently modified or reconstructed sites subject to NSPS OOOOb will be able to readily obtain the equipment necessary for this interim standard, to the extent that equipment is even necessary. The only difference compared to NSPS OOOOa is that NSPS OOOOb requires emissions to be routed to a process if a VRU is already on the site. The information available to the EPA and provided by commenters does not suggest any equipment backlogs for common piping that may be needed to route emissions to a process through a VRU. Complying with the interim standard described above does not require using the equipment that commenters claimed they could not easily obtain (*i.e.*, the equipment needed to meet the zero-emissions standard). Therefore, the EPA expects no sites to have any problems complying with these interim requirements within 60 days after publication of the final rule. If an owner or operator opts to comply with the interim standard during the one year following publication of the final rule, then they must still comply with the final zero-emissions standard after the year has passed. Owners and operators can, and are encouraged to, comply with the final zero-emissions standard before the year has passed.

3. Recordkeeping and Reporting Requirements for Pumps Not Included in the Affected Source

Comment: Commenters pointed out that 40 CFR 60.5410b(g)(1) requires owners and operators to submit an identification of all pumps that are not powered by natural gas in the initial annual report required by 40 CFR 60.5420b(b)(10)(i), and such pumps are not part of the pumps affected facility definition. The commenters recommended that owners or operators

only be required to maintain records sufficient to determine compliance with the regulations. The commenters contend that having requirements for equipment that is not part of an affected source exceeds the EPA's authority granted under CAA section 111 and add that there is no environmental benefit to keeping or submitting information for equipment that cannot have emissions. The commenters recommended that the EPA remove any reporting or recordkeeping requirements for these pumps from the final regulations.

Response: After considering this comment, we have determined that it is appropriate in this instance to require identification of the equipment that is included in the affected facility, rather than the equipment that is not part of the affected facility. The pumps included in the affected facility are those that are subject to the emissions standards in the rule, whereas pumps not included in the affected facility are not subject to the emissions standards in the rule and also have no potential to emit methane or VOCs. Therefore, we have revised the recordkeeping requirements to require identification only of pumps that meet the finalized definition of an affected facility, which are those pumps that are driven by natural gas and that are in operation for 90 days or more in a calendar year.

4. Modification and Reconstruction Criteria and Requirements

Comment: Commenters requested that the EPA clarify that, for purposes of the collection of controllers or pumps at a site, a modification occurs only when a natural gas-driven pump is added. The commenters pointed out that the addition of a pump not driven by natural gas would not increase emissions from the affected source. Commenters also requested that the EPA clarify which pumps would be considered in the determination of whether a reconstruction has taken place.

Response: While it was our intention in the December 2022 Supplemental Proposal to only include the addition of natural gas-driven pumps in the conditions that would constitute a modification, as only those pumps could increase emissions, we agree that the proposed regulatory text did not specify this. We therefore have updated what we proposed for regulatory language to clarify that the addition of one or more natural gas-driven pumps to a site constitutes a modification. We also are clarifying in the final rule that reconstruction would be considered to occur whenever greater than 50 percent

of the number of existing onsite natural gas-driven pumps are replaced.

Comment: In addition to these clarifications regarding the criteria for determining whether a modification or reconstruction has taken place, one commenter stated that it is unclear how the notification requirements of 40 CFR 60.15 apply for reconstruction. The commenter noted that the proposed language in 40 CFR 60.5365b(d)(2)(ii) suggests that reconstructed natural gas-driven pumps would be subject to some of the requirements included in 40 CFR 60.15, which include 60-day notification and Administrator approval. According to the commenter, this conflicts with information presented in table 5 of the regulatory text, which states that 40 CFR 60.15(d) does not apply to pumps. The commenter believes it was the EPA's intent to not apply the additional notification and approval, given the number of facilities that will trigger reconstruction over time.

Response: We agree that we did not intend for facilities to be required to notify the Administrator of upcoming pump replacements that would constitute a reconstruction or for the Administrator to be required to review the notification and determine whether the replacements constitute a reconstruction. We have updated what we proposed for regulatory text to not refer to the requirements of 40 CFR 60.15(d) and have kept the information presented in table 5 of the proposed regulatory text, which states that 40 CFR 60.15(d) does not apply to pumps.

5. Change in Pneumatic Pump Terminology

In addition to the revisions to the modification and reconstruction criteria and requirements for pumps, to assist with avoiding possible confusion about which types of pumps are included within the definition of the affected facility and which types of pumps must be considered for purposes of the reconstruction and modification provisions, we have changed the terminology of "pneumatic pumps" (used in both the November 2021 Proposal and the December 2022 Supplemental Proposal) to simply "pumps" in the final rule. The EPA has made this change both in the final rule preamble and the final regulatory text. The term "pumps" is broader in scope because it includes pneumatic pumps as well as other types of pumps that are not pneumatic. Only a subset of pumps used by oil and gas facilities are pneumatic pumps that use pressurized air or gas to perform their functions. Other pumps might use electricity to

perform their functions. From a technical perspective, electronic pumps are not true “pneumatic” devices, but these electronic pumps can be used to achieve the zero-emissions standard. The EPA changed the terminology because we did not want to inadvertently convey that misimpression that pumps had to be pneumatic. To be clear, the final rule applies to the collection of natural gas-driven pumps. Pumps that are not driven by natural gas are not included in the affected facility. Further, only pumps driven by natural gas will be counted when determining whether a modification or reconstruction has occurred.

F. Wells and Associated Operations

In the December 2022 Supplemental Proposal, the EPA proposed to define a well affected facility, and well designated facility, to consist of a single well. The EPA also proposed standards for well affected facilities and designated facilities for oil wells with associated gas, gas wells that undergo liquids unloading, and wells that undergo completions. A summary of the comments received and the EPA’s response to these comments, including any changes made to the final rule, as applicable, are provided below. The EPA’s full response to comments on the November 2021 Proposal and December 2022 Supplemental Proposal, including any comments not discussed in this preamble, can be found in the EPA’s RTC document for the final rule.³⁸⁴

1. Well Affected Facility and Designated Facility Definitions

In the December 2022 Supplemental Proposal, rather than including three separate definitions for well affected facilities (as initially proposed in the November 2021 Proposal) for (1) oil wells with associated gas, (2) gas wells that undergo liquids unloading, and (3) wells that undergo completions, the EPA proposed a single definition for a well affected facility, which was defined as a single well, in the proposed NSPS OOOOb. A well is defined as a hole drilled for the purpose of producing oil or natural gas. The EPA proposed separate standards for well completions, associated gas from oil wells, and gas well liquids unloading operations, all or some of which could apply to a given

well affected facility. A well affected facility would be required only to comply with the standards that are applicable to the well. For example, a gas well would not be subject to the standard for oil wells with associated gas. The proposed NSPS OOOOb specified that a modification to an existing well occurs when the definition of modification in 40 CFR 60.14 is met, including when an existing well undergoes hydraulic fracturing or refracturing.

For the EG OOOOc rule, the EPA proposed, similar to NSPS OOOOb, a definition of well designated facility as a single well. Modification provisions do not apply under EG OOOOc. The December 2022 Supplemental Proposal included proposed presumptive standards for associated gas from oil wells and gas well liquids unloading. However, since the fracturing or refracturing of an existing well would constitute a modification under NSPS OOOOb, which would make the well a well affected facility under NSPS OOOOb, there would never be an existing well subject to well completion requirements and no requirements are specified for well completions under EG OOOOc. More discussion of the well affected facility/designated facility specific to each of the three associated well operations is provided in sections X.F.2, 3, and 4 of this document.

The EPA did not receive comments on the proposed definition of a well affected facility or designated facility that warranted changes to what was proposed in the December 2022 Supplemental Proposal. Therefore, the definitions have been finalized as proposed.

2. Associated Gas From Oil Wells

In section X.F.2 of this document, the final NSPS OOOOb and EG OOOOc requirements for oil wells with associated gas are summarized. The EPA received many comments on the December 2022 Supplemental Proposal on the following topics: the definition of associated gas, the BSER analysis for new wells, BSER for existing wells, temporary venting and flaring, and the infeasibility determination and certification. For each of these topics, a summary of the proposed rule, the comments, the EPA responses, and changes made in the final rule (if applicable), are discussed here. These comments and the EPA’s responses to these comments generally apply to the standards and presumptive standards in both the NSPS OOOOb and EG OOOOc respectively. The instances where the comment and/or response only applies to NSPS OOOOb or EG OOOOc are

noted. The EPA’s full response to comments on the November 2021 Proposal and December 2022 Supplemental Proposal, including any comments not discussed in this preamble, can be found in the EPA’s RTC document for the final rule.³⁸⁵

a. Definition of Associated Gas

Neither the November 2021 Proposal nor the December 2022 Supplemental Proposal included a definition of “associated gas.”

Comment: Several commenters³⁸⁶ suggested that a definition of “associated gas” be added. Commenters expressed that it is important for the EPA and the regulated community to have a common understanding of the definition of associated gas. One commenter added that, without a definition, the term “associated gas” could take on various meanings including the most literal interpretation of any gas associated with oil well production, which might include emissions from other NSPS OOOOb or EG OOOOc affected/designated facility types that the EPA regulates in other sections of its proposal—*e.g.*, a collection of fugitive emissions components or storage vessels. Commenters provided several suggestions for this definition, including:

- Associated gas means the gas that can be separated from the produced liquids in the first stage of separation at a pressure sufficient for it to flow into the gathering system.
- Associated gas means the natural gas which originates at wells operated primarily for oil production and occurs either in a discrete gaseous phase at the wellhead or is released from the liquid hydrocarbon during the initial stage of separation after the wellhead.
- Associated gas means the natural gas which originates at oil wells operated primarily for oil production and occurs either in a discrete gaseous phase at the wellhead or is released from the liquid hydrocarbon during the initial stage of separation after the wellhead.
- Associated gas means the natural gas evolved from hydrocarbon liquids during the initial stage of separation following production from the wellhead. Associated gas does not

³⁸⁴ *Standards of Performance for New, Reconstructed, and Modified Sources and Emissions Guidelines for Existing Sources: Oil and Natural Gas Sector Climate Review. Response to Public Comments on the November 2021 Proposed Rule and the December 2022 Supplemental Proposed Rule* (86 FR 63110, November 15, 2021; 87 FR 74702, December 6, 2022).

³⁸⁵ *Standards of Performance for New, Reconstructed, and Modified Sources and Emissions Guidelines for Existing Sources: Oil and Natural Gas Sector Climate Review. Response to Public Comments on the November 2021 Proposed Rule and the December 2022 Supplemental Proposed Rule* (86 FR 63110, November 15, 2021; 87 FR 74702, December 6, 2022).

³⁸⁶ EPA–HQ–OAR–2021–0317–2248, –2294, –2326, –2360, and –2428.

include natural gas associated with well completion or downhole well maintenance activities.

Response: The EPA agrees with the commenters that a definition of associated gas would be beneficial to provide clarity to regulatory and enforcement agencies and to the regulated community. First, our intention is to regulate the gas that is released from the liquid at the first stage of separation, so we included that characteristic in the definition in the final NSPS OOOOb and EG OOOOc.

One commenter suggested that the EPA define associated gas by using the phrase “in a discrete gaseous phase at the wellhead,” arguing that this description is necessary to avoid a broad interpretation of associated gas that encompasses any gas associated with oil well production. The EPA believes that the commenter’s suggested language is not necessary to clearly define associated gas and believes that it could add confusion.

We do not believe that the most literal interpretation offered by the commenter that any gas associated with oil well production might be considered associated gas, and we do not feel a need to include such a clarification in the definition. However, we recognize that there could be confusion between the emissions associated with well completions and associated gas. This is particularly the case in situations where a permanent separator has been placed onsite during the completion activities and used during the separation flowback stage. The definition of flowback in 40 CFR 60.5430b of the final rule specifies that the flowback period ends when either the well is shut in and permanently disconnected from the flowback equipment or at the startup of production. This provides a clear distinction between when the completion flowback requirements end and the associated gas production begins. Therefore, the final definition of associated gas includes the phrase, “Associated gas production begins at the startup of production after the flowback period ends.” The full definition of “associated gas” for this final rule is included below and can also be found at 40 CFR 60.5430b and 40 CFR 60.5430c.

Comment: One commenter³⁸⁷ requested that the EPA allow certain provisions for wildcat or delineation wells in its proposal with respect to the associated gas from oil well provisions. The commenter explains that such wells are exploratory in nature and are typically located in remote locations far

from any form of permanent infrastructure, including gathering infrastructure. Wildcat or delineation wells will typically only produce for a short period of time after flowback ends in order to complete well testing, which is used to determine the production flow rate along with other parameters such as the gas composition before the well is shut in or capped in accordance with state protocols. According to the commenter, in many instances an operator will not know or understand the composition of the gas until after the well is drilled. The commenter suggests that this combination of characteristics makes it impracticable to install gas gathering infrastructure or plan for other forms of beneficial use at a wildcat or delineation well. Noting that the EPA has exempted such wells from NSPS OOOOa standards for well completions, the commenter recommends that the EPA allow special considerations for handling associated gas since these activities are exploratory in nature and are typically not located near existing infrastructure.

Response: The EPA acknowledges that the types of associated gas wells that are the focus of these rule requirements are wells that consistently produce, and potentially emit, natural gas. The temporary nature of wildcat and delineation wells is not conducive to warrant the construction of piping to connect to a natural gas gathering system or to utilize another solution where the gas could be used. Further, as noted by the commenter, the owners and operators of wildcat or delineation wells typically do not have knowledge of the nature and composition of the gas until after the well is drilled, which further hinders the ability to implement a beneficial-use solution. Therefore, the EPA has clarified in the definition of associated gas that gas from wildcat or delineation wells, which are defined in 40 CFR 60.5430b, is not associated gas for purposes of regulation under NSPS OOOOb and EG OOOOc. In response to these comments, the final rule includes the following definition in 40 CFR 60.5430b and 40 CFR 60.5430c:

b. BSER Analysis for New Wells

In the November 2021 Proposal, the EPA determined that the BSER for associated gas was routing the associated gas from oil wells to a sales line. In the preamble for the November 2021 Proposal (86 FR 63236–39), and in the associated TSD, the EPA evaluated several equivalent options that would all effectively eliminate direct emissions of VOC and methane from associated gas, including routing the associated gas to a sales line, utilizing the associated

gas in a “beneficial” manner, and reinjecting the gas. Regarding the cost impacts of routing the gas to a sales line, the EPA assumed “that in situations where gas sales line infrastructure is available, there is minimal cost to owners and operators to route the associated gas to the sales line. While situations at well sites can differ, which would impact this cost, the EPA believes that in every situation the value of the natural gas captured and sold would outweigh these minimal costs of routing the gas to the sales line, thus resulting in overall savings.” 86 FR 63237. The EPA then concluded with, “Given the prevalence of this practice, the environmental benefit, and the economic benefits to owners and operators, the EPA concludes that BSER is routing associated gas from oil wells to a sales line.” 86 FR 63237. However, in 2021, the EPA also recognized that there are situations where there would not be access to a sales line and therefore also evaluated the costs and impacts of routing associated gas to a flare.

In the December 2022 Supplemental Proposal, the EPA again determined that BSER was routing the associated gas to a sales line and again proposed this requirement. The supplemental proposal also included that “[i]f access to a sales line is not available, the gas can be used as an onsite fuel source or used for another useful purpose that a purchased fuel or raw material would serve. If demonstrated that a sales line and beneficial uses are not technically feasible, the gas can be routed to a flare or other control device that achieves at least 95 percent reduction in methane and VOC emissions.” 87 FR 74710.

While no comments were received on the EPA’s earlier assertion in the November 2021 Proposal that there would be minimal cost to route the gas to an available sales line, comments were received on the flaring analysis. As a result of these comments, the EPA updated the flaring analysis in the December 2022 Supplemental Proposal. This updated flaring analysis assumed an initial capital cost of \$100,579 to install a new flare, which was the recommended cost provided by a commenter. Assuming a 7 percent interest rate and 10-year capital recovery period, along with an annual maintenance and operational cost of \$25,000, the estimated annual cost was \$36,044. Details of this cost estimate are included in the TSD for the December 2022 Supplemental Proposal.

The EPA also updated the analysis of the associated gas emissions in the December 2022 Supplemental Proposal because the analysis performed for the

³⁸⁷ EPA–HQ–OAR–2021–0317–2428.

November 2021 Proposal included emissions from associated gas wells that the EPA concluded were not representative of “routine” venting situations. The resulting analysis was a representative well with uncontrolled potential associated gas emissions of 343.6 tpy of methane and 96 tpy of VOC. The details of this analysis may also be found in the TSD for the December 2022 Supplemental Proposal.

Comments were received on the December 2022 Supplemental Proposal related to the representative baseline emissions analysis and the assumption that the costs of routing to a sales line or other beneficial use were minimal.

i. Baseline Emissions for Representative Well

Comment: One commenter³⁸⁸ stated that the EPA seemed to bias the data selected for baseline emissions to fit their expectation rather than using actual reported data. The commenter cited section 6.3.1 of the supplemental proposal TSD.

Response: In the TSD for the December 2022 Supplemental Proposal, the EPA identified 95 facilities/basins that reported associated gas venting emissions (through GHGRP subpart W data) for 2019. For each facility/basin, the number of wells venting is reported, along with the total methane vented from all wells. For each facility/basin, we calculated the average emissions per well. These average well emissions ranged from 0.015 tpy to over 2,400 tpy. Almost 20 percent of the facilities/basins had average well methane emissions lower than 0.2 tpy.

Explanations of the specific causes of emissions are not provided in the GHGRP subpart W outputs, but it would be expected that routine venting of associated gas would result in emissions greater than this level as the DOE indicates that the average associated gas production for an oil well is around 7.5 boe per day,³⁸⁹ which would be around 450 tons of methane emissions per year. In order to avoid selecting a well associated gas venting level that was unreasonably low, a weighted average well emissions level was calculated, using the total emissions from the facility/basin as the weighting factor. The result is an estimated average annual methane emissions level of 344 tpy. Applying the representative composition yields a representative VOC emissions level of 96 tpy.

The intention of the analysis that the commenter discusses was to develop an

emissions level estimate that represented the routine venting of associated gas—that is, situations where the associated gas was vented and not usually routed to a sales line or used for another purpose. As alluded to by the commenter, we assumed that the low emitting situations likely represent instances where venting was only temporary, and thus we discounted their contribution to the representative emissions level. As discussed in detail in section XI.F.2.f of this document, we recognized that the proposed rule did not adequately distinguish between “routine” and “temporary” situations. The final rule includes limited conditional allowances for venting in temporary situations where the associated gas is routed to a sales line normally (or used for another beneficial purpose) but due to circumstances or disruptions operators are not able to maintain normal operations without temporarily venting.

In conclusion, the EPA continues to believe that the associated gas emissions estimate levels used for the December 2022 Supplemental Proposal’s representative well appropriately characterizes a well that routinely vents the gas. Therefore, no changes were made to the representative well emissions level.

ii. BSER Cost Analysis

As noted earlier in this document, both in the November 2021 Proposal and in the December 2022 Supplemental Proposal, we assumed that there would be minimal cost to route the gas to an available sales line, which was determined to represent BSER.

Comment: In comments on the December 2022 Supplemental Proposal, one commenter³⁹⁰ stated that the associated gas model plant analysis did not include assumptions reflective of actual proposed requirements. They pointed out that none of the beneficial reuse emerging technologies were included in the model plant analysis, and that it was unclear how the EPA justified the inclusion of these technologies related to costs, feasibility, or environmental benefit/disbenefit.

Another commenter³⁹¹ also recognized that the EPA declined to quantitatively analyze the cost of routing to a sales line and the other beneficial use options, but the commenter provided a study³⁹² that included estimates of the costs of

various gas recovery options. Specifically, this study estimated the costs of routing to a sales line (pipeline gathering), onsite use (for fueling equipment or for local electricity generation), gas-to-wire, onsite compressed natural gas (CNG), onsite liquefied natural gas (LNG), and gas reinjection. Based on the cost data from this study, the commenter concluded that the cost effectiveness values for all abatement methods are well within the range that the EPA finds reasonable.

Response: While the first commenter indicated that the EPA did not perform an analysis of the BSER options, the commenter did not provide any information to support their comments. Contrary to this comment, the EPA did perform a BSER analysis. The EPA found the study provided by the second commenter to be informative regarding the extent of flaring in the U.S. and fundamental considerations in non-flaring abatement options. However, we closely examined this information and determined that the basis for these cost estimates lacked some details that the EPA thought necessary in order to use them as the basis for a BSER analysis. See EPA-HQ-OAR-2021-0317-2433 attachment T to review the data submitted.

In addition to following up with the single commenter that provided cost information for non-flaring options,³⁹³ the EPA performed a search for cost information from other sources. One source identified with detailed cost information that the EPA found to be informative was a study performed by ICF International for the Interstate Natural Gas Association of America (INGAA) Foundation.³⁹⁴ In addition to a plethora of information regarding midstream infrastructure, this study included detailed costs for the installation of gathering and boosting systems and associated lines. Specifically, it provided detailed cost information for, among other things, pipeline costs and compression/pumping costs. The gathering pipeline costs were provided starting in 2010 and projected to 2035 for pipe sizes ranging from 2 inches to 30 inches. In conversations with the authors of this

³⁹³ Please see June 5, 2023, meeting memorandum for meeting between the EPA and EDF and Rystad in EPA-HQ-OAR-2021-0317.

³⁹⁴ *North America Midstream Infrastructure through 2035 Significant Development Continues*. The INGAA Foundation, Inc. Prepared by ICF. June 18, 2018. Available at: <https://ingaa.org/north-america-midstream-infrastructure-through-2035-significant-development-continues/>.

³⁸⁸ EPA-HQ-OAR-2021-0317-2428.

³⁸⁹ https://www.eia.gov/petroleum/wells/pdf/full_report.pdf.

³⁹⁰ EPA-HQ-OAR-2021-0317-2428.

³⁹¹ EPA-HQ-OAR-2021-0317-2433.

³⁹² Rystad Energy. “Cost of Flaring Abatement, Final Report.” January 31, 2022.

report,³⁹⁵ the commenter indicated that the most representative pipe sizes for connecting a well to an existing gathering system were either 4 or 6 inches.

This information was used to estimate the costs for connecting the associated gas from a well site to a nearby

gathering system/sales line for the representative well discussed earlier in this document. Specifically, costs were estimated for both 4- and 6-inch pipe sizes and for a variety of distances, in miles, to the gathering system. Other assumptions in this analysis were that the compressor horsepower needed was

25 horsepower and the capital recovery was based on 7 percent interest rate and 10 years. Annual operation and maintenance costs were estimated to be 25 percent of the total capital costs. Table 23 provides the results of this analysis.

TABLE 23—NSPS COST ANALYSIS FOR ROUTING ASSOCIATED GAS TO SALES LINE FOR REPRESENTATIVE NEW WELL ^a

Pipe size (inches)	Length (miles)	Cost effectiveness (\$ per ton of emission reduction)							
		Without considering savings				Considering savings			
		Single pollutant		Multipollutant		Single pollutant		Multipollutant	
		Methane	VOC	Methane	VOC	Methane	VOC	Methane	VOC
4	1	\$158	\$569	\$79	\$285	Net Savings	Net Savings	Net Savings	Net Savings
4	3	257	926	129	463	59	213	38	137
4	5	357	1,283	178	641	158	570	88	315
4	7	456	1,640	228	820	258	927	137	494
4	10	604	2,175	302	1,087	423	1,522	212	761
4	20	1,100	3,958	550	1,979	919	3,306	459	1,653
4	30	1,596	5,742	798	2,871	1,415	5,090	707	2,545
4	40	2,092	7,526	1,046	3,763	1,910	6,873	955	3,437
4	50	2,587	9,310	1,294	4,655	2,406	8,657	1,203	4,329
6	1	171	615	85	307	Net Savings	Net Savings	Net Savings	Net Savings
6	3	295	1,062	148	531	97	349	57	205
6	5	420	1,510	210	755	222	797	119	429
6	7	544	1,957	272	979	346	1,244	181	652
6	10	731	2,629	365	1,314	549	1,976	275	988
6	20	1,353	4,867	676	2,433	1,171	4,214	586	2,107
6	30	1,975	7,104	987	3,552	1,793	6,452	897	3,226
6	40	2,597	9,342	1,298	4,671	2,415	8,690	1,208	4,345
6	50	3,219	11,580	1,609	5,790	3,037	10,927	1,519	5,464

^a The representative well has associated gas methane emissions of 343.6 tpy and VOC emissions of 95.5 tpy.

As provided in table 23, the single-pollutant cost effectiveness for methane ranges from \$158 to \$3,219 per ton of methane emissions eliminated. If the value of the gas that will be sold (*i.e.*, the savings) is considered, the range is from a net savings to \$3,037 per ton. The per-ton VOC cost effectiveness ranges from \$569 to \$11,580 without savings and ranges from a net savings to \$10,927 considering the savings. The multipollutant cost effectiveness values range from \$79 per ton of methane and \$286 per ton of VOC to \$1,609 per ton of methane and \$5,790 per ton of VOC. If savings are considered, these multipollutant cost effectiveness values range from a net savings to \$1,519 per ton of methane and \$5,464 per ton of VOC. More details on this analysis are provided in the 2023 NSPS OOOOb and EG OOOOc Final Rule TSD.

The EPA determines that the estimated costs, for both pipe sizes for distances out to 50 miles are reasonable, when considering multipollutant reductions of methane and VOC. The EPA factors in that owners and operators of newly drilled wells have the flexibility to plan and coordinate the construction of gas gathering systems

even over extended distances. Our analysis shows that constructing up to 50 miles of pipeline is a cost-effective means of managing associated gas at representative volumes of gas. In cases where the cost of construction of gathering line or gas volume differs significantly from these representative parameters, the other options for managing associated gas are available under the standards. The information presented in table 23 supports the assumption that the EPA made in the November 2021 Proposal and the December 2022 Supplemental Proposal that routing to a sales line is cost-effective.

c. BSER Conclusion for New Sources

In the December 2022 Supplemental Proposal, we concluded that BSER was routing the associated gas to a sales line. In addition, we recognized that there were other options that achieved the same level of emissions reduction as routing to a sales line. Therefore, we proposed four compliance options to reduce emissions of methane and VOC from associated gas from new oil wells. These options were: (1) recover the associated gas from the separator and

route the recovered gas into a gas gathering flow line or collection system to a sales line, (2) recover the associated gas from the separator and use the recovered gas as an onsite fuel source, (3) recover the associated gas from the separator and use the recovered gas for another useful purpose that a purchased fuel or raw material would serve, or (4) recover the associated gas from the separator and reinject the recovered gas into the well or inject the recovered gas into another well for enhanced oil recovery.

Routing associated gas to a sales line is an adequately demonstrated method of emissions reduction. This is supported by the statements of one industry commenter,³⁹⁶ which indicated that recovering associated gas from the separator and routing the recovered gas into a gas gathering flow line or collection system to a sales line “explains standard business operations for thousands of wells producing a vital energy resource throughout the country.” They add that “[s]elling natural gas is part of our business.” The environmental benefit of routing associated gas to a sales line is significant, as there are no GHG

³⁹⁵ See EPA Docket EPA-HQ-OAR-2021-0317 for record of June 21, 2023, call with INCAA Foundation/ICF.

³⁹⁶ EPA-HQ-OAR-2021-0317-2428.

(methane) or VOC emissions. As outlined in the TSD for this final rule, there are also minimal nonair quality health and environmental impacts related to routing gas into a sales line. Further, as discussed in section XI.F.2.b of this document, in response to comments, the EPA obtained information related to the costs of connecting to a sales line and performed an analysis, the results of which showed that the cost of routing to sales is reasonable given the emissions reductions. Given these considerations, the EPA again concludes that BSER is routing associated gas from oil wells to a sales line. In addition, the EPA continues to accept that the other three options proposed achieve equivalent emissions reductions to routing to a sales line and that they should be allowed as regulatory alternatives to the BSER.

The December 2022 Supplemental Proposal for new sources allowed the associated gas to be routed to a flare or control device that reduces methane and VOC emissions by at least 95.0 percent if a determination was made that it was not technically feasible to route the associated gas to a sales line, use it as onsite fuel or for another beneficial purpose, or inject/reinject it due to technical or safety reasons, and the determination was certified by a professional engineer or another qualified individual with expertise in the uses of associated gas. Ongoing, continuous flaring in the absence of a method for capturing and selling, putting to beneficial use, or storing associated gas is referred to as “routine” flaring. As described previously in this preamble and in response to comments described below, the EPA has changed these provisions for the final NSPS OOOOb rule to specify that routine flaring is disallowed at new wells that commence construction 24 months after the effective date of this final rule. As discussed in detail below, new sources can take this requirement into account when planning. Moreover, the final rule provides for an orderly “phase in” of this requirement through compliance deadlines that vary based on the date of construction, and it also recognizes reasonable exemptions for temporary or emergency uses of flaring. These requirements for new wells reflect comments and information the EPA received in response to the December 2022 Supplemental Proposal.

Comment: Numerous commenters supported the EPA’s proposal to allow for multiple compliance options as alternatives to routing gas to a sales line, and several pointed out that the proposed list was consistent with the

options allowed in New Mexico and Colorado. For instance, one commenter³⁹⁷ stated, “As in the EPA’s supplemental proposal, Colorado and New Mexico require operators to capture associated gas from oil wells and either route the gas to a sales line or put it to an alternative use. The alternative uses allowed in New Mexico largely overlap with those included in the EPA’s supplemental proposal and include, among other things, power generation on lease, liquids removal on lease, reinjection for underground storage, and other alternative uses approved by the division. For wells that are not connected to a pipeline, Colorado similarly allows operators flexibility to use other options to capture gas including to generate electricity or to process the gas to recover natural gas liquids, without venting or flaring.”

The commenter³⁹⁸ also recommended that the EPA remove any specific reference to “enhanced oil recovery.” The commenter explained that other preferable options exist for injected or reinjected gas, such as permanent storage in porous geological formations, and there is no reason to disallow or subordinate these alternatives.

Response: The EPA agrees with this comment and therefore has eliminated specific reference to enhanced oil recovery in the final rule for both NSPS OOOOb and EG OOOOc. Specifically, the fourth compliance option (alternative standard) under the final rule allows the recovery of associated gas from the separator and reinjection into the well or injection into another well. Removal of reference to enhanced oil recovery means that sources can choose to reinject regardless of whether doing so results in additional oil being produced or recovered from the well. This compliance option still results in equivalent emissions reductions to the BSER.

Comment: Many commenters objected to the allowance of routine flaring for new sources. One commenter³⁹⁹ urged the EPA to eliminate pollution from routine flaring except in emergency situations and to define the term “emergency” clearly and narrowly. The commenter recommended that exemptions only be applicable to short-term and temporary flaring. Another⁴⁰⁰ suggested that routine flaring from new wells can never be justified due to the technical infeasibility of some alternative. The commenter stated that

routine flaring is readily preventable at new wells with proper planning and coordination. Another commenter⁴⁰¹ urged the EPA to adopt NSPS and EG that effectively prohibit routine flaring of associated gas from new and existing oil wells, with the only exceptions related to safety and emergencies, by requiring owners or operators to capture all or most of the gas. Another commenter⁴⁰² strongly supported the EPA’s proposed requirement that owners and operators of oil wells with associated gas must capture that gas and route it to a sales line. However, they stated the belief that the EPA can and should take further steps to eliminate routine flaring. They asserted that the EPA should replace the broad technical infeasibility exception that would allow operators to continue routinely flaring with narrowly defined exemptions applicable only to short-term and temporary flaring. Another commenter⁴⁰³ called for a nationwide ban on routine flaring, characterizing the practice as wasteful and unnecessary. The commenter points out that leading state examples and the commitments made by multiple operators demonstrate that eliminating routine flaring is feasible and cost-effective.

The commenter noted that numerous operators have committed to eliminate routine flaring as part of the World Bank’s “Zero Routine Flaring by 2030” initiative. To date, 54 oil companies and 34 governments have endorsed the “Zero Routine Flaring by 2030” initiative. Based on satellite estimates and publicly reported flaring data, together the endorsers represent approximately 60 percent of global flaring. The commenter added that ExxonMobil “recently announced a commitment to end routine flaring while also expressing support for regulations banning this wasteful practice.” They urged the EPA to revise its proposal to prohibit routine flaring by requiring that operators use one of the four gas recovery abatement methods included in the EPA’s proposal. They suggested that the EPA allow for flaring only during explicit, narrowly tailored, and time-limited exemptions. They believed that doing so would more clearly and unequivocally prohibit pollution stemming from routine flaring, as well as enhance the enforceability of the rule.

³⁹⁷ EPA-HQ-OAR-2021-0317-2433.

³⁹⁸ EPA-HQ-OAR-2021-0317-2433.

³⁹⁹ EPA-HQ-OAR-2021-0317-2394.

⁴⁰⁰ EPA-HQ-OAR-2021-0317-2433.

⁴⁰¹ EPA-HQ-OAR-2021-0317-2410.

⁴⁰² EPA-HQ-OAR-2021-0317-2392.

⁴⁰³ EPA-HQ-OAR-2021-0317-2408.

One industry commenter⁴⁰⁴ reported that it is actively working to reduce flaring of associated gas across each of its operating areas and has committed to eliminate routine flaring by 2030. Since the commenter's standard practice is to only bring wells online where adequate sales line capacity exists, the commenter supports the restriction of the routine flaring of associated gas from oil wells that are considered "new" sources.

Commenters also pointed out that Colorado and New Mexico do not allow the long-term routine flaring of associated gas. One⁴⁰⁵ recommended that the EPA should follow the lead of these states and prohibit routine flaring of associated gas from new and existing oil wells except in very limited cases such as emergencies and for safety reasons.

One commenter⁴⁰⁶ stated that a standard based on approaches like those adopted in Colorado and New Mexico, which clearly limit and delineate circumstances where temporary flaring would be permitted, represents the "best system" for several reasons. For one, it would require gas recovery but contain reasonable exemptions for temporary flaring during certain activities that may require flexibility to vent or flare. Thus, this system would "reduc[e] emissions as much as practicable" and reflect the "maximum practicable degree of control." The standard would permit technological flexibility by allowing the use of a multitude of abatement methods, including routing to a sales line, injection, or reinjection, use as onsite fuel, or use for another alternative purpose. The commenter pointed out that the costs of a capture standard are reasonable, cost-effective, and in some instances even profitable for operators.

Response: The EPA finds these arguments for not allowing routine flaring under any circumstance for new sources to be compelling. The EPA reviewed the comments from across the industry on our proposal to direct the gas to a sales line or adopt another gas management technique that did not require flaring. The conclusion that the EPA reached for new sources was that operators did not demonstrate or even explain that routing to a sales line or the alternatives were infeasible, only that specific circumstances could make certain alternatives more attractive than others. The most cited factors for deciding between the proposed alternatives were the logistics of each

option and the costs of adopting any method as a function of the amount of available gas and whether the well was new, existing, or a marginal well nearing the end of production. Since the objective of our proposal was to cost-effectively minimize the emissions that result from associated gas, and flaring emits more than the zero-emissions options, we looked at the group of wells where the factors allowing a non-flaring option were most in favor of operators. New wells fit the criteria where factors worked most in favor of not flaring. New wells benefit from new investment and the benefit of planning to accommodate each option best suited to the site. Production is highest at startup, meaning that from the start of production a new well would have anywhere from 10 to 30 years of production to draw upon to manage and amortize the investment required to manage associated gas. Our analysis of the costs of connecting to a sales line indicated that for representative amounts of gas at reasonable distances, the outlook for amortization of the capital investment was reasonable. See table 22 above. Where distances or logistics might make connection to sales lines less attractive, commenters provided cost and qualitative support that the other alternatives would likely be used rather than connecting to sales, provided they had the benefit of space and time to plan for managing the associated gas when construction was beginning. As mentioned above, companies themselves have made voluntary commitments to eliminate flaring in the near future, by 2030.⁴⁰⁷ While those commitments are on a longer time horizon than this final rule, our decision to limit the prohibition on routine flaring to only new wells means the timelines between implementation of the NSPS and the voluntary commitments are in the range of about 4 years apart (considering the phase-in period for the final associated gas standards in the NSPS). We heeded industry comments that a significant time horizon would be required to make such a transition, and we chose 24 months from the effective date of the final rule as the most flexible option that would provide meaningful and timely reductions without disrupting the near-term investments taking place now. We concluded that, for new sources, opportunities exist for advance planning to route the associated gas to

a sales line, use it as onsite fuel or for another beneficial purpose, or inject/reinject it. Therefore, in the final rule, the EPA has eliminated the allowance for new sources that associated gas can be routinely routed to a flare or other control device. As explained further below, the EPA is finalizing a phase-in approach for this standard for the NSPS OOOOb.

As discussed in section XI.F.2.f of this document, the EPA recognizes that a source routing the associated gas to a sales line, using it as onsite fuel or for another beneficial purpose, or injecting/reinjecting it will likely encounter temporary situations where it is infeasible or unsafe to route the associated gas to a sales line, use it as onsite fuel or for another beneficial purpose, or inject/reinject it. Therefore, the final rule allows temporarily routing to a flare or other control device in specified situations.

In addition, the EPA acknowledges that owners or operators may have already planned and initiated efforts to drill new wells based on the allowance of routing to a flare or control device with an infeasibility determination that was included in the December 2022 Supplemental Proposal. The EPA also accepts that existing wells that are modified or reconstructed may be limited in the options to route to a sales line or comply with one of the other options. Therefore, the final rule includes special allowances for these situations. This is discussed in section XI.F.2.d of this document.

d. Considerations for New Sources for Which Construction Commenced Prior to the Final Rule and for Reconstructed and Modified Sources

In the December 2022 Supplemental Proposal, the EPA proposed to allow new sources to routinely route associated gas to a flare or control device with a demonstration and certification that routing the associated gas to a sales line, using it as onsite fuel or for another beneficial purpose, or injecting/reinjecting it was infeasible for technical or safety reasons. A new source is defined as a well that commenced construction, reconstruction, or modification after December 22, 2022. Further, the definition of "commenced" found within 40 CFR 60.2 applies for purposes of NSPS OOOOb. That definition states that "commenced means . . . that an owner or operator has undertaken a continuous program of construction or modification or that an owner or operator has entered into a contractual obligation to undertake and complete, within a reasonable time, a continuous

⁴⁰⁷ To date, 54 oil companies and 34 governments have endorsed the "Zero Routine Flaring by 2030" initiative. See "Global Initiative to Reduce Gas Flaring: "Zero Routine Flaring by 2030," EPA Docket ID EPA-HQ-OAR-2021-0317.

⁴⁰⁴ EPA-HQ-OAR-2021-0317-2360.

⁴⁰⁵ EPA-HQ-OAR-2021-0317-2410.

⁴⁰⁶ EPA-HQ-OAR-2021-0317-2433.

program of construction or modification.”

As discussed in section XI.F.2.c of this document, the EPA believes that, with the full knowledge and understanding of the final rule, owners planning on drilling new wells in the future have the ability to plan ahead to ensure that the associated gas is routed to a sales line, used as onsite fuel or for another beneficial purpose, or injected/reinjected. However, the EPA acknowledges that new wells have commenced construction in the period between December 22, 2022, and the date of publication of this final rule, and that it is reasonable for owners and operators of such wells to have assumed that the final rule could have continued to allow the proposed allowance to routinely flare the associated gas or route it to a control with an infeasibility determination and certification. The EPA concludes that for wells in this situation, it is appropriate to allow the associated gas to be routinely routed to a flare or control device with a determination and certification that it is technically infeasible⁴⁰⁸ to route the associated gas to a sales line, use it as onsite fuel or for another beneficial purpose, or inject/reinject it. The EPA encourages owners and operators of these sources to continue to seek opportunities to route the associated gas to a sales line, use it as onsite fuel or for another beneficial purpose, or inject/reinject it. These methods will not only eliminate the environmental impacts of routine flaring but will also significantly reduce the compliance burden on the owners and operators. Therefore, the final rule allows sources that have made the requisite determination and certification to route the associated gas to a flare or control device that achieves a 95.0 percent reduction in VOC and methane emissions for those wells for which construction was commenced between December 22, 2022, and the effective date of the final rule, which is May 7, 2024. This is only allowed with a demonstration and certification that it is technically infeasible to route the associated gas to a sales line, use it as onsite fuel or for another beneficial purpose, or inject/reinject it. This demonstration and certification must then be renewed annually. See section

⁴⁰⁸ As discussed in section XI.F.2.g of this document, based on comments, the EPA determined that the need to flare associated gas due to safety reasons is a temporary circumstance and would not result in the need to routinely flare in place of routing the associated gas to a sales line, using it as onsite fuel or for another beneficial purpose, or injecting/reinjecting it. Therefore, temporary flaring due to safety reasons is allowed without any type of infeasibility determination or certification.

XI.F.2.g of this document for a discussion of comments received on the infeasibility determination and certification process and the requirements contained in the final rule.

The EPA recognizes that existing sources that undergo reconstruction or modification and thus become new sources also face different circumstances than new wells for which construction commences with full knowledge of the “no routine flaring” requirement in the final rule. These wells were likely originally drilled without the expectation that the EPA would be proposing and promulgating requirements that would require the routing of associated gas to a sales line, using it as onsite fuel or for another beneficial purpose, or injecting/reinjecting it as required by the final rule. The location of these existing wells that are undergoing reconstruction or modification is established and the owner or operator does not have the ability to move the well to allow connection more easily to a sales line, to inject into another well, or perhaps to utilize any other option. Therefore, the EPA concluded that it is appropriate to allow wells reconstructed or modified after December 22, 2022, to routinely flare associated gas or route it to control with a technical infeasibility determination and certification. This demonstration and certification must then be renewed annually.

Finally, the EPA acknowledges that owners and operators could have initiated the planning stages of a new well based on the December 2022 Supplemental Proposal even though they may not have specifically undertaken the activities that meet the definition of “commenced construction.” Therefore, owners and operators may have made preliminary plans assuming that flaring or routing to control would be allowed with a determination that it is technically infeasible to route the associated gas to a sales line, use it as onsite fuel or for another beneficial purpose, or inject/reinject it. The final rule allows sources that commence construction within a certain period after the effective date of the rule to routinely route the associated gas to a flare or to a control device for a short period, after which they are required to route the associated gas to a sales line, use it as onsite fuel or for another beneficial purpose, or inject/reinject it. This will allow owners and operators to proceed with plans, but also not allow routine flaring or routing to control for an extended period. Specifically, the final rule allows wells for which construction commences between May 7, 2024 and May 7, 2026

to route the associated gas to a flare or to a control device that achieves a 95.0 percent reduction in VOC and methane emissions, with the proper demonstration of technical infeasibility, until May 7, 2026. Routine flaring for these sources is only allowed with a demonstration and certification that it is technically infeasible to route the associated gas to a sales line, use it as onsite fuel or for another beneficial purpose, or inject/reinject it. This demonstration and certification must then be renewed annually. After May 7, 2026, these sources will no longer be able to routinely flare associated gas, and must route the associated gas to a sales line, use it as onsite fuel or for another beneficial purpose, or inject/reinject it. For information regarding technical infeasibility demonstrations, including examples, see section X.F.2.a.i. of this document.

e. BSER for Existing Sources

In the December 2022 Supplemental Proposal, the EPA proposed presumptive standards for associated gas from existing oil wells for the EG OOOOc that mirrored those for new sources under NSPS OOOOb. That is, EG OOOOc included four compliance options to eliminate emissions of methane from associated gas from existing oil wells. These options were: (1) recover the associated gas from the separator and route the recovered gas into a gas gathering flow line or collection system to a sales line, (2) recover the associated gas from the separator and use the recovered gas as an onsite fuel source, (3) recover the associated gas from the separator and use the recovered gas for another useful purpose that a purchased fuel or raw material would serve, or (4) recover the associated gas from the separator and reinject the recovered gas into the well or inject the recovered gas into another well for enhanced oil recovery. Associated gas was allowed to be routed to a flare or other control device if the owner or operator demonstrated that all four options were infeasible due to technical or safety reasons and if that demonstration is approved by a certified professional engineer or other qualified individual.

Comment: One commenter⁴⁰⁹ suggested that there was a fundamental flaw in the EPA’s process that has resulted in a misguided BSER determination for existing sources that effectively regulates existing sources the same as new and modified sources. Another commenter claimed that the EPA’s recurring conclusion that

⁴⁰⁹ EPA-HQ-OAR-2021-0317-2294.

designated facilities under the EG should be the same as affected facilities under the NSPS did not recognize the differences between new and existing sources.⁴¹⁰

Response: The EPA generally agrees with the commenters that consideration must be given to any meaningful differences between new and existing sources in determining the respective BSER. The EPA proposed that routing the associated gas from existing wells to a sales line was an adequately demonstrated method of emissions reduction and the costs were reasonable. We also determined that the other equivalent compliance options also were appropriate for existing sources (we did not identify any limitations that would universally inhibit use of the alternatives for existing sources). We recognized that there could be situations where it was infeasible to comply with one of these options, so the proposed presumptive standards in EG OOOOc included the allowance to routinely flare the associated gas or route it to control if it was demonstrated and certified that the earlier listed four alternatives were infeasible due to technical or safety reasons.

As discussed in section XI.F.2.c of this document, the final rule will phase out the option for new sources to routinely route the associated gas to a flare or control device. In addition, numerous comments were submitted regarding considerations related to wells that produce low levels of associated gas. In light of the changes to the NSPS and comments received specific to

existing sources of associated gas, the EPA reevaluated the BSER for existing sources. This revised BSER analysis for existing sources recognizes that, unlike new sources, existing sources may not have taken into account distance to a gas line when choosing their location and cannot readily do so now.⁴¹¹

Comment: Commenters⁴¹² believed that the EPA needs to maintain flaring as an option for wells with little associated gas. They maintained that the gas production rate is too low to be able to justify the expense of routing to a sales line or even investing in the equipment to inject the gas back into the reservoir. Many times, the gas production rate is too low to be able to reliably operate an engine to produce power to operate surface equipment. They added that low production wells need to have the option to flare the gas as an environmentally acceptable option. The commenters believed that eliminating this option would be an unnecessary burden on small businesses.

The commenters pointed out that much of the associated gas from low production wells does not meet the requirements to be sold on an interstate pipeline system. The gas may require water, nitrogen, CO₂, and heavier hydrocarbons (ethane, propane, butane, pentane, and hexane) to be removed prior to its being sold into the gas market. The cost to make the gas “pipeline spec” usually exceeds the benefit of selling the gas on the pipeline. The commenters provided that this is another example where low production

wells should be exempt from the proposed regulation.

Another commenter⁴¹³ explained that, for many of their existing wells, no sales line is readily available, and even if one was available, the volume of associated gas may be too low to reach a sales line. The commenter recommended that the EPA reconsider this requirement for existing well sites, in recognition that the infrastructure is unlikely to be present to make such a requirement feasible.

Yet another commenter⁴¹⁴ recommended that the EPA maintain an exemption for low production wells. The commenter explained that many of the low production wells operate with low pressure and low gas-to-oil ratios, so the PTE is significantly less than the PTE for higher-production wells that were recently drilled.

Response: As discussed in section XI.F.2.b of this document, the EPA obtained data and performed a cost analysis of collecting the associated gas and routing it to a sales line for a representative new well. As discussed, this representative new well had methane emissions of 343.6 tpy. In response to the comments regarding low associated gas production wells, the EPA performed an analysis for varying baseline emissions levels and distances to the gathering system. Specifically, the EPA evaluated the costs of routing associated gas to a sales line for distances up to 5 miles using a 4-inch pipe. The results of this analysis are provided in table 24.

TABLE 24—METHANE COST ANALYSIS OF ROUTING TO SALES LINE FOR LOW ASSOCIATED GAS PRODUCTION WELLS

Associated gas methane emissions (tpy)	Miles from gathering system cost effectiveness (\$/ton methane reduced)				
	0.25	0.50	1	3	5
10	\$3,961	\$4,387	\$5,239	\$8,646	\$12,053
20	1,882	2,095	2,520	4,224	5,927
30	1,188	1,330	1,614	2,750	3,886
40	842	948	1,161	2,013	2,865
50	634	719	889	1,571	2,252
60	495	566	708	1,276	1,844
70	396	457	579	1,065	1,552
80	322	375	481	907	1,333
90	264	311	406	785	1,163
100	218	260	346	686	1,027

Based on the results of this analysis, the EPA decided it was appropriate to separate existing oil wells with associated gas into two subcategories. For wells with 40 tpy of methane

emissions, the cost effectiveness of routing to sales was considered reasonable at distances in a range of about 3 miles. We assume that the methane emissions are equivalent to the

amount of methane contained in the associated gas. Therefore, the two subcategories are those with associated gas that contains 40 tpy or less methane and those that contain greater than 40

⁴¹⁰ EPA-HQ-OAR-2021-0317-2446.

⁴¹¹ See full BSER analysis in chapter 4 of the final TSD for this rulemaking.

⁴¹² EPA-HQ-OAR-2021-0317-2168 and -2172.

⁴¹³ EPA-HQ-OAR-2021-0317-2283.

⁴¹⁴ EPA-HQ-OAR-2021-0317-2172.

tpy methane. The EPA then developed BSER separately for these two subcategories.

i. BSER for the Subcategory of Wells With Associated Gas Containing 40 tpy or Less Methane

For wells that produce 40 tpy or less of associated methane gas, the analysis shows that, depending on the distance from the well to the gathering system, it could sometimes be cost-effective to route the associated gas to a sales line, and sometimes not. Assuming that there is an existing flare or control device onsite that could accept the associated gas, the cost to direct the associated gas into the flare would be minimal (approximately \$6,100 capital cost, with an annual cost of \$670). The cost effectiveness of routing to an existing flare for an associated gas well where the associated gas contains 40 tpy of methane is \$18 per ton of methane, which is well within the range that the EPA has considered reasonable. In fact, the cost effectiveness for wells with 1 tpy of methane (\$915/ton) is still reasonable. For the installation of a new flare, the cost effectiveness for a well where the associated gas contains 40 tpy methane is \$1,758 per ton of methane, which is also considered reasonable. Considering that routing associated gas to a flare or control device is an adequately demonstrated method and considering this cost effectiveness leads the EPA to conclude that BSER to reduce the methane emissions from associated gas from existing oil wells where the associated gas contains 40 tpy or less of methane is routing to a flare. This outcome is consistent with the recommendations made by the commenters.

Comment: One commenter⁴¹⁵ stated that repeated, onerous technical infeasibility analyses and detailed recordkeeping should be eliminated in the final rule for wells with low associated gas production.

Response: Because the EPA has determined that BSER for this subcategory of existing sources is routing to a flare or control device, the final model rule does not include a requirement to demonstrate technical infeasibility for wells with associated gas containing 40 tpy or less of methane. The presumptive standard allows sources in this subcategory to routinely flare without needing to make a demonstration of technical infeasibility. However, the final presumptive standard does include the requirement to calculate and document the methane content of associated gas using the GOR.

The calculation is based on a simplified version of the methodology in subpart W of the GHGRP.

Note that under the presumptive standard in the final EG, owners and operators of these low associated gas production wells are allowed to route the associated gas to a sales line, use it as onsite fuel or for another beneficial purpose, or inject/reinject it. In fact, the EPA encourages this option where possible. If a source elects to comply with one of these options, the presumptive standard would not require that source to comply with the requirement to calculate the annual methane content of the associated gas.

Comment: One commenter⁴¹⁶ stated that many older, existing well sites in the Midland Basin do not have flares onsite, and it would present a significant capital expense to add a flare or similar control device at each existing well site. Another commenter⁴¹⁷ stated that “for many conventional oil wells in Pennsylvania and New York, a gas sales line is not reasonably available. The “associated gas” produced at these conventional oil and gas well sites would not be sufficient to sustain a flare, much less justify the changes and capital expenditures needed to attempt to use the gas onsite. The commenter indicated that the EPA must expressly allow Pennsylvania and New York conventional oil producers to vent the small volumes of “associated gas,” which the commenters contend is the only safe and environmentally sound method of dealing with associated gas at some Pennsylvania conventional oil wells. The first commenter stated that the EPA should consider the remaining useful life of these existing sources, as required by the CAA.

Response: The EPA acknowledges these comments and understands that certain situations exist where the methane content in the associated gas is low and there is not a flare or control device onsite. The EPA also recognizes that the cost of installing a new flare or control device solely to reduce the methane emissions from the associated gas could be above what is typically considered reasonable by the EPA for wells with very low levels of methane. Both commenters cite instances where the wells are older and located in specific geographic locations. We conclude that these situations are most likely to occur for older wells where the wells are approaching the end of their useful lives. The EPA also believes that the wells discussed by comments do not represent the majority of designated

facilities across the country. Therefore, the EPA did not elect to further subcategorize wells with 40 tpy or less associated gas methane into those sites with and without existing control devices. First, the EPA believes that many of these sites likely have existing control devices already onsite that could accommodate the associated gas. The EPA is aware that several states, including New Mexico, North Dakota, and Texas, have regulations that require control devices in certain situations that are relevant here. Second, we believe that the particular sites discussed by commenters could be candidates for states to examine under the RULOF framework of 40 CFR part 60, subpart Ba, when states are developing their state plans in accordance with these final EG in 40 CFR part 60, subpart OOOOc. States can consider the RULOF-specific situations at the low associated gas production wells that do not have flares or other control devices onsite to possibly apply a standard of performance less stringent than the presumptive standard in this EG consistent with the EPA’s implementing regulations. Further, the EPA acknowledges that the Agency did not assess costs for existing wells that are located more than 5 miles away from a gathering system, and states may wish to examine the possibility of invoking RULOF for situations where a well with low levels of associated gas is located a far distance away from a gathering system and cannot otherwise comply with the alternatives included in the presumptive standard.

ii. BSER for the Subcategory of Wells With Associated Gas Containing Greater Than 40 tpy Methane

As discussed for new sources, routing associated gas to a sales line is an adequately demonstrated method for reducing methane emissions. As shown in table 23, the cost effectiveness of routing the gas to a sales line for wells with associated gas containing greater than 40 tpy methane is at levels considered reasonable by the EPA, especially in situations where the well is relatively near the gathering system. Therefore, the EPA determined that BSER for this subcategory is routing the associated gas to a sales line. As with new sources, the EPA believes that the other options that achieve the same level of emissions reduction should be allowed.

As discussed for modified and reconstructed sources, the EPA recognizes that existing sources were likely originally drilled without the expectation that the EPA would issue these EG which include a presumptive

⁴¹⁵ EPA-HQ-OAR-2021-0317-2403.

⁴¹⁶ EPA-HQ-OAR-2021-0317-2283.

⁴¹⁷ EPA-HQ-OAR-2021-0317-1341.

standard of routing the associated gas to a sales line, using it as onsite fuel or for another beneficial purpose, or injecting/reinjecting it. The location of these existing wells is established, and the owner or operator may not have the ability to move the well to allow a closer connection to a sales line, to inject into another well, or perhaps to utilize any other option. Therefore, the EPA concluded that it is appropriate to allow existing wells with greater than 40 tpy methane to routinely flare associated gas or route it to control with a technical infeasibility determination and certification which is renewed annually.

The final presumptive standards for existing wells with associated gas containing greater than 40 tpy methane are to reduce or eliminate emissions of methane by: (1) Recovering the associated gas from the separator and routing the recovered gas into a gas gathering flow line or collection system to a sales line, (2) recovering the associated gas from the separator and using the recovered gas as an onsite fuel source, (3) recovering the associated gas from the separator and using the recovered gas for another useful purpose that a purchased fuel or raw material would serve, or (4) recovering the associated gas from the separator and reinjecting the recovered gas into the well or injecting the recovered gas into another well. In addition, the final presumptive standards for this subcategory allow the associated gas to routinely be routed to a flare or control device that reduces methane and VOC emissions by at least 95.0 percent if annual demonstrations are made that it is technically infeasible to route the associated gas to a sales line, use it as onsite fuel or for another beneficial purpose, or inject/reinject it and the determination is certified by a professional engineer or another qualified individual with expertise in the uses of associated gas. See section XI.F.2.g of this document related to the infeasibility determination and certification.

Comment: One commenter⁴¹⁸ stated that the EPA failed to understand the implications of inherent production depletion on the economics and emissions from smaller wells. The commenter asserted that there are fundamental factors that are not adequately considered in the EPA assessments, and that, as oil and natural gas wells undergo their inherent depletion, the reduced volumes of production limit the amount of emissions that can be generated.

⁴¹⁸ EPA-HQ-OAR-2021-0317-2446.

Response: The EPA understands the depletion of production over time and understands that it impacts the associated gas volume, and thus the methane contained in the associated gas. Therefore, the presumptive standard included in the final EG includes the provision that existing wells whose production is less than 40 tpy of methane upon becoming a designated facility can flare routinely without a demonstration of technical infeasibility. The EPA determined that for wells with above 40 tpy of methane it is reasonable to route the gas to a sales line or choose an equivalent alternative, or in the absence of a feasible alternative, to flare the gas. While the level of gas production may decline over time from above 40 tpy to below, the EPA considers the cost of control of the gas from designation as a designated facility producing over 40 tpy to the time of well closure to be reasonable, and considers that the cost may be mitigated by any recovery from an associated gas management technique that allows some cost savings. Further, if an owner/operator is already complying with a zero-emissions option, then they should be able to continue to comply with that option cost-effectively, even if their production declines, as they have already made the investment.

f. Temporary Flaring/Venting

Comment: A number of comments were received on the topic of temporary flaring and venting. Commenters from across the spectrum (industry, state agencies, environmental organizations) agree that there are extenuating circumstances beyond the reasonable control of the operator that can result in the inability to exercise the primary use option. Further, there is agreement that flaring should be allowed in these circumstances. Commenters encouraged the EPA to distinguish between “routine” and “non-routine” flaring events.

In the December 2022 Supplemental Proposal, we proposed “to require that if owners and operators anticipate that there may be interruptions in the ability to route the associated gas to a sales line or to use it for another beneficial purpose, they must provide a technical or safety demonstration in their annual report and install and operate a control device that achieves the required reduction during these temporary periods” (p. 74780).

While there was agreement among the commenters on the need to allow temporary flaring, there was also universal objection to this proposed requirement for technical or safety

demonstrations to justify flaring. One commenter⁴¹⁹ urged the EPA to abandon the broad, unclear technical infeasibility exemption. Another⁴²⁰ recommended the replacement of the “technical infeasibility” exemption with clearly delineated circumstances for temporary flaring. Another⁴²¹ contended that, for those situations where the gas from the well is connected to a sales line and there are instances where the gas needs to be routed intermittently to a control device for equipment maintenance, repairs, emergencies, or other similar situations, this type of flaring should not have to undergo repeated, onerous infeasibility determinations and detailed recordkeeping requirements. Another commenter⁴²² requested that for wells where the operator has designed and configured the separator to recover and sell or beneficially use associated gas, the EPA remove the requirement to provide an infeasibility or safety justification for controlling associated gas when the primary means of disposition is temporarily unavailable. Another commenter⁴²³ explained that when a facility is designed with a certain configuration for handling the disposition of associated gas, it is unreasonable to expect facilities to design for multiple uses based on emerging technologies before they can resort to flaring, especially during these short, intermittent periods. They did not support making technical or safety demonstrations where disruptions or interruptions in the gas gathering infrastructure result in the need to route the associated gas to a control device for temporary periods. One commenter⁴²⁴ suggested that, rather than an infeasibility determination being required for every instance, a one-time infeasibility determination should suffice.

Commenters⁴²⁵ recommended that, rather than requiring an infeasibility demonstration for specific instances, the EPA delineate instances in the rule where temporary flaring is allowed. Commenters generally indicated that flaring should be allowed during upset conditions, which one commenter⁴²⁶ defined as emergency circumstances outside of the control of an operator that can interrupt its ability to comply with the standard. Commenters also provided

⁴¹⁹ EPA-HQ-OAR-2021-0317-2408.

⁴²⁰ EPA-HQ-OAR-2021-0317-2433.

⁴²¹ EPA-HQ-OAR-2021-0317-2403.

⁴²² EPA-HQ-OAR-2021-0317-2326.

⁴²³ EPA-HQ-OAR-2021-0317-2428.

⁴²⁴ EPA-HQ-OAR-2021-0317-2403.

⁴²⁵ EPA-HQ-OAR-2021-0317-2408 and -2433.

⁴²⁶ EPA-HQ-OAR-2021-0317-2433.

specific situations, including the following:

- Due to a temporary, unplanned loss of connection to, or ability to route gas to, a gathering system.
- During the commissioning of pipelines, equipment, or facilities.
- When the natural gas does not meet pipeline specifications.
- Temporary failure of equipment.
- During startup and shutdown activities.
- During maintenance activities.
- During construction activities and facility modifications.
- During well testing.

In addition to suggesting that the EPA delineate specific instances when temporary flaring is allowed, commenters recommended that the EPA establish clear time limitations during which the flaring is permitted.

In addition, one commenter⁴²⁷ identified circumstances where venting may be warranted. The commenter acknowledged that venting may be necessary for safety. In addition, they added that operators may need to vent for a very brief period during downhole monitoring activities, namely when monitoring the downhole pressure during bradenhead monitoring and packer leakage tests.

Commenters stressed that state rules, specifically in Colorado and New Mexico, allow operators to flare or vent gas for short periods of time during upset conditions or emergencies, including temporary unavailability of access to a gathering line. Further, both states list specific instances and time frames when flaring is allowed. Examples cited by the commenters include the following.

A commenter⁴²⁸ discussed circumstances where the EPA may consider exemptions from its capture requirements in which flaring is authorized. One circumstance that may give rise to an operator's need to flare on a temporary basis is the commissioning of pipelines, equipment, or facilities. The commenter provides that New Mexico allows operators to flare temporarily during these circumstances, and even then "only for as long as necessary to purge introduced impurities." An operator may need to flare temporarily when it is first connecting to a pipeline that has just been constructed if the pipeline was cleaned out with substances that the midstream operator does not want in the gas.

The commenters report that both Colorado and New Mexico allow

operators to vent or flare during bradenhead monitoring. Colorado limits bradenhead monitoring to 30 minutes. New Mexico also allows operators to flare or vent during packer leakage tests.

Commenters⁴²⁹ stated that New Mexico allows for temporary venting or flaring during an emergency. An emergency means "a temporary, infrequent, and unavoidable event in which the loss of natural gas is uncontrollable or necessary to avoid a risk of an immediate and substantial adverse impact on safety, public health, or the environment" other than in certain exceptions. One such exception is "venting or flaring of natural gas for more than 8 hours after notification that is caused by an emergency, an unscheduled maintenance, or a malfunction of a natural gas gathering system." In other words, an upstream operator may vent or flare during a temporary, infrequent, and unavoidable event involving loss of connection to a sales line provided the midstream operator notifies the producer of the disruption to the operator of the sales line. However, an upstream operator cannot vent longer than 8 hours in this circumstance.

One commenter⁴³⁰ provided that both Colorado and New Mexico allow operators to flare or vent gas for a short period of time during upset conditions or emergencies which include temporary unavailability of access to a gathering line. The commenter explained that the Colorado rules provide a concise, clear definition of upset condition combined with a limit on the amount of time an operator may flare or vent during such circumstances. Colorado allows operators to vent or flare for up to 24 cumulative hours during an upset condition while New Mexico allows operators to vent or flare for up to 8 hours during an emergency. Loss of a connection to a pipeline qualifies as an upset condition under the Colorado rules and an emergency under the New Mexico rules.

The commenter added that New Mexico allows for temporary venting or flaring during an emergency. An emergency means "a temporary, infrequent, and unavoidable event in which the loss of natural gas is uncontrollable or necessary to avoid a risk of an immediate and substantial adverse impact on safety, public health, or the environment" other than in certain exceptions.

Response: As discussed in section XI.F.2.b of this document, the representative well and the BSER

analysis are focused on associated gas emissions during routine operations. We appreciate the information and insights provided by the commenters, and overall we agree with the recommendations.

First, we recognize that there are circumstances that could arise that are beyond the control of the owner or operator and that could result in the temporary inability to comply with the standards, and we do not believe it is appropriate to require the shut-in of the well in such instances.

We agree with the commenters that the proposed requirement to demonstrate infeasibility based on technical or safety reasons for each of these temporary instances is not the most efficient solution. Rather, in the final rule, we have incorporated an approach similar to requirements adopted by New Mexico and Colorado. The final rule identifies specific circumstances in which temporary flaring or venting are allowed. The final rule also includes maximum timeframes for each circumstance. Following are the specifics included in the final rule. Temporary flaring (or routing to a control device to achieve 95 percent reduction) is allowed:

- For up to 24 hours during a deviation caused by a malfunction.
- For up to 72 hours during repair, maintenance including blowdowns, a packer leakage test, a production test, or commissioning.
- For up to 30 days during temporary interruption in service from the gathering or pipeline system.
- For up to 72 hours if associated gas does not meet pipeline specifications.

While temporary flaring or routing to a control device is allowed in these situations, it is important to ensure that, with the additional gas that is being routed to the flare or control device during this temporary period, the flare or control device continues to operate properly. Therefore, the final rule includes the requirement that the owner or operator demonstrate that applicable flare or control device requirements are being met during the temporary period when the associated gas is routed to the control.

Comment: One commenter⁴³¹ supported the use of temporary control devices for situations when the associated gas could not be routed to a sales line, used as onsite fuel or for another beneficial purpose, or injected/reinjected. The commenter explains that some sites may have permanent control devices for these scenarios. However, temporary controls can be used to

⁴²⁷ EPA-HQ-OAR-2021-0317-2433.

⁴²⁸ EPA-HQ-OAR-2021-0317-2433.

⁴²⁹ EPA-HQ-OAR-2021-0317-2433 and -2408.

⁴³⁰ EPA-HQ-OAR-2021-0317-2408.

⁴³¹ EPA-HQ-OAR-2021-0317-2218.

minimize emissions during planned maintenance, startup, and shutdown activities. Emissions from these temporary controls are permitted as an alternate operating scenario, as a part of normal operations. Another commenter supported flaring the gas by using a permanent or temporary control device that achieves 95 percent efficiency during periods of time when the associated gas is routed to the control device.

Response: In the December 2022 Supplemental Proposal, we stated that we anticipated that a control device used to reduce emissions during these temporary periods “would need to be permanently installed.” However, we specifically requested comment on whether the use of temporary controls could also serve this purpose. Commenters responded that such control devices would likely be permanent controls, albeit control systems that are present for reasons other than providing redundant control for associated gas.⁴³²

The EPA has determined that it is not necessary that a control device be permanently installed for these situations. However, if a temporary flare or control device is used, it is required to meet the same control device requirements as a permanent control device.

In addition to the allowance for temporary flaring or routing to a control device, the final rule allows venting in the following circumstances and durations:

- For up to 12 hours to protect the safety of personnel.
- For up to 30 minutes during bradenhead monitoring.
- For up to 30 minutes during a packer leakage test.

The final rule requires that detailed records be kept of each of these venting situations.

g. Infeasibility Demonstration and Certification

The proposed NSPS OOOOb regulation and EG OOOOc presumptive standards both included the allowance that associated gas could be routed to a flare or control device after a demonstration and certification that it is infeasible to route the associated gas to a sales line or to comply with the other options. The December 2022 Supplemental Proposal required that this demonstration include a detailed analysis documenting and certifying the technical or safety infeasibility for all options. It also listed specific types of other useful purposes that owners and

operators were required to address, specifically methane pyrolysis, compression of gas for transport to another facility, conversion of gas to liquid, and production of liquified natural gas. The proposal required that this demonstration be certified by a professional engineer or another qualified individual with expertise in the uses of associated gas.

As discussed in section XI.F.2.f of this document, there were many comments submitted that objected to the proposal to require a demonstration of infeasibility based on technical or safety reasons for temporary use of a flare or control device in instances when the primary option (e.g., routing the associated gas to a sales line, using it as onsite fuel or for another beneficial purpose, or injecting/reinjecting it) is unavailable. Rather they suggested that the rule and presumptive standards include specific instances when such temporary flaring or routing to control is allowed. As also discussed in section XI.F.2.f of this document, the final rule includes such a list of specific circumstances. Therefore, the infeasibility demonstration and certification provisions in the final rule are applicable to situations where routing the associated gas to a sales line, using it as onsite fuel or for another beneficial purpose, or injecting/reinjecting it are not feasible and routing to a flare or control device is routine.

On a related topic, one commenter⁴³³ suggested that safety concerns are by their nature temporary and would never give rise to the need to flare indefinitely. The commenter suggested that the EPA should therefore require that any safety-related flaring cease when the safety concern no longer exists. The EPA agrees that the need to flare or route to control for safety reasons is a temporary issue, and not a reason that would warrant long-term routine flaring. Therefore, the final rule allows routine flaring or routing to control based only on technical infeasibility, and not safety.

Comment: Commenters⁴³⁴ suggested that the EPA not require consideration of predetermined beneficial uses for oil well associated gas, and, if the EPA retains such a list, any included beneficial use must be commercially viable. One commenter stated that the EPA proposed that operators must certify that use of “recovered gas for another useful purpose that a purchased fuel or raw material would serve” is not feasible “due to technical or safety reasons” before the operator may

control associated gas onsite. They added that the EPA proposed that the feasibility analysis must include consideration of using gas for “methane pyrolysis, compressing the gas for transport to another facility, conversion of gas to liquid, and the production of liquified natural gas.” The commenter fully supports the beneficial use of natural gas where reasonably feasible and cost-effective and further supports development of additional technologies that would provide a broader range of potential beneficial uses. The commenter believed that the EPA’s inclusion of a predetermined list of uses suggests that the EPA has determined each of these beneficial uses to be technically feasible, commercially available, and appropriately included as part of the associated gas BSER. The commenter contends that the EPA, however, has provided no support for this apparent determination.

Accordingly, the commenter requested that the EPA remove this list of beneficial uses. Further, to the extent the EPA maintains such a list of beneficial uses, the commenter requested that the EPA remove any unproven “emerging technologies.” The commenter stated that CAA section 110(j) provides the appropriate pathway for sources to evaluate emerging technologies to meet NSPS. According to the commenter, requiring evaluation of unproven emerging technologies sidesteps both the BSER demonstration and the CAA section 110(j) process in violation of the CAA. Another commenter, a state agency,⁴³⁵ supported emerging technologies as potential methods for controlling emissions from oil and gas facilities and recommended that the rules allow the use of emerging technologies as a recognized method of achieving a beneficial use for associated gas. The commenter reported that some companies use the associated gas as fuel for electric generating units or compress the gas and send it to another site for processing. The commenter believed that useful purpose should include, but not be limited to, uses or purposes that a purchased fuel or raw material would serve. The commenter also believed that useful purpose should not be explicitly defined in the rule language, and that the owner or operator can provide a demonstration or certification that they meet this criterion. Due to the unpredictable nature of technological advancement, the commenter believed it would be shortsighted for the EPA to limit this aspect of the rule to only narrowly defined or specified processes or technologies. Certain technologies for

⁴³² EPA-HQ-OAR-2021-0317-2433.

⁴³⁴ EPA-HQ-OAR-2021-0317-2326 and -2218.

⁴³⁵ EPA-HQ-OAR-2021-0317-2218.

⁴³³ EPA-HQ-OAR-2021-0317-2326.

reducing methane and other GHG emissions, such as gas compression for offsite transport, can also result in collateral emissions of other regulated pollutants which are subject to the national ambient air quality standards (NAAQS).

Response: The EPA reviewed these comments and concluded that the regulation should not include a specific list of other beneficial uses, for the reasons pointed out by the commenters. However, as discussed in section X.F.2.a of this document, it is the responsibility of the owner and operator, along with the qualified professional engineer or other qualified personnel performing the evaluation, to conduct due diligence by ensuring that the list of options evaluated be comprehensive and address commercially viable solutions.

Comment: One commenter⁴³⁶ argued that the EPA must limit the exemption by clearly delineating specific “technical” reasons that would justify flaring in lieu of the four gas recovery options. They stated that the EPA must require operators to demonstrate the physical impossibility of each of the gas recovery options to claim the exemption to flare. The commenter provided potential physical impossibility demonstrations for each abatement method.

Response: The EPA believes that including specific criteria in the rule would be short-sighted and potentially eliminate legitimate reasons that an option is technically infeasible. As discussed in section X.F.2.a.1 of this document, the EPA generally characterizes acceptable reasons in the general categories of physically, logistically, or technically infeasible. Examples are provided in that section.

Comment: One commenter⁴³⁷ suggested that the BSER opt-out should include economic factors in addition to technical feasibility. The commenter reported that the EPA concedes that it is proposing multiple regulatory requirements whose implementation would be so burdensome that they would be “technically infeasible” for some set of affected facilities. According to the commenter, the EPA thus gives affected facilities the ability to “opt out” of the performance standard if the affected facility can show that compliance with the performance standard would be infeasible for technical or safety reasons. The commenter contends that “technically infeasible” is a misnomer and that the EPA should explicitly include economic factors in addition to a technical

feasibility analysis. The commenter stated that, instead of conflating technical feasibility and economic considerations, the EPA in its final rule should transparently state that economic factors must be part of an affected facility’s ability to opt out of the regulatory requirement. A state agency commenter⁴³⁸ asked what factors or thresholds should be considered if economic feasibility needs to be assessed.

Response: The EPA disagrees that economic feasibility is a valid criterion on which to allow routine flaring or routing to control as part of the standard. As shown in Table 23, the EPA has determined that the costs associated with the control option determined to be BSER (routing to a sales line) are reasonable. Put another way, the EPA has already considered costs when setting the standard. As such, there is no reason to allow for the type of “economic feasibility” showing that commenters are requesting. Further, to include economic feasibility as a criterion would necessarily take into account many aspects of plant operation that are not related to the cost of the control option (the BSER). The approach that commenters suggest could result in a situation where wells that are operating close to the margin due to inefficiencies and poor operation obtain an allowance to routinely flare while more efficiently operated wells do not. The EPA does not believe that allowing for this type of outcome is appropriate because it would unfairly provide preferential treatment to certain owners and operators based solely on the fact that their operation is less efficient. Lastly, allowing the type of economic feasibility that commenters are asking for would necessarily entail a certain degree of subjectivity that the EPA does not find to be appropriate in this context. The EPA believes that it would be inappropriate to establish such thresholds in this context and does not find it necessary.

Comment: One commenter⁴³⁹ points out that the EPA proposal contemplated four abatement alternatives to deal with associated gas from oil wells. While each alternative has its pros and cons, the alternatives are also necessarily based upon, to some extent, well and/or lease economics. The predominant methodology used by regulators, including the EPA, and operators, is to evaluate these economic decisions on the gas production only and its prevailing pricing. The commenter held that the entire well/lease revenue

stream—including revenue from oil—needed to be considered, especially if the decision to get to a sales line is the question. The commenter stated that considering gas revenue only actually promotes waste and negative environmental impact. Therefore, according to the commenter, the EPA rejects economic viability as a criterion to be considered in the infeasibility determination that would allow routine flaring.

Response: The EPA agrees with the premise of the comment that the standards for associated gas should not be limited to those options whose cost can be covered by the recovery of associated gas. The EPA’s BSER analysis acknowledges that cost recovery through the sale or use of associated gas will contribute to the cost effectiveness of some methods of reducing emissions from associated gas, but the EPA did not make the ability to recover the gas for sale the defining criteria to select BSER or the equivalent alternatives. For example, an operator who chooses to inject the gas into the well or another well may not derive any financial benefit to injecting the gas in the form of greater oil production, but injecting the gas is acceptable in lieu of routing to a sales line because it achieves emissions reductions equivalent to those for routing the associated gas to a sales line.

Comment: One commenter⁴⁴⁰ believed that the exemption for technical infeasibility presents enforcement challenges. While an operator’s demonstration of technical infeasibility must be signed and certified as to its truth, accuracy, and completeness, the commenter provided that there is no requirement that the EPA review and approve this demonstration prior to an operator’s flaring. Rather, the proposal only required that operators retain records of the certified demonstration and provide them to the EPA as part of annual reporting. The commenter indicated that this lack of requirement raises the possibility that flaring will occur in the absence of a full, accurate, complete, or otherwise adequate demonstration. The commenter indicated that in order for the EPA to identify any problems or shortcomings in the certified demonstration, the EPA must review the operator’s documentation, but this review will necessarily occur after an operator has flared, potentially for a considerable amount of time. The commenter states that this opens the door to extended periods of flaring in violation of the rules. Another

⁴³⁶ EPA-HQ-OAR-2021-0317-2433.

⁴³⁷ EPA-HQ-OAR-2021-0317-2326.

⁴³⁸ EPA-HQ-OAR-2021-0317-2247.

⁴³⁹ EPA-HQ-OAR-2021-0317-2433.

⁴⁴⁰ EPA-HQ-OAR-2021-0317-2433.

commenter⁴⁴¹ asserted that the technical infeasibility exemption places a significant compliance monitoring burden on the EPA, or on states with delegated air quality programs.

Response: The EPA does not agree with these commenters. As explained above, the final NSPS OOOOb and EG OOOOc include provisions that allow owners and operators to make certain technical infeasibility demonstrations in limited circumstances. To the extent that an owner or operator makes such a showing, the EPA believes that the requirement to submit the demonstration and certification of infeasibility in the annual report provides the opportunity for the EPA and/or state agency to conduct a review. In the event that the owner or operator submits an inadequate or fraudulent determination, or no determination at all when they should have, they could be subject to penalties. In addition, the professional engineer or other individual who certified the demonstration could be subject to penalties, including criminal charges. Therefore, no changes were made to the proposed requirements for submission of the demonstrations and certifications.

Comment: With respect to the certification process, one commenter⁴⁴² recommended that the EPA require certification by an independent third party. The commenter pointed out that the EPA proposed to allow certification by either a professional engineer or a “qualified individual with expertise in the uses of associated gas.” Notably, per the EPA’s proposal, an operator could use an in-house engineer or other qualified individual, such as a contractor. The commenter noted that there is no requirement that the individual be independent from the operator. Certification by an independent third party, rather than a professional engineer or a “qualified individual with expertise in the uses of associated gas,” either of whom could be an in-house individual or a person with significant ties to the company, will enhance the credibility and reliability of the report. Certification by an independent third party of all demonstrations seeking a flaring exception is necessary to ensure a robust, complete, and accurate demonstration of the reasons underlying the flaring request.

Response: The EPA does not agree that it is necessary for the certifier to be an independent third party. In many cases, a person most knowledgeable about the well characteristics and

specifics of the operation may be someone employed by the company. While the EPA understands the concern raised by the commenter about the certification being made entirely “in-house,” the EPA points out the severe penalties and repercussions that could occur for both the owner/operator and the certifier, as discussed here.

Comment: The commenter⁴⁴³ requested that the EPA further clarify that both the certifier and the owner/operator may be subject to penalties for submission of a fraudulent or significantly flawed certification. The commenter notes that this clarification is consistent with the EPA’s proposal for pneumatic pumps. The EPA proposed to include a technical infeasibility exemption from the zero-emissions pneumatic pump standard, provided an operator submits a demonstration certified by a qualified professional engineer or in-house engineer with relevant experience. The EPA notes that it “is committed to ensuring that this technical infeasibility provision is not abused or used as a loophole . . . ,” pointing to the potential for enforcement actions to be levied against both the owner/operator and the certifier upon submission of a “fraudulent, or significantly flawed” certification. The commenter urges the EPA to clarify that this same potential penalty is applicable to the submission of “fraudulent, or significantly flawed” certifications in the context of associated gas at the affected well facility, if the EPA retains the technical infeasibility exemption.

Response: The EPA agrees with the commenter. Flaws in a certified engineering analysis may result in an exception being inapplicable and a related enforceable violation of the standards. Fraudulent or significantly flawed certifications may result in both civil and criminal liability and penalties for the owner, operator, and the person that makes the certification.

Comment: One commenter⁴⁴⁴ suggested that operators seeking to routinely flare must submit a thorough analysis and engineering certification comparable to the initial certification each year. The commenter recommended that this demonstration include the same information as the initial demonstration, namely a detailed analysis documenting the technical infeasibility or safety reasons for the infeasibility and an explanation as to why none of the four gas recovery options are technically feasible or safe.

Each annual demonstration must be certified.

Response: The EPA agrees with this comment and has clarified that the exemption is only valid for a 1-year period and that a demonstration and certification must be conducted each year to continue to flare or route to control.

3. Gas Well Liquids Unloading Operations

In section X.F.3 of this document, the final NSPS OOOOb and EG OOOOc requirements for gas well liquids unloading operations are summarized. The BSER analysis is unchanged from what was presented in the November 2021 Proposal (see 86 FR 63211–14, section XII.D: Proposed Standards for Well Liquids Unloading Operations). Two regulatory approaches were proposed in the November 2021 Proposal. As discussed in the December 2022 Supplemental Proposal, the EPA considered the comments submitted and revised the proposed requirements. Details of these comments, the EPA’s responses, and the rationale for the supplemental proposal are provided in the December 2022 Supplemental Proposal **Federal Register** preamble. As discussed in section X.F.1 of this preamble, in the December 2022 Supplemental Proposal, the EPA proposed to define the “affected facility” as a single well. Further, the EPA proposed the “modification” definition to apply to a single well that undergoes hydraulic fracturing or refracturing. Significant comments were received on the December 2022 Supplemental Proposal on the following topics: (1) the EPA’s proposed zero-emissions standard, and (2) the EPA’s proposed recordkeeping and reporting requirements. For each of these topics, a summary of the proposed rule, the comments, the EPA responses, and changes made in the final rule (if applicable), are discussed as follows. These comments and the EPA’s responses to these comments would apply to the standards proposed in both the NSPS OOOOb and EG OOOOc because the same standards apply for both new and existing sources. The EPA’s full response to comments on the November 2021 Proposal and December 2022 Supplemental Proposal, including any comments not discussed in this preamble, can be found in the EPA’s RTC document for the final rule.⁴⁴⁵

⁴⁴⁵ *Standards of Performance for New, Reconstructed, and Modified Sources and Emissions Guidelines for Existing Sources: Oil and Natural Gas Sector Climate Review. Response to Public Comments on the November 2021 Proposed Rule and the December 2022 Supplemental*

⁴⁴¹ EPA–HQ–OAR–2021–0317–2428.

⁴⁴² EPA–HQ–OAR–2021–0317–2433.

⁴⁴³ EPA–HQ–OAR–2021–0317–2433.

⁴⁴⁴ EPA–HQ–OAR–2021–0317–2433.

a. Zero-Emissions Standard

In the December 2022 Supplemental Proposal, the EPA proposed regulatory text specifying that all gas well liquids unloading operations would be subject to the regulatory requirements. The BSER proposed was to employ techniques or technologies that eliminate methane and VOC emissions. Where meeting the zero-emissions standard is infeasible due to technical or safety reasons, the EPA proposed to require the employment of best management practices to minimize methane and VOC emissions during well liquids unloading operations to the extent possible.

The December 2022 Supplemental Proposal, however, specifically requested further comment and additional information on an alternative approach to applicability, where the standards for gas well liquids unloading would only apply to well liquids unloading operations that result in vented emissions.⁴⁴⁶

Comment: Several commenters⁴⁴⁷ opposed the EPA's proposed zero-emissions standard or asserted that the EPA should only regulate unloading operations that vent emissions.

Another commenter⁴⁴⁸ stated that the BSER must be technically feasible for the source category. The commenter provided a brief overview of the proposed standard under NSPS OOOOb that requires owners or operators to perform liquids unloading with zero methane or VOC emissions (86 FR 63179). The commenter mentioned that the proposed standard is based on a determination that non-emitting techniques constitute the BSER for these sources. At the same time, the commenter pointed out that the EPA acknowledged that non-emitting techniques are not always feasible or safe and that the EPA provides alternative standards to cover those situations.

In general, the commenter supported this approach as a practical matter and agreed that non-emitting measures and methods should be used where they are technically feasible and cost-effective. The commenter highlighted that the EPA rightly understands that non-emitting approaches are not always practicable and that imposing an absolute requirement would constitute an unwarranted prohibition on

necessary operations, such as liquids unloading, in many situations. With that in mind, the commenter believed that the proposed alternative best management practice measures are a common-sense solution.

Another commenter⁴⁴⁹ argued that the EPA should replace what the commenter believed was an infeasible zero-emissions standard with a requirement that the affected well liquids unloading operations minimize emissions through best management practices. The commenter stated that they have significant experience using a variety of practices to safely and effectively minimize the emissions associated with gas well liquids unloading but are concerned that those practices would not satisfy the EPA's proposed zero-emissions requirement. According to the commenter, there are many reasons why liquids may accumulate in a wellbore and require liquid unloading, some of which reasons are due to external factors not in the control of the well operator. The commenter stated that the proposed standard would necessitate a detailed review and discussion of infeasibility for each event with no benefit to emissions.

The commenter recommended that, rather than establishing the proposed zero-emissions standard with an exception for unloading with minimized emissions when zero-emissions unloading is technically infeasible, the EPA establish the use of best management practices to minimize methane and VOC emissions during liquids unloading events to the extent possible as the standard itself. The commenter warned that the program contemplated by the EPA sets an impossible compliance bar, and the commenter further reiterates that a standard to develop and use best management practices to minimize methane and VOC emissions during liquids unloading events to the extent possible will achieve the same emissions reductions while eliminating the unnecessary burdens associated with demonstrating that zero-emissions unloading is infeasible.

Another commenter⁴⁵⁰ asserted that the rule should only apply to venting during liquids unloading. The commenter added that industry innovated to address the environmental problem of venting during liquids unloading, and they believe that the EPA's proposal would disincentivize this innovation. The commenter explained that malfunctions of designed

zero-emissions liquids unloading events would be addressed with designed venting events, with required best management practices that minimize emissions, and with recordkeeping and reporting.

Similarly, another commenter⁴⁵¹ contended that the implementation of the rule would be easier if the standards only applied to wells that vent. However, the commenter suggested that the EPA only develop emissions requirements for facilities that vent emissions, not for facilities that would only vent emissions if something goes wrong or not as planned. In these situations, the commenter recommended the EPA develop separate requirements that would apply.

One commenter⁴⁵² requested that, with respect to the emissions standards for liquids unloading, the EPA revise the rule so that an unloading event which does not result in venting to the atmosphere is not an affected facility.

Conversely, another commenter⁴⁵³ supported the November 2021 Proposal to define affected facilities to cover all wells undergoing liquids unloading as a critical requirement to ensure that operators do not simply claim to conduct liquids unloading events with zero-emissions techniques, when venting is occurring. The commenter noted that the EPA has recognized, "under some circumstances venting could occur when a selected liquids unloading method that is designed to not vent to the atmosphere is not properly applied (e.g., a technology malfunction or operator error)."⁴⁵⁴ The commenter contended that in some cases, the malfunction or error could be so great that it results in venting 100 percent of the gas intended to be captured. Because of this possibility, the commenter argued, the EPA must require recordkeeping so it is aware of these events and overall emissions, and to build an understanding of what causes these errors and how they can be prevented. The commenter recommended that the EPA finalize the December 2022 Supplemental Proposal's option 1 and require operators of all wells undergoing liquids unloading to maintain records of the number of unloading events that occur, the method used, and any venting that occurred.

Response: The December 2022 Supplemental Proposal required that all liquids unloading events employ techniques or technologies that

Proposed Rule (6 FR 63110, November 15, 2021; 87 FR 74702, December 6, 2022).

⁴⁴⁶ 87 FR 74782.

⁴⁴⁷ EPA-HQ-OAR-2021-0317-0777, -0808, -2227, -2238, -2254, -2258, -2294, -2391, and -2446.

⁴⁴⁸ EPA-HQ-OAR-2021-0317-0808.

⁴⁴⁹ EPA-HQ-OAR-2021-0317-0777.

⁴⁵⁰ EPA-HQ-OAR-2021-0317-2227.

⁴⁵¹ EPA-HQ-OAR-2021-0317-2258.

⁴⁵² EPA-HQ-OAR-2021-0317-2238.

⁴⁵³ EPA-HQ-OAR-2021-0317-2433.

⁴⁵⁴ 86 FR 63179, November 15, 2021.

eliminate methane and VOC emissions (*i.e.*, a “zero-emissions standard”). If this was not feasible for safety or technical reasons, the EPA proposed to allow for the employment of best management practices to minimize venting of emissions to the extent possible. The EPA received comments that provided arguments against the proposed zero-emissions standard. These commenters generally emphasized that liquids unloading operations vary widely and standards should only apply to events that vent to the atmosphere. While we proposed a zero-emissions standard, we recognized that not every well that undergoes liquids unloading will be able to eliminate venting.

The EPA has determined that, because of the intermittent and necessary nature of allowing for variable methods and technologies employed to unload liquids, the inability to measure emissions during events, and the often-unpredictable timing as to when owners and operators may need to vent emissions, a work practice standard is more appropriate than an emissions standard for liquids unloading operations. When evaluating whether it is appropriate to establish an emissions standard, one of the things the EPA considers is whether the application of a measurement methodology is practical due to technological or economic limitations. While emissions can be measured from an unloading event, it may not be practical for many unloading events to be directly measured (*e.g.*, venting may not be anticipated or planned, type of technology employed to unload liquids does not lend itself to direct measurement of emissions). This is reflected in GHGRP subpart W required measurement and calculation methodologies. While in the August 2023 GHGRP subpart W proposal, the EPA proposed that emissions from liquids unloading under GHGRP subpart W must be calculated using direct measurements (calculation method 1) at least once every 3 consecutive years for each well, the proposal would continue to allow flexibility by allowing for the use of non-measurement calculation methods to accommodate times where direct measurement is not feasible or practical. For example, GHGRP subpart W calculation method 1 includes direct measurements, and methods 2 and 3 are non-measurement calculation methods. A very small percentage of events reported to the GHGRP (less than 3 percent for years 2015 to 2019) for

liquids unloading events were based on calculation method 1.⁴⁵⁵

The EPA also agrees that, by requiring that the proposed best management practices be implemented for liquids unloading events that vent, the same emissions reductions would be achieved, while eliminating the requirement for an owner or operator to have to document why it is infeasible to utilize a non-venting method due to technical, safety, or economic reasons. The EPA believes that best management practices can be implemented to safely and effectively minimize the emissions associated with gas well liquids unloading. However, with respect to commenters who believe that a well affected facility/designated facility that conducts gas well liquids unloading should only include liquids unloading events that vent, we disagree. As one of the commenters noted, and we agree, unintended/unplanned venting could occur from a malfunction or error and the EPA would want owners and operators to be required to follow best management practices and other reporting and recordkeeping requirements. Owners or operators can and should develop best management plans to minimize venting during liquids unloading, to include both planned/designated venting events and those venting events that occur that are unplanned.

To conclude, the EPA has maintained its proposal that each well affected facility that unloads liquids is subject to the requirement to employ techniques or technology(ies) that minimize or eliminate venting of emissions during liquids unloading events to the maximum extent. For unloading technologies or techniques that result in venting to the atmosphere, the final rule requires that owners or operators employ best management practices that meet minimum specified criteria to minimize venting of methane and VOC emissions for each gas well liquids unloading operation. Unloading events that employ non-venting liquids unloading technologies and techniques that do not result in venting of methane and VOC emissions to the atmosphere are not subject to best management plan requirements and the associated recordkeeping and reporting requirements under the rule. An owner or operator of a well affected facility that employs non-venting liquids unloading technologies and techniques is only required to comply with minimal recordkeeping and reporting

requirements. In instances where there may be an unplanned venting event, that event would be subject to the best management practices to minimize venting of emissions and the associated recordkeeping and reporting requirements. The EPA believes that the final work practice standard and associated recordkeeping and reporting requirements will incentivize owners or operators of well affected facilities and well designated facilities to minimize or eliminate the venting of emissions to the extent possible during liquids unloading events.

b. Recordkeeping and Reporting Requirements

In the December 2022 Supplemental Proposal, the EPA proposed specific recordkeeping and reporting requirements related to well liquids unloading operations. Wells that utilized a non-venting method would have been required to maintain records of the number of well liquids unloading operations that occur within the reporting period and the method(s) used for each well liquids unloading operation. A summary of this information would also have been required to be reported in the annual report. In recognition that under some circumstances, venting could occur when a selected liquids unloading method that is designed to not vent to the atmosphere is not properly applied (*e.g.*, a technology malfunction or operator error), under the proposed rule, owners and operators in this situation would have been required to record and report these instances, as well as document and report the length of venting and what actions were taken to minimize venting to the extent possible. Additionally, for wells that utilize methods that vent to the atmosphere, the proposed rule would have required: (1) Documentation explaining why it is infeasible to utilize a non-venting method due to technical, safety, or economic reasons; (2) development of best management practices that ensure that emissions during liquids unloading are minimized; (3) employment of the best management practices during each well liquids unloading operation and maintenance of records demonstrating that the best management practices were followed; and (4) reporting in the annual report both the number of well liquids unloading operations and any instances where the well liquids unloading operations did not follow the best management practices.

⁴⁵⁵ 2023 Final Rule-Liquids Unloading GHGRP Basic Analysis.xlsx. [See 2023 Final Rule TSD Supporting Spreadsheet Attachments.]

Comment: Several commenters⁴⁵⁶ requested that the EPA not require recordkeeping and reporting of non-venting liquids unloading events. One commenter⁴⁵⁷ suggested that operators conducting liquids unloading operations with zero methane and VOC emissions should not be subject to burdensome recordkeeping, reporting, and other requirements. One of the commenters⁴⁵⁸ noted that the non-vented liquids unloading reporting requirements are not feasible due to the nature of those events and because of the administrative burden associated with the reporting requirements with no net gain in emissions reductions. Similarly, one commenter⁴⁵⁹ requested that the EPA remove reporting requirements that do not provide valuable emissions-related information.

Another one of the commenters⁴⁶⁰ opposed the proposed recordkeeping and reporting obligations on owners or operators, on the grounds that they would be burdensome and yield no environmental benefit for well unloading activities that do not vent. For example, they noted, owners or operators of well affected facilities where gas well liquids unloading occurs must submit annual reports: (1) identifying the well affected facility; (2) disclosing the number of gas well liquid unloading operations that occurred there during the reporting period; (3) describing the unloading operation method used each time; and (4) reporting any deviations in detail along with corrective actions. See, *e.g.*, proposed 40 CFR 60.5410b(b) and 60.5415b(b). The commenter stated that when unloading operations do not result in any vented emissions, these reports serve no purpose. To avoid this result, the commenter recommended that the EPA clarify that the standards for gas well liquids unloading operations apply only to those operations that result in emissions to the atmosphere. The commenter stated that this action would appropriately limit the recordkeeping and reporting obligations and would still allow the EPA to gather compliance information for a well that vents to the atmosphere during liquid unloading. The commenter added that the EPA should also make similar changes to proposed 40 CFR 60.5390c in EG OOOOc.

One commenter⁴⁶¹ recommended that proposed recordkeeping and reporting for liquids unloading operations be simplified into a manageable framework for operators and streamlined for liquid unloading operations that vent to the atmosphere. The commenter noted that the information proposed by the EPA within 40 CFR 60.5420b and 40 CFR 60.5420c for the recordkeeping and reporting as it pertains to liquid unloading operations is focused more on an operator's tracking and certifying techniques and less on allowing an operator to perform the necessary procedures to unload liquids accumulated within the wellbore and maintain natural gas production with as minimal emissions as possible. To address this shortcoming, the commenter suggested that the EPA define the data that operators should track per unloading operation and remove all superfluous records that generate additional burden for the operator and the EPA without added environmental benefit. The commenter provided that these suggestions assume that liquid unloading operations are to be conducted using a work practice standard.

Furthermore, the commenter contended that the current proposed recordkeeping requirements do not offer a reasonable framework for operators to maintain compliance assurance. In fact, the commenter stated, the EPA has included a certification by a professional engineer for every instance a well unloading operation vents emissions to the atmosphere, in 40 CFR 60.5420b(c)(2)(ii)(B) and 40 CFR 60.5420b(b)(3)(ii)(B), based on the proposed zero-emissions standard. The commenter noted that an owner or operator may not know about gas well liquids unloading events that result in venting of emissions to the atmosphere until the liquid operation is taking place, based on a variety of parameters. For context, the commenter stated that a single well affected facility may undergo multiple liquid unloading operations in a single compliance period. For example, one well may necessitate an unloading schedule of four times in a year. Based on best management procedures, three of these events may occur with zero emissions, while one of the events might vent to atmosphere for a short duration using the same technique. The commenter believed the justification provisions in 40 CFR 60.5420b(c)(2)(ii)(B) to be untenable when the same technique used on a well may result in zero

emissions during some liquid operations but not during all liquid unloading operations in the same compliance period. The commenter asserted that the fact is that in some instances a well liquid unloading operation may need to vent emissions for a short duration, sometimes as little as 30 minutes, to safely perform the liquid unloading operation. The commenter therefore requested that the EPA:

1. Remove the additional engineering certification statements under the guise of technical demonstrations. These additional certifications would be unnecessary if the standard followed a work practice procedure.

2. Limit recordkeeping and reporting to liquid unloading operations that result in emissions. This would reduce the administrative burden for thousands of liquid unloading operation events. This is also consistent with how both Colorado and New Mexico have organized recordkeeping and reporting for their state regulations.

Similarly, another commenter⁴⁶² requested that the recordkeeping and reporting requirements be amended to be a workable framework for operators to assure compliance, including removal of the certification statement by an engineer in every instance that venting may occur.

Another commenter⁴⁶³ similarly argued that the EPA should not require recordkeeping or reporting for each well liquid unloading operation conducted during the year unless the EPA has defined "well liquid unloading operation" to mean only those well liquid unloading operations intended to vent to the atmosphere. As the EPA recognized in its supporting documentation, the commenter reports that one primary methodology that may be used to reduce or eliminate venting from removal of liquids of gas wells is a plunger lift. In most operational scenarios, a plunger lift will assist with liquid removal from the wellbore without any venting to the atmosphere. The plunger lift will operate either on a set cycle or based upon pressures reflected in the wellbore. However, not all plunger lifts are designed to have the necessary equipment onsite to track each cycle of the plunger lift. Thus, the commenter explains, the EPA's proposal could require installation of equipment to track the plunger cycles while providing no emissions reductions benefits. The commenter noted that the EPA has not fully evaluated the cost of installing and operating such tracking

⁴⁵⁶ EPA-HQ-OAR-2021-0317-0599, -0749, -2227, -2238, -2294, -2326, -2391, and -2428.

⁴⁵⁷ EPA-HQ-OAR-2021-0317-2227.

⁴⁵⁸ EPA-HQ-OAR-2021-0317-0749.

⁴⁵⁹ EPA-HQ-OAR-2021-0317-2258.

⁴⁶⁰ EPA-HQ-OAR-2021-0317-2391.

⁴⁶¹ EPA-HQ-OAR-2021-0317-2428.

⁴⁶² EPA-HQ-OAR-2021-0317-2248.

⁴⁶³ EPA-HQ-OAR-2021-0317-2326.

equipment in the BSER analysis, and given that there will be no emissions benefits, the EPA cannot show that such a requirement would be cost-effective. The commenter added that even where equipment is available to track the number of wellbore liquids removal events that do not vent to the atmosphere, the operational costs of undertaking that tracking are considerable and the data collected would be significant. According to the commenter, the EPA has provided no reasonable explanation for its need to obtain and track data relating to the number of wellbore liquids removal events that do not vent to the atmosphere. The commenter also stated that the EPA provides virtually no explanation for its decision to stick with option 1, other than the fact that “malfunctions” can result in vented emissions from liquids removal operations that would otherwise meet the zero-emissions standard. The commenter added that the EPA has no basis for concern with respect to malfunctions as it has implemented a robust AVO and OGI inspection program that would be expected to identify wells that have emissions during liquids removal that were not expected or intended.

The commenter concluded that one simple solution to this problem is to define well liquids unloading to mean only those wellbore liquids removal events that are intended to vent to atmosphere. By defining well liquids unloading in such a manner, the commenter believed, the EPA would encourage operators to find solutions that eliminate venting and to ensure that operators not only implement certain emissions reduction requirements to reduce venting to atmosphere but also record and report on those instances that do result in venting to the atmosphere.

One commenter⁴⁶⁴ cited from the EPA-referenced study by Dr. Allen, University of Texas, Environmental Science & Technology, December 9, 2014, *Methane Emissions from Process Equipment at Natural Gas Production Sites in the United States: Liquids Unloadings*, “Some wells with plunger lifts are automatically triggered and unload thousands of times per year.” The commenter stated that just a single well with thousands of unloading events per year would create a significant reporting burden, and when wells do not vent, they argued, this reporting should not be required.

Response: The EPA considered the commenters’ concerns and examples

provided regarding the burden associated with the proposed liquids unloading operations recordkeeping and reporting requirements. These concerns were evaluated along with the comments received on the zero-emissions standard. The EPA agrees that requiring an owner or operator to comply with some of the proposed recordkeeping and reporting requirements in instances where an unloading event does not result in venting to the atmosphere would impose a burden without any added benefit environmentally (e.g., requiring that the number of liquids unloading events that occurred when implementing a non-venting liquids unloading technology or technique be tracked and reported).

As discussed under section X.F.3.a of this document, the EPA has determined that the intermittent and necessary nature of the variable methods and technologies employed to unload liquids, the inability to reliably measure emissions, and the unpredictable nature as to when it may be necessary to vent emissions makes a work practice standard more practical and appropriate for liquids unloading operations than a zero-emissions standard. As a result of this determination, the final rule requires owners or operators of an affected gas well facility that unloads liquids to employ techniques or technology(ies) that minimize or eliminate venting of emissions during gas well liquids unloading events to the maximum extent. For unloading events that result in venting to the atmosphere, the final rule requires owners or operators of well affected facilities/well designated facilities employ best management practices to minimize venting of methane and VOC emissions for each gas well liquids unloading operation, in addition to having to comply with the associated recordkeeping and reporting requirements. Where liquids unloading events were conducted using a technology/technique that eliminates venting to the atmosphere, the final rule only requires owners and operators to report the identification of the well along with the non-venting technology or technique used in their annual report. Where unplanned venting occurs from these wells during a compliance period, an owner or operator would be required to follow their best management practices plan for such events and comply with the associated recordkeeping and reporting requirements for those events.

As a work practice standard, the engineering certification statement that would be required under the December

2022 Supplemental Proposal, which would have required an explanation of why it is infeasible to utilize a non-venting method due to technical, safety, or economic reasons, is unnecessary and has been removed from the final rule. Additionally, because there is no longer a requirement to comply with a zero-emissions standard, there is no longer a need to maintain records or reports containing information on a change of compliance method from a zero-emissions standard to the implementation of best management practices and vice versa.

4. Well Completions

In the November 2021 Proposal, the EPA proposed to retain the requirements found in NSPS OOOO and NSPS OOOOa for reducing methane and VOC emissions through REC and completion combustion. The BSER analysis is unchanged from what was presented in the November 2021 Proposal (see 86 FR 63234–36, section XII.I: Proposed Standards for Well Completions). The proposed regulatory text included in the December 2022 Supplemental Proposal was similar to the regulatory text found in 40 CFR 60.5375a for NSPS OOOOa. While the regulatory text was similar, the EPA was made aware of potential confusion related to the well completion requirements and well completion recordkeeping requirements for wildcat wells, delineation wells, and low-pressure wells. Therefore, the proposed regulatory text for NSPS OOOOb included language to clarify these particular standards for new, modified, and reconstructed sources moving forward. First, the EPA proposed regulatory text at 40 CFR 60.5375b(f) to clearly state the requirement to route emissions from wildcat well, delineation well, and low-pressure well completions to a completion combustion device in any instance (unless combustion creates a fire or safety hazard or can damage tundra, permafrost, or waterways). The EPA was also made aware from implementation of NSPS OOOOa that owners and operators were unclear as to whether they can choose to comply with 40 CFR 60.5375a(f)(3)(ii) and make a claim of technical infeasibility for the separator to function, which then precludes the requirement to route recovered emissions to a completion combustion device. The EPA noted in the December 2022 Supplemental Proposal that this preclusion was not the EPA’s intent in NSPS OOOOa and for this reason, we proposed to clearly specify at 40 CFR 60.5375b(f) that an alternative to routing to a separator (instead of routing all

⁴⁶⁴ EPA–HQ–OAR–2021–0317–2446.

flowback to a completion combustion device) is available only when the owner or operator is able to operate a separator and has the separator onsite (or otherwise available for use) and ready for use to comply with the alternative during the entirety of the flowback period. Second, the EPA proposed to eliminate recordkeeping requirements which are not necessary for wildcat wells, delineation wells, and low-pressure wells that had previously been included in NSPS OOOOa.

Specifically, the EPA proposed to not require records for “beneficial” use of recovered gas (*i.e.*, routed to the gas flow line or collection system, reinjected into the well or another well, used as an onsite fuel source, or used for another useful purpose that a purchased fuel or raw material would serve) nor records of “specific reasons for venting in lieu of capture.” These records were not required for wildcat wells, delineation wells, and low-pressure wells because the well completion standards at 40 CFR 60.5375b(f) require that all flowback, or gas recovered from flowback through the operation of a separator, be routed to a completion combustion device (*i.e.*, there will not be an instance, when complying with 40 CFR 60.5375b(f), that beneficial use of recovered gas will occur).

The EPA did not receive comments on the EPA’s well completion proposed requirements that would lead the EPA to change what was proposed in the December 2022 Supplemental Proposal and the EPA has finalized the well completion requirements as proposed for both the NSPS OOOOb and EG OOOOc.

G. Centrifugal Compressors

In section X.G of this document, the final NSPS OOOOb and EG OOOOc requirements for centrifugal compressors are summarized. The BSER analysis for wet seal centrifugal compressors is unchanged from what was presented in the December 2022 Supplemental Proposal (see 87 FR 74784–85, section IV.G: Centrifugal Compressors). However, detailed comments were received on the December 2022 Supplemental Proposal on the following topics: (1) redefining the affected facility to include compressors with dry seals and the proposed standard, (2) the EPA’s proposal to base the standard of performance as a numeric standard for self-contained wet seal compressors and centrifugal compressors equipped with dry seals, (3) the need to clarify that the standard is on a per-seal basis, (4) other inherently low-emitting compressor configurations, (5) the EPA’s extension

of requirements to centrifugal compressors located at centralized production facilities, and (6) wet seal compressors equipped with a seal oil gas separation system utilized on the Alaska North Slope (ANS). For each of these topics, a summary of the proposed rule (where relevant), the comments, the EPA responses, and changes made in the final rule (if applicable), are discussed here. These comments and the EPA’s responses to these comments generally apply to the standards proposed in both the NSPS OOOOb and EG OOOOc. The instances where the comment and/or response only applies to the NSPS OOOOb or EG OOOOc are noted. The EPA’s full response to comments on the November 2021 Proposal and December 2022 Supplemental Proposal, including any comments not discussed in this preamble, can be found in the EPA’s RTC document for the final rule.⁴⁶⁵

1. Redefining the Affected Facility To Include Centrifugal Compressors With Dry Seals and the Proposed Standard

In the December 2022 Supplemental Proposal, the EPA redefined the affected facility to include compressors with dry seals and proposed a dry seal volumetric flow rate of 3 scfm (per seal) as a numeric emissions standard.

Comment: Several commenters⁴⁶⁶ stated that the EPA should not adopt the proposed dry seal standard of 3 scfm (per seal) because that standard is unsupported and not adequately justified. Specifically, two commenters⁴⁶⁷ stated that the EPA must first obtain data—both on cost and, more importantly, on feasibility and reasonableness of the standard itself—to support a proper BSER analysis.⁴⁶⁸ Any other approach, according to the commenters, would be arbitrary and capricious. The commenters described three main concerns (with support for each of their concerns detailed in the RTC document for this action) with the

⁴⁶⁵ *Standards of Performance for New, Reconstructed, and Modified Sources and Emissions Guidelines for Existing Sources: Oil and Natural Gas Sector Climate Review. Response to Public Comments on the November 2021 Proposed Rule and the December 2022 Supplemental Proposed Rule* (86 FR 63110, November 15, 2021; 87 FR 74702, December 6, 2022).

⁴⁶⁶ EPA–HQ–OAR–2021–0317–2282, –2366, –2399, –2428, and –2483.

⁴⁶⁷ EPA–HQ–OAR–2021–0317–2282 and –2483.

⁴⁶⁸ For example, the commenters noted that the EPA has recently proposed to require measurements for dry seal compressors under the GHGRP, proposed “Revisions and Confidentiality Determinations for Data Elements Under the Greenhouse Gas Reporting Rule,” 87 FR 36920, 36974 (June 21, 2022). If the EPA finalizes that requirement, it will start collecting data for dry seal emissions.

BSER determination. These concerns included the following:

(1) The commenters stated that the BSER determination contains insufficient data to support the proposed standard or the cost that would be required to maintain it. The commenters specifically dispute the appropriateness of reliance on section 95668(d)(4–9), California’s Regulations⁴⁶⁹ for Greenhouse Gas Emission Standards for Crude Oil and Natural Gas Facilities, to support the standard. Research into the underlying sources of the California Air Resources Board (CARB) regulation does not yield supporting information for the development of the 3 scfm standard. According to the commenters, there is no data in the California rulemaking supporting any numeric standard for dry seals, much less a specific rate of 3 scfm.

(2) The commenters stated that the BSER determination does not consider data showing that seal emissions rate is a function of compressor size and suction pressure, and consequently, the standard does not properly account for compressor size; and

(3) The commenters stated that record is devoid of any information (or data) indicating that proper maintenance and repair could reduce such compressors’ dry seal emissions rate to 3 scfm or less, or any information regarding the associated costs of doing so.

Several commenters⁴⁷⁰ emphasized that more reliable information and data are or will be available that could be used in developing a dry seal emissions standard. One of the commenters stated that based on data submitted to the EPA pursuant to GHGRP subpart W for the 2021 calendar year, dry seal compressor driver power output ranged between 5 and 42,000 horsepower and for wet seals the compressor driver power output ranged between 40 and 53,665 horsepower.⁴⁷¹ The commenter expressed that it does not believe compressors associated with the higher end of this range should be expected to operate the same as compressors closer to the lower end of this range.

Several commenters⁴⁷² stated that, for transmission and storage, the majority of turbines are manufactured by Solar Turbines. The commenters suggested

⁴⁶⁹ <https://ww2.arb.ca.gov/sites/default/files/2020-03/2017FinalRegOrdersGHGEmissionStandards.pdf>.

⁴⁷⁰ EPA–HQ–OAR–2021–0317–2282, –2366, –2428, and –2483.

⁴⁷¹ Information was extracted from the EPA’s Envirofacts database using the GHG query builder: <https://enviro.epa.gov/query-builder/ghg>.

⁴⁷² EPA–HQ–OAR–2021–0317–2282, –2366, and –2483.

that the Solar Turbine Product Information Letter (PIL) ⁴⁷³ be considered as a superior reference compared to the Natural Gas STAR document. Information available from Solar shows that dry seal emissions rates are a function of compressor type (*e.g.*, size) and operating (suction) pressure. The commenters reported that the PIL provides data plots for a range of compressor sizes and suction pressures. The commenters stated that the PIL data plots clearly indicate that 3 scfm will be exceeded during standard operations for many units and/or at many suction pressures that are common on transmission systems. Since that data shows higher emissions rates for many applications, the commenters contended that it alone refutes the basis of the EPA's proposed 3 scfm emissions rate. According to the commenters, if the EPA insists on proceeding with a standard for dry seal compressors at this time, the EPA should establish a standard based on function/operating conditions for the seal (*i.e.*, unit size and suction pressure); or, if the standard is a single emissions rate, it must be high enough to address the largest units and highest suction pressures in natural gas operations.

As a result of these concerns, some commenters provided recommendations to the EPA for development of a dry seal emissions standard:

- One commenter ⁴⁷⁴ stated that the EPA should supplement the docket with information to support why the proposed value is representative of the population of dry seal compressors across the nation (taking into consideration compressor size variability).

- Several commenters ⁴⁷⁵ recommended that the EPA postpone establishing any type of quantitative threshold for dry seal centrifugal compressors until after it finalizes amendments to GHGRP subpart W. See 87 FR 36920 (June 21, 2022) (proposed rule). Once those amendments are implemented, the commenters contended, the EPA would have thousands of data points to give a more accurate dry seal centrifugal compressor measurements that can be used for a subsequent emissions threshold.

⁴⁷³ Solar Turbines Product Information Letter (PIL) 251, "Emissions from Centrifugal Compressor Gas Seal Systems," January 2013 (Attachment C of their Comments). [Attachment C was redacted in full in Docket.]

⁴⁷⁴ EPA-HQ-OAR-2021-0317-2428.

⁴⁷⁵ EPA-HQ-OAR-2021-0317-2282, -2305, -2399, and -2428.

- Several commenters ⁴⁷⁶ stated that if the EPA decides to re-propose a numeric emissions standard for dry seal compressors, it must first identify reliable information about emissions rates that are achieved by well-maintained dry seal compressors and the maintenance/replacement activity needed to achieve them. Because of the functional dependence on unit size and suction pressure, they contended, it is likely that a single emissions rate is not sufficient, unless that rate is high enough to address the largest units and highest suction pressures in natural gas operations.⁴⁷⁷ Second, they suggested that any emissions rate standard must be expressed as a per-seal standard.⁴⁷⁸ Finally, they stated that, if the standard would require yearly measurements and monitoring of these compressors for the first time, as the current proposal does, the cost of monitoring ⁴⁷⁹ would be part of the proposed standard and should be accounted for in the BSER analysis.

One commenter ⁴⁸⁰ noted that, in principle, they do not object to a standard for dry seal compressors. However, they suggested that the EPA should: (1) recognize that 3 scfm is an approximate average rate for some dry seal compressors, but it is not characteristic of units that may have an emissions rate several times higher—*e.g.*, large compressors with relatively high suction pressure; (2) consider the upper end range or tiered emissions rates in the standard; (3) conduct analysis and consider cost effectiveness of installing a seal vent recovery/control system if the emissions rate cannot be met; (4) account for the cost of additional monitoring that a numeric standard would require; (5) clarify that the selected standard applies for each dry seal, not for the entire compressor; and (6) if a standard is retained (considering the factors above), propose

⁴⁷⁶ EPA-HQ-OAR-2021-0317-2282, -2399, and -2428.

⁴⁷⁷ One of the commenters expressed that they also believed the EPA should investigate whether the types of onboard sensors that Solar Turbines provides with some of its models are prevalent in the industry. If that is the case, these sensors—even if they do not measure emission rates specifically—may be adequate to provide information about the health of the dry seals, possibly supporting a standard requiring seal replacement as recommended by the manufacturer.

⁴⁷⁸ The source information cited by the EPA (the California regulation and EPA Natural Gas STAR document) clearly indicates that this is an emission rate per seal, as does the Solar Turbines PIL. If a dry seal emission rate threshold is retained in the final rule, the commenters stated, it should be clearly indicated that the rate applies on a per-seal basis.

⁴⁷⁹ For example, a flow meter is estimated to cost upwards of \$10,000 and installation also costs upwards of \$10,000.

⁴⁸⁰ EPA-HQ-OAR-2021-0317-2366.

a work practice standard and define the schedule for operators to resolve the issue when a unit exceeds its defined emissions rate threshold.

While several of the commenters ⁴⁸¹ specifically recommended that the EPA wait for more accurate data based on GHGRP subpart W, they added that, if the EPA is intent on establishing a dry seal emissions threshold before receiving the GHGRP subpart W reports, they recommended relying upon the manufacturer's specified maximum leak rate for a particular unit. The commenters noted that a recent review of dry seal leak curves from a major supplier of centrifugal compressors to the natural gas industry indicates that dry seal leakage rates can vary from 2 to 20 scfm per compressor (with two seals per compressor), depending on the make, model, and operating suction pressure of the compressor. If the EPA wishes to set one threshold applicable to all dry seal centrifugal compressors in this rulemaking, the commenters recommended that the EPA set the threshold at 10 scfm per primary dry seal to allow for sufficient variability among existing dry seal leak rates.

Response: The EPA has evaluated these comments and acknowledges that the data available on dry seal compressor emissions and flow rates was limited and that a 3 scfm volumetric flow rate performance standard may not be achievable for some centrifugal compressors equipped with dry seals, even when properly maintained and the dry seal is not in need of repair. Prior to receipt of these comments and based on available information and data, it was believed that these higher-emitting dry seal compressors represented compressors in need of repair or maintenance. In fact, the EPA had not previously regulated centrifugal compressors equipped with dry seals because they were considered low-emitting when compared with compressors equipped with wet seals. What has become evident, however, is that some centrifugal compressors equipped with dry seals emit more than previously believed and that a properly functioning compressor equipped with a dry seal can be higher-emitting than a centrifugal compressor equipped with a wet seal that is subject to requirements under NSPS OOOOb.

Given that compressors equipped with wet seals are regulated under NSPS OOOO, NSPS OOOOa, and the final NSPS OOOOb, and given that compressors equipped with dry seals are known to emit more than some

⁴⁸¹ EPA-HQ-OAR-2021-0317-2282, -2305, -2399, and -2428.

compressors with wet seals, the final rule retains the requirement to conduct volumetric flow rate monitoring and associated maintenance and repair (as needed) of these compressors consistent with what is required for centrifugal compressors equipped with wet seals. However, the EPA has revised the proposed volumetric flow rate performance standard for centrifugal compressors with dry seals to be 10 scfm/seal (*i.e.*, representing a maximum flow rate applicable to all dry seals). Based on manufacturer data provided on dry seal rate curves for differing compressor models and configurations, a 10 scfm per seal flow rate performance standard is supported as a maximum flow rate performance standard that could be applicable to all dry seals until additional flow rate and emissions data are obtained under GHGRP subpart W.

The 10 scfm per seal flow rate performance limit reflects ordinary performance of a well-maintained unit, therefore minimal additional costs are expected. In many instances, compressors equipped with dry seals will already be required to conduct annual compressor vent volumetric flow rate monitoring under GHGRP subpart W. Owners or operators of these compressors will be subject to minor recordkeeping and reporting requirements, and maintenance and repair requirements would only apply where the volumetric flow rate performance standard of 10 scfm per seal is exceeded. For owners or operators not already required to conduct annual compressor vent volumetric flow rate monitoring under GHGRP subpart W, the only additional cost is the cost of conducting the required volumetric flow rate monitoring. See discussion in section XI.G.2 of this document on the EPA's decision to establish centrifugal compressor flow rate performance standards as work practice standards and not as numeric limits where an exceedance would be considered a violation.

As commenters noted, the EPA has requested flow rate/emissions information under GHGRP subpart W for compressors equipped with dry seals. Based on information received, the EPA may revisit and revise the 10 scfm per seal volumetric flow rate performance standard for compressors equipped with dry seals in the future.

2. Numeric Standard Versus Work Practice Standard

In reviewing the BSER determination and standards for centrifugal compressors proposed in November 2021, the EPA stated that it is feasible

to prescribe a standard of performance, rather than a work practice standard, for centrifugal compressors complying with the NSPS OOOOb self-contained wet seal centrifugal compressor and EG OOOOc wet seal compressor volumetric flow rate performance standards. The BSER was therefore proposed to conduct repair and maintenance activities to maintain emissions at or below a specified flow rate. Based on this rationale, the EPA proposed a numeric emissions limit requirement. The major difference between the numeric emissions limit standard proposed under the December 2022 Supplemental Proposal and what the EPA proposed in November 2021 was that under the December 2022 Supplemental Proposal, owners and operators would be required to maintain emissions at or below the specified emissions limit (a measured emissions flow rate) whereas under the November 2021 Proposal, owners or operators would have been required to conduct repairs and maintenance after discovering an exceedance of a flow rate of the specified numeric emissions limit (a measured emissions flow rate).

Comment: Several commenters⁴⁸² asserted that the rule should clarify the required compliance obligations, include a repair or replacement timeline, and eliminate avoidable emissions from repair to wet and dry seals. According to the commenters, the proposed NSPS rule was drafted to require an emissions flow rate limit for wet and dry seals. If the individual seal exceeds the 3 scfm (or a group of seals exceeds the applicable standard), the EPA expects the operator to repair or replace that seal, as appropriate.⁴⁸³ The proposed rule did not describe what is required if the measurement at the seal vent exceeds the applicable flow rate. The commenters recommend that dry seal centrifugal compressors and self-contained wet seal compressors be regulated through work practice standards. The commenters also recommend that the rule provide a proposed timeline for repair or replacements, as well as delay-of-repair provisions, consistent with nearly all other NSPS drafted by the EPA.

According to one commenter,⁴⁸⁴ the EPA, without sufficient explanation, summarily turned California's work practice standard into an emissions rate limitation. The commenter alleged there is nothing in the record about what measures would need to be

implemented, and the associated cost, to meet such a limitation. The commenter stated that a delay-of-repair provision in such a regulatory scheme appropriately recognizes that the unit must be shut down to effect any such repair and replacement and that parts availability and supply chain disruptions may be relevant to how quickly the repair or replacement can be made. In addition, the commenter stated there is no record information indicating that it is feasible for the source to anticipate that a well-functioning wet seal that meets the 3 scfm limitation for 1 year will exceed it before the next year's test, or the cost of doing so (if possible).

Several commenters⁴⁸⁵ suggested that the EPA allow one of the following corrective actions by an operator within 2 years if the applicable flow rate performance standard is exceeded:

- (1) repair or replace the dry seal, wet seal, or internal seal gas recovery system; and
- (2) route emissions from the dry seal vent through a closed vent system or from the degassing vent using a cover and closed vent system a control device; or
- (3) route emissions from the primary dry seal vent through a closed vent system or route the degassing vent using a cover and closed vent system to a process.

The commenters⁴⁸⁶ recommended that if an operator cannot complete the corrective action within 2 years, then a corrective action plan with work scope and alternate schedule be submitted to the EPA under a work-practice-based framework. According to the commenters, 2 years is a reasonable corrective action period since the corrective actions listed can require significant planning, scheduling, engineering, and construction. They explain that exceedance of the flow rate performance standard after 2 years (in the absence of a corrective action plan), or after the time stated in the corrective action plan, would result in a deviation subject to recordkeeping and reporting requirements similar to other types of compressors.

Some commenters⁴⁸⁷ stated that the delay-of-repair provision is consistent with delay-of-repair requirements under 40 CFR 60.5397a(h)(3), requiring repair within 2 years, or the next scheduled shutdown (whichever is earlier), where repairs are technically infeasible, where repairs would require a vent blowdown,

⁴⁸² EPA-HQ-OAR-2021-0317-2258, -2282, -2305, -2326, -2399, -2428, and -2483.

⁴⁸³ See, *e.g.*, 87 FR at 74711-12 (table 3).

⁴⁸⁴ EPA-HQ-OAR-2021-0317-2483.

⁴⁸⁵ EPA-HQ-OAR-2021-0317-2282, -2305, -2399, and -2428.

⁴⁸⁶ EPA-HQ-OAR-2021-0317-2282, -2305, -2399, and -2428.

⁴⁸⁷ EPA-HQ-OAR-2021-0317-2282 and -2399.

a compressor station shutdown, a well shutdown, or well shut-in, or where it would be unsafe to repair. Further, the commenters added that the EPA has taken this approach before in most of its NSPS regulations.⁴⁸⁸ In fact, the EPA has also proposed a delay-of-repair approach in other contexts of the December 2022 Supplemental Proposal for the NSPS where emissions caused by the repair would exceed the existing leak rate.⁴⁸⁹

One commenter⁴⁹⁰ suggested 90 days as a reasonable timeframe given the significant variety of repair methods (including replacement) that may be appropriate for these units, as the EPA recognizes in its preamble.

Several commenters⁴⁹¹ proposed revisions to regulatory language to implement the requested work practice approach and delay-of-repair provision.

Response: The EPA acknowledges that the record for the 3 scfm per seal volumetric flow rate performance standard supports a work practice standard and not a numeric standard for centrifugal compressors equipped with wet seals. This is because the application of a measurement methodology to centrifugal compressors is not always practicable due to technological or economic limitations. It is not practicable here for an exceedance of the 3 scfm per seal volumetric flow rate to be a violation when the annual performance-based flow rate reflects whether there are performance issues with a seal that need to be addressed in order to take action to minimize the emissions/leak. This is similar to the basis and monitoring established for fugitive emissions component requirements, where a leak based on periodic monitoring triggers requirements to minimize the emissions/leak.

The final rule has therefore been revised so that the format of the 3 scfm per-seal performance-based volumetric flow rate performance standard for compressors equipped with wet seals is implemented as a work practice standard and not as a numeric limit

where an exceedance would be considered a violation. Specifically, the final rule for reducing GHGs and VOC from new centrifugal compressors is repair or replacement of the wet seal where, based on the required monitoring, the per-seal volumetric flow rate performance standard is exceeded. If the volumetric flow rate measurement of the centrifugal compressor is greater than 3 scfm (in operating or standby pressurized mode) or a combined compressor seal rate greater than the number of compressor seals multiplied by 3 scfm, an owner or operator must repair or replace the centrifugal compressor seal within 30 calendar days after the date of the volumetric emissions measurement. As such, for centrifugal compressors equipped with wet seals, the volumetric flow rate of 3 scfm is an action level that, if exceeded, triggers the action of repairing or replacing the seal and is not a numeric limit.

Delay-of-repair provisions under a work practice standard appropriately recognize that the unit must be shut down to affect any such repair and replacement and that parts availability and supply chain disruptions may be relevant to how quickly the repair or replacement can be made. As such, the final rule allows for a delay of repair if the repair or replacement would require a vent blowdown, or it would otherwise be infeasible or unsafe, until the next process unit shutdown. Specifically, delay of repair would be allowed if the repair or replacement of a seal (1) is technically infeasible, (2) would require a vent blowdown, (3) would require a process unit or facility to shut down, (4) needs to be delayed because parts or materials are unavailable, or (5) would be unsafe to repair during operation of the unit. In cases where there is a need for a delay of repair, the repair must be completed during the next scheduled process unit or facility shutdown for maintenance, after a scheduled vent blowdown, or within 2 years, whichever is earliest.

Delay-of-repair provisions under a work practice standard appropriately recognize that the unit must be shut down to effect any such repair and replacement and that parts availability and supply chain disruptions may be relevant to how quickly the repair or replacement can be made. As such, the final rule allows for a delay of repair if the repair or replacement would require a vent blowdown, or it would otherwise be infeasible or unsafe, until the next process unit shutdown. Specifically, delay of repair would be allowed if the repair or replacement of a seal (1) is technically infeasible, (2) would require

a vent blowdown, (3) would require a process unit or facility to shut down, (4) needs to be delayed because parts or materials are unavailable, or (5) would be unsafe to repair during operation of the unit. In cases where there is a need for a delay of repair, the repair must be completed during the next scheduled process unit or facility shutdown for maintenance, after a scheduled vent blowdown, or within 2 years, whichever is earliest. Delay of repair beyond the next scheduled compressor shutdown for maintenance is allowed for a centrifugal compressor wet and dry seal, if seal replacement is necessary during the compressor shutdown for maintenance, seal supplies have been depleted, and seal supplies had been sufficiently stocked before the supplies were depleted. Delay of repair beyond the next compressor shutdown for maintenance will not be allowed unless the next compressor shutdown for maintenance occurs sooner than 6 months after the first compressor shutdown for maintenance.

The format of the volumetric flow rate performance standard for centrifugal compressors equipped with dry seals has also been revised in the final rule as a work practice standard and not as a numeric limit. However, for centrifugal compressors equipped with dry seals, the volumetric flow rate performance standard is 10 scfm per seal and not 3 scfm per seal (see section XI.G.1 of this document for discussion on centrifugal compressors with dry seals). As such, for centrifugal compressors equipped with dry seals, the volumetric flow rate of 10 scfm is an action level that, if exceeded, triggers the action of repairing or replacing the seal and is not a numeric limit.

3. Clarification That the Standard Is Based on a Per-Seal Basis

Comment: Several commenters⁴⁹² requested clarification that the volumetric standard applies to each seal and not each compressor and that the rule text clearly address manifolded vents on a combined basis to reflect this. The commenters cited the precedent set by the CARB where wet seal compressors in California are restricted to 3 scfm per seal, and not per compressor as set forth in 17 Code of Colorado Regulations (CCR) section 95668.

One of the commenters⁴⁹³ noted that the EPA's preamble discussion, and at least some of the proposed rule text, imply that the emissions rate would be

⁴⁸⁸ See, e.g., 40 CFR 60.482–9(c)(1) (delay of repair allowed if emissions of purged material resulting from immediate repair are greater than the fugitive emissions likely to result from delay of repair), and 40 CFR 60.5416(b)(10) (delay of repair permitted if emissions resulting from immediate repair would be greater than the fugitive emissions likely to result from delay of repair).

⁴⁸⁹ See, e.g., proposed 40 CFR 60.5400b(h)(6)(ii)(A) (Delay of repair showing requires in part "that emissions of purged material resulting from immediate repair are greater than the fugitive emissions likely to result from delay of repair.").

⁴⁹⁰ EPA–HQ–OAR–2021–0317–2282.

⁴⁹¹ EPA–HQ–OAR–2021–0317–2282 and –2483.

⁴⁹² EPA–HQ–OAR–2021–0317–2258, –2282, –2305, –2366, –2399, –2428 and –2483.

⁴⁹³ EPA–HQ–OAR–2021–0317–2282.

on a per-seal basis, and the commenter understands this to be the EPA's intent. The commenter asserted that it is important that the EPA's final rule more clearly reflect this intent. Specifically, according to the commenter, the proposed text provided in 40 CFR 60.5380b or 40 CFR 60.5385b(a) (and parallel EG OOOOc language) does not provide the distinction that the limits are per seal. The commenter asserted that it would be impractical for a compressor with multiple seals (centrifugal) to operate in the same way as a compressor with only a single seal.

The commenter⁴⁹⁴ stated that the rule language must more clearly address manifolded vents on a combined basis. The commenter noted that the December 2022 Supplemental Proposal preamble provided that the manifolded wet and dry seal flow rate must be "less than or equal to the number of compressors multiplied by 3 scfm (in operating or standby pressurized mode)." The commenter supported this approach, as it reflects the practicalities of measuring emissions from manifolded seals. The commenters also note that the approach is supported by the 2006 Natural Gas STAR report, which states that emissions rates from two seal systems would be double the emissions from a single seal system.

The commenters elaborated on why they believed that this was the EPA's intent (for the standard to be based on a per-seal basis) and several commenters provided in-line regulatory text changes where they believed the clarification was needed.

Response: The EPA agrees that the basis and intent of the standard is that it be applied on a per-seal basis and that clarity was needed in the NSPS OOOOb and EG OOOOc regulatory text. The final rule regulatory text has been revised to make this clear as suggested by the commenters. Specifically, clarifying changes have been made to 40 CFR 60.5380b, paragraphs (a)(5) through (7) of NSPS OOOOb, and 40 CFR 60.5392c, paragraphs (a)(1) and (2), of EG OOOOc.

4. Other Inherently Low-Emitting Compressor With Wet Seal Configurations

Comment: In their comments on the November 2021 Proposal, one commenter⁴⁹⁵ stated that one type of low-emissions wet seal utilized in compressors in the transmission and storage sector is a mechanical seal, in which metal (tungsten carbide) is seated against carbide, with oil pressing against

the outside of the actual seal. Because the oil is not in contact with the natural gas, the commenter explains that these wet seals have generally zero degassing emissions. According to the commenter, it makes no sense to subject such a zero-emissions wet seal to control requirements. Accordingly, the EPA should exclude compressors utilizing mechanical wet seals from the requirements otherwise applicable to wet seal compressors.

The commenter⁴⁹⁶ provided additional information on mechanical seals in their comments on the December 2022 Supplemental Proposal for the EPA to evaluate that provided support that, with respect to mechanical wet seals, when a differential pressure is maintained on the system, there is no off-gassing of the lube oil. The commenter attached an example to their comment letter that shows that the oil is pumped via the seal oil pump to the seal gas bottle, when the seal oil pressure is maintained at 32 psi above discharge gas pressure.

Response: The EPA has evaluated the information provided by the commenter on mechanical seals for both the November 2021 Proposal and the December 2022 Supplemental Proposal. The EPA has made the determination that mechanical wet seals are inherently low-emitting where (1) a differential pressure is maintained on the system, (2) there is no offgassing of the lube oil, and (3) the mechanical seal is integrated into the compressor housing. As such, the final rule definition of self-contained wet seal compressor has been revised, for purposes of regulation, to include mechanical wet seals where (1) a differential pressure is maintained on the system, (2) there is no off-gassing of the lube oil, and (3) the mechanical seal is integrated into the compressor housing. Self-contained wet seal centrifugal compressors are allowed to meet a 3 scfm/seal volumetric flow rate limit in lieu of being required to route emissions via a CVS to a control device or process under NSPS OOOOb.

5. Applicability of Requirements to Compressors Located at Centralized Production Facilities

The EPA proposed in the November 2021 Proposal⁴⁹⁷ to define centralized production facilities separately from well sites because the numbers and sizes of equipment, particularly reciprocating and centrifugal compressors, are larger than for standalone well sites, which would not

be included in the proposed definition of "centralized production facilities." In the 2016 NSPS OOOOa, the EPA exempted reciprocating and centrifugal compressors located at well sites from the applicable compressor standards. However, the EPA believed the definition of "well site" in NSPS OOOOa may have caused confusion regarding whether centrifugal compressors located at centralized production facilities were also exempt from the standards, which was not our intent.

To clarify our intent, the EPA defined centralized production facility as follows in the December 2022 Supplemental Proposal in both the NSPS OOOOb and EG OOOOc:

Centralized production facility means one or more storage vessels and all equipment at a single surface site used to gather, for the purpose of sale or processing to sell, crude oil, condensate, produced water, or intermediate hydrocarbon liquid from one or more offsite natural gas or oil production wells. This equipment includes, but is not limited to, equipment used for storage, separation, treating, dehydration, artificial lift, combustion, compression, pumping, metering, monitoring, and flowline. Process vessels and process tanks are not considered storage vessels or storage tanks. A centralized production facility is located upstream of the natural gas processing plant or the crude oil pipeline breakout station and is a part of producing operations.

Additionally, the EPA defined the affected facility under the NSPS OOOOb (and designated facility under EG OOOOc) as:

(b) Each centrifugal compressor affected facility [and designated facility under the EG OOOOc], which is a single centrifugal compressor. A centrifugal compressor located at a well site is not an affected facility under this subpart. A centrifugal compressor located at a centralized production facility is an affected facility under this subpart.

For purposes of analyses, the EPA determined it was appropriate to apply the same emission factors to centrifugal compressors located at centralized production facilities as those used for centrifugal compressors at gathering and boosting compressor stations. Given the results of that analysis, the EPA proposed to apply the proposed NSPS OOOOb requirements to centrifugal compressors located at centralized production facilities. At that time, the EPA proposed a new definition for "centralized production facility" intended to distinguish compressors at standalone well sites where the EPA has determined that the standard should not apply.

⁴⁹⁴ EPA-HQ-OAR-2021-0317-2282.

⁴⁹⁵ EPA-HQ-OAR-2021-0317-0415 and -1391.

⁴⁹⁶ EPA-HQ-OAR-2021-0317-2483.

⁴⁹⁷ See 86 FR 63110 at 63184-85 (November 15, 2021).

Comment: One commenter⁴⁹⁸ requested that the EPA clarify the applicability of compressor standards to well sites. The commenter stated that the definition proposed for central[ized] production facilities may extend applicability to compressors located at well sites, which have historically been exempt from the compressor standards. As the EPA stated they have not updated their cost analyses with new information with respect to well sites, the commenters believe that extending applicability to well sites was not the EPA's intent. Another commenter⁴⁹⁹ urged the EPA to keep the current compressor exemptions shown in both subparts NSPS OOOO and OOOOa. The commenter specifically requests that the EPA maintain that each compressor "located at a well site, or an adjacent well site and servicing more than one well site, is not an affected facility."

Response: The EPA has finalized the proposed requirements related to the definitions of the centrifugal compressor affected facility/designated facility and centralized production facility. Some of the commenters suggested that, by extending requirements to centralized production facilities, the EPA was extending requirements to well sites where centrifugal compressors were not previously regulated. That interpretation confirms that clarity was needed. Based on the proposed definition of the centrifugal compressor affected facility/designated facility, in addition to the proposed definition for centralized production facility as proposed in the December 2022 Supplemental Proposal, we believe that we clarified our intent. That intent is that centrifugal compressors located at well sites are not subject to requirements. However, centrifugal compressors located at centralized production facilities that consist of equipment at a single surface site used to gather, for the purpose of sale or processing to sell, crude oil, condensate, produced water, or intermediate hydrocarbon liquid from one or more offsite natural gas or oil production wells (including centrifugal compressors) are subject to centrifugal compressor requirements.

6. Wet Seal Compressors Equipped With a Seal Oil Gas Separation System Utilized on the Alaska North Slope (ANS)

Comment: One commenter⁵⁰⁰ representing Alaska oil and natural gas companies requested that the EPA

revise the proposed EG for existing wet seal centrifugal compressors to address the characteristics of the wet seal compressors deployed in Alaska oil production operations. The commenter reported that their members use wet seal compressors at their Alaska North Slope (ANS) and Cook Inlet production fields to increase the pressure of residual gas captured in production operations to enable delivery to gas processing plants and/or reinjection into well fields. They noted that there are about 40 compressor trains on the ANS installed for this purpose. The compressors in use on the ANS were installed in the late 1970s through mid-1980s and have not been modified or reconstructed. They range in size from 15,140 hp to 53,665 hp. None are currently subject to NSPS OOOO or NSPS OOOOa.

The commenter stated that all the wet seal centrifugal compressors in Alaska are equipped with a seal oil gas separation system that separates gas from the sour seal oil exiting the compressor seal assembly, upstream from the degassing drum. On the ANS the gas captured in the seal oil trap is routed to various outlets for use as turbine fuel, low-pressure fuel gas, compressor suction, flare purge or to flare (for destruction). In Cook Inlet the gas is processed for delivery to market. The commenter noted that the EPA described this technology enthusiastically in the 2014 Natural Gas STAR Report.⁵⁰¹ Sour seal oil passes through a "seal oil trap," a type of separator, prior to routing to the seal oil degassing drum. The commenter described the seal oil traps in their comments on the November 2021 Proposal, which they resubmitted on the December 2022 Supplemental Proposal. The commenter included a process flow diagram of the seal oil recovery system on an ANS wet seal compressor. The commenter added that the EPA's 2014 Natural Gas STAR Report praised the seal gas recovery system deployed on the ANS as "highly effective at capturing degassing emissions from wet seal centrifugal compressors . . ." ⁵⁰²

While the commenter supported the concept of adopting a volumetric limit based on diligent maintenance and repair as BSER for control of emissions from wet seal compressor vents, they asserted that the record does not support that the proposed 3 scfm limit can be met for all wet seal compressors. The commenter expressed support for

the concept of adopting a flow rate limit based on maintenance and repair as BSER for control of emissions from wet seal compressor vents because they believe that such an option avoids the safety risks, engineering challenges, and extravagant cost of capturing and flaring low-volume, low-pressure vent streams. They asserted that the problem with the EG OOOOc proposal is that the 3 scfm proposed limit does not account for variability in the size and configuration of wet seal compressors within the source category and is not demonstrated or achievable for wet seal compressors of the size and configuration of those deployed in oil and gas production operations in Alaska.

The commenter stated that they would support the designation of seal oil traps as an EG OOOOc compliance option for Alaska wet seal compressors. For several reasons, however, Alaska wet seal compressors equipped with seal oil traps do not uniformly meet the proposed 3 scfm limit. They explained that the volume of seal oil slip from a wet seal compressor correlates with compressor shaft size, pressure, and speed. Alaska wet seal compressors span a broad range of capacities, and the degassing drums serving the larger units vent higher volumes of seal gas. Attachment C to their comments provides a table showing flow rate data from 27 wet seal compressor degassing vents sampled by AOGA member Hilcorp for the EPA GHG emissions reporting. The table shows the flow rate per seal, but a single degassing drum can discharge gas from up to four seal oil traps. The variability in the data reflects the variability in size and configuration of the compressors and the fact that each seal oil trap operates on a discharge cycle, and a degassing drum may receive sour seal oil from up to four different seal oil traps at any moment. Depending on when in the cycle the sample is taken, the per-seal flow rate can exceed 3 scfm.

Based on the degassing drum flow rate data summarized in table 1 (of attachment C to their comment letter), the commenter proposed a volumetric flow limit for Alaska wet seal compressor vents of 9 scfm of methane and VOCs per seal, multiplied by the number of compressor seals venting through a common stack. For example, they note that a two-stage compressor has four seals (two per stage), all of which are manifolded into one vent to the atmosphere. If the per-seal flow limit was 9 scfm, the flow limit for the common vent should be 36 scfm.

Response: The EPA reviewed information materials submitted by commenters related to the wet seal

⁵⁰¹ EPA, Wet Seal Degassing Recovery System for Centrifugal Compressors (2014) at 3 ("2014 Natural Gas STAR Report"), included as attachment A to their comment letter.

⁵⁰² 2014 Natural Gas STAR Report.

⁴⁹⁸ EPA-HQ-OAR-2021-0317-0808.

⁴⁹⁹ EPA-HQ-OAR-2021-0317-0923.

⁵⁰⁰ EPA-HQ-OAR-2021-0317-2317.

centrifugal compressors in Alaska equipped with a seal oil gas separation system that separates gas from the sour seal oil exiting the compressor seal assembly, upstream from the degassing tank. These compressors are considered inherently low-emitting based on Natural Gas STAR and emissions/process information provided by the commenter. These wet seal compressors with the sour seal oil traps recapture gas and route the gas to the flare (simple pit flares), not to the “compressor suction [as with defined self-contained wet seal compressors].” These systems cannot always meet a 3 scfm limit due to the intermittent process affecting flow.

The final EG OOOOc rule provides a new definition for a “centrifugal compressor equipped with sour seal oil separator and capture system” and requires that, in Alaska, such compressors be allowed to meet a performance-based volumetric flow rate standard of 9 scfm/seal, in lieu of the 3 scfm/seal performance-based volumetric flow rate standard to account for the variability in the flow rate data provided by the commenter that reflects the variability in size and configuration of these compressors and the fact that each seal oil trap operates on a discharge cycle, and a degassing drum may receive sour seal oil from up to four different seal oil traps at any moment.

The final rule definition reads as follows:

Centrifugal compressor equipped with sour seal oil separator and capture system means a wet seal centrifugal compressor system which has an intermediate closed process that degasses most of the gas entrained in the sour seal oil and sends that gas to either another process or combustion device. The de-gas emissions are routed back to a process or combustion device directly from the intermediate closed degassing process; after the intermediate closed process the oil is ultimately recycled for recirculation in the seals to the lube oil tank where any small amount of residual gas is released through a vent.

Comment: In addition to the commenter’s⁵⁰³ concerns related to the proposed volumetric performance-based standard requirement, the commenter added that the NSPS OOOOb capture and control requirements for new wet seal compressors are also not reasonably achievable for existing compressors in Alaska. The commenter noted that the December 2022 Supplemental Proposal’s proposed EG OOOOc offers the NSPS OOOOb control options as a fallback for wet seal compressors that cannot meet the presumptive 3 scfm flow limit, but they stated that these

options would require a cover on the degassing drums, connected through a closed vent system to process or to a control device that achieves a 95.0 percent reduction in emissions, should an existing compressor ever be modified or reconstructed. The commenter stated that in Alaska oil and gas production operations there is no cost-effective option to recover degassing drum emissions. Degassing drums vent small volumes of methane and VOCs at atmospheric pressure. They referred to flow rates reported in attachment C⁵⁰⁴ of their comment letter. They explained that the volumes reported are small because the seal oil traps capture and recycle most of the seal gas upstream of the degassing drum. They reported that operators would need to install new compression devices to boost degassing drum vent gas pressure to the approximately 20 psi that would enable delivery of those streams to the flare header line. The commenter stated that larger new compression devices would be required to boost vent gas to a much higher pressure that would enable delivery to a process line for injection into subsurface reservoirs.

According to the commenter, the combination of low methane and VOC recoveries with high capture costs makes the capture and control alternative very expensive on a cost-per-ton basis. They referred to Kinder Morgan’s comments on the November 2021 Proposal, where Kinder Morgan provides that the 95.0 percent reduction requirement is technically infeasible and cost-prohibitive even for wet seal compressors located on natural gas pipelines in the lower 48 states.^{505 506} For wet seal compressors deployed in Alaska production operations with seal oil traps, the cost per ton of covering the degassing drum vents and reducing emissions from those vents by 95.0 percent would be prohibitive.

Response: As discussed earlier in this document, the EPA agrees that ANS compressors equipped with a sour seal oil separator and capture system are inherently low-emitting and that the

⁵⁰⁴ Attachment C—Table of data titled, “Hilcorp Alaska Wet Seal Combustion Turbines, Volumetric Flow Rate Per Seal (2016–2011). (Attachment C of their comment letter.)

⁵⁰⁵ Comments of Kinder Morgan Inc. on EPA Proposed Standards and Emissions Guidelines for the Oil and Natural Gas Sector at 8–20, Document ID No. EPA-HQ-OAR-2021-0317-1375 (“Kinder Morgan Comments”).

⁵⁰⁶ The “lower 48” consists of the 48 adjoining U.S. states and the District of Columbia of the United States of America. The term excludes the only two noncontiguous states, which are Alaska and Hawaii, and all other offshore insular areas, such as the U.S. territories of American Samoa, Guam, the Northern Mariana Islands, Puerto Rico, and the U.S. Virgin Islands.

costs of requiring routing to a control device or process would be cost-prohibitive for these compressors due to technical and costly retrofits that would be needed (e.g., would need to install new compression devices to boost degassing drum vent gas pressure) if any of their existing ANS compressors were to be modified or reconstructed. The commenters provided information and data to support their request that these sources be allowed to meet a performance-based volumetric flow rate standard in lieu of having to route emissions to a control device or process. As provided by the commenter, and the EPA agrees, recovering degassing drum emissions that vent small volumes of methane and VOC at atmospheric pressure because the seal oil traps capture and recycle most of the seal gas upstream of the degassing drum would not be cost-effective. The final standards for NSPS OOOOb have been revised to be consistent with what is being required under the EG OOOOc presumptive standards. As such, the NSPS OOOOb final rule has been revised to include a new definition for a “centrifugal compressor equipped with sour seal oil separator and capture system” and requires that, in Alaska, such compressors be allowed to meet a performance-based volumetric flow rate standard of 9 scfm/seal. The volumetric flow rate of 9 scfm is an action level that, if exceeded, triggers the action of repairing or replacing the seal and is not a numeric limit.

H. Combustion Control Devices

In section X.H of this preamble, the final NSPS OOOOb and EG OOOOc requirements for combustion control devices are summarized. The rationale for the proposed requirements was presented in the December 2022 Supplemental Proposal in section IV.H. Combustion Control Devices.⁵⁰⁷ This section of the preamble presents a summary of significant comments received on the proposed requirements for combustion control devices and the EPA’s response to those comments, as well as changes the EPA has made to the control device requirements since the December 2022 Supplemental Proposal. The EPA’s full response to comments on the November 2021 Proposal and December 2022 Supplemental Proposal, including any comments not discussed in this preamble, can be found in the EPA’s RTC document for the final rule.⁵⁰⁸

⁵⁰⁷ See 87 FR 74792–74796 (December 6, 2022).

⁵⁰⁸ *Standards of Performance for New, Reconstructed, and Modified Sources and*

1. Outlet Concentration Limit

Comment: Some commenters⁵⁰⁹ wanted to ensure that the concentration limit included in NSPS OOOOa for existing enclosed combustors will continue to be allowed in NSPS OOOOb and EG OOOOc. One commenter⁵¹⁰ explained that destruction efficiency testing requires VOC sampling at the inlet and outlet of the control device but that many existing control devices do not have an inlet sampling port. The commenter notes that combined with the potential need to install additional monitoring equipment, allowing the use of a 20 ppm concentration limit will provide facilities that do not have inlet testing ports an alternative to meet compliance requirements for both NSPS OOOOb and EG OOOOc. Another commenter⁵¹¹ stated that the continuous monitoring option for organic compound concentration in the control device exhaust is meaningless without the corresponding outlet concentration performance standard. Additionally, the commenter requested that the EPA clarify how operators should handle compliance for existing control devices that are complying with the total organic compound concentration standard under NSPS OOOO or OOOOa.

Response: The EPA agrees that it is likely that most enclosed combustion devices that are being used to control affected facilities in NSPS OOOO and NSPS OOOOa demonstrate compliance during the performance test with the alternative outlet concentration limit instead of testing both the inlet and outlet of the control device. It remains the EPA's position that it is reasonable to allow owners and operators to continue to demonstrate compliance for these units with an outlet concentration. It is also plausible that owners and operators will have affected facilities under both NSPS OOOOb and EG OOOOc controlled by the same enclosed combustion device, and so we are adding the outlet concentration limit to both NSPS OOOOb and EG OOOOc.

In response to the comments received, the EPA is adding an outlet concentration limit of 275 ppm volume as propane on a wet basis to both NSPS OOOOb and EG OOOOc. This is the same outlet concentration limit that is in NSPS OOOO and NSPS OOOOa. We

Emissions Guidelines for Existing Sources: Oil and Natural Gas Sector Climate Review. Response to Public Comments on the November 2021 Proposed Rule and the December 2022 Supplemental Proposed Rule (86 FR 63110, November 15, 2021; 87 FR 74702, December 6, 2022).

⁵⁰⁹ EPA-HQ-OAR-2021-0317-2399 and -2428.

⁵¹⁰ EPA-HQ-OAR-2021-0317-2399.

⁵¹¹ EPA-HQ-OAR-2021-0317-2428.

anticipate that carrying over this limit would not require a new performance test for most of these existing control devices until the next periodic performance test is due or until operation of the control device changes in a manner that warrants a new performance test.

2. Monitoring Flares

Comment: A commenter⁵¹² stated that while they support the requirements for no visible emissions and for monthly monitoring using EPA Method 22, the EPA could also consider alternative monitoring technologies and methods that would achieve equivalent or superior results. The commenter urged the EPA to also require flares and control devices to be monitored for compliance assurance during all fugitive emissions surveys, both under the OGI and AVO program and under the alternative periodic screening options. The commenter noted that control devices and flares, especially unlit and malfunctioning flares, are among the most observed and largest sources of methane emissions, and it is therefore critical that they are regularly inspected and monitored to ensure proper operation.⁵¹³ The commenter further stated that multi-basin research has identified unlit flares across the entire country, and a Permian Basin study using flights conducted in 2020 found that 5 percent of all active flares were unlit.⁵¹⁴ Moreover, the commenter contends that monitoring flares and control devices during fugitive emissions surveys poses very little additional burden and can ensure emissions events are avoided.

Response: The EPA agrees that requiring owners and operators to check flare operation during a fugitive emissions inspection adds little additional burden and can help to reduce the incidence of unlit flares. This is something some owners and operators already do in practice, because in reviewing reports submitted under NSPS OOOOa, we noted that many owners and operators listed flares in the fugitive emissions report. Additionally,

⁵¹² EPA-HQ-OAR-2021-0317-2433.

⁵¹³ The commenter cited to Genevieve Plant, *et al.*, *Inefficient and Unlit Natural Gas Flares Both Emit Large Quantities of Methane*, 377 *Sci.* 6614 (2022), <https://www.science.org/doi/10.1126/science.abq0385>, and Daniel H. Cusworth, *et al.*, *Intermittency of Large Methane Emitters in the Permian Basin*, 8 *Env't Sci. Tech. Letters* 567 (2021), <https://pubs.acs.org/doi/abs/10.1021/acs.estlett.1c00173>, as examples.

⁵¹⁴ The commenter cited to David R. Lyon, *et al.*, *Concurrent Variation in Oil and Gas Methane Emissions and Oil Price During the COVID-19 Pandemic*, 21 *Atmos. Chem. Phys.* 6605 (2021), <https://acp.copernicus.org/articles/21/6605/2021/>.

for technologies used under the provisions of the periodic screening and continuous monitoring advanced methane detection technology work practices in the final NSPS OOOOb and EG OOOOc, we anticipate that by the nature of the operation of these technologies, these technologies will detect unlit flares. Therefore, requiring owners and operators to look at flares during an OGI inspection will also help to even the playing field for all technologies used in fugitive emissions monitoring. In the final rule, we are requiring owners and operators to view the operation of their flares with an OGI camera during fugitive emissions inspections conducted with OGI to ensure that the flare is lit and that there are no uncontrolled emissions coming from the flare. We are also requiring owners and operators to ensure that the flare is operating properly during AVO inspections by visually confirming that the pilot flame is lit and operating properly.

Comment: A commenter⁵¹⁵ stated that with respect to the alternative to continuous flow monitoring, the EPA must include requirements to reassess the engineering assessment when there are changes to the sources vented to the flare, such as when additional sources are routed to the control device, or those upstream sources change, because the flow rate could increase, and proper destruction efficiency would not be ensured.

Response: The EPA agrees with the commenter that the assessment for maximum flow rate to an enclosed combustor or flare must be updated when there are changes to the device's operation that are expected to impact the initial assessment. We have revised the language in the final rule to reflect this requirement.

3. Visible Emissions Observations

Comment: Commenters suggested that the EPA should permit the use of cameras for operators to perform visual inspections of flare and combustor smoke under EPA Method 22.⁵¹⁶ Visible light cameras such as security cameras are widely available and deployed at oil and gas sites, and they can be positioned such that they can view potential smoke from combustors and flares. Therefore, commenters request that the EPA clarify that operators can utilize visible light cameras to remotely observe flares and combustors for smoke and specify installation and operation requirements such cameras need to

⁵¹⁵ EPA-HQ-OAR-2021-2362.

⁵¹⁶ EPA-HQ-OAR-2021-0317-2336, -2428, -2298, and -2326.

meet. Another commenter⁵¹⁷ noted that video camera systems are allowed as an alternative to EPA Method 9 observation under broadly applicable approved Alternative Test Method 82 (ALT-082).⁵¹⁸ Commenters also suggested that artificial intelligence and machine learning should be allowed to continuously screen the video feed for smoke detection and if smoke is detected, alert the operator that an EPA Method 22 follow-up is required.⁵¹⁹

Response: The EPA agrees that camera systems that monitor for visible emissions are a viable alternative to monthly EPA Method 22 observations for this sector, and there is already precedent for use of such systems in refineries under 40 CFR part 63, subpart CC. Therefore, the EPA has added the option to use a camera system for visible emissions observations to the final rule. In order for an owner or operator to use this option, the owner or operator must provide real-time, high-definition video surveillance camera output to the nearest control room or other continuously manned location where the camera images may be viewed at any time, with the output recorded continuously. The camera must be located at a reasonable distance above the flare flame and no further than 400 meters from the emissions source, at an angle suitable for visual emissions observations with the sun not in the field of view. With this option, observation via the video camera feed can be conducted readily throughout the day and will allow the operators of the flare to watch for visible emissions more frequently. The operator must document that they observed the camera feed for at least one minute each day. We note that this option is not the same as the digital opacity camera alternative outlined in ALT-082 which is not applicable in this rulemaking, as there is no opacity limit in the rule.

The EPA has not added an option that allows for automated viewing of the camera feed with artificial intelligence or machine learning, because we have no information demonstrating that these systems work effectively or under what circumstances these systems may encounter problems with adequately identifying visible emissions. Owners or operators are welcome to use such systems in addition to the requirements of the rule.

4. Measurement of NHV

Comment: Several commenters⁵²⁰ were concerned with the proposed NHV monitoring provisions for flares, which would require continuous monitoring of the NHV unless the initial NHV sampling demonstration (hourly sampling for 10 days) shows that the NHV is consistently above the applicable NHV value, which is dependent on the flare type. Commenters stated that the initial NHV sampling demonstration to show that the NHV of a gas stream is always above the required NHV in 40 CFR 60.18(b) is unnecessarily burdensome and is even more burdensome than what is required for refineries.⁵²¹ Commenters suggest that the proposed initial NHV sampling demonstration as an alternative to continuous NHV monitoring should be simplified, because the NHV of vent streams from affected facilities is typically fixed or well above the minimum NHV requirements, as these vent streams consist of mostly hydrocarbons and the simplest hydrocarbon has a NHV of approximately 900 British thermal units per standard cubic foot (Btu/scf), which is well above the minimum NHV requirement proposed by the EPA. One commenter⁵²² provided data collected from laboratories that analyze samples of associated gas and flared gas in North Dakota. Out of 7,774 gas samples collected and analyzed from 2020 through 2022, the average NHV was 1,459 Btu/scf, while the maximum and minimum values were 1,007 and 2,846 Btu/scf.

One commenter⁵²³ stated that since the vent streams from affected facilities are expected to have sufficient heating value, both the proposed continuous NHV monitoring and the initial NHV sampling demonstration are economically unreasonable. For the minimum NHV demonstration alternative, the commenter reports that the cost is expected to be \$250,000 or more per demonstration. The commenter summarizes that the cost of a vendor-conducted 10-day continuous monitoring campaign for the initial NHV sampling demonstration is estimated at a minimum of \$250,000 to \$275,000 while the cost of 200 hourly samples is estimated at a total of \$300,000 to \$400,000 with an average

cost per sample of \$1,500 to \$2,000 including shipping and analysis.

One commenter⁵²⁴ suggested that the EPA require a 10-day test period with one sample every 6 hours, for a total of 40 sample analyses. Another commenter⁵²⁵ proposed a simplified sampling protocol for samples to be taken twice a day for 7 days. A third commenter⁵²⁶ stated that the 10-day initial NHV sampling demonstration should be simplified to a single sample including the use of an appropriate, representative sample or an initial flare compliance assessment under 40 CFR 60.18, with the operator documenting why the sample is characteristic of the vent stream composition. After the initial NHV sampling demonstration, continuous compliance would be demonstrated through subsequent samples once every 3 years. The commenters also stated that neither the continuous NHV monitoring nor the initial NHV sampling demonstration alternative should be required if operators can demonstrate that the NHV is never expected to be below the minimum required value using a design evaluation or applicable engineering calculations including process simulation software and pressurized liquids sampling. One commenter⁵²⁷ stated that continuous monitoring of NHV presents inaccuracy issues associated with low or intermittent gas streams due to technological limits. While the commenter agrees with the availability of the initial NHV sampling demonstration in lieu of continuous monitoring, the commenter requested that the EPA allow operators to periodically (*i.e.*, quarterly) sample representative inlet gas streams to demonstrate compliance with any applicable heating value requirement for control devices used to control affected facilities with intermittent or low flow gas streams under this rule.

A different commenter⁵²⁸ stated that the EPA must require direct NHV monitoring at all oil and gas flares and combustion devices on a continuous basis. The commenter states the NSPS general provisions mandate that the Agency establish monitoring for the general provisions' NHV operating limits, especially since the general provisions themselves contain no monitoring requirements for this limit. The commenter also stated that the EPA correctly concludes that the current operating and monitoring practices and

⁵²⁰ EPA-HQ-OAR-2021-0317-2248, -2305, -2326, -2353, -2399, and -2428.

⁵²¹ The commenter pointed to 40 CFR 63.670(j)(6)(D).

⁵²² EPA-HQ-OAR-2021-0317-2248.

⁵²³ EPA-HQ-OAR-2021-0317-2428.

⁵²⁴ EPA-HQ-OAR-2021-0317-2305.

⁵²⁵ EPA-HQ-OAR-2021-0317-2399.

⁵²⁶ EPA-HQ-OAR-2021-0317-2428.

⁵²⁷ EPA-HQ-OAR-2021-0317-2298.

⁵²⁸ EPA-HQ-OAR-2021-0317-2362.

⁵¹⁷ EPA-HQ-OAR-2021-0317-2428.

⁵¹⁸ <https://www.epa.gov/sites/default/files/2020-08/documents/alt082.pdf>.

⁵¹⁹ EPA-HQ-OAR-2021-0317-2336 and -2428.

requirements for well sites and centralized production facilities are not adequate to ensure that flare control systems are operated efficiently. The commenter was concerned with the proposed alternative initial NHV sampling demonstration. The commenter suggested that 10 days of sampling cannot capture the variability of gas streams at oil and gas facilities, due in part to compositional variability, inert gases, and impurities in gas streams, and that it may not capture the lowest NHV streams, giving the false impression that these facilities are meeting the NHV operating limit when in fact they are not. The commenter also stated that the alternative to continuous monitoring is contradicted by findings the EPA has made regarding the great variability of gas compositions over short periods of time and the resulting dramatic effects on combustion efficiencies.⁵²⁹ The commenter contends that this alternative cannot ensure that flares and other control devices destroy 95 percent of VOCs and methane and that this alternative does not fulfill the requirements of 40 CFR 60.18(d).

Response: The EPA disagrees with the comments that neither continuous monitoring nor the initial NHV sampling demonstration (which the EPA proposed as an alternative to continuous monitoring) is unnecessarily burdensome or its cost unreasonable because the NHV value will always (or is expected to always) be above the NHV values that we proposed and are finalizing in this action. Specifically, we disagree with the commenters' assumption that the NHV value will always (or is expected to always) be above the minimum NHV values. As noted by a commenter, the variability of gas compositions can have a dramatic effect on the combustion efficiency of flares. This is especially true for streams that may contain large amounts of inert materials. Additionally, the EPA does not have data to support the assertion made by the commenter that continuous sampling systems have technological issues with sampling low and intermittent gas streams.

Nevertheless, in response to the comments received, the EPA has reevaluated the proposed alternative initial NHV sampling demonstration to see whether the burden can be reduced without compromising its adequacy. We do not think it is appropriate to allow quarterly sampling or a one-time

sample, as suggested by some commenters, since there is some variability in the streams that are sent to flares and enclosed combustion devices which will likely be missed by not sampling daily. However, we are reducing the number of daily samples associated with the initial NHV sampling demonstration. Specifically, we are finalizing a requirement to conduct twice daily sampling for 14 days, reducing the total number of samples from 240 to 28. However, due to the significant reduction in the initial sampling, we need to confirm that the vent gas NHV remains above the required minimum value. Therefore, we are adding to the NHV demonstration alternative an ongoing compliance demonstration requirement to sample the vent gas to confirm that the NHV remains above the required minimum value. We are requiring three samples to be taken every 5 years. This ongoing demonstration timeline aligns with the timeline for conducting periodic performance tests of enclosed combustion devices, which is required every 5 years, so owners and operators who are using enclosed combustion devices to meet the applicable emission standards in this rule will be able to combine the NHV vent gas sampling with the performance test, which will help to reduce the burden associated with the ongoing compliance demonstration. Additionally, where associated gas from a well affected facility is the only inlet stream to the enclosed combustion device or flare, we are not requiring owners and operators to conduct continuous monitoring of the NHV or the alternative NHV sampling demonstration. In this case, because associated gas is high in methane content and similar in quality to sales grade gas, the NHV of the inlet stream to the enclosed combustion device or flare is considered to be sufficiently above the minimum required NHV for the inlet gas, and sampling is not needed to confirm the NHV of the inlet stream. With the changes discussed above, we believe that the burden of the NHV demonstration alternative in the final rule is much reduced since proposal.

While the EPA agrees with the comment that the variability of gas compositions can have a dramatic effect on the combustion efficiency of flares, the EPA disagrees with the commenter's contention that the alternative initial NHV demonstration is somehow contradicted by the EPA's prior statements in the proposed CAA section 112(d)(6) review for Miscellaneous Organic Chemical Manufacturing (84 FR

69203 (December 17, 2019)). The EPA notes that the great variability of gas compositions over short periods of time and the resulting dramatic effects on combustion efficiencies is especially true for streams that may contain large amounts of inert materials, such as nitrogen padding from storage vessels, which is common in the refining and chemical sectors. However, in general, we do not expect to see those situations in the upstream oil and gas sector, where most vent gas streams consist of high percentages of methane, which has an NHV well above the required minimum flare gas NHV. We also note that, in the preamble for the Miscellaneous Organic Chemical Manufacturing risk and technology review cited by the commenter, the flare discussion focused on flares that burn ethylene oxide and olefins/polyolefins.⁵³⁰ Olefins and polyolefins are more difficult to combust than the small, straight-chain hydrocarbons generally found in the upstream oil and gas sector. Therefore, the EPA does not believe that the alternative provided in the final rule is contradicted by the findings in the Miscellaneous Organic Chemical Manufacturing risk and technology review.

Comment: One commenter⁵³¹ stated that some vent streams from affected facilities could potentially be below the minimum NHV requirement, including compressors in acid gas service or those at enhanced oil recovery facilities. The commenter notes that either situation could have high CO₂ content which would lower the NHV, so operators typically add assist gas or another vent stream with sufficient heating value to facilitate proper control device operation. In these limited situations, the commenter proposed that flow monitoring of the assist gas and vent streams should be allowed as an alternative to the continuous monitoring of NHV.

Response: The EPA disagrees that monitoring assist gas flow rates is an appropriate measure for ensuring proper combustion of inerts, as assist gas does not contain any heating value. Therefore, the introduction of assist gas will further reduce the heating value of the gas, possibly to a point where proper combustion cannot be sustained. Therefore, while monitoring or limiting assist gas is an important part of ensuring proper flare operation, the EPA does not believe that monitoring assist gas on its own can compensate for the drop in vent gas NHV caused by inerts or provide enough information for the

⁵²⁹ The commenter cited to the proposed CAA section 112(d)(6) review for Miscellaneous Organic Chemical Manufacturing. See 84 FR 69203 (December 17, 2019).

⁵³⁰ See 84 FR 69198–69199 (December 17, 2019).

⁵³¹ EPA–HQ–OAR–2021–0317–2428.

owner or operator to ensure that proper combustion is occurring.

The introduction of inerts can greatly affect the NHV of the vent stream sent to a flare. While the EPA agrees that most flare gas streams at upstream oil and gas facilities will have no issue meeting the required minimum NHV on a continuous basis, we are concerned about situations where inerts may be introduced into the vent gas stream. To guard against the possibility of unacceptable flare gas NHV in these situations, we are including as part of the alternative NHV demonstration a requirement that owners and operators consider sources of inerts that may be sent to the flare, and that sampling must occur when the highest percentage of inerts are sent to the flare to ensure that NHV remains above the required minimum. If an owner or operator cannot ensure that the NHV remains above the required minimum due to the introduction of inerts, the owner or operator must continuously monitor the NHV of the vent stream.

5. Assisted Flares

Comment: A commenter⁵³² urged the EPA to require any assisted flares in the oil and gas sector to meet an operating limit for the NHV in the combustion zone (NHVcz), as the EPA has done for flares at refineries and petrochemical sources. The commenter stated that, as the EPA found in its 2014–15 refinery NESHAP rulemaking, many studies have shown that the flare requirements in the general provisions cannot ensure that flares achieve 98 percent destruction efficiency, which is required under the refinery NESHAP.⁵³³ The commenter also referenced an Enforcement Alert⁵³⁴ the EPA distributed regarding flaring violations, in which the Agency recognized that certain needed parameters affecting the efficiency of flares are not captured within the general provisions, including maintaining the appropriate steam-to-vent-gas ratio and ensuring that the NHVcz is high enough to maximize combustion efficiency. The commenter explained that the EPA noted that reliance on the NHV of the vent gas—the parameter that the NSPS and NESHAP general provisions flare requirements use as an indicator of good combustion—ignores any effect of steaming. Therefore, the commenter stated that to incorporate steaming, a NHVcz is calculated to include the

assist steam.⁵³⁵ The commenter stated that because complying with an operating limit for the heating value of the vent gas cannot ensure 95 percent or greater destruction efficiency of VOCs and methane by assisted flares, it is appropriate to update the flare requirements for any assisted flares to ensure proper destruction efficiencies. The commenter stated that the EPA must require owners and operators to comply with an operating limit for NHVcz and must promulgate monitoring requirements to ensure compliance with that limit.

Response: The EPA is aware that some companies are installing air-assisted flares to improve combustion efficiency, reduce smoking incidence of flares, and facilitate operation when inerts are added to the vent gas stream.⁵³⁶ We are still not aware of a prevalence of steam-assisted flares in this sector, but it is possible to over-assist an air-assisted flare. Therefore, in the final NSPS OOOOb, we are adding requirements to ensure that these flares are operated in a manner that will ensure good combustion efficiency, by adding operating parameters for NHVcz and the NHV dilution parameter (NHVdil). Specifically, the final rule includes the operating parameter values of 270 Btu/scf for NHVcz and 22 Btu/sqft for NHVdil that the EPA established for the petroleum refineries sector (40 CFR part 63, subpart CC).⁵³⁷ We recognize that these limits were intended to demonstrate compliance with a destruction efficiency of 98 percent and therefore are conservatively high for demonstrating compliance with the applicable standards in NSPS OOOOb. We have added provisions similar to those in 40 CFR 63.670(j)(6) which allow reduced monitoring for owners and operators with flare gas streams that have a consistent composition or a fixed minimum NHV. As stated above, we expect many flares in the upstream oil and gas sector to burn high NHV streams and anticipate that most owners and operators would be able to use these provisions. Additionally, for air-assisted flares, we have added provisions that allow a demonstration that based on the highest fixed or highest air-assist rate used, the device will meet or exceed NHVdil in

lieu of continuously monitoring the air-assist rate.

We are not adding these requirements to the final EG OOOOc because we are concerned about the ability of existing sites to retrofit flares in order to meet these requirements. While we do expect that most owners and operators will be able to demonstrate compliance through flare assessments, those who cannot demonstrate compliance through an assessment will have to conduct continuous sampling of flare vent streams and flowrate monitoring of both the flare vent stream and the air assist stream. These accommodations can easily be made for a new flare. For an existing flare at an existing site, these retrofits require taking the flare out of service and may require adding ports to set up these monitoring systems. Additionally, there is no guarantee that ports can be placed at an appropriate location. Without additional information on assisted flares at existing sites and the ability of owners and operators to retrofit these flares, we are reluctant to place these requirements on existing sources, and as such, we are not adding these requirements to the final EG OOOOc.

6. Alternative Flare Monitoring

Comment: A commenter⁵³⁸ recommended that the EPA consider adding an alternative approach for monitoring flares that is more cost-effective and will achieve the same objective. The commenter pointed out that there have been significant advancements in the field of flare performance monitoring technology in recent years, including the Video Imaging Spectral Radiometry (VISR) technology which has been developed to remotely and directly monitor flare combustion efficiency and the Simplified VISR technology which has been developed to remotely monitor NHVcz for steam-assisted flares and NHVdil for air-assisted flares.⁵³⁹ The commenter noted that in November 2022 the EPA funded additional testing with focus on the Simplified VISR technology on both steam-assisted and air-assisted flares at the John Zink flare testing facility in Tulsa, Oklahoma. The commenter summarized the test results in exhibit 3 of their letter and stated that, based on these results, Simplified VISR technology can be easily deployed for a short-term study or long-term continuous monitoring of NHVcz for steam-assisted flares or NHVdil for air-assisted flares at a cost comparable to an OGI camera. The commenter requested

⁵³⁵ EPA (U.S. Environmental Protection Agency). 2012. *Parameters for Properly Designed and Operated Flares*. Prepared for U.S. Environmental Protection Agency, Office of Air Quality Planning and Standards, Research Triangle Park, NC. April 2012. Available at: <https://www3.epa.gov/airtoxics/flare/2012flaretechreport.pdf>. See p. 3–32.

⁵³⁶ See, e.g., EPA–HQ–OAR–2021–0317–2409 and –2428.

⁵³⁷ See discussion in EPA–HQ–OAR–2010–0682–0206.

⁵³⁸ EPA–HQ–OAR–2021–0317–2457.

⁵³⁹ See EPA–HQ–OAR–2021–0317–0604.

⁵³² EPA–HQ–OAR–2021–0317–2362.

⁵³³ The commenter cited 79 FR 36905 and 80 FR 75189.

⁵³⁴ The commenter cited to EPA, EPA Enforcement Targets Flaring Efficiency Violations, Enforcement Alert (August 2012).

that the EPA allow operators to use the Simplified VISR method to demonstrate compliance and give operators a choice between a calorimeter and the Simplified VISR. Additionally, if an operator chooses to do the 10-day initial NHV sampling demonstration instead of continuous monitoring of NHV, the Simplified VISR device could be installed to monitor the flare for 10 days and could operate autonomously and continuously—a significant advantage over manually collecting 200 hourly samples.

To facilitate the described alternative approach, the commenter stated, the flare NHV standard needs to be supplemented. The current NHV limit is based on the heat content in the gas stream that is fed to the flare, but the Simplified VISR measures NHVcz, which the commenter stated represents a better surrogate parameter for flare performance than vent gas NHV. To facilitate the Simplified VISR as an alternative to the proposed NHV limit, the commenter recommended that the final rule allow the operator to comply with the NHVcz and NHVdil limits promulgated in other rules.⁵⁴⁰ The commenter points out that these standards correspond to a combustion efficiency of 96.5 percent and a destruction efficiency of 98 percent, which is higher than the control efficiency required in the December 2022 Supplemental Proposal, representing a 60 percent methane emissions reduction (from 5 percent of the flared process stream down to 2 percent).

Response: The EPA notes that it has been reviewing the development of VISR to monitor flare combustion efficiency for several years. While we are not including it as an alternative in the final rule, as we have not yet developed a standard method for its use, the final rule provides a pathway to allow for the use of VISR, Simplified VISR, or other similar technology. In this pathway, an owner or operator could request an alternative test method to use a technology such as VISR that continuously monitors combustion efficiency or a technology such as Simplified VISR that continuously monitors NHVcz and NHVdil. The approval of such a request may be site-specific or may instead become broadly applicable, approved for a class of combustion devices, and listed on the EPA's website as an alternative test method.

⁵⁴⁰ The referenced limits are 270 Btu/scf NHVcz for steam-assisted flares and of 22 Btu/sqft NHVdil for air-assisted flares. These standards were first promulgated in 40 CFR part 60, subpart CC, at 40 CFR 63.670.

To facilitate the pathway for potentially allowing these alternatives, the EPA is finalizing limits of 270 Btu/scf for NHVcz and 22 Btu/sqft for NHVdil. Destruction efficiency is a measure of how much of the hydrocarbon is destroyed, and combustion efficiency is a measure of how much of the hydrocarbon burns completely to yield CO₂ and water vapor. As such, combustion efficiency will always be less than or equal to the destruction efficiency. In the EPA's report⁵⁴¹ on the development of parameters for properly operated flares, we stated that the relationship between destruction and combustion efficiency is not constant and changes with different compounds, but that we considered that a flare with a combustion efficiency of 96.5 percent achieved a destruction efficiency of 98 percent. We are uncertain if the relationship continues to hold at the same level as combustion efficiency continues to decrease. Therefore, in this final rule, which includes 95 percent emissions reduction standards, we are taking a conservative approach. If an owner or operator uses an alternative test method, such as VISR, to demonstrate compliance with the emissions reduction standards for a combustion control device and uses a test method that continuously monitors the combustion efficiency, we are requiring that the combustion device used to meet such standard have at least 95 percent combustion efficiency, as this will ensure a destruction efficiency of at least 95 percent.

In this final rule, owners and operators approved for an alternative test method that uses a technology that continuously monitors combustion efficiency or NHVcz and NHVdil would not be required to monitor flare vent gas flow rate or vent gas NHV. If the alternative test method uses a technology that continuously monitors combustion efficiency, the owner or operator would not be required to continuously monitor for the presence of a pilot flame or have an alert to the control room for the pilot flame. If the alternative test method uses a technology that can identify periods of visible emissions, the owner or operator would not be required to perform monthly EPA Method 22 observations. The EPA has also added a pathway to use an alternative test method to

⁵⁴¹ EPA (U.S. Environmental Protection Agency). 2012. *Parameters for Properly Designed and Operated Flares*. Prepared for U.S. Environmental Protection Agency, Office of Air Quality Planning and Standards, Research Triangle Park, NC. April 2012. Available at: <https://www3.epa.gov/airtoxics/flare/2012flaretechreport.pdf>.

demonstrate continuous compliance with 95 percent combustion efficiency as part of the NHV initial sampling demonstration. In lieu of conducting vent gas NHV sampling during the initial demonstration period, the owner or operator would demonstrate that the combustion control device continuously achieves at least 95 percent combustion control, thus demonstrating that the heating values of the streams sent to the flare are consistently above the minimum level necessary to achieve proper combustion.

7. Other Changes to Control Device Requirements

Additionally, the EPA has made a number of clarifications and minor adjustments to the regulatory text in response to comments received:

- Revised 40 CFR 60.5412b(a)(1)(ii) and (f)(1)(vii)(D)(1) to allow owners and operators to set the minimum temperature limit for combustion devices based on operation during the performance test.

- Revised 40 CFR 60.5412b(a)(1)(viii), 60.5412b(a)(3)(viii), 60.5413b(e)(2), 60.5415b(f)(1)(vii)(A)(1), and 60.5417b(d)(8)(i) to add a requirement that an alert be sent to the control room when a pilot flame is no longer lit.

- Revised 40 CFR 60.5412b(a)(1)(ix), 60.5413b(e)(3), 60.5415b(f)(1)(vii)(A)(2), and 60.5417b(d)(8)(v) to allow the duration of the visible emissions observation to be less than 15 minutes if the observer sees visible emissions for at least 1 minute prior to the end of the 15-minute period.

- Revised 40 CFR 60.5412b(a)(3)(vi) and 60.5417b(d)(8)(iv) and added 40 CFR 60.5415b(f)(1)(vii)(A)(6) to clarify that the minimum flow rate requirement applies to both enclosed combustion devices and flares.

- Revised 40 CFR 60.5413b(b)(5)(ii) to allow control devices to be tested 30 days after returning to service if the control device is not operational at the time that a performance test is due.

- Revised 40 CFR 60.5413b(b)(5)(ii) to remove the conflict with 40 CFR 60.5413b(a) as to whether enclosed combustion devices must be periodically tested.

- Revised 40 CFR 60.5413b(d)(11)(iii) to indicate that when the manufacturer meets the testing requirements outlined for an enclosed combustion device, the control device will meet the requirement for 95.0 percent destruction of both VOC and methane.

- Revised 40 CFR 60.5413b(d)(12) to update submittal addresses.

- Revised 40 CFR 60.5413b(e), 60.5417b(d)(7), and 60.5417b(g)(6) to align the monitoring requirements for

all enclosed combustion devices, regardless of whether they are tested by the manufacturer or the owner or operator.

- Revised 40 CFR 60.5417b(c) to clarify that monitoring systems that check for the presence of a pilot flame must record a reading at least once every 5 minutes and to clarify how to average monitored parameters.
- Revised 40 CFR 60.5417b(c)(2) through (4) to change site-specific monitoring plan to a company-defined area monitoring plan, to align the terminology with the terminology used for fugitive emissions monitoring.
- Revised 40 CFR 60.5417b(d)(8)(ii) to allow owners and operators the option to use gas chromatographs, mass spectrometers, and grab sampling systems to monitor NHV.
- Revised 40 CFR 60.5417b(d)(8)(ii) to exempt operators from conducting monitoring of NHV for associated gas routed to an enclosed combustion device or flare if the device or flare is receiving only associated gas (as defined in 40 CFR 60.5430b).
- Revised 40 CFR 60.5417b(d)(8)(iv) to change the required flow meter accuracy requirement from 2 percent to 10 percent in order to allow owners and operators additional metering device options and to reduce burden, considering the large range of flows that may be encountered in some control devices.
- Revised 40 CFR 60.5417b(d)(8)(iv) to clarify “line pressure” to “inlet line pressure.”
- Revised 40 CFR 60.5417b(d)(8)(iv) to change the terminology “backpressure preventer” to backpressure regulator valve and to add continuing operational and maintenance requirements for the backpressure regulator valve.
- Deleted 40 CFR 60.5417b(e)(2) in order to change the averaging time for gas flow rate from 1 hour to 3 hours to align with other operating parameters.
- Clarified the requirements for carbon adsorption systems in 40 CFR 60.5417b(f)(1).

I. Reciprocating Compressors

In section X.I of this document, the final NSPS OOOOb and EG OOOOc requirements for reciprocating compressors are summarized. The BSER analysis is unchanged from what was presented in the November 2021 Proposal (see 86 FR 63214–20, section XII.E. Proposed Standards for Reciprocating Compressors). However, significant comments were received on the December 2022 Supplemental Proposal on the following topics: (1) the EPA’s proposal to format the

performance-based volumetric flow rate standard of performance as a numeric standard, (2) scheduled-based packing replacement approach, (3) need to clarify that the standard is on a per-cylinder basis, (4) request that the EPA allow the alternative compliance option of routing to a control device in addition to routing to the process, and (5) the EPA’s extension of requirements to reciprocating compressors located at centralized production facilities. For each of these topics, a summary of the proposed rule (where relevant), the comments, the EPA responses, and changes made in the final rule (if applicable), are discussed here. These comments and the EPA’s responses to these comments generally apply to the standards proposed in both the NSPS OOOOb and EG OOOOc as the standards proposed under the NSPS OOOOb and EG OOOOc were the same. The EPA’s full response to comments on the November 2021 Proposal and December 2022 Supplemental Proposal, including any comments not discussed in this preamble, can be found in the EPA’s RTC document for the final rule.⁵⁴²

1. Numeric Standard Versus Work Practice Standard

In reconsidering the BSER determination and standards for reciprocating compressors proposed in November 2021, the EPA recognized that it is feasible to prescribe a standard of performance, rather than a work practice standard,⁵⁴³ for reciprocating compressors. Accordingly, the EPA proposed a numeric emissions limit requirement in the December 2022 Supplemental Proposal. The major difference between that proposed standard and what the EPA proposed in November 2021 was that under the supplemental proposal, owners and operators would be required to maintain emissions at or below the emissions

⁵⁴² *Standards of Performance for New, Reconstructed, and Modified Sources and Emissions Guidelines for Existing Sources: Oil and Natural Gas Sector Climate Review. Response to Public Comments on the November 2021 Proposed Rule and the December 2022 Supplemental Proposed Rule* (86 FR 63110, November 15, 2021; 87 FR 74702, December 6, 2022).

⁵⁴³ Under CAA section 111(h)(1), work practice standards are appropriate only where “it is not feasible to prescribe or enforce a standard of performance.” CAA section 111(h)(2) defines such infeasibility as “any situation in which the Administrator determines that (A) a pollutant or pollutants cannot be emitted through a conveyance designed and constructed to emit or capture such pollutant, or that any requirement for, or use of, such a conveyance would be inconsistent with any Federal, state, or local law, or (B) the application of measurement methodology to a particular class of sources is not practicable due to technological or economic limitations.”

limit (emissions flow rate of 2 scfm) whereas under the November 2021 Proposal, owners or operators would have been required to replace rod packing only after discovering an exceedance of 2 scfm. The BSER was therefore proposed to be the replacement of the rod packing and/or other necessary repair and maintenance activities to maintain emissions at or below 2 scfm.

Comment: The EPA received several comments from industry⁵⁴⁴ that asserted that a numeric emissions standard in lieu of a work practice standard is unsupported and unworkable. One commenter⁵⁴⁵ stated that in the November 2021 Proposal, the EPA described a work practice standard that would require yearly monitoring and replacement of the rod packing when the measured emissions exceed 2 scfm. The commenter noted that the EPA cited the Natural Gas STAR document in the November 2021 Proposal that described a work practice approach for rod packing replacement. The commenter added that the work practice approach, including a 2 scfm threshold for triggering rod packing replacement, was further demonstrated at the EPA’s November 2019 Natural Gas STAR and Methane Challenge Workshop.⁵⁴⁶ The commenter added that the California regulation⁵⁴⁷ cited by the EPA in the December 2022 Supplemental Proposal TSD is also a work practice standard with a 2 scfm threshold. The commenter stated that the December 2022 Supplemental Background TSD does not include any information to support an emissions standard rather than a work practice—and the November 2021 Proposal TSD⁵⁴⁸ envisioned a work practice standard. Thus, the commenter stated that if the EPA intended to propose an emissions limitation standard, the EPA gave no justification for, or analysis of, the change, which the commenter believed is arbitrary and capricious. The

⁵⁴⁴ EPA–HQ–OAR–2021–0317–2305, –2326, –2399, –2428, and –2483.

⁵⁴⁵ EPA–HQ–OAR–2021–0317–2483.

⁵⁴⁶ “DTE Energy Rod Packing Evaluation and Replacement Program,” U.S. EPA 2019 Natural Gas STAR & Methane Challenge Workshop (November 2019).

⁵⁴⁷ CARB. “[Regulation for Greenhouse Gas Emission Standards for Crude Oil and Natural Gas Facilities.]” Oil and Gas Final Regulation Order (*ca.gov*).

⁵⁴⁸ EPA, Oil and Natural Gas Sector: Emission Standards for New, Reconstructed, and Modified Sources and Emissions Guidelines for Existing Sources: Oil and Natural Gas Sector Climate Review, Background TSD for the Proposed New Source Performance Standards (NSPS) and Emissions Guidelines (EG) (October 2021), Document ID No.–HQ–OAR–2021–0317–0166 (hereinafter “2021 Background TSD”).

commenter believed that based on the two TSDs, it appeared that the EPA intended to propose a work practice standard that triggers rod packing maintenance when the threshold is exceeded. The commenter expressed that the extensive and case-by-case nature of rod packing replacement makes it particularly unsuitable for an emissions limitation standard.

Several commenters⁵⁴⁹ expressed concern that, as an emissions standard, the proposed rod packing requirements are unworkable. They explained that operators would be forced to decide between continuing to operate out of compliance until a maintenance shutdown can be scheduled or shutting down the compressor immediately to conduct the repair and venting or flaring gas that can no longer be compressed and transported during the unscheduled shutdown. The commenters added that a forced shutdown would likely result in significantly more emissions than continuing to operate until the next scheduled maintenance shutdown. For systems that are at capacity, shifting the incoming gas to another station is not a feasible or reliable option, resulting in additional flaring and venting, which is magnified given the time it takes to have producers shut in wells. According to one of the commenters,⁵⁵⁰ the December 2022 Supplemental Proposal made an incorrect assumption that the gas can simply be rerouted to other natural gas compression facilities, but the commenter explained that often that is not a possibility as piping is not in place to bypass a facility, or there may not be an alternative facility available. Another commenter⁵⁵¹ added that while it is true that flow can be measured, it is not technically or economically practicable to install measurement systems that would assure compliance with a numeric emissions limitation. See CAA section 111(h)(2)(B).

A couple of commenters⁵⁵² suggested that under a work practice framework (which they state to be the only supported option), companies be required to complete a corrective action within 720 hours of operation (equivalent to 30 days) and allow for delay of repair, similar to that for leak monitoring programs, of up to 2 years if repair goes beyond the replacement of rod packing. The commenters noted that exceeding the vent rate threshold after the time for corrective action would be a deviation, but exceeding the vent rate

within the time allotted to correct would not.

One commenter⁵⁵³ stated that the EPA proposed to establish the 2 scfm flowrate as a not-to-exceed standard of performance, such that a violation occurs if flow rate exceeds that value (87 FR 74797). In doing so, the commenter suggested, the EPA fundamentally misconstrued the manufacturers' recommendations (on which the flow rate is based). In practice, the commenter explained, exceeding a manufacturer-recommended flow rate is an indication that a repair should be made. Exceeding that rate does not necessarily compromise operability of the unit and, in fact, the values are selected to allow continued operation for the period necessary to arrange for needed repairs to be made. According to the commenter, the EPA without explanation proposed to transform what in practice constitutes an action level into a regulatory cap that cannot be exceeded without the prospect of incurring a violation. The commenter argued that the EPA's proposal is at odds with the facts and is an unreasonable reinterpretation of standard maintenance practices.

The commenter⁵⁵⁴ argued that, if the EPA is intent on setting a numeric standard of performance, the value must be well above the 2 scfm that the EPA believes to be the standard manufacturer recommendations. They asserted that the value must accommodate operations for a reasonable and potentially significant period of time that may be needed to accomplish needed repairs. If the EPA takes this path, the commenter contended that a reproposal would be necessary so that commenters would know the newly proposed value, understand the EPA's rationale, and have an opportunity to submit comments on the record.

Response: The EPA acknowledges that the record for the 2 scfm performance volumetric flow rate standard supports a work practice standard and not a numeric standard. The EPA has determined that, for reciprocating compressors, the application of a measurement methodology to reciprocating compressors is not always practicable due to technological or economic limitations. It is not practicable here for an exceedance of the 2 scfm per cylinder volumetric flow rate to be a violation when the annual performance-based flow rate reflects whether there are performance issues with the rod

packing that need to be addressed in order to take action to minimize the emissions/leak. This is similar to the basis and monitoring established for fugitive emissions component requirements, where a leak based on periodic monitoring triggers requirements to minimize the emissions/leak.

In the final rule, therefore, the 2 scfm performance-based volumetric flow rate standard will be implemented as a work practice standard and not as a numeric limit where an exceedance would be considered a violation. As such, the volumetric flow rate of 2 scfm is an action level that, if exceeded, triggers the action of repairing or replacing the rod packing and is not a numerical limit. Specifically, the final rule for reducing GHGs and VOC from new reciprocating compressors requires repair or replacement of the rod packing where, based on the required monitoring, the performance-based volumetric flow rate standard is exceeded. If the volumetric emissions measurement of the reciprocating compressor rod packing has a flow rate greater than 2 scfm (in operating or standby pressurized mode) or a combined rod packing flow rate greater than the number of compressor cylinders multiplied by 2 scfm, an owner or operator must repair or replace the reciprocating compressor rod packing within 30 calendar days after the date of the volumetric emissions measurement. Delay-of-repair provisions under a work practice standard appropriately recognize that the unit must be shut down to effect any such repair and replacement and that parts availability and supply chain disruptions may be relevant to how quickly the repair or replacement can be made. As such, the final rule allows for a delay of repair if the repair or replacement would require a vent blowdown, or it would otherwise be infeasible or unsafe, until the next process unit shutdown—specifically, if the repair or replacement (1) is technically infeasible, (2) would require a vent blowdown, (3) would require a process unit or facility shutdown, (4) needs to be delayed because parts or materials are unavailable, or (5) would be unsafe to repair during operation of the unit. In cases where there is a need for delay of repair, the repair must be completed during the next scheduled process unit or facility shutdown for maintenance, after a scheduled vent blowdown, or within 2 years, whichever is earliest.

⁵⁴⁹ EPA-HQ-OAR-2021-0317-2305, -2399, and -2428.

⁵⁵⁰ EPA-HQ-OAR-2021-0317-2305.

⁵⁵¹ EPA-HQ-OAR-2021-0317-2428.

⁵⁵² EPA-HQ-OAR-2021-0317-2305 and -2399.

⁵⁵³ EPA-HQ-OAR-2021-0317-2428.

⁵⁵⁴ EPA-HQ-OAR-2021-0317-2428.

2. Rod Packing Changeout Schedule-Based Approach

Comment: Several commenters⁵⁵⁵ expressed concern over the EPA's changing in the proposed NSPS OOOOb and EG OOOOc the requirements that the commenters have been meeting under NSPS OOOOa to replace rod packing on a fixed schedule. The commenters noted that given the uncertainties of the assumptions underlying the BSER evaluations for the two options (the rod packing changeout schedule-based approach and monitoring limit approach) and given that the cost effectiveness values of the two options are very close, they urged the EPA to provide flexibility to affected facilities by adopting both standards as BSER alternatives with the operator selecting their preferred approach.

According to one commenter,⁵⁵⁶ retaining the schedule-based approach is warranted because that compliance option has been implemented not only at NSPS OOOOa facilities but also through state regulations and voluntary actions by companies. The commenter added that the prescribed maintenance schedule is also an EPA-approved best management practice for the voluntary Methane Challenge program. Due to these EPA decisions, the commenter reported, many companies have “built out” reciprocating compressors rod packing maintenance programs using scheduled maintenance, including existing compressors not subject to the Federal mandate or state rules. The commenter expressed that it is critical that these existing and successful company programs not be supplanted by different requirements in NSPS OOOOb and EG OOOOc.

Several commenters noted specific suggestions with respect to a fixed schedule:

- Several commenters⁵⁵⁷ requested that the EPA allow rod packing replacement every 8,760 operating hours.
- One commenter⁵⁵⁸ requested that the EPA allow replacement annually or 8,760 hours (whichever comes first), which is similar in approach but more frequent than the current requirements in NSPS OOOO and NSPS OOOOa.
- Another commenter⁵⁵⁹ requested retaining the NSPS OOOOa approach, requiring the replacement of rod

packing every 3 years or 26,000 hours of operation (if operating hours are monitored).

Several commenters⁵⁶⁰ requested that the EPA specify that where operators choose to replace rod packing on a fixed schedule, they are not required to measure volumetric flow rates.

Response: The contention by commenters that requiring the performance-based volumetric flow rate monitoring would result in owners or operators having to do more rod packing changeouts on reciprocating compressors and/or would lead to an increase in baseline maintenance/piston rod replacement to ensure proper operation of the compressor further supports requiring the performance-based volumetric flow rate monitoring standard over a fixed-schedule rod packing changeout every 26,000 hours to mitigate emissions. This is also consistent with the EPA's BSER determination that greater and more-efficient emissions reductions would be achieved by implementing an annual performance-based 2 scfm volumetric flow rate monitoring standard. For these reasons, the EPA is not including the 26,000-hour, fixed-schedule rod packing replacement as an alternative option to the condition-based 2 scfm volumetric flow rate monitoring option. However, under the final rule, the EPA has clarified that an owner or operator would be allowed to replace rod packing on or before 8,760 hours of operation after last rod packing replacement or monitoring and forgo the need to conduct the required performance-based volumetric flow rate monitoring. The final rule also specifies that owners or operators are allowed to forgo volumetric flow rate measurements if they replace the rod packing at or before 8,760 hours of operation after the last rod packing replacement or flow rate measurement.

The final rule has also been revised to state that the first volumetric flow rate measurements from a reciprocating compressor affected facility are to be conducted at or before 8,760 hours of operation after the effective date of the final rule (*i.e.*, 60 days after publication of the final rule in the **Federal Register**), or at or before 8,760 hours of operation after the last rod packing replacement, or at or before 8,760 hours of operation after startup, whichever is later.

Subsequent volumetric flow rate measurements from your reciprocating compressor are to be conducted at or before 8,760 hours of operation after the previous measurement that

demonstrates compliance with the 2 scfm volumetric flow rate, or at or before 8,760 hours of operation after the last rod packing replacement, whichever is later. As an alternative to conducting required volumetric flow rate measurements, the final rule allows an owner or operator the option to comply by replacing the rod packing at or before 8,760 hours of operation after the effective date of the final rule, at or before 8,760 hours of operation after the previous flow rate measurement, or at or before 8,760 hours of operation after the date of the most recent compressor rod packing replacement, whichever is later.

3. Clarification That the Standard Is Based on a Per-Cylinder Basis

Comment: Several commenters⁵⁶¹ requested clarification that the volumetric standard applies to each rod packing (or throw) or set of packing and not to the entire compressor and that the rule text clearly addresses manifolded vents on a combined basis. The commenters cite the precedent set by the CARB where reciprocating compressors in California are restricted to 2 scfm per rod packing, and not per compressor, as set forth in 17 CCR section 95668(c)(4)(D), Greenhouse Gas Emission Standards for Crude Oil and Natural Gas Facilities (allowing for “a combined rod packing or seal emission flow rate greater than the number of compression cylinders multiplied by two (2) scfm”) which states:

(6) with a rod packing or seal with a measured emission flow rate greater than two (2) standard cubic feet per minute (scfm), or a combined rod packing or seal emission flow rate greater than the number of compression cylinders multiplied by two (2) scfm.

These commenters generally stated that this approach makes sense and is consistent with the proposed BSER from the November 2021 Proposal. In addition, the EPA based its proposal to measure the flow rate of each cylinder on volumetric emission factors used in the 1996 EPA/GRI report quantifying methane emissions from the U.S. natural gas industry—which the EPA notes are per cylinder. The commenters elaborated on why they believed that this was the EPA's intent and several commenters provided in-line regulatory text changes where they believed the clarification was needed.

Response: The EPA agrees that the basis and intent of the standard is that it be applied on a per-cylinder basis and that clarity was needed in both the

⁵⁵⁵ EPA-HQ-OAR-2021-0317-2227, -2258, -2282, -2298, -2326, -2366, -2399, -2428, and -2483.

⁵⁵⁶ EPA-HQ-OAR-2021-0317-2366.

⁵⁵⁷ EPA-HQ-OAR-2021-0317-2258, -2298, and -2326.

⁵⁵⁸ EPA-HQ-OAR-2021-0317-2428.

⁵⁵⁹ EPA-HQ-OAR-2021-0317-2366.

⁵⁶⁰ EPA-HQ-OAR-2021-0317-2227, -2298, -2326, -2399, and -2428.

⁵⁶¹ EPA-HQ-OAR-2021-0317-2258, -2282, -2305, -2326, -2366, -2391, -2399, -2428, and -2483.

NSPS OOOOb and EG OOOOc regulatory text. The final rule regulatory text has been revised to make this clear as suggested by the commenters. Specifically, clarifying changes have been made to: 40 CFR 60.5385b, paragraphs (a) through (c) of NSPS OOOOb; and 40 CFR 60.5393c, paragraphs (a) through (c) of EG OOOOc.

4. Routing to Process or Control Device

In the December 2022 Supplemental Proposal, the EPA proposed to allow an alternative reciprocating compliance option of routing rod packing emissions to a process via a CVS. Several commenters⁵⁶² requested that they also have the option to use proven add-on controls, such as an existing combustor or flare, in addition to routing to a process. A commenter explained that such options may be key for existing units and units that are modified or reconstructed.

Comment: A few commenters⁵⁶³ provided several reasons for why it may not always be feasible to route rod packing vents back to the process:

- Depending on the pressure differential between nearly ambient rod packing vents and pressurized piping, substantial horsepower may be required to achieve capture.
- Recompression designs require substantial horsepower and could require gas engines of variable horsepower to achieve the recompression, negating some of the emissions reductions this rule seeks to achieve.
- Currently available rod packing capture systems attempted by Williams and others in the industry have performed poorly or are ineffective in certain applications or configurations.
- Rod packing vents are essentially at ambient pressure, creating a situation where oxygen (O₂) could be introduced into the process gas, leading to safety concerns.
- The gas quality in the rod packing vents may not be compatible with the only technically feasible location in the process, based on pressure differentials, for the gas to be routed. For example, if the gas in the compressor is sour gas, but the only technically feasible place for the gas to be absorbed in the process is the fuel gas system, the sour gas is often not a good candidate for fuel gas use due to the detrimental effect on components.

⁵⁶² EPA-HQ-OAR-2021-0317-2258, -2305, -2399, and -2428.

⁵⁶³ EPA-HQ-OAR-2021-0317-2305, -2399, and -2428.

According to one commenter,⁵⁶⁴ currently available rod packing capture systems that have been attempted by the commenter and their members have not performed as intended and, in some applications, have not worked at all. They explained that even if these systems were as effective as advertised, timing is a significant concern as the supply is not currently available to meet demand. The commenter recommended that where rod packing vents are routed to a control device, the EPA could require that the flow be measured every 26,000 hours of operation. The commenter noted that this would ensure that rod packing is appropriately maintained while overall emissions are greatly reduced.

Another commenter⁵⁶⁵ provided that the incremental benefit achieved between monitoring and subsequent repair (if applicable) versus capturing and venting to a control device that achieves 95 percent destruction efficiency has not been substantiated by the EPA within its BSER analysis. This, according to the commenter, is especially true for any compressor that already is designed and configured to route rod packing emissions to a flare or other combustion device.

Response: The EPA evaluated allowing the alternative option of routing to a control device that achieves 95 percent control of emissions and has determined that it would be acceptable as an alternative control option. The volumetric 2 scfm performance-based volumetric flow rate standard is estimated to reduce VOC and methane emissions by approximately 92 percent, and a flow rate of 40 scfm reduced by 95 percent would meet a 2 scfm flow rate. As a result, we have concluded that allowing for routing to a control device achieving a 95 percent reduction in VOC and methane emissions has merit and would provide equivalent or better emissions reduction compared to BSER. Accordingly, we have included this measure as an alternative option for compliance in the final rule.

5. Applicability of Requirements to Compressors Located at Centralized Production Facilities

The EPA proposed (86 FR 63184–85, November 15, 2021) to define centralized production facilities separately from well sites because the numbers and sizes of equipment, particularly reciprocating and centrifugal compressors, are larger than for standalone well sites, which would not be included in the proposed

definition of “centralized production facilities.” In the 2016 NSPS OOOOa, the EPA exempted reciprocating and centrifugal compressors located at well sites from the applicable compressor standards. Reciprocating compressors that are located at well sites are not affected facilities under the 2016 NSPS OOOOa. The EPA previously excluded them because the EPA found the cost of control to be unreasonable. 81 FR 35878. However, we believed the definition of “well site” in NSPS OOOOa may have caused confusion regarding whether reciprocating compressors located at centralized production facilities were also exempt from the standards, which was not our intent.

To clarify our intent, we proposed to define centralized production facility as follows in the December 2022 Supplemental Proposal:

Centralized production facility means one or more storage vessels and all equipment at a single surface site used to gather, for the purpose of sale or processing to sell, crude oil, condensate, produced water, or intermediate hydrocarbon liquid from one or more offsite natural gas or oil production wells. This equipment includes, but is not limited to, equipment used for storage, separation, treating, dehydration, artificial lift, combustion, compression, pumping, metering, monitoring, and flowline. Process vessels and process tanks are not considered storage vessels or storage tanks. A centralized production facility is located upstream of the natural gas processing plant or the crude oil pipeline breakout station and is a part of producing operations.

Additionally, we proposed to define the affected facility as:

(c) Each reciprocating compressor affected facility, which is a single reciprocating compressor. A reciprocating compressor located at a well site is not an affected facility under this subpart. A reciprocating compressor located at a centralized production facility is an affected facility under this subpart.

For purposes of analyses, we proposed to determine that it was appropriate to apply the same emission factors to reciprocating compressors located at centralized production facilities as those used for reciprocating compressors at gathering and boosting compressor stations. Given the results of that analysis, the EPA proposed to apply the proposed NSPS OOOOb requirements to reciprocating compressors located at centralized production facilities. At that time, the EPA proposed a new definition for centralized production facilities to distinguish compressors at standalone well sites where the EPA has determined that the standard should not apply.

⁵⁶⁴ EPA-HQ-OAR-2021-0317-2399.

⁵⁶⁵ EPA-HQ-OAR-2021-0317-2428.

Comment: One commenter⁵⁶⁶ requested that the EPA clarify the applicability of compressor standards to well sites. The commenter stated that the definition proposed for “centralized production facility” may extend applicability to compressors located at well sites, which have historically been exempt from the compressor standards. The commenter noted that the EPA had not updated its cost analyses with new information with respect to well sites and believed that extending applicability to well sites was not the EPA’s intent.

Another commenter⁵⁶⁷ urged the EPA to keep the current compressor exemptions shown in both subparts NSPS OOOO and NSPS OOOOa. The commenter specifically requests that the EPA maintain that each compressor “located at a well site, or an adjacent well site and servicing more than one well site, is not an affected facility.”

Conversely, another commenter⁵⁶⁸ supported the EPA’s proposed definition of a centralized production facility and supported the extension of compressor standards to these sites. While the GHGI does not contain data on the number of compressors in the production segment, the commenter reported that they analyzed data submitted in response to the EPA’s 2016 ICR to assess the number of compressors across different facility types in the production segment. While the ICR data are not a full inventory, the commenter contended that the ICR illustrates that there are a significant number of compressors utilized in the production segment, with most reciprocating compressors located at centralized production facilities.

A couple of commenters⁵⁶⁹ recommended that the EPA continue the exemption of each centrifugal and reciprocating compressor “located at a well site, or an adjacent well site and servicing more than one well site” as provided in both 40 CFR part 60, subpart OOOO, and 40 CFR part 60, subpart OOOOa. The commenters explained that well operators visit and service these wells and associated compressors daily to inspect for proper operation, to inspect for leaks, and to conduct maintenance and repairs activities. Any necessary repairs are implemented as soon as possible to avoid product loss and to maximize profit returns. If the EPA wishes to propose monitoring for well site compressors, the commenters

recommended that the EPA allow the more feasible and cost-effective monthly AVO inspection and documentation, similar to the requirements allowed under 40 CFR 60.5416a.

Some commenters⁵⁷⁰ expressed that applying the proposed monitoring requirements to reciprocating compressors located at “centralized production facilities” may be beneficial in certain operations and where larger oil and gas operators may have the resources and equipment to monitor those emissions. However, they suggested that it should be an option/alternative and not a mandatory requirement, as it may unnecessarily create additional burdens and costs for smaller operators that send production from several marginal/low production wells to a “centralized production facility.” These commenters reported that, for marginal/low production well operators, centralized production facilities may be more cost-efficient than having equipment at each well site and this practice reduces overall the environmental footprint of the operation. The commenters suggested that it would be an unnecessary additional cost on small businesses and that it disincentivizes the use of centralized production facilities in this scenario. The commenters requested that the EPA remove this requirement for marginal/low production wells that send production to centralized production facilities.

Response: Most of these comments were based on the November 2021 Proposal prior to the EPA’s December 2022 Supplemental Proposal definitions cited earlier in this document for a reciprocating compressor affected facility and centralized production facility. The EPA has finalized the December 2022 Supplemental Proposal’s proposed requirements related to the definitions of the reciprocating compressor affected facility and centralized production facility. Some of the commenters suggested that, by extending requirements to apply to centralized production facilities, the EPA was extending requirements to well sites where reciprocating compressors were not previously regulated. That interpretation confirms that clarity was needed. Based on the proposed definition of the reciprocating compressor affected facility, in addition to the proposed definition for centralized production facility as proposed in the December 2022 Supplemental Proposal, we believe that we clarified our intent. That intent is

that reciprocating compressors located at well sites are not subject to requirements. However, reciprocating compressors located at centralized production facilities that consist of equipment at a single surface site used to gather, for the purpose of sale or processing to sell, crude oil, condensate, produced water, or intermediate hydrocarbon liquid from one or more offsite natural gas or oil production wells (including reciprocating compressors) are subject to reciprocating compressor requirements.

In response to the commenters that noted that small operators of marginal/low production wells often send production from several marginal/low production wells to a “centralized production facility” because it is uneconomical to have equipment at each well site, the EPA does not understand why they would no longer be incentivized not to have equipment at each well site. The commenters did not provide sufficient information as to why an owner or operator of reciprocating compressors at centralized production facilities would not continue having reciprocating compressors at centralized production facilities because they would be subject to requirements in lieu of having equipment at each well site.

J. Storage Vessels

In section X.J of this document the final NSPS OOOOb and EG OOOOc requirements for storage vessels are summarized. In the November 2021 Proposal, the EPA proposed that for NSPS OOOOb, a storage vessel affected facility is a tank battery, which can be a single tank, with the potential to emit equal to or greater 6 tpy VOC or 20 tpy methane. The EPA proposed that an owner or operator of a tank battery must determine the potential for VOC and methane emissions using a “generally acceptable model or calculation methodology” that accounts for flashing, working, and breathing losses. The EPA proposed that the determination may take into account requirements under a “legally and practicably enforceable limit” in an operating permit or other requirement established under a Federal, state, local, or Tribal authority and proposed specific elements as to what constitutes a “legally and practicably enforceable limit.” The elements included: a quantitative production limit and quantitative operational limit(s) for the equipment, or quantitative operational limits for the equipment; an averaging time period for the production limit, if a production-based limit is used, that is equal to or less than 30 days; established parametric limits for the

⁵⁶⁶ EPA-HQ-OAR-2021-0317-0808.

⁵⁶⁷ EPA-HQ-OAR-2021-0317-0923.

⁵⁶⁸ EPA-HQ-OAR-2021-0317-0844.

⁵⁶⁹ EPA-HQ-OAR-2021-0317-0465 and -0946.

⁵⁷⁰ EPA-HQ-OAR-2021-0317-0810 and -0814.

production and/or operational limit(s), and where a control device is used to achieve an operational limit, an initial compliance demonstration (*i.e.*, performance test) for the control device that establishes the parametric limits; ongoing monitoring of the parametric limits that demonstrates continuous compliance with the production and/or operational limit(s); and recordkeeping and reporting by the owner or operator that demonstrates continuous compliance with the limit(s). In the November 2021 Proposal, the EPA proposed that a tank battery is a group of storage vessels which are physically adjacent and that receive fluids from the same source or that are manifolded together for liquid or vapor transfer. Regarding BSER, the EPA proposed that storage vessel affected facilities must reduce emissions by 95 percent or greater. The BSER analysis is unchanged from what was presented in the November 2021 Proposal (see 86 FR 63199–201, section XII.B. Proposed Standards for Storage Vessels). The EPA proposed similar requirements for designated facilities under EG OOOOb, which have the potential to emit greater than or equal to 20 tpy methane.

In the November 2021 Proposal, the EPA proposed specific actions that would constitute “modification” of an existing tank battery for purposes of determining whether NSPS OOOOb is triggered (if the potential methane or VOC emissions are determined to be above the applicability threshold). Some of the actions that could trigger modification are actions that occur at the well site, such as refracturing a well or adding a new well that sends these liquids to the tank battery. The EPA did not propose specific provisions for reconstruction in the November 2021 Proposal.

In the December 2022 Supplemental Proposal, the EPA proposed a revised definition of storage vessel affected facility. In response to comments on the November 2021 Proposal, the EPA removed the criterion that the storage vessels in the tank battery are physically adjacent and the criterion that the vapor lines are manifolded together.

In the December 2022 Supplemental Proposal, the EPA retained the same provisions for “legally and practicably enforceable” criteria which were proposed in the November 2021 Proposal. Regarding modification and reconstruction, to address the resultant emissions at a compressor station or onshore natural gas processing plant receiving those liquids, where the emissions have already been accounted for in the permit, in the December 2022 Supplemental Proposal, the EPA

proposed that for compressor stations or onshore natural gas processing plants, the modification trigger occurs when the tank battery receives additional fluids which cumulatively exceed the throughput used in the most recent determination for VOC or methane emissions (*e.g.*, permit) based on the design capacity of such tank battery. In addition, the December 2022 Supplemental Proposal retained the November 2021 criteria that a modification is also triggered when a storage vessel is added to an existing tank battery and/or one or more storage vessels are replaced such that the cumulative storage capacity of the existing tank battery increases. In the December 2022 Supplemental Proposal, the EPA proposed two actions which constitute reconstruction: over half of the storage tanks are replaced in an existing tank battery that consists of more than one storage vessel; or the provisions of 40 CFR 60.15 are met for the existing tank battery that consists of a single storage vessel.

The EPA received significant comments on the definition of legally and practicably enforceable limits, modification, and reconstruction. This section of this preamble presents a summary of those significant comments and the EPA’s response to those comments. These comments and the EPA’s responses to these comments apply to the standards proposed in both the NSPS OOOOb and EG OOOOc. The EPA’s full response to comments on the November 2021 Proposal and December 2022 Supplemental Proposal, including any comments not discussed in this preamble, can be found in the EPA’s RTC document for the final rule.⁵⁷¹

1. Legally and Practicably Enforceable Limits

As explained in the preamble to the November 2021 Proposal (86 FR 63201), from its years of experience of reviewing permits of legally and practicably enforceable limits, the EPA has long been aware that many owners and operators claim that storage vessels are not affected facilities under 40 CFR 60.5365(e) and 40 CFR 60.5365a(e) by alleging that the VOC emissions are less than 6 tpy. Since promulgation of NSPS OOOO in 2012, the EPA has expended extensive resources in enforcement actions nationwide to review permits,

⁵⁷¹ *Standards of Performance for New, Reconstructed, and Modified Sources and Emissions Guidelines for Existing Sources: Oil and Natural Gas Sector Climate Review. Response to Public Comments on the November 2021 Proposed Rule and the December 2022 Supplemental Proposed Rule* (86 FR 63110, November 15, 2021; 87 FR 74702, December 6, 2022).

general permits, and permits-by-rule for storage vessels and found that, in nearly all cases, across nearly 400 storage vessels, these permits or other requirements are not legally and practicably enforceable. In nationwide ongoing enforcement actions, the EPA continues to find permits or permits-by-rule that are not legally and practicably enforceable. The EPA has repeatedly expressed this concern in prior rulemaking actions. See, *e.g.*, 83 FR 52085 and 85 FR 57425. The EPA believes that the new criteria being finalized in this action will help to ensure that storage tank batteries that rely on legally and practicably enforceable limits to claim nonapplicability of NSPS OOOOb or EG OOOOc indeed have potential emissions below the relevant applicability threshold(s).

As discussed in this section, several commenters failed to acknowledge the EPA’s concern, claiming that it does not exist; some commenters insist that the criteria are unnecessary but do not offer any alternative to address the EPA’s concern. The EPA has provided examples of limits that are not legally and practicably enforceable⁵⁷² later in this section and is finalizing the criteria as proposed to ensure that, where an owner and operator is taking into account a legally and practicably enforceable limit in determining the applicability of the storage vessels standards under OOOOb or EG OOOOc, those limits actually limit and maintain potential emissions below the rule’s applicability thresholds under NSPS OOOOb or designated facilities under EG OOOOc. The EPA further notes that including legally and practicably enforceable limits is an option, not a requirement, in determining storage vessel affected facility/designated facility status under NSPS OOOOb and EG OOOOc. The EPA will continue to evaluate the use of permit limits in determining the applicability of the standards for storage vessels pursuant to the criteria finalized in this action to see whether the EPA’s concern is fully addressed. If concerns about the enforceability of the applicability criteria for the storage vessel standards remain upon implementation of the revised regulatory provision, the EPA may initiate further rulemaking in the future.

⁵⁷² See the RTC, volume 2, chapter 13, in EPA–HQ–OAR–2021–0317.

a. Need for a National Rulemaking To Address LPE Across CAA Programs

Comment: Several commenters⁵⁷³ urged the EPA to defer final action on the proposed definition of legally and practicably enforceable limits until such time as the Agency undertakes a national rulemaking. A few of the commenters⁵⁷⁴ pointed out the potential for inconsistencies among the various CAA programs that similarly require legally and practicably enforceable limits to determine applicability (e.g., an effective emissions limit used to avoid major NSR permitting might, at the same time, not be effective for purposes of the NSPS OOOOb and/or EG OOOOc storage vessel standards). One commenter⁵⁷⁵ opined that what constitutes an acceptable and effective “legally and practicably enforceable limit” has been an open question since the mid-1990s, when the prior “Federal enforceability” requirement was remanded or vacated across the EPA’s programs.⁵⁷⁶ Similarly the commenter⁵⁷⁷ believed that these proposed provisions of the NSPS OOOOb and EG OOOOc were driven by a July 2021 report from the EPA Inspector General that criticized the EPA for not responding to these judicial decisions.⁵⁷⁸ The commenter stated that the EPA’s announced plan to establish national rules for effective limits on PTE and to do so in the relative near future⁵⁷⁹ lends strong additional support to the view that the EPA should not address these issues in a premature and piecemeal fashion. Another commenter⁵⁸⁰ stated that a national rulemaking would avoid many potential inconsistencies and uncertainties across CAA programs and would allow the EPA to establish reasonable transition rules so that affected sources and states have time to revise existing emissions limitations as needed to meet the new effectiveness criteria.

Response: The final rule includes “legally and practicably enforceable” criteria specific to oil and gas storage

vessels. The EPA is choosing to add regulatory certainty to describe legally and practicably enforceable emissions limitations to address a common problem that the EPA has observed over the past decade through implementation of NSPS OOOO and OOOOa. Specifically, the EPA has identified problems with permits that states and owners and operators have characterized as legally and practicably enforceable. As discussed in the November 2021 Proposal (see 86 FR 63201) and elaborated in section XI.J.1 of this document, when the EPA has reviewed the limits considered by facilities as legally and practicably enforceable, the limits are often of such a general nature as to be unenforceable or otherwise lack measures to ensure the required emissions reduction. Unless the compliance with the permit limit can be determined, and the permit limit achieves the desired emissions reductions, they are not meaningful requirements. Excerpts of specific permits⁵⁸¹ that the EPA has reviewed and determined to be lacking legally and practicably enforceable limits include:

Permit 1—Applicable Emissions Limitations or Control Measures

- In order to comply with the ton-per-month emissions limit, utilize one or more of the following controls: Use of add-on control (vapor recovery, flare, or equivalent) to control emissions from storage vessels as needed to comply with the annual VOC emissions limitations.

- The permittee accepts a voluntarily limit to restrict the potential VOC emissions from each storage vessel to less than 6 tpy.

In Permit 1, the control device is not specified and the permit terms do not specify a destruction rate efficiency, combustion rate, or availability for a VRU. The provision also does not specify emissions testing, operational parameter monitoring, inspection requirements, or recordkeeping or reporting requirements for the add-on control. Additionally, the terms “voluntarily limit” in the second provision indicate that controlling emissions below 6 tpy of VOCs is not a requirement.

Permit 2—Combustor/Flare Requirements

- All exhaust gas/vapors from the oil storage tanks must be routed to the operating combustor/flare.

- The combustor/flare shall operate with no visible emissions.

- Visual determination of smoke emissions from flares shall be conducted according to 40 CFR 60, appendix A, EPA Method 22.

In Permit 2, a destruction rate efficiency of 95 percent or greater is not specified. There is no testing requirement for the control device, no continuous pilot light monitoring or inspection requirement, no indication of how frequently EPA Method 22 inspections must be conducted, and no recordkeeping or reporting requirements. Both Permit 1 and Permit 2 demonstrate provisions from permits that do not have operational or parametric limits and therefore that the EPA has determined not to be legally and practicably enforceable and thus adequate to ensure that the storage vessels are below the applicability thresholds for the applicable standards.

The EPA disagrees that it should delay establishing the criteria for legally and practicably enforceable limits for purposes of determining storage vessel affected facility/designated facility status under NSPS OOOOb and EG OOOOc until such time as the Agency undertakes a national rulemaking on legally and practicably enforceable limits for other CAA provisions. The criteria in this final rule are unique and specifically tailored toward their intended purpose, which is to ensure that limits that are being taken into account in determining NSPS OOOOb and EG OOOOc applicability do in fact cap the potential emissions of a tank battery below the relevant applicability threshold and are enforceable. There is no reason why the EPA needs to wait to address this long-observed issue with respect to this emission source.

Moreover, general criteria for legally and practicably enforceable limits would not necessarily provide the clarity and certainty that is necessary to ensure that the issue observed in the implementation of NSPS OOOO and OOOOa does not continue in the future in the implementation of NSPS OOOOb and EG OOOOc. Nor would such general criteria be timely, given the NSPS OOOOb standards will apply upon the effective date of this action and states will need to begin developing state plans pursuant to EG OOOOc. Finalizing the criteria now will provide states and sources specificity and certainty as to what the EPA considers legally and practicably enforceable for purposes of determining potential tank battery emissions under NSPS OOOOb or a state or Federal plan implementing EG OOOOc. The EPA believes that this level of specificity and certainty will

⁵⁷³ EPA–HQ–OAR–2021–0317–2298, –2301, –2326, and –2428.

⁵⁷⁴ EPA–HQ–OAR–2021–0317–2428, –2326, and –2298.

⁵⁷⁵ EPA–HQ–OAR–2021–0317–2298.

⁵⁷⁶ *National Mining Ass’n v. EPA*, 59 F.3d 1351 (D.C. Cir. 1995); *Chemical Mfrs. Ass’n v. EPA*, 70 F.3d 637 (D.C. Cir. 1995); *Clean Air Implementation Project v. EPA*, 1996 WL 393118 (D.C. Cir. 1996).

⁵⁷⁷ EPA–HQ–OAR–2021–0317–2428.

⁵⁷⁸ *EPA Should Conduct More Oversight of Synthetic-Minor-Source Permitting to Assure Permits Adhere to EPA Guidance*, Report No. 21–P–0175, memorandum from Sean W. O’Donnell to Joseph Goffman (July 8, 2021) at 17.

⁵⁷⁹ The commenter stated that the EPA intends to issue national guidance by October 2023.

⁵⁸⁰ EPA–HQ–OAR–2021–0317–2326.

⁵⁸¹ The EPA is not able to identify the permittees due to ongoing investigations or enforcement actions.

serve to guide states and sources in establishing permit limits for tank batteries that could be used in determining NSPS OOOOb/EG OOOOc applicability.

b. LPE and Delegated Authorities

Comment: The EPA received multiple comments⁵⁸² regarding the interplay with delegated authorities other than the EPA, such as concern that existing permits may not comply with the criteria proposed by the EPA, how the criteria align with permit-by-rule or permits, and the fact that many existing state permits lack methane limits.

Some commenters⁵⁸³ expressed concern with the proposed definition for the term “legally and practicably enforceable” as it relates to state emissions limits for “storage vessel affected facilities” that limit their potential for VOC emissions below 6 tpy. One commenter⁵⁸⁴ believed that in effect, if the EPA deems applicable state standards not “legally and practically enforceable,” it would disregard the state limits and treat the storage vessels as uncontrolled for purposes of Federal regulation.⁵⁸⁵ The commenter was concerned that this proposal thus has the potential to create substantial friction between the EPA and the states and could result in many more facilities becoming subject to Federal emissions standards.

Another commenter⁵⁸⁶ opined that where a rule contains an emissions threshold under which a given piece of equipment is not subject to the rule’s requirements, it is fair and logical that the equipment be considered outside of rule coverage where emissions controls or limitations are in place to keep emissions below the threshold, even though in an uncontrolled state the equipment is capable of producing emissions above threshold levels. The commenter was concerned that that an owner or operator would be unable to claim the existence of legally and practicably enforceable limits or throughput limitations keeping a storage vessel below the applicability threshold

if they are unable to coordinate with the applicable permit authority to work out specific limits, monitoring requirements, and recordkeeping that will ensure that any permitted emissions limit is achieved. The commenter also pointed out that some programs do not have minor source permitting programs allowing for inclusion of GHG emissions. The commenter summarized that a permit limit is a permit limit, and it is inconceivable that there is any Federal, state, or local permit that does not carry with it the ability of the issuing authority to ensure and enforce compliance if permit limits are exceeded. The commenter stated that they recognize that reporting, recordkeeping, and monitoring requirements will vary from permit to permit, but that all permits ultimately must be complied with or enforcement consequences from the issuing authority may follow. To the commenter’s knowledge, they stated, there is no permit that does not contain consequences for violations.

Another commenter⁵⁸⁷ likewise was concerned that existing permits in many states may not meet the criteria that the EPA is proposing for legally and practicably enforceable permit terms and believes that the proposed changes will require states to review and revise countless permits and also may require states to engage in rulemakings over and above the efforts states will be required to initiate to implement these rules. The commenter stated that the EPA has neither explained nor justified this policy change, as it must, and should retract it. Another commenter⁵⁸⁸ stated that the proposed criteria for legally and practicably enforceable limits provide no additional benefit and pose several permitting problems.

Similarly, another commenter⁵⁸⁹ believed that states are much better equipped to determine the appropriate methods for the specific circumstances facing industries within their state and that process is required under the EPA’s regulations (when the states meet certain conditions). The commenter was concerned that the proposed requirements conflict with the approach used in both the title V and NSR/PSD permitting programs. Under these programs, the commenter explained, operators may rely on control requirements to limit their PTE that would no longer be available under the proposed rule. In effect, the commenter was concerned, the proposed rule

would arbitrarily require operators to have two different PTE calculations—one for title V and NSR permitting and another for NSPS/EG under this rule. The commenter stated that the definitions of “potential to emit” and “federally enforceable” show that the EPA’s own regulations provide states with substantial latitude to establish “legally enforceable procedures.” The commenter cited to 40 CFR part 51 for the definition of “potential to emit”⁵⁹⁰ and “federally enforceable”⁵⁹¹ and concluded that the TCEQ (Texas Commission on Environmental Quality) emissions limits, established under its EPA-approved SIP, are by the EPA’s own part 51 definitions, federally enforceable. The commenter further noted that the EPA previously determined that the regulations and permits issued by both the TCEQ and the NMED (New Mexico Environment Department) were legally and practicably enforceable. The commenter also stated that in the preamble to the proposed 2013 amendments to NSPS OOOO, the EPA reviewed the regulations in several states to determine which states already had storage tank control requirements for calculating PTE. Based on its evaluation of these regulations, the commenter stated, the EPA determined that several states already had legally and practicably enforceable regulations, including both Texas and New Mexico, such that the EPA could subtract the storage vessels in these states “from the overall count of storage vessels that would be subject to the final rule.” The commenter believed that the EPA’s proposal to require a new definition of “legally and practicably enforceable” substitutes its own judgment as to what is legally and practicably enforceable when its own regulations say that determination should be left to the states, subject to the EPA review. This commenter⁵⁹² and another commenter⁵⁹³ suggested that the SIP review process is the appropriate mechanism as opposed to attempting to

⁵⁸² EPA–HQ–OAR–2021–0317–2298, –2301, –2221, –2254, –2428, –2423, –2399, –2254, –2483, –2227, –2208, –2298, –2292, and –2202.

⁵⁸³ EPA–HQ–OAR–2021–0317–2298, –2301, –2221, –2254, –2428, –2423, –2399, –2254, –2483, –2227, and –2208.

⁵⁸⁴ EPA–HQ–OAR–2021–0317–2301.

⁵⁸⁵ See 86 FR at 63202 (“Only those limits that include the elements described [in the proposed definition] will be considered ‘legally and practicably enforceable’ for purposes of determining the potential for VOC emissions from a single storage vessel or tank battery, and thus applicability (or nonapplicability) of each single storage vessel or tank battery as an affected facility under the rule.”).

⁵⁸⁶ EPA–HQ–OAR–2021–0317–2221.

⁵⁸⁷ EPA–HQ–OAR–2021–0317–2423.

⁵⁸⁸ EPA–HQ–OAR–2021–0317–2428.

⁵⁸⁹ EPA–HQ–OAR–2021–0317–2254.

⁵⁹⁰ “Potential to emit is the maximum capacity of a stationary source to emit a pollutant under its physical and operational design. Any physical or operational limitation on the capacity of the source to emit a pollutant, including air pollution control equipment and restrictions on hours of operation or on the type or amount of material combusted, stored, or processed, shall be treated as part of its design only if the limitation or the effect it would have on emissions is federally enforceable.” See, e.g., 40 CFR 51.165(a)(1)(iii).

⁵⁹¹ “. . . all limitations and conditions which are enforceable by the Administrator . . . [and] requirements within any applicable State implementation plan . . .”. Id. at 40 CFR 51.165(a)(1)(xiv).

⁵⁹² EPA–HQ–OAR–2021–0317–2254.

⁵⁹³ EPA–HQ–OAR–2021–0317–2399.

make changes in this regulation. The commenter⁵⁹⁴ believed that, when given the opportunity to review the regulations of Texas and New Mexico with regard to calculating PTE, the EPA already has determined that those regulations were federally enforceable.

Among other concerns, some commenters⁵⁹⁵ noted that sources do not have methane limits in permits and that prohibiting the use of permits-by-rule and general permits would impose enormous burdens on sources and delegated state authorities, for which the proposal makes no provision. One commenter⁵⁹⁶ was concerned that this prohibition would have a cascading effect on title V determinations across numerous sources, imposing substantial additional burdens and complexities on sources and states. The commenter stated that if the EPA decides to finalize the text, the EPA should recognize that sources in good faith went to the regulator and obtained a permit under the applicable state minor source program and thus, at a minimum, the commenter stated, the EPA should provide flexibility by phasing in the requirement and applying the new definition only when a source needs to apply for a new or revised permit or a permit renewal. Moreover, crucially, for all existing sources, the commenter stated that the EPA should be clear that existing permits authorizing a source to operate remain fully effective, pending state processing of new permits.

Another commenter⁵⁹⁷ similarly believed that the proposed revisions are inconsistent with the EPA's reliance on states to administer the CAA with regard to title V and PSD. That is, the commenter stated, the EPA allows states to establish emissions limits for sites to keep their emissions below title V and PSD permitting thresholds. Monitoring, recordkeeping, and reporting requirements in a permit should be tailored to align with the level of authorization, with minor sources having fewer requirements than major sources, according to the commenter. The commenter recommended that for streamlined permitting mechanisms, such as Permits by Rule in Texas, the state agency would have to engage in rulemaking before operators could rely on such permits for determining storage vessel and tank battery PTE. Such rulemaking could take months to years, meaning that operators cannot rely on legally and practicably enforceable limits until those rule updates are

finalized and effective, according to the commenter.

Response: The EPA recognizes that current permits for NSPS OOOO and OOOOa sources may not entirely meet the criteria that the EPA is finalizing for legally and practicably enforceable limits for purposes of NSPS OOOOb and EG OOOOc. The EPA disagrees, however, that the final rule necessitates that all existing permits be rewritten. These specific criteria do not retroactively apply to permit limits or other requirements that owners and operators had previously relied upon in determining NSPS OOOO or OOOOa applicability to their storage vessels. The criteria will apply when determining NSPS OOOOb applicability to new storage vessels, *i.e.*, those for which construction, reconstruction, or modification commenced after December 6, 2022, and when determining applicability for existing storage vessels covered by the yet-to-be-developed state plans implementing EG OOOOc. For new storage vessels constructed, reconstructed, or modified before the effective date of this final rule, to the extent their owners or operators decided to obtain legally and practicably enforceable limits to cap the potential emissions from their storage vessels below the proposed NSPS OOOOb applicability thresholds, those owners or operators were on notice of the EPA's proposed LPE criteria when obtaining such limits. Accordingly, the EPA does not agree that it is necessary to provide a transitional period for sources to obtain or revise permits before applying the new LPE criteria for determining applicability of the storage vessel standards under NSPS OOOOb or under future state and/or Federal plans implementing EG OOOOc.

With regard to existing sources, the EPA notes that existing permits for designated facilities will need to be reopened to include legally and practicably enforceable methane emission limits to the extent facilities want to take into account such limits in determining storage vessel standards applicability. States that use permit-by-rule or general permits have the discretion to evaluate at any time (including now or as they develop their state plans to implement EG OOOOc) whether to modify those rules to incorporate the new criteria for legally and practicably enforceable limitations.

The EPA notes that for both new and existing sources, it is a voluntary decision on the part of an owner or operator to obtain a permit with "legally and practicably enforceable" criteria in order to avoid having to comply with the applicable standard in NSPS

OOOOb or a state or Federal plan pursuant to EG OOOOc. A source may opt to comply with the underlying rule when the potential for VOC or methane emissions exceeds the relevant applicability thresholds. In the future, the EPA may initiate further rulemaking to address this provision if its implementation merits further regulatory action.

The EPA disagrees that the criteria the EPA is promulgating conflict with other CAA programs, such as title V and NSR programs. The EPA cannot understand how more specific criteria for a specific purpose within NSPS OOOOb can undermine compliance with title V and NSR permits, and the commenter did not provide specific examples that the EPA could review. Further, while the LPE criteria being finalized here may be more stringent than what states are currently using for other contexts, the commenter has not identified any direct conflict that would prevent the commenter from meeting the criteria in other programs, as more stringent criteria can be used to demonstrate compliance with less stringent requirements.

In response to the comment that approved SIP rules are federally enforceable, the EPA agrees. The EPA's promulgation of NSPS OOOOb and EG OOOOc does not affect previously approved SIP actions that incorporate NSPS OOOO or OOOOa. The EPA is establishing requirements for sources subject to NSPS OOOOb and EG OOOOc to show ongoing compliance with the NSPS, and if the revised NSPS subparts are adopted and approved as part of a SIP, the LPE criteria provisions will be federally enforceable for permits issued within the state. The EPA routinely revises such standards to address the next generation of sources. In this instance EPA is adding a pollutant and further defining how legally and practicably enforceable limits must be supported by site-specific information that supports an operator's claim to be operating within those limits, in compliance with the rule.

As the commenters note, in 2013,⁵⁹⁸ the EPA found that 11 states already required control devices for storage vessels, including both Texas and New Mexico, such that the EPA could subtract the storage vessels in these states "from the overall count of storage vessels that would be subject to the final rule."⁵⁹⁹ However, the purpose of referring to those state regulations was in order to estimate the total number of storage vessels that would need to be

⁵⁹⁴ EPA-HQ-OAR-2021-0317-2254.

⁵⁹⁵ EPA-HQ-OAR-2021-0317-2399 and -2428.

⁵⁹⁶ EPA-HQ-OAR-2021-0317-2399.

⁵⁹⁷ EPA-HQ-OAR-2021-0317-2428.

⁵⁹⁸ 78 FR 22126 (April 12, 2013).

⁵⁹⁹ 78 FR 22130.

controlled nationwide and evaluate whether there were enough control devices available to owners and operators of storage vessels for implementation of the rule in the process of considering a petition for reconsideration. The EPA disagrees with the commenter's assertion that the EPA made a "determination" as to the adequacy of the state permitting regulations for purposes of determining applicability of the NSPS. In particular, the EPA did not make any determination as to the legal and practicable enforceability of the state permitting regulations, including for Texas or New Mexico.

Regarding the concern that existing sources do not have methane limits in permits now, CAA section 111(d) and the EPA's implementing regulations in 40 CFR part 60, subpart Ba, mandate that states adopt plans to set performance standards for designated pollutants; for purposes of EG OOOOc, the designated pollutant is GHGs, and the presumptive standards in EG OOOOc are expressed in the form of methane. Therefore, only permit limits on methane emissions can be included in determining applicability of the methane standards for storage vessels in the applicable state or Federal plan implementing EG OOOOc. The EPA agrees with the commenter that a reasonable period of time may be required to adopt state plans consistent with EG OOOOc, including to revise permit limits for storage vessels that choose to be subject to a legally and practicably enforceable limit below the methane applicability threshold. For that reason, as discussed in section XIII.E.2, the EPA has allowed states 24 months to carry out state rulemaking activity to adopt the appropriate standards. In addition to the 24 months, the EPA requires that states establish compliance deadlines that require compliance with the final state plan within 36 months following the state plan submittal deadline, providing up to 5 years for existing sources to adapt their systems to new Federal and state standards before compliance would be required. Further, because permits for existing sources will need to be reopened to include the final state plan criteria implementing the EG, the EPA does not believe that there is a substantial additional burden in ensuring that the "legally and practicably enforceable" criteria are met.

Commenters are correct that, consistent with the finalization of the "legally and practicably enforceable" criteria, the EPA may determine that some permit limits do not meet the

criteria and the tank battery cannot use those limits when determining the potential for VOC and methane emissions; however, the EPA always has the authority to independently assess claims of nonapplicability. Regarding friction with states, as stated previously, the EPA believes finalizing the criteria will provide states with the needed level of specificity and certainty to issue permits that meet the "legally and practicably enforceable" criteria.

c. LPE Criteria

Comment: Several commenters⁶⁰⁰ were concerned with the specific criteria provided for LPE. One commenter⁶⁰¹ stated that permits have proposed annual or rolling 12-month limits on emissions and production because the tank PTE thresholds and NSR permitting thresholds are based on annual emissions. The commenter believed that the EPA should clarify that such annual limits meet the proposed 30-day averaging time for production limits especially since facilities are typically permitted for a worst-case scenario. Another criterion likely not in existing permits is "*periodic reporting that demonstrates continuous compliance*," according to the commenter. Historically, the commenter pointed out, periodic reporting has applied to major sources under title V and affected facilities regulated under a NSPS or NESHAP, which the commenter stated is a small fraction of the sites that will be regulated under NSPS OOOOb and EG OOOOc.

Another commenter⁶⁰² stated that the requirements for legally and practicably limiting the "potential for methane emissions" are unclear and conflict with the definition of "potential to emit." Specifically, the commenter stated:

- It is unclear why the EPA has proposed that production limits must be accompanied by operational limits in order to be legally and practicably enforceable. 40 CFR 60.5386c(e)(2)(i)(A).

- It is unclear how a source would establish parametric limits for production and/or operational limits. 40 CFR 60.5386c(e)(2)(i)(C).

- It is unclear how a source would use a control device to meet an operational limit. 40 CFR 60.5386c(e)(2)(i)(C).

The same commenter stated that the EPA should refer to the available caselaw and guidance on limiting "potential to emit" to ensure that the use of terms such as "production limit,"

"operational limit," and "parametric limit" in the proposed rules are consistent with the widely accepted use of those terms in air permitting programs. One commenter⁶⁰³ expressed concern that proposed 40 CFR 60.5365b(e)(2)(i)(A), which requires a "quantitative production limit and quantitative operational limit(s) for the equipment, or quantitative operational limits for the equipment," is inconsistent with longstanding EPA policy. The commenter believed that production and/or operational factors can be used as part of a parametric calculation of emissions, but they need not be standalone.⁶⁰⁴ Next, the commenter stated that proposed 40 CFR 60.5365b(e)(2)(i)(B) requires an averaging period of less than 30 days when a production-based limit is used, but the commenter believed that is arbitrary and capricious, as well as inconsistent with EPA policy where the overall standard that the limit is intended to enforce is a tpy (*i.e.*, annual) standard. In such a case, as here, a 12-month rolling limit, as long as it is well-defined in how it is calculated, is more than adequate, according to the commenter.⁶⁰⁵ Finally, the commenter stated that it takes issue with proposed 40 CFR 60.5365b(e)(2)(i)(C) which requires that "where a control device is used to achieve an operational limit, an initial compliance demonstration (*i.e.*, performance test) for the control device [] establishes the parametric limits." While the commenter agreed that the regulations should certainly allow the use of a compliance demonstration, presumably in the form of a test, there is no reason for the EPA to preclude other means of estimating the control device efficiency, such as AP-42 factors or vendor-provided factors, especially when these factors are known to be conservative.

Response: With respect to the proposed 30-days-or-less averaging time period for a production-based limit, the EPA agrees that a rolling 12-month

⁶⁰³ EPA-HQ-OAR-2021-0317-2483.

⁶⁰⁴ See, *e.g.*, In re. Salt River Project Agua Fria Generating Station], Petition No. IX-2022-4, at 12-13 (Adm'r July 28, 2022), available at https://www.epa.gov/system/files/documents/2022-08/SRP%20Agua%20Fria%20Order_7-28-22.pdf, ("EPA does not interpret the Federal regulations to require production and/or operating limits in all situations.")

⁶⁰⁵ See, *e.g.*, Memorandum from John S. Seitz, Director, EPA Office of Air Quality Planning and Standards, to EPA Regional Air Division Directors, Options for Limiting the PTE of a Stationary Source Under Section 112 and title V of the Clean Air Act, at 6 (January 25, 1995), available at <https://www.epa.gov/sites/default/files/documents/limit-pte-rpt.pdf> (explaining that "annual limits such as rolling annual limits" are appropriate to practically enforce an annual emission limitation).

⁶⁰⁰ EPA-HQ-OAR-2021-0317-2222, -2483, -2399, and -2428.

⁶⁰¹ EPA-HQ-OAR-2021-0317-2428.

⁶⁰² EPA-HQ-OAR-2021-0317-2222.

average is an acceptable alternative to a month-by-month determination, where the rolling 12-month average is supported by 30-day subtotals, beginning in the first 30 days, and redetermined every month. This is consistent with the EPA's longstanding guidance, which expresses the Agency's "preference toward short term limits, generally daily but not to exceed a month."⁶⁰⁶ The 30-day averaging time is particularly needed here because determination of potential emissions (and in turn storage vessel standards applicability) is required within the first 30 days after startup of production for tank batteries at well sites and centralized production facilities; an averaging period longer than 30 days would mean there will not be sufficient data to estimate potential emissions by the 30-day deadline whether the production limit effectively caps a tank battery's potential emissions below the applicable threshold(s) under NSPS OOOOb or EG OOOOc. Therefore, when establishing permit limits on production or operation, the EPA believes that such limits should not exceed 30 days. The EPA also points out that a violation of a 12-month standard without any prior interval to verify compliance has the potential to create a full year of noncompliance and associated penalties for failure to demonstrate ongoing compliance.

Regarding production limits and operational limits, the final rule provides that if a production limit is used, it must be accompanied by operational limits to be legally and practicably enforceable because in that situation, potential VOC and methane emissions from a storage vessel are a function of both the facility's operational conditions and production rates. Therefore, both are inputs to the storage vessel emissions calculations. Also, because changes in either may result in an increase in vessel emissions, monitoring is required for both the operational conditions and the production rates used to establish emissions from the storage vessel.

The EPA does not believe, and the commenter did not explain how, the usage of "production limit," "operational limit," and "parametric limit" in the proposed rules is inconsistent with the widely accepted use of those terms in air permitting programs. The EPA clarifies that an operational limit on a control device is typically the claimed reduction

efficiency of the control system, such as the destruction efficiency of a flare or availability of the VRU to route vapors to process. To demonstrate compliance with such operational limits, parametric limits for a control device are established during manufacturer or source-specific performance testing of the device. The EPA clarifies that "parametric limits" refer to limits on a parameter that can act as a reliable indicator of an emissions-producing (or emissions-reducing) activity or process. Parametric limits for control devices can include flow rate, inlet pressure, residence time, combustion zone temperature, or similar metrics.

Regarding the comment on the use of AP-42 and vendor-provided emission factors for estimating control efficiency of control devices, the EPA clarifies that the proposed LPE criteria do not preclude such use of emission factors. Rather, the criteria require an initial compliance demonstration (*i.e.*, performance testing) for a control device to establish parametric limits where a control device is used to achieve an operational limit. It is not clear, and the commenter did not explain how, AP-42 or vendor-provided emission factors could be used to establish parametric limits. The EPA is therefore finalizing the LPE criteria as proposed.

2. Modification

Comment: Several commenters⁶⁰⁷ expressed concern that the EPA has departed from the definition of modification found at 40 CFR 60.14. One commenter⁶⁰⁸ recommended that the EPA limit modifications to where the operator increases emissions from the tank battery by increasing the capacity of the tank battery. The commenter explained that as proposed, subparagraphs (A) and (B) of 60 CFR 60.5365b(e)(3)(ii) would trigger a potential modification even where the increase in capacity of the tank battery is not accompanied by an increase in the tank battery's emissions rate. The commenter stated that operators may readily track and document the addition or replacement of storage vessels within a tank battery. The commenter cautioned that if the EPA does not define modification to require an increase in the emissions rate of the tank battery, perverse outcomes may occur. By way of example, the commenter explained that an operator may increase the size of tank battery without increasing the emissions from the tank battery, and if the emissions

(which have not changed) exceed the applicability threshold, the tank battery would become an affected facility. The commenter explained that this possibility is real given that the EPA now proposes to apply the 6 tpy VOC and 20 tpy methane applicability thresholds to the entire tank battery, where it previously under NSPS OOOO and NSPS OOOOa used the same VOC threshold but on an individual storage vessel basis, which effectively reduces the NSPS applicability threshold proportionally by the number of individual storage vessels in a tank battery.

Regarding subparagraphs (C) and (D) of 40 CFR 60.5365b(e)(3)(ii), the same commenter⁶⁰⁹ explained that per 40 CFR 60.14(e)(2), an increase in throughput for a storage vessel, accomplished without a capital expenditure on that storage vessel, is not considered a modification and the EPA has not fully explained why it is proposing to deviate from the historical legal understanding of modification which requires both an increase in throughput and a capital expenditure on the storage vessel or tank battery. Other commenters⁶¹⁰ expressed similar concerns regarding capital expenditure. Two commenters⁶¹¹ noted that increases in liquid throughput at well sites, central production facilities, and compressor stations are difficult to track, as operators typically track liquid throughput using tank gauging rather than flow meters. Further, one commenter⁶¹² explained, the modification criteria for tank batteries at well sites and centralized production sites serve as a disincentive to the centralization of facilities, as the addition of production from a new well to an existing centralized production facility would trigger a modification under 40 CFR 60.5395b(e)(3)(ii)(C). The commenter urged the EPA to consider that if the EPA does not remove the criteria at 40 CFR 60.5395b(e)(3)(ii)(C), the increase in liquid throughput also must be accompanied by a capital expenditure on the tank battery itself. The commenter explained that some actions, such as drilling a new well or fracturing or refracturing an existing well, could increase liquid throughput and require capital expenditure but not necessarily on the tank battery itself.

The same commenter⁶¹³ recommended other clarifications to

⁶⁰⁶ See memorandum, *Options for Limiting the Potential to Emit (PTE) of a Stationary Sources under Section 112 and Title V of the Clean Air Act (Act)*. <https://www.epa.gov/sites/default/files/2015-07/documents/ptememo.pdf>.

⁶⁰⁷ EPA-HQ-OAR-2021-0317-2326, -2428, and -2399.

⁶⁰⁸ EPA-HQ-OAR-2021-0317-2326.

⁶⁰⁹ EPA-HQ-OAR-2021-0317-2326.

⁶¹⁰ EPA-HQ-OAR-2021-0317-2428 and -2399.

⁶¹¹ EPA-HQ-OAR-2021-0317-2326 and -2428.

⁶¹² EPA-HQ-OAR-2021-0317-2326.

⁶¹³ EPA-HQ-OAR-2021-0317-2326.

subparagraph 40 CFR 60.5395b(e)(3)(ii)(C). First, the commenter believed that the EPA should remove the reference to “process unit” in subparagraph (C), because “process unit” is defined in the rule within the context of facilities that process natural gas, not well sites and centralized production facilities, and that the reference to process unit in the context of well sites and centralized production facilities is confusing and misplaced. Second, the commenter stated that the EPA should limit the scope of subparagraph (C) to “actions taken with respect to equipment that directly, or through a series of equipment, provides crude oil, condensate, intermediate hydrocarbons, or produced water throughput to the tank battery, including the addition of, or change to, a production well (including hydraulic fracturing or refracturing of the well).” By way of example, the commenter explained that hydraulic fracturing activities occurring in the vicinity of a well that delivers produced liquids to a storage tank battery may temporarily increase production of the well, which would, in turn, increase throughput of the tank battery, but as drafted, it is unclear whether this increase in production is an “action” that modified the tank battery if it resulted in exceedance of the potential for emissions threshold. The commenter believed the increase in production should not be considered an action, as operators cannot plan for or anticipate increases in production from activities occurring offsite that are outside the scope of operations associated with the tank battery. Further, in this example, the commenter explained that the cause of a temporary increase in production may be unknown to the operator and considering “actions” having no direct relationship to equipment in the definition of modification would be a far and extreme departure from longstanding NSPS modification principles. If the EPA retains these modification triggers, the commenter requested that well sites and centralized production facilities also be allowed to compare liquid throughputs to limits in a legally and practicably enforceable permit as is allowed for compressor stations and natural gas processing plants. The commenter believed this recommendation would also make modification criteria consistent for all sites and clearly define what an increase in liquid throughput is.

Similarly, one commenter⁶¹⁴ stated that the December 2022 Supplemental

Proposal is not only inconsistent with the statutory definition of “modification” but also inconsistent with the EPA’s prior interpretation that a “modification” requires some physical change to a tank. See Letter from Valdus Adamkus, EPA Region 5, to Bradley Miller, Hamilton County Environmental Services (March 25, 1996)⁶¹⁵ (increase in vapor pressure resulting in increased tank emissions was not a “modification” under 40 CFR part 60, subpart Kb because there were no physical changes to the tank). The commenter was concerned that, unless the proposed definition of “modification” is revised to require a physical change or change in the method of operations, midstream owners and operators could find their equipment “modified” solely based on the decisions of upstream third parties and without taking any action themselves.

Another commenter⁶¹⁶ provided some specific recommendations, if the EPA decides to include increases in liquid throughput as a criterion for modification:

- *The increase in liquid throughput must also be accompanied by a capital expenditure on the tank battery itself.* Actions, such as drilling a new well or fracturing or refracturing an existing well, could increase liquid throughput and require capital expenditure but not necessarily on the tank battery itself. These actions would not be considered modifications to the tank battery unless there is capital expenditure on the tank battery itself. This recommendation would make NSPS OOOOb consistent with the general provisions in 40 CFR 60 subpart A.

- *Reference to process unit in 40 CFR 60.5365(e)(ii)(C) should be removed since process unit is defined such that they should not exist at well sites and centralized production facilities.*

Process unit is a term specific to natural gas processing plants and does not apply to well sites and centralized production facilities.

- *Well sites and centralized production facilities should also be allowed to compare liquid throughputs to limits in a legally and practicably enforceable permit like compressor stations and natural gas processing plants.* The EPA should be consistent and allow well sites and centralized production facilities to compare liquid throughputs to limits in a legally and

practicably enforceable permit since such a permit can be relied upon for the PTE determination for all sites.

- *In the absence of a legally and practicably enforceable limit, all sites should be allowed to compare liquid throughputs to those used to design the existing cover and closed vent system in operation when a potential modification action occurs.* These recommendations would also make modification criteria consistent for all sites and clearly define what an increase in liquid throughput is.

The same commenter⁶¹⁷ offered suggested edits to 40 CFR 60.5365b(e)(3)(ii) consistent with their recommendations.

Response: The EPA is finalizing the provisions regarding modification as proposed, except for minor edits to the regulatory text at 40 CFR

60.5365b(e)(3)(ii) to replace “result in” with “occurs” such that the provision is as follows: “‘Modification’ of a tank battery occurs when any of the actions in paragraphs (e)(3)(ii)(A) through (D) of this section occur and the potential for VOC or methane emissions meets or exceeds either of the thresholds specified in paragraphs (e)(1)(i) or (ii) of this section.” The EPA is making this change because the EPA already has determined that the actions described in 40 CFR 60.5365b(e)(3)(ii)(A) through (D) result in an emissions increase, and the term “result in” may be incorrectly interpreted to suggest otherwise.

CAA section 111(a)(4) defines “modification” as “any physical change or operational change in a stationary source which increases the amount of any air pollutant emitted by such source” While the general provisions at 40 CFR 60.14 provide a definition of modification, 40 CFR 60.14(f) specifically authorizes the EPA to provide subpart-specific definition for “modification” that would supersede any conflicting provision in 40 CFR 60.14. Pursuant to its authority under 40 CFR 60.14(f), the EPA proposed to define “modification” of a tank battery under NSPS OOOOb (40 CFR 60.5365b(e)(3)(ii)) to mean when the potential emissions of the tank battery exceed the 6 tpy VOC or 20 tpy methane threshold following any of the following physical or operational changes:

(A) a storage vessel is added to an existing tank battery;

(B) one or more storage vessels are replaced such that the cumulative storage capacity of the existing tank battery increases;

(C) for tank batteries at well sites or centralized production facilities, an

⁶¹⁵ See https://cfpub.epa.gov/adi/index.cfm?fuseaction=home.dsp_show_file_contents&CFID=1949573&CFTOKEN=fb4fc82ba0b35cd4-2102140A-E016-B8E6-76946EF822FC87A4&id=96600032.

⁶¹⁶ EPA-HQ-OAR-2021-0317-2428.

⁶¹⁷ EPA-HQ-OAR-2021-0317-2428.

⁶¹⁴ EPA-HQ-OAR-2021-0317-2399.

existing tank battery receives additional crude oil, condensate, intermediate hydrocarbons, or produced water throughput from actions, including but not limited to, the addition of operations or a production well, or changes to operations or a production well (including hydraulic fracturing or refracturing of the well); or

(D) for tank batteries at compressor stations or onshore natural gas processing plants, an existing tank battery receives additional fluids which cumulatively exceed the throughput used in the most recent (*i.e.*, prior to an action in paragraphs (e)(3)(ii)(A), (B) or (D) of this section) determination of the potential for VOC or methane emissions.

The EPA did not propose to require a showing of an emission increase, having determined that each of the four scenarios describes a physical or operational change that results in an emission increase. With respect to scenarios (A) and (B) above, the EPA explained in the November 2021 Proposal that even if the type and quantity of fluid processed remain the same, the increased storage capacity will lead to higher breathing losses and thereby increase emissions from the tank battery. See 86 FR 63198. With respect to scenario (C), as the EPA explained in the November 2021 Proposal (86 FR 63199) and reiterated in the December 2022 Supplemental Proposal (87 FR 74802), “actions occurring at a well site, such as refracturing a well or adding a new well that sends these liquids to the tank battery at the well site or centralized production facility, would result in an increase in VOC and methane emissions based on an increase in volumetric throughput to the tank battery.” With respect to scenario (D), which addresses storage vessels at compressor stations and gas processing plants, the EPA acknowledges that “storage vessels at these locations are designed to receive liquids from multiple well sites that may startup production over a longer period of time”; the EPA therefore “agrees that when a tank battery at a compressor station or onshore natural gas processing plant receives additional throughput which has already been accounted for in the design capacity of that tank battery and included as a legally and practically enforceable limit in a permit for the tank battery, that additional throughput does not result in an emission increase from the tank battery because those emissions have already been accounted for in the permit.” (87 FR 74802). In other words, there is emission increase under scenario (D) when the emissions from the additional throughput is not

accounted for in the design capacity of the tank battery.

While the EPA has determined that an emissions increase results from each of the four scenarios described in 40 CFR 60.5365b(e)(3)(ii), none of them automatically result in the potential for VOC or methane emissions to be at or above the VOC or methane emissions thresholds in NSPS OOOOb; each of the scenarios would trigger the need to complete the “potential for VOC or methane emissions” determination under 40 CFR 60.5365b(e)(1)(ii).

The EPA disagrees with the comment that modification based on an increase in the tank battery’s capacity (*i.e.*, scenarios (A) and (B)) must be accompanied by an increase in the tank battery’s emission rate and that modification based on increased throughput (*i.e.*, scenarios (C) and (D)) must be accompanied by a capital expenditure. As mentioned above, CAA section 111(a)(4) defines “modification” as “any physical change or operational change in a stationary source which increases the amount of any air pollutant emitted by such source” The statutory definition does not require that there be an increase in an “emission rate,” and it makes no reference to “capital expenditure”; therefore, neither is requisite to determining modification. Further, 40 CFR 60.14(f) authorizes the EPA to set forth “[s]pecial provisions . . . under an applicable subpart of this part [that] shall supersede any conflicting provisions of this section.”

With respect to scenarios (A) and (B), as explained above, the EPA determined that an increase in tank battery capacity (scenarios (A) and (B)) will always increase the emissions from that tank battery. The commenters do not mention, much less disagree with or question, the EPA’s rationale. Having already determined that scenarios (A) and (B) increase emissions, there is no need to require emission rate calculation for purposes of determining whether there is an emission increase under these scenarios. The EPA therefore declines the suggestion to require that scenarios (A) and (B) be accompanied by an increase in the tank battery’s emission rate.

With respect to scenarios (C) and (D), the commenters did not explain why these scenarios must be accompanied by a capital expenditure other than pointing to 40 CFR part 60, General Provisions, 40 CFR 60.14(e)(2), which exempts from “modification” a facility that increases its production rate (and thus emissions) but without a capital expenditure on that facility. The EPA notes that this exemption was

promulgated in 1975, at the early stage of the EPA’s CAA section 111 rulemaking. The EPA had just first promulgated NSPS for the first five listed source categories (steam generators, portland cement plants, incinerators, nitric acid plants, and sulfuric acid plants) a few years earlier in 1971.⁶¹⁸ All of these facilities were traditional industrial plants; there is no indication that in those earlier years of CAA section 111 rulemakings, the EPA had the occasion to evaluate more complex and unique source categories such as the crude oil and natural gas source category, where a physical or operational change at one affected facility (*e.g.*, fracking of a well) causes physical/operational change and emission increase at another affected facility (a tank battery). What is clear is that 40 CFR 60.14(f), which the EPA promulgated concurrently with 40 CFR 60.14(e), authorizes the EPA to establish in individual rule subparts provisions that supersede any conflicting provisions in 40 CFR 60.14(e). As explained earlier, under scenarios (C) and (D), there is always a physical/operational change and emission increase at a tank battery when receiving additional throughput; this is the case whether or not there is capital expenditure on the tank battery. However, 40 CFR 60.14(e) would exempt tank batteries under scenarios (C) and (D) from regulation if there is no capital expenditure, even if they have potential emissions above the thresholds established in this rule. The EPA does not believe, and the commenters do not explain why, such exemption is justified. Therefore, the EPA declines to include a requirement that there be a capital expenditure under scenarios (C) and (D).

With respect to the comment claiming that the EPA previously interpreted “modification” to require physical change to a tank, the 1996 EPA letter that the commenter cited as support made no such pronouncement. Further, the letter addressed applicability of a storage tank regulated under the New Source Performance Standard, subpart Kb, and the exemption at issue was 40 CFR 60.14(e)(4) (use of an alternative fuel or raw material that the existing facility was designed to accommodate). It is not clear, and the commenter did not elaborate, how that determination applies here, not to mention that the EPA has since taken a different

⁶¹⁸ 36 FR 24876 (December 23, 1971).

position.⁶¹⁹ The EPA therefore made no change in response to this comment.

We agree with a commenter's suggestion of removing the term "process unit" from proposed 40 CFR 60.5365b(e)(3)(ii)(C), which in the December 2022 Supplemental Proposal defined "modification" of tank batteries at well sites or centralized production facilities as when "an existing tank battery receives additional crude oil, condensate, intermediate hydrocarbons, or produced water throughput from actions, including but not limited to, the addition of a process unit or production well, or changes to a process unit or production well (including hydraulic fracturing or refracturing of the well). We agree with the commenter that the term "process unit," as defined in the proposed NSPS OOOOb and EG OOOOc, relates specifically to natural gas processing plants. In the final rule, the EPA has substituted the term "process unit" with "operations," a more generic term to cover activity that could result in additional product throughput to a tank battery at a well site or centralized production facility.

Regarding the comment that in the absence of a legally and practicably enforceable limit, all sites should be allowed to compare liquid throughputs to those used to design the existing cover and closed vent system in operation when a potential modification action occurs, the EPA disagrees because the throughput used in the design analysis for the cover and closed vent system itself is not a legally and practicably enforceable limit on throughput. The design analysis also may include emissions from other than a storage vessel affected facility, making it difficult to extract the contribution from the tank battery. Finally, if the prior determination (*i.e.*, before one of the potential modification actions) was that the tank battery was not a storage vessel affected facility, then the requirements to control the tank battery and design and operate a cover and closed vent system would not apply and no record of the cover and closed vent system design would exist.

The EPA must defer to a case-by-case determination on the comment asking that the EPA determine whether an action ". . . from activities occurring off-site that are outside the scope of operations associated with the tank battery" is not an action that results in

a modification because of the seemingly site-specific circumstances of the example. The commenter seems to be citing an example of hydraulic fracturing at a nearby well that induces a change in throughput to tanks at another unrelated well site or centralized production facility. Regarding temporary increases in throughput, the modification actions do not have a temporal element. For the reasons discussed in the November 2021 Proposal, the EPA believes the actions will result in emissions increase to the atmosphere. See 86 FR 63198. Limitations on throughput may be accounted for in a legally and practicably enforceable limit when determining the potential for VOC and methane emissions, which determination is conducted after one of the actions occurs.

Regarding the comment that an owner or operator has difficulty tracking liquid throughput because operators typically track liquid throughput using tank gauging rather than flow meters, the EPA clarifies that the final rule does not require any specific equipment for tracking throughput and, therefore, throughput can be tracked using gauging.

Regarding the comment that the owner or operator of midstream tank batteries at compressor stations or natural gas processing plants has no control over the receipt of fluids from upstream production facilities owned by third parties, as explained above, as long as the additional throughput is accounted for in the design capacity of the tank battery, the additional throughput does not result in an emissions increase from the tank battery because those emissions have already been accounted for in the permit. See 87 FR 74802. The EPA proposed language to that effect at 40 CFR 60.5365b(e)(3)(ii)(D) and 60.5365b(e)(2)(iii)(A) and (B). The EPA therefore is finalizing, as proposed, the requirements regarding modification actions at natural gas processing plants and compressor stations. In summary, a tank battery at a natural gas processing plant and compressor station is considered to be modified if one of the actions (adding a storage vessel to an existing tank battery, replacing one or more storage vessels such that the cumulative capacity of the tank battery increases, or the existing tank battery receives additional fluids which cumulatively exceed the throughput used in most recent determination of the potential for VOC or methane emissions) occurs and the potential for VOC or methane emissions meets or exceeds the thresholds.

Regarding the comment that the modification criteria create a disincentive to the centralization of facilities, the EPA is not persuaded that operators locate and design their tank batteries to avoid modification determinations because at some point in the future a well may be added to route product to the tank battery, and the EPA believes the decisions are based on the economics of well production. The EPA notes that our BSE analysis has determined that it is cost-effective to control emissions of VOC and methane at 6 tpy and 20 tpy, respectively, regardless of the number or the location of the tank batteries.

The EPA here reiterates that modification requires two conditions—that (1) one of the actions in 40 CFR 60.5365b(e)(3)(ii) (A) through (D) occurs, and (2) the potential for emissions from the tank battery meets or exceeds 6 tpy VOC or 20 tpy methane (applicability determination). With regard to the comment that an increase in the size of a tank battery alone would trigger applicability, that is not the case. The applicability determination must be performed within 30 days under 40 CFR 60.5365b(e)(2)(ii) after adding the storage vessel or replacing a storage vessel with another storage vessel of greater capacity, and where the applicability determination indicates that emissions are less than 6 tpy VOC or 20 tpy methane, the storage vessel would remain an unaffected facility under NSPS OOOOb.

Comment: Several commenters⁶²⁰ were concerned about the modification provisions related to replacement of a storage tank. One commenter⁶²¹ stated that an operator of an unregulated tank or tank in a battery that reaches the end of its safe operational life and must be replaced should not be required to have to prove that the tank or tank battery should still be unregulated. The commenter explained that many oil and gas wells typical of legacy production are limited in their productive life only by the life of the tubulars in them (as exhibited by the many 100-year-old-plus wells still producing in the Appalachian Basin of east Kentucky). The commenter believed that operators should be permitted to replace equipment in kind (*e.g.*, akin to a "standard set" for the refining industry) and should not be burdened with potentially expensive compliance activities for replacing equipment that has reached the end of its useful life. The commenter expressed that they believed that if the EPA

⁶¹⁹ See "New Source Performance Standards Review for Volatile Organic Liquid Storage Vessels (Including Petroleum Liquid Storage Vessels); Proposed Rule," 88 FR 63535 (October 3, 2023) (proposing to reinterpret the applicability of 40 CFR 60.14(e)(4) to not apply to changes in the organic liquid stored in a storage vessel).

⁶²⁰ EPA-HQ-OAR-2021-0317-2172, -2298, and -2248.

⁶²¹ EPA-HQ-OAR-2021-0317-2172.

finalizes the modification provisions as proposed, many operators will not replace equipment and that those modification provisions would result in more emissions from equipment not being replaced to avoid the EPA's compliance requirements. Another commenter⁶²² recommended that replacement of a tank that only increases battery capacity should not trigger a modification because, the commenter states, an increase in tank capacity does not equal an increase in emissions and, therefore, should not be considered a modification under any rule.

One of the commenters⁶²³ expressed concern about the modification provisions related to relocation of a storage vessel. The commenter stated that certain activities the EPA is proposing which potentially trigger a modification include activities that are not a "physical change in, or change in the method of operation of, a stationary source" as required by CAA section 111(a)(3). By way of example, the commenter pointed out that the definition of modification in the proposed rule could include the relocation or replacement of a storage vessel. The commenter also stated that they do not believe that the EPA has demonstrated the necessity of this change or how its implementation will benefit the environment.

Response: The EPA believes that scenarios regarding the relocation of an existing tank battery or replacement "in like kind" (*i.e.*, the cumulative throughput capacity is not increased) are not governed by the modification provisions, but are akin to relocation and reconstruction provisions, respectively. See discussion below which clarifies which provisions (*i.e.*, construction, reconstruction, modification, or return to service) would need to be evaluated under different tank replacement or relocation scenarios. On the other hand, replacement of a tank that adds capacity to the tank battery constitutes a modification. The EPA assumes that a facility adding storage capacity anticipates an increase in production, which will lead to higher emissions from the tank battery (86 FR 63199). Further, as mentioned earlier, even if the type and quantity of fluid processed remain the same, the increased storage capacity will lead to higher breathing losses and thereby increase emissions from the tank battery. See 86 FR 63198. The commenter does not dispute that, much less providing a reason why,

either of these rationales is incorrect. Therefore, the definition of "modification" in the final rule, specifically 60.5365b(e)(3)(ii)(A) and (B), is unchanged.

Regarding the comment on relocation, the EPA wishes to clarify which provisions (*i.e.*, construction, reconstruction, modification, or return to service) would need to be evaluated under different tank replacement or relocation scenarios. When one or more tanks in an existing tank battery are replaced, but the cumulative storage capacity does not increase nor are tanks added to the total number, the replacement is not a "modification" as defined in 40 CFR 60.5365b(e)(3)(ii)(A) and (B); however, if more than half of tanks in an existing tank battery are replaced, such replacement is "reconstruction" under 40 CFR 60.5365b(e)(3)(i) if, after such replacement, the tank battery has the potential for 6 tpy or more of VOC emissions or 20 tpy or more of methane emissions (see comments and responses related to reconstruction in section XI.J.3 of the preamble). If a storage vessel affected (or designated) facility or portion of a storage vessel affected (or designated) facility that had been taken out of service is later returned to service (*i.e.*, reconnected to the original source of liquids), it remains a storage vessel affected facility subject to the same requirements that applied before its being removed from service (see 40 CFR 60.5365b(e)(6) (or 60.5386c(e)(5)). If an existing tank battery is relocated, with no actions described in the modification provisions at 40 CFR 60.5365b(e)(3)(ii) taking place, and without replacement of any tanks or other components in the tank battery, then there is no modification or reconstruction of the relocated tank battery. Further, if this existing tank battery was determined not to be a designated facility under EG OOOOc (*i.e.*, the potential methane emissions are less than 20 tpy), relocation of the existing tank battery does not change that status. Additional examples of the outcomes of certain actions regarding modification may be found in the December 2022 Supplemental Proposal. See 87 FR 74802.

3. Reconstruction

Comment: One commenter⁶²⁴ believes that the proposed definition of reconstruction is internally inconsistent. The commenter cites to the EPA's rationale in the proposal that for a tank battery consisting of more than one storage vessel, reconstruction is based

on replacing at least half of the storage vessels based on the assumption that "the cost of replacing storage vessel components such as thief hatches and pressure relief devices, in comparison to the cost of constructing an entirely new storage vessel affected facility, will not exceed 50 percent of the cost of constructing a comparable new storage vessel affected facility." However, the commenter points out, for a tank battery consisting of a single storage vessel, the existing provisions of 40 CFR 60.15 apply on the chance that the cost of replacement storage vessel components could be 50 percent or more of the cost to construct a comparable new storage vessel. The commenter explains that the cost of depreciable components on a storage vessel other than the tank itself either could be or could not be 50 percent or more of the cost of a new comparable tank. The commenter is concerned that this inconsistency means that operators would have to track the cost of storage vessel component replacements for single storage vessel tank batteries, but not for multi-vessel tank batteries. For both single- and multi-vessel tank batteries, the commenter believes that operators should have the option to track either storage vessel replacements or all depreciable components and provided suggested regulatory changes reflecting their recommendations.

Response: The EPA agrees that there appeared to be an inconsistency in the discussion in the December 2022 Supplemental Proposal with respect to why the EPA proposed to define "reconstruction" differently for a tank battery with more than one storage vessel and a tank battery with a single storage vessel. For the former, the EPA proposed to simplify and streamline the reconstruction determination by defining reconstruction at a tank battery with more than a single storage vessel as replacement of 50 percent of the storage vessels in the tank battery. This was based on the EPA's expectation that when an affected facility is replacing one or more storage vessels in a tank battery, the capital costs for the individual storage vessel replacement would be comparable or similar. The EPA received support for this proposal. One commenter agrees that "[b]ecause individual tanks are likely to have comparable replacement costs, it is reasonable to assume that there would be a one-to-one correlation between the percentage of tanks being replaced at a site and the percentage of the fixed capital cost that would be required to

⁶²² EPA-HQ-OAR-2021-0317-2298.

⁶²³ EPA-HQ-OAR-2021-0317-2248.

⁶²⁴ EPA-HQ-OAR-2021-0317-2428.

construct a comparable entirely new facility.”⁶²⁵

The preamble to the December 2022 Supplemental Proposal also states that “for a tank battery which consists of more than a single storage vessel, we believe that the cost of replacing storage vessel components such as thief hatches and pressure relief devices, in comparison to the cost of constructing an entirely new storage vessel affected facility, will not exceed 50 percent of the cost of constructing a comparable new storage vessel affected facility” (87 FR 74801–02) (*emphasis added*). This statement about replacing components appears to cover replacements not addressed by the proposal above, *i.e.*, it is addressing replacements other than one-to-one storage vessel replacement in a tank battery with more than one storage vessel. However, the preamble does not provide a rationale for this statement; more importantly, the statement contradicts the EPA’s proposal to apply 40 CFR 60.15⁶²⁶ to reconstruction of a tank battery with a single storage vessel based on the contrary belief that “it may be possible that the cost of replacing the thief hatch, pressure relief device or other depreciable components could exceed 50 percent of the cost of an entirely new storage vessel.” (87 FR 74801) (*emphasis added*). The EPA solicited comment on this issue; one commenter responded that the cost of replacing the thief hatch, pressure relief device, or other depreciable components would not exceed 50 percent of the cost of an entirely new comparable tank battery, but the commenter did not provide any supporting information for its comment. Although this statement could be true where only some fraction of depreciable components (and perhaps for some fraction of the total storage vessels) in the tank battery were replaced, it remains possible that the cost of replacing the thief hatch, pressure relief device, or other depreciable components could exceed 50 percent of the cost of a comparable entirely new facility. Further, we are concerned that if we were to apply the proposed reconstruction definition for a tank battery with more than one storage vessel (*i.e.*, replacing more than 50 percent of the storage vessels in a tank battery constitutes reconstruction) and to replacements that are not one-to-one

storage vessel replacement, it could potentially have an unintended effect of disincentivizing owners and operators from replacing old storage vessels.

In light of the above, while the EPA continues to believe that it is appropriate to simplify and streamline the “reconstruction” determination where there is one-to-one storage vessel replacement in a tank battery, the EPA cannot definitively conclude that other replacements to a tank battery with more than one storage vessel would never exceed 50 percent of the cost of an entirely new storage vessel; in that respect, there is no difference between a tank battery with a single storage vessel and a tank battery with more than one storage vessel. Therefore, in the final rule, the EPA is defining “reconstruction” of a tank battery as follows:

“Reconstruction” of a tank battery occurs when the potential for VOC or methane emissions from the tank battery meets or exceeds [either the 6 tpy VOC or 20 tpy methane threshold] and either:

(A) at least half of the storage vessels are replaced in the existing tank battery that consists of more than one storage vessel; or

(B) the provisions of § 60.15 are met for the existing tank battery.

Comment: Two commenters⁶²⁷ provided input on the timeframe for determining whether a reconstruction of a tank battery had occurred. The commenter agrees that a 2-year time frame is reasonable and will provide operators with a clear way to determine if reconstruction has been triggered. Another commenter⁶²⁸ believes that a 2-year rolling period provides a reasonable method of determining whether an owner of an oil and natural gas site with storage tanks is actually pursuing an extensive tank replacement program, within the EPA’s original intent in promulgating 40 CFR 60.15.

Response: The EPA requested comment in the December 2022 Supplemental Proposal regarding the specific timeframe within which replaced storage vessels in an existing tank battery will be aggregated towards determining whether the 50 percent replacement threshold has been exceeded. As summarized above, all of the commenters consider 2 years to be a reasonable period, and one commenter specifically recommends a 2-year rolling period. The EPA is therefore finalizing a 2-year rolling period.

K. Covers and Closed Vent Systems

In section X.K of this document the final NSPS OOOOb and EG OOOOc requirements for covers and closed vent systems are summarized. Significant comments were received on the December 2022 Supplemental Proposal regarding the NIE standard. This topic, a summary of the proposed rule, the comments, the EPA responses, and changes made in the final rule (if applicable), are discussed here. These comments and the EPA’s responses to these comments generally apply to the standards proposed in both NSPS OOOOb and EG OOOOc. The instances where the comment and/or response only applies to NSPS OOOOb or EG OOOOc are noted. Comments and changes relevant to appendix K are discussed in section XIV of this preamble. The EPA’s full response to comments on the November 2021 Proposal and December 2022 Supplemental Proposal, including any comments not discussed in this preamble, can be found in the EPA’s RTC document for the final rule.⁶²⁹

In the December 2022 Supplemental Proposal, the EPA proposed a 95 percent emission reduction performance standard for a number of affected/designated facilities, including centrifugal compressor, pneumatic pump, process controller, and tank battery affected/designated facilities. This numeric standard reflects the emission reduction from capturing and routing the affected/designated facility’s emissions through a CVS to a control device with a 95 percent control efficiency, which the EPA has identified as either the BSER or a control option for these affected/designated facilities. To ensure compliance with the 95 percent emission reduction standard when using a control device,⁶³⁰ the EPA proposed that the control device must reduce the emissions routed to the control device by 95 percent or greater.⁶³¹ This would in turn require that covers and CVS be designed and operated to capture and route all emissions to the control device. To that end, the EPA proposed a NIE standard

⁶²⁹ *Standards of Performance for New, Reconstructed, and Modified Sources and Emissions Guidelines for Existing Sources: Oil and Natural Gas Sector Climate Review. Response to Public Comments on the November 2021 Proposed Rule and the December 2022 Supplemental Proposed Rule* (86 FR 63110, November 15, 2021; 87 FR 74702, December 6, 2022).

⁶³⁰ The EPA cannot require the installation of any specific control device to meet performance standards that are in the form of numeric limitation, such as the 95 percent emission reduction standard. See CAA section 111(b)(5).

⁶³¹ See proposed 40 CFR 60.5412b(a)(1)(i) and 40 CFR 60.5412c(a)(1)(i).

⁶²⁵ Cite to EDF 02/13/23 comment at 126.

⁶²⁶ 40 CFR 60.15, which defines “reconstruction” as when the cost of replacing components of an existing facility exceeds 50 percent of the cost of constructing a comparable tank battery affected facility, would require keeping accounting of the replacement costs for the “reconstruction” determination.

⁶²⁷ EPA-HQ-OAR-2021-0317-2403 and -2305.

⁶²⁸ EPA-HQ-OAR-2021-0317-2433.

for the covers and CVS associated with affected/designated facilities complying with the 95 percent emission reduction standard by routing emissions through a CVS to a control device.⁶³² Therefore, compliance with the 95 percent emission reduction standard when using a control device would require compliance with both the control device standard and the NIE standard for the associated cover and CVS. To ensure compliance with the NIE standard (which in turn would ensure compliance with the 95 percent emission reduction standard), the EPA proposed that inspections of covers and closed vent systems (except when associated with gas plants) would be conducted using AVO and either OGI or EPA Method 21, at the same frequency as inspections conducted for fugitive emissions at well sites and compressor stations. For closed vent systems at gas plants, AVO inspections would be conducted annually and OGI inspections would be conducted bimonthly in accordance with appendix K (or alternatively, quarterly using EPA Method 21).

As explained in the December 2022 Supplemental Proposal (87 FR 74805), the EPA used the term NDE in the November 2021 Proposal to describe this design and operational requirement for CVS and covers; however, in light of comments that the term NDE is closely linked with EPA Method 21 and is defined based on an instrument reading in ppmv (the proposed OGI and AVO inspections would not result in an instrument reading in ppmv), the EPA proposed renaming the standard to NIE, which is more appropriate for the methods (*i.e.*, OGI and AVO) required to demonstrate compliance. The EPA, however, emphasized that the NIE standard is an emission limitation, not a work practice standard, that any identified emissions would be a deviation of this emissions limitation, and that “the corrective actions (in the form of the repair provisions) are provided to ensure that owners and operators bring the CVS back into compliance with the NDE [now NIE] emission limit as quickly as possible.” (*Id.*) Provided below is a summary of significant comments on this topic and the EPA’s response thereto.

Comment: Commenters⁶³³ had concerns both with the term NIE and with the EPA’s position that the NIE standard is a numeric limit. One

commenter⁶³⁴ contends that there is a major difference between the terms NDE and NIE for operators, because NDE recognizes that there will be unavoidable de minimis leaks (*i.e.*, less than 500 ppmv) even in the best managed operations. Another commenter⁶³⁵ questioned the EPA’s position that the NDE standard (the term used in the November 2021 Proposal) always has been an emissions limit and that the detection of emissions above a certain threshold results in both a violation of the standard and an obligation to undertake a repair within a specified time period. The commenter explains that they are unaware of the EPA’s ever taking this position.

Regarding the numeric limit of NIE, commenters⁶³⁶ stated that the reality of engineering a “zero-emissions” standard can never be perfectly achieved. One commenter⁶³⁷ pointed out that mechanical components and seals are prone to some de minimis level of leaking despite compliance with all other requirements, and because very small leaks are unavoidable and no LDAR program can prevent leaks 100 percent of the time, operators will not be able to comply with a NIE standard. Several commenters⁶³⁸ believed that a zero-emissions standard is not realistic for equipment located outside, because the equipment is subject to harsh conditions and undergoes continuous wear and tear, including intrusion of foreign objects preventing reseating of seal surfaces. Commenters believed emissions from such scenarios should not be an indication of inadequate CVS design. One of these commenters⁶³⁹ added that such leaks are not within the control of the operator, unlike the possibility of improperly operating a cover or CVS (*e.g.*, forgetting to close a thief hatch), and asked that the EPA clearly differentiate leaks beyond the control of the operator from leaks within the control of the operator.

These same commenters offered that because the components that make up covers and CVS are exposed to the elements just as other components included in the fugitives monitoring program, it makes sense to treat them the same way, by allowing LDAR work practice standards. These commenters also questioned why a leak in a CVS pipe is considered a violation, but a leak in a gas pipeline 10 feet away is not; the

commenters believed that a leak should not be handled differently just because it occurs on a cover or CVS. From a practical standpoint, the commenters stated, leaks from these components have little to do with inadequate design or operation. One commenter⁶⁴⁰ explained that pressure and vacuum relief devices are present for safety reasons to prevent the tank from over-pressurization as well as under-pressure (*i.e.*, vacuum). The commenter noted that temperatures in North Dakota can vary 60 °F or more in a 24-hour period. This variation causes the content of the tanks to expand and shrink, and without these control devices, the commenter contended, the tanks would fail. The commenter explained that the vacuum side for the pressure relief device is especially susceptible to sucking in dust and sometimes even bugs that prevent the device from sealing, but these are all taken care of as part of the LDAR program. Finally, the commenter noted that design issues, if any, will show up as repeat offenders in the LDAR program and will be corrected as part of that program.

Another commenter⁶⁴¹ stated that the EPA does not provide anything in the rulemaking record that indicates any system capable of achieving a zero-emissions standard has been “adequately demonstrated.” The commenter contended that on its face, such a standard is therefore inconsistent with CAA section 111(a)’s plain terms and cannot be BSER. Similarly, another commenter⁶⁴² stated that the EPA long ago rejected the idea that numeric emissions limitations can or should be applied to fugitive emissions components and that the EPA has presented no reason in the proposal to depart from its historical approach regarding fugitive emissions from CVS. To this end, the commenter maintained that an NIE or NDE standard cannot constitute a numeric emissions limitation, because BSER must be achievable. The commenter further stated that CAA section 111(h)(2) provides that a work practice standard should be prescribed in lieu of a standard of performance (*i.e.*, numeric emissions limitation) when “a pollutant or pollutants cannot be emitted through a conveyance designed and constructed to emit or capture such pollutant.” The commenter contended that this is precisely the case with the EPA’s proposed NIE standards because the NIE standards do not apply to emissions

⁶³⁴ EPA-HQ-OAR-2021-0317-2391.

⁶³⁵ EPA-HQ-OAR-2021-0317-2202.

⁶³⁶ EPA-HQ-OAR-2021-0317-2202, -2248, and -2326.

⁶³⁷ EPA-HQ-OAR-2021-0317-2391.

⁶³⁸ EPA-HQ-OAR-2021-0317-2248, -2403, and -2428.

⁶³⁹ EPA-HQ-OAR-2021-0317-2428.

⁶³² See proposed 40 CFR 60.5411b(a)(3), 40 CFR 60.5416b(b), 40 CFR 60.5411c(a)(3), and 40 CFR 5416c(b).

⁶³³ EPA-HQ-OAR-2021-0317-2202, -2227, -2248, -2326, -2391, -2403, and -2428.

⁶⁴⁰ EPA-HQ-OAR-2021-0317-2248.

⁶⁴¹ EPA-HQ-OAR-2021-0317-2565.

⁶⁴² EPA-HQ-OAR-2021-0317-2428.

from the storage vessel or equipment on which the CVS is installed. Rather, the proposed NIE standard applies to the CVS itself. In this case, the commenter maintained, it is obvious that there is no “conveyance” through which the regulated pollutants would be emitted or captured. To accomplish such an outcome, the CVS to which the NIE standard applies would have to be enclosed within another CVS or similar permanent total enclosure for the regulated emissions to be captured for subsequent control or venting. According to the commenter, requiring such a system would be inordinately costly, highly impracticable, and likely impossible. The commenter pointed out that this is precisely why LDAR standards have been expressed from the inception of such programs almost exclusively as work practice standards. The commenter concluded that the NIE standard cannot be effectively construed as a zero-emissions standard, as the EPA proposes, because no “conveyance” exists that allows for capture of the regulated emissions and application of such a standard to an emissions point. The commenter stated that the EPA must make it clear that a CVS remains in compliance when a leak is detected, provided the associated work practices requiring investigation and repair are followed.

Response: As an initial matter, the EPA clarifies that CVS and covers subject to the NIE standards are not fugitive components or any other type of affected/designated facilities under NSPS OOOOb/EG OOOOc; rather, they are part of the emission control for an associated affected/designated facility (e.g., a wet seal centrifugal compressor, a pneumatic pump, process controllers, or a tank battery) that is using a control device to meet its performance standard. Accordingly, CAA section 111(h), which authorizes the EPA to prescribe work practice and other non-numeric standards for an affected/designated facility if it is not feasible to prescribe an emission limitation performance standard, does not apply to these covers and CVS.

Second, as explained in the preamble to the December 2022 Supplemental Proposal and reiterated above in this section, the NIE standard that applies to covers and closed vent systems is a numeric limitation to ensure that associated affected/designated facilities comply with the 95 percent emission reduction standard when using a control device. For example, the standard for a wet seal centrifugal compressor affected facility is to reduce emissions by 95 percent; if a control device is used, the owner or operator must equip the wet

seal fluid degassing system with a cover that routes emissions through a closed vent system to a control device (see 40 CFR 60.5380b). Since the rule allows owners and operators to use a control device with 95 percent control efficiency,⁶⁴³ compliance with the 95 percent emission reduction standard would require assurance (through demonstration) that all emissions are captured and routed via the CVS to the control device. The NIE standard reflects this compliance assurance and demonstration requirement and, for the reason explained above, is an emission limitation of zero emissions, to be demonstrated by OGI, EPA Method 21, or AVO inspection. Any identified emissions would be a deviation of the NIE standard and must be reported.⁶⁴⁴ In addition, the owner or operator must undertake the required “corrective actions” (in the form of the repair provisions) to bring the CVS back into compliance with the NIE standard as quickly as possible to ensure that the associated affected/designated facility is in compliance with the 95 percent emission reduction standard.

With respect to the comment that the “zero-emissions” NIE standard is not realistic for equipment located outside, the EPA notes that the requirement to operate the CVS or cover without emissions to the atmosphere has previously been required in NSPS OOOO and OOOOa, with compliance demonstrated by NDE. The EPA notes that the same requirement can be found in other NSPS (see, e.g., NSPS for Volatile Organic Liquid Storage Vessel, 40 CFR part 60, subpart Kb). CVS should be properly designed to minimize the possibility of leaks; for example, owners and operators should consider whether welded piping can be used in place of connectors, whether low emission equipment (such as valves) is appropriate for the CVS, which gaskets are most suitable for the composition of materials in the CVS, and whether pressure setpoints are appropriate for relief devices in the system. Owners and operators should regularly inspect and perform maintenance on the CVS to prevent equipment failure and subsequently prevent leaks from occurring.

Because the term NDE has historically been associated only with the use of

⁶⁴³ The EPA considered but declined to require the use of control devices with higher control efficiency in this rule. See discussion in section IV.H.2 of the November 2021 Proposal, 87 FR 74794 (December 6, 2022).

⁶⁴⁴ A deviation is defined as a failure to meet any obligation of the rule (including emission limits, operating limits, or work practice standards). See 40 CFR 60.5430b and 40 CFR 60.5430c.

EPA Method 21, as we explained in the December 2022 Supplemental Proposal, the EPA believes the term “no identifiable emissions” is more suited for inspections conducted by OGI and AVO.⁶⁴⁵ Contrary to the commenter’s assertion, the EPA does not believe the NIE standard using OGI is more stringent than the NDE standard using EPA Method 21. When using EPA Method 21, a leak is considered to not be detected if the monitoring instrument returns a reading below 500 ppmv (taking into account background concentration). Based on the EPA’s experience with and understanding of OGI, while it is possible to detect leaks below 500 ppmv with an OGI camera in a laboratory, it is highly unlikely that an OGI camera operator would be able to detect leaks below 500 ppmv in the conditions experienced in the field. As such, it is unlikely that owners and operators who conduct inspections of CVS and covers with OGI will regularly find leaks that would not have been required to be addressed had the owner or operator conducted the inspection with EPA Method 21. Further, where an owner or operator is concerned about the use of OGI for inspecting covers and CVS, the EPA is allowing EPA Method 21 as an alternative. Consistent with NSPS OOOO and OOOOa, emissions detected by AVO from covers and closed vent systems also are identifiable emissions. Regarding the comment that the detection of emissions above a certain threshold results in both a violation of the standard and an obligation to undertake a repair within a specified time period, the EPA believes that the repair obligations are necessary to ensure that the CVS or cover is returned to a condition of NIE as quickly as possible, which serves to limit deviations from the standard for the affected/designated facility that uses the CVS. The EPA recognizes that situations beyond the control of the owner or operator may occur, but the emission standard applies at all times.

L. Equipment Leaks at Natural Gas Processing Plants

In section X.L of this document, the final NSPS OOOOb and EG OOOOc requirements for equipment leaks at natural gas processing plants are summarized. The BSER analyses for leaks from both new and existing process unit equipment at natural gas processing plants are unchanged from what was presented in the November 2021 Proposal (see 86 FR 63231–33, section XII.G: Proposed Standards for Equipment Leaks at Natural Gas

⁶⁴⁵ 87 FR 74805 (December 6, 2022).

Processing Plants). Specifically, the EPA identified a bimonthly OGI LDAR program following appendix K that includes all equipment components that have the potential to emit VOC or methane to be BSER for both new and existing process unit equipment at natural gas processing plants. However, significant comments were received on the December 2022 Supplemental Proposal on the following topics: potential to emit methane and VOC; and the use of low-E equipment for repair. For each of these topics, a summary of the proposed rule, the comments, the EPA responses, and changes made in the final rule (if applicable), are discussed here. These comments and the EPA's responses to these comments generally apply to both NSPS OOOOb and EG OOOOc. The instances where the comment and/or response only applies to NSPS OOOOb or EG OOOOc are noted. Comments and changes relevant to appendix K are discussed in section XIV of this preamble. The EPA's full response to comments on the November 2021 Proposal and December 2022 Supplemental Proposal, including any comments not discussed in this preamble, can be found in the EPA's RTC document for the final rule.⁶⁴⁶

1. Potential To Emit Methane and VOC

In the November 2021 Proposal (86 FR 63181), the EPA proposed not to carry over to NSPS OOOOb the VOC concentration threshold in NSPS OOOOa that excludes certain equipment within a process unit from the LDAR requirements at natural gas processing plants. In NSPS OOOOa, while the affected facility included equipment that is in contact with a process fluid containing methane or VOCs, the standards only applied to equipment "in VOC service," which "means the piece of equipment contains or contacts a process fluid that is at least 10 percent VOC by weight." The EPA explained in the November 2021 Proposal that because a VOC concentration threshold has no relationship to the LDAR for methane, it is not an appropriate threshold for determining whether LDAR for methane applies. Further, the EPA explained that because there was no threshold for requiring LDAR for methane, any equipment not "in VOC service" still would be required to conduct LDAR for methane, even if not

for VOC, which made the VOC concentration threshold irrelevant.

In December 2022, the EPA proposed to apply the LDAR standards to process unit equipment that has the potential to emit methane or VOC, consistent with the November 2021 Proposal. The EPA also added provisions that each piece of equipment is presumed to emit methane or VOC unless the owner or operator demonstrates that the piece of equipment does not have the potential to emit methane or VOC. The EPA provided regulatory provisions for the demonstration, namely, that the owner or operator would have to show that the process fluid did not contain either methane or VOC.

Comment: Commenters⁶⁴⁷ on the November 2021 Proposal requested that the EPA retain the "in VOC service" requirement and 10 percent VOC by weight threshold, as well as establish a 1 percent threshold for equipment in methane service. The commenters reiterated concerns expressed in response to the November 2021 Proposal that some streams, such as acid and amine gas, ethane product streams, produced water streams, and wastewater streams should be excluded and that a 1 percent by weight methane concentration threshold would serve to exclude such streams. Otherwise, both commenters expressed concern that owners and operators would waste substantial resources to conduct LDAR monitoring on components that will always result in non-detects.

One of the commenters⁶⁴⁸ questioned the EPA's analysis in the November 2021 Proposal. The commenter states that the EPA appears to only consider components in VOC service (defined as defined as 10 percent by VOC by weight or in wet gas service) or in non-VOC service (defined as a component in methane service with at least 10 percent methane that is not also in VOC service). The commenter states that the EPA then estimates VOC and methane emissions, reductions, and cost effectiveness using a limited set of composition ratios,⁶⁴⁹ then appears to treat the "potential to emit methane" as equivalent to "in non-VOC service" in evaluating control options. Therefore, the commenter states, the EPA does not appear to fully consider the cost effectiveness of a "potential to emit" applicability threshold.

Response: The EPA is not including a VOC or methane threshold in the final rule. In response to these comments, the

EPA explained in the December 2022 Supplemental Proposal that "no additional data or analyses were provided to demonstrate that a threshold of one percent by weight methane would be appropriate. Further, recent studies indicate that produced water and wastewater streams can be significant sources of VOC and/or methane emissions" (87 FR 74808). In addition, no basis is provided for how removing "in VOC service" would substantially increase costs.

2. Low-E Technology for Repair

In the November 2021 Proposal, the EPA proposed repair requirements for leaking equipment. The EPA proposed that the definition of "repaired" (for equipment) is that the equipment is adjusted, replaced, or otherwise altered, in order to eliminate equipment leaks and that the equipment is re-monitored to verify that emissions from the equipment are below the leak definition. The EPA explained that valve repairs can include replacement with low-emissions (low-E) valves, valve packing, or drill-and-tap with a low-E injectable ("low-E equipment") but did not require replacement with low-E equipment. The EPA explained that low-E equipment meets the specifications of API 622 or API 624 and typically includes a manufacturer written warranty or a performance guarantee that it will not emit fugitive emissions at a concentration greater than 100 ppmv during the first 5 years. 86 FR 63182.

In the December 2022 Supplemental Proposal, the EPA proposed a definition of "repaired" (for equipment) consistent with that discussed in the November 2021 Proposal, and added that pumps subject to weekly visual inspections, which are designated as leaking and then repaired, are not subject to re-monitoring. The EPA did not propose to require the replacement of leaking valves with low-E equipment, noting that the technology is not appropriate for all repairs, but reiterated the position from the November 2021 Proposal that due to the performance expectations, low-E equipment can be a viable option for valve repair, as demonstrated by the re-monitoring requirements of the rule. 87 FR 74808.

Comment: Commenters⁶⁵⁰ urged the EPA to require replacement of leaking equipment with low-E valves. The commenter cited to a recent rulemaking, where Colorado found these options to be similar in cost to non-low-E valves and packing and directed operators to

⁶⁴⁶ *Standards of Performance for New, Reconstructed, and Modified Sources and Emissions Guidelines for Existing Sources: Oil and Natural Gas Sector Climate Review. Response to Public Comments on the November 2021 Proposed Rule and the December 2022 Supplemental Proposed Rule* (86 FR 63110, November 15, 2021; 87 FR 74702, December 6, 2022).

⁶⁴⁷ EPA-HQ-OAR-2021-0317-2399 and -2428.

⁶⁴⁸ EPA-HQ-OAR-2021-0317-2428.

⁶⁴⁹ The commenter (-2428) refers to Table 10-8 of the TSD. See EPA-HQ-OAR-2021-0317-0166.

⁶⁵⁰ EPA-HQ-OAR-2021-0317-2433.

consider them.⁶⁵¹ The commenter also referenced claims from some manufacturers that their low-E packing can reduce emissions of harmful gases by up to 95 percent versus valves with traditional packing, with minimal cost impacts.⁶⁵²

Response: The commenter's understanding of the cost for low-E equipment aligns with that of the EPA in that they are similar in cost to non-low-E equipment. Therefore, replacing leaking valves with low-E equipment would result in lower emissions with no additional cost burden (compared to using non-low-E equipment). However, as explained in the two proposals and reiterated above, the EPA believes that the low-E technology is not appropriate for all valve repairs, and the EPA did not receive comments disagreeing or suggesting otherwise. Therefore, the final NSPS OOOOb and the presumptive standard in EG OOOOc require replacing leaking valves with low-E valves or repacking existing valves with low-E packing, except where it is not technically feasible. If delay of repair is required to repack or replace the valve, you may use delay of repair provisionally, but no later than the next process unit shutdown. Technical infeasibility includes situations where low-E equipment is not suitable for the existing valves' intended use. Other factors that may be considered in determining technical infeasibility include: retrofit requirements for installation (*e.g.*, re-piping or space limitation), commercial unavailability for valve type, or certain instrumentation assemblies. Owners or operators are required to report annually on instances where it was infeasible to replace leaking valves with low-E valves or repack existing valves with low-E packing technology, including the reasoning for why it was infeasible.

M. Sweetening Units

In section X.M of this document the final NSPS OOOOb requirements for sweetening units are summarized. In November 2021 and December 2022, the EPA proposed to retain the standards found in NSPS OOOO and NSPS OOOOa for reducing SO₂ emissions from sweetening units. No comments were received in opposition to the December 2022 Supplemental Proposal and the standards are being finalized as proposed.

⁶⁵¹ See Colorado Air Pollution Control Division, Rebuttal Prehearing Statement, Proposed Revisions to Regulation Numbers 7 and 22 (Dec. 14–17, 2021).

⁶⁵² *Id.*

XII. Significant Comments and Changes Since Proposal for NSPS OOOOa and NSPS OOOO

As described in sections IV and VIII of the November 2021 Proposal (86 FR 63133–37, 63147–53), the 2020 Policy Rule rescinded all NSPS regulating emissions of VOC and methane from sources in the natural gas transmission and storage segment of the oil and natural gas industry and NSPS regulating methane from sources in the industry's production and processing segments. As a result, the 2020 Technical Rule only amended the VOC standards for the production and processing segments in the 2016 NSPS OOOOa, because those were the only standards that remained at the time that the 2020 Technical Rule was finalized.

Under the CRA, a rule that is subject to a joint resolution of disapproval "shall be treated as though such rule had never taken effect." 5 U.S.C. 801(f)(2). Thus, because it was disapproved under the CRA, the 2020 Policy Rule is treated as never having taken effect. As a result, the requirements in the 2012 NSPS OOOO and 2016 NSPS OOOOa that the 2020 Policy Rule repealed (*i.e.*, the VOC and methane standards for the transmission and storage segment, as well as the methane standards for the production and processing segments) must be treated as being in effect immediately upon enactment of the joint resolution on June 30, 2021. The CRA resolution did not address the 2020 Technical Rule; therefore, the amendments made in the 2020 Technical Rule, which apply only to the VOC standards for the production and processing segments in the 2016 NSPS OOOOa, have remained in effect. As a result, sources in the production and processing segments have been subject to two different sets of standards: One for methane based on the 2016 NSPS OOOOa, and one for VOC that include the amendments to the 2016 NSPS OOOOa made in the 2020 Technical Rule. Low production well sites, for example, are now subject to semiannual methane leak detection and repair requirements under the 2016 NSPS even while they continue to be exempt from leak detection and repair for VOC emissions under the 2020 Technical Rule. Such affected facilities have been able to either choose to comply with both sets of standards, which in most cases do not conflict, or to comply with the more stringent standards, which are those in the 2016 NSPS for methane. In this case, compliance with the more stringent 2016 NSPS for methane also results in compliance with the 2020 Technical

Rule. Sources in the transmission and storage segment are subject to the methane and VOC standards as promulgated in either the 2012 NSPS OOOO or the 2016 NSPS OOOOa, as applicable. In this rulemaking, the EPA updated the NSPS OOOO and NSPS OOOOa regulatory text in the CFR to reflect the CRA resolution's disapproval of the final 2020 Policy Rule, specifically, the reinstatement of the NSPS OOOO and NSPS OOOOa requirements that the 2020 Policy Rule repealed but that came back into effect immediately upon enactment of the CRA resolution. The proposed regulatory text changes for NSPS OOOO and NSPS OOOOa to reflect the CRA resolution were included in the rulemaking docket when the EPA issued the November 2021 Proposal and are being finalized as proposed.

In addition to aligning the NSPS OOOO and NSPS OOOOa regulatory text in the CFR to reflect the CRA resolution's disapproval of the final 2020 Policy Rule, the November 2021 Proposal (at 86 FR 63157–69, November 15, 2021) also included a series of proposed amendments to 2016 NSPS OOOOa for methane to align the 2016 methane standards with the current VOC standards (which were modified by the 2020 Technical Rule). Those amendments included requirements for well completions, pneumatic pumps, closed vent systems, fugitive emissions, AMEL, and onshore natural gas processing plants, along with other technical clarifications and corrections. The November 2021 Proposal preamble described the supporting rationales that were provided in the 2020 Technical Rule for modifying the requirements applicable to the VOC standards and explained why the amendments would also appropriately apply to the reinstated methane standards. Most commenters on the November 2021 Proposal provided general support for the retention of certain aspects of the 2020 Technical Rule, including the corresponding regulatory amendments to NSPS OOOOa. No significant comments were received in opposition to these proposed regulatory amendments, and they are being finalized as proposed.

Also, in the November 2021 Proposal, the EPA proposed to repeal some of the amendments that were part of the 2020 Technical Rule. Specifically, the EPA proposed to repeal its amendments in the 2020 Technical Rule that (1) exempted low production well sites from monitoring fugitive emissions and (2) changed quarterly monitoring to semiannual monitoring of VOC emissions at gathering and boosting

compressor stations. The EPA is finalizing the repeal of these amendments and subsections XII.A and B of this document discuss the comments received on the rescission of these proposed amendments and the EPA's response to those comments.

In addition to the November 2021 proposed amendments, commenters also requested changes to NSPS OOOOa that were also recommended to be made to NSPS OOOOb and EG OOOOc. These changes include allowing for delay of repair for when equipment necessary for repair is unavailable and clarifying the source category scope of the rule (*e.g.*, excludes facilities located inside and including the Local Distribution Company (LDC) custody transfer station). The EPA is making changes based on these comments in the final rule. Specifically, the EPA has revised 40 CFR 60.5397a(h)(3) to allow for a delay of repair due to the lack of availability of parts in some circumstances and has revised the introductory language at 40 CFR 60.5365a of the final rule to clarify that the Crude Oil and Natural Gas Production source category excludes facilities located inside and including the LDC custody transfer station. Section XII.C discusses the comments received and the EPA's response to comments related to delay of repair, and section XII.D discusses the comments received and the EPA's response to comments on the need to clarify the source category scope of the rule. The EPA's full response to comments on the November 2021 Proposal and December 2022 Supplemental Proposal, including any comments not discussed in this preamble, can be found in the EPA's RTC document for the final rule.⁶⁵³

A. Low Production Well Site Exemption Rescission

The EPA proposed (86 FR 63158–59) to remove the exemption of low production well sites from fugitive VOC emissions monitoring, thereby restoring the semiannual monitoring requirement established in the 2016 NSPS OOOOa.

Comment: Several commenters⁶⁵⁴ objected to the proposal to repeal the amendments in the 2020 Technical Rule that exempted low production well sites from monitoring fugitive VOC emissions under the NSPS (86 FR 63118). These

commenters urged the EPA to retain the exemption, citing concerns about the cost impacts of removing the exemption as well as objections to the EPA's emissions baseline analysis.

Commenters⁶⁵⁵ stated that the repeal of the exemption for low production well sites from monitoring fugitive emissions would result in adverse impacts to owners and operators, especially owners and operators of small-scale, independent well site operations. One of the commenters stated that the repeals of the exemption for low production well sites from monitoring fugitive emissions would affect many stripper wells in Wyoming (defined by the Wyoming Oil and Gas Conservation Commission (WOGCC) as wells that produce an average of 15 barrels of crude oil (bbl) or less per day) and some very small-scale, independent well site operations that strictly operate on a single owner's private property. According to the WOGCC, Wyoming has approximately 6,524 stripper wells. The commenter is concerned about the potential adverse economic impacts of these proposed regulations upon individual operators and the greater economy of the state of Wyoming and states that the economic impacts outweigh the indeterminate and potentially marginal environmental benefits of the proposal. The commenter added that the cost of compliance with these requirements is simply unworkable for many smaller operators in Wyoming and some operators have already expressed concerns to WDEQ that they will go out of business due to the EPA's proposed requirements. The other commenter stated that the removal of the low production well exemption would have significant detrimental impacts on their operations, costs, overhead, reserve recovery, plugging costs, and employment. The commenter noted that every increase in cost directly jeopardizes their ability to produce marginal wells.

One commenter⁶⁵⁶ suggested that removing the exemption for low-producing wells from fugitive emissions monitoring in NSPS OOOOa could result in tens of thousands of additional affected facilities and/or projects establishing PTE below affected source emissions levels. The commenter added that changing this requirement may also result in some facilities becoming an affected facility retroactively.

Another commenter⁶⁵⁷ recommended that the EPA consider the small, low-emitting nature of Pennsylvania and

New York conventional oil and gas production before imposing any additional requirements in the NSPS OOOOa (and NSPS OOOOb and EG OOOOc) revisions.

A couple of commenters⁶⁵⁸ also requested that the EPA more thoroughly evaluate emissions and costs of control of marginal/low production well sites. One of the commenters requested that the EPA first determine if marginal well emissions warrant regulation. The commenter noted that the DOE was conducting a study to better characterize emissions from these types of wells. The commenter stated that E.O. 13990 requires the Federal Government, “. . . be guided by the best science and be protected by processes that ensure the integrity of Federal decision-making.” As such, the commenter recommended that the EPA defer regulating marginal/low production wells until the DOE report was available for review or collect additional data to fully determine the emissions profile of these types of wells, determine if requirements are needed, and if needed, develop an appropriate regulatory program. Similarly, the other commenter suggested that they are aware of at least one study underway to evaluate methane emissions from marginal wells, and that there may be others. The commenter contends that, if the study's findings demonstrate that these methane emissions contributions from low production well sites do not contribute in any significant manner, the commenter expressed that it is imperative that the EPA consider these findings and provide appropriate exemptions.

One commenter⁶⁵⁹ stated that marginal wells are not a significant source of methane and that emissions from a well are proportionate to the volume of oil and/or gas produced. As a result, the commenter stated that marginal wells produce significantly fewer emissions because they are marginal producers of oil and gas. According to the commenter, emissions from their wells are much lower than those emitted from high volume wells produced by larger companies. The commenter expressed that it is unfair and unwise to treat small operators with marginal wells in the same manner as larger producers. The commenter suggested that marginally producing wells be exempt from the EPA rules because the emissions are insignificant, and the rules would be uneconomic. The commenter further requested that

⁶⁵³ *Standards of Performance for New, Reconstructed, and Modified Sources and Emissions Guidelines for Existing Sources: Oil and Natural Gas Sector Climate Review. Response to Public Comments on the November 2021 Proposed Rule and the December 2022 Supplemental Proposed Rule* (86 FR 63110, November 15, 2021; 87 FR 74702, December 6, 2022).

⁶⁵⁴ EPA-HQ-OAR-2021-0317-0577, -0803, -0824, and -0464.

⁶⁵⁵ EPA-HQ-OAR-2021-0317-0464 and -0824.

⁶⁵⁶ EPA-HQ-OAR-2021-0317-0763.

⁶⁵⁷ EPA-HQ-OAR-2021-0317-1341.

⁶⁵⁸ EPA-HQ-OAR-2021-0317-0810 and -0824.

⁶⁵⁹ EPA-HQ-OAR-2021-0317-0464.

there be a regulatory “off ramp” for low-producing wells such as theirs.

Response: As discussed in the December 2022 Supplemental Proposal, the EPA solicited comment in the November 2021 Proposal on regulatory alternatives and additional information that would warrant considering a subset of sites differently based on a potentially different emissions profile, production levels, equipment onsite, or other factors. The EPA examined data provided through an ICR distributed in 2016, data provided on equipment/component counts in relation to the October 15, 2018, proposed reconsideration of NSPS OOOOa from independent producers (many of whom are small businesses), data provided through comments on the November 2021 Proposal from independent producers, and data contained in the U.S. DOE marginal well study to determine if a subset of well sites with major production and processing equipment should be considered differently.

Consistent with comments received on previous rulemakings, the EPA received comments on the November 2021 Proposal expressing that emissions from a well are proportionate to the volume of oil and/or gas produced.⁶⁶⁰ Commenters also referenced the U.S. DOE marginal well study. However, the U.S. DOE marginal well study (now available) concludes that the frequency and magnitude of emissions from well sites are more strongly correlated with equipment counts, not production rates.⁶⁶¹ Further, this study broke down emissions by site size and production levels and found that the smallest emissions rates were from the second production level bin (2 barrels of oil equivalent per day (boe/day) to 6 boe/day) and not the lowest-producing sites (production less than 2 boe/day). Another study issued in April 2022 by

⁶⁶⁰ See Document ID No. EPA-HQ-OAR-2021-0317-0464.

⁶⁶¹ Section 5.2.1 of the study concludes, “The correlation between major equipment counts and site emission frequency (expressed as the number of detected emissions per piece of major equipment, *i.e.*, not absolute count of emissions), was strong with the categorical site ‘size’ variable and moderate (positive) with the numeric equipment count. Among evaluated numeric variables, site equipment counts also exhibited the strongest associations with both frequency and magnitude of site-wide emissions, exhibiting only a moderate positive correlation with detection frequency and weak associations with whole gas and methane emission rates. Weak correlations were also consistently detected among both the frequency and magnitude of emissions, total oil and gas production, and gas production rates.” See Bowers, Richard L. Quantification of Methane Emissions from Marginal (Low Production Rate) Oil and Natural Gas Wells. <https://www.osti.gov/biblio/1865859>. page 19.

Omara, *et al.*, concludes that approximately half of the methane emissions emitted from well sites in the U.S. comes from low production well sites (defined in that study as 15 boe/day or less production rates).^{662 663} However, the EPA notes that this study is not limited to fugitive emissions, and the overall impacts on emissions reductions achieved under NSPS OOOOa (and NSPS OOOOb and EG OOOOc) if these rules are finalized as proposed, would target the emissions reported in that study as a whole. Therefore, the EPA does not have compelling information that suggests production levels should provide the basis for consideration of different fugitive emissions requirements for well sites.

As stated in the November 2021 Proposal, the EPA remains mindful about how the fugitive emissions monitoring requirements will affect small businesses. The EPA discusses the financial conditions of marginal wells in chapter 6 of the final rule TSD. There are many factors that might affect the profitability of marginal wells and the decision to shut in and plug a well, making it difficult to determine the full impact of regulation on the financial status of marginal well owners. The EPA has also taken steps to include regulatory flexibility and streamline recordkeeping requirements in the fugitive emissions standards of NSPS OOOOa.

The EPA is therefore finalizing the proposed (86 FR 63158–59) removal of the exemption of low production well sites from fugitive VOC emissions monitoring, thereby restoring the semiannual monitoring requirement established in the 2016 NSPS OOOOa.

B. Compressor Station Quarterly Monitoring

The EPA proposed to repeal its amendment to the VOC monitoring frequency for gathering and boosting compressor stations in the 2020 Technical Rule because the EPA believed that amendment was made in error. 86 FR 63159

Comment: Some commenters⁶⁶⁴ expressed opposition to the proposal

⁶⁶² Omara, M., Zavala-Araiza, D., Lyon, D.R., *et al.* Methane emissions from US low production oil and natural gas well sites. *Nat Commun* 13, 2085 (2022). <https://doi.org/10.1038/s41467-022-29709-3>.

⁶⁶³ The EPA notes that Omara, *et al.*, analyzed data from offsite measurements of methane emissions from well sites. These measurements would include methane from any leak, venting, flaring, or other source onsite and, therefore, conclusions from this study cannot be directly applied to the specific fugitive sources covered by this action.

⁶⁶⁴ EPA-HQ-OAR-2021-0317-0755 and -0923.

and requested that fugitive emissions monitoring at compressor stations only be required on a semiannual basis. One commenter contended that a requirement for more frequent monitoring would be unduly burdensome, given that one pipeline system could have numerous compressor stations that are often located in remote areas. In addition, the commenter stated that the resources (both personnel and equipment) to comply with survey requirements may be limited, a concern that the commenter says that the EPA itself acknowledged in the preamble for the initial NSPS OOOOa Proposal. Moreover, the commenter stated that the leak rate in the gathering and boosting industry segment is particularly low. The commenter urged the EPA to retain the current requirement of semiannual monitoring for fugitive emissions at compressor stations, including gathering and boosting compressor stations. Similarly, another commenter suggested that it is overly burdensome to require quarterly compressor monitoring in respect to surveys and recordkeeping. The commenter noted that the value of increased monitoring to reduce small amounts of methane and VOC does not offset the associated expense and manpower required to fulfill the proposed regulations. The commenter suggested that a baseline for compressor stations could be undertaken as a similar proposal for less than 3 tpy well sites to determine future requirements of a particular site.

Another commenter⁶⁶⁵ also suggested that changing the monitoring frequency for the transmission and storage segments from semiannual to quarterly creates confusion with the other actions taken in 2021 regarding NSPS OOOOa as these facilities have transferred back and forth between affected facility status due to policy changes within the existing NSPS OOOOa.

Response: As stated in the December 2022 Supplemental Proposal, the analyses the EPA conducted for NSPS OOOOb and EG OOOOc confirm that quarterly monitoring remains both achievable and cost-effective for compressor stations, and several state agencies have rules that require quarterly monitoring at compressor stations. The cost analysis conducted for the November 2021 Proposal was a comprehensive evaluation of emissions, reductions, and costs associated with various leak detection and repair programs, which firmly established that the cost effectiveness of quarterly monitoring for compressor stations is

⁶⁶⁵ EPA-HQ-OAR-2021-0317-0763.

reasonable. The November 2021 Proposal established that BSER for reducing methane and VOC emissions from all compressor stations, including gathering and boosting stations, transmission stations, and storage stations was quarterly monitoring. In the December 2022 Supplemental Proposal, the EPA retained the proposed quarterly OGI (or EPA Method 21) monitoring requirement for fugitive emissions components affected facilities located at compressor stations. Although some commenters oppose quarterly monitoring, they express no disagreement with EPA's BSER analysis; rather, they find quarterly monitoring unnecessarily burdensome or may cause confusion after allowing semi-annual monitoring in the 2020 amendment, none of which are reasons for the EPA not to restore the monitoring frequency that reflects the BSER. Therefore, based on the reasoning provided in the November 2021 Proposal that the EPA lacked justification and erred in revising the VOC monitoring frequency for gathering and boosting compressor stations from quarterly to semiannual and that the cost effectiveness of quarterly monitoring for compressor stations is reasonable, the EPA is finalizing the restoration of the quarterly monitoring requirement for gathering and boosting compressor stations, as established in the 2016 NSPS OOOOa.

C. Delay-of-Repair Provisions

Comment: Some commenters requested changes to NSPS OOOOa that were also recommended to be made to NSPS OOOOb and EG OOOOc. One of those requested changes was to allow for a delay of repair when parts are unavailable to do the required repairs. One commenter⁶⁶⁶ supported reconciling NSPS OOOOa delay-of-repair regulatory text consistent with the 2020 Technical Rule. However, the commenter also recommended that the delay-of-repair text be amended to address the delay necessary when parts are unavailable, an issue that they believe is especially important for existing sources. The comments summarized in section XI.A.2.b were generally intended for NSPS OOOOa as well as NSPS OOOOb and EG OOOOc.

Response: Based on these comments, the EPA is amending 40 CFR 60.5397a(h)(3) to allow the delay of repairs due to the lack of availability of parts with provisions identical to those of NSPS OOOOb and EG OOOOc. NSPS OOOOa has been revised to allow for delay of repair due to unavailability of parts if replacement parts are necessary

and cannot be acquired within the repair timeline if either replacement part supplies had been sufficiently stocked before the supplies were depleted or a replacement part requires custom fabrication. Replacement parts must be ordered within 10 calendar days after the first attempt at repair. The repair must be completed within 30 calendar days after receipt of the replacement parts or during the next scheduled shutdown for maintenance after the parts are received (if the repair requires a shutdown). As the EPA was considering provisions allowing for delay of repair due to parts unavailability for sources regulated under NSPS OOOOb and EG OOOOc, the EPA found that the supplemental information submitted and reasoning for allowing delay of repair due to parts unavailability under NSPS OOOOb and EG OOOOc is equally applicable to sources regulated under NSPS OOOOa and, for that reason, is also including the provision in 40 CFR 60.5397a(h)(3).

D. Applicability/Scope of the Rule

Comment: As noted above, some commenters requested changes to NSPS OOOOa that were also recommended to be made to NSPS OOOOb and EG OOOOc. One of those requested changes was to add greater clarity regarding the applicability/scope of the rule.

One commenter⁶⁶⁷ stated that because their members are small without access to significant resources to fully analyze complex rulemakings, it is important that the scope of the rule be made as clear as possible. The commenter requested that the EPA include the following underlined text in NSPS OOOOa at 40 CFR 60.5365a and in appropriate, corresponding sections of NSPS OOOOb and EG OOOOc (underlined text reflects their recommended additions):

§ 60.5365a Am I subject to this subpart?

You are subject to the applicable provisions of this subpart if you are the owner or operator of one or more of the onshore affected facilities listed in paragraphs (a) through (j) of this section, *that is located within the Crude Oil and Natural Gas Production source category, as defined in § 60.5430, for which you commence construction, modification, or reconstruction.*

Similarly, another commenter⁶⁶⁸ stated that a small gas utility or cooperative that does not have an environmental lawyer on staff may not understand that the rule applies only to facilities that are located within the

Crude Oil and Natural Gas Production source category as defined in 40 CFR 60.5430a, and that they need to refer to the definitions section toward the end of the rule to discover that the source category does not include operations inside and including the LDC custody transfer station, and that the subpart only applies to facilities in the defined source category. The commenter stated that clarifying language was added to 40 CFR 60.5365a in the 2020 Policy Rule.⁶⁶⁹ At a minimum, the commenter suggested that similar language be restored in NSPS OOOOa and included in the new scope provisions of NSPS OOOOb and EG OOOOc to clarify that facilities inside and including the LDC custody transfer station are not subject to the subpart. The commenter urged the EPA to include the following text in 40 CFR 60.5365a and in the analogous scope sections of NSPS OOOOb and EG OOOOc:

You are subject to the applicable provisions of this subpart if you are the owner or operator of one or more of the onshore affected facilities listed in paragraphs (a) through (j) of this section, that is located within the Crude Oil and Natural Gas Production source category, as defined in § 60.5430a. Facilities located inside and including the LDC custody transfer station are not subject to this subpart.

Response: The EPA considered the comments provided and agrees that, while the definitions section clearly defines the boundaries of the source category, additional clarification in the applicability section of the subpart, with respect to LDC custody transfer, would further assist sources in identifying whether they are subject to any of the requirements in NSPS OOOOa. Therefore, the final rule includes the following introductory language at 40 CFR 60.5365a:

You are subject to the applicable provisions of this subpart if you are the owner or operator of one or more of the onshore affected facilities listed in paragraphs (a) through (j) of this section, that is located within the Crude Oil and Natural Gas Production source category, as defined in § 60.5430a, for which you commence construction, modification, or reconstruction after September 18, 2015, and on or before December 6, 2022. Facilities located inside and including the Local Distribution Company (LDC) custody transfer station are not subject to this subpart.

⁶⁶⁶ EPA-HQ-OAR-2021-0317-0782.

⁶⁶⁷ EPA-HQ-OAR-2021-0317-0928.

⁶⁶⁸ EPA-HQ-OAR-2021-0317-0815.

⁶⁶⁹ 85 FR 57029-30, September 14, 2020.

XIII. Significant Comments and Changes to Emission Guidelines for State, Tribal, and Federal Plan Development for Existing Sources

A. Overview

In the December 2022 Supplemental Proposal, the EPA proposed adjustments from the November 2021 Proposal, and additional requirements to provide states with information needed for purposes of state plan development. In the following sections of this preamble, in the same six-part organizational ordering as the December 2022 Supplemental Proposal, we summarize significant comments and changes since the December 2022 Supplemental Proposal for purposes of the final EG. We also discuss the interaction of these final EG with recently finalized revisions to the CAA section 111(d) implementing regulations, 40 CFR part 60 subpart Ba (subpart Ba).⁶⁷⁰ The EPA proposed these EG in accordance with the version of subpart Ba that existed at the time of proposal. However, since the recent revisions to subpart Ba are now final and are therefore applicable to these EG, the final version of these EG comports with the revised version of subpart Ba. Further, states developing plans in accordance with EG OOOOc must follow the recently revised version of subpart Ba, except where these EG expressly supersede the requirements of subpart Ba. The EPA discusses the importance of these changes in more detail later in this preamble.

First, we discuss components of the final EG. Second, we discuss the requirements for establishing standards of performance in state plans. Third, we discuss the components of an approvable state plan submission. Fourth, we discuss the final timing for state plan submissions, and final timeline for designated facilities to come into final compliance with the state plan. Fifth, we discuss the EPA's action on state plans and the promulgation of Federal Plans. Sixth, we discuss Tribes and the planning process for Tribal plans under CAA section 111(d).

B. Components of EG

As explained in the November 2021 Proposal, CAA sections 111(d)(1) and 111(a)(1) collectively establish and define certain roles and responsibilities for the EPA and the states. The EPA addresses its responsibilities by drafting and publishing EG in accordance with 40 CFR 60.22a, which “[contain] information pertinent to control of the designated pollutant from designated

facilities.” Mirroring language included in CAA section 111(d)(1), the EPA's implementing regulations define a designated pollutant as “any air pollutant, the emissions of which are subject to a standard of performance for new stationary sources, but for which air quality criteria have not been issued and that is not included on a list published under section 108(a) or section 112(b)(1)(A) of the Act.” 40 CFR 60.21a(a). The EPA's implementing regulations also define a designated facility as “any existing facility (see § 60.2) which emits a designated pollutant, and which would be subject to a standard of performance for that pollutant if the existing facility were an affected facility (see § 60.2).” *Id.* at § 60.21a(b). The designated pollutant for purposes of the final EG OOOOc included in this rulemaking is GHGs, but the presumptive standards in the EG are expressed in terms of limitations on methane. A description of each of the designated facilities included in the final EG OOOOc can be found in sections X and XI of this preamble.

More specifically, 40 CFR 60.22a(b) lists six components to be included in EG to provide information for development of the state plans triggered by the promulgation of the EG. Within the November 2021 Proposal, the EPA explained how the proposed EG OOOOc satisfied these regulatory requirements. 86 FR 63110, 63248–49 (November 15, 2021). Within the December 2022 Supplemental Proposal, the EPA elaborated on several of these components. 87 FR 74702, 74816 and 74834 (December 6, 2022). The recent revisions to subpart Ba did not alter 60.22a(b) in any meaningful way, so the analysis provided in the proposals remains relevant and satisfactory. In addition, the EPA has included information in this final rulemaking action that updates and supplements that analysis. First, the EG must include information regarding the “endangerment of public health or welfare caused, or contributed to, by the designated pollutant.” 40 CFR 60.22a(b)(1). Information on the harmful public health and welfare impacts of GHG (methane) emissions from the oil and natural gas industry were included in the November 2021 Proposal⁶⁷¹ and are updated above in section III of this document. Second, the EG must include a “description of systems of emission reduction which, in the judgment of the Administrator, have been adequately demonstrated.” 40 CFR 60.22a(b)(2). The EPA has included such a description in the November 2021

Proposal,⁶⁷² in the November 2021 TSD,⁶⁷³ in the December 2022 Supplemental Proposal,⁶⁷⁴ in the December 2022 TSD,⁶⁷⁵ in sections X and XI of this preamble, and in the final TSD located at Docket ID No. EPA–HQ–OAR–2021–0317. Third, the EG must include information regarding “the degree of emission limitation” achievable through application of each system, along with information “on the costs, nonair quality health and environmental effects, and energy requirements of applying each system to designated facilities.” *Id.* at 60.22a(b)(3). The EPA has included such a description in the November 2021 Proposal,⁶⁷⁶ in the November 2021 TSD,⁶⁷⁷ in the December 2022 Supplemental Proposal,⁶⁷⁸ in the December 2022 TSD,⁶⁷⁹ in sections X and XI of this preamble, and in the final TSD located at Docket ID No. EPA–HQ–OAR–2021–0317. Fourth, the EG must include information regarding the amount of time that the EPA believes would be normally necessary for designated facilities to design, install, and startup the control systems identified in component number three. See *Id.* at 60.22a(b)(4). The EPA proposed how to address this component in both the November 2021 Proposal and the December 2022 Supplemental Proposal and finalizes its explanation of how to address this component in section XIII.E of this document. Fifth, and likely most helpful to states when developing their plans, the EG must include information regarding the “degree of emission limitation achievable through the application of the best system of emission reduction” that has been adequately demonstrated, taking into account the same factors as described in component three (cost, nonair quality health and environmental impact and energy requirements), “and the time within which compliance with standards of performance can be achieved.” *Id.* at 60.22a(b)(5). The EPA has included such information in the November 2021 Proposal;⁶⁸⁰ in the November 2021 TSD;⁶⁸¹ in the December 2022 Supplemental Proposal;⁶⁸² in the December 2022

⁶⁷² 86 FR 63169–63240 (November 15, 2021).

⁶⁷³ EPA–HQ–OAR–2021–0317–0166.

⁶⁷⁴ 87 FR 74722–810 (December 6, 2022).

⁶⁷⁵ EPA–HQ–OAR–2021–0317–1578.

⁶⁷⁶ 86 FR 63169–240 (November 15, 2021).

⁶⁷⁷ EPA–HQ–OAR–2021–0317–0166.

⁶⁷⁸ 87 FR 74722–810 (December 6, 2022).

⁶⁷⁹ EPA–HQ–OAR–2021–0317–1578.

⁶⁸⁰ 86 FR 63169–240 (November 15, 2021).

⁶⁸¹ EPA–HQ–OAR–2021–0317–0166.

⁶⁸² 87 FR 74722–810 (December 6, 2022).

⁶⁷⁰ 88 FR 80480 (November 17, 2023).

⁶⁷¹ 86 FR 63124 (November 15, 2021).

TSD;⁶⁸³ in sections X, XI, and XIII.E of this preamble; and in the final TSD located at Docket ID No. EPA–HQ–OAR–2021–0317. In identifying the degree of achievable emission limitation, the EPA may subcategorize, that is to “specify different degrees of emission limitation or compliance times or both for different sizes, types, and classes of designated facilities when costs of control, physical limitations, geographical location, or similar factors make subcategorization appropriate.” *Id.* The EPA has chosen to exercise that discretion to subcategorize within the final EG for certain designated facilities.⁶⁸⁴ Sixth, and last, the EG is to include any other information not contemplated by the five other components that the EPA “determines may contribute to the formulation of State plans.” *Id.* at 60.22a(b)(6). Section XIII of this preamble includes such information and guidance specifically designed to assist states in developing and submitting their plans under CAA 111(d) for the final EG OOOOc.

C. Establishing Standards of Performance in State Plans

After the EPA provides information regarding the BSER in this final EG, as described in preamble section XII of the November 2021 Proposal and preamble section IV of the December 2022 Supplemental Proposal, each state that has a designated facility located within the state must develop, adopt, and submit to the EPA its state plan under CAA section 111(d). The state plan must include standards of performance for all designated facilities. Under the TAR adopted by the EPA, Tribes may seek

authority to implement a plan under CAA section 111(d) in a manner similar to a state. See 40 CFR part 49, subpart A. Tribes may, but are not required to, seek approval for treatment in a manner similar to a state for purposes of developing a TIP implementing the EG. The final EG OOOOc addresses two key aspects of implementation, among other issues: establishing standards of performance for designated facilities and providing measures that implement and enforce such standards. In this final EG, based on changes as a result of public comments, the EPA finalizes updates to certain presumptive standards included in the December 2022 Supplemental Proposal, and finalizes regulations related to state flexibilities, certain implementation and enforcement measures, and emissions inventories. The EPA is not finalizing in EG OOOOc the proposed requirements related to meaningful engagement with pertinent stakeholders, and electronic submittal of state plans, nor it is finalizing certain proposed requirements related to the application of a standard of performance to a particular designated facility that is less stringent than otherwise required by the EG when taking into consideration the facility’s RULOF because such regulations are no longer needed in this EG (OOOOc). Via a separate rulemaking process, the EPA has finalized revisions to subpart Ba⁶⁸⁵ addressing the framework for less stringent standards of performance pursuant to RULOF, meaningful engagement with pertinent stakeholders, and electronic submittal of state plans which are applicable to states developing plans under these EG.

Since these issues are addressed in the final revisions to subpart Ba, and subpart Ba applies to states developing plans under this EG (OOOOc), it would be redundant for the EPA to also finalize the same provisions related to these issues within EG OOOOc. As such, the EPA is not finalizing provisions specific to these issues as proposed in the context of this EG (OOOOc) and is instead deferring to subpart Ba on these issues. States should carefully review the recent revisions to subpart Ba since subpart Ba applies to state plans developed in accordance with this EG, except to the extent that this EG supersedes subpart Ba (such as, for emissions inventories and the deadline for state plan submittals, discussed in later sections).

1. Establish Standards of Performance for Designated Facilities

As stated in the November 2021 Proposal, and reiterated in the December 2022 Supplemental Proposal, the EPA’s proposed EG OOOOc included information on the degree of emissions limitation achievable through application of the BSER in the form of presumptive standards for designated facilities.⁶⁸⁶ The EPA described that there is a fundamental requirement under CAA section 111(d) that a state’s standards of performance in its state plan submittal are no less stringent than the presumptive standard determined by the EPA, which derives from the definition of “standard of performance” in CAA section 111(a)(1).⁶⁸⁷ The EPA is updating tables 25 and 26 to reflect the final presumptive standards in the final EG OOOOc.

TABLE 25—SUMMARY OF FINAL EG SUBPART OOOOc PRESUMPTIVE NUMERICAL STANDARDS

Designated facility	Final presumptive numerical standards in the emissions guidelines for GHGs
Storage Vessels: Tank Battery with PTE of 20 tpy or more of methane	95 percent reduction of methane.
Process Controllers: Natural gas-driven	Methane emissions rate of zero.
Pumps: Natural gas-driven	Methane emissions rate of zero.

TABLE 26—SUMMARY OF FINAL EG SUBPART OOOOc PRESUMPTIVE NON-NUMERICAL STANDARDS

Designated facility	Final presumptive non-numerical standards in the emissions guidelines for GHGs ⁶⁸⁸
Fugitive Emissions: Single Wellhead Only Well Sites and Small Well Sites.	Quarterly AVO monitoring surveys. First attempt at repair within 15 days after detecting fugitive emissions. Final repair within 15 days after first attempt. Fugitive monitoring continues for all well sites until the site has been closed, including plugging the wells at the site and submitting a well closure report.

⁶⁸³ EPA–HQ–OAR–2021–0317–1578.

⁶⁸⁴ See sections X and XI of this preamble for detailed discussion of the designated facilities for which the EPA is including subcategories for.

⁶⁸⁵ 88 FR 80480 (November 17, 2023).

⁶⁸⁶ 86 FR 63169–63240 (November 15, 2021) and 87 FR 74722–810 (December 6, 2022).

⁶⁸⁷ CAA section 111(d)(1) also provides that states may apply less stringent standards of performance to particular sources based on consideration of such sources’ remaining useful life and other factors.

TABLE 26—SUMMARY OF FINAL EG SUBPART OOOOc PRESUMPTIVE NON-NUMERICAL STANDARDS—Continued

Designated facility	Final presumptive non-numerical standards in the emissions guidelines for GHGs ⁶⁸⁸
Fugitive Emissions: Multi-wellhead only Well Sites (2 or more wellheads).	Quarterly AVO monitoring surveys. First attempt at repair within 15 days after detecting fugitive emissions. Final repair within 15 days after first attempt. Semiannual OGI monitoring (Optional semiannual EPA Method 21 monitoring with 500 ppm defined as a leak). First attempt at repair within 30 days after detecting fugitive emissions. Final repair within 30 days after first attempt. Fugitive monitoring continues for all well sites until the site has been closed, including plugging the wells at the site and submitting a well closure report.
Fugitive Emissions: Well Sites and Centralized Production Facilities.	Bimonthly AVO monitoring surveys. First attempt at repair within 15 days after detecting fugitive emissions. Final repair within 15 days after first attempt. Quarterly OGI monitoring. (Optional quarterly EPA Method 21 monitoring with 500 ppm defined as a leak). First attempt at repair within 30 days after detecting fugitive emissions. Final repair within 30 days after first attempt. Fugitive monitoring continues for all well sites until the site has been closed, including plugging the wells at the site and submitting a well closure report.
Fugitive Emissions: Compressor Stations	Monthly AVO monitoring surveys. First attempt at repair within 15 days after detecting fugitive emissions. Final repair within 15 days after first attempt. AND Quarterly OGI monitoring. (Optional quarterly EPA Method 21 monitoring with 500 ppm defined as a leak). First attempt at repair within 30 days after detecting fugitive emissions. Final repair within 30 days after first attempt.
Fugitive Emissions: Well Sites and Compressor Stations on Alaska North Slope.	Annual OGI monitoring. (Optional annual EPA Method 21 monitoring with 500 ppm defined as a leak). First attempt at repair within 30 days after detecting fugitive emissions. Final repair within 30 days after first attempt.
Process Controllers: Alaska (at sites where on-site power is not available—continuous bleed natural gas-driven).	Natural gas bleed rate no greater than 6 scfh.
Process Controllers: Alaska (at sites where on-site power is not available—intermittent natural gas-driven).	OGI monitoring and repair of emissions from controller malfunctions.
Pumps: Natural gas-driven (at sites where on-site power is not available and there are fewer than 3 diaphragm pumps).	Route pump emissions to a process if VRU is onsite, or to control device if onsite.
Gas Well Liquids Unloading	Employ best management practices to minimize or eliminate venting of emissions to the maximum extent possible. LDAR with OGI following procedures in appendix K.
Equipment Leaks at Natural Gas. Processing Plants.	Route associated gas to a sales line. Alternatively, the gas can be used as an onsite fuel source or used for another useful purpose that a purchased fuel or raw material would serve or be injected into the well or another well. If demonstrated, and annually documented, that a sales line and alternatives are not technically feasible, the gas can be routed to a flare or other control device that achieves at least 95 percent reduction in methane emissions.
Oil Wells with greater than 40 tpy of Associated Methane Gas.	Route associated gas to a sales line. Alternatively, the gas can be used as an onsite fuel source or used for another useful purpose that a purchased fuel or raw material would serve, or be injected into the well or another well. Alternatively, the gas can be routed to a flare or other control device that achieves at least 95 percent reduction in methane emissions.
Oil Wells with 40 tpy or less of Associated Methane Gas.	Monitoring and repair to maintain volumetric flow rate at or below 3 scfm per compressor seal.
Wet Seal Centrifugal Compressors (except for those located at well sites): Includes self-contained wet seal centrifugal compressors and centrifugal compressors equipped with mechanical seals.	Monitoring and repair to maintain volumetric flow rate at or below 9 scfm per seal.
Wet Seal Centrifugal Compressors (except for those located at well sites): Alaska North Slope centrifugal compressors equipped with a seal oil recovery system.	Monitoring and repair to maintain volumetric flow rate at or below 10 scfm per compressor seal.
Dry Seal Centrifugal Compressors (except for those located at well sites).	Monitoring and repair to maintain volumetric flow rate at or below 2 scfm per compressor cylinder.
Reciprocating Compressors (except for those located at well sites).	

¹ Fugitive Emissions: Well Sites, Centralized Production Facilities, and Compressor Stations: (Optional) Alternative periodic screening with advanced measurement technology instead of OGI monitoring.

² Fugitive Emissions: Well Sites, Centralized Production Facilities, and Compressor Stations: (Optional) Alternative continuous monitoring system instead of OGI monitoring.

The EPA received comments regarding the proposed presumptive standards. A summary of some comments received and the EPA's response to these comments, including any changes made to the final rule, as applicable, are provided below. The EPA's full response to comments on the

November 2021 Proposal and December 2022 Supplemental Proposal, including any comments not discussed in this preamble, can be found in the EPA's RTC document for the final rule.⁶⁸⁹

⁶⁸⁸ For fugitive emissions at well sites, centralized production facilities, and compressor stations, the

final EG includes an advanced measurement technology compliance option to use alternative periodic screening and alternative continuous monitoring instead of OGI and AVO monitoring.

⁶⁸⁹ *Standards of Performance for New, Reconstructed, and Modified Sources and Emissions Guidelines for Existing Sources: Oil and Natural Gas Sector Climate Review. Response to Public Comments on the November 2021 Proposed*

Comment: The EPA received numerous comments that seem to object to the general notion that a presumptive standard included in the EG can be the same as a standard of performance under the NSPS. Commenters contend that the EPA did not perform an appropriate BSER analysis for existing sources and cannot simply apply the new source BSER to existing sources without further explanation. Some commenters state that EG OOOOc requirements should not be same as NSPS OOOOb requirements, and that the cost of regulations for existing sources is significantly higher than on new facilities, especially where there is significant capital cost.

Response: In accordance with section 111(d) of the Clean Air Act (CAA), states are tasked with developing plans which establish standards of performance for existing sources. Further, in accordance with CAA 111(d) and the EPA's implementing regulations, the EPA is to publish EG for certain sources. Those guidelines are to include certain information including "[t]he degree of emission limitation achievable through the application of the best system of emission reduction (considering the cost of such achieving reduction and any nonair quality health and environmental impact and energy requirements) that has been adequately demonstrated for designated facilities." 40 CFR 60.22a(b)(5). The EG must also include: "[i]nformation on the degree of emission limitation which is achievable with each system, together with information on the costs, nonair quality health environmental effects, and energy requirements of applying each system to designated facilities." *Id.* at 60.22a(b)(3).

The EPA is finalizing EG that translate the degree of emission limitation achievable through application of the BSER (*i.e.*, level of stringency) into presumptive standards of performance that states may use in the development of state plans for specific emission points. The EPA's final EG do not impose binding requirements directly on sources, but instead provide requirements for states in developing their plans and criteria for assisting the EPA when judging the adequacy of such plans. The presumptive standards that commenters appear to take issue with are a product of the EPA's compliance with the CAA and its own regulations, and are intended to assist states with the development of their plans.

Within the EPA's November 2021 Proposal, the Agency explained why the

EG's proposed presumptive standards were often very similar to, if not exactly the same as, the EPA's proposed standards of performance under the proposed NSPS OOOOb. Part of that explanation is copied here for context:

As discussed in each of the EG-specific subsections below, the EPA's evaluation of BSER in the context of existing sources utilized much of the same information as our BSER analysis for the NSPS. This is because within the oil and natural gas industry many of the control measures that are available to reduce emissions of methane from existing sources are the same as those control measures available to reduce VOC and methane emissions from new, modified, and reconstructed sources. By extension, many of the methane emission reductions achieved by the available control options, as well as the associated costs, nonair environmental impacts, energy impacts, and limitations to their application, are very similar if not the same for new and existing sources. Any relevant differences between new and existing sources in the context of available control measures or any other factors are discussed in the EG-specific subsections below.

86 FR 63186.

The November 2021 Proposal goes on to elaborate on these general concepts. *Id.* The subsections that follow then explain the similarities and any differences between new and existing sources for each of the designated facilities covered by the EG. The December 2022 Supplemental Proposal took the same approach by identifying similarities and differences between new and existing sources, when relevant, within the sections discussing the different affected and designated facilities.

Commenters provide no rationale or explanation to support the general assertion that the presumptive standards in this EG cannot ever be the same as the standards of performance in the corresponding NSPS. Nor does any relevant CAA authority prohibit this outcome. The EPA did not simply copy the NSPS into the EG. As explained in the November 2021 Proposal, the analysis that the EPA undertakes for purposes of the EG OOOOc is the same as the analysis that the agency undertakes for the NSPS; they are both premised on the same categories of criteria or "inputs" (available control options, costs associated with available control options, emission reductions associated with available control options, nonair quality health and environmental impacts associated with available control options, and energy requirements associated with available control options). Further, the EPA's methodology for assessing the "inputs" is the same under the NSPS and the EG.

In the case of many designated facilities for this EG, the value of the "inputs" happens to be the same, or very similar (*i.e.*, there are no meaningful factual differences), such that the outcomes of the analysis happen to be the same or very similar. But that is not always the case. Where meaningful factual differences exist between new and existing sources, the EPA appropriately took those differences into account when developing the presumptive standards in the final EG. Take for example the criteria of costs. For many designated facilities in this EG, the costs of controlling emissions do not include large capital expenditures or retrofit costs because there is no additional equipment to buy and install.⁶⁹⁰ However, this is not the case for every designated facility. For example, the presumptive standards for wells with associated gas in the final EG OOOOc, as discussed in section XI.F.2 of this preamble, are different than the final standard of performance in NSPS OOOOb in part because of cost differences between new and existing sources. By way of another example, in the November 2021 Proposal, the EPA explained relevant cost differences between new and existing tank batteries and concluded that "it is more expensive to install controls at an existing tank battery than to install controls as part of a new tank battery."⁶⁹¹

To the extent that commenters raised particular issues (factual differences) that they thought warranted a different presumptive standard because of some difference between new and existing sources, those comments are addressed separately in the context of the appropriate designated facility. Specifically with regard to costs, the EPA recognizes the general possibility that the costs associated with utilizing various available control options could

⁶⁹⁰ For example, see December 2022 Supplemental Proposal, 87 FR 74792, regarding dry seal compressors ("[t]he application of the numerical emission limit option at an existing source is the same as at a new source because no additional equipment must be installed in order to comply with the standards"). See also 87 FR 74809 ("[t]he application of an LDAR program at an existing source is the same as at a new source because there is no need to retrofit equipment at the site to achieve compliance with the work practice standard").

⁶⁹¹ 86 FR 63110, at 63200. More specifically, EPA "applied a 30 percent retrofit factor to the capital and installation costs to account for added costs of manufacturing existing storage vessels and installing the control system on an existing tank battery." *Id.* After considering the costs for existing sources, EPA found "the cost effectiveness for achieving 95 percent emission reduction of methane from [an existing] tank battery with potential methane emissions of 20 tpy is reasonable for methane." *Id.* at 63201.

vary between new and existing sources. It is also possible that the costs are exactly the same; it depends on various facts that are specific to the individual analysis for each type of designated facility. To the extent that the EPA or commenters identified meaningful cost differences between new and existing sources, those differences are addressed in the context of the discussion about the particular affected and designated facilities.

2. State Flexibilities

a. Leveraging State Programs

As first acknowledged in the November 2021 Proposal, the EPA recognizes that some states already have existing programs they may want to leverage for purposes of satisfying their CAA section 111(d) state plan obligations (86 FR 63252). As stated in the December 2022 Supplemental Proposal,⁶⁹² the EPA believes that for states to successfully leverage their state programs to satisfy their CAA section 111(d) state plan obligations, specific criteria need to be identified for states and the EPA to follow in determining whether a state plan meets the level of stringency required under the final EG, and how such equivalency demonstrations can be made in a rigorous and consistent way such that the integrity of the EG is not undermined. In the December 2022 Supplemental Proposal, the EPA specifically proposed a source-by-source evaluation methodology which consists of five basic criteria to determine whether a source-by-source (or designated facility-by-designated facility) evaluation can be considered for equivalency should any state choose to leverage a state program for purposes of satisfying their CAA section 111(d) state plan obligations. The proposed criteria were: (1) Designated facility, (2) designated pollutant, (3) standard type/format of standard (*e.g.*, numeric, work practice), (4) emission reductions (with consideration of applicability thresholds and exemptions), and (5) compliance assurance requirements (*e.g.*, monitoring, recordkeeping, and reporting). The EPA further proposed a source-by-source equivalency step-by-step approach followed by an example for hypothetical state rules illustrating how states could implement the proposed approach when conducting a state rule equivalency determination with the proposed presumptive standards. The step-by-step approach the EPA proposed in the December 2022 Supplemental Proposal is outlined

below. The EPA is, in large part, finalizing this approach as proposed. Any differences between the December 2022 Supplemental Proposal and the final EG with respect to this approach are explained below.

i. *Step One:* Are the state rule designated facility definition, pollutant, and format the same?

The first question that a state needs to answer is whether its program relied upon for purposes of the CAA 111(d) state plan defines the regulated emissions sources substantially similar to how the EPA defines a designated facility. The state should also address whether the state's program requirements in the state plan for the designated facility regulate the same pollutant (GHGs with standards expressed as limitations on methane), and whether the format of the standard the same (*e.g.*, work practice or performance-based numerical standard). If the answer is "no" to any of these three questions (*e.g.*, state program regulates VOC and not methane), then the state plan cannot include an equivalency determination with the EPA's proposed presumptive standards for the designated facility unless the state program is altered to address the inconsistency. If the answer is yes to all of these questions, a state could proceed to Step Two.

ii. *Step Two:* Emissions reductions.

If a state wishes to rely on their program for purposes of their state plan, and they are not invoking RULOF to justify a less stringent standard, then a state plan needs to include a demonstration that the state requirements for designated facilities achieve the same or greater emissions reduction as the designated facility presumptive standards in the final EG. A state would have several options to make this demonstration.

The first option would be to make a demonstration that the designated facility's state standard achieves the same degree of emission reduction as the designated facility BSER identified in the final EG using the EPA model plant/representative facility. The second option would be to make a demonstration that the designated facility's state standard, when applied to an actual facility in the state, achieves the same or greater emissions reduction as the designated facility model plant/representative facility emission reduction in the BSER analysis. The third option would be to conduct a state-wide emissions comparison, in which the state would apply the designated facility presumptive standard to data reflecting the population of sources in the state (*e.g.*,

using activity data (number of sources) and actual emissions data) and calculate the state-wide emission reduction that would be achieved by apply the presumptive standard, and then demonstrate that the state program requirements for a designated facility would achieve the same or greater emissions reduction. If, for any designated facility type, emissions reductions from the implementation of the state rule are less than would be achieved from the implementation of the final presumptive standards in the EG, and the state does not properly invoke RULOF to justify the less stringent standard(s), then the state cannot make an equivalency determination with the EPA's presumptive standards for that designated facility type. Conversely, if emissions reductions from the implementation of the state rule are the same or greater than would be achieved from the implementation of the presumptive standards, a state could proceed to Step Three.

iii. *Step Three:* Make demonstration that compliance measures included for a designated facility under a state program are adequate.

Once a state has determined that the emissions reductions from the implementation of the state requirements for a designated facility are the same or greater than would be achieved by the implementation of the presumptive standards for a designated facility under Step Two, a state plan would need to include a demonstration that compliance measures (*e.g.*, monitoring, recordkeeping and reporting requirements) are sufficient to ensure continued compliance with the standards and projected emissions reductions. The EPA's presumptive standards included in the final EG are accompanied by compliance measures.

The EPA's intention for providing these criteria is to offer states flexibility while establishing guideposts for states and the EPA to follow to ensure that the state plan would meet the degree of emission limitation required under the EG. These criteria are necessary to ensure that states are establishing standards of performance that meet the statutory requirements of section 111, the EPA's implementing regulations under section 111(d) (subpart Ba), and this final EG. They also enable the EPA to make reasoned decisions that are consistent across states with respect to whether state plans are "satisfactory" and therefore approvable under section 111(d). The EPA solicited comment on all aspects of the proposed state program equivalency demonstration methodology and evaluation criteria. The EPA received significant comments

⁶⁹² 87 FR 74812.

regarding the type of equivalency evaluation. A summary of the comments received and the EPA's response to these comments, including any changes made to the final rule, as applicable are provided below. The EPA's full response to comments on the November 2021 Proposal and December 2022 Supplemental Proposal, including any comments not discussed in this preamble, can be found in the EPA's RTC document for the final rule.⁶⁹³

Types of Equivalency Evaluations: Total Program Evaluation

Within the 2022 Supplemental Proposal, on pages 74813 to 74814, the EPA considered an option to allow "total program evaluation." The EPA opted to not propose such an approach for the concerns expressed in that supplemental proposal. Even though commenters asked the EPA to allow total program evaluations, we are finalizing as proposed to not allow such an approach for the reasons explained below.

Comment: Numerous stakeholders support a total program evaluation rather than the proposed source-by-source methodology. In general, commenters recommend that the EPA maximize flexibility by allowing states to continue implementing their existing state programs.⁶⁹⁴ One commenter implies that for a total program evaluation to work, the EPA would need to allow for emissions averaging across emissions sources to demonstrate equivalency.⁶⁹⁵ Another commenter generally states that they believe a total program evaluation can be employed, with appropriate guardrails, to both ensure significant emissions reductions opportunities will move forward while not disrupting effective state programs that are already in place.⁶⁹⁶ For example, the commenter wrote that states should be required to adopt new requirements for a particular source category only in the following circumstances: (1) where the state program does not include any reduction requirements for a particular source category; or (2) the state does have reduction requirements for a particular

source category but those requirements achieve significantly less emissions reductions than the requirements set forth in the EG relative to the overall emission reductions from the oil and gas sector achieved by the state program. Absent these circumstances, the commenter asserts that the state should retain the flexibility necessary to continue with its current program, provided, of course, that the state can demonstrate that the overall program can achieve comparable emissions reductions to the EG. The comment further advocates that the final rule provide flexibility for states to demonstrate overall program equivalency as it pertains to existing state monitoring, recordkeeping, and reporting requirements. More specifically, the commenter requests that the final rule provide that if a state demonstrates overall program equivalency, changes or additions to existing monitoring, recordkeeping, and reporting provisions only be required where the existing provisions are substantially inadequate to ensure compliance with the associated emissions reductions requirements. The commenter expresses concern that in order to leverage a state program, the state may actually need to modify its existing regulatory provisions, which the commenter believes would undermine the state's implementation processes and practices and lead to less effective state regulation.

Similarly, another commenter requests that the EPA allow states to leverage existing state programs through submittal of total program evaluations to demonstrate equivalency with EG OOOOc.⁶⁹⁷ The commenter contends that precluding states from making a programmatic equivalency determination—by requiring the EPA's source-by-source approach—serves as a disincentive to state rulemaking. More specifically, the commenter argues that the source-by-source evaluation would be an application of a one-size-fits all approach to state regulation in contradiction of the cooperative federalism principles inherent throughout the CAA and specifically enumerated in CAA section 111(d). Further, the commenter believes that the EPA's source-by-source equivalency approach will stifle progressive state rulemaking, as those states would be less likely to expend the significant resources to promulgate new rules only to have the EPA swoop in and set aside well-thought-through state programs.

Another commenter asserts that the EPA's proposal to preclude states from relying on emissions averaging across emissions sources to demonstrate equivalency will prevent states from effectively leveraging existing state programs, require states with existing, comprehensive regulatory programs to undertake additional rulemakings in order to prove identity, rather than equivalency.⁶⁹⁸ They interpret the December 2022 Supplemental Proposal to have proposed a ban on averaging by relying on health-based considerations. The commenter asserts that the EPA justifies its decision to categorically preclude total program evaluations on the grounds that source-by-source equivalency demonstrations will result in greater emissions reductions because states with more stringent regulations for some sources will be required to revise any less stringent regulations to meet the EPA standard. They assert that the EPA's position cannot be squared with the interpretation of CAA section 111(d). The commenter cites to the D.C. Circuit's decision in *American Lung Association* that instructs that for the EPA to bar states from submitting plans that rely on averaging, the EPA must have a source- and pollutant-specific rationale that is justified and supportable.

The same commenter further argues that they believe that CAA section 111(d) does not preclude state plans from including non-designated facilities for the purpose of demonstrating equivalency. The commenter recommends that the EPA allow state plans to include rules that apply to non-designated facilities for the limited purpose of demonstrating the state plan will achieve equivalent emissions reductions as EG OOOOc. The commenter believes that allowing state plans to include regulations that apply to non-designated facilities, for the limited purpose of demonstrating equivalency, is consistent with the "cooperative-federalism approach" adopted by Congress in CAA section 111(d) "that leaves the [s]tates discretion in determining how their [s]tate and industry can best meet quantitative emissions guidelines established by the EPA."

American Lung Ass'n, 985 F.3d at 942. They commenter continues to state that even if the EPA's interpretation is reasonable, the fact that the EPA proposed that a state plan cannot rely on emissions reductions from non-designated facilities does not justify the EPA's wholesale bar on submitting total

⁶⁹³ *Standards of Performance for New, Reconstructed, and Modified Sources and Emissions Guidelines for Existing Sources: Oil and Natural Gas Sector Climate Review. Response to Public Comments on the November 2021 Proposed Rule and the December 2022 Supplemental Proposed Rule* (86 FR 63110, November 15, 2021; 87 FR 74702, December 6, 2022).

⁶⁹⁴ See Document ID Nos. EPA-HQ-OAR-2021-0317-2249, -2286, -2296, -2326, -2390, -2410.

⁶⁹⁵ See Document ID No. EPA-HQ-OAR-2021-0317-2390.

⁶⁹⁶ See Document ID No. EPA-HQ-OAR-2021-0317-2286.

⁶⁹⁷ See Document ID No. EPA-HQ-OAR-2021-0317-2326.

⁶⁹⁸ See Document ID No. EPA-HQ-OAR-2021-0317-2390.

program evaluations. The commenter adds that the EPA does not provide any support in the statute or case law for its interpretation that states cannot rely on regulations that regulate the emission of VOCs or other pollutants, if the state can demonstrate that those regulations achieve equal reductions in methane as a co-benefit. The commenter asserts that the EPA does not rationally justify its concerns about allowing states to rely on different standards, both non-numerical and numerical, in the state plan equivalency demonstrations. The EPA's concern that allowing states to use a non-numerical standard different from the EPA's to demonstrate equivalency "would likely be technically difficult because many of the presumptive standards in the EG OOOOc are work practice standards that do not quantify emissions" fails to support its decision to deprive states of the flexibility Congress granted them under the statute. The commenter believes that the EPA assumes—without support—that this equivalency evaluation would need to be qualitative rather than quantitative because "not all states have comprehensive source and source-specific emissions inventory data [on which] to base a stringency comparison on emissions reductions alone."

The commenter criticizes the EPA's December 2022 Supplemental Proposal by arguing that they believe the EPA did not rationally justify its concerns about allowing states to rely on different standards, both non-numerical and numerical, in the state plan equivalency demonstrations.⁶⁹⁹ They refer back to the joint comment on the November 2021 Proposal from a number of states requesting that the EPA permit the use of different numerical standards.

One commenter recommends that the EPA consider previous regulatory investments and existing state implementation plan approvals.⁷⁰⁰ One commenter asserts that the EPA must provide states an option to demonstrate the equivalency of their existing programs against the EPA's proposed EG because requiring overburdened state agencies to implement and enforce two redundant regulations jeopardizes the regulatory agency's effectiveness and has not been justified in the EPA proposal.⁷⁰¹ The commenter furthermore is concerned that the proposed framework for leveraging state programs does not actually provide

states with regulatory programs an option to demonstrate equivalency because many state's regulated pollutant is VOC rather than GHG (methane) even though VOC will achieve methane co-reductions. The commenter believes the source-by-source criteria and methodology to be unworkable, inflexible, and short-sighted and will result in redundant regulations, unnecessary, and an extremely poor use of state regulatory agencies' limited staffing resources. The commenter believes that it is incumbent upon the EPA to consider the above points and to allow equivalency demonstrations for states and have a streamlined process for the adoption of states' existing rules.

Response: While reviewing and assessing these comments, the EPA observed that commenters do not provide specific alternative criteria or a specific alternative methodology for a total program evaluation that addresses the complexities and challenges unique to the oil and natural gas source category that the EPA identified in the December 2022 Supplemental Proposal.⁷⁰² Furthermore, the EPA observes that some commenters assert claims of equivalency with no supporting documentation to substantiate how they have made that determination articulated in their comments or identifying what criteria they used to compare their program to the December 2022 Supplemental Proposal. For example, the EPA posited that an accurate qualitative comparison on a total-program scale would be extremely complicated given that there are numerous types of designated facilities with presumptive standards, of which some have numerical limits and others are in the format of non-numerical standards. Commenters did not provide the EPA with actionable ideas to address the concern that attempting to assess total program equivalency for this EG would be so complex that the results of such an analysis would likely be difficult to ascertain. The EPA remains concerned with allowing the type of total program equivalency that commenters appear to be asking for because the Agency has been unable to identify a methodology for conducting the comparison that would be likely to produce accurate and reliable results.

Further, while evaluating these comments the EPA observed that total program equivalency would necessarily entail some degree of averaging across different types of designated facilities and recognizes that states would need to establish an emissions reduction

tracking system to account for this averaging. If the EPA understands the commenters correctly, commenters would like the ability to, for example, regulate one type of designated facilities (e.g., fugitive emissions) in a manner that results in more emissions reductions than would occur under the presumptive standard in the EG and "bank" those "extra" reductions to offset for a different type of designated facility (e.g., process controllers) where the state standard would be less stringent than the presumptive standards in the EG. This type of trading or averaging seems necessary to the idea of total program equivalency in the context of this EG. In this particular context, the EPA disfavors this approach and is not allowing this type of averaging in state plans under this EG. It is inherently difficult to accurately measure emissions from some of the designated facilities covered by this EG. More specifically, those designated facilities where the EPA is finalizing non-numerical presumptive standards are difficult to measure. In accordance with 40 CFR 60.24a(b), the EPA is to identify in the EG cases where it is not feasible to prescribe or enforce a standard formed as an allowable rate, quantity, or concentration. The EPA has done so in this EG. If the designated facility cannot be subject to a standard formed as a rate, quantity, or concentration of emissions, then it is logical that accurately measuring the emissions from such a designated facility would be difficult. If a state plan purported to "overregulate" a certain designated facility type that was subject to a non-numerical limit, beyond the presumptive standard in the EG, it would be extremely difficult to determine how much "credit" would be banked for purposes of cross-designated facility averaging. This approach is not workable in a way that would ensure the integrity of the EG.

To be clear, the EPA is not prohibiting all types of averaging in this final EG. On the contrary, states may average within the confines of each type of designated facility (e.g., storage vessel designated facilities to storage vessel designated facilities, pump designated facilities to pump designated facilities, fugitives designated facilities to fugitives designated facilities). This type of averaging does not run afoul of the concerns expressed above regarding total program equivalence. In the context of non-numerical standards, the EPA would expect the averaging associated with the equivalency

⁶⁹⁹ See Document ID No. EPA-HQ-OAR-2021-0317-2390.

⁷⁰⁰ See Document ID No. EPA-HQ-OAR-2021-0317-2249.

⁷⁰¹ See Document ID No. EPA-HQ-OAR-2021-0317-2296.

⁷⁰² See 87 FR 74812-16.

determination to be qualitative.⁷⁰³ This type of averaging to demonstrate equivalence is what the EPA means when discussing “source-by-source” equivalency in the context of leveraging a state plan. States may very well take a different approach to certain types or groups of designated facilities. That is acceptable so long as the state plan follows the criteria laid out earlier in this section on leveraging a state plan. Specifically, step two (Emissions reductions) of the framework the EPA has laid out is the point at which this type of averaging is relevant.

We also clarify that averaging within the confines of each type of designated facility can be a form of a total program equivalence. The EPA recognized this possibility in the December 2022 Supplemental Proposal.⁷⁰⁴ In theory, if a state were to perform a source-by-source evaluation for each type of designated facilities in its state and determine equivalency for each type of designated facility, this would be a form of total program equivalency. Note however that this is distinct from the type of total program evaluation commenters advocate for and which the EPA is disallowing.

The EPA also remains concerned about other complicating scenarios previously identified in the December 2022 Supplemental Proposal. Specifically, the EPA identified one scenario in which there are instances where a state covers part or a subset of the EG designated facility’s applicability definitions. For example, Colorado requires the use of non-emitting⁷⁰⁵

process controllers with specific exceptions. One exception is that operators do not have to retrofit their controllers to become non-emitting if on a company-wide basis, the average production from producing wells in 2019 is less than 15 barrel of oil equivalent/day/well. However, as discussed in section XI.D of this preamble, the presumptive standard for process controllers included in the final EG is a methane emissions rate of zero with no site-wide production or other applicability threshold. Thus, the definition of the designated facility for controllers in the final EG covers a broader group of controllers than does Colorado’s regulations. This would be problematic in a state plan because under CAA 111(d) and 40 CFR part 60, subpart Ba, the state plan must include standards of performance for all designated facilities. Commenters did not provide the EPA with suggestions or ideas to address this concern. If the EPA were to permit total program equivalence in situations like this where the scope of the sources subject to regulation in the state programs do not align with the scope of coverage by the EG, then there could be situations where a state would be allowed to forgo regulating some designated facilities which the text of CAA section 111(d) says should be subject to standards of performance in a state plan. After review of the comments received, the EPA remains concerned that a total program evaluation would not guarantee that the same level of emissions reductions as identified in the EG would be achieved.

In a related scenario, the EPA recognizes states may have broader thresholds for regulatory coverage that may differ from the EPA’s EG definitions of designated facilities. For example, a state may cover a broader set of sources compared to the EG’s designated facility applicability threshold. The EPA acknowledges that states may choose to regulate non-designated facilities under state law for other purposes than to satisfy their CAA section 111(d) state plan submission requirement. However, the EPA does not find it appropriate to allow a state to account for non-designated facilities for purposes of demonstrating program equivalency to the degree of emission limitation required by the EG, even if a state regulates such sources as a matter of state law. Put another way, for purposes of this EG, a state cannot bank credit for portions of a state plan that

routing emissions to a combustion device is not an option for compliance with the presumptive standard.

rely on state laws that regulate sources that are not designated facilities. CAA section 111(d) requires states to establish standards of performance for designated facilities that achieve the degree of emission limitations identified by the Administrator. Accordingly, the emission reductions relied upon for purposes of leveraging a state program to demonstrate source-by-source equivalency should come from designated facilities. To be clear, the final EG in no way impacts states’ ability to regulate sources under state law. States are still free to choose how to regulate sources. This section of this preamble is speaking to what are creditable emission reductions for purposes of averaging in a state plan submitted to the EPA under CAA 111(d) and 40 CFR part 60, subpart Ba, for purposes of this final EG.

In addition, the EPA reiterates its interpretation that CAA section 111(d) does not allow the EPA to approve state plan requirements for different pollutants other than those designated pollutants in the EG. Subpart Ba defined “designated pollutant” at 40 CFR 60.21a(a). The EPA is aware that while numerous states have programs in place that regulate emissions from the designated facilities that the EPA is finalizing presumptive standards for, many of those programs do not regulate GHGs in the form of limitations on methane. Some state programs regulate VOC. State plans must regulate the designated pollutant, which for this EG is GHGs in the form of limitations on methane. Further, as the EPA explained in the 2021 Proposal, states must submit plans “to establish standards of performance for existing sources for any air pollutant: (1) The emission of which is subject to a Federal NSPS; and (2) which is neither a pollutant regulated under CAA section 108(a) (*i.e.*, criteria pollutants such as ground-level ozone and particulate matter, and their precursors, like VOC) [footnote omitted] or a HAP regulated under CAA section 112.” 86 FR 63110 at 63134. While VOC are not specifically listed as CAA section 108(a) pollutants, the EPA is regulating VOC in the NSPS that corresponds to this EG as precursors to photochemical oxidants (*e.g.*, ozone) and particulate matter (PM), both of which are listed CAA section 108(a) pollutants. Therefore, VOC fall within the CAA 108(a) exclusion here, and the EPA cannot approve a state plan that establishes standards of performance for VOC.

The EPA clarifies we are not finalizing a framework that demands the state plan be identical to the EG. Under this EG, and consistent with the

⁷⁰³ For an example of a qualitative equivalency determination in the context of the oil and natural gas source category, see memorandum, “Equivalency of State Fugitive Emissions Programs for Well Sites and Compressor Stations to Final Standards at 40 CFR part 60, subpart OOOOa,” located at Docket ID No. EPA-HQ-OAR-2017-0483 (January 17, 2020).

⁷⁰⁴ See 87 FR 74814.

⁷⁰⁵ The phrases “zero emissions” and “non-emitting” are used to describe process controllers, but the EPA does not use these phrases to mean the same thing. In Colorado, 5 CCR Regulation 7, Part D, Section III, defines a “non-emitting” controller as “a device that monitors a process parameter such as liquid level, pressure or temperature and sends a signal to a control valve in order to control the process parameter and does not emit natural gas to the atmosphere. Examples of non-emitting controllers include but are not limited to: no-bleed pneumatic controllers, electric controllers, mechanical controllers and routed pneumatic controllers.” A routed pneumatic controller is defined as “a pneumatic controller that releases natural gas to a process, sales line or to a combustion device instead of directly to the atmosphere.” The EPA’s final EG includes a presumptive standard for process controllers of zero emissions. The difference between non-emitting, as defined by Colorado, and zero emissions, as used in this action, is that process controllers for which emissions are captured and routed to a combustion device do not have zero emissions. Therefore,

cooperative federalism framework of CAA section 111(d), states have the prerogative to develop state plans and have flexibility to adopt standards that diverge from the presumptive standards finalized here (including by considering RULOF in the development of their state plans). However, the EPA specifies that the designated facilities and the regulated pollutants must be the same as specified in the EG. Further, unless the state is invoking RULOF to justify a less stringent standard, the state must demonstrate its plan achieves the degree of emission limitation in the EG in order to be approvable. After consideration of comments and for the reasons detailed in this section and the critical need to provide clear regulatory certainty to the hundreds of thousands of designated facilities in this uniquely large source category, the EPA does not find that a total program evaluation along the lines that commenters describe would guarantee that the same emissions reductions as required by the EG would be achieved. Therefore, the EPA is not finalizing a framework to allow total program equivalency as commenters describe.⁷⁰⁶

Types of Equivalency Evaluations:
Source-by-Source Evaluation

Comment: One commenter recommends that the EPA provide more clarity and specificity in its articulation

of Steps 2 and 3 of the source-by-source equivalency determination, particularly offering clarity about the approval of alternative technologies.⁷⁰⁷ The commenter recommends that the EPA establish guidance and work with states who choose to leverage their programs for purposes of their state plan submittal; the commenter believes this collaboration would pose little burden on the EPA. In addition, they suggest that ongoing resources be devoted to offering cooperative and consultative technical support to these states. The commenter recommends that the EPA be consistent across different regions in these determinations. However, the commenter asserts that the EPA must be clear in any guidance and offer a streamlined process for equivalency to give state and local agencies a high degree of certainty in leveraging their programs.

Response: The EPA remains committed to working with states as they develop and submit state plans to the Agency for review. The EPA strives to maintain consistency in its collaboration with states to ensure that implementation of the EG will be uniform. Please see discussion in section XIII.D. and XIII.F. of this preamble related to components of state plan submissions and the EPA action on state plans.

The EPA provides the following example for hypothetical state rules illustrating how states could implement the source-by-source (designated facility-by-designated facility) evaluation when conducting a state rule equivalency determination with the presumptive standards.

Centrifugal Compressor Examples—
Comparison of Presumptive Standards
With 4 Hypothetical Examples

Table 27 provides examples of the application of the steps outlined above for five hypothetical state rules for reciprocating compressors at gathering and boosting stations in the production segment. The parameters for the presumptive standard for reciprocating compressors are as follows.

- (1) The designated facility is a single reciprocating compressor.
- (2) The designated pollutant is methane, using volumetric flow rate as a surrogate for methane.
- (3) The standard type/format of standard is a numerical standard (2 scfm volumetric flow rate).
- (4) The estimated methane emissions reductions for the model compressor in the BSER analysis for the presumptive standard was 92 percent reduction.
- (5) The compliance assurance requirements include the requirement to measure the flow rate once every 8,760 operating hours and maintain records.

TABLE 27—RECIPROCATING COMPRESSOR DESIGNATED FACILITY PRESUMPTIVE STANDARDS EQUIVALENCY EVALUATION EXAMPLES

Designated facility requirements	Equivalency determination steps		
	Step One— Applicability and format of standard	Step Two— Emission reduction	Step Three— Compliance assurance measures
Example A			
<p><i>Designated Facility:</i> Single Reciprocating Compressor at Gathering and Boosting. <i>Designated Pollutant:</i> Methane. <i>Format of Standard:</i> Work Practice (Change out rod packing every 3 years). <i>Estimated Emissions Reduction (Basis):</i> 56 percent (model compressor basis). <i>Compliance Assurance Requirements:</i> Records of changeout.</p>	<p>FAIL—format of standard not equivalent.</p>		

⁷⁰⁶ While the RIA includes information on state-level estimates of emissions reductions that could result from the final EG, it's not sufficient to judge the equivalence of a state plan. The RIA is intended

to be illustrative in nature and is not precise enough to rely upon in an analysis of total program equivalency.

⁷⁰⁷ See Document ID No. EPA-HQ-OAR-2021-0317-2249.

TABLE 27—RECIPROCATING COMPRESSOR DESIGNATED FACILITY PRESUMPTIVE STANDARDS EQUIVALENCY EVALUATION EXAMPLES—Continued

Designated facility requirements	Equivalency determination steps		
	Step One— Applicability and format of standard	Step Two— Emission reduction	Step Three— Compliance assurance measures
Example B			
<p><i>Designated Facility:</i> Single Reciprocating Compressor at Gathering and Boosting. <i>Designated Pollutant:</i> Total hydrocarbon as Surrogate for Methane. <i>Format of Standard:</i> Numerical (Collect and route to control to achieve 95 percent reduction). <i>Estimated Emissions Reduction (Basis):</i> 95 percent (model compressor basis). <i>Compliance Assurance Requirements:</i> Performance test of control device, continuous parameter monitoring, recordkeeping and reporting.</p>	PASS	PASS	PASS.
Example C			
<p><i>Designated Facility:</i> Single Reciprocating Compressor at Gathering and Boosting. <i>Designated Pollutant:</i> Total Gas Flow rate as surrogate for methane. <i>Format of Standard:</i> Directed Inspection and Maintenance (Measure flow rate annually and replace or repair if volumetric flow is greater than 3 scfm). <i>Estimated Emissions Reduction (Basis):</i> 92 percent (model compressor basis). <i>Compliance Assurance Requirements:</i> Records of measurements, records of corrective actions if greater than 3 scfm, records of new measurement to demonstrate less than 3 scfm after corrective action.</p>	FAIL—format of standard not equivalent.		
Example D			
<p><i>Designated Facility:</i> Single Reciprocating Compressor at Gathering and Boosting. <i>Designated Pollutant:</i> Total gas flow rate as surrogate for methane. <i>Format of Standard:</i> Numerical: 5 scfm. <i>Estimated Emissions Reduction (Basis):</i> using analysis of state-wide emissions from actual reciprocating compressors, estimated that EG presumptive standard would achieve 85 percent reduction over the state, state rule would achieve 87 percent reduction. <i>Compliance Assurance Requirements:</i> Measure volumetric flow rate once every 6 months, record results.</p>	PASS	PASS—Demonstrated that the “real life” state-wide emission reduction for state rule was greater than the “real-life” reduction for the presumptive standard.	PASS.
Example E			
<p><i>Designated Facility:</i> Single Reciprocating Compressor at Gathering and Boosting. <i>Designated Pollutant:</i> Total gas flow rate as surrogate for methane. <i>Format of Standard:</i> Numerical: 4 scfm. <i>Estimated Emissions Reduction (Basis):</i> 88 percent (analysis of state-wide emissions from actual reciprocating compressors). <i>Compliance Assurance Requirements:</i> Measure volumetric flow rate once every 6 months, record results.</p>	PASS	FAIL—did not demonstrate that the BSER presumptive standard model facility reduction was met.	

The EPA further clarifies how we intend these steps of the source-by-source equivalency determination to work with regards to the use of alternative technologies for monitoring of fugitive emissions. For illustrative purposes to assist with this response, we have identified three possible scenarios. First, if a state incorporates the presumptive standards and the associated advanced methane detection technology provisions from the EG model rule into their approved state

plan submittal, then it would be reasonable to expect that when the EPA approves an alternative technology in the future, the designated facilities in the state could use the alternative technology. In a second scenario, if a state incorporates the presumptive standards but wants its state plan to include different alternative technology criteria, the state must demonstrate equivalence between the state’s criteria and the criteria in the final EG. The EPA acknowledges however that certain

authorities are retained by the EPA and a state would not have the authority to approve the alternative technology itself. Specifically, in § 60.5373c the EPA lists authorities that will not be delegated to state, local, or Tribal agencies including but not limited to the approval of major alternatives to test methods and the approval of major alternatives to monitoring. In a third scenario, if the state’s plan includes a standard that is not the presumptive standard from the EG and also different

alternative technology criteria than those included in the EG, the state would need to ensure that: (1) Their standard is equivalent to the presumptive standard (or invoke RULOF), and (2) the alternative technology criteria are equivalent to those included in the EG. However, just as with the second scenario, the authority to approve the alternative technology would be retained by the EPA.

b. Averaging

As discussed in XIII.C.2.a of the December 2022 Supplemental Proposal, the EPA stated that CAA section 111(d) authorizes the EPA to allow states, in particular rules, to achieve the requisite emissions limitation through the aggregate reductions from their sources, and the EPA accordingly proposed to authorize states to leverage their state programs in specific ways to satisfy their CAA section 111(d) state plan obligations pursuant to the EG OOOOc. More specifically, the EPA proposed that states may average within the confines of each type of designated facility (e.g., pump designated facilities to pump designated facilities). As discussed previously, the EPA is allowing this type of averaging under the final EG. The EPA clarifies that this type of averaging may be used regardless of whether a state chooses to leverage an existing state program that predated EG OOOOc for purposes of their state plan submission. In other words, states may average within the confines of each type of designated facility even if a state does not choose to leverage an existing program, or if the state has no existing program and is developing new regulations in response to the EG for their state plan. In those situations, the EPA believes states can still use the discussion in section XIII.C.2.a of this document as guidance for ensuring their state plan is equivalent to the EG. Also, as discussed previously, the EPA is not allowing the type of averaging that commenters appear to be asking for when they discuss total program equivalency. The EPA's concerns with total program equivalency specific to this EG are explained above. The EPA received significant comments regarding the use of averaging in the state plan submittal. The EPA believes that the discussion on averaging above in this section responds to the most significant of those comments. The EPA's full response to comments on the November 2021 Proposal and December 2022 Supplemental Proposal, including any comments not discussed in this

preamble, can be found in the EPA's RTC document for the final rule.⁷⁰⁸

c. General Permitting Programs

The EPA continues to recognize that some states may choose to regulate designated facilities under the EG through a general permit program. For example, general permits often include standardized terms and conditions related to emissions control, compliance certification, notification, recordkeeping, reporting, and source testing requirements. The EPA is not finalizing a regulatory provision on this topic within EG OOOOc, but confirms that the implementing regulations under subpart Ba allows for standards of performance and other state plan requirements to be established as part of state permits and administrative orders, which are then incorporated into the state plan. See 40 CFR 60.27a(g)(2)(ii).

However, the EPA notes that the permit or administrative order alone may not be sufficient to meet the requirements of an EG or the implementing regulations, including the completeness criteria under 40 CFR 60.27a(g). For instance, a plan submission must include supporting material demonstrating the state's legal authority to implement and enforce each component of its plan, including the standards of performance. *Id.* at 40 CFR 60.27a(g)(2)(iii). In addition, EG OOOOc requires demonstrations that may not be satisfied by terms of a permit or administrative order. To the extent that these and other requirements are not met by the terms of the incorporated permits and administrative orders, states will need to include materials in a state plan submission demonstrating how the plan otherwise meets those requirements.

3. Remaining Useful Life and Other Factors (RULOF)

In the December 2022 Supplemental Proposal, the EPA proposed and solicited comment on requirements related to states' use of RULOF when applying standards of performance in their state plan submittals.⁷⁰⁹ However, the EPA is not finalizing any substantive provisions related to RULOF in EG OOOOc. The only provision included in the final version of EG OOOOc that relates to RULOF is 40 CFR 60.5365c,

⁷⁰⁸ *Standards of Performance for New, Reconstructed, and Modified Sources and Emissions Guidelines for Existing Sources: Oil and Natural Gas Sector Climate Review. Response to Public Comments on the November 2021 Proposed Rule and the December 2022 Supplemental Proposed Rule* (86 FR 63110, November 15, 2021; 87 FR 74702, December 6, 2022).

⁷⁰⁹ See 87 FR 74816 (December 6, 2022).

which directs states to the RULOF requirements specified in 40 CFR 60.24a (subpart Ba).

Since the supplemental proposal, the EPA has promulgated revisions to subpart Ba.⁷¹⁰ These revisions represent the final, generally applicable requirements for RULOF, including consideration of the topics that the EPA addressed in the December 2022 Supplemental Proposal, and are applicable to these EG. State plans submitted in accordance with these EG that include provisions for RULOF must comply with the subpart Ba general RULOF provisions in 40 CFR 60.24a.⁷¹¹ As such, the EPA did not find it necessary to also finalize similar provisions in these EG as they would have been redundant with those recently finalized via a separate rulemaking process in subpart Ba.

For informational purposes, the EPA will summarize the RULOF provisions that have been finalized in the subpart Ba rulemaking, which is separate and distinct from this action. 40 CFR 60.24a(e) explains that states may apply a standard of performance to a particular designated facility that is less stringent than otherwise required by an applicable EG taking into consideration that facility's RULOF, provided that the state demonstrates with respect to each such facility (or class of such facilities) that the facility cannot reasonably achieve the degree of emission limitation determined by the EPA based on: (1) unreasonable cost of control resulting from plant age, location, or basic process design; (2) physical impossibility or technical infeasibility of installing necessary control equipment; or (3) other factors specific to the facility. The state must demonstrate that there are fundamental differences between the information specific to a facility or class of such facilities and the information the EPA considered in determining the degree of emissions limitation achievable through application of the BSER that make achieving such degree of emissions limitation unreasonable for that facility. Similarly, the state may apply a compliance schedule to a particular designated facility, or class of such facilities, that is longer than provided in an applicable emissions guideline taking into consideration that facility's RULOF, provided the state demonstrate there are fundamental differences between the information specific to the

⁷¹⁰ 88 FR 80480 (November 17, 2023).

⁷¹¹ See 40 CFR 60.20a(a), which establishes applicability of subpart Ba requirements to EG OOOOc. Further, EG OOOOc does not supersede any requirement within subpart Ba related to RULOF.

facility and the information the EPA considered in determining the compliance schedule.

If a state makes the demonstration in 40 CFR 60.24a(e), the plan may apply a standard of performance that is less stringent than required by an applicable EG. Such standard of performance must meet the requirements in 40 CFR 60.24a(f): (1) The standard must be no less stringent (or have a compliance schedule no longer) than is necessary to address the fundamental differences identified under 40 CFR 60.24a(e). To the extent necessary to determine a standard of performance, the state must evaluate the systems of emission reduction identified in the applicable EG using the factors and evaluation metrics the EPA considered in assessing those systems, including technical feasibility, the amount of emission reductions, the cost of achieving such reductions, any nonair quality health and environmental impacts, and energy requirements. The states may also consider, as justified, other factors specific to the facility that were the basis of the demonstration under 40 CFR 60.24a(e) as well as other systems of emission reduction in addition to those the EPA considered in the applicable EG. (2) The standard of performance under 40 CFR 60.24a(f) must be in the form as required by the applicable EG. 40 CFR 60.24a(g) requires that where a state applies a less stringent standard of performance on the basis of an operating condition(s) within the designated facility's control, such as remaining useful life or restricted capacity, the plan must include such operating condition(s) as an enforceable requirement and provide for the implementation and enforcement of the operating condition(s), such as requirements for monitoring, reporting, and recordkeeping. 40 CFR 60.24a(h) requires that a less stringent standard of performance meet all other applicable requirements in subpart Ba and the applicable EG.

Even though the EPA is not finalizing any RULOF requirements in EG OOOOc that are unique to the oil and natural gas industry, the EPA has provided information and analysis on this subject that states should consider when developing their state plans for this EG. First, as a point of clarification, application of the RULOF provisions in the context of EG OOOOc is distinct from source-by-source equivalency evaluations (that can account for a type of averaging) discussed earlier in section XIII.C.2 of this document. RULOF applies where a state intends to *depart* from the presumptive standards in EG OOOOc to apply a less stringent

standard for a designated facility or class of facilities. That is, the RULOF provisions are relevant to a state's process of applying a standard of performance to an existing source in the first instance. In contrast, averaging is a mechanism that states may use to demonstrate compliance with the standards of performance that they have previously determined and are contained within their state plans. States are not required to use the RULOF provisions in order to implement averaging mechanisms to comply with a standard of performance that reflects the presumptive standard in EG OOOOc.

Next, the EPA continues to find that states ought to consider certain circumstances that are specific to remaining useful life and the concept of unreasonable costs for EG OOOOc. The EPA explained these considerations within the December 2022 Supplemental Proposal. 87 FR 74822–23. Remaining useful life is the one “factor” that CAA section 111(d) explicitly requires that the EPA permit states to consider in applying a standard of performance. Subpart Ba allows for a state to account for remaining useful life to apply a standard that is less stringent than the corresponding EG. Moreover, the recent revisions to subpart Ba, as explained above, clarified the circumstances in which states may invoke RULOF based on an existing source's remaining useful life, as well as the process for doing so.

For purposes of this discussion, which is specific to EG OOOOc, the relevant provision of subpart Ba is 40 CFR 60.24a(e), which allows states to apply a less stringent standard if the state demonstrates that a facility, or class of facilities, cannot reasonably achieve the degree of emission limitation determined by the EPA based on, *inter alia*, unreasonable cost of control resulting from plant age. As explained in the December 2022 Supplemental Proposal, the EPA believes that the ability to demonstrate cost unreasonableness based on a source's remaining useful life would likely depend on whether the facility will be required to make a capital investment to comply with the presumptive degree of emission limitation.

When the EPA determined the degree of emission limitation achievable through application of the BSER in this EG, as required by CAA section 111(a)(1), it considered costs of controls and, in many instances, the EPA specifically considered annualized costs associated with payment of the total capital investment of the technology associated with the BSER. In the

estimation of this annualized cost, the EPA assumes an interest rate and a capital recovery period, sometimes referred to as the payback period. The EPA provided the following example in the December 2022 Supplemental Proposal of how cost effectiveness is evaluated in these circumstances. This illustrative example is still helpful to understand the EPA's position and is therefore repeated here. In the estimation of the annual costs for the installation of an instrument air system to power process controllers with compressed air at a medium-sized transmission and storage site, the EPA estimated that the total capital investment (equipment and installation) of the system would be \$76,481. For the BSER analysis, the EPA assumed an interest rate of 7 percent and a capital recovery period of 15 years. This means that the annual cost of recovering the initial capital investment including interest, was \$8,397 per year for 15 years. The total annual cost includes this capital recovery cost plus the additional operation and maintenance cost of the equipment (additional beyond what would be required for a natural gas-driven controller system). For this example, the additional operation and maintenance cost was estimated to be \$2,816 per year, resulting in a total annual cost of \$11,213 and a cost effectiveness of \$1,250 per ton of methane removed, which is a value within the range considered reasonable by the EPA.

Therefore, for this illustrative example, the cost effectiveness is reasonable considering a capital recovery period, or payback period, of 15 years. If the remaining useful life of a particular facility were to be less than 15 years, the result could be a cost effectiveness value for that facility that is outside of the range considered reasonable by the EPA, *i.e.*, is fundamentally different from the cost of control the EPA considered in EG OOOOc. For example, consider a remaining useful life of 6 years. The resulting capital recovery cost would be \$26,742 per year and total annual cost would be \$29,196. This would yield a cost effectiveness of \$1,834 per ton of methane removed, which would still be in the range considered reasonable by the EPA. Therefore, the state would not be able to claim under 40 CFR 60.24a(e) that the costs were unreasonable for a remaining useful life of 6 years. However, if the remaining useful life were only 2 years, the capital recovery cost would be \$70,502 per year and the total annual cost would be \$72,956. The cost effectiveness of this would be

almost \$4,600 per ton of methane removed, which is outside of the range considered reasonable by the EPA in this action. In this situation, this could potentially be used as part of a RULOF demonstration under subpart Ba to justify applying a less stringent standard.

Note that this specific example is only for illustrative purposes. For process controller designated facilities, EG OOOOc identifies the degree of emission limitation achievable as zero methane emissions (100 percent reduction). To invoke RULOF to apply a less stringent standard of performance, the state must show “that the facility cannot reasonably achieve the degree of emission limitation determined by the EPA.” 40 CFR 60.24a(e). While the example examines one potential control option to achieve the identified degree of emission limitation, there are other equivalent control options (e.g., electric controllers) that are considerably less expensive than the installation of an instrument air system. The EPA still finds this example helpful though because all zero-emissions control options for process controllers entail capital investment.

In the December 2022 Supplemental Proposal, the EPA distinguished the application of remaining useful life based on cost unreasonableness for sources that would not incur capital costs to comply with the presumptive degree of emission limitation and proposed to preclude states from relying on the remaining useful life factor for certain specified facilities. While the EPA continues to believe that a cost unreasonableness determination based on remaining useful life for certain designated facility types (such as fugitive emissions, which do not entail large capital expenditures) would very likely not be justified under the RULOF provisions of subpart Ba, the EPA is not finalizing a regulatory provision prohibiting states from attempting to make such a demonstration in developing state plans for EG OOOOc.

Nonetheless, the EPA continues to believe that for purposes of this EG the only cost factor that would likely be reasonable to consider in a remaining useful life determination of cost unreasonableness is whether there is a significant capital investment required to design, purchase, and install equipment. This is based on how the EPA conducted the relevant BSER analyses that resulted in the presumptive standards included in this final EG. The BSER determinations in EG OOOOc that are based on compliance measures that do not require such upfront capital

expenditures were not based on the assumption that the compliance costs would need to be amortized over a payback period in order to be considered cost reasonable, and therefore are reasonable for designated facilities that operate for any period of time into the future. If the presumptive standard included in this final EG does not require upfront capital expenditures, then the EPA believes it would be extremely unlikely that a state could demonstrate, based on costs relative to remaining useful life, “that there are fundamental differences between the information specific to a facility (or class of such facilities) and the information EPA considered in determining the degree of emission limitation achievable through application of the best system of emission reduction or the compliance schedule that make achieving such degree of emission limitation or meeting such compliance schedule unreasonable for that facility.” 40 CFR 60.24a(e)(2). Accordingly, a cost unreasonableness showing based on remaining useful life under 40 CFR 60.24a(e) would likely only be appropriate for the following types of designated facilities in this EG: oil wells with associated gas, storage vessels, process controllers, and pumps. While states are not precluded from attempting to demonstrate cost-unreasonable based on remaining useful life for other designated facility types in this EG, the EPA does not believe that such a demonstration for the other designated facilities would likely satisfy the requirements of subpart Ba.

Note that this discussion is specific to application of 40 CFR 60.24a(e) based on unreasonable cost of control resulting from plant age (remaining useful life) within the context of this specific EG (OOOOC) and does not speak to application of the other circumstances provided in 40 CFR 60.24a(e).

Within the December 2022 Supplemental Proposal, the EPA solicited comment on “whether EG OOOOc should include a single ‘outermost retirement date’ that would define the maximum length of time that would qualify for a designated facility to operate at a less stringent standard based on remaining useful life.” 87 FR 74823. The EPA’s reasoning for soliciting comments on this issue was that establishing such an outermost retirement date could avoid potential inequities associated with different states making demonstrations that result in different remaining useful life periods for the same types of designated facilities. After reviewing comments and considering this issue in conjunction

with the final provisions promulgated as part of 40 CFR part 60, subpart Ba, the EPA has determined that establishing outermost retirement dates in this EG is not necessary to avoid the potential inequities that the Agency expressed concern about in the December 2022 Supplemental Proposal. Specifically, the EPA finds that this potential inequity will be mitigated by the requirements within subpart Ba mandating that any standard less stringent than otherwise required by the EG be no less stringent than necessary to address the fundamental differences between the facility and the information the EPA considered when developing the EG. 40 CFR 60.24a(f)(1). This will help to ensure that the state’s basis for relying on a particular retirement date to establish a less stringent standard is well-justified. Moreover, the EPA recognizes the possibility, in the context of this EG, that certain designated facilities may be situated such that different remaining useful life periods for the same types of designated facilities could be justified. Due to the large number of existing sources, the wide variety of configurations, and the fact that the EPA’s presumptive standards already include subcategories for some types of designated facilities, it is conceivable that fact-specific circumstances taken into account when applying the RULOF process in subpart Ba could result in different remaining useful life periods for the same types of designated facilities.

Lastly, as previously discussed, subpart Ba requires that when an operational condition is used as the basis for applying a less stringent standard, the state plan must include that condition as a federally enforceable requirement. 40 CFR 60.24a(g). Accordingly, if a state applies a less stringent standard by accounting for remaining useful life, per subpart Ba, the state must include in the state plan the retirement date for the designated facility as an enforceable commitment and include measures that provide for the implementation and enforcement of such commitment. For example, the state could adopt a regulation or enter into an agreed order specifying that the designated facility will not operate beyond a certain date (the facility’s planned retirement date), and that regulation or agreed order would then be incorporated into the state plan. The state could also choose to incorporate the retirement date into a permit, such as a preconstruction permit, and incorporate that permit into the state plan.

As required by CAA section 111(d) and subpart Ba, a state plan must

include a standard of performance that applies to a designated facility until its retirement (all designated facilities must be subject to a standard of performance). If the state is invoking RULOF to apply a less stringent standard, then the less stringent standard “must be no less stringent . . . than is necessary to address the fundamental differences” between the relevant facility and the information the EPA considered when developing the EG. 40 CFR 60.24a(f)(1). The EPA recognizes that, in some instances, a designated facility may intend to retire imminently such that the remaining useful life of that facility results in costs that are fundamentally different from the costs that the EPA considered in EG OOOOc. In such situations it may not be reasonable to require that any additional controls be installed, based on the source’s exceptionally short remaining useful life. This could be especially true if such controls require upfront capital expenditures. In the case of an imminently retiring source, the EPA continues to believe that states should apply a standard of performance no less stringent than one that reflects the designated facility’s current operations.

The EPA explained this position in the December 2022 Supplemental Proposal at page 74823. If the fundamental difference between the facility at issue and the information that the EPA considered in this EG is that the facility intends to cease operations in the very near future, then it seems apparent to the EPA that the requirements of subpart Ba as applied to this EG would result in a standard that is no less stringent than what the source is already doing to control emissions. The EPA believes it would be extremely unlikely that a state could justify a standard less stringent than maintaining the existing level of emission control already in place at the facility.

4. Providing Measures That Implement and Enforce Such Standards

In conjunction with establishing standards of performance, state plans must also include compliance schedules for those standards, and, where required by the applicable EG, must also include increments of progress. See 40 CFR 60.24a(a) and (d). Section XIII.E explains the timing of state plan submissions, compliance schedules, and increments of progress for EG OOOOc. The EPA’s subpart Ba implementing regulations require that state plans shall require final compliance as expeditiously as practicable, but no later than the compliance times specified in the applicable EG. See 40 CFR 60.24a(c). States that identify a need for longer

compliance times than those specified in the final EG must invoke RULOF to justify those longer times. See 40 CFR 60.24a(e)–(h). Moreover, 40 CFR 60.24a(d) requires state plans to include increments of progress when the compliance schedule under the applicable EG extends more than 20 months after the state plan submittal date. Since the compliance schedule for EG OOOOc is 36 months, the EPA has considered the need for and ultimately required increments of progress to be included in state plans. States that invoke RULOF to justify a compliance schedule longer than 36 months should consider whether additional increments of progress, beyond those required in EG OOOOc, are “necessary to permit close and effective supervision of progress toward final compliance.” 40 CFR 60.24a(d). Where a state invokes RULOF to apply a less stringent standard of performance, the compliance schedule must be as expeditious as practicable but no later than the time specified in EG OOOOc, 40 CFR 60.24a(c), unless the state also justifies a longer compliance schedule pursuant to 40 CFR 60.24a(e) and (f).

In addition to establishing standards of performance and compliance schedules, state plans must also include, adequately document, and demonstrate the methods employed to implement and enforce the standards of performance such that the EPA can review and identify measures that assure transparent and verifiable implementation. As part of ensuring that regulatory obligations appropriately meet statutory requirements such as enforceability, the EPA has historically and consistently required that obligations placed on sources be quantifiable, non-duplicative, permanent, verifiable, and enforceable. See 40 CFR 60.27a(g)(3)(vi). In accordance with the EPA’s implementing regulations, standards of performance required for designated facilities as part of a state plan to implement the EG must be non-duplicative, permanent, verifiable, and enforceable. Further, in this EG and in accordance with subpart Ba at 60.24a(b), the EPA has identified certain types of designated facilities where the Agency has determined that it is not feasible to prescribe or enforce a standard based on an allowable rate, quantity, or concentration of emissions (numeric limit). For these, the final EG includes non-numerical presumptive standards, consistent with CAA section 111(h)(1), sometimes referred to in shorthand as presumptive “work practice standards” but which can also be design,

equipment, or operational standards, or a combination thereof.⁷¹² When states include non-numerical limits in their plan, “the plan shall, to the degree possible, set forth the emission reductions achievable by implementation of such standards, and may permit compliance by the use of equipment determined by the State to be equivalent to that prescribed.” 40 CFR 60.24a(b). A state plan implementing the EG should include information adequate to support a determination by the EPA that the plan meets these requirements.

Additionally, states must include appropriate monitoring, reporting, and recordkeeping requirements to ensure that state plans adequately provide for the implementation and enforcement of standards of performance. See 40 CFR 60.25a. The model rule included within the final EG OOOOc includes many monitoring, reporting, and recordkeeping provisions associated with the final presumptive standards. Within the 2022 Supplemental Proposal, the EPA clarified our position “that states maintain the same monitoring, reporting, and recordkeeping requirements, or equivalent requirements as described in EG OOOOc for presumptive standards that states adopt in their plans.” 87 FR 74702 at 74826. The EPA is finalizing this approach because the Agency has determined that the monitoring, reporting, and recordkeeping provisions included in the final EG are necessary to implement and enforce the associated presumptive standards. Put another way, if a state chooses to include a final presumptive standard in their state plan, then they need to also incorporate the associated final monitoring, recordkeeping, and reporting requirements contained in the model rule, or equivalent requirements, to ensure that the state plan adequately provides for the implementation and enforcement of the standard of performance. Where a state plan includes standards of performance that differ from the presumptive standards, the plan may accordingly include different monitoring, reporting, and recordkeeping requirements than those in the final model rule, but such requirements must be appropriate for the implementation and enforcement of the standards. In those situations, states may still find the monitoring, reporting, and recordkeeping provisions included in the model rule helpful and informative for development of their

⁷¹² See tables 25 and 26 in this preamble for summary of final EG subpart OOOOc presumptive standards.

state plan. The EPA reviews all state plan submittals for approvability through notice and comment rulemaking. As such, components of a state plan that differ from any presumptively approvable aspects of the EG, including monitoring, reporting, and recordkeeping provisions included in a state plan, will be thoroughly reviewed by the EPA and will be subject to review and comment by the public.

5. Emissions Inventories

Within the November 2021 Proposal, the EPA solicited comment on whether to supersede the emission inventory requirements of 40 CFR 60.25a(a).⁷¹³ Based on comments received, in the December 2022 Supplemental Proposal, the EPA proposed to supersede the requirements of 40 CFR 60.25a(a) for purposes of this EG, so that state plans are not required to include an inventory and emissions data as described under that subpart Ba provision. The implementing regulations at 40 CFR 60.25a contain generally applicable requirements for emission inventories, source surveillance, and reports. 86 FR 63253 (November 16, 2021). 40 CFR 60.25a(a) requires that state plans shall include an inventory of all designated facilities, including emissions data for the designated pollutants. This provision further requires that such data shall be summarized in the plan, and emission rates of designated pollutants from designated facilities shall be correlated with applicable standards of performance. While the latest revisions to subpart Ba did alter this provision some, those revisions were not meaningful with respect to the reasoning that the EPA included in the December 2022 Supplemental Proposal for superseding this inventory requirement for the oil and natural gas EG.

The EPA received significant comments regarding the inclusion of an emissions inventory in the state plan submittal. A summary of the comments received and the EPA's response to these comments, including any changes made to the final rule, as applicable are provided below. The EPA's full response to comments on the November 2021 Proposal and December 2022 Supplemental Proposal, including any comments not discussed in this preamble, can be found in the EPA's RTC document for the final rule.⁷¹⁴

⁷¹³ 86 FR 63253.

⁷¹⁴ *Standards of Performance for New, Reconstructed, and Modified Sources: Oil and Natural Gas Sector Climate Review. Response to Public Comments on the November 2021 Proposed Rule and the December 2022 Supplemental*

Comment: Several commenters support the use of existing emissions inventory data to fulfill state plan requirements even if that data might not be fully aligned with the designated facilities in the EG.⁷¹⁵ One commenter⁷¹⁶ suggested that the emissions inventory data could be derived from the GHGRP whereas other commenters⁷¹⁷ did not support the use of GHGRP as a basis for their state inventory data due to the large reporting threshold. Several other commenters supported the EPA's proposal to supersede the requirements of 40 CFR 60.25a(a) so that state plans do not have to include an inventory and emissions data as described.⁷¹⁸ Lastly, one commenter reported that their state regulations require that any source of regulated air pollutants must submit an emission inventory and suggests the EPA accept emissions data for these facilities in accordance with the provisions of the Air Emissions Reporting Requirements (AERR), with detailed requirements for designated facilities that are classified as AERR Type A and B sources and the use of alternative methods (e.g., a nonpoint tool) for designated facilities that would be classified as nonpoint sources under the AERR.⁷¹⁹ The commenter reports that AERR already has emissions thresholds for what should be inventoried as a point source, and what is being captured in the NEI as a nonpoint source. The commenter believes that the rule should align with the AERR thresholds and requirements and suggests that using the NEI would give a much more comprehensive accounting of facilities and provide more accurate emissions.

Response: The EPA maintains that, due to the very large number of existing oil and natural gas sources (designated facilities)⁷²⁰ and the frequent change of configuration and/or ownership, it is not practical to require states to compile this information generally required by subpart Ba in the same way that is typically expected for other industries

Proposed Rule (86 FR 63110, November 15, 2021; 87 FR 74702, December 6, 2022).

⁷¹⁵ See Document ID No. EPA-HQ-OAR-2021-0317-2218, -2286, -2296, -2393, -2410.

⁷¹⁶ See Document ID No. EPA-HQ-OAR-2021-0317-2218.

⁷¹⁷ See Document ID No. EPA-HQ-OAR-2021-0317-2296, -2393.

⁷¹⁸ See Document ID No. EPA-HQ-OAR-2021-0317-2286, -2296.

⁷¹⁹ See Document ID No. EPA-HQ-OAR-2021-0317-2393.

⁷²⁰ In the U.S. the EPA has identified over 15,000 oil and gas owners and operators, around 1 million producing onshore oil and gas wells, about 5,000 gathering and boosting facilities, over 650 natural gas processing facilities, and about 1,400 transmission compression facilities.

under other EG. Furthermore, the EPA believes that, while 40 CFR 60.25a(a) could be superseded to require the use of existing emissions inventory data such as GHGRP or NEI to fulfill state plan requirements, the development of such an inventory would still be resource intensive with little benefit. Specifically, the EPA does not find it reasonable to burden states to derive information from GHGRP, the AERR, or the NEI, which the EPA already has, only to resubmit it to the Agency. Therefore, in order to avoid the potential burden that could be imposed by applying 40 CFR 60.25a(a) as written to this EG, as well as the potential burden and duplicative information collection imposed by requiring states to use other existing inventories such as GHGRP, the EPA finalizes, as proposed, to supersede the requirements of 40 CFR 60.25a(a) for purposes of this EG, so that state plans are not required to include an inventory and emissions data as described under this provision. The EPA further reiterates for purposes of this EG, that the EPA does not find that the inventory and detailed emissions data required under 40 CFR 60.25a(a) is necessary for states to develop standards of performance.

6. Meaningful Engagement

In the November 2021 Proposal and December 2022 Supplemental Proposal, the EPA proposed and solicited comment on a requirement that states perform early outreach and meaningful engagement with pertinent stakeholders during the development process of their state plans pursuant to EG OOOOc.⁷²¹ The EPA is not finalizing the provision for meaningful engagement in this rulemaking. Rather, since similar revisions to subpart Ba are now final and are therefore applicable to the EG OOOOc, state plans must be submitted according to the provisions in 40 CFR 60.23a(i) which requires states to document in their plan submittals how they provided meaningful engagement with the pertinent stakeholders. Specifically, subpart Ba requires as part of completeness criteria in 40 CFR 60.27a(g) that states must submit, with the plan or revision, documentation of meaningful engagement including a list of identified pertinent stakeholders and/or their representatives, a summary of the engagement conducted, a summary of stakeholder input received, and a description of how stakeholder input

⁷²¹ See 86 FR 63254 (November 15, 2021) and 87 FR 74827 (December 6, 2022).

was considered in the development of the plan or plan revisions.⁷²²

Since the EPA has finalized these meaningful engagement provisions within the context of subpart Ba, and since subpart Ba applies to the development of state plans for this EG, the EPA found it unnecessarily redundant to finalize similar provisions related to meaningful engagement in the context of this EG OOOOc. This EG therefore defers to subpart Ba on this topic. However, there are several related issues raised in comments that the EPA will briefly discuss here. First, as discussed in section VII of this preamble, the EPA summarized engagement with pertinent stakeholders for this rulemaking. To the extent that commenters take issue with the EPA's engagement with stakeholders on this rulemaking (the NSPS OOOOb and EG OOOOc), we direct them to section VII of this preamble and the separate RTC document associated with this final rulemaking.

Second, the EPA recognizes that several comments the Agency received on the November 2021 Proposal and the December 2022 Supplemental Proposal referenced several existing state and Tribal nation EJ programs and/or EJ analyses conducted in oil and natural gas producing states and Tribal nations. The EPA compiled information submitted by commenters and documented our review of other readily available information (e.g., state websites) on programs and analyses in a Memorandum to the public docket titled, *Summary of State, Tribal and Local Environmental Justice (EJ) Programs and Analyses*.⁷²³ The EPA believes this memorandum will serve as a helpful resource to states, pertinent stakeholders, and other interested parties trying to determine how to conduct their own meaningful engagement as part of the state planning process. The memorandum specifically describes a summary of existing EJ programs and other EJ activities conducted by state, Tribal, and local governments compiled from an in-depth assessment of government websites and publicly available documents. The EPA identifies state and Tribal EJ programs and procedures, including community identification criteria and mapping tools utilized.⁷²⁴ The EPA observes in the

memorandum that while several states implement tools or procedures for conducting analyses, few of these states include readily available results of analyses their agencies have conducted (i.e., not accessible on their websites or through web searches), and no analyses conducted by tribes were identified. Analyses performed by local government associations for transportation planning purposes were available for review and included in this summary.

Lastly, the EPA further recognizes that several comments the Agency received on the November 2021 Proposal and the December 2022 Supplemental Proposal requested that the EPA be more specific about what the EPA would consider approvable for meaningful engagement and provide guidance to states (e.g., scope and degree). The EPA notes that as part of subpart Ba the EPA finalized procedural requirements for meaningful engagement as completeness criteria and is not prescribing how states proceed with such engagement. In particular, at 40 CFR 60.23a(i), subpart Ba requires that states must submit, with the plan or revision, documentation of meaningful engagement including a list of identified pertinent stakeholders and/or their representatives, a summary of the engagement conducted, a summary of stakeholder input received, and a description of how stakeholder input was considered in the development of the plan or plan revisions. As an additional resource to states, the EPA compiled information that may assist states identify best practices for conducting meaningful engagement. This information can be found in a Memorandum to the public docket for this rulemaking titled, *Summary of Strategies for Meaningful Engagement on Environmental Justice (EJ) Topics*.⁷²⁵ This memorandum reviews over fifty EJ reports, policies, plans, and publications that have been produced by various state and local jurisdictions in the U.S. and the memorandum includes numerous referenced documents that pertinent stakeholders and other interested parties may find helpful.

D. Components of State Plan Submission

Under CAA section 111(d)(2), the EPA has an obligation to determine whether each state plan is "satisfactory." Therefore, in addition to identifying the components that the EG must include, the EPA's implementing regulations⁷²⁶

for CAA section 111(d) (subpart Ba) identify additional components that a state plan must include. Many of these requirements are found in 40 CFR 60.23a, 60.24a, 60.25a, and 60.26a. These provisions include requirements for components such as the following: procedures a state must follow for adopting a plan before submitting it to the EPA; the stringency of standards of performance and compliance timelines; emissions inventories, reporting, and recordkeeping; and a demonstration the state has legal authority to adopt and implement the plan. These requirements are also generally contained in a list of required state plan elements, referred to as the state plan completeness criteria, found at 40 CFR 60.27a(g)(2)–(3). If the EPA determines that a submitted plan does not meet these criteria, then the state is treated as not submitting a plan and the EPA has a duty to promulgate a Federal plan for that state. See CAA section 111(d)(2)(A) and 40 CFR 60.27a(g)(1). If the EPA determines a plan submission is complete, such determination does not reflect a judgment on the eventual approvability of the submitted portions of the plan, which instead must be made through notice-and-comment rulemaking. The completeness criteria do not apply to states without any designated facilities because these states are instead directed to submit to the Administrator a letter of negative declaration certifying that there are no designated facilities, as defined by the EPA's emissions guidelines, located within the state. See 40 CFR 60.23a(b). No plan is required for states that do not have any designated facilities. Designated facilities located in states that mistakenly submit a letter of negative declaration could be subject to a Federal plan until a state plan regulating those facilities becomes approved by the EPA.

Subpart Ba of 40 CFR part 60 contains ten administrative and six technical criteria for complete state plans under CAA section 111(d). See 40 CFR 60.27a(g)(2)–(3). If a state plan does not include one of these established criteria, then the state plan may be deemed incomplete by the EPA. States that are familiar with the SIP submittal process under CAA section 110 will be familiar with the completeness criteria found in 40 CFR part 51, appendix V. While the completeness criteria for state plan submittals found at 40 CFR 60.27a(g)(2)–(3) are somewhat similar to the SIP submittal criteria in appendix V, the criteria are not exactly the same. As such, even states that are familiar with the SIP submittal process under CAA section 110 are strongly encouraged to

⁷²² See 40 CFR 60.21a for the definitions of meaningful engagement and pertinent stakeholders.

⁷²³ See EPA–HQ–OAR–2021–0317.

⁷²⁴ Comments also indicated several EJ studies had been conducted in oil and gas producing states by third parties. The focus of this review was on analyses conducted by state and local governments, although a few third-party analyses were included where information was readily available.

⁷²⁵ See EPA–HQ–OAR–2021–0317.

⁷²⁶ 88 FR 80480 (November 17, 2023).

review the completeness criteria in 40 CFR 60.27a(g)(2)–(3) as well as the other state plan requirements found in 40 CFR 60.23a, 60.24a, 60.25a, and 60.26a early in their planning process.

In short, the administrative completeness criteria require that the state's plan include a formal submittal letter and a copy of the actual state regulations themselves, as well as evidence that the state has legal authority to adopt and implement the plan, actually adopted the plan, followed state procedural laws when adopting the plan, gave public notice of the changes to state law, held public hearing(s) if applicable, and responded to state-level comments. For a detailed description regarding the public hearing requirement, see 40 CFR 60.23a. For a detailed description of what the state plan must include in terms of evidence that the state has legal authority to adopt and implement the plan, see 40 CFR 60.26a. States are strongly encouraged to review the state plan requirements included in 40 CFR 60.23a and 60.26a in conjunction with the administrative completeness criteria in 40 CFR 60.27a. Also, as explained above, the completeness criteria in subpart Ba now requires states to include in their plan submittals how they provided meaningful engagement with the pertinent stakeholders.

The technical criteria require that the state's plan identify the designated facilities, the standards of performance, the geographic scope of the plan, monitoring, recordkeeping and reporting requirements (both for designated facilities to ensure compliance and for the state to ensure performance of the plan as a whole), and compliance schedules. The technical criteria further require that the state demonstrate that the plan is projected to achieve emission performance under the EG and that each emission standard is quantifiable, non-duplicative, permanent, verifiable, and enforceable. As previously described, it may not be feasible to quantify certain non-numerical standards of performance. For a detailed description of the state plan requirements regarding standards of performance, see section XIV.C of this document and 40 CFR 60.24a.

In addition to these technical criteria, 40 CFR 60.25a(a) requires that state plans include certain emissions inventory data for the designated facilities. As explained in section XIII.C.5 of this preamble, the EPA is, in this final action, superseding that requirement for this EG. Further, § 60.25a provides a detailed description of what the state plan is required to

include in terms of certain compliance monitoring and reporting. States are to review the state plan requirements included in 40 CFR 60.24a and 60.25a in conjunction with the technical completeness criteria in 40 CFR 60.27a to ensure their state plan submissions are complete.

In the December 2022 Supplemental Proposal, the EPA proposed to include a provision within EG OOOOc regarding electronic submission of state plans. However, the EPA is not finalizing the provision for electronic submission of state plans in this rulemaking. Rather, since similar revisions to subpart Ba regarding electronic submission are now final and are therefore applicable to the EG OOOOc, state plans and negative declarations must be submitted according to the provisions in 40 CFR 60.23a(3) and (b) respectively. These subpart Ba provisions require the electronic submission of state plans and negative declarations using the State Planning Electronic Collaboration System (SPeCS). As specified in subpart Ba, states are not to transmit CBI through SPeCS.⁷²⁷ The EPA found it unnecessary to also finalize provisions related to electronic submission within EG OOOOc because such provisions would be unnecessarily redundant with those now included in subpart Ba.

E. Timing of State Plan Submission and Compliance Times

1. Background and Subpart Ba

Under CAA section 111(d), each state has an obligation to submit a plan to the EPA that establishes standards of performance for each designated facility. The EPA acknowledged in the November 2021 Proposal that the D.C. Circuit vacated certain timing provisions within the version of 40 CFR part 60, subpart Ba that had been promulgated in 2019. *American Lung Ass'n*, 985 F.3d at 991. See 86 FR 63255 (November 15, 2021). These vacated timing requirements included: the timeline for state plan submissions, the timeline for the EPA to act on a state plan, the timeline for the EPA to promulgate a Federal plan, and the timeline that dictates when state plans must include increments of progress. As a result of the court's vacatur, no regulations governed the timing of these actions at the time the EPA proposed this EG in 2021 and also at the time that the EPA issued the Supplemental Proposal for this EG in 2022.⁷²⁸ In a separate rulemaking in response to the vacatur, the EPA has now finalized new

⁷²⁷ 88 FR 80480 (November 17, 2023).

⁷²⁸ The court did not vacate the applicability provision for subpart Ba under 40 CFR 60.20a(a).

timelines in subpart Ba for purposes of the implementing regulations.⁷²⁹ These deadlines in subpart Ba are intended to apply generally to actions implementing EG promulgated after July 8, 2019, under CAA section 111(d), including to the EPA's action on state plan submissions and promulgation of a Federal plan under the final EG OOOOc which are further discussed in XIII.F.

In the December 2022 Supplemental Proposal,⁷³⁰ for purposes of EG OOOOc, the EPA proposed to require that each state adopt and submit to the Administrator, within 18 months after publication of the final EG OOOOc, a plan for the control of GHGs in the form of limitations on methane to which EG OOOOc applies. The EPA also proposed a uniform compliance timeline to be as expeditiously as practicable, but no later than 36 months following the state plan submittal deadline. Lastly, the EPA proposed two increments of progress. The first increment of progress was the submission of a final control plan by owners and operators within 2 years after the deadline for the state plan submittals. The second increment of process proposed was a notification of final compliance report for each designated facility on or before 60 days after the compliance date of the state plan. The EPA proposed that for the notification of final compliance report, a company would be allowed to submit one notification that covers all of the company's designated facilities in a state in lieu of submitting a notification for each designated facility.

The EPA received comments regarding the timing of the state plan submission deadline and the compliance times. A summary of the comments received and the EPA's response to these comments, including any changes made to the final EG, as applicable are provided below. The EPA's full response to comments on the November 2021 Proposal and December 2022 Supplemental Proposal, including any comments not discussed in this preamble, can be found in the EPA's RTC document for the final rule.⁷³¹

2. Timing of State Plan Submission

Within the December 2022 Supplemental Proposal, the EPA proposed to require that each state

⁷²⁹ 88 FR 80480 (November 17, 2023).

⁷³⁰ See 87 FR 74831 (December 6, 2022).

⁷³¹ *Standards of Performance for New, Reconstructed, and Modified Sources and Emissions Guidelines for Existing Sources: Oil and Natural Gas Sector Climate Review. Response to Public Comments on the November 2021 Proposed Rule and the December 2022 Supplemental Proposed Rule* (86 FR 63110, November 15, 2021; 87 FR 74702, December 6, 2022).

adopt and submit to the Administrator, within 18 months after publication of the final EG OOOOc, a plan for the control of GHGs in the form of limitations on methane to which EG OOOOc applies. The EPA received many comments on this proposed timeline, and is finalizing a slightly extended deadline of 24 months after publication of the final EG OOOOc.

Comments: A large number of state commenters in addition to other commenters expressed that the EPA's proposed 18-month state plan submission deadline would not provide adequate time for state plan development and state administrative processes for adopting a plan to regulate designated facilities.⁷³² The commenters cite several concerns with the timeframe proposed. The commenters request that the EPA consider the impracticability of the criteria established in 40 CFR 60.5365c of the proposed regulatory text for EG OOOOc and afford states greater flexibility to effectively develop a state plan. Specifically, a few commenters⁷³³ outlined factors that affect the time needed for states to develop and submit a plan to the EPA including the volume of sources, limited air regulatory experience of sources, time necessary to create an accurate source inventory, the proper notification to those sources and information requests from sources, the possible need for permit development, time needed for meaningful engagement and public participation, time needed to adopt any regulatory changes that would be necessary before submitting a state plan, time needed to develop and draft plans that include the required components, and time needed for adoption of the plans through their required administrative processes before submitting them to the EPA. Other commenters stated similar points and suggested that the 18-month timeframe would be inadequate for source-by-source equivalency determinations, and that states with a greater number of production wells (particularly low-producing wells) will need additional time.⁷³⁴ The same commenters argue that even if states were to simply adopt the presumptive standards as proposed, the 18-month timeline would not provide states with sufficient time for meeting the requirements. They criticize the Agency for proposing the 18-month timeframe when the EPA itself has taken

much longer to propose and finalize a FIP for the Uinta Basin ozone NAAQS. One state commenter asks that the EPA grant states with a substantial number of covered sources additional time as needed.⁷³⁵ The commenter expresses concern with regards to the significant workload and impact on the state resources, making it difficult to complete a state plan in 18-month timeframe. Several other commenters discuss the lengthy state administrative process and the need for adequate time to assess any RULOF considerations.⁷³⁶ Specifically, they argue in order to consider remaining useful life of a source in a state plan submission, states must be able to determine the compliance timeline by considering factors such as the source's anticipated retirement date, costs and benefits of an available technology, and technology that has already been deployed which they believe would necessitate additional time for these analysis.

Specifically with regards to meaningful engagement, commenters discuss that the additional requirement of meaningful engagement that, as proposed, would have required additional outreach beyond what states typically conduct during a routine rulemaking and state CAA section 111(d) plan development taking consequential time and resources required to fulfill those obligations to ensure state plan completeness.⁷³⁷ The commenter highlights the coordination that may be needed for meaningful engagement between a state, the EPA, and Tribal nations to address shared and neighboring jurisdictions. One commenter provides further details on the level of effort and time needed based on their experience of developing other state rules.⁷³⁸ According to the commenter, their state rulemaking process requires an internal draft development phase, numerous outreach meetings to stakeholders, and two Air Quality Advisory Board meetings. At the Air Quality Advisory Board meeting for one proposal, the state agency received significant comment that prompted additional review and revisions, and an Environmental Quality Council hearing. The commenter indicated this process took more than 18 months for development, stakeholder engagement, and statutory process while emphasizing that their example only

addressed a subset of sources in one region of the state and that the work necessary to implement the EG will affect designated facilities statewide and will entail greater effort and need additional time. The commenter states that it would appear that the only workable option to states would be to adopt the model rule in the EG, which they argue denies states their legal right to consider a source's RULOF as established by the CAA.

Some commenters provide a general recommendation for a minimum 24-month timeline for state plan development and submission but many suggest a need provide for additional extensions for RULOF and for engagement with pertinent stakeholders.⁷³⁹ They tally the needed time to upwards of 3 years to complete state plan development.⁷⁴⁰

On the contrary, other stakeholders argue that 18 months is too long.⁷⁴¹ One commenter suggests that 6 to 12 months would be adequate time for states to submit their state plans.⁷⁴² Other commenters urge the EPA to defer to the timeframe provided in the implementing regulations (subpart Ba).⁷⁴³ The commenters contend that the EPA did not provide adequate evidence in the December 2022 Supplemental Proposal, or the proposed implementing regulations under subpart Ba, to suggest that state-level administrative processes are different for designated facilities in the crude oil and natural gas source category than for any other source category, and so offers no reason why the proposed 18 months, rather than 15 months proposed in subpart Ba, are necessary to accommodate state plan development in this category. The commenter challenges the EPA's reasoning that EG OOOOc necessitates a longer timeframe due to the size and variety of emission sources in the source category.⁷⁴⁴ The commenter notes that this justification appears nowhere in the EG OOOOc preamble itself and does not support an 18-month rather than 15-month submission period in any event. The commenter further asserts that given the urgent nature of climate change, the EPA must ensure that its proposed EG

⁷³² Document ID Nos. EPA-HQ-OAR-2021-0317-2157, -2220, -2222, -2224, -2237, -2241, -2292, -2296, -2310, -2322, -2330, -2393, -2403, -2410, -2418, -2446.

⁷³³ Document ID Nos. EPA-HQ-OAR-2021-0317-2330, -2403.

⁷³⁴ Document ID Nos. EPA-HQ-OAR-2021-0317-2446, -2241.

⁷³⁵ Document ID Nos. EPA-HQ-OAR-2021-0317-2296, -2220.

⁷³⁶ Document ID Nos. EPA-HQ-OAR-2021-0317-2220, -2237, -2393.

⁷³⁷ Document ID Nos. EPA-HQ-OAR-2021-0317-2220, -2222, -2393, -2241.

⁷³⁸ Document ID No. EPA-HQ-OAR-2021-0317-2220.

⁷³⁹ Document ID Nos. EPA-HQ-OAR-2021-0317-2157, -2220, -2296, -2330, -2410, -2418.

⁷⁴⁰ Document ID Nos. EPA-HQ-OAR-2021-0317-2222, -2225, -2237, -2241, -2310, -2322, -2393, -2403.

⁷⁴¹ Document ID Nos. EPA-HQ-OAR-2021-0317-2201, -2433.

⁷⁴² Document ID No. EPA-HQ-OAR-2021-0317-2201.

⁷⁴³ Document ID Nos. EPA-HQ-OAR-2021-0317-2392, -2433.

⁷⁴⁴ 87 FR 79181.

OOOOC are implemented as swiftly as possible. The commenter urges the EPA to apply the proposed default 15-month timeline for state plan submissions proposed in subpart Ba under EG OOOOC rather than the extended 18-month period.

Response: The proposed 18-month submittal timeline the EPA proposed for EG OOOOC was based on the EPA's proposed determination that this was a reasonably expeditious deadline that would provide states sufficient time to develop and submit an approvable state plan. After evaluation of the comments received, the EPA agrees with commenters that additional time is warranted for the state plan submittal for EG OOOOC. The EPA disagrees with commenters claiming that substantially less time would be adequate time for states to submit complete state plans. The EPA clarifies that while state-level administrative processes are not different for designated facilities in the crude oil and natural gas source category than for any other source category, there are numerous reasons why the EPA believes it is appropriate to supersede the state plan submittal timeframe of the subpart Ba implementing regulations in EG OOOOC. Furthermore, in the December 2022 Supplemental Proposal (87 FR 74831 to 74835), the EPA discussed its considerations with respect to the characteristics and unique nature of the crude oil and natural gas source category in comparison to other EG. In response to comments on this discussion, the EPA provides further explanation.

When developing a state plan submittal, the requirements of the recently finalized subpart Ba apply. This subpart imposes baseline requirements that the state must meet when developing its state plan in response to this EG OOOOC. Meeting those requirements takes time. There are also state-specific processes applicable to the development and adoption of a state plan, including the administrative processes (e.g., permitting processes, regulatory development, legislative approval) necessary to develop and adopt enforceable standards of performance. State plan development generally involves several phases, including providing notice that the state agency is considering adopting a rule; taking public comment; and approving or adopting a final rule. The process required to formally adopt a rule at the state level differs from state to state.

Moreover, there are several recently added requirements in subpart Ba (for example, meaningful engagement) that states may be undertaking for the first

time when developing their state plan submission in response to the final oil and natural gas EG. Further, the EPA generally agrees with commenters that meeting the requirements of subpart Ba within the context of their state plan submittal for EG OOOOC require time. For example, there are many diverse stakeholders who have equities and interests in how this industry is regulated. These stakeholders may submit many complex comments to the state during the state's plan development process. The EPA received over 470,000 comments on the November 2021 Proposal and over 515,000 comments on the December 2022 Supplemental Proposal. While it would be unusual for a state plan to garner this same number of comments as a national rulemaking, it is nonetheless reasonable to assume these larger than typical number of comments are an indication of the increased level of interest that state plans are likely to receive. Since the state is required to include responses to comments received in their state plan submittal, development of plans for this EG could take longer than typical. Subpart Ba, 60.27a(g)(2)(viii).

In addition to the baseline requirements of subpart Ba, these EG also impose unique circumstances to consider on states. For example, the EPA explained in the December 2022 Supplemental Proposal that EG OOOOC has the potential to require states to perform considerable engineering and/or economic analyses for their plan. For purposes of these EG, states will be required to establish standards of performance for nine different types of designated facilities, of which three have numerical limits and six are in the format of non-numerical standards. The designated facilities are also geographically spread out covering multiple industry segments. If a state wishes to utilize the flexibilities explained in section XIII.C.2 of this preamble related to leveraging an existing state program, determining equivalency, and/or averaging, then the requisite analysis can be time consuming. Contrary to some commenters' assertions, the EPA explained these concerns at 87 FR 74833 and 74834 of the December 2022 Supplemental Proposal. Those commenters that suggest that states need less time to submit plans did not appear to address these concerns that the EPA expressed or the requirements of state laws governing the development and submission of plans. We still find these to be compelling reasons to allow the

states even more time to develop and submit their plans for this EG.

Therefore, the EPA is superseding the timeline included in subpart Ba and is finalizing 24 months for the timing of the state plan submissions for purposes of EG OOOOC. The EPA believes that 24 months from the time the EG is published will be adequate to complete state administrative processes, conduct public hearings, engage with pertinent stakeholders, and meet all other applicable requirements of subpart Ba. This timeline represents a reasonable balance between providing states sufficient time to develop and submit a plan that satisfies the applicable requirements and ensuring that the emission reductions contemplated in an EG are achieved as expeditiously as practicable. While the EPA recognizes that states need time to follow their state-specific processes and laws, we are also aware from the Agency's experience with SIPs that some states have adopted, or may adopt, procedures that are longer than necessary and that could delay Federal emission-reduction obligations. Extending the state plan submittal deadline beyond 24 months to account for any and all unique state procedures would inappropriately delay reductions in emissions that have been found under CAA section 111 to endanger health or the environment. The timeline of 24 months strikes an appropriate balance for this EG between the state's need for time and the EPA's responsibility to ensure expeditious implementation in consideration of the important benefits of the pollution reductions. This balance also comports with the court's reasoning in *American Lung Ass'n* (985 F.3d 914 (D.C. Cir. 2021)).

Furthermore, the EPA finds that 24 months will accommodate the challenges commenters identified and help ensure states have the time to ensure their plans are complete and approvable to ensure that the EG will be timely implemented given the urgent need of climate change. The EPA recognizes that the recent revisions to subpart Ba include a state plan submittal timeline of 18 months. To avoid any potential confusion, the EPA is clarifying that the state plan submittal timeline of 24 months being finalized in this action for EG OOOOC supersedes the default timeline in subpart Ba, but only for purposes of those state plans submitted in accordance with this EG OOOOC.

3. Compliance Timelines

Within the November 2021 Proposal, the EPA proposed to require that state plans require designated facilities to

come into full compliance with the applicable standards of performance as expeditiously as practicable, but no later than 2 years following the state plan submittal deadline. Based on comments received on the November 2021 Proposal, the EPA extended this timeline to 36 months in the December 2022 Supplemental Proposal (87 FR 74835–74837). The EPA is finalizing the compliance timeline of 36 months from the deadline for state plan submittals.

Comments: Numerous commenters express concern that the proposed 36-month compliance timeline does not provide adequate implementation time for owners and operators to accomplish successful emission reductions for the tens of thousands of facilities.⁷⁴⁵ Commenters highlight constraints on equipment supplies particularly for converting to zero-emissions equipment for process controllers and pumps. The commenters believe that the scope and breadth of the EG will exacerbate existing delays in acquiring equipment on such a large scale. One commenter articulates that more time is needed to account for the cumulative burden of the multiple actions that the EPA is finalizing, and that owners and operators need time to understand how all the rules are intended to interact together.⁷⁴⁶

Some commenters recommend that the EPA establish a final compliance timeline that begins with the date of the EPA's approval of the state plan rather than the state plan submission date.⁷⁴⁷ Other commenters state that the final compliance date should be no less than the proposed 36-month timeline.⁷⁴⁸ One commenter adds that states and operators are ill-equipped and unprepared to comply with the EG.⁷⁴⁹ For example, the commenter states that certain presumptive standards, like fugitive emissions monitoring requirements, have a regulatory framework that is dependent on component counts which is different than how some states or existing sources have tracked their facilities, so time is needed to understand and establish a new framework for tracking regulatory requirements. The commenter furthermore stresses that states have considerable staffing shortages and that it will take additional time for

designated facilities and states to process necessary reporting requirements or updating of permits.

Other commenters take the opposite position. One commenter states that designated facilities should not receive additional compliance time at the expense of the public interest in pollution reduction, and urges the EPA to require accelerated compliance in states with higher methane emissions from designated facilities.⁷⁵⁰ Several other commenters suggest that for standards that do not require the installation of new equipment, the compliance timeline should be accelerated.⁷⁵¹ They identify that designated facilities other than oil wells with associated gas, storage vessels, process controllers, and pumps, such as alternative leak detection programs, should be placed on faster compliance timelines. According to commenters, fugitive and leak detections programs and alternative leak detection programs can be implemented relatively quickly and inexpensively as compared to equipment retrofits. They believe that the EPA has failed to justify why such a lengthy compliance period would be necessary for these types of sources. The commenter adds that the desire to simplify compliance and ease the burden on industry operators is not a valid basis for this timeframe under the statute and not warranted by these circumstances. Furthermore, they argue that leak detection standards are not impacted by supply chain and logistical issues in the same way as standards requiring equipment procurement and possible shutdowns of designated facilities, such as standards for process controllers, pumps, and storage vessels. The commenters suggest a shortened timeline for compliance for these facilities of no more than 6 months to 1 year after the EPA's approval of a state plan.

Commenters advocating for an earlier compliance timeline for some sources identify the advantages of phasing-in leak detection programs for EG OOOO and recommend incentivizing earlier compliance. For example, the commenter asks the EPA to consider incentivizing a separate, earlier phase-in period for control strategies that do not involve significant capital expenditures or retrofits which could be used to balance emissions from areas of the rule that may require additional time to implement. The commenters suggest the EPA consider adopting a shorter

timeline than proposed, such as 24 to 30 months after plan submission deadlines, for sources that do not require capital expenditures for compliance. Another commenter recommends that the EPA reconsider whether to accelerate the timeline for compliance for specific performance standards.⁷⁵² The commenter notes that the EPA should reconsider whether the benefits of the proposed three-year uniform deadline may be overstated and whether the urgency of the health and environmental harms that state plans will address merits a shorter deadline for compliance to increase net benefits for society. According to the commenter, the EPA has given some consideration to the need for expeditious compliance, but given the December 2022 Supplemental Proposal's significant health and environmental benefits, the EPA should reevaluate the feasibility of a more aggressive compliance schedule that would allow these benefits to be realized sooner. The commenter recommends that to select which standards of performance merit an earlier compliance deadline, the EPA should apply the nine factors that the EPA identified for this purpose in the December 2022 Supplemental Proposal (e.g., supply-chain issues).⁷⁵³ However, in lieu of the existing second and ninth factors (“[t]he cost of equipment” and “overall methane emissions reduction that will result from control of existing sources under the [emissions guideline]”), the commenter suggests that it would be preferable to examine net benefits. Compared to methane emissions reductions alone, looking to net benefits would allow for consideration of all relevant costs and benefits—including benefits from methane's co-pollutants emitted along with methane—when evaluating whether to prioritize compliance with one standard of performance over another. The commenter continues that, the nine factors indicate that the EPA should substantially shorten the timeline for existing sources to comply with the super-emitter response program. The EPA's concerns about the costs of simultaneous implementation across the sector and planning burdens do not apply to this program. For the same reasons that 14 days is too long to wait before acting on a single super-emitter event, the commenter states that 3 years is too long to wait for the entire program. The commenter suggests that, in instances where the EPA has

⁷⁴⁵ Document ID Nos. EPA–HQ–OAR–2021–0317–2288, –2237, –2296, –2403, –2423.

⁷⁴⁶ Document ID No. EPA–HQ–OAR–2021–0317–2423.

⁷⁴⁷ Document ID Nos. EPA–HQ–OAR–2021–0317–2403, –2446.

⁷⁴⁸ Document ID Nos. EPA–HQ–OAR–2021–0317–2288, –2237.

⁷⁴⁹ Document ID No. EPA–HQ–OAR–2021–0317–2304.

⁷⁵⁰ Document ID No. EPA–HQ–OAR–2021–0317–1659.

⁷⁵¹ Document ID Nos. EPA–HQ–OAR–2021–0317–2028, –2284, –2392, –2410, –2433.

⁷⁵² EPA–HQ–OAR–2021–0317–2343.

⁷⁵³ See Table 38 in the December 2022 Supplemental Proposal at 87 FR 74835.

differentiated between subcategories of affected facilities, the EPA should further consider accelerating compliance for select subcategories if doing so appears more net beneficial than subjecting all designated facilities to the same deadline. The commenter provides that staggering compliance across tiers within a single EG could reduce the planning burden on entities in a given year and help prevent bottlenecks for specialized equipment and services by spreading compliance deadlines out over time. For instance, the commenter points out the consideration of fugitive emissions at wells, a category that the EPA already divides into four tiers with different monitoring requirements based on the number of wells at the site and the presence of major equipment. The commenter states that the EPA could apply the same nine factors discussed above to designate one or more tiers of wells subject to an accelerated compliance timeline. The commenter adds that the EPA could conduct a similar assessment for its four potential subcategories for pneumatic controllers (well sites, gathering and boosting stations, transmission and storage compressor stations, and natural gas processing plants). The commenter notes that this tiering of compliance deadlines may increase net benefits relative to waiting 3 years for all four tiers because a subset of the December 2022 Supplemental Proposal's benefits would be achieved sooner and thus accrue over the additional time. While annual costs would also accrue over the additional time, the commenter believes that the benefits would most likely exceed the costs to the same extent as they are projected to do so for future years.

Response: The EPA disagrees with the comments suggesting additional time is necessary. When the compliance timeline of 36 months is considered in conjunction with the state plan submittal deadline of 24 months, that means that sources could have up to 5 years between when the EG are final and when they are required to fully comply with the applicable standards of performance. The EPA believes that any concerns with possible equipment or staffing shortages, which commenters speculate could be an issue, would likely be addressed by industry and regulators in that timeframe. The EPA did evaluate the types of factors that commenters raised, as explained in the December 2022 Supplemental Proposal (87 FR 74835, table 38). After re-considering these factors in conjunction with the comments received on the

December 2022 Supplemental Proposal, the EPA still finds that 36 months is appropriate because commenters did not present the EPA with convincing information to suggest that the assumptions made in the 2022 Supplemental Proposal were inaccurate.

The EPA agrees to a certain extent with some comments that suggest the Agency could have taken a different approach wherein we could have established different compliance timelines for different types of designated facilities. The EPA discussed this consideration in the December 2022 Supplemental Proposal at 87 FR 74836. After considering comments, the EPA still believes that it is appropriate to finalize a uniform outermost compliance deadline for purposes of these EG. In addition to the reasoning for preferring uniformity and easing burden explained in the December 2022 Supplemental Proposal, which the EPA believes to still hold true (and which commenters do not appear to take direct issue with), the EPA believes that many of the issues raised by commenters could be more appropriately addressed by states during plan development. The EPA highlights that this compliance deadline included in the final EG represents the furthest date into the future that the EPA finds appropriate for a state to allow as a final compliance deadline for the state's standards of performance. Put another way, the 36-month timeline is the most time that the EPA believes a state will need to allow for sources to come into compliance. However, states are free to establish compliance timelines within their state plan submittals for certain designated facilities that are shorter than 36 months, and indeed states should be examining shorter timelines as a possibility to ensure that sources come into compliance with their respective standards of performance as expeditiously as practicable. Subpart Ba is clear that "final compliance shall be required as expeditiously as practicable, but no later than the compliance times specified in an applicable subpart of this part." By finalizing the outermost compliance deadline of 36 months, the EPA is not suggesting that it is necessarily appropriate for *all* compliance timelines in *all* state plans to be set at 36 months. On the contrary, states must require designated facilities to come into final compliance with their standards of performance "as expeditiously as practicable." The time needed for particular groups of existing sources to come into full compliance with a state's standards depends on many factors including the specifics of

that yet-to-be-determined standard as well as the preexisting regulatory framework, if any. The EPA cannot account for all these possible variables when establishing these EG, but states can, and should, account for specific circumstances in their state plans because they will have the relevant facts available to them when developing their state plan submittals.

F. The EPA's Action on State Plans and Promulgation of Federal Plans

The EPA finalized deadlines for its action on state plan submissions and for promulgation of a Federal plan in a separate rulemaking for the implementing regulations (subpart Ba).⁷⁵⁴ See 40 CFR 60.27a. Unless superseded by a particular EG, the subpart Ba deadlines apply generally to all EG promulgated after July 8, 2019, under CAA section 111(d), and also apply to the EPA's action on state plan submissions and promulgation of a Federal plan under the final EG. The EPA is not superseding the deadlines in the final oil and natural gas EG OOOOc. As such, the deadlines included in the final revisions for subpart Ba for the EPA action on a state plan submit and for promulgation of a Federal plan apply in the context of this EG.

As discussed in the November 2021 Proposal and December 2022 Supplemental Proposal, it was not necessary for the EPA to propose deadlines for the EPA's action on state plans submitted in response to a final EG OOOOc, or for the promulgation of a Federal plan where a state fails to submit an approvable plan, as part of the November 2021 Proposal or December 2022 Supplemental Proposal, because these deadlines are not relevant to states in the development of their plans. Additionally, as described in section XIII.E of this document, the EPA proposed and is finalizing in EG OOOOc the final compliance schedule for designated facilities to run from the deadline for state plan submissions.

The EPA subsequently provides this process information for stakeholder awareness. While CAA section 111(d)(1) authorizes states to develop state plans that establish standards of performance and provides states with certain discretion in determining the appropriate standards, CAA section 111(d)(2) provides the EPA a specific oversight role with respect to such state plans. CAA section 111(d)(2) authorizes the EPA to prescribe a Federal plan for a state "in cases where the state fails to submit a satisfactory plan." The states must therefore submit their plans to the

⁷⁵⁴ 88 FR 80480 (November 17, 2023).

EPA, and the EPA must evaluate each state plan to determine whether each plan is “satisfactory.” The EPA’s implementing regulations for CAA section 111(d) accordingly provide procedural requirements for the EPA to make such a determination. See 40 CFR 60.27a.

Upon receipt of a state plan, the EPA is first required to determine whether the state plan submittal is complete in accordance with the completeness criteria explained above. See 40 CFR 60.27a(g). Per the finalized amendments to subpart Ba, the EPA has 12 months to act on a state plan after the plan is deemed complete. *Id.* at 60.27a(b). If the EPA determines that the state plan submission is incomplete, then the state will be treated as not having made the submission, and the EPA would be required to promulgate a Federal plan for the designated facilities in that state within 12 months. Likewise, if a state does not make any submission by the applicable deadline for state plan submissions, then the EPA is required to promulgate a Federal plan within 12 months. If the EPA does not make an affirmative determination regarding completeness of the state plan submission within 60 days of receiving the submittal, then the submission is deemed complete by operation of law.

If a state has submitted a complete plan, then the EPA is required to evaluate that plan submission for approvability in accordance with the CAA, the EPA’s implementing regulations, and the applicable EG. The EPA may approve or disapprove the state plan submission in whole or in part. See 40 CFR 60.27a(b). If the EPA approves the state plan submission, then that state plan becomes Federally enforceable. If the EPA disapproves the required state plan submission, in whole or in part, then the EPA is required to promulgate a Federal plan for the designated facilities in that state via a notice-and-comment rulemaking, and with an opportunity for public hearing. In the case of a disapproval, the scope of the disapproval (in whole or in part) defines the scope of the EPA’s duty to issue a Federal plan. The EPA will also promulgate a Federal plan if a state fails to submit a plan by the state plan submission deadline and if a state submission is determined to be incomplete. See 40 CFR 60.27a(c) and (f). The EPA would not be required to promulgate the Federal plan if the state corrects the deficiency giving rise to the EPA’s duty and the EPA approves the state’s plan before promulgating the Federal plan. Requirements regarding the content of a Federal plan are included in 40 CFR 60.27a(e).

G. Tribes and the Planning Process Under CAA Section 111(d)

Under the TAR adopted by the EPA, Tribes may seek authority to implement a plan under CAA section 111(d) in a manner similar to a state. See 40 CFR part 49, subpart A. Tribes may, but are not required to, seek approval for treatment in a manner similar to a state for purposes of developing a TIP implementing the EG. If a Tribe obtains approval and submits a TIP, the EPA will generally use similar criteria and follow similar procedures as those described above for state plans when evaluating the TIP submission, and will approve the TIP if appropriate. The EPA is committed to working with eligible Tribes to help them seek authorization and develop plans if they choose. Tribes that choose to develop plans will generally have the same flexibilities available to states in this process. If a Tribe does not seek and obtain the authority from the EPA to establish a TIP, the EPA has the authority to establish a Federal plan under CAA section 111(d) for areas of Indian country where designated facilities are located. A Federal plan would apply to all designated facilities located in the areas of Indian country covered by the Federal plan unless and until the EPA approves an applicable TIP applicable to those facilities.

XIV. Use of Optical Gas Imaging in Leak Detection (Appendix K) and Response to Significant Comments

A. Summary of Requirements

In this action, the EPA is finalizing a protocol for the use of OGI as appendix K to 40 CFR part 60. The EPA notes that while this protocol is being finalized in this action, the applicability of the protocol is broader. The protocol is applicable to facilities when specified in a referencing subpart to help determine the presence and location of leaks; it is not currently applicable for use in direct emission rate measurements from sources. The protocol does not on its own apply to any sources; it applies only where a specific rule subpart incorporates it by reference and specifies the sources to which it applies. In this case, we are finalizing the use of the protocol only for implementing the standards for process units at natural gas processing plants that are being finalized in this action.

Once incorporated into a subpart, the protocol would only be applicable for surveys of process equipment using OGI cameras where the majority of compounds (>75 percent by weight) in the emissions streams have a response factor of at least 0.25 when compared to

the response factor of propane.

Additionally, the OGI camera used for surveying must also be capable of detecting (or producing a detectable image of) methane emissions of 19 g/hr and either butane emissions of 29 g/hr or propane emissions of 22 g/hr at a viewing distance of 2.0 meters and a delta-T of 5.0 °C in an environment of calm wind conditions around 1.0 meter per second or less. Verification that the OGI camera meets these criteria may be performed by the owner or operator, the camera manufacturer, or a third party.

Field conditions, such as the viewing distance to the component to be monitored, wind speed, ambient air temperature, and the background temperature, have the potential to impact the ability of the OGI camera operator to detect a leak. Because it is important that the OGI camera has been tested under the full range of expected field conditions in which the OGI camera will be used, an operating envelope must be established for field use of the OGI camera. Imaging must not be performed when the conditions are outside of the developed operating envelope. Operating envelopes are specific to each model of OGI camera and can be developed by the owner or operator, the camera manufacturer, or a third party. To develop the operating envelope, methane gas is released at a set mass rate and wind speed, viewing distance, and delta-T (the temperature differential of the background and the released gas) are all varied to determine the conditions under which a leak can be imaged. For purposes of developing the operating envelope, a leak is considered able to be imaged if three out of four observers can see the leak. Once the operating envelope is developed using methane, the testing is repeated with either butane or propane gas. The operating envelope for the OGI camera is the more restrictive operating envelope developed between the different test gases. The operating envelope must be confirmed for all potential configurations that could impact the detection limit of the OGI camera.

In cases where an operating envelope has not yet been established for an OGI camera model or an OGI camera operator needs to expand an operating envelope to account for site-specific conditions, the OGI camera operator can conduct a daily field check for maximum viewing distance prior to conducting the monitoring survey. The daily field check must be conducted for each OGI camera operator who will conduct the monitoring survey using the OGI camera (and each camera configuration) they will use to complete

the monitoring survey. The daily field check must be performed using the same gases and flow rates used for setting the operating envelope and initial verification check. The maximum viewing distance for the day for the OGI camera operator will be the farthest viewing distance where the OGI camera operator is able to visualize a leak of both test gases. A complete video record, as well as documentation of the delta-T, wind speed, and viewing distance, must be retained for the daily field check. If the delta-T in the field decreases below the delta-T that was recorded for the daily field check or if the wind speed increases above the wind speed recorded for the daily field check, the maximum viewing distance determination must be repeated for the new delta-T and wind speed conditions. A description of how the OGI camera operator will monitor viewing distance, delta-T, and wind speed must be included in the monitoring plan.

Each site must have a monitoring plan that describes the procedures for conducting a monitoring survey. One monitoring plan can be used for multiple sites, as long as the plan contains the relevant information for each site. The monitoring plan must contain procedures for a daily verification check, ensuring that the monitoring survey is performed only when conditions in the field are within the operating envelope, monitoring all the components regulated by the referencing subpart within the unit or area, viewing the components with the camera, how the operator will ensure an adequate delta-T is present in order to view potential gaseous emissions, operator rest breaks, documenting surveys, and quality assurance.

The EPA is finalizing requirements to view each component from at least two different angles. The OGI camera operator must dwell on each angle for a minimum time, where dwell time is defined as the time the scene is steady and in focus and the operator is actively viewing the scene. For a simple scene consisting of 10 or fewer components, the camera operator must dwell for a minimum of 10 seconds per angle. For a scene with greater than 10 components, the camera operator must dwell for a minimum of 2 seconds per component in the field of view.

Each facility or company performing OGI surveys must have a training plan which ensures and monitors the proficiency of the OGI camera operators. If the facility does not perform its own OGI monitoring, the facility must ensure that the training plan for the company performing the OGI surveys adheres to this requirement. Appendix K

prescribes a multi-faceted approach to training. Training includes classroom instruction (either online, remotely, or at a physical location) both initially and biennially on the OGI camera and external devices, monitoring techniques, best practices, process knowledge, and other regulatory requirements related to leak detection that are relevant to the facility's OGI monitoring efforts. Prior to conducting monitoring surveys, camera operators must demonstrate proficiency with the OGI camera. The initial field training includes a minimum of 30 survey hours with OGI where trainees first observe the techniques and methods of a senior OGI camera operator and then eventually perform monitoring surveys independently with a senior OGI camera operator present to provide oversight. The trainee must then pass a final monitoring survey test of at least 2 hours. If there are 10 or more leaks identified by the senior OGI operator, the trainee must achieve less than 10 percent missed persistent leaks relative to the senior OGI camera operator to be considered authorized for independent survey execution. If there are less than 10 leaks identified by the senior OGI operator, the trainee must achieve zero missed persistent leaks relative to the senior OGI camera operator to be considered authorized for independent survey execution. If the trainee doesn't pass the monitoring survey test, the senior OGI camera operator must discuss the reasons for the failure with the trainee and provide instruction/correction on improving the trainee's performance, following which the trainee may repeat the final test.

Performance audits for all OGI camera operators must occur on a quarterly basis and can be conducted either by comparative monitoring or video review by a senior OGI camera operator. If the senior OGI camera operator finds that the survey techniques during the video review do not match those described in the monitoring plan, then the camera operator being audited will need to be retrained. Additionally, if there are 10 or more leaks identified by the senior OGI operator, the camera operator being audited must achieve less than 10 percent missed persistent leaks relative to the senior OGI camera operator. If there are less than 10 leaks identified by the senior OGI operator, the camera operator being audited must achieve zero missed persistent leaks relative to the senior OGI camera operator. Retraining consists of a discussion of the reasons for the failure with the OGI operator being audited and techniques to improve performance; a minimum of 16 survey training hours; and a final

monitoring survey test. If an OGI operator requires retraining in two consecutive quarterly audits, the OGI operator must repeat the initial training requirements.

Previous experience with OGI camera operation can be substituted for some of the initial training requirements. OGI camera operators with previous classroom training (either at a physical location or online) that covers the majority of the elements required by the initial classroom training required in appendix K prior to the publication date of this final rule do not need to complete the initial classroom training, but if the date of certification is more than 2 years before the publication date of the final rule, the biennial classroom training must be completed in lieu of the initial classroom training. OGI camera operators who have 40 hours of experience over the 12 calendar months prior to the date of publication of the final rule may substitute the retraining requirements, including the final monitoring survey test, for the initial field training requirements.

Appendix K requires records to be retained in hard copy or electronic form. Records include the site monitoring plan, operating envelope limitations, data supporting the initial OGI camera performance verification and development of the operating envelope, the training plan for OGI camera operators, OGI camera operator training and auditing records, records necessary to verify senior OGI camera operator status, monitoring survey records, quality assurance verification videos for each operator, and maintenance and calibration records. Some of the records required by the proposed appendix K are not required to be kept onsite as long as the owner or operator can easily access these records and can make the records available for review if requested by the Administrator.

B. Changes Since Supplemental Proposal

This section of this preamble presents a summary of significant comments received on the EPA's protocol for the use of OGI in leak detection being finalized as appendix K to 40 CFR part 60 (referred to hereafter as appendix K) and the EPA's response to those comments. This section also presents changes that have been made to appendix K since the December 2022 Supplemental Proposal.

1. Dwell Time

Comment: Several commenters suggested that the dwell time requirement in appendix K should be

removed.⁷⁵⁵ The commenters felt that the dwell time requirements were overly restrictive, and dwell time should be left to the discretion of the trained operator. One commenter⁷⁵⁶ stated that the proposed viewing requirements would increase survey time approximately four-fold. Commenters were also critical of the proposed allowance for reduction of the dwell time for complex scenes based on the monitoring area and number of components according to table 14–1 of appendix K.⁷⁵⁷ These commenters argued that dwell times and angles are unnecessary, burdensome, and impractical to implement.

Some commenters provided suggestions for alternative dwell times. One commenter⁷⁵⁸ suggested that a minimum of 3 seconds per scene would be appropriate, while another commenter⁷⁵⁹ recommended a maximum dwell time of 5 seconds per angle of view for scenes with multiple components. A third commenter⁷⁶⁰ suggested that scenes be differentiated according to the number of components being imaged and viewing distance. The commenter stated that an example of a “simple” scene would be a scene of 20–25 components viewed from a distance of 15–25 feet. The commenter stated that this approach offers a high probability of leak detection by a technician and limiting the number of components to 25 in a simple scene means a technician is likely to have great discernment or granularity of the image which improves the ability to detect a leak.

Response: The EPA considers dwell time an important component of an OGI monitoring protocol. It is important to specify the minimum amount of time that OGI camera operators must survey a scene in order to reliably assess whether leaks are present. Surveying a scene too quickly can lead to OGI camera operators not identifying leaks, potentially leading to an increase in fugitive emissions over time by leaving the leaks unaddressed. The EPA therefore disagrees with the comment suggesting removal of the dwell time requirement.

To be clear on our intent, in the final rule, the EPA has clarified that the dwell time requirements in appendix K represent the minimum amount of time required to survey a scene in order to

provide adequate probability of leak detection, and that dwell time begins only after the OGI camera operator has put the camera in an appropriate operating mode and the scene is in focus and steady. If the OGI camera operating mode must be changed, the dwell time restarts. We have further clarified that additional dwell time beyond the minimum requirement may be necessary to adequately monitor for leaks, depending on conditions and configuration of the components. OGI camera operators should use training and knowledge of conditions to adjust dwell time when needed.

However, the EPA agrees with commenters that allowing for a standard dwell time instead of requiring the dwell time to be based on the number of components is appropriate in some instances. In the final rule, the EPA is removing table 14–1 in the proposed appendix K, which was a mechanism intended to allow a reduction in dwell time by reducing the number of components being visualized at one time. Instead, the EPA is finalizing a standard dwell time requirement for “simple” scenes. To implement this change, we have created a definition for a simple scene in appendix K, where a simple scene is defined as a scene consisting of 10 or fewer components. For a simple scene, the OGI camera operator must dwell for a minimum of 10 seconds per angle. The EPA disagrees that a standard dwell time should be extended to scenes that do not qualify as a simple scene (*i.e.*, a scene with greater than 10 components) because these scenes are often very complex with complicated backgrounds and an increased density of components. These factors make it more difficult for OGI camera operators to visualize the individual components in the scene, and an OGI camera operator needs to spend more time looking at the individual components to ensure there are no leaks. For these scenes, the EPA is retaining the requirement, as proposed, that the OGI camera operator must dwell on the scene for a minimum of 2 seconds per component in the field of view. As we noted in the December 2022 Supplemental Proposal,⁷⁶¹ 2 seconds per component in the field of view aligns closely with the estimated time to complete a monitoring survey based on data provided by OGI camera operators and provides adequate time to determine whether a leak is present. Although commenters suggested different timeframes for a minimum dwell time, the commenters did not provide substantive information on why

these different minimum dwell times would ensure that an OGI camera operator views a scene long enough to find all leaks that exist. The EPA notes that OGI camera operators can choose to reduce the dwell time of these more complex scenes by reducing the viewing distance from components, thereby reducing the number of components in the field of view and changing the more complex scene into a simple scene. This would allow the OGI camera operator to use the standard dwell time for simple scenes.

2. Detection Limits

Comment: One commenter⁷⁶² agreed with the new minimum detection level of butane as 5 grams per hour (g/hr) but questioned the level of detection for propane. The commenter stated that the foundation of appendix K and OGI as a technology is based on the response factors, per section 6.1.1 and Annex 1 of appendix K. Therefore, the commenter states that propane (a compound with a response factor of 1.000) should not have a detection threshold higher than methane (a compound with a response factor of 0.297). The commenter recommended that propane have a minimum detection level similar to butane, 5 g/hr, since it is also over 3.3 times more absorptive for the defined technology in the spectral range of the technology, and the commenter suggested that all references to the minimum detection threshold of propane in section 8 also be changed to 5 g/hr. Another commenter⁷⁶³ questioned why a lower mass rate criteria was selected for butane when the response factor for butane and propane are almost identical. The commenter stated that this seems inconsistent with the language in section 1.2, which allows for the average response factor approach with respect to propane.

Response: The EPA reviewed the detection limit criteria included in the December 2022 Supplemental Proposal in light of the comments and updated the TSD for appendix K. As noted in the updated TSD that accompanies the final appendix K, the expected field detection limit of propane is 22 g/hr. Based on this detection limit and updated response factors⁷⁶⁴ for methane and n-butane, we have determined that the field detection limits of methane and n-butane are 19 g/hr and 29 g/hr, respectively. It may seem

⁷⁵⁵ EPA–HQ–OAR–2021–0317–2177, –2258, –2421, –2428, and –2196.

⁷⁵⁶ EPA–HQ–OAR–2021–0317–2483.

⁷⁵⁷ EPA–HQ–OAR–2021–0317–2366 and –2483.

⁷⁵⁸ EPA–HQ–OAR–2021–0317–2305.

⁷⁵⁹ EPA–HQ–OAR–2021–0317–2421.

⁷⁶⁰ EPA–HQ–OAR–2021–0317–2428.

⁷⁶¹ 87 FR 74839 (December 6, 2022).

⁷⁶² EPA–HQ–OAR–2021–0317–2421.

⁷⁶³ EPA–HQ–OAR–2021–0317–2428.

⁷⁶⁴ See August 18, 2023, email from Yousheng Zeng to Gerri Garwood, included in the docket for this action.

counterintuitive that propane has a greater detection limit than methane, even though propane has a higher response factor. This is due to the difference in the molecular weights of the compounds. Molecular weight is used to convert between the concentration (ppmv) and mass flowrate (g/hr). Because propane is nearly three times as heavy as methane, the detection limit for propane, when expressed as a mass flowrate, is higher than the detection limit for methane. Similarly, butane is heavier than propane, so the detection limit expressed as a mass flowrate is higher for butane than for propane.⁷⁶⁵

While we note that the laboratory detection limits will be lower than this, as demonstrated in the supporting documentation provided in the OGI detection estimation memo⁷⁶⁶ included in the docket, because the detection limits in appendix K are used to set the operating envelope, it is important that they are achievable in the field, not just the laboratory. We have updated the final appendix K TSD and final text within appendix K to reflect these updated detection limits. We have also updated the final appendix K TSD to discuss the derivation of the field detection limits for compounds other than propane.

3. Operating Envelopes

Comment: One commenter⁷⁶⁷ stated the operating envelope is overly complicated and that daily field checks ensure the camera operator can identify fugitive emissions and set a maximum viewing distance. The commenter suggested that a change in weather that could significantly alter the viewing distance could trigger a retest to ensure the viewing distance set point is still adequate to identify fugitive emissions. Another commenter⁷⁶⁸ maintained that most OGI camera manufacturers plan to have completed the development of the operating envelopes after appendix K is promulgated but urged that a daily or site-specific distance check should remain an option. The commenter acknowledged that there may be times when OGI camera operators will be using an OGI camera that does not yet have any established operating envelopes either because the camera manufacturer has yet to publish operating envelopes once appendix K is promulgated, the OGI camera is new to market, or monitoring conditions for a

specific survey or site are unique regarding the pre-defined operating envelopes and the camera operator may want to ensure that the delta-T and viewing distance are appropriately set.

Response: The EPA agrees that there may be times when an OGI camera model does not yet have an established operating envelope, such as immediately after development of the OGI camera, or when an OGI camera operator may need to adjust an operating envelope to account for site-specific conditions, such as wind speed. In the final appendix K, the EPA has added an option to conduct a daily field check for distance in lieu of using a pre-defined operating envelope. The EPA notes that this is an optional field check for distance when an OGI camera operator is not using a pre-defined operating envelope. For OGI camera operators using a pre-defined operating envelope, this daily distance check is not required.

If an OGI camera operator chooses to use this optional daily field check for distance, it must be documented. The daily field check must use the same gases at the same flow rate as those specified in section 6.1.2 for the initial verification check and development of the operating envelopes. The daily field check must be conducted by the OGI camera operator(s) who will be conducting the monitoring survey using the OGI camera(s) that will be used to conduct the monitoring survey. If the OGI camera operator encounters delta-T values that are lower than or wind speed values that are higher than the values during the daily field check, the distance check must be repeated.

4. Other Changes

Additionally, the EPA has made a number of clarifications and minor adjustments to the text of appendix K in response to comments received:

- Added definitions for OGI camera operator, simple scene, and survey hour.
- Adjusted the specifications for instrumentation described in section 6.2 that is used for the initial verification of the camera specifications.
- Added specifications for coordinates when global positioning systems are used to document the path taken by the OGI camera operator.
- Removed the language that allows for full video records in lieu of video clips or photographs. We are clarifying that a full video record does suffice for video clips of leaks, but the addition of the language in the supplemental proposal caused unintended confusion to commenters.

- Reduced the audit frequency for OGI camera operators from quarterly to semiannually.

- In Annex 1, changed the pixel count for each area from a minimum of 1 to 0.5 percent of the total pixels of the detector.

- In Annex 1, changed the minimum number of measured infrared radiance pixel area within a data set to 1000 data points.

XV. Prevention of Significant Deterioration and Title V Permitting

This final rule regulates GHGs (in the form of methane limitations) under CAA section 111. Because regulation of GHGs under CAA section 111 could have implications for other EPA rules and for permits written under the CAA PSD preconstruction permit program and the CAA title V operating permit program, the EPA is including provisions in this final rule that explicitly address some of these potential implications, consistent with our experience in prior rules regulating GHGs. The EPA included and explained the basis for similar provisions when promulgating 2016 NSPS OOOOa, as well as the 2015 subpart TTTT NSPS for electric utility generating units. See 81 FR 35823, 35871 (June 3, 2016) and 80 FR 64509, 64628 (October 23, 2015). The discussion in these prior rule preambles equally applies to the oil and gas sources subject to NSPS OOOOb and EG OOOOc.

In summary, in light of the U.S. Supreme Court's decision in *Utility Air Regulatory Group v. Environmental Protection Agency*, 573 U.S. 302 (2014) (*UARG*), the EPA may not treat GHGs as an air pollutant for purposes of determining whether a source is a major source (or modification thereof) for the purpose of PSD applicability. Certain portions of the EPA's PSD regulations (specifically, the definition of "subject to regulation") effectively ensure that most sources will not trigger PSD solely by virtue of their GHG emissions. *E.g.*, 40 CFR 51.166(b)(48)(iv), 52.21(b)(49)(iv). However, the EPA's PSD regulations (specifically, the definition of "regulated NSR pollutant") provide additional bases for PSD applicability for pollutants that are regulated under CAA section 111. To address this latter component of PSD applicability, the EPA is adding provisions within the subpart OOOOb NSPS and subpart OOOOc EG to help clarify that the promulgation of GHG standards under section 111 will not result in additional sources becoming subject to PSD based solely on GHG emissions, which would be contrary to the holding in *UARG*. See 40 CFR

⁷⁶⁵ See TSD, Optical Gas Imaging Protocol (40 CFR part 60, Appendix K), September 2023. Pages 124–125.

⁷⁶⁶ EPA–HQ–OAR–2021–0317–1532.

⁷⁶⁷ EPA–HQ–OAR–2021–0317–2305.

⁷⁶⁸ EPA–HQ–OAR–2021–0317–2428.

60.5360b(b)(1)–(2), 60.5361c(b)(1)–(2). These provisions are similar to those in the 2016 NSPS OOOOa and other section 111 rules that regulate GHGs. See, e.g., 40 CFR 60.5360a(b)(1)–(2), 60.5515(b)(1)–(2).

The EPA understands there are also concerns that if methane were to be subject to regulation as a separate air pollutant from GHGs, sources that emit methane above the PSD thresholds or modifications that increase methane emissions could be subject to the PSD program. To address this concern and for purposes of clarity, the EPA is adopting regulatory text within subpart OOOOb NSPS and subpart OOOOc EG to clarify that the air pollutant that is subject to regulation is GHGs, even though the standard is expressed in the form of a limitation on emissions of methane. See 40 CFR 60.5360b(a), 60.5361c(a). This language is substantially similar to language found in, for example, the 2016 NSPS OOOOa and other rules. See, e.g., 40 CFR 60.5360a(a), 60.5515(a).

For sources that are subject to the PSD program based on non-GHG emissions, the CAA continues to require that PSD permits satisfy the best available control technology (BACT) requirement for GHGs. Based on the language in the PSD regulations, the EPA and states may continue to limit the application of BACT to GHG emissions in those circumstances where a new source emits GHGs in the amount of at least 75,000 tpy on a CO₂ Eq. basis or an existing major source increases emissions of GHGs by more than 75,000 tpy on a CO₂ Eq. basis. See 40 CFR 51.166(b)(48)(iv), 52.21(b)(49)(iv). The revisions to the regulatory text within subparts OOOOb NSPS and OOOOc EG ensure that this BACT applicability level remains operable to sources of GHGs regulated under CAA section 111, as have similar revisions in prior rules. See 40 CFR 60.5360b(b)(1)–(2), 60.5361c(b)(1)–(2); see also, e.g., 40 CFR 60.5360a(b)(1)–(2), 60.5515(b)(1)–(2). This rule does not require any additional revisions to SIPs.

Regarding title V, the *UARG* decision similarly held that the EPA may not treat GHGs as an air pollutant for purposes of determining whether a source is a major source for the purpose of title V applicability. Promulgation of CAA section 111 requirements for GHGs will not result in the EPA imposing a requirement that stationary sources obtain a title V permit solely because such sources emit or have the potential

to emit GHGs above the applicable major source thresholds.⁷⁶⁹

To be clear, however, unless exempted by the Administrator through regulation under CAA section 502(a), any source, including a “non-major source,” subject to a standard or regulation under CAA section 111 is required to apply for, and operate pursuant to, a title V permit that ensures compliance with all applicable CAA requirements for the source, including any GHG-related applicable requirements. This aspect of the title V program is not affected by *UARG*.⁷⁷⁰ The EPA is including an exemption from the obligation to obtain a title V permit for sources subject to NSPS OOOOb and EG OOOOc, unless such sources would otherwise be required to obtain a permit under 40 CFR 70.3(a) or 40 CFR 71.3(a), as the EPA did in NSPS OOOO and OOOOa.⁷⁷¹ See 40 CFR 60.5360b(c); see also 40 CFR 60.5370, 60.5370a. However, sources that are subject to the CAA section 111 standards promulgated in this rule and that are otherwise required to obtain a title V permit under 40 CFR 70.3(a) or 40 CFR 71.3(a) will be required to apply for, and operate pursuant to, a title V permit that ensures compliance with all applicable CAA requirements, including any GHG-related applicable requirements.

XVI. Summary of Cost, Environmental, and Economic Impacts

A. What are the air quality impacts?

The EPA projected that, from 2024 to 2038, relative to the baseline, the final NSPS OOOOb and EG OOOOc will reduce about 58 million short tons of

⁷⁶⁹ The additional regulatory text in the final rule further ensures that title V regulations are not applied to GHGs solely because they are regulated under CAA section 111. See 40 CFR 60.5360b(b)(3)–(4), 60.5361c(b)(3)–(4); see also, e.g., 40 CFR 60.5360a(b)(3)–(4), 60.5515(b)(3)–(4). The EPA understands that concerns regarding the regulation of methane as a separate air pollutant (described with respect to PSD) also apply to title V. The EPA’s regulatory text here in this final rule—clarifying that the pollutant subject to regulation is GHGs—similarly addresses these concerns with respect to title V. See 40 CFR 60.5360b(a), 60.5361c(a).

⁷⁷⁰ See Memorandum from Janet G. McCabe, Acting Assistant Administrator, Office of Air and Radiation, and Cynthia Giles, Assistant Administrator, Office of Enforcement and Compliance Assurance, to Regional Administrators, Regions 1–10, *Next Steps and Preliminary Views on the Application of Clean Air Act Permitting Programs to Greenhouse Gases Following the Supreme Court’s Decision in Utility Regulatory Group v. Environmental Protection Agency* (July 24, 2014) at 5.

⁷⁷¹ The EPA provided the rationale for exempting this source category from the title V permitting requirements during the rulemaking for the 2012 NSPS OOOO. See 76 FR 52737, 52751 (August 23, 2011). That rationale continues to apply to this source category.

methane emissions (1.5 billion tons CO₂ Eq. using a GWP of 28), 16 million short tons of VOC emissions, and 590 thousand short tons of HAP emissions from affected facilities. The EPA projected regulatory impacts beginning in 2024 as that year represents the first full year of implementation of the final NSPS OOOOb. The EPA assumes that emissions impacts of the final EG OOOOc will begin in 2028. The EPA projected impacts through 2038 to illustrate the accumulating effects of this rule over a longer period. The EPA did not estimate impacts after 2038 for reasons including limited information, as explained in the RIA.

B. What are the secondary impacts?

The energy impacts described in this section of this document are those energy requirements associated with the operation of emissions control devices. Potential impacts on the national energy economy from the rule are discussed under economic impacts in section XVI.D of this document. There will likely be minimal change in emissions control energy requirements resulting from this rule. Additionally, this final action continues to encourage the use of emissions controls that recover hydrocarbon products that can be used onsite as fuel or reprocessed within the production process for sale.

C. What are the cost impacts?

The EAV of the regulatory compliance cost associated with the final NSPS OOOOb and EG OOOOc over the 2024 to 2038 period was estimated to be \$1.5 billion per year using a 2-percent discount rate (in 2019 dollars), \$1.5 billion per year using a 3-percent discount rate, and \$1.6 billion using a 7-percent discount rate. The corresponding estimates of the PV of compliance costs were \$19 billion using a 2-percent discount rate, \$18 billion using a 3-percent discount rate, and \$14 billion using a 7-percent discount rate.

These estimates include the producer revenues associated with the projected increase in the recovery of saleable natural gas, using the 2022 Annual Energy Outlook (AEO) projection of natural gas prices to estimate the value of the change in the recovered gas at the wellhead projected to result from the final action. Estimates of the value of the recovered product have been included in previous regulatory analyses as offsetting compliance costs and are appropriate to include when assessing the societal cost of a regulation. If the recovery of saleable natural gas is not accounted for, the EAV of the regulatory compliance costs of the final rule over the 2024 to 2038

period were estimated to be \$2.4 billion using a 2-percent discount rate, \$2.4 billion using a 3-percent discount rate, and \$2.4 billion per year using a 7-percent discount rate. The PV of these costs were estimated to be \$31 billion using a 2-percent discount rate, \$29 billion using a 3-percent discount rate, and \$22 billion using a 7-percent discount rate.

D. What are the economic impacts?

The EPA conducted a suite of economic impact and distributional analyses for this rule, as detailed in section 4 of the final RIA. To provide a partial measure of the economic consequences of the final NSPS OOOOb and EG OOOOc, the EPA developed a pair of single-market, static partial-equilibrium analyses of national crude oil and natural gas markets. We implemented the pair of single-market analyses instead of a coupled market or general equilibrium approach to provide broad insights into potential national-level market impacts while providing maximum analytical transparency. We estimated the price and quantity impacts of the final NSPS OOOOb and EG OOOOc on crude oil and natural gas markets for a subset of years within the time horizon analyzed in the RIA. The models are parameterized using production and price data from the EIA and supply and demand elasticity estimates from the economics literature.

For oil well sites, the RIA projects that regulatory costs are at their highest in 2038, the final year analyzed in the RIA. We estimated that the final rule could result in a maximum decrease in annual crude oil production of about 41.1 million barrels in 2038 (or about 1.05 percent of baseline projections of onshore crude oil production) with a maximum price increase of \$0.25 per barrel (or about 0.33 percent of the projected baseline price).

For natural gas-related sites, the RIA projects that regulatory costs are at their highest in 2028. We estimated that the final rule could result in a maximum decrease in natural gas production of about 272.5 million Mcf in 2028 (or about 0.75 percent of baseline projections of onshore natural gas production) with a maximum price increase of \$0.06 per Mcf (or about 1.76 percent of the projected baseline natural gas price).

Before 2028, the modeled market impacts are smaller than later impacts as only the incremental requirements under the final NSPS OOOOb are assumed to be in effect. Please see section 4.1 of the RIA for more detail on the formulation and implementation of the model as well as a discussion of

several important caveats and limitations associated with the approach.

As discussed in the RIA for this final rule, employment impacts of environmental regulations are generally composed of a mix of potential declines and gains in different areas of the economy over time. Regulatory employment impacts can vary across occupations, regions, and industries; by labor and product demand and supply elasticities; and in response to other labor market conditions. Isolating such impacts is a challenge, as they are difficult to disentangle from employment impacts caused by a wide variety of ongoing, concurrent economic changes.

The oil and natural gas industry directly employs approximately 140,000 people in oil and natural gas extraction, a figure which varies with market prices and technological change. A large number of workers are also employed in related sectors that provide materials and services for the industry.⁷⁷² As indicated above, the final NSPS OOOOb and EG OOOOc are projected to cause small changes in oil and natural gas production and prices. As a result, demand for labor employed in oil and natural gas-related activities and associated industries might experience adjustments as there may be increases in compliance-related labor requirements as well as changes in employment due to quantity effects in directly regulated sectors and sectors that consume oil and natural gas products.

E. What are the benefits?

To satisfy the requirement of E.O. 12866 and to inform the public, the EPA estimated the climate and health benefits due to the emissions reductions projected under the final NSPS OOOOb and EG OOOOc. The EPA expects climate and health benefits due to the emissions reductions projected under the final NSPS OOOOb and EG OOOOc. The EPA estimated the climate benefits of methane emission reductions expected from this final rule using SC-CH₄ estimates that reflect recent advances in the scientific literature on climate change and its economic impacts and incorporate recommendations made by the National Academies of Science, Engineering, and Medicine (National Academies 2017). The EPA presented these estimates in a sensitivity analysis in the December 2022 RIA, solicited public comment on the methodology and use of these

estimates, and has conducted an external peer review of these estimates, as described further below.

The SC-CH₄ is the monetary value of the net harm to society from emitting a metric ton of CH₄ into the atmosphere in a given year, or the benefit of avoiding that increase. In principle, SC-CH₄ is a comprehensive metric that includes the value of all climate change impacts (both negative and positive), including (but not limited to) changes in net agricultural productivity, human health effects, property damage from increased flood risk, changes in the frequency and severity of natural disasters, disruption of energy systems, risk of conflict, environmental migration, and the value of ecosystem services. The SC-CH₄ therefore, reflects the societal value of reducing emissions of the gas in question by one metric ton and is the theoretically appropriate value to use in conducting benefit-cost analyses of policies that affect methane emissions. In practice, data and modeling limitations restrain the ability of SC-CH₄ estimates to include all physical, ecological, and economic impacts of climate change, implicitly assigning a value of zero to the omitted climate damages. The estimates are, therefore, a partial accounting of climate change impacts and likely underestimate the marginal benefits of abatement.

Since 2008, the EPA has used estimates of the social cost of various greenhouse gases (*i.e.*, social cost of carbon dioxide (SC-CO₂), SC-CH₄, and social cost of nitrous oxide (SC-N₂O)), collectively referred to as the “social cost of greenhouse gases” (SC-GHG), in analyses of actions that affect GHG emissions. The values used by the EPA from 2009 through 2016, and since 2021—including in the November 2021 RIA and December 2022 RIA for this rulemaking—have been consistent with those developed and recommended by the Interagency Working Group on the SC-GHG (IWG); and the values used from 2017 through 2020 were consistent with those required by Executive Order (E.O.) 13783. During that time, the National Academies conducted a comprehensive review of the SC-CO₂ and issued a final report in 2017 recommending specific criteria for future updates to the SC-CO₂ estimates, a modeling framework to satisfy the specified criteria, and both near-term updates and longer-term research needs pertaining to various components of the estimation process. The IWG was reconstituted in 2021 and E.O. 13990 directed it to develop a comprehensive update of its SC-GHG estimates, recommendations regarding areas of

⁷⁷² Employment figure drawn from the Bureau of Labor Statistics Current Employment Statistics for NAICS code 211.

decision-making to which SC–GHG should be applied, and a standardized review and updating process to ensure that the recommended estimates continue to be based on the best available economics and science going forward.

The EPA is a member of the IWG and is participating in the IWG's work under E.O. 13990. While that process continues, as noted in previous EPA RIAs, the EPA is continuously reviewing developments in the scientific literature on the SC–GHG, including more robust methodologies for estimating damages from emissions, and looking for opportunities to further improve SC–GHG estimation going forward. In the RIA for the December 2022 Supplemental Proposal, the EPA included a sensitivity analysis of the climate benefits of the supplemental proposal using a new set of SC–GHG estimates that incorporates recent research addressing recommendations of the National Academies of Science, Engineering, and Medicine (2017), in addition to using the IWG recommended interim SC–GHG estimates presented in the *Technical Support Document: Social Cost of Carbon, Methane, and Nitrous Oxide Interim Estimates under Executive Order 13990*, published in February 2021 (IWG, 2021).

The EPA solicited public comment on the sensitivity analysis and the accompanying draft technical report, which explains the methodology underlying the new set of estimates, in the December 2022 Supplemental Proposal.⁷⁷³ To ensure that the methodological updates adopted in the technical report are consistent with economic theory and reflect the latest science, the EPA also initiated an external peer review panel to conduct a high-quality review of the technical report, completed in May 2023. The peer reviewers commended the agency on its development of this update, calling it a much-needed improvement in estimating the SC–GHG and a significant step towards addressing the National Academies' recommendations with defensible modeling choices based on current science. The peer reviewers provided numerous recommendations for refining the presentation and for future modeling improvements, especially with respect to climate change impacts and associated damages that are not currently included in the analysis. Additional discussion of omitted impacts and other updates have been incorporated into the technical

report to address peer reviewer recommendations. Complete information about the external peer review, including the peer reviewer selection process, the final report with individual recommendations from peer reviewers, and the EPA's response to each recommendation is available on the EPA's website. The EPA is a member of the Interagency Working Group (IWG) on the SC–GHG and continues to participate in its work. The EPA's new SC–GHG estimates along with the peer review of the updated methodology will be among the many technical inputs available to the IWG as it continues its work.

An overview of the methodological updates incorporated into the new SC–GHG estimates is provided in the RIA. A more detailed explanation of each input and the modeling process is provided in the technical report, *EPA Report on the Social Cost of Greenhouse Gases: Estimates Incorporating Recent Scientific Advances* (EPA 2023), which is also included as supporting material for the RIA in the docket.⁷⁷⁴ However, we emphasize that the monetized benefits analysis is entirely distinct from the statutory BSER determinations proposed herein and is presented solely for the purposes of complying with E.O. 12866. As discussed in more detail in the November 2021 Proposal, the December 2022 Supplemental Proposal, and earlier in this action, the EPA weighed the relevant statutory factors to determine the appropriate standards and did not rely on the monetized benefits analysis for purposes of determining the standards. E.O. 12866 separately requires the EPA to perform a benefit-cost analysis, including monetizing costs and benefits where practicable, and the EPA has conducted such an analysis. The monetized climate benefits calculated using the SC–CH₄ are included in the benefit-cost analysis, and thus, as is generally the case with any analytical methods, data, or results associated with RIAs, the EPA welcomes the opportunity to continually improve its understanding through public input on these estimates.

The EPA estimated the PV of the climate benefits over the 2024 to 2038 period to be \$110 billion at a 2 percent near-term Ramsey discount rate. The EAV of these benefits is estimated to be \$8.5 billion per year at the 2 percent near-term Ramsey discount rate. These values represent only a partial accounting of climate impacts from methane emissions and do not account

for health effects of ozone exposure from the increase in methane emissions.

Under the final NSPS OOOOb and EG OOOOc, the EPA expects that the projected VOC emissions reductions will improve air quality and improve health and welfare associated with exposure to ozone, PM_{2.5}, and HAP. In the national-level analysis of public health impacts, the EPA used the environmental Benefits Mapping and Analysis Program—Community Edition (BenMAP–CE) software program to quantify counts of premature deaths and illnesses attributable to photochemical modeled changes in summer season average ozone concentrations resulting from VOC emissions changes. The methods for quantifying the number and value of air pollution-attributable premature deaths and illnesses are described in the TSD titled *Estimating PM_{2.5}- and Ozone-Attributable Health Benefits*⁷⁷⁵. The reductions in health-harming pollution would result in significant public health benefits including avoided premature deaths, reductions in new asthma cases and incidences of asthma symptoms, reductions in hospital admissions and emergency department visits, and reductions in lost school days. These health benefits are also monetized and the EPA estimated the PV of the ozone health benefits over the 2024 to 2038 period to be \$7.0 billion at a 2 percent discount rate, \$6.1 billion at a 3 percent discount rate, and \$3.5 billion at a 7 percent discount rate. The EAV of these benefits is estimated to be \$540 million at a 2 percent discount rate, \$510 million at a 3 percent discount rate, and \$380 million at a 7 percent discount rate.

These values represent only a partial accounting of the potential benefits of this final rule. Several categories of climate, human health, and welfare benefits from methane, VOC, and HAP emissions reductions remain unmonetized and are thus not directly reflected in the quantified benefit estimates. The RIA presents a series of qualitative discussions of these unquantified and unmonetized benefits.

F. What analyses of environmental justice did we conduct?

As discussed earlier in this preamble and in the November 2021 proposal, the EPA engaged extensively with representatives of communities with environmental justice concerns to inform this rulemaking, and heard directly from environmental justice

⁷⁷³ See volume 2 of the RTC, chapter 20, in EPA–HQ–OAR–2021–0317.

⁷⁷⁴ For more information about the development of these estimates, see www.epa.gov/environmental-economics/scghg.

⁷⁷⁵ https://www.epa.gov/system/files/documents/2023-01/Estimating%20PM2.5-%20and%20Ozone-Attributable%20Health%20Benefits%20TSD_0.pdf.

organizations and community representatives during the public hearings and as part of the public comment process for both the November 2021 Proposal and December 2022 Supplemental Proposal. Our engagement with these stakeholders surfaced several concerns regarding the health effects of air pollution associated with oil and gas facilities, the implications of climate change and associated extreme weather events for health and well-being in overburdened and vulnerable communities, and accessibility to data and information regarding sources near environmental justice communities. These stakeholders also highlighted the importance of reducing emissions of methane and other health-harming air pollutants from specific sources subject to this rule, such as from malfunctioning control devices and flaring of associated gas, super-emitter events, fugitive emissions from well sites, compressor stations, and storage vessels.

The EPA gave these comments careful consideration as part of the overall record for this rulemaking. Consistent with applicable executive orders and EPA policy, the Agency has also carefully analyzed the environmental justice implications of the climate-related benefits that will result from this rule, as well as the benefits associated with reductions in emissions of ozone precursors (namely VOCs) and hazardous air pollutants. The EPA believes that *the suite of regulatory protections established in this rule, and the resulting reductions in harmful air pollution from new and existing oil and gas sources, will have a range of significant benefits for communities with environmental justice concerns.*

Among other things, this rule will lead to significant reductions in methane pollution amounting to approximately 1.5 billion tons CO₂-e through 2038, yielding climate-related benefits valued at \$110 billion. Because climate change is already having disproportionate and adverse impacts on communities with environmental justice concerns, these methane reductions and their associated climate-related benefits are of particular importance for these communities.

Along with these climate-related benefits, this final rule is also anticipated to achieve significant VOC reductions of 16 million tons and HAP reductions of 590 thousand tons. Many of these reductions come from applying available control measures to sources that environmental justice organizations and communities have identified as being frequently located near overburdened and vulnerable

populations, and as posing important air quality and health concerns for communities. By ensuring that these sources are subject to nationally applicable requirements that reflect highly effective technologies and approaches for limiting and reducing emissions, the EPA believes that the NSPS and EG being finalized here will provide a high and consistent degree of protection against the full suite of harmful air pollutants associated with oil and gas sources, including in communities with environmental justice concerns that are located near these sources and exposed to these emissions.

1. Environmental Justice and the Impacts of Climate Change

In 2009, under the *Endangerment and Cause or Contribute Findings for Greenhouse Gases Under Section 202(a) of the Clean Air Act* (“Endangerment Finding,” 74 FR 66496), the Administrator considered how climate change threatens the health and welfare of the U.S. population.⁷⁷⁶ As part of that consideration, she also considered risks to minority and low-income individuals and communities, finding that certain parts of the U.S. population may be especially vulnerable based on their characteristics or circumstances. These groups include economically and socially disadvantaged communities, including those that have been historically marginalized or overburdened; individuals at vulnerable lifestages, such as the elderly, the very young, and pregnant or nursing women; those already in poor health or with comorbidities; the disabled; those experiencing homelessness, mental illness, or substance abuse; and/or Indigenous or minority populations dependent on one or limited resources for subsistence due to factors including but not limited to geography, access, and mobility.

Scientific assessment reports produced over the past decade by the

USGCRP,^{777 778} the IPCC,^{779 780 781 782} the National Academies of Science, Engineering, and Medicine,^{783 784} and

⁷⁷⁷ USGCRP, 2018: *Impacts, Risks, and Adaptation in the United States: Fourth National Climate Assessment, Volume II* [Reidmiller, D.R., C.W. Avery, D.R. Easterling, K.E. Kunkel, K.L.M. Lewis, T.K. Maycock, and B.C. Stewart (eds.)]. U.S. Global Change Research Program, Washington, DC, USA, 1515 pp. doi:10.7930/NCA4.2018.

⁷⁷⁸ USGCRP, 2016: *The Impacts of Climate Change on Human Health in the United States: A Scientific Assessment*. Crimmins, A., J. Balbus, J.L. Gamble, C.B. Beard, J.E. Bell, D. Dodgen, R.J. Eisen, N. Fann, M.D. Hawkins, S.C. Herring, L. Jantarasami, D.M. Mills, S. Saha, M.C. Sarofim, J. Trtanj, and L. Ziska, Eds. U.S. Global Change Research Program, Washington, DC, 312 pp. <https://dx.doi.org/10.7930/JOR49NQX>.

⁷⁷⁹ Oppenheimer, M., M. Campos, R. Warren, J. Birkmann, G. Luber, B. O'Neill, and K. Takahashi, 2014: *Emergent risks and key vulnerabilities*. In: *Climate Change 2014: Impacts, Adaptation, and Vulnerability. Part A: Global and Sectoral Aspects. Contribution of Working Group II to the Fifth Assessment Report of the Intergovernmental Panel on Climate Change* [Field, C.B., V.R. Barros, D.J. Dokken, K.J. Mach, M.D. Mastrandrea, T.E. Bilir, M. Chatterjee, K.L. Ebi, Y.O. Estrada, R.C. Genova, B. Girma, E.S. Kissel, A.N. Levy, S. MacCracken, P.R. Mastrandrea, and L.L. White (eds.)]. Cambridge University Press, Cambridge, United Kingdom and New York, NY, USA, pp. 1039–1099.

⁷⁸⁰ Porter, J.R., L. Xie, A.J. Challinor, K. Cochrane, S.M. Howden, M.M. Iqbal, D.B. Lobell, and M.I. Travasso, 2014: *Food security and food production systems*. In: *Climate Change 2014: Impacts, Adaptation, and Vulnerability. Part A: Global and Sectoral Aspects. Contribution of Working Group II to the Fifth Assessment Report of the Intergovernmental Panel on Climate Change* [Field, C.B., V.R. Barros, D.J. Dokken, K.J. Mach, M.D. Mastrandrea, T.E. Bilir, M. Chatterjee, K.L. Ebi, Y.O. Estrada, R.C. Genova, B. Girma, E.S. Kissel, A.N. Levy, S. MacCracken, P.R. Mastrandrea, and L.L. White (eds.)]. Cambridge University Press, Cambridge, United Kingdom and New York, NY, USA, pp. 485–533.

⁷⁸¹ Smith, K.R., A. Woodward, D. Campbell-Lendrum, D.D. Chadee, Y. Honda, Q. Liu, J.M. Olwoch, B. Revich, and R. Sauerborn, 2014: *Human health: impacts, adaptation, and co-benefits*. In: *Climate Change 2014: Impacts, Adaptation, and Vulnerability. Part A: Global and Sectoral Aspects. Contribution of Working Group II to the Fifth Assessment Report of the Intergovernmental Panel on Climate Change* [Field, C.B., V.R. Barros, D.J. Dokken, K.J. Mach, M.D. Mastrandrea, T.E. Bilir, M. Chatterjee, K.L. Ebi, Y.O. Estrada, R.C. Genova, B. Girma, E.S. Kissel, A.N. Levy, S. MacCracken, P.R. Mastrandrea, and L.L. White (eds.)]. Cambridge University Press, Cambridge, United Kingdom and New York, NY, USA, pp. 709–754.

⁷⁸² IPCC, 2018: *Global Warming of 1.5 °C*. An IPCC Special Report on the impacts of global warming of 1.5 °C above pre-industrial levels and related global greenhouse gas emission pathways, in the context of strengthening the global response to the threat of climate change, sustainable development, and efforts to eradicate poverty [Masson-Delmotte, V., P. Zhai, H.-O. Pörtner, D. Roberts, J. Skea, P.R. Shukla, A. Pirani, W. Moufouma-Okia, C. Péan, R. Pidcock, S. Connors, J.B.R. Matthews, Y. Chen, X. Zhou, M.I. Gomis, E. Lonnoy, T. Maycock, M. Tignor, and T. Waterfield (eds.)]. In Press.

⁷⁸³ National Research Council. 2011. *America's Climate Choices*. Washington, DC: The National Academies Press. <https://doi.org/10.17226/12781>.

⁷⁸⁴ National Academies of Sciences, Engineering, and Medicine. 2017. *Communities in Action: Pathways to Health Equity*. Washington, DC: The National Academies Press. <https://doi.org/10.17226/24624>.

⁷⁷⁶ Earlier studies and reports can be found at <https://www.epa.gov/cira/social-vulnerability-report>.

the EPA⁷⁸⁵ add more evidence that the impacts of climate change raise potential EJ concerns. These reports conclude that less-affluent, traditionally marginalized and predominantly non-White communities can be especially vulnerable to climate change impacts because they tend to have limited resources for adaptation, are more dependent on climate-sensitive resources such as local water and food supplies or have less access to social and information resources. Some communities of color, specifically populations defined jointly by ethnic/racial characteristics and geographic location (e.g., African-American, Black, and Hispanic/Latino communities; Native Americans, particularly those living on Tribal lands and Alaska Natives), may be uniquely vulnerable to climate change health impacts in the U.S., as discussed below. In particular, the 2016 scientific assessment on the *Impacts of Climate Change on Human Health*⁷⁸⁶ found with high confidence that vulnerabilities are place- and time-specific, lifestages and ages are linked to immediate and future health impacts, and social determinants of health are linked to greater extent and severity of climate change-related health impacts.

Per the NCA4, “Climate change affects human health by altering exposures to heat waves, floods, droughts, and other extreme events; vector-, food- and waterborne infectious diseases; changes in the quality and safety of air, food, and water; and stresses to mental health and well-being.”⁷⁸⁷ Many health conditions such as cardiopulmonary or respiratory illness and other health impacts are associated with and exacerbated by an increase in GHGs and climate change outcomes, which is problematic as these diseases occur at higher rates within vulnerable communities. Importantly, negative public health outcomes include those that are physical in nature, as well as mental, emotional, social, and economic.

The scientific assessment literature, including the previously referenced reports, demonstrates that there are

myriad ways in which these populations may be affected at the individual and community levels. Outdoor workers, such as construction or utility workers and agricultural laborers, who are frequently part of already at-risk groups, are exposed to poor air quality and extreme temperatures without relief. Furthermore, individuals within EJ populations of concern face greater housing and clean water insecurity and bear disproportionate economic impacts and health burdens associated with climate change effects. They also have less or limited access to healthcare and affordable, adequate health or homeowner insurance. The urban heat island effect can add additional stress to vulnerable populations in densely populated cities who do not have access to air conditioning.⁷⁸⁸ Finally, resiliency and adaptation are more difficult for economically disadvantaged communities: They tend to have less liquidity, individually and collectively, to move or to make the types of infrastructure or policy changes necessary to limit or reduce the hazards they face. They frequently face systemic, institutional challenges that limit their power to advocate for and receive resources that would otherwise aid in resiliency and hazard reduction and mitigation.

The assessment literature cited in the EPA’s 2009 Endangerment Finding, as well as *Impacts of Climate Change on Human Health*, also concluded that certain populations and people in particular stages of life, including children, are most vulnerable to climate-related health effects. The assessment literature produced from 2016 to the present strengthens these conclusions by providing more detailed findings regarding related vulnerabilities and the projected impacts youth may experience. These assessments—including the NCA4 (2018) and *The Impacts of Climate Change on Human Health in the United States* (2016)—describe how children’s unique physiological and developmental factors contribute to making them particularly vulnerable to climate change. Impacts to children are expected from air pollution, infectious and waterborne illnesses, and mental health effects resulting from extreme weather events. In addition, children are among those especially susceptible to allergens, as well as health effects associated with heat waves, storms, and floods. Additional health concerns may arise in low-income households, especially those with children, if climate change

reduces food availability and increases prices, leading to food insecurity within households. More generally, these reports note that extreme weather and flooding can cause or exacerbate poor health outcomes by affecting mental health because of stress; contributing to or worsening existing conditions, again due to stress or also as a consequence of exposures to water and air pollutants; or by impacting hospital and emergency services operations.⁷⁸⁹ Further, in urban areas in particular, flooding can have significant economic consequences due to effects on infrastructure, pollutant exposures, and drowning dangers. The ability to withstand and recover from flooding is dependent in part on the social vulnerability of the affected population and individuals experiencing an event.⁷⁹⁰ In addition, children are among those especially susceptible to allergens, as well as health effects associated with heat waves, storms, and floods. Additional health concerns may arise in low-income households, especially those with children, if climate change reduces food availability and increases prices, leading to food insecurity within households.

The Impacts of Climate Change on Human Health (USGCRP, 2016) also found that some communities of color, low-income groups, people with limited English proficiency, and certain immigrant groups (especially those who are undocumented) live with many of the factors that contribute to their vulnerability to the health impacts of climate change. While difficult to isolate from related socioeconomic factors, race appears to be an important factor in vulnerability to climate-related stress, with elevated risks for mortality from high temperatures reported for Black or African-American individuals compared to White individuals after controlling for factors such as air conditioning use. Moreover, people of color are disproportionately exposed to air pollution based on where they live, and disproportionately vulnerable due to higher baseline prevalence of underlying diseases such as asthma, so

⁷⁸⁵ EPA. 2021. Climate Change and Social Vulnerability in the United States: A Focus on Six Impacts. U.S. Environmental Protection Agency, EPA 430-R-21-003.

⁷⁸⁶ USGCRP, 2016: *The Impacts of Climate Change on Human Health in the United States: A Scientific Assessment*.

⁷⁸⁷ Ebi, K.L., J.M. Balbus, G. Luber, A. Bole, A. Crimmins, G. Glass, S. Saha, M.M. Shimamoto, J. Trtanj, and J.L. White-Newsome, 2018: Human Health. In *Impacts, Risks, and Adaptation in the United States: Fourth National Climate Assessment, Volume II* [Reidmiller, D.R., C.W. Avery, D.R. Easterling, K.E. Kunkel, K.L.M. Lewis, T.K. Maycock, and B.C. Stewart (eds.)]. U.S. Global Change Research Program, Washington, DC, USA, pp. 539–571. doi:10.7930/NCA4.2018.CH14.

⁷⁸⁸ USGCRP, 2016.

⁷⁸⁹ Ebi, K.L., J.M. Balbus, G. Luber, A. Bole, A. Crimmins, G. Glass, S. Saha, M.M. Shimamoto, J. Trtanj, and J.L. White-Newsome, 2018: Human Health. In *Impacts, Risks, and Adaptation in the United States: Fourth National Climate Assessment, Volume II* [Reidmiller, D.R., C.W. Avery, D.R. Easterling, K.E. Kunkel, K.L.M. Lewis, T.K. Maycock, and B.C. Stewart (eds.)]. U.S. Global Change Research Program, Washington, DC, USA, pp. 539–571. doi:10.7930/NCA4.2018.CH14.

⁷⁹⁰ National Academies of Sciences, Engineering, and Medicine 2019. *Framing the Challenge of Urban Flooding in the United States*. Washington, DC: The National Academies Press. <https://doi.org/10.17226/25381>.

climate exacerbations of air pollution are expected to have disproportionate effects on these communities. Locations with greater health threats include urban areas (due to, among other factors, the “heat island” effect where built infrastructure and lack of green spaces increases local temperatures), areas where airborne allergens and other air pollutants already occur at higher levels, and communities experienced depleted water supplies or vulnerable energy and transportation infrastructure.

The recent EPA report on climate change and social vulnerability⁷⁹¹ examined four socially vulnerable groups (individuals who are low income, minority, without high school diplomas, and/or 65 years and older) and their exposure to several different climate impacts (air quality, coastal flooding, extreme temperatures, and inland flooding). This report found that Black and African-American individuals were 40 percent more likely to currently live in areas with the highest projected increases in mortality rates due to climate-driven changes in extreme temperatures, and 34 percent more likely to live in areas with the highest projected increases in childhood asthma diagnoses due to climate-driven changes in particulate air pollution. The report found that Hispanic and Latino individuals are 43 percent more likely to live in areas with the highest projected labor hour losses in weather-exposed industries due to climate-driven warming, and 50 percent more likely to live in coastal areas with the highest projected increases in traffic delays due to increases in high-tide flooding. The report found that American Indian and Alaska Native individuals are 48 percent more likely to live in areas where the highest percentage of land is projected to be inundated due to sea level rise, and 37 percent more likely to live in areas with high projected labor hour losses. Asian individuals were found to be 23 percent more likely to live in coastal areas with projected increases in traffic delays from high-tide flooding. Those with low income or no high school diploma are about 25 percent more likely to live in areas with high projected losses of labor hours, and 15 percent more likely to live in areas with the highest projected increases in asthma due to climate-driven increases in particulate air pollution, and in areas with high

⁷⁹¹ EPA. 2021. Climate Change and Social Vulnerability in the United States: A Focus on Six Impacts. U.S. Environmental Protection Agency, EPA 430-R-21-003.

projected inundation due to sea level rise.

In a more recent 2023 report, *Climate Change Impacts on Children's Health and Well-Being in the U.S.*, the EPA considered the degree to which children's health and well-being may be impacted by five climate-related environmental hazards—extreme heat, poor air quality, changes in seasonality, flooding, and different types of infectious diseases (U.S. EPA, 2023). The report found that children's academic achievement is projected to be reduced by 4–7 percent per child, as a result of moderate and higher levels of warming, impacting future income levels. The report also projects increases in the numbers of annual emergency department visits associated with asthma, and that the number of new asthma diagnoses increases by 4–11 percent due to climate-driven increases in air pollution relative to current levels. In addition, more than 1 million children in coastal regions are projected to be temporarily displaced from their homes annually due to climate-driven flooding, and infectious disease rates are similarly anticipated to rise, with the number of new Lyme disease cases in children living in 22 states in the eastern and midwestern U.S. increasing by approximately 3,000–23,000 per year compared to current levels. Overall, the report confirmed findings of broader climate science assessments that children are uniquely vulnerable to climate-related impacts and that in many situations, children in the U.S. who identify as Black, Indigenous, and People of Color, are limited English-speaking, do not have health insurance, or live in low-income communities may be disproportionately exposed to the most severe impacts of climate change.

2. Impacts of Climate Change on Indigenous Communities

Indigenous communities face disproportionate risks from the impacts of climate change, particularly those communities impacted by degradation of natural and cultural resources within established reservation boundaries and threats to traditional subsistence lifestyles. Indigenous communities whose health, economic well-being, and cultural traditions depend upon the natural environment will likely be affected by the degradation of ecosystem goods and services associated with climate change. The IPCC indicates that losses of customs and historical knowledge may cause communities to be less resilient or adaptable.⁷⁹² The

⁷⁹² Porter, *et al.*, 2014: Food security and food production systems.

NCA4 (2018) noted that while indigenous peoples are diverse and will be impacted by the climate changes universal to all Americans, there are several ways in which climate change uniquely threatens indigenous peoples' livelihoods and economies.⁷⁹³ In addition, there can be institutional barriers (including policy-based limitations and restrictions) to their management of water, land, and other natural resources that could impede adaptive measures.

For example, indigenous agriculture in the Southwest is already being adversely affected by changing patterns of flooding, drought, dust storms, and rising temperatures leading to increased soil erosion, irrigation water demand, and decreased crop quality and herd sizes. The Confederated Tribes of the Umatilla Indian Reservation in the Northwest have identified climate risks to salmon, elk, deer, roots, and huckleberry habitat. Housing and sanitary water supply infrastructure are vulnerable to disruption from extreme precipitation events. Confounding general Native American response to natural hazards are limitations imposed by policies such as the Dawes Act of 1887 and the Indian Reorganization Act of 1934, which ultimately restrict Indigenous peoples' autonomy regarding land-management decisions through Federal trusteeship of certain Tribal lands and mandated Federal oversight of management decisions. Additionally, NCA4 noted that Indigenous peoples are subjected to institutional racism effects, such as poor infrastructure, diminished access to quality healthcare, and greater risk of exposure to pollutants. Consequently, Native Americans often have disproportionately higher rates of asthma, cardiovascular disease, Alzheimer's disease, diabetes, and obesity. These health conditions and related effects (disorientation, heightened exposure to PM_{2.5}, *etc.*) can all contribute to increased vulnerability to climate-driven extreme heat and air pollution events, which also may be exacerbated by stressful situations, such as extreme weather events, wildfires, and other circumstances.

⁷⁹³ Jantarasami, L.C., R. Novak, R. Delgado, E. Marino, S. McNeeley, C. Narducci, J. Raymond-Yakoubian, L. Singletary, and K. Powys Whyte, 2018: Tribes and Indigenous Peoples. In *Impacts, Risks, and Adaptation in the United States: Fourth National Climate Assessment, Volume II* [Reidmiller, D.R., C.W. Avery, D.R. Easterling, K.E. Kunkel, K.L.M. Lewis, T.K. Maycock, and B.C. Stewart (eds.)]. U.S. Global Change Research Program, Washington, DC, USA, pp. 572–603. doi:10.7930/NCA4. 2018. CH15.

NCA4 and IPCC's Fifth Assessment Report⁷⁹⁴ also highlighted several impacts specific to Alaskan Indigenous Peoples. Coastal erosion and permafrost thaw will lead to more coastal erosion, rendering winter travel riskier and exacerbating damage to buildings, roads, and other infrastructure—impacts on archaeological sites, structures, and objects that will lead to a loss of cultural heritage for Alaska's indigenous people. In terms of food security, the NCA4 discussed reductions in suitable ice conditions for hunting, warmer temperatures impairing the use of traditional ice cellars for food storage, and declining shellfish populations due to warming and acidification. While the NCA4 also noted that climate change provided more opportunity to hunt from boats later in the fall season or earlier in the spring, the assessment found that the net impact was an overall decrease in food security.

3. Environmental Justice Impacts of Ozone Exposure Due to Oil and Natural Gas VOC Impacts

Although EJ concerns for each rulemaking are unique and should be considered on a case-by-case basis, the EPA's EJ Technical Guidance (U.S. EPA, 2015) states that “[t]he analysis of potential EJ concerns for regulatory actions should address three questions:

1. Are there potential EJ concerns associated with environmental stressors affected by the regulatory action for population groups of concern in the baseline?

2. Are there potential EJ concerns associated with environmental stressors affected by the regulatory action for population groups of concern for the regulatory option(s) under consideration?

3. For the regulatory option(s) under consideration, are potential EJ concerns created [, exacerbated,] or mitigated compared to the baseline?”

To address these questions, the EPA developed an analytical approach that considers the purpose and specifics of this proposed rulemaking, as well as the nature of known and potential exposures and health impacts. The purpose of this RIA is to provide estimates of the potential costs and benefits of the illustrative national

control strategies in 2038 for the selected policy option. The selected policy option evaluated in the RIA is expected to reduce VOC emissions. Consequently, this means that ozone formation and exposure is expected to be reduced such that some areas are expected to experience greater air quality improvements, and thus health improvements. As differences in both exposure and susceptibility (*i.e.*, intrinsic individual risk factors) contribute to environmental impacts, the analytical approach used here first determines whether exposure and health effect disparities exist under the baseline scenario. The approach then evaluates if and how disparities are impacted when illustrative emissions control strategies are analyzed. Both the exposure and health effects analyses were developed using available scientific evidence from the selected policy option for the Oil & Gas rule, for the future year 2038, and are associated with various uncertainties. Consistent with the methods the EPA uses to fully characterize the benefits of a regulatory action, these EJ analyses evaluate the full set of exposure and health outcome distributions resulting from this proposed action at the national scale.

The EJ exposure assessment portion of the analysis focuses on associating ambient ozone concentrations with various demographic variables. Because this type of analysis requires less a priori information, we were able to include a broad array of demographic characteristics. Estimating actual health outcomes modified by demographic population requires additional scientific information, which constrained the scope of the second portion of the assessment. We focused the EJ health effects analysis on populations and health outcomes with the strongest scientific support (U.S. EPA, 2019, U.S. EPA, 2020, U.S. EPA, 2022a). However, the EJ health effects analysis does not include information about differences in other factors that could affect the likelihood of adverse impacts (*e.g.*, access to health care, BMI) across groups, due to limitations on the underlying data.⁷⁹⁵ Both the EJ exposure and health effects analyses are subject to uncertainties related to input

parameters and assumptions. For example, both analyses focus on seasonal average ozone concentrations and do not evaluate whether concentrations experienced by different groups persist across the distribution of daily ozone exposures. Additionally, the EJ health effects analysis is subject to additional uncertainties related to concentration-response relationships and baseline incidence data.

Complex analyses using estimated parameters and inputs from numerous models are likely to include multiple sources of uncertainty. As this analysis is based on the same ozone spatial fields as the benefits assessment, it is subject to similar types of uncertainty.

VII. Statutory and Executive Order Reviews

Additional information about these statutes and E.O. can be found at <https://www.epa.gov/laws-regulations/laws-and-executive-orders>.

A. Executive Order 12866: Regulatory Planning and Review and Executive Order 14094: Modernizing Regulatory Review

This action is a “significant regulatory action” as defined under section 3(f)(1) of Executive Order 12866, as amended by Executive Order 14094. Accordingly, the EPA submitted this action to OMB for Executive Order 12866 review. Documentation of any changes made in response to the Executive Order 12866 review is available in the docket for this action. The EPA prepared an analysis of the potential costs and benefits associated with this action. This analysis, “Regulatory Impact Analysis for the Standards of Performance for New, Reconstructed, and Modified Sources and Emissions Guidelines for Existing Sources: Oil and Natural Gas Sector Climate Review,” is available in the docket and describes in detail the EPA's assumptions and characterizes the various sources of uncertainties affecting the estimates.

The PV and EAV of the projected benefits, costs, and net benefits over the 2024 to 2038 period under the final rule using discount rates of 2, 3, and 7 percent is presented in table 28. A discussion of the costs of the final rule is in section 2 of the RIA and a discussion of the benefits is in section 3.

⁷⁹⁴ Porter, *et al.*, 2014: Food security and food production systems.

⁷⁹⁵ We do not ascribe differential health effects to be caused by race or ethnicity. Instead, race and ethnicity likely serve as proxies for a variety of environmental and social stressors.

TABLE 28—BENEFITS, COSTS, NET BENEFITS, AND EMISSIONS REDUCTIONS UNDER THE FINAL RULES, 2024–2038
 [Dollar estimates in millions of 2019 dollars]^a

	2 Percent near-term ramsey discount rate					
	PV	EAV	PV	EAV	PV	EAV
Climate Benefits ^b	\$110,000	\$8,500	\$110,000	\$8,500	\$110,000	\$8,500
	2 Percent discount rate		3 Percent discount rate		7 Percent discount rate	
	PV	EAV	PV	EAV	PV	EAV
Ozone Health Benefits ^c	\$7,000	\$540	\$6,100	\$510	\$3,500	\$380
Net Compliance Costs	19,000	1,500	18,000	1,500	14,000	1,600
<i>Compliance Costs</i>	31,000	2,400	29,000	2,400	22,000	2,400
<i>Value of Product Recovery</i>	13,000	980	11,000	950	7,400	820
Net Benefits ^d	97,000	7,600	97,000	7,500	98,000	7,300
Non-Monetized Benefits	Climate and ozone-related health benefits from reducing 58 million short tons of methane from 2024 to 2038. Benefits to provision of ecosystem services associated with reduced ozone concentrations from reducing 16 million short tons of VOC from 2024 to 2038. PM _{2.5} -related health benefits from reducing 16 million short tons of VOC from 2024 to 2038. HAP benefits from reducing 590 thousand short tons of HAP from 2024 to 2038.					

^a Values rounded to two significant figures. Totals may not appear to add correctly due to rounding.

^b Climate benefits are based on reductions in methane emissions and are calculated using three different estimates of the SC-CH₄ (under 1.5 percent, 2.0 percent, and 2.5 percent near-term Ramsey discount rates). For the presentational purposes of this table, we show the climate benefits associated with the SC-CH₄ at the 2 percent near-term Ramsey discount rate. Please see tables 3.4 and 3.5 in the RIA for the full range of monetized climate benefit estimates. All net benefits are calculated using climate benefits discounted at the 2 percent near-term rate.

^c Monetized benefits include those related to public health associated with reductions in ozone concentrations. The health benefits are associated with several point estimates.

^d Several categories of climate, human health, and welfare benefits from methane, VOC, and HAP emissions reductions remain unmonetized and are thus not directly reflected in the quantified benefit estimates in the table.

B. Paperwork Reduction Act (PRA)

The information collection activities in this rule have been submitted for approval to the OMB under the PRA. The ICR document that the EPA prepared has been assigned OMB Control No. 2060-0721 and EPA ICR number 2523.05. You can find a copy of the ICR in the docket for this rule, and it is briefly summarized here. The information collection requirements are not enforceable until OMB approves them. As noted in section X.N, the templates for the semiannual and annual reports for these subparts will be on the CEDRI website.⁷⁹⁶

40 CFR part 60, subpart OOOOa. The respondents are owners or operators of onshore oil and natural gas affected facilities. For the purposes of this ICR, it is assumed that oil and natural gas affected facilities located in the U.S. are owned and operated by the oil and natural gas industry, and that none of the affected facilities in the U.S. are owned or operated by Federal, state, Tribal, or local government. All affected facilities are assumed to be privately owned for-profit businesses.

The EPA estimates an average of 4,250 respondents will be affected by NSPS OOOOa over the three-year period

(2023–2025). The average annual burden for the recordkeeping and reporting requirements for these owners and operators is 375,338 person-hours, with an average annual cost of \$126,543,957 over the three-year period.

Respondents/affected entities: Oil and natural gas operators and owners.

Respondent's obligation to respond: Mandatory.

Estimated number of respondents: 4,250.

Frequency of response: Varies depending on affected facility.⁷⁹⁷

Total estimated burden: 375,338 hours (per year). Burden is defined at 5 CFR 1320.3(b).

Total estimated cost: \$126,543,957 (2019\$), which includes no capital costs or O&M costs.

40 CFR part 60, subpart OOOOb. The respondents are owners or operators of onshore oil and natural gas affected facilities and third parties that are approved as notifiers of super-emitter emissions events. For the purposes of this ICR, it is assumed that oil and natural gas affected facilities located in the U.S. are owned and operated by the oil and natural gas industry, and that none of the affected facilities in the U.S.

are owned or operated by Federal, state, Tribal, or local government. All affected facilities are assumed to be privately owned for-profit businesses.

The EPA estimates an average of 1,849 respondents will be affected by NSPS OOOOb over the 3-year period 2023–2025. The average annual burden for the recordkeeping and reporting requirements for these owners and operators is 883,625 person-hours, with an average annual cost of \$58,535,262 over the three-year period.

Respondents/affected entities: Oil and natural gas operators and owners; approved third-party notifiers.

Respondent's obligation to respond: Mandatory.

Estimated number of respondents: 1,849.

Frequency of response: Varies depending on affected facility.⁷⁹⁸

Total estimated burden: 883,625 hours (per year). Burden is defined at 5 CFR 1320.3(b).

Total estimated cost: \$58,535,262 (2019\$), which includes \$12,182,846 in capital costs.

40 CFR part 60, subpart OOOOc. This rule does not directly impose specific requirements on oil and natural gas

⁷⁹⁶ <https://www.epa.gov/electronic-reporting-air-emissions/cedri>.

⁷⁹⁷ The specific frequency for each information collection activity within this request is shown in tables 1a through 1d of the Supporting Statement in the public docket.

⁷⁹⁸ The specific frequency for each information collection activity within this request is shown in tables 1a through 1d of the Supporting Statement in the public docket.

facilities located in states or areas of Indian country. The rule also does not impose specific requirements on Tribal governments that have affected facilities located in their area of Indian country. This rule does impose specific requirements on state governments with affected oil and natural gas facilities. The information collection requirements are based on the recordkeeping and reporting burden associated with developing, implementing, and enforcing a plan to limit GHG emissions from existing sources in the oil and natural gas sector. These recordkeeping and reporting requirements are specifically authorized by CAA section 114 (42 U.S.C. 7414). All information submitted to the EPA pursuant to the recordkeeping and reporting requirements for which a claim of confidentiality is made is safeguarded according to Agency policies set forth in 40 CFR part 2, subpart B.

The annual burden for this collection of information for the states (averaged over the first 3 years following promulgation) is estimated to range from 166,000 to 208,000 hours at a total annual labor cost of between \$21 to \$26 million. The annual burden for the Federal government associated with the state collection of information (averaged over the first 3 years following promulgation) is estimated to be 22,520 hours at a total annual labor cost of \$1,399,930. The annual burden for industry (averaged over the first 3 years following promulgation) is estimated to be 2.2 million hours at a total annual labor cost of \$166 million. We realize, however, that some facilities may not incur these costs within the first 3 years and may incur them during the fourth or fifth year instead. Therefore, this ICR presents a conservatively high burden estimate for the initial 3 years following promulgation of the EG. Burden is defined at 5 CFR 1320.3(b).

An agency may not conduct or sponsor, and a person is not required to respond to, a collection of information unless it displays a currently valid OMB control number. The OMB control numbers for the EPA's regulations in 40 CFR are listed in 40 CFR part 9. When OMB approves this ICR, the Agency will announce that approval in the **Federal Register** and publish a technical amendment to 40 CFR part 9 to display the OMB control number for the approved information collection activities contained in this final rule.

C. Regulatory Flexibility Act (RFA)

Pursuant to sections 603 and 609(b) of the RFA, the EPA prepared an initial regulatory flexibility analysis (IRFA) for the proposed rule and convened a Small

Business Advocacy Review (SBAR) Panel to obtain advice and recommendations from small entity representatives that potentially would be subject to the rule's requirements. Summaries of the IRFA and Panel recommendations are presented in the proposed rule at 86 FR 63260 (November 15, 2021) and 87 FR 74702 (December 6, 2022). The complete IRFA is available in the RIA for the December 2022 Supplemental Proposal (see section 4.3 of the RIA).

As required by section 604 of the RFA, the EPA prepared a final regulatory flexibility analysis (FRFA) for this action. The FRFA addresses the issues raised by public comments on the IRFA for the proposed rule. The complete FRFA is available for review in the docket and is summarized here. The scope of the FRFA is limited to the NSPS OOOOb. The impacts of the EG OOOOc are not evaluated here because the EG OOOOc does not place explicit requirements on the regulated industry. Those impacts will be evaluated pursuant to the development of a Federal plan.

The final rulemaking takes a significant step forward in mitigating climate change and improving human health by reducing GHG and VOC emissions from the oil and natural gas industry, specifically the Crude Oil and Natural Gas source category. The oil and natural gas industry is the United States' largest industrial emitter of methane. Human emissions of methane, a potent GHG, are responsible for about one third of the warming due to well-mixed GHGs, the second most important human warming agent after carbon dioxide. The EPA is finalizing the actions described in the preamble in accordance with its legal obligations and authorities following a review directed by E.O. 13990, "Protecting Public Health and the Environment and Restoring Science to Tackle the Climate Crisis," issued on January 20, 2021. The EPA intends for the rulemaking to address the far-reaching harmful consequences and real economic costs of climate change. According to the IPCC, "It is unequivocal that human influence has warmed the atmosphere, ocean and land. Widespread and rapid changes in the atmosphere, ocean, cryosphere and biosphere have occurred." These changes have led to increases in heat waves and wildfire weather, reductions in air quality, more intense hurricanes and rainfall events, and rising sea level. These changes, along with future projected changes, endanger the physical survival, health, economic well-being, and quality of life of people living in America, especially

those in the most vulnerable communities.

The EPA finalizes certain NSPS and to promulgate additional NSPS for both methane and VOC emissions from new oil and natural gas sources in the production, processing, transmission and storage segments of the industry; and promulgates EG to require states to regulate methane emissions from existing sources in those segments. The large amount of methane emissions from the oil and natural gas industry coupled with the adverse effects of methane on the global climate compel immediate regulatory action. The final rule comports with the EPA's CAA section 111 obligation to reduce dangerous pollution and responds to the urgency expressed by the current Congress. With the proposal, the EPA is taking additional steps in the regulation of the Crude Oil and Natural Gas source category to protect human health and the environment.

The significant issues raised in public comments specifically in response to the initial regulatory flexibility analysis came from the Office of Advocacy within the Small Business Administration. In response to the Advocacy's comments, the EPA agreed that issuing a revised IRFA with the December 2022 Supplemental Proposal was warranted, and the revision was published as section 4.3 in the December 2022 Supplemental Proposal RIA. The revised IRFA addressed Advocacy's critiques of the IRFA contained in the November 2021 Proposal RIA by providing a robust discussion of regulatory alternatives related to provisions for the following elements: fugitive emissions requirements, alternative technologies, associated gas requirements, process controller and pumps requirements, and reciprocating compressor requirements. For the final regulatory flexibility analysis, the EPA is also including discussion of regulatory alternatives for centrifugal compressor and liquids unloading requirements. Taken together, this discussion addresses Advocacy's concerns about the insufficiency of the discussion of regulatory alternatives in the November 2021 Proposal IRFA. In addition, the revised IRFA noted that the December 2022 Supplemental Proposal did not require OGI in accordance with the proposed appendix K for production sites. While equipment leaks at gas plants were still proposed to be monitored using OGI in accordance with appendix K in the December 2022 Supplemental Proposal, the burden estimates summarized in the revised IRFA reflected burden associated with appendix K. Finally, the

burden estimates were updated to reflect the proposed NSPS OOOOb.

Following the issuance of the December 2022 Supplemental Proposal, Advocacy provided additional comments. While noting that it continued to have significant concerns about the impact the rule would have on small businesses in the oil and gas production sector, Advocacy acknowledged the work that the EPA did to improve its RFA compliance through the IRFA between proposals. More detailed responses to Advocacy's comments can be found in Chapter 21 of both Volume I and Volume II of the RTC document.

The RFA defines small entities as including "small businesses," "small governments," and "small organizations" (5 U.S.C. 601). The regulatory revisions being considered by the EPA for this rulemaking are expected to affect a variety of small businesses but would not affect any small governments or small organizations. The RFA references the definition of "small business" found in the Small Business Act, which authorizes the Small Business Administration (SBA) to further define "small business" by regulation. The detailed listing of SBA definitions of small business for oil and natural gas industries or sectors, by NAICS code, that are potentially affected by this proposal is included in table 4–12 of the RIA. The EPA conducted this initial regulatory flexibility analysis at the ultimate (*i.e.*, highest) level of ownership, evaluating ultimate parent entities.

To estimate the number of small businesses potentially impacted by the rule, the EPA developed a list of operators of oil and natural gas wells, natural gas processing plants, and natural gas compressor stations. The initial list of operators included 1,451 well site operators that completed a well in 2019, 297 processing plant operators, and 574 compressor station operators. The EPA then conducted a small business coding exercise as shown in table 4–13 of the RIA. In total, 998 of the 1,451 well site operators (69 percent) matched to 914 ultimate parent companies; 270 of 297 processing plant operators (91 percent) matched to 149 ultimate parent companies; and 519 of 574 compressor station operators (90 percent) matched to 315 ultimate parent companies.

To estimate the compliance cost impacts of the proposed rule on small entities, the EPA used the dataset of operators matched to ultimate parent companies discussed in the previous section and apply the sum of

incremental costs for all relevant affected facility categories. Because the incremental costs depend on unknown characteristics of operator-specific well sites, processing plants, and compressor stations, we use average equipment counts at each facility type to derive estimates of average impacts at each facility type. Ultimately, the EPA estimated cost-to-sales ratios for each small entity to summarize the impacts of the proposed NSPS. See information and results presented in tables 4–14 to 4–16 of the RIA.

Prior to the November 2021 Proposal, the EPA convened a SBAR Panel to obtain recommendations from small entity representatives on elements of the regulation. The Panel identified significant alternatives for consideration by the Administrator of the EPA, which were summarized in a final report.⁷⁹⁹ Based on the Panel recommendations, as well as comments received in response to the November 2021 Proposal and December 2022 Supplemental Proposal, the EPA is finalizing several regulatory alternatives that could accomplish the stated objectives of the CAA while minimizing any significant economic impact of the final rule on small entities. While the RIA included a full detailed discussion of these alternatives, the EPA is including two examples below.

First, as described in section XI.A. of this preamble, the EPA finalizing certain changes to the fugitives emissions standards that were proposed in November 2021 for NSPS OOOOb and revised in the December 2022 Supplemental Proposal. The EPA believes that two of these proposed changes will reduce impacts on small businesses: (1) requiring OGI monitoring for well sites and centralized production facilities following the monitoring plan required in proposed 40 CFR 60.5397b instead of requiring the procedures being proposed in appendix K for these sites and (2) defining monitoring technique and frequency based on the equipment present at a well site. The EPA describes these two changes below.

In the final rule, the EPA is not requiring OGI monitoring in accordance with the proposed appendix K for well sites or centralized production facilities, as was proposed in the November 2021 Proposal. Instead, the EPA is requiring OGI surveys following the procedures specified in the regulatory text for NSPS OOOOb (at 40 CFR 60.5397b) or according to EPA Method 21. This change is consistent with the requirements for OGI surveys found in

NSPS OOOOb at 40 CFR 60.5397a. This final change is a result of the extensive comments the EPA received from oil and natural gas operators and other groups on the numerous complexities associated with following the proposed appendix K, especially considering the remoteness and size of many of these well sites.⁸⁰⁰ In addition, commenters pointed out that OGI has always been the BSER for fugitive monitoring at well sites and was never designed as a replacement for EPA Method 21, while appendix K was designed for use at more complex processing facilities that have historically been subject to monitoring following EPA Method 21. The EPA agrees with the commenters and is finalizing requirements within NSPS OOOOb at 40 CFR 60.5397b in lieu of the procedures in appendix K for fugitive emissions monitoring at well sites or centralized production facilities. See section X.I.V of the preamble for additional information on what the EPA is finalizing for appendix K related to other sources (*e.g.*, natural gas processing plants). The EPA believes this will particularly benefit small entities because it will streamline the requirements for conducting and documenting OGI surveys at these smaller, less complex sites. Additionally, this change provides a uniform set of requirements for regulated entities that may have assets subject to different subparts within the same region, which leads to increased regulatory certainty and eases the compliance burden. At the same time, the EPA believes this does not compromise the stated objectives of the Clean Air Act because these same requirements are already allowed in NSPS OOOOb and outline many of the same data elements required by appendix K.

Next, the final rule includes fugitive monitoring frequencies and detection techniques that are based on the type of equipment located at a well site, instead of the baseline methane emissions threshold that was included in the November 2021 Proposal and revised in the December 2022 Supplemental Proposal. Specifically, the EPA is finalizing four distinct subcategories of well sites:

- Well sites with only a single wellhead,
- Small well sites with a single wellhead and only one piece of major

⁸⁰⁰ See final rule preamble section XI.A. and see Document ID Nos. EPA-HQ-OAR-2021-0317-0579, -0743, -0764, -0777, -0782, -0786, -0793, -0802, -0807, -0808, -0810, -0814, -0817, -0820, -0831, -0834, and -0938.

⁷⁹⁹ See Document ID EPA-HQ-OAR-2021-0317-0074.

production and processing equipment.⁸⁰¹

- Well sites with only two or more wellheads and no other major production and processing equipment, and
- Well sites with one or more controlled storage vessels, control devices, natural gas-driven pneumatic controllers or pumps, or two or more other major production and processing equipment, including centralized production facilities.

The EPA is finalizing these distinct subcategories of well sites after consideration of comments on the November 2021 Proposal and the December 2022 Supplemental Proposal that stated the original baseline methane emissions threshold approach would be difficult to implement, especially for small businesses that may be less familiar with the use of emission factors from the EPA's Greenhouse Gas Reporting Program. The EPA believes that owners and operators, including small entities, can readily identify the number and types of major equipment located at a well site without the need for complicated calculations of emissions.

Further, the EPA is finalizing specific monitoring frequencies and techniques as the BSER for each well site subcategory individually. For example, the EPA is finalizing the use of audible, visual, and olfactory (AVO) inspections at well sites containing only a single wellhead and at small well sites. This monitoring technique does not require specialized equipment or operator training, but does allow the identification of large leaks, which are of the most concern from an environmental standpoint. Further, AVO monitoring can easily be built into regular maintenance activities that are

designed to keep the equipment at the site in good working order. The final requirements are responsive to a SER recommendation that the EPA allow AVO and soap bubble tests as an option for finding fugitive emissions, particularly because they are low cost and easy to implement alternatives for detecting leaks, and an Advocacy recommendation that the EPA allow AVO as an alternative in limited circumstances, such as part of an off-ramp for facilities unlikely to emit more than insignificant methane or with a demonstrated history of insignificant emissions. The EPA believes this will particularly benefit small entities because AVO surveys at these types of well sites are effective at identifying the types of large emissions from sources located at these well sites at a much lower cost than OGI surveys. For example, the costs associated with the quarterly AVO inspections are estimated at \$660/year, whereas the costs associated with an annual OGI survey for this type of well site are estimated at approximately \$2,000/yr. Inspections via AVO allow for more frequent inspections for large emissions events at these well sites, which results in faster emissions mitigation, than a single OGI survey each year.

In a second example, in the November 2021 Proposal, the EPA proposed that an owner or operator of a reciprocating compressor affected facility would be required to monitor the rod packing emissions annually by conducting flow rate measurements. When the measured flow rate exceeded 2 scfm (in pressurized mode), replacement of the rod packing would have been required. Alternatively, the November 2021 Proposal would have also provided owners and operators the option of routing rod packing emissions to a process via a closed vent system under negative pressure in order to comply with the rule. The proposed option to route to a process would have been allowed as an alternative under NSPS OOOOb because implementing this option, where feasible, would achieve greater emission reductions than the proposed performance-based emissions threshold standard. The December 2022 Supplemental Proposal proposed changes and specific clarifications to the November 2021 Proposal standards for NSPS OOOOb. For the proposed replacement of the rod packing based on an emission limit and annual measurement requirement, we proposed: (1) To clarify that the standard of performance is a numeric standard (not a work practice standard) of 2 scfm, (2) to allow for repair (in

addition to replacement) of the rod packing in order to maintain an emission rate at or below 2 scfm, and (3) to allow for monitoring based on 8,760 hours of operation instead of based on a calendar year. The EPA also proposed regulatory text that defined the required flow rate measurement methods and/or procedure requirements, and recordkeeping and reporting requirements. For the alternative option of routing rod packing emissions to a process via a closed vent system under negative pressure, the EPA proposed to remove the negative pressure requirement.

As described in the preamble to the final rule,⁸⁰² the EPA is finalizing changes to the proposed requirements for reciprocating compressors in for NSPS OOOOb as a result of comments received on the November 2021 Proposal and December 2022 Supplemental Proposal. The EPA believes the following rule changes will reduce impacts on small businesses.

Concerns were expressed regarding the EPA's November 2021 Proposal and December 2022 Supplemental Proposal that shifted rod packing changeout requirements from a designated schedule of once every 3 years to a performance standard based on an annual flow rate measurement. While the November 2021 Proposal format of the performance standard based on volumetric flow rate measurements was as a work practice standard, the December 2022 Supplemental Proposal format of the performance standard was as a numeric standard. Commenters on the December 2022 Supplemental Proposal expressed that, as a numeric standard, the performance standard based on flow measurements was unworkable. It was also noted that a performance standard is often more expensive than a fixed equipment change-out standard because of the additional monitoring and recordkeeping necessary to demonstrate compliance with the performance standard, which they believed could negatively impact small businesses. These commenters also supported the fixed schedule rod packing change-out standard because this is the standard owners and operators have implemented for reciprocating compressors under NSPS OOOOa and stated that the annual flow rate performance work practice standard would lead to more rod packing changeouts than would be required based on the November OOOOa fixed-schedule packing change out requirements.

⁸⁰¹ Small well sites are defined as single wellhead well sites that do not contain any controlled storage vessels, control devices, pneumatic controller affected facilities, or pneumatic pump affected facilities, and include only one other piece of major production and processing equipment. Major production and processing equipment that would be allowed at a small well site would include a single separator, glycol dehydrator, centrifugal and reciprocating compressor, heater/treater, and storage vessel that is not controlled. By this definition, a small well site could only potentially contain a well affected facility (for well completion operations or gas well liquids unloading operations that do not utilize a CVS to route emissions to a control device) and a fugitive emissions components affected facility. No other affected facilities, including those utilizing CVS (such as pneumatic pumps routing to control) can be present for a well site to meet the definition of a small well site. The EPA is soliciting comment on this definition for small well sites, including whether additional metrics should be used beyond equipment counts, as well as the proposed standards and requirements for this subcategory of sites.

⁸⁰² See final rule preamble section XI.I.

The EPA is finalizing the following requirement changes associated with the reciprocating compressor rod packing volumetric flow rate measurement performance standard based on November 2021 Proposal and December 2022 Supplemental Proposal comments: (1) a 2 scfm volumetric flow rate per cylinder performance work practice standard, (2) repair (in addition to replacement) of the rod packing is allowed to maintain an emission rate at or below 2 scfm per cylinder; and (3) monitoring based on 8,760 hours of operation instead of based on a calendar year. These final requirements for reciprocating compressors are responsive to comments and concerns expressed by industry (including small businesses).

The EPA believes the final rule 2 scfm volumetric flow rate per cylinder performance work practice standard approach benefits small entities because facilities can use monitoring data to determine emission levels at which it is necessary to repair or replace rod packing. This approach can result in operational benefits, including a longer life for existing equipment, improvements in operating efficiencies, and long-term cost savings. Allowing an owner or operator to repair the rod packing (in addition to replacement of the rod packing) to maintain an emission rate at or below 2 scfm per cylinder alleviates the need to replace the rod packing when only a simple repair may be needed to maintain volumetric flow rate at or below 2 scfm per cylinder. Requiring owners and operators to conduct volumetric flow rate monitoring based on 8,760 hours of operation instead of based on a calendar year reduces the burden on owners and operators where compressors are not operational for multiple months or are used intermittently. Additionally, by requiring that monitoring frequency based on hours of operation, owners and operators have the flexibility to stagger maintenance activity throughout the year. The final rule defines the required flow rate measurement methods and/or procedures, repair and replacement requirements, and recordkeeping and reporting requirements.

In addition, the following regulatory options have been added to the final rule: (1) owners and operators are allowed to change out reciprocating compressor rod packing every 8,760 hours of operation in lieu of conducting volumetric flow rate monitoring every 8,760 hours; and (2) owners and operators are allowed to route emissions to a control device via a closed vent system in addition to routing emissions via a closed vent system to a process.

For the alternative option of routing rod packing emissions to a process via a closed vent system under negative pressure, the EPA is finalizing the removal of the negative pressure requirement. By allowing owners and operators to change out rod packing every 8,760 hours of operation in lieu of conducting volumetric flow rate monitoring every 8,760 hours, owners and operators have the option to choose a more-stringent rod packing change out schedule (on or before every 8,760 hours of operation) and avoid the need to conduct volumetric flow rate monitoring. Lastly, by the final rule allowing owners and operators to route emissions to a control device in addition to routing emissions to a process, the EPA has added flexibility to the compliance options available for owners and operators.

In addition, the EPA is preparing a Small Entity Compliance Guide to help small entities comply with this rule. The guide will be available on the 60 days after publication of the final rule at <https://www.epa.gov/controlling-air-pollution-oil-and-natural-gas-industry/implementation-oil-and-natural-gas-air>.

D. Unfunded Mandates Reform Act (UMRA)

The NSPS contains a Federal mandate under UMRA, 2 U.S.C. 1531–1538, that may result in expenditures of \$100 million or more for state, Tribal, and local governments, in the aggregate, or the private sector in any 1 year. Accordingly, the EPA has prepared under section 202 of the UMRA a written statement of the benefit-cost analysis, which can be found in section XVI of this preamble, and in Chapter 1 of the RIA.

Consistent with section 205 of UMRA, the EPA has identified and considered a reasonable number of regulatory alternatives. These alternatives are described in section XI of this preamble.

The EG is promulgated under CAA section 111(d) and does not impose any direct compliance requirements on designated facilities, apart from the requirement for states to develop state plans. As explained in section XIV.G of the November 2021 Proposal⁸⁰³ and section V of the December 2022 Supplemental Proposal, the EG also does not impose specific requirements on Tribal governments that have designated facilities located in their area of Indian country. The burden for states to develop state plans following promulgation of the rule is estimated to be below \$100 million in any 1 year.

⁸⁰³ See 86 FR 63256 (November 15, 2021) and 87 FR 74702 (December 6, 2022).

Thus, the EG is not subject to the requirements of section 203 or section 205 of the UMRA.

The NSPS and EG are also not subject to the requirements of section 203 of UMRA because, as described in 2 U.S.C. 1531–38, they contain no regulatory requirements that might significantly or uniquely affect small governments. Specifically, for the EG the state governments to which rule requirements apply are not considered small governments. In light of the interest among governmental entities, the EPA conducted outreach with national organizations representing states and Tribal governmental entities while formulating the proposed rule as discussed in the November 2021 Proposal, the December 2022 Supplemental Proposal, and section VII of this final preamble.⁸⁰⁴ The EPA considered the stakeholders' experiences and lessons learned to help inform how to better structure this final rule and consider ongoing challenges that will require continued collaboration with stakeholders.

E. Executive Order 13132: Federalism

The final NSPS OOOO, OOOOa, and OOOOb and final EG OOOOc do not have federalism implications. These actions will not have substantial direct effects on the states as defined in the E.O., on the relationship between the Federal Government and the states, or on the distribution of power and responsibilities among the various levels of government.

F. Executive Order 13175: Consultation and Coordination With Indian Tribal Governments

This action has Tribal implications. However, it will neither impose substantial direct compliance costs on federally recognized Tribal governments, nor preempt Tribal law, and does not have substantial direct effects on one or more Indian Tribes, the relationship between the Federal Government and Indian Tribes or on the distribution of power and responsibilities between the Federal Government and Indian Tribes, as specified in E.O. 13175. See 65 FR 67249 (November 9, 2000). As stated in the November 2021 Proposal, the EPA found that 112 unique Tribal lands are located within 50 miles of an affected oil and natural gas source, and 32 Tribes have one or more oil or natural gas sources on their lands.⁸⁰⁵ While many of the affected and designated facilities impacted by final NSPS and EG on

⁸⁰⁴ See 86 FR 63145 (November 15, 2021).

⁸⁰⁵ 86 FR 63143 (November 15, 2021).

Tribal lands are owned by private entities, some Tribes also own affected and or designated facilities. There would be Tribal implications associated with this rulemaking in the case where a unit is owned by a Tribal government or in the case of the NSPS, a Tribal government is given delegated authority to enforce the rulemaking. Tribes are not required to develop plans to implement the EG under CAA section 111(d) for designated existing sources. The EPA notes that this final rule does not directly impose specific requirements on designated facilities, including those located in Indian country. Before developing any standards for sources on Tribal land, the EPA would consult with leaders from affected Tribes.

Tribal consultations were completed after the November 2021 Proposal at the request of the Northern Arapahoe Tribe, MHA Nation, and Eastern Shoshone Tribe.⁸⁰⁶ Additional Tribal consultation was completed at the request of MHA Nation and an informational meeting was held with the Ute Tribe after the December 2022 Supplemental Proposal.⁸⁰⁷ Consistent with previous actions affecting the Crude Oil and Natural Gas source category, the EPA understands there is continued significant Tribal interest because of the growth of the oil and natural gas production in Indian country. In accordance with the EPA Policy on Consultation and Coordination with Indian Tribes, the EPA will continue to engage in consultation with Tribal officials as these rules become implemented.

G. Executive Order 13045: Protection of Children From Environmental Health Risks and Safety Risks

This action is subject to E.O. 13045 (62 FR 19885, April 23, 1997) because it is a significant regulatory action as defined by E.O. 12866(3)(f)(1), and the EPA believes that the environmental health or safety risk addressed by this action has a disproportionate effect on children. Accordingly, the Agency has evaluated the environmental health and welfare effects of climate change on children. GHGs, including methane, contribute to climate change and are emitted in significant quantities by the oil and gas industry. The EPA believes that the GHG emission reductions resulting from implementation of these standards and guidelines will further improve children's health. The assessment literature cited in the EPA's

2009 Endangerment Findings concluded that certain populations and life stages, including children, the elderly, and the poor, are most vulnerable to climate-related health effects (74 FR 66524, December 15, 2009). The assessment literature since 2009 strengthens these conclusions by providing more detailed findings regarding these groups' vulnerabilities and the projected impacts they may experience (e.g., the 2016 Climate and Health Assessment⁸⁰⁸). These assessments describe how children's unique physiological and developmental factors contribute to making them particularly vulnerable to climate change. Impacts to children are expected from heat waves, air pollution, infectious and waterborne illnesses, and mental health effects resulting from extreme weather events. In addition, children are among those especially susceptible to most allergic diseases, as well as health effects associated with heat waves, storms, and floods. Additional health concerns may arise in low-income households, especially those with children, if climate change reduces food availability and increases prices, leading to food insecurity within households. More detailed information on the impacts of climate change to human health and welfare is provided in sections III and VI of the November 2021 Proposal,⁸⁰⁹ section VII of the December 2022 Supplemental Proposal,⁸¹⁰ and section XVI of this document. Under the final NSPS OOOOb and EG OOOOc, the EPA expects that VOC and methane emissions reductions will improve air quality and mitigate climate impacts which will benefit the health and welfare of children.

H. Executive Order 13211: Actions Concerning Regulations That Significantly Affect Energy Supply, Distribution, or Use

This action, which is a significant regulatory action under E.O. 12866, has a significant adverse effect on the supply, distribution or use of energy as that phrase is defined in E.O. 13211. The documentation for this decision is contained in section 4.1.4 of the *Regulatory Impact Analysis for the Standards of Performance for New,*

Reconstructed, and Modified Sources and Emissions Guidelines for Existing Sources: Oil and Natural Gas Sector Climate Review for this final action. To make this determination, we compare the projected change in crude oil and natural gas production to guidance articulated in a January 13, 2021, OMB memorandum, *Furthering Compliance with Executive Order 13211, Titled "Actions Concerning Regulations That Significantly Affect Energy Supply, Distribution, or Use."*⁸¹¹ With respect to crude oil production, the guidance indicates that a regulatory action produces a significant adverse effect if it is expected to produce reductions in crude oil supply in excess of 20 million barrels per year. With respect to natural gas production, the guidance indicates that a regulatory action produces a significant adverse effect if it reduces natural gas production in excess of 40 million mcf per year.⁸¹² We estimate maximum production reductions of about 41.4 million barrels of crude oil (1.05 percent of projected baseline production) and 272.5 million Mcf per year (0.75 percent).

I. National Technology Transfer and Advancement Act (NTTAA) and 1 CFR Part 51

This rulemaking involves technical standards. Therefore, the EPA conducted searches for the Standards of Performance for New, Reconstructed, and Modified Sources and Emissions Guidelines for Existing Sources: Oil and Natural Gas Sector Climate Review through the Enhanced National Standards Systems Network (NSSN) Database managed by the American National Standards Institute (ANSI). Searches were conducted for EPA Methods 1, 1A, 2, 2A, 2C, 2D, 3A, 3B, 3C, 4, 6, 10, 15, 16, 16A, 18, 21, 22, 25A of 40 CFR part 60, appendix A, EPA-454/B-08-002, and EPA-600/R-12/531. No applicable voluntary consensus standards (VCS) were identified for EPA Methods 1A, 2A, 2D, 21, and 22 and none were brought to its attention in comments. All potential standards were reviewed to determine the practicality of the VCS for this rule. Two VCS were

⁸¹¹ See <https://www.whitehouse.gov/wp-content/uploads/2021/01/M-21-12.pdf>.

⁸¹² The 2021 E.O. 13211 guidance memo states that the natural gas production decrease that indicates the regulatory action is a significant energy action is 40 mcf per year. Because this is a relatively small amount of natural gas and previous guidance from 2001 indicated a threshold of 25 million Mcf, we assume the 2021 memo was intended to establish 40 million Mcf as the indicator of an adverse energy effect. See <https://www.whitehouse.gov/wp-content/uploads/2017/11/2001-M-01-27-Guidance-for-Implementing-E.O.-13211.pdf>.

⁸⁰⁸ USGCRP, 2016: The Impacts of Climate Change on Human Health in the United States: A Scientific Assessment. Crimmins, A., J. Balbus, J.L. Gamble, C.B. Beard, J.E. Bell, D. Dodgen, R.J. Eisen, N. Fann, M.D. Hawkins, S.C. Herring, L. Jantarasami, D.M. Mills, S. Saha, M.C. Sarofim, J. Trtanj, and L. Ziska, Eds. U.S. Global Change Research Program, Washington, DC, 312 pp. <http://dx.doi.org/10.7930/JOR49NQX>.

⁸⁰⁹ See 86 FR 63124 and 86 FR 63139 (November 15, 2021).

⁸¹⁰ See 87 FR 74702 (December 6, 2022).

⁸⁰⁶ See Memorandum in EPA-HQ-OAR-2021-0317.

⁸⁰⁷ See Memorandum in EPA-HQ-OAR-2021-0317.

identified as an acceptable alternative to EPA test methods for the purpose of this rule. First, ANSI/ASME PTC 19–10–1981, Flue and Exhaust Gas Analyses (Part 10) (manual portions only and not the instrumental portion) was identified to be used in lieu of EPA Methods 3B, 6, 6A, 6B, 15A and 16A. This standard includes manual and instrumental methods of analysis for CO₂, carbon monoxide (CO), H₂S, NO_x, O₂, and SO₂. Second, ASTM International (ASTM) D6420–99 (2010), “Test Method for Determination of Gaseous Organic Compounds by Direct Interface Gas Chromatography/Mass Spectrometry” is an acceptable alternative to EPA Method 18 with the following caveats, only use when the target compounds are all known, and the target compounds are all listed in ASTM D6420 as measurable. ASTM D6420 should never be specified as a “total VOC” Method. (ASTM D6420–99 (2010) is not incorporated by reference in 40 CFR part 60.) The search identified 19 VCS that were potentially applicable for this proposed rule in lieu of EPA reference methods. However, these have been determined to not be practical due to lack of equivalency, documentation, validation of data and other important technical and policy considerations. For additional information, please see the September 10, 2021, memo titled, “Voluntary Consensus Standard Results for New, Reconstructed, and Modified Sources and Emissions Guidelines for Existing Sources: Oil and Natural Gas Sector Climate Review.”⁸¹³ In this rule, the EPA is including regulatory text for 40 CFR part 60, subparts OOOOb and OOOOc that includes incorporation by reference. In accordance with requirements of 40 CFR 60.17, the EPA is incorporating the following sixteen standards by reference.

- ASME/ANSI PTC 19.10–1981, Flue and Exhaust Gas Analyses [Part 10, Instruments and Apparatus] (Issued August 31, 1981) covers measuring the O₂ or CO₂ content of the exhaust gas. It highlights and specifies methods, apparatus, and calculations which are used in conjunction with Performance Test Codes to determine quantitatively, the gaseous constituents of exhausts resulting from stationary combustion sources. The PTC Supplement also describes the most commonly used instrumentation and analytical procedures used for flue and exhaust gas analyses.

- ASTM D86–96, Distillation of Petroleum Products (Approved April 10, 1996) covers the distillation of natural

gasolines, motor gasolines, aviation gasolines, aviation turbine fuels, special boiling point spirits, naphthas, white spirit, kerosine, gas oils, distillate fuel oils, and similar petroleum products, utilizing either manual or automated equipment.

- ASTM D1945–03 (Reapproved 2010), Standard Test Method for Analysis of Natural Gas by Gas Chromatography covers the determination of the chemical composition of natural gases and similar gaseous mixtures within a certain range of composition. This test method may be abbreviated for the analysis of lean natural gases containing negligible amounts of hexanes and higher hydrocarbons, or for the determination of one or more components.

- ASTM D1945–14 (Reapproved 2019), Standard Test Method for Analysis of Natural Gas by Gas Chromatography covers the determination of the chemical composition of natural gases and similar gaseous mixtures within a certain range of composition. This test method may be abbreviated for the analysis of lean natural gases containing negligible amounts of hexanes and higher hydrocarbons, or for the determination of one or more components.

- ASTM D2879–83, Test Method for Vapor Pressure-Temperature Relationship and Initial Decomposition Temperature of Liquids by Isoteniscope. This test method covers the determination of the vapor pressure of pure liquids, the vapor pressure exerted by mixtures in a closed vessel at 40 +/- 5 percent ullage, and the initial thermal decomposition temperature of pure and mixed liquids.

- ASTM D2879–96, Test Method for Vapor Pressure-Temperature Relationship and Initial Decomposition Temperature of Liquids by Isoteniscope. This method is a revision of ASTM D2879–83. It is suited for use over a wide range of temperature ranging from ambient to 748 K and can include below ambient temperature when suitable constant-temperature bath for such temperature is used.

- ASTM D2879–97, Test Method for Vapor Pressure-Temperature Relationship and Initial Decomposition Temperature of Liquids by Isoteniscope. This method is a revision of ASTM D2879–96. Most petroleum products boil over a fairly wide temperature range and an ideal combination will show a progressive reduction in vapor pressure as lighter fluid components and may exert pressure in a closed system. This test method is simulated in the isoteniscope -a constant volume apparatus.

- ASTM D3588–98 (Reapproved 2003), Standard Practice for Calculating Heat Value, Compressibility Factor, and Relative Density of Gaseous Fuel covers procedures for calculating heating value, relative density, and compressibility factor at base conditions for natural gas mixtures from compositional analysis. It applies to all common types of utility gaseous fuels.

- ASTM D4891–89 (Reapproved 2006), Standard Test Method for Heating Value of Gases in Natural Gas Range by Stoichiometric Combustion covers the determination of the heating value of natural gases and similar gaseous mixtures within a certain range of composition.

- ASTM D6348–12e1, Standard Test Method for Determination of Gaseous Compounds by Extractive Direct Interface Fourier Transform Infrared (FTIR) Spectroscopy. This field test method employs an extractive sampling system to direct stationary source effluent to an FTIR spectrometer for the identification and quantification of gaseous compounds. Also, this method employs converting the volume concentration to a mass emission rate utilizing a compound’s molecular weight, and the effluent volumetric flow rate, temperature and pressure in determining the impact of that particular compound to the atmosphere.

- ASTM D6522–20, Standard Test Method for Determination of Nitrogen Oxides, Carbon Monoxide, and Oxygen Concentrations in Emissions from Natural Gas-Fired Reciprocating Engines, Combustion Turbines, Boilers, and Process Heaters Using Portable Analyzers covers the determination of NO_x, CO, and O₂ concentrations in controlled and uncontrolled emissions from natural gas-fired reciprocating engines, combustion turbines, boilers, and process heaters.

- ASTM E168–16 (Reapproved 2023), Standard Practices for General Techniques of Infrared Quantitative Analysis covers the techniques most often used in infrared quantitative analysis. Practices associated with the collection and analysis of data on a computer are included as well as practices that do not use a computer.

- ASTM E169–16 (Reapproved 2022), Standard Practices for General Techniques of Ultraviolet Quantitative Analysis provide general information on the techniques most often used in ultraviolet and visible quantitative analysis. The purpose is to render unnecessary the repetition of these descriptions of techniques in individual methods for quantitative analysis.

- ASTM E260–96, General Gas Chromatography Procedures is a general

⁸¹³ See Document ID No. EPA–HQ–OAR–2021–0317–0072.

guide to the application of gas chromatography with packed columns for the separation and analysis of vaporizable or gaseous organic and inorganic mixtures and as a reference for the writing and reporting of gas chromatography methods.

- EPA-454/B-08-002, Quality Assurance Handbook for Air Pollution Measurement Systems Volume IV: Meteorological Measurements Version 2.0 (Final), March 2008. This guidance is designed to provide clear and concise information to the State/Local/Tribal (SLT) air pollution control agencies that operate meteorological monitoring equipment and systems.

- EPA-600/R-12/531, EPA Traceability Protocol for Assay and Certification of Gaseous Calibration Standards (Issued May 2012) is mandatory for certifying the calibration gases being used for the calibration and audit of ambient air quality analyzers and continuous emission monitors that are required by numerous parts of the CFR.

The EPA determined that the ASTM and ASME/ANSI standards, notwithstanding the age of the standards, are reasonably available because they are available for purchase from the following addresses: ASTM International 100 Barr Harbor Drive, Post Office Box C700, West Conshohocken, PA 19428-2959, +1.610.832.9500, www.astm.org; or ProQuest, 300 North Zeeb Road, Ann Arbor, MI 48106, +1.877.779.6768, www.proquest.com; and the American Society of Mechanical Engineers (ASME), Three Park Avenue, New York, NY 10016-5990, +1.800.843.5990, customer-care@asme.org, www.asme.org. The EPA determined that the EPA standard is reasonably available because it is publicly available through the EPA's website: <https://nepis.epa.gov/Adobe/PDF/P100EKJR.pdf>.

J. Executive Order 12898: Federal Actions To Address Environmental Justice in Minority Populations and Low-Income Populations and Executive Order 14096: Revitalizing Our Nation's Commitment to Environmental Justice for All

The EPA believes that the human health or environmental conditions that exist prior to this action result in or have the potential to result in disproportionate and adverse human health or environmental effects on communities with EJ concerns. With respect to exposure to ambient ground-level ozone, the baseline scenario is similar to that described by other RIAs in that there are small but disproportionate and adverse effects on

some populations analyzed including American Indians, Asians, Hispanics, those who are Linguistically isolated, those living in Redlined areas, and those living on Tribal land. On average, these demographic groups are exposed to at least 0.9 ppb (and at most 2.0 ppb) higher ozone concentrations than the reference population.

As described above, this final rulemaking will result in reductions in VOCs, which are an important precursor contributing to ground-level ozone formation in many regions of the country. VOC emissions from oil and gas operations are believed to be a factor contributing to elevated ozone levels in multiple areas of the country including Colorado, New Mexico, Texas, Utah and Wyoming. Although the EPA's analysis indicates that the final rulemaking will have relatively small effects on ambient ozone concentrations when compared to baseline conditions, the EPA nonetheless anticipates that communities with environmental justice concerns will benefit from reductions in VOC emissions that contribute to ozone formation in diverse areas of the country.

At the same time, the reductions in ozone concentrations that will result from this rulemaking are expected to be evenly distributed across most demographic groups. The EPA believes that this action is likely to reduce existing disproportionate and adverse effects on people who live on Tribal lands in some states (most notably Colorado). However, for all other demographic groups and geographic locations, the EPA believes this action is not likely to meaningfully change existing disproportionate and adverse effects. The reductions in ozone concentrations due to the policy option are similar in magnitude across most demographic groups and small relative to baseline conditions, such that it is unlikely that the policy option will exacerbate or mitigate any disproportionate exposures to ozone that were present at baseline.

The documentation for this assessment is contained in section 4 of the *Regulatory Impact Analysis for the Proposed Standards of Performance for New, Reconstructed, and Modified Sources and Emissions Guidelines for Existing Sources: Oil and Natural Gas Sector Climate Review* prepared for the November 2021 Proposal,⁸¹⁴ in section 4 of the *Regulatory Impact Analysis of the Supplemental Proposal for the Standards of Performance for New, Reconstructed, and Modified Sources*

and *Emissions Guidelines for Existing Sources: Oil and Natural Gas Sector Climate Review* prepared for the December 2022 Supplemental Proposal,⁸¹⁵ and in section 4 of the *Regulatory Impact Analysis for the Standards of Performance for New, Reconstructed, and Modified Sources and Emissions Guidelines for Existing Sources: Oil and Natural Gas Sector Climate Review* prepared for this action.

This rulemaking will also reduce methane pollution that contributes to climate change, which itself has substantial and adverse impacts on environmental justice communities. Methane emissions represent a significant share of total GHG emissions and hence are a major contributor to climate change. In 2009, under the Endangerment and Cause or Contribute Findings for Greenhouse Gases Under Section 202(a) of the Clean Air Act ("Endangerment Finding"), the Administrator considered how climate change threatens the health and welfare of the U.S. population. As part of that consideration, she also considered risks to people of color and low-income individuals and communities, finding that certain parts of the U.S. population may be especially vulnerable based on their characteristics or circumstances. These groups include economically and socially vulnerable communities; individuals at vulnerable life stages, such as the elderly, the very young, and pregnant or nursing women; those already in poor health or with comorbidities; the disabled; those experiencing homelessness, mental illness, or substance abuse; and/or Indigenous or people of color dependent on one or limited resources for subsistence due to factors including but not limited to geography, access, and mobility.

Scientific assessment reports produced over the past decade by the U.S. Global Change Research Program (USGCRP), the IPCC, and the National Academies of Science, Engineering, and Medicine add more evidence that the impacts of climate change raise potential EJ concerns.⁸¹⁶

⁸¹⁵ See Document ID No. EPA-HQ-OAR-2021-0317-1566.

⁸¹⁶ IPCC. (2018). *Global Warming of 1.5 °C*. An IPCC Special Report on the impacts of global warming of 1.5 °C above pre-industrial levels and related global greenhouse gas emission pathways, in the context of strengthening the global response to the threat of climate change, sustainable development, and efforts to eradicate poverty (V. Masson-Delmotte, P. Zhai, H.-O. Pörtner, D. Roberts, J. Skea, P.R. Shukla, A. Pirani, W. Moufouma-Okia, C. Péan, R. Pidcock, S. Connors, J.B.R. Matthews, Y. Chen, X. Zhou, M.I. Gomis, E. Lonnoy, T. Maycock, a. M. Tignor, & T. Waterfield

⁸¹⁴ See Document ID No. EPA-HQ-OAR-2021-0317-0173.

These reports conclude that poorer or predominantly non-White communities can be especially vulnerable to climate change impacts because they tend to have limited adaptive capacities and are more dependent on climate-sensitive resources such as local water and food supplies, or have less access to social and information resources. Some communities of color, specifically populations defined jointly by ethnic/racial characteristics and geographic location, may be uniquely vulnerable to climate change health impacts in the U.S. In particular, the 2016 scientific assessment on the Impacts of Climate Change on Human Health found with high confidence that vulnerabilities are place- and time-specific, life stages and ages are linked to immediate and future health impacts, and social determinants of health are linked to greater extent and severity of climate change-related health impacts. The GHG emission reductions associated with this proposal would contribute to efforts to reduce the probability of severe impacts related to

Eds.); Oppenheimer, M., Campos, M., Warren, R., Birkmann, J., Luber, G., O'Neill, B., & Takahashi, K. (2014). Emergent risks and key vulnerabilities. In C.B. Field, V.R. Barros, D.J. Dokken, K.J. Mach, M.D. Mastrandrea, T.E. Bilir, M. Chatterjee, K.L. Ebi, Y.O. Estrada, R.C. Genova, B. Girma, E.S. Kissel, A.N. Levy, S. MacCracken, P.R. Mastrandrea, & L.L. White (Eds.), *Climate Change 2014: Impacts, Adaptation, and Vulnerability. Part A: Global and Sectoral Aspects. Contribution of Working Group II to the Fifth Assessment Report of the Intergovernmental Panel on Climate Change* (pp. 1039–1099). Cambridge, United Kingdom and New York, NY: Cambridge University Press; Porter, J.R., Xie, L., Challinor, A.J., Cochrane, K., Howden, M., Iqbal, M.M., & Lobell, D.B. (2014). Food security and food production systems. In C.B. Field, V.R. Barros, D.J. Dokken, K.J. Mach, M.D. Mastrandrea, T.E. Bilir, M. Chatterjee, K.L. Ebi, Y.O. Estrada, R.C. Genova, B. Girma, E.S. Kissel, A.N. Levy, S. MacCracken, P.R. Mastrandrea, & L.L. White (Eds.), *Climate Change 2014: Impacts, Adaptation, and Vulnerability. Part A: Global and Sectoral Aspects. Contribution of Working Group II to the Fifth Assessment Report of the Intergovernmental Panel on Climate Change* (pp. 485–533). Cambridge, United Kingdom and New York, NY: Cambridge University Press; Smith, K. R., Woodward, A., Campbell-Lendrum, D., Chadee, D. D., Honda, Y., Liu, Q., . . . Sauerborn, R. (2014). Human Health: Impacts, Adaptation, and Co-Benefits. In C.B. Field, V.R. Barros, D.J. Dokken, K.J. Mach, M.D. Mastrandrea, T.E. Bilir, M. Chatterjee, K.L. Ebi, Y.O. Estrada, R.C. Genova, B. Girma, E.S. Kissel, A.N. Levy, S. MacCracken, P.R. Mastrandrea, & L.L. White (Eds.), *Climate Change 2014: Impacts, Adaptation, and Vulnerability. Part A: Global and Sectoral Aspects. Contribution of Working Group II to the Fifth Assessment Report of the Intergovernmental Panel on Climate Change* (pp. 709–754). Cambridge, United Kingdom and New York, NY: Cambridge University Press; USGCRP. (2016). *The Impacts of Climate Change on Human Health in the United States: A Scientific Assessment*. Washington DC: U.S. Global Change Research Program. <https://dx.doi.org/10.7930/JOR49NQX>; USGCRP. (2018). *Impacts, Risks, and Adaptation in the United States: Fourth National Climate Assessment, Volume II*. Washington DC: U.S. Global Change Research Program. <https://dx.doi.org/10.7930/NCA4.2018>.

climate change. Individuals living in socially and economically disadvantaged communities, such as those living at or below the poverty line or who are experiencing homelessness or social isolation, are at greater risk of health effects from climate change. This is also true with respect to people at vulnerable life stages, specifically women who are pre- and perinatal, or are nursing; in utero fetuses; children at all stages of development; and the elderly. Per the Fourth National Climate Assessment (NCA4), “Climate change affects human health by altering exposures to heat waves, floods, droughts, and other extreme events; vector-, food- and waterborne infectious diseases; changes in the quality and safety of air, food, and water; and stresses to mental health and well-being.” Many health conditions such as cardiopulmonary or respiratory illness and other health impacts are associated with and exacerbated by an increase in GHGs and climate change outcomes, which is problematic as these diseases occur at higher rates within vulnerable communities. Importantly, negative public health outcomes include those that are physical in nature, as well as mental, emotional, social, and economic.

To this end, the scientific assessment literature, including the aforementioned reports, demonstrates that there are myriad ways in which these populations may be affected at the individual and community levels. Individuals face differential exposure to criteria pollutants, in part due to the proximities of highways, trains, factories, and other major sources of pollutant-emitting sources to less-affluent residential areas. Outdoor workers, such as construction or utility crews and agricultural laborers, who frequently are comprised of already at-risk groups, are exposed to poor air quality and extreme temperatures without relief. Furthermore, individuals within EJ populations of concern face greater housing, clean water, and food insecurity and bear disproportionate economic impacts and health burdens associated with climate change effects. They have less or limited access to healthcare and affordable, adequate health or homeowner insurance. Finally, resiliency and adaptation are more difficult for economically disadvantaged communities: They have less liquidity, individually and collectively, to move or to make the types of infrastructure or policy changes to limit or reduce the hazards they face. They frequently are less able to self-advocate for resources that would

otherwise aid in building resilience and hazard reduction and mitigation.

In a 2021 report, *Climate Change and Social Vulnerability in the United States: A Focus on Six Impacts*, the EPA considered the degree to which four socially vulnerable populations—defined based on income, educational attainment, race and ethnicity, and age—may be more exposed to the highest impacts of climate change.⁸¹⁷ The report found that Blacks and African American populations are approximately 40 percent more likely to currently live in these areas of the U.S. projected to experience the highest increases in mortality rates due to changes in temperature. Additionally, Hispanic and Latino individuals in weather exposed industries were found to be 43 percent more likely to currently live in areas with the highest projected labor hour losses due to temperature changes. American Indian and Alaska Native individuals are projected to be 48 percent more likely to currently live in areas where the highest percentage of land may be inundated by sea level rise. Overall, the report confirmed findings of broader climate science assessments that Americans identifying as people of color, those with low-income, and those without a high school diploma face higher differential risks of experiencing the most damaging impacts of climate change.

The assessment literature cited in the EPA’s 2009 and 2016 Endangerment and Cause or Contribute Findings, as well as Impacts of Climate Change on Human Health (2016) and the NCA4 (2018), also concluded that certain populations and life stages, including children, are especially sensitive to climate-related health effects. In a more recent 2023 report, *Climate Change Impacts on Children’s Health and Well-Being in the U.S.*, the EPA considered the degree to which children’s health and well-being may be impacted by five climate-related environmental hazards—extreme heat, poor air quality, changes in seasonality, flooding, and different types of infectious diseases.⁸¹⁸ The report found that children’s academic achievement is projected to be reduced by 4–7 percent per child, as a result of moderate and higher levels of warming, impacting future income levels. The report also projects increases in the numbers of

⁸¹⁷ U.S. EPA. (2021c) *Climate Change and Social Vulnerability in the United States: A Focus on Six Impacts* (EPA-430-R-21-003) Retrieved from Washington, DC: <https://epa.gov/cira/social-vulnerability-report>.

⁸¹⁸ U.S. EPA. (2023b). *Climate Change and Children’s Health and Wellbeing in the United States*. https://www.epa.gov/system/files/documents/2023-04/CLiME_Final%20Report.pdf.

annual emergency department visits associated with asthma, and that the number of new asthma diagnoses increases by 4–11% due to climate-driven increases in air pollution relative to current levels. In addition, more than 1 million children in coastal regions are projected to be temporarily displaced from their homes annually due to climate-driven flooding, and infectious disease rates are similarly anticipated to rise, with the number of new Lyme disease cases in children living in 22 states in the eastern and midwestern U.S. increasing by approximately 3,000–23,000 per year compared to current levels. Overall, the report confirmed findings of broader climate science assessments that children are uniquely vulnerable to climate-related impacts and that in many situations, children in the U.S. who identify as Black, Indigenous, and People of Color, are limited English-speaking, do not have health insurance, or live in low-income communities may be disproportionately exposed to the most severe impacts of climate change.

Native American Tribal communities possess unique vulnerabilities to climate change, particularly those impacted by degradation of natural and cultural resources within established reservation boundaries and threats to traditional subsistence lifestyles. Tribal communities whose health, economic well-being, and cultural traditions depend upon the natural environment will likely be affected by the degradation of ecosystem goods and services associated with climate change. The IPCC indicates that losses of customs and historical knowledge may cause communities to be less resilient or adaptable. The NCA4 noted that while Indigenous peoples are diverse and will be impacted by the climate changes universal to all Americans, there are several ways in which climate change uniquely threatens Indigenous peoples' livelihoods and economies. In addition, there can be institutional barriers to their management of water, land, and other natural resources that could impede adaptive measures.

For example, Indigenous agriculture in the Southwest is already being adversely affected by changing patterns of flooding, drought, dust storms, and rising temperatures leading to increased soil erosion, irrigation water demand, and decreased crop quality and herd sizes. The Confederated Tribes of the Umatilla Indian Reservation in the Northwest have identified climate risks to salmon, elk, deer, roots, and huckleberry habitat. Housing and sanitary water supply infrastructure are

vulnerable to disruption from extreme precipitation events.

NCA4 noted that Indigenous peoples often have disproportionately higher rates of asthma, cardiovascular disease, Alzheimer's, diabetes, and obesity, which can all contribute to increased vulnerability to climate-driven extreme heat and air pollution events. These factors also may be exacerbated by stressful situations, such as extreme weather events, wildfires, and other circumstances.

NCA4 and IPCC Fifth Assessment Report also highlighted several impacts specific to Alaskan Indigenous Peoples. Coastal erosion and permafrost thaw will lead to more coastal erosion, exacerbated risks of winter travel, and damage to buildings, roads, and other infrastructure—these impacts on archaeological sites, structures, and objects that will lead to a loss of cultural heritage for Alaska's Indigenous people. In terms of food security, the NCA4 discussed reductions in suitable ice conditions for hunting, warmer temperatures impairing the use of traditional ice cellars for food storage, and declining shellfish populations due to warming and acidification. While the NCA also noted that climate change provided more opportunity to hunt from boats later in the fall season or earlier in the spring, the assessment found that the net impact was an overall decrease in food security.

In addition, the U.S. Pacific Islands and the indigenous communities that live there are also uniquely vulnerable to the effects of climate change due to their remote location and geographic isolation. They rely on the land, ocean, and natural resources for their livelihoods, but face challenges in obtaining energy and food supplies that need to be shipped in at high costs. As a result, they face higher energy costs than the rest of the nation and depend on imported fossil fuels for electricity generation and diesel. These challenges exacerbate the climate impacts that the Pacific Islands are experiencing. NCA4 notes that Indigenous peoples of the Pacific are threatened by rising sea levels, diminishing freshwater availability, and negative effects to ecosystem services that threaten these individuals' health and well-being.

K. Congressional Review Act (CRA)

This action is subject to the CRA, and the EPA will submit the rule report to each House of the Congress and to the Comptroller General of the United States. This action meets the criteria set forth in 5 U.S.C. 804(2).

List of Subjects in 40 CFR Part 60

Environmental protection, Administrative practice and procedures, Air pollution control, Incorporation by reference, Reporting and recordkeeping requirements.

Michael S. Regan,
Administrator.

For the reasons stated in the preamble, the Environmental Protection Agency amends part 60 of title 40, chapter I, of the Code of Federal Regulations as follows:

PART 60—STANDARDS OF PERFORMANCE FOR NEW STATIONARY SOURCES

- 1. The authority citation for part 60 continues to read as follows:

Authority: 42 U.S.C. 4701, *et seq.*

Subpart A—General Provisions

- 2. Section 60.17 is amended by:
 - a. Revising paragraphs (a), (g) introductory text, (g)(14), and (h) introductory text;
 - b. Revising paragraphs (h)(19) and (h)(76);
 - c. Redesignating paragraphs(h)(213) through (223) as paragraphs (h)(218) through (228), paragraphs(h)(210) through (212) as paragraphs (h)(214) through (216), paragraphs (h)(197) through (209) as paragraphs (h)(200) through (212), paragraphs(h)(192) through (196) as paragraphs (h)(194) through (198), and paragraphs (h)(77) through (191) as paragraphs (h)(78) through (192), respectively;
 - d. Adding new paragraph (h)(77);
 - e. Revising newly redesignated paragraphs (h)(112), (113), (114), (142), and (h)(173);
 - f. Add new paragraphs (h)(193), (199), (213), and (217);
 - g. Revising newly redesignated paragraph (h)(220) and (j) introductory text;
 - j. Redesignating paragraphs (j)(2) through (j)(5) as paragraphs (j)(3) through (j)(6);
 - k. Adding new paragraph (j)(2); and
 - l. Revising the newly redesignated paragraph (j)(4).

The revisions and additions read as follows:

§ 60.17 Incorporations by reference.

(a) Certain material is incorporated by reference into this part with the approval of the Director of the Federal Register under 5 U.S.C. 552(a) and 1 CFR part 51. To enforce any edition other than that specified in this section, the EPA must publish notice of change in the **Federal Register** and the material

must be available to the public. All approved incorporation by reference (IBR) material is available for inspection at the EPA and at the National Archives and Records Administration (NARA). Contact the EPA at: EPA Docket Center, Public Reading Room, EPA WJC West, Room 3334, 1301 Constitution Ave. NW, Washington, DC, telephone: 202-566-1744. For information on the availability of this material at NARA, visit www.archives.gov/federal-register/cfr/ibr-locations.html or email fr.inspection@nara.gov. The material may be obtained from the sources in the following paragraphs of this section.

(g) American Society of Mechanical Engineers (ASME), Two Park Avenue, New York, NY 10016-5990; phone: (800) 843-2763; email: CustomerCare@asme.org; website: www.asme.org.

(14) ASME/ANSI PTC 19.10-1981, Flue and Exhaust Gas Analyses [Part 10, Instruments and Apparatus], Issued August 31, 1981; IBR approved for §§ 60.56c(b); 60.63(f); 60.106(e); 60.104a(d), (h), (i), and (j); 60.105a(b), (d), (f), and (g); 60.106a(a); 60.107a(a), (c), and (d); 60.275(e); 60.275a(e); 60.275b(e); tables 1 and 3 to subpart EEEE; tables 2 and 4 to subpart FFFF; table 2 to subpart JJJJ; §§ 60.285a(f); 60.396(a); 60.2145(s) and (t); 60.2710(s) and (t); 60.2730(q); 60.4415(a); 60.4900(b); 60.5220(b); tables 1 and 2 to subpart LLLL; tables 2 and 3 to subpart MMMM; §§ 60.5406(c); 60.5406a(c); 60.5406b(c); 60.5407a(g); 60.5407b(g); 60.5413(b); 60.5413a(b) and (d); 60.5413b(b) and (d); §§ 60.5413c(b) and (d).

(h) ASTM International, 100 Barr Harbor Drive, P.O. Box CB700, West Conshohocken, Pennsylvania 19428-2959; phone: (800) 262-1373; website: www.astm.org.

(19) ASTM D86-96, Distillation of Petroleum Products, approved April 10, 1996; IBR approved for §§ 60.562-2(d). 60.593(d). 60.593a(d); 60.633(h); 60.5401(f); 60.5401a(f); 60.5402b(d); 60.5402c(d).

(76) ASTM D1945-03 (Reapproved 2010), Standard Method for Analysis of Natural Gas by Gas Chromatography, approved January 1, 2010; IBR approved for §§ 60.107a(d); 60.5413(d); 60.5413a(d); 60.5413b(d); 60.5413c(d).

(77) ASTM D1945-14 (Reapproved 2019), Standard Test Method for Analysis of Natural Gas by Gas Chromatography, approved December 1,

2019; IBR approved for §§ 60.5417b(d); 60.5417c(d).

(112) ASTM D2879-83, Test Method for Vapor Pressure-Temperature Relationship and Initial Decomposition Temperature of Liquids by Isoteniscope, approved 1983; IBR approved for §§ 60.111b(f); 60.116b(e) and (f); 60.485(e); 60.485a(e); 60.5403b(d); 60.5406c(d).

(113) ASTM D2879-96, Test Method for Vapor Pressure-Temperature Relationship and Initial Decomposition Temperature of Liquids by Isoteniscope, approved 1996; IBR approved for §§ 60.111b(f); 60.116b(e) and (f); 60.485(e); 60.485a(e); 60.5403b(d); 60.5406c(d).

(114) ASTM D2879-97, Test Method for Vapor Pressure-Temperature Relationship and Initial Decomposition Temperature of Liquids by Isoteniscope, approved 1997; IBR approved for §§ 60.111b(f); 60.116b(e) and (f); 60.485(e); 60.485a(e); 60.5403b(d); 60.5406c(d).

(142) ASTM D3588-98 (Reapproved 2003), Standard Practice for Calculating Heat Value, Compressibility Factor, and Relative Density of Gaseous Fuels, approved May 10, 2003; IBR approved for §§ 60.107a(d); 60.5413(d); 60.5413a(d); 60.5413b(d); 60.5413c(d).

(173) ASTM D4891-89 (Reapproved 2006), Standard Test Method for Heating Value of Gases in Natural Gas Range by Stoichiometric Combustion, approved June 1, 2006; IBR approved for §§ 60.107a(d); 60.5413(d); 60.5413a(d); 60.5413b(d); 60.5413c(d).

(193) ASTM D6348-12e1, Standard Test Method for Determination of Gaseous Compounds by Extractive Direct Interface Fourier Transform Infrared (FTIR) Spectroscopy, approved February 1, 2012; IBR approved for § 60.5413c(b).

(199) ASTM D6522-20, Standard Test Method for Determination of Nitrogen Oxides, Carbon Monoxide, and Oxygen Concentrations in Emissions from Natural Gas-Fired Reciprocating Engines, Combustion Turbines, Boilers, and Process Heaters Using Portable Analyzers, approved June 1, 2020; IBR approved for §§ 60.5413b(b); 60.5413c(b).

(213) ASTM E168-16, (Reapproved 2023), Standard Practices for General Techniques of Infrared Quantitative Analysis, approved January 1, 2023; IBR

approved for §§ 60.5400b(a); 60.5400c(a); 60.5401b(a); 60.5401c(a).

(217) ASTM E169-16 (Reapproved 2022), Standard Practices for General Techniques of Ultraviolet-Visible Quantitative Analysis, approved November 1, 2022; IBR approved for §§ 60.5400b(a); 60.5400c; 60.5401b(a); 60.5401c(a).

(220) ASTM E260-96, General Gas Chromatography Procedures, approved April 10, 1996; IBR approved for §§ 60.485a(d), 60.593(b), 60.593a(b), 60.632(f), 60.5400(f), 60.5400a(f), 60.5406(b), 60.5406a(b)(3), 60.5400b(a)(2), 60.5401b(a)(2), 60.5406b(b)(3), 60.5400c(a), and 60.5401c(a).

(j) U.S. Environmental Protection Agency, 1200 Pennsylvania Avenue NW, Washington, DC 20460; phone: (202) 272-0167; website: www.epa.gov.

(2) EPA-454/B-08-002, Quality Assurance Handbook for Air Pollution Measurement Systems; Volume IV: Meteorological Measurements, Version 2.0 (Final), March 2008; IBR approved for Appendix K to this part.

(4) EPA-600/R-12/531, EPA Traceability Protocol for Assay and Certification of Gaseous Calibration Standards, Issued May 2012; IBR approved for §§ 60.5413(d); 60.5413a(d); 60.5413b(d); 60.5413c(d).

Subpart KKK—Standards of Performance for Equipment Leaks of VOC From Onshore Natural Gas Processing Plants for Which Construction, Reconstruction, or Modification Commenced After January 20, 1984, and on or Before August 23, 2011

■ 3. Section 60.630 is amended by adding paragraph (f) to read as follows:

§ 60.630 Applicability and designation of affected facility.

(f) An affected facility must continue to comply with the requirements of this subpart until it begins complying with a more stringent requirement, that applies to the same affected facility, in an approved, and effective, State or Federal plan that implements subpart OOOOc of this part, or modifies or reconstructs after December 6, 2022, and thus becomes subject to subpart OOOOb of this part.

Subpart OOOO—Standards of Performance for Crude Oil and Natural Gas Facilities for Which Construction, Modification, or Reconstruction Commenced After August 23, 2011, and on or Before September 18, 2015

■ 4. Section 60.5360 is revised to read as follows:

§ 60.5360 What is the purpose of this subpart?

This subpart establishes emission standards and compliance schedules for the control of volatile organic compounds (VOC) and sulfur dioxide (SO₂) emissions from affected facilities that commence construction, modification, or reconstruction after August 23, 2011, and on or before September 18, 2015.

■ 5. Amend § 60.5365 by:

■ a. Revising the introductory text, and paragraphs (b), (c), and (d)(1);

■ b. Adding paragraph (d)(2); and

■ c. Revising the introductory text of paragraph (e).

The revisions and addition read as follows:

§ 60.5365 Am I subject to this subpart?

You are subject to the applicable provisions of this subpart if you are the owner or operator of one or more of the onshore affected facilities listed in paragraphs (a) through (g) of this section for which you commence construction, modification, or reconstruction after August 23, 2011, and on or before September 18, 2015. An affected facility must continue to comply with the requirements of this subpart until it begins complying with a more stringent requirement, that applies to the same affected facility, in an approved, and effective, state or Federal plan that implements subpart OOOOc of this part, or modifies or reconstructs after December 6, 2022, and thus becomes subject to subpart OOOOb of this part.

* * * * *

(b) Each centrifugal compressor affected facility, which is a single centrifugal compressor using wet seals that is located between the wellhead and the point of custody transfer to the natural gas transmission and storage segment. A centrifugal compressor located at a well site, or an adjacent well site and servicing more than one well site, is not an affected facility under this subpart.

(c) Each reciprocating compressor affected facility, which is a single reciprocating compressor located between the wellhead and the point of custody transfer to the natural gas transmission and storage segment. A reciprocating compressor located at a

well site, or an adjacent well site and servicing more than one well site, is not an affected facility under this subpart.

(d)(1) For the oil production segment (between the wellhead and the point of custody transfer to an oil pipeline), each pneumatic controller affected facility, which is a single continuous bleed natural gas-driven pneumatic controller operating at a natural gas bleed rate greater than 6 standard cubic feet per hour.

(2) For the natural gas production segment (between the wellhead and the point of custody transfer to the natural gas transmission and storage segment and not including natural gas processing plants), each pneumatic controller affected facility, which is a single continuous bleed natural gas-driven pneumatic controller operating at a natural gas bleed rate greater than 6 standard cubic feet per hour.

* * * * *

(e) Each storage vessel affected facility, which is a single storage vessel located in the oil and natural gas production segment, natural gas processing segment or natural gas transmission and storage segment, and has the potential for VOC emissions equal to or greater than 6 tons per year (tpy) as determined according to this section by October 15, 2013, for Group 1 storage vessels and by April 15, 2014, or 30 days after startup (whichever is later) for Group 2 storage vessels, except as provided in paragraphs (e)(1) through (4) of this section. The potential for VOC emissions must be calculated using a generally accepted model or calculation methodology, based on the maximum average daily throughput determined for a 30-day period of production prior to the applicable emission determination deadline specified in this section. The determination may take into account requirements under a legally and practically enforceable limit in an operating permit or other requirement established under a Federal, State, local or Tribal authority.

* * * * *

■ 6. Add § 60.5371 to read as follows:

§ 60.5371 What standards apply to super-emitter events?

This section applies to super-emitter events. For purposes of this section, a super-emitter event is defined as any emissions event that is located at an individual well site or compressor station and that is detected using remote detection methods and has a quantified emission rate of 100 kg/hr of methane or greater. Upon receiving a notification of a super emitter event issued by the EPA under § 60.5371b(c), owners or

operators must take the actions listed in paragraphs (a) and (b) of this section. Within 5 calendar days of receiving a notification from the EPA of a super-emitter event, the owner or operator of an oil and natural gas facility (e.g., a well site, centralized production facility, natural gas processing plant, or compressor station) must initiate a super-emitter event investigation.

(a) *Identification of super-emitter events.* (1) If you do not own or operate an oil and natural gas facility within 50 meters from the latitude and longitude provided in the notification subject to the regulation under this subpart, report this result to the EPA under paragraph (e) of this section. Your super-emitter event investigation is deemed complete under this subpart.

(2) If you own or operate an oil and natural gas facility within 50 meters from the latitude and longitude provided in the notification subject to regulation under this subpart, you must investigate to determine the source of super-emitter event. The investigation may include but is not limited to the actions specified below in paragraphs (a)(2)(i) through (iii) of this section.

(i) Review any maintenance activities or process activities from the affected facilities subject to regulation under this subpart, starting from the date of detection of the super-emitter event as identified in the notification, until the date of investigation, to determine if the activities indicate any potential source(s) of the super-emitter event emissions.

(ii) Review all monitoring data from control devices (e.g., flares) from the affected facilities subject to regulation under this subpart from the initial date of detection of the super-emitter event as identified in the notification, until the date of receiving the notification from the EPA to identify malfunctions of control devices or periods when the control devices were not in compliance with applicable requirements and that indicate a potential source of the super-emitter event emissions.

(iii) Screen the entire well site or compressor station with OGI, or Method 21 of appendix A-7 to this part, or an alternative test method(s) approved per § 60.5398b(d), to determine if a super-emitter event is present.

(b) *Super-emitter event report.* For equipment subject to regulation under this subpart, you must submit the results of the super-emitter event investigation conducted under paragraph (a) of this section to the EPA in accordance with paragraph (b)(1) of this section. If the super-emitter event (i.e., emission at 100 kg/hr of methane or more) is ongoing at the time of the

initial report, submit the additional information in accordance with paragraph (b)(2) of this section. You must attest to the information included in the report as specified in paragraph (b)(3) of this section.

(1) Within 15 days of receiving a notification from the EPA under § 60.5371b(c), you must submit a report of the super-emitter event investigation conducted under paragraph (a) of this section through the Super-Emitter Program Portal. You must include the applicable information in paragraphs (b)(1)(i) through (viii) of this section in the report. If you have identified a demonstrable error in the notification, the report may include a statement of the demonstrable error.

(i) Notification Report ID of the super-emitter event notification.

(ii) Identification of whether you are the owner or operator of an oil and natural gas facility within 50 meters from the latitude and longitude provided in the EPA notification. If you do not own or operate an oil and natural gas facility within 50 meters from the latitude and longitude provided in the EPA notification, you are not required to report the information in paragraphs (b)(1)(iii) through (viii) of this section.

(iii) General identification information for the facility, including, facility name, the physical address, applicable ID Number (e.g., EPA ID Number, API Well ID Number), the owner or operator or responsible official (where applicable) and their email address.

(iv) Identification of whether there is an affected facility or associated equipment subject to regulation under this subpart at a well site or compressor station you own or operate within 50 meters from the latitude and longitude provided in the EPA notification.

(v) Indication of whether you were able to identify the source of the super-emitter event. If you indicate you were unable to identify the source of the super-emitter event, you must certify that all applicable investigations specified in paragraphs (d)(6)(i) through (v) of this section have been conducted for all affected facilities and associated equipment subject to this subpart that are at this oil and natural gas facility, and you have determined that the affected facilities and associated equipment are not the source of the super-emitter event. If you indicate that you were not able to identify the source of the super-emitter event, you are not required to report the information in paragraphs (b)(1)(vi) through (viii) of this section.

(vi) The source(s) of the super-emitter event.

(vii) Identification of whether the source of the super-emitter event is an affected facility or associated equipment subject to regulation under of this subpart. If the source of the super-emitter event is equipment subject to regulation under this subpart, identify the applicable regulation(s) under this subpart.

(viii) Indication of whether the super-emitter event is ongoing at the time of the initial report submittal (i.e., emission at 100 kg/hr of methane or more).

(A) If the super-emitter event is not ongoing at the time of the initial report submittal, provide the estimated date and time the super-emitter event ended.

(B) If the super-emitter event is ongoing at the time of the initial report submittal, provide a short narrative of your plan to end the super-emitter event, including the targeted end date for the efforts to be completed and the super-emitter event ended.

(2) If the super-emitter event is ongoing at the time of the initial report submittal, within 5 business days of the date the super-emitter event ends, you must update your initial report through the Super-Emitter Program Portal (available at <http://www.epa.gov/super-emitter>) to provide the end date and time of the super-emitter event.

(3) You must sign the following attestation must be signed by the owner or operator into when submitting data into the Super-Emitter Program Portal: "I certify that the information provided in this report regarding the specified super-emitter event was prepared under my direction or supervision. I further certify that the investigations were conducted, and this report was prepared pursuant to the requirements of § 60.5371(a) and (b). Based on my professional knowledge and experience, and inquiry of personnel involved in the assessment, the certification submitted herein is true, accurate, and complete. I am aware that knowingly false statements may be punishable by fine or imprisonment."

■ 7. Amend § 60.5420 by revising paragraph (c)(5)(iv) to read as follows:

§ 60.5420 What are my notification, reporting, and recordkeeping requirements?

* * * * *

(c) * * *

(5) * * *

(iv) For storage vessels that are skid-mounted or permanently attached to something that is mobile (such as trucks, railcars, barges, or ships), records indicating the number of consecutive days that the vessel is located at a site in the oil and natural

gas production segment, natural gas processing segment or natural gas transmission and storage segment. If a storage vessel is removed from a site and, within 30 days, is either returned to or replaced by another storage vessel at the site to serve the same or similar function, then the entire period since the original storage vessel was first located at the site, including the days when the storage vessel was removed, will be added to the count towards the number of consecutive days.

* * * * *

■ 8. Amend § 60.5430 by:

■ a. Removing the definition for "Crude Oil and Natural Gas Production source category";

■ b. Revising the definition for "Custody transfer"; and

■ c. Removing the definition for "Local distribution company (LDC) custody transfer station" and "Natural gas transmission and storage segment".

The revision reads as follows:

§ 60.5430 What definitions apply to this subpart?

* * * * *

Custody transfer means the transfer of natural gas after processing and/or treatment in the producing operations, or from storage vessels or automatic transfer facilities or other such equipment, including product loading racks, to pipelines or any other forms of transportation.

* * * * *

Subpart OOOOa—Standards of Performance for Crude Oil and Natural Gas Facilities for Which Construction, Modification or Reconstruction Commenced After September 18, 2015 and On or Before December 6, 2022

■ 9. Revise the subpart heading of subpart OOOOa to read as set forth above.

■ 10. Revise § 60.5360a to read as follows:

§ 60.5360a What is the purpose of this subpart?

(a) *Scope*. This subpart establishes emission standards and compliance schedules for the control of the pollutant greenhouse gases (GHG). The greenhouse gas standard in this subpart is in the form of a limitation on emissions of methane from affected facilities in the crude oil and natural gas source category that commence construction, modification, or reconstruction after September 18, 2015. This subpart also establishes emission standards and compliance schedules for the control of volatile organic compounds (VOC) and sulfur dioxide

(SO₂) emissions from affected facilities in the crude oil and natural gas source category that commence construction, modification, or reconstruction after September 18, 2015, and on or before December 6, 2022.

(b) *Prevention of Significant Deterioration (PSD) and title V thresholds for Greenhouse Gases.* (1) For the purposes of 40 CFR 51.166(b)(49)(ii), with respect to GHG emissions from affected facilities, the “pollutant that is subject to the standard promulgated under section 111 of the Act” shall be considered to be the pollutant that otherwise is subject to regulation under the Act as defined in 40 CFR 51.166(b)(48) and in any State Implementation Plan (SIP) approved by the EPA that is interpreted to incorporate, or specifically incorporates, 40 CFR 51.166(b)(48).

(2) For the purposes of 40 CFR 52.21(b)(50)(ii), with respect to GHG emissions from affected facilities, the “pollutant that is subject to the standard promulgated under section 111 of the Act” shall be considered to be the pollutant that otherwise is subject to regulation under the Clean Air Act as defined in 40 CFR 52.21(b)(49).

(3) For the purposes of 40 CFR 70.2, with respect to greenhouse gas emissions from affected facilities, the “pollutant that is subject to any standard promulgated under section 111 of the Act” shall be considered to be the pollutant that otherwise is “subject to regulation” as defined in 40 CFR 70.2.

(4) For the purposes of 40 CFR 71.2, with respect to greenhouse gas emissions from affected facilities, the “pollutant that is subject to any standard promulgated under section 111 of the Act” shall be considered to be the pollutant that otherwise is “subject to regulation” as defined in 40 CFR 71.2.

■ 11. Amend § 60.5365a by revising the introductory text and paragraph (a)(4) to read as follows:

§ 60.5365a Am I subject to this subpart?

You are subject to the applicable provisions of this subpart if you are the owner or operator of one or more of the onshore affected facilities listed in paragraphs (a) through (j) of this section, that is located within the Crude Oil and Natural Gas source category, as defined in § 60.5430a, for which you commence construction, modification, or reconstruction after September 18, 2015, and on or before December 6, 2022. Facilities located inside and including the Local Distribution Company (LDC) custody transfer station are not subject to this subpart. An affected facility must continue to comply with the requirements of this subpart until it

begins complying with a more stringent requirement, that applies to the same affected facility, in an approved, and effective, state or Federal plan that implements subpart OOOOc of this part, or modifies or reconstructs after December 6, 2022, and thus becomes subject to subpart OOOOb of this part.

(a) * * *

(4) A well initially constructed after September 18, 2015, and on or before December 6, 2022, that conducts a well completion operation following hydraulic fracturing is considered an affected facility regardless of this provision.

* * * * *

■ 12. Add § 60.5371a to read as follows:

§ 60.5371a What standards apply to super-emitter events?

This section applies to super-emitter events. For purposes of this section, a super-emitter event is defined as any emissions event that is located at or near an oil and gas facility (e.g., individual well site, natural gas processing plant or compressor station) and that is detected using remote detection methods and has a quantified emission rate of 100 kg/hr of methane or greater. Upon receiving a notification of a super emitter event issued by the EPA under § 60.5371b(c) in subpart OOOOb of this part, owners or operators must take the actions listed in paragraphs (a) and (b) of this section. Within 5 calendar days of receiving a notification from the EPA of a super-emitter event, the owner or operator of an oil and natural gas facility (e.g., a well site, centralized production facility, natural gas processing plant, or compressor station) must initiate a super-emitter event investigation.

(a) *Identification of super-emitter events.* (1) If you do not own or operate an oil and natural gas facility within 50 meters from the latitude and longitude provided in the notification subject to the regulation under this subpart, report this result to the EPA under paragraph (e) of this section. Your super-emitter event investigation is deemed complete under this subpart.

(2) If you own or operate an oil and natural gas facility within 50 meters from the latitude and longitude provided in the notification, and there is an affected facility or associated equipment subject to this subpart onsite, you must investigate to determine the source of the super-emitter event in accordance with paragraph (a)(2) of this section, maintain records of your investigation, and report the results in accordance with paragraph (b) of this section.

(3) The investigation required by paragraph (a)(2) of this section may

include but is not limited to the actions specified below in paragraphs (a)(3)(i) through (iv) of this section.

(i) Review any maintenance activities or process activities from the affected facilities subject to regulation under this subpart, starting from the date of detection of the super-emitter event as identified in the notification, until the date of investigation, to determine if the activities indicate any potential source(s) of the super-emitter event emissions.

(ii) Review all monitoring data from control devices (e.g., flares) from the affected facilities subject to regulation under this subpart from the initial date of detection of the super-emitter event as identified in the notification, until the date of receiving the notification from the EPA to identify malfunctions of control devices or periods when the control devices were not in compliance with applicable requirements and that indicate a potential source of the super-emitter event emissions.

(iii) If you conducted a fugitive emissions survey in accordance with § 60.5397a between the initial date of detection of the super-emitter event as identified in the notification and the date the notification from the EPA was received, review the results of the survey to identify any potential source(s) of the super-emitter event emissions.

(iv) Screen the entire facility with OGI, Method 21 of appendix A–7 to this part, or an alternative test method(s) approved per § 60.5398b(d) of subpart OOOOb of this part, to determine if a super-emitter event is present.

(b) *Super-emitter event report.* You must submit the results of the super-emitter event investigation conducted under paragraph (a) of this section to the EPA in accordance with paragraph (b)(1) of this section. If the super-emitter event (i.e., emission at 100 kg/hr of methane or more) is ongoing at the time of this initial report, submit the additional information in accordance with paragraph (b)(2) of this section. You must attest to the information included in the report as specified in paragraph (b)(3) of this section.

(1) Within 15 days of receiving a notification from the EPA under § 60.5371b(c), you must submit a report of the super-emitter event investigation conducted under paragraph (a) of this section through the Super-Emitter Program Portal, at www.epa.gov/super-emitter. You must include the applicable information in paragraphs (b)(1)(i) through (viii) of this section in the report. If you have identified a demonstrable error in the notification,

the report may include a statement of the demonstrable error.

(i) Notification Report ID of the super-emitter event notification (which is provided in the EPA notification).

(ii) Identification of whether you are the owner or operator of an oil and natural gas facility within 50 meters from the latitude and longitude provided in the EPA notification. If you do not own or operate an oil and natural gas facility within 50 meters from the latitude and longitude provided in the EPA notification, you are not required to report the information in paragraphs (b)(1)(iii) through (viii) of this section.

(iii) General identification information for the facility, including facility name, the physical address, applicable ID Number (e.g., EPA ID Number, API Well ID Number), the owner or operator or responsible official (where applicable), and their email address.

(iv) Identification of whether there is an affected facility or associated equipment subject to regulation under this subpart at this oil and natural gas facility.

(v) Indication of whether you were able to identify the source of the super-emitter event. If you indicate you were unable to identify the source of the super-emitter event, you must certify that all applicable investigations specified in paragraphs (a)(2)(i) through (iv) of this section have been conducted for all affected facilities and associated equipment subject to regulation under this subpart that are at this oil and natural gas facility, and you have determined that these affected facilities and associated equipment are not the source of the super-emitter event. If you indicate that you were not able to identify the source of the super-emitter event, you are not required to report the information in paragraphs (b)(1)(vi) through (viii) of this section.

(vi) The source(s) of the super-emitter event.

(vii) Identification of whether the source of the super-emitter event is an affected facility or associated equipment subject to regulation under of this subpart. If the source of the super-emitter event is an affected facility or associated equipment subject to regulation under this subpart, identify the applicable regulation(s) under this subpart.

(viii) Indication of whether the super-emitter event is ongoing at the time of the initial report submittal (i.e., emissions at 100 kg/hr of methane or more).

(A) If the super-emitter event is not ongoing at the time of the initial report submittal, provide the actual (or if not

known, estimated) date and time the super-emitter event ended.

(B) If the super-emitter event is ongoing at the time of the initial report submittal, provide a short narrative of your plan to end the super-emitter event, including the targeted end date for the efforts to be completed and the super-emitter event ended.

(2) If the super-emitter event is ongoing at the time of the initial report submittal, within 5 business days of the date the super-emitter event ends you must update your initial report through the Super-Emitter Program Portal, to provide the end date and time of the super-emitter event.

(3) You must sign the following attestation when submitting data into the Super-Emitter Program Portal: "I certify that the information provided in this report regarding the specified super-emitter event was prepared under my direction or supervision. I further certify that the investigations were conducted, and this report was prepared pursuant to the requirements of § 60.5371a(a) and (b). Based on my professional knowledge and experience, and inquiry of personnel involved in the assessment, the certification submitted herein is true, accurate, and complete. I am aware that knowingly false statements may be punishable by fine or imprisonment."

■ 13. Amend § 60.5375a by revising the section heading and the introductory text to read as follows:

§ 60.5375a What GHG and VOC standards apply to well affected facilities?

If you are the owner or operator of a well affected facility as described in § 60.5365a(a) that also meets the criteria for a well affected facility in § 60.5365(a) (in subpart OOOO of this part), you must reduce GHG (in the form of a limitation on emissions of methane) and VOC emissions by complying with paragraphs (a) through (g) of this section. If you own or operate a well affected facility as described in § 60.5365a(a) that does not meet the criteria for a well affected facility in § 60.5365(a) (in subpart OOOO of this part), you must reduce GHG and VOC emissions by complying with paragraphs (f)(3) and (4) or paragraph (g) of this section for each well completion operation with hydraulic fracturing prior to November 30, 2016, and you must comply with paragraphs (a) through (g) of this section for each well completion operation with hydraulic fracturing on or after November 30, 2016.

* * * * *

■ 14. Amend § 60.5380a by revising the section heading, introductory text, and paragraph (a)(1) to read as follows:

§ 60.5380a What GHG and VOC standards apply to centrifugal compressor affected facilities?

You must comply with the GHG and VOC standards in paragraphs (a) through (d) of this section for each centrifugal compressor affected facility.

(a)(1) You must reduce methane and VOC emissions from each centrifugal compressor wet seal fluid degassing system by 95.0 percent.

* * * * *

■ 15. Amend § 60.5385a by revising the section heading, introductory text, and paragraph (a)(3) to read as follows:

§ 60.5385a What GHG and VOC standards apply to reciprocating compressor affected facilities?

You must reduce GHG (in the form of a limitation on emissions of methane) and VOC emissions by complying with the standards in paragraphs (a) through (d) of this section for each reciprocating compressor affected facility.

(a) * * *

(3) Collect the methane and VOC emissions from the rod packing using a rod packing emissions collection system that operates under negative pressure and route the rod packing emissions to a process through a closed vent system that meets the requirements of § 60.5411a(a) and (d).

* * * * *

■ 16. Amend § 60.5390a by revising the section heading and introductory text to read as follows:

§ 60.5390a What GHG and VOC standards apply to pneumatic controller affected facilities?

For each pneumatic controller affected facility you must comply with the GHG and VOC standards, based on natural gas as a surrogate for GHG and VOC, in either paragraph (b)(1) or (c)(1) of this section, as applicable. Pneumatic controllers meeting the conditions in paragraph (a) of this section are exempt from the requirements in paragraph (b)(1) or (c)(1) of this section.

* * * * *

■ 17. Amend § 60.5393a by revising the section heading and introductory text to read as follows:

§ 60.5393a What GHG and VOC standards apply to pneumatic pump affected facilities?

For each pneumatic pump affected facility you must comply with the GHG and VOC standards, based on natural gas as a surrogate for GHG and VOC, in either paragraph (a) or (b) of this

section, as applicable, on or after November 30, 2016.

* * * * *

■ 18. Amend § 60.5397a by:

- a. Revising the section heading, introductory text, and paragraph (a);
- b. Revising the introductory text of paragraph (g) and paragraph (g)(2);
- c. Adding paragraph (g)(6); and
- d. Revising paragraph (h)(3).

The revisions and addition read as follows:

§ 60.5397a What fugitive emissions GHG and VOC standards apply to the affected facility which is the collection of fugitive emissions components at a well site and the affected facility which is the collection of fugitive emissions components at a compressor station?

For each affected facility under § 60.5365a(i) and (j), you must reduce GHG (in the form of a limitation on emissions of methane) and VOC emissions by complying with the requirements of paragraphs (a) through (j) of this section. The requirements in this section are independent of the closed vent system and cover requirements in § 60.5411a. Alternatively, you may comply with the requirements of § 60.5398b, including the notification, recordkeeping, and reporting requirements outlined in § 60.5424b. For the purpose of this subpart, compliance with the requirements in § 60.5398b will be deemed compliance with this section. When complying with § 60.5398b, the definitions in § 60.5430b shall apply for those activities conducted under § 60.5398b.

(a) You must monitor all fugitive emission components, as defined in § 60.5430a, in accordance with paragraphs (b) through (g) of this section. You must repair all sources of fugitive emissions in accordance with paragraph (h) of this section. You must keep records in accordance with paragraph (i) of this section and report in accordance with paragraph (j) of this section. For purposes of this section, fugitive emissions are defined as any visible emission from a fugitive emissions component observed using optical gas imaging or an instrument reading of 500 parts per million (ppm) or greater using Method 21 of appendix A-7 to this part.

* * * * *

(g) A monitoring survey of each collection of fugitive emissions components at a well site or at a compressor station must be performed at the frequencies specified in paragraphs (g)(1) and (2) of this section,

with the exceptions noted in paragraphs (g)(3) through (6) of this section.

* * * * *

(2) Except as provided in this paragraph (g)(2), a monitoring survey of the collection of fugitive emissions components at a compressor station must be conducted at least quarterly after the initial survey. Consecutive quarterly monitoring surveys must be conducted at least 60 days apart. A monitoring survey of the collection of fugitive emissions components at a compressor station located on the Alaskan North Slope must be conducted at least annually. Consecutive annual monitoring surveys must be conducted at least 9 months apart and no more than 13 months apart.

* * * * *

(6) The requirements of paragraph (g)(2) of this section are waived for any collection of fugitive emissions components at a compressor station located within an area that has an average calendar month temperature below 0 °F for two of three consecutive calendar months of a quarterly monitoring period. The calendar month temperature average for each month within the quarterly monitoring period must be determined using historical monthly average temperatures over the previous three years as reported by a National Oceanic and Atmospheric Administration source or other source approved by the Administrator. The requirements of paragraph (g)(2) of this section shall not be waived for two consecutive quarterly monitoring periods.

(h) * * *

(3) Delay of repair will be allowed if the conditions in paragraphs (h)(3)(i) or (ii) of this section are met.

(i) If the repair is technically infeasible, would require a vent blowdown, a compressor station shutdown, a well shutdown or well shut-in, or would be unsafe to repair during operation of the unit, the repair must be completed during the next scheduled compressor station shutdown for maintenance, scheduled well shutdown, scheduled well shut-in, after a scheduled vent blowdown, or within 2 years of detecting the fugitive emissions, whichever is earliest. For purposes of this paragraph (h)(3), a vent blowdown is the opening of one or more blowdown valves to depressurize major production and processing equipment, other than a storage vessel.

(ii) If the repair requires replacement of a fugitive emissions component or a part thereof, but the replacement cannot be acquired and installed within the repair timelines specified in paragraphs

(h)(1) and (2) of this section due to either of the conditions specified in paragraphs (h)(3)(ii)(A) or (B) of this section, the repair must be completed in accordance with paragraph (h)(3)(ii)(C) of this section and documented in accordance with § 60.5420a(c)(15)(vii)(I).

(A) Valve assembly supplies had been sufficiently stocked but are depleted at the time of the required repair.

(B) A replacement fugitive emissions component or a part thereof requires custom fabrication.

(C) The required replacement must be ordered no later than 10 calendar days after the first attempt at repair. The repair must be completed as soon as practicable, but no later than 30 calendar days after receipt of the replacement component, unless the repair requires a compressor station or well shutdown. If the repair requires a compressor station or well shutdown, the repair must be completed in accordance with the timeframe specified in paragraph (h)(3)(i) of this section.

* * * * *

■ 19. Amend § 60.5398a by revising the section heading and paragraph (a) to read as follows:

§ 60.5398a What are the alternative means of emission limitations for GHG and VOC from well completions, reciprocating compressors, the collection of fugitive emissions components at a well site and the collection of fugitive emissions components at a compressor station?

(a) If, in the Administrator's judgment, an alternative means of emission limitation will achieve a reduction in GHG (in the form of a limitation on emissions of methane) and VOC emissions at least equivalent to the reduction in GHG and VOC emissions achieved under § 60.5375a, § 60.5385a, or § 60.5397a, the Administrator will publish, in the **Federal Register**, a document permitting the use of that alternative means for the purpose of compliance with § 60.5375a, § 60.5385a, or § 60.5397a. The authority to approve an alternative means of emission limitation is retained by the Administrator and shall not be delegated to States under section 111(c) of the Clean Air Act (CAA).

* * * * *

■ 20. Amend § 60.5399a by revising paragraphs (a), (f), (i), and (m) to read as follows:

§ 60.5399a What alternative fugitive emissions standards apply to the affected facility which is the collection of fugitive emissions components at a well site and the affected facility which is the collection of fugitive emissions components at a compressor station: Equivalency with state, local, and Tribal programs?

* * * * *

(a) *Alternative fugitive emissions standards.* If, in the Administrator’s judgment, an alternative fugitive emissions standard will achieve a reduction in methane and VOC emissions at least equivalent to the reductions achieved under § 60.5397a, the Administrator will publish, in the **Federal Register**, a notice permitting use of the alternative fugitive emissions standard for the purpose of compliance with § 60.5397a. The authority to approve alternative fugitive emissions standards is retained by the Administrator and shall not be delegated to States under section 111(c) of the CAA.

* * * * *

(f) *Alternative fugitive emissions requirements for the collection of fugitive emissions components located at a well site or a compressor station in the State of California.* An affected facility, which is the collection of fugitive emissions components, as defined in § 60.5430a, located at a well site or a compressor station in the State of California may elect to comply with the monitoring, repair, and recordkeeping requirements in the California Code of Regulations, title 17, sections 95665–95667, effective January 1, 2020, as an alternative to complying with the requirements in § 60.5397a(f)(1) and (2), (g)(1) through (4), (h), and (i). The information specified in § 60.5420a(b)(7)(iii)(A) and the information specified in either § 60.5420a(b)(7)(iii)(B) or (C) may be provided as an alternative to the requirements in § 60.5397a(j).

* * * * *

(i) *Alternative fugitive emissions requirements for the collection of fugitive emissions components located at a compressor station in the State of Ohio.* An affected facility, which is the collection of fugitive emissions components, as defined in § 60.5430a, located at a compressor station in the State of Ohio may elect to comply with the monitoring, repair, and recordkeeping requirements in Ohio General Permit 18.1, effective February 7, 2017, as an alternative to complying with the requirements in § 60.5397a(f)(2), (g)(2) through (4), (h), and (i), provided the monitoring instrument used is optical gas imaging or a Method 21 instrument (see

appendix A–7 to this part) with a leak definition and reading of 500 ppm or greater. Monitoring must be conducted on at least a quarterly basis and skip periods cannot be applied. The information specified in § 60.5420a(b)(7)(iii)(A) and the information specified in either § 60.5420a(b)(7)(iii)(B) or (C) may be provided as an alternative to the requirements in § 60.5397a(j).

* * * * *

(m) *Alternative fugitive emissions requirements for the collection of fugitive emissions components located at a compressor station in the State of Texas.* An affected facility, which is the collection of fugitive emissions components, as defined in § 60.5430a, located at a compressor in the State of Texas may elect to comply with the monitoring, repair, and recordkeeping requirements in the Air Quality Standard Permit for Oil and Gas Handling and Production Facilities, section I(6), effective November 8, 2012, or at 30 Texas Administrative Code section 116.620, effective September 4, 2000, as an alternative to complying with the requirements in § 60.5397a(f)(2), (g)(2) through (4), (h), and (i), provided the monitoring instrument used is optical gas imaging or a Method 21 instrument (see appendix A–7 to this part) with a leak definition and reading of 500 ppm or greater. Monitoring must be conducted on at least a quarterly basis and skip periods may not be applied. If using the alternative in this paragraph (m), the information specified in § 60.5420a(b)(7)(iii)(A) and (C) must be provided in lieu of the requirements in § 60.5397a(j).

* * * * *

■ 21. Amend § 60.5400a by revising the section heading and paragraph (c) to read as follows:

§ 60.5400a What equipment leak GHG and VOC standards apply to affected facilities at an onshore natural gas processing plant?

* * * * *

(c) You may apply to the Administrator for permission to use an alternative means of emission limitation that achieves a reduction in emissions of methane and VOC at least equivalent to that achieved by the controls required in this subpart according to the requirements of § 60.5402a.

* * * * *

§ 60.5401a What are the exceptions to the equipment leak GHG and VOC standards for affected facilities at onshore natural gas processing plants?

■ 22. Amend § 60.5401a by revising the section heading to read as set forth above.

■ 23. Amend § 60.5402a by revising the section heading, paragraph (a), and paragraph (d)(2) introductory text to read as follows:

§ 60.5402a What are the alternative means of emission limitations for GHG and VOC equipment leaks on onshore natural gas processing plants?

(a) If, in the Administrator’s judgment, an alternative means of emission limitation will achieve a reduction in GHG and VOC emissions at least equivalent to the reduction in GHG and VOC emissions achieved under any design, equipment, work practice or operational standard, the Administrator will publish, in the **Federal Register**, a document permitting the use of that alternative means for the purpose of compliance with that standard. The document may condition permission on requirements related to the operation and maintenance of the alternative means.

* * * * *

(d) * * *

(2) The application must include operation, maintenance, and other provisions necessary to assure reduction in methane and VOC emissions at least equivalent to the reduction in methane and VOC emissions achieved under the design, equipment, work practice or operational standard in paragraph (a) of this section by including the information specified in paragraphs (d)(2)(i) through (x) of this section.

* * * * *

■ 24. Amend § 60.5410a by:
■ a. Revising paragraphs (a) introductory text, (b)(1), (d) introductory text, and (f); and

■ b. Removing paragraph (k).

The revisions read as follows:

§ 60.5410a How do I demonstrate initial compliance with the standards for my well, centrifugal compressor, reciprocating compressor, pneumatic controller, pneumatic pump, storage vessel, collection of fugitive emissions components at a well site, collection of fugitive emissions components at a compressor station, and equipment leaks at onshore natural gas processing plants and sweetening unit affected facilities?

* * * * *

(a) To achieve initial compliance with the methane and VOC standards for each well completion operation conducted at your well affected facility

you must comply with paragraphs (a)(1) through (4) of this section.

* * * * *

(b)(1) To achieve initial compliance with standards for your centrifugal compressor affected facility you must reduce methane and VOC emissions from each centrifugal compressor wet seal fluid degassing system by 95.0 percent or greater as required by § 60.5380a(a) and as demonstrated by the requirements of § 60.5413a.

* * * * *

(d) To achieve initial compliance with methane and VOC emission standards for your pneumatic controller affected facility you must comply with the requirements specified in paragraphs (d)(1) through (6) of this section, as applicable.

* * * * *

(f) For affected facilities at onshore natural gas processing plants, initial compliance with the methane and VOC standards is demonstrated if you are in compliance with the requirements of § 60.5400a.

* * * * *

■ 25. Amend § 60.5412a by revising paragraphs (a)(1)(i) and (a)(2) to read as follows:

§ 60.5412a What additional requirements must I meet for determining initial compliance with control devices used to comply with the emission standards for my centrifugal compressor, and storage vessel affected facilities?

* * * * *

(a) * * *

(1) * * *

(i) You must reduce the mass content of methane and VOC in the gases vented to the device by 95.0 percent by weight or greater as determined in accordance with the requirements of § 60.5413a(b), with the exceptions noted in § 60.5413a(a).

* * * * *

(2) Each vapor recovery device (e.g., carbon adsorption system or condenser) or other non-destructive control device must be designed and operated to reduce the mass content of methane and VOC in the gases vented to the device by 95.0 percent by weight or greater as determined in accordance with the requirements of § 60.5413a(b). As an alternative to the performance testing requirements in § 60.5413a(b), you may demonstrate initial compliance by conducting a design analysis for vapor recovery devices according to the requirements of § 60.5413a(c).

* * * * *

■ 26. Amend § 60.5413a by revising paragraphs (b)(4) introductory text,

(b)(4)(ii) and (d)(11)(iii) to read as follows:

§ 60.5413a What are the performance testing procedures for control devices used to demonstrate compliance at my centrifugal compressor and storage vessel affected facilities?

* * * * *

(b) * * *

(4) You must use Method 25A of appendix A-7 to this part to measure TOC, as propane, to determine compliance with the TOC exhaust gas concentration limit specified in § 60.5412a(a)(1)(ii) or (d)(1)(iv)(B). If you are determining compliance with the TOC exhaust gas concentration limit specified in § 60.5412a(d)(1)(iv)(B), you may also use Method 18 of appendix A-6 to this part to measure methane and ethane, and you may subtract the measured concentration of methane and ethane from the Method 25A measurement to demonstrate compliance with the concentration limit. You must determine the concentration in parts per million by volume on a wet basis and correct it to 3 percent oxygen, using the procedures in paragraphs (b)(4)(i) through (iii) of this section.

* * * * *

(ii) If you are determining compliance with the TOC exhaust gas concentration limit specified in § 60.5412a(d)(1)(iv)(B), you may subtract the concentration of methane and ethane from the Method 25A TOC, as propane, concentration for each run.

* * * * *

(d) * * *

(11) * * *

(iii) A manufacturer must demonstrate a destruction efficiency of at least 95 percent for THC, as propane. A control device model that demonstrates a destruction efficiency of 95 percent for THC, as propane, will meet the control requirement for 95 percent destruction of VOC and methane (if applicable) required under this subpart.

* * * * *

■ 27. Amend § 60.5415a by:

- a. Revising paragraphs (b)(1) and paragraph (f); and
- b. Removing paragraphs (i) and (j).

The revisions read as follows:

§ 60.5415a How do I demonstrate continuous compliance with the standards for my well, centrifugal compressor, reciprocating compressor, pneumatic controller, pneumatic pump, storage vessel, collection of fugitive emissions components at a well site, and collection of fugitive emissions components at a compressor station affected facilities, equipment leaks at onshore natural gas processing plants and sweetening unit affected facilities?

* * * * *

(b) * * *

(1) You must reduce methane and VOC emissions from the wet seal fluid degassing system by 95.0 percent or greater.

* * * * *

(f) For affected facilities at onshore natural gas processing plants, continuous compliance with methane and VOC requirements is demonstrated if you are in compliance with the requirements of § 60.5400a.

* * * * *

- 28. Amend § 60.5420a by:
 - a. Removing and reserving paragraph (b)(7)(i)(C);
 - b. Adding paragraph (b)(7)(iv);
 - c. Revising paragraphs (b)(9)(i), (b)(11), and (c)(5)(iv);
 - d. Removing and reserving paragraphs (c)(15)(ii) through (iv);
 - e. Revising the introductory text of paragraph (c)(15)(vii)(I) and paragraph (c)(15)(vii)(I)(8); and
 - f. Adding paragraphs (c)(15)(vii)(I)(9) and (c)(15)(ix).

The additions and revisions read as follows:

§ 60.5420a What are my notification, reporting, and recordkeeping requirements?

* * * * *

(b) * * *

(7) * * *

(iv) If you comply with the alternative GHG and VOC standard under § 60.5398b, in lieu of the information specified in paragraph (b)(7)(ii) of this section, you must provide the information specified in § 60.5424b.

* * * * *

(9) * * *

(i) For data collected using test methods supported by the EPA's Electronic Reporting Tool (ERT) as listed on the EPA's ERT website (<https://www.epa.gov/electronic-reporting-air-emissions/electronic-reporting-tool-ert>) at the time of the test, you must submit the results of the performance test to the EPA via the Compliance and Emissions Data Reporting Interface (CEDRI), except as outlined in this paragraph (b)(9)(i). (CEDRI can be accessed through the

EPA's Central Data Exchange (CDX) (<https://cdx.epa.gov/>.) Performance test data must be submitted in a file format generated through the use of the EPA's ERT or an alternate electronic file format consistent with the extensible markup language (XML) schema listed on the EPA's ERT website. The EPA will make all the information submitted through CEDRI available to the public without further notice to you. Do not use CEDRI to submit information you claim as confidential business information (CBI). Although we do not expect persons to assert a claim of CBI, if you wish to assert a CBI claim, you must submit a complete file generated through the use of the EPA's ERT or an alternate electronic file consistent with the XML schema listed on the EPA's ERT website, including information claimed to be CBI, to the EPA following the procedures in paragraphs (b)(9)(i)(A) and (B) of this section. Clearly mark the part or all of the information that you claim to be CBI. Information not marked as CBI may be authorized for public release without prior notice. Information marked as CBI will not be disclosed except in accordance with procedures set forth in 40 CFR part 2. All CBI claims must be asserted at the time of submission. Anything submitted using CEDRI cannot later be claimed CBI. Furthermore, under CAA section 114(c), emissions data is not entitled to confidential treatment, and the EPA is required to make emissions data available to the public. Thus, emissions data will not be protected as CBI and will be made publicly available. The same ERT or alternate file submitted to the CBI office with the CBI omitted must be submitted to the EPA via the EPA's CDX as described earlier in this paragraph (b)(9)(i).

(A) The preferred method to receive CBI is for it to be transmitted electronically using email attachments, File Transfer Protocol, or other online file sharing services. Electronic submissions must be transmitted directly to the OAQPS CBI Office at the email address oaqpscbi@epa.gov, and as described above, should include clear CBI markings. ERT files should be flagged to the attention of the Group Leader, Measurement Policy Group. If assistance is needed with submitting large electronic files that exceed the file size limit for email attachments, and if you do not have your own file sharing service, please email oaqpscbi@epa.gov to request a file transfer link.

(B) If you cannot transmit the file electronically, you may send CBI information through the postal service to the following address: U.S. EPA, Attn: OAQPS Document Control Officer

and Measurement Policy Group Leader, Mail Drop: C404-02, 109 T.W. Alexander Drive, P.O. Box 12055, RTP, NC 27711. The mailed CBI material should be double wrapped and clearly marked. Any CBI markings should not show through the outer envelope.

* * * * *

(11) You must submit reports to the EPA via CEDRI, except as outlined in this paragraph (b)(11). CEDRI can be accessed through the EPA's CDX (<https://cdx.epa.gov/>). You must use the appropriate electronic report template on the CEDRI website for this subpart (<https://www.epa.gov/electronic-reporting-air-emissions/cedri/>). If the reporting form specific to this subpart is not available on the CEDRI website at the time that the report is due, you must submit the report to the Administrator at the appropriate address listed in § 60.4. Once the form has been available in CEDRI for at least 90 calendar days, you must begin submitting all subsequent reports via CEDRI. The date reporting forms become available will be listed on the CEDRI website. Unless the Administrator or delegated state agency or other authority has approved a different schedule for submission of reports, the reports must be submitted by the deadlines specified in this subpart, regardless of the method in which the reports are submitted. The EPA will make all the information submitted through CEDRI available to the public without further notice to you. Do not use CEDRI to submit information you claim as CBI. Although we do not expect persons to assert a claim of CBI, if you wish to assert a CBI claim for some of the information in the report, submit a complete file using the appropriate electronic report template on the CEDRI website, including information claimed to be CBI, to the EPA following the procedures in paragraphs (b)(11)(i) and (ii) of this section. Clearly mark the part or all of the information that you claim to be CBI. Information not marked as CBI may be authorized for public release without prior notice. Information marked as CBI will not be disclosed except in accordance with procedures set forth in 40 CFR part 2. All CBI claims must be asserted at the time of submission. Anything submitted using CEDRI cannot later be claimed CBI. Furthermore, under CAA section 114(c), emissions data is not entitled to confidential treatment, and the EPA is required to make emissions data available to the public. Thus, emissions data will not be protected as CBI and will be made publicly available. Submit the same file submitted to the CBI office with the CBI

omitted must be submitted to the EPA via the EPA's CDX as described earlier in this paragraph (b)(11).

(i) The preferred method to receive CBI is for it to be transmitted electronically using email attachments, File Transfer Protocol, or other online file sharing services. Electronic submissions must be transmitted directly to the OAQPS CBI Office at the email address oaqpscbi@epa.gov, and as described above, should include clear CBI markings. Files should be flagged to the attention of the Oil and Natural Gas Sector Lead. If assistance is needed with submitting large electronic files that exceed the file size limit for email attachments, and if you do not have your own file sharing service, please email oaqpscbi@epa.gov to request a file transfer link.

(ii) If you cannot transmit the file electronically, you may send CBI information through the postal service to the following address: U.S. EPA, Attn: OAQPS Document Control Officer and Oil and Natural Gas Sector Lead, Mail Drop: C404-02, 109 T.W. Alexander Drive, P.O. Box 12055, RTP, NC 27711. The mailed CBI material should be double wrapped and clearly marked. Any CBI markings should not show through the outer envelope.

* * * * *

(c) * * *

(5) * * *

(iv) For storage vessels that are skid-mounted or permanently attached to something that is mobile (such as trucks, railcars, barges, or ships), records indicating the number of consecutive days that the vessel is located at a site in the crude oil and natural gas production segment, natural gas processing segment, or natural gas transmission and storage segment. If a storage vessel is removed from a site and, within 30 days, is either returned to the site or replaced by another storage vessel at the site to serve the same or similar function, then the entire period since the original storage vessel was first located at the site, including the days when the storage vessel was removed, will be added to the count towards the number of consecutive days.

* * * * *

(15) * * *

(vii) * * *

(I) Documentation of each fugitive emission detected during the monitoring survey, including the information specified in paragraphs (c)(15)(vii)(I)(1) through (9) of this section.

* * * * *

(8) For each fugitive emission component placed on delay of repair for

reason of replacement component unavailability, the operator must document: the date the component was added to the delay of repair list, the date the replacement fugitive component or part thereof was ordered, the anticipated component delivery date (including any estimated shipment or delivery date provided by the vendor), and the actual arrival date of the component.

(9) Date of planned shutdowns that occur while there are any components that have been placed on delay of repair.

* * * * *

(ix) If you comply with the alternative GHG and VOC standard under § 60.5398b, in lieu of the information specified in paragraphs (c)(15)(vi) through (vii) of this section, you must maintain the records specified in § 60.5424b.

* * * * *

§ 60.5421a What are my additional recordkeeping requirements for my affected facility subject to GHG and VOC requirements for onshore natural gas processing plants?

■ 29. Amend § 60.5421a by revising the section heading to read as set forth above.

§ 60.5422a What are my additional reporting requirements for my affected facility subject to GHG and VOC requirements for onshore natural gas processing plants?

■ 30. Amend § 60.5422a by revising the section heading to read as set forth above.

■ 31. Amend § 60.5430a by:

■ a. Revising definitions for “Compressor station”, “Crude Oil and Natural Gas Production source category”, “Equipment”, and “Fugitive emissions component”; and

■ b. Removing definition for “Natural gas transmission and storage segment”.

The revisions read as follows:

§ 60.5430a What definitions apply to this subpart?

* * * * *

Compressor station means any permanent combination of one or more compressors that move natural gas at increased pressure through gathering or transmission pipelines, or into or out of storage. This includes, but is not limited to, gathering and boosting stations and transmission compressor stations. The combination of one or more compressors located at a well site, or located at an onshore natural gas processing plant, is not a compressor station for purposes of § 60.5397a.

* * * * *

Crude oil and natural gas source category means:

(1) Crude oil production, which includes the well and extends to the point of custody transfer to the crude oil transmission pipeline or any other forms of transportation; and

(2) Natural gas production, processing, transmission, and storage, which include the well and extend to, but do not include, the local distribution company custody transfer station.

* * * * *

Equipment, as used in the standards and requirements in this subpart relative to the equipment leaks of GHG (in the form of methane) VOC from onshore natural gas processing plants, means each pump, pressure relief device, open-ended valve or line, valve, and flange or other connector that is in VOC service or in wet gas service, and any device or system required by those same standards and requirements in this subpart.

* * * * *

Fugitive emissions component means any component that has the potential to emit fugitive emissions of methane or VOC at a well site or compressor station, including valves, connectors, pressure relief devices, open-ended lines, flanges, covers and closed vent systems not subject to § 60.5411 or § 60.5411a, thief hatches or other openings on a controlled storage vessel not subject to § 60.5395 or § 60.5395a, compressors, instruments, and meters. Devices that vent as part of normal operations, such as natural gas-driven pneumatic controllers or natural gas-driven pumps, are not fugitive emissions components, insofar as the natural gas discharged from the device’s vent is not considered a fugitive emission. Emissions originating from other than the device’s vent, such as the thief hatch on a controlled storage vessel, would be considered fugitive emissions.

* * * * *

■ 32. Add subpart OOOOb, to part 60 to read as follows:

Subpart OOOOb—Standards of Performance for Crude Oil and Natural Gas Facilities for Which Construction, Modification or Reconstruction Commenced After December 6, 2022

60.5360b What is the purpose of this subpart?

60.5365b Am I subject to this subpart?

60.5370b When must I comply with this subpart?

60.5371b What GHG and VOC standards apply to super-emitter events?

60.5375b What GHG and VOC standards apply to well completions at well affected facilities?

60.5376b What GHG and VOC standards apply to gas well liquids unloading operations at well affected facilities?

60.5377b What GHG and VOC standards apply to associated gas wells at well affected facilities?

60.5380b What GHG and VOC standards apply to centrifugal compressor affected facilities?

60.5385b What GHG and VOC standards apply to reciprocating compressor affected facilities?

60.5386b What test methods and procedures must I use for my centrifugal compressor and reciprocating compressor affected facilities?

60.5390b What GHG and VOC standards apply to process controller affected facilities?

60.5393b What GHG and VOC standards apply to pump affected facilities?

60.5395b What GHG and VOC standards apply to storage vessel affected facilities?

60.5397b What GHG and VOC standards apply to fugitive emissions components affected facilities?

60.5398b What alternative GHG and VOC standards apply to fugitive emissions components affected facilities and what inspection and monitoring requirements apply to covers and closed vent systems when using an alternative technology?

60.5399b What are the alternative means of emission limitations for GHG and VOC from well completions, liquids unloading operations, centrifugal compressors, reciprocating compressors, fugitive emissions components, and process unit equipment affected facilities; and what are the alternative fugitive emissions standards based on State, local, and Tribal programs?

60.5400b What GHG and VOC standards apply to process unit equipment affected facilities?

60.5401b What are the alternative GHG and VOC standards for process unit equipment affected facilities?

60.5402b What are the exceptions to the GHG and VOC standards for process unit equipment affected facilities?

60.5403b What test methods and procedures must I use for my process unit equipment affected facilities?

60.5405b What standards apply to sweetening unit affected facilities?

60.5406b What test methods and procedures must I use for my sweetening unit affected facilities?

60.5407b What are the requirements for monitoring of emissions and operations from my sweetening unit affected facilities?

60.5408b What is an optional procedure for measuring hydrogen sulfide in acid gas—Tutwiler Procedure?

60.5410b How do I demonstrate initial compliance with the standards for each of my affected facilities?

60.5411b What additional requirements must I meet to determine initial compliance for my covers and closed vent systems?

60.5412b What additional requirements must I meet for determining initial compliance of my control devices?

- 60.5413b What are the performance testing procedures for control devices?
- 60.5415b How do I demonstrate continuous compliance with the standards for each of my affected facilities?
- 60.5416b What are the initial and continuous cover and closed vent system inspection and monitoring requirements?
- 60.5417b What are the continuous monitoring requirements for my control devices?
- 60.5420b What are my notification, reporting, and recordkeeping requirements?
- 60.5421b What are my additional recordkeeping requirements for process unit equipment affected facilities?
- 60.5422b What are my additional reporting requirements for process unit equipment affected facilities?
- 60.5423b What are my additional recordkeeping and reporting requirements for sweetening unit affected facilities?
- 60.5424b What are my additional recordkeeping and reporting requirements if I comply with the alternative GHG and VOC standards for fugitive emissions components affected facilities and covers and closed vent systems?
- 60.5425b What parts of the General Provisions apply to me?
- 60.5430b What definitions apply to this subpart?
- 60.5432b How do I determine whether a well is a low pressure well using the low pressure well equation?
- 60.5433b–60.5439b [Reserved]
- Table 1 to Subpart OOOOb of Part 60—
Alternative Technology Periodic Screening Frequency at Well Sites, Centralized Production, and Compressor Stations Facilities Subject to AVO Inspections with Quarterly OGI or EPA Method 21 Monitoring
- Table 2 to Subpart OOOOb of Part 60—
Alternative Technology Periodic Screening Frequency at Well Sites and Centralized Production Facilities Subject to AVO Inspections and/or Semiannual OGI or EPA Method 21 Monitoring
- Table 3 to Subpart OOOOb of Part 60—
Required Minimum Initial SO₂ Emission Reduction Efficiency (Z_i)
- Table 4 to Subpart OOOOb of Part 60—
Required Minimum SO₂ Emission Reduction Efficiency (Z_c)
- Table 5 to Subpart OOOOb of Part 60—
Applicability of General Provisions to Subpart OOOOb

§ 60.5360b What is the purpose of this subpart?

(a) *Scope.* This subpart establishes emission standards and compliance schedules for the control of the pollutant greenhouse gases (GHG). The greenhouse gas standard in this subpart is in the form of a limitation on emissions of methane from affected facilities in the crude oil and natural gas source category that commence construction, modification, or reconstruction after December 6, 2022.

This subpart also establishes emission standards and compliance schedules for the control of volatile organic compounds (VOC) and sulfur dioxide (SO₂) emissions from affected facilities in the crude oil and natural gas source category that commence construction, modification, or reconstruction after December 6, 2022.

(b) *Prevention of Significant Deterioration (PSD) and title V thresholds for Greenhouse Gases.* (1) For the purposes of 40 CFR 51.166(b)(49)(ii), with respect to GHG emissions from affected facilities, the “pollutant that is subject to the standard promulgated under section 111 of the Act” shall be considered the pollutant that otherwise is subject to regulation under the Act as defined in 40 CFR 51.166(b)(48) and in any State Implementation Plan (SIP) approved by the EPA that is interpreted to incorporate, or specifically incorporates, 40 CFR 51.166(b)(48).

(2) For the purposes of 40 CFR 52.21(b)(50)(ii), with respect to GHG emissions from affected facilities, the “pollutant that is subject to the standard promulgated under section 111 of the Act” shall be considered the pollutant that otherwise is subject to regulation under the Clean Air Act as defined in 40 CFR 52.21(b)(49).

(3) For the purposes of 40 CFR 70.2, with respect to GHG emissions from affected facilities, the “pollutant that is subject to any standard promulgated under section 111 of the Act” shall be considered the pollutant that otherwise is “subject to regulation” as defined in 40 CFR 70.2.

(4) For the purposes of 40 CFR 71.2, with respect to GHG emissions from affected facilities, the “pollutant that is subject to any standard promulgated under section 111 of the Act” shall be considered the pollutant that otherwise is “subject to regulation” as defined in 40 CFR 71.2.

(c) *Exemption.* You are exempt from the obligation to obtain a permit under 40 CFR part 70 or 40 CFR part 71, provided you are not otherwise required by law to obtain a permit under 40 CFR 70.3(a) or 40 CFR 71.3(a).

Notwithstanding the previous sentence, you must continue to comply with the provisions of this subpart.

§ 60.5365b Am I subject to this subpart?

You are subject to the applicable provisions of this subpart if you are the owner or operator of one or more of the onshore affected facilities listed in paragraphs (a) through (i) of this section, that is located within the Crude Oil and Natural Gas source category, as defined in § 60.5430b, for which you commence construction, modification, or

reconstruction after December 6, 2022. Facilities located inside and including the Local Distribution Company (LDC) custody transfer station are not subject to this subpart.

(a) Each well affected facility, which is a single well drilled for the purpose of producing oil or natural gas.

(1) In addition to § 60.14, a “modification” of an existing well occurs when:

(i) An existing well is hydraulically fractured, or

(ii) An existing well is hydraulically refractured.

(2) For the purposes of a well affected facility, a liquids unloading event is not considered to be a modification.

(3) Except as provided in § 60.5365b(e)(3)(ii)(C) and (i)(3)(ii), any action described by paragraphs (a)(1)(i) and (ii) of this section, by itself, does not affect the modification status of process unit equipment, centrifugal or reciprocating compressors, pumps, or process controllers.

(b) Each centrifugal compressor affected facility, which is a single centrifugal compressor. A centrifugal compressor located at a well site is not an affected facility under this subpart. A centrifugal compressor located at a centralized production facility is an affected facility under this subpart.

(c) Each reciprocating compressor affected facility, which is a single reciprocating compressor. A reciprocating compressor located at a well site is not an affected facility under this subpart. A reciprocating compressor located at a centralized production facility is an affected facility under this subpart.

(d) Each process controller affected facility, which is the collection of natural gas-driven process controllers at a well site, centralized production facility, onshore natural gas processing plant, or a compressor station. Natural gas-driven process controllers that function as emergency shutdown devices and process controllers that are not driven by natural gas are not included in the affected facility.

(1) For the purposes of § 60.5390b, in addition to the definition in § 60.14, a modification occurs when the number of natural gas-driven process controllers in the affected facility is increased by one or more.

(2) For the purposes of § 60.5390b, owners and operators may choose to apply reconstruction as defined in § 60.15(b) based on the fixed capital cost of the new process controllers in accordance with paragraph (d)(2)(i) of this section, or the definition of reconstruction based on the number of natural gas-driven process controllers in

the affected facility in accordance with paragraph (d)(2)(ii) of this section. Owners and operators may choose which definition of reconstruction to apply and whether to comply with paragraph (d)(2)(i) or (ii) of this section; they do not need to apply both. If owners and operators choose to comply with paragraph (d)(2)(ii) of this section they may demonstrate compliance with § 60.15(b)(1) by showing that more than 50 percent of the number of natural gas-driven process controllers in the affected facility is replaced. That is, if an owner or operator meets the definition of reconstruction through the “number of controllers” criterion in (d)(2)(ii) of this section, they will have shown that the “fixed capital cost of the new components exceeds 50 percent of the fixed capital cost that would be required to construct a comparable entirely new facility,” as required in § 60.15(b)(1). Therefore, an owner or operator may comply with the remaining provisions of § 60.15 that reference “fixed capital cost” through an initial showing that the number of natural gas-driven process controllers replaced exceeds 50 percent. For purposes of paragraphs (d)(2)(i) and (ii), “commenced” means that an owner or operator has undertaken a continuous program of natural gas-driven process controller replacement or that an owner or operator has entered into a contractual obligation to undertake and complete, within a reasonable time, a continuous program of natural gas-driven process controller replacement.

(i) If the owner or operator applies the definition of reconstruction in § 60.15(b)(1), reconstruction occurs when the fixed capital cost of the new process controllers exceeds 50 percent of the fixed capital cost that would be required to replace all the natural gas-driven process controllers in the affected facility. The “fixed capital cost of the new process controllers” includes the fixed capital cost of all natural gas-driven process controllers which are or will be replaced pursuant to all continuous programs of component replacement which are commenced within any 24-month rolling period following December 6, 2022.

(ii) If the owner or operator applies the definition of reconstruction based on the percentage of natural gas-driven process controllers replaced, reconstruction occurs when greater than 50 percent of the natural gas-driven process controllers at a site are replaced. The percentage includes all natural gas-driven process controllers which are or will be replaced pursuant to all continuous programs of natural gas-driven process controller replacement

which are commenced within any 24-month rolling period following December 6, 2022. If an owner or operator determines reconstruction based on the percentage of natural gas-driven process controllers that are replaced, the owner or operator must also comply with § 60.15(a).

(e) Each storage vessel affected facility, which is a tank battery that has the potential for emissions as specified in either paragraph (e)(1)(i) or (ii) of this section. A tank battery with the potential for emissions below both of the thresholds specified in paragraphs (e)(1)(i) and (ii) of this section is not a storage vessel affected facility provided the owner/operator keeps records of the potential for emissions calculation for the life of the storage vessel or until such time the tank battery becomes a storage vessel affected facility because the potential for emissions meets or exceeds either threshold specified in either paragraph (e)(1)(i) or (ii) of this section.

(1)(i) Potential for VOC emissions equal to or greater than 6 tons per year (tpy) as determined in paragraph (e)(2) of this section.

(ii) Potential for methane emissions equal to or greater than 20 tpy as determined in paragraph (e)(2) of this section.

(2) The potential for VOC and methane emissions must be calculated as the cumulative emissions from all storage vessels within the tank battery as specified by the applicable requirements in paragraphs (e)(2)(i) through (iii) of this section. The determination may take into account requirements under a legally and practicably enforceable limit in an operating permit or other requirement established under a Federal, state, local, or Tribal authority.

(i) For purposes of determining the applicability of a storage vessel tank battery as an affected facility, a legally and practicably enforceable limit must include the elements provided in paragraphs (e)(2)(i)(A) through (F) of this section.

(A) A quantitative production limit and quantitative operational limit(s) for the equipment, or quantitative operational limits for the equipment;

(B) An averaging time period for the production limit in (e)(2)(i)(A) of this section, if a production-based limit is used, that is equal to or less than 30 days;

(C) Established parametric limits for the production and/or operational limit(s) in (e)(1)(i)(A) of this section, and where a control device is used to achieve an operational limit, an initial compliance demonstration (*i.e.*,

performance test) for the control device that establishes the parametric limits;

(D) Ongoing monitoring of the parametric limits in (e)(2)(i)(C) of this section that demonstrates continuous compliance with the production and/or operational limit(s) in (e)(2)(i)(A) of this section;

(E) Recordkeeping by the owner or operator that demonstrates continuous compliance with the limit(s) in (e)(2)(i)(A) through (D) of this section; and

(F) Periodic reporting that demonstrates continuous compliance.

(ii) For each tank battery located at a well site or centralized production facility, you must determine the potential for VOC and methane emissions within 30 days after startup of production, or within 30 days after an action specified in paragraphs (e)(3)(i) and (ii) of this section, except as provided in paragraph (e)(5)(iv) of this section. The potential for VOC and methane emissions must be calculated using a generally accepted model or calculation methodology that accounts for flashing, working, and breathing losses, based on the maximum average daily throughput to the tank battery determined for a 30-day period of production.

(iii) For each tank battery not located at a well site or centralized production facility, including each tank battery located at a compressor station or onshore natural gas processing plant, you must determine the potential for VOC and methane emissions prior to startup of the compressor station, onshore natural gas processing plant, or other facility within 30 days after an action specified in paragraphs (e)(3)(i) and (ii) of this section, using either method described in paragraph (e)(2)(iii)(A) or (B) of this section.

(A) Determine the potential for VOC and methane emissions using a generally accepted model or calculation methodology that accounts for flashing, working and breathing losses and based on the throughput to the tank battery established in a legally and practicably enforceable limit in an operating permit or other requirement established under a Federal, state, local, or Tribal authority; or

(B) Determine the potential for VOC and methane emissions using a generally accepted model or calculation methodology that accounts for flashing, working and breathing losses and based on projected maximum average daily throughput. Maximum average daily throughput is determined using a generally accepted engineering model (*e.g.*, volumetric condensate rates from the tank battery based on the maximum

gas throughput capacity of each producing facility) to project the maximum average daily throughput for the tank battery.

(3) For the purposes of § 60.5395b, the following definitions of

“reconstruction” and “modification” apply for determining when an existing tank battery becomes a storage vessel affected facility under this subpart.

(i) “Reconstruction” of a tank battery occurs when the potential for VOC or methane emissions to meet or exceed either of the thresholds specified in paragraphs (e)(1)(i) or (ii) of this section and

(A) at least half of the storage vessels are replaced in the existing tank battery that consists of more than one storage vessel; or

(B) the provisions of § 60.15 are met for the existing tank battery.

(ii) “Modification” of a tank battery occurs when any of the actions in paragraphs (e)(3)(ii)(A) through (D) of this section occurs and the potential for VOC or methane emissions meet or exceed either of the thresholds specified in paragraphs (e)(1)(i) or (ii) of this section.

(A) A storage vessel is added to an existing tank battery;

(B) One or more storage vessels are replaced such that the cumulative storage capacity of the existing tank battery increases;

(C) For tank batteries at well sites or centralized production facilities, an existing tank battery receives additional crude oil, condensate, intermediate hydrocarbons, or produced water throughput from actions, including but not limited to, the addition of operations or a production well, or changes to operations or a production well (including hydraulic fracturing or refracturing of the well).

(D) For tank batteries not located at a well site or centralized production facility, including each tank battery at compressor stations or onshore natural gas processing plants, an existing tank battery receives additional fluids which cumulatively exceed the throughput used in the most recent (*i.e.*, prior to an action in paragraphs (e)(3)(ii)(A), (B) or (D) of this section) determination of the potential for VOC or methane emissions.

(4) A storage vessel affected facility that subsequently has its potential for VOC emissions decrease to less than 6 tpy shall remain an affected facility under this subpart.

(5) For storage vessels not subject to a legally and practicably enforceable limit in an operating permit or other requirement established under Federal, state, local, or Tribal authority, any vapor from the storage vessel that is

recovered and routed to a process through a vapor recovery unit designed and operated as specified in this section is not required to be included in the determination of potential for VOC or methane emissions for purposes of determining affected facility status, provided you comply with the requirements of paragraphs (e)(5)(i) through (iv) of this section.

(i) You meet the cover requirements specified in § 60.5411b(b).

(ii) You meet the closed vent system requirements specified in § 60.5411b(a)(2) through (4) and (c).

(iii) You must maintain records that document compliance with paragraphs (e)(5)(i) and (ii) of this section.

(iv) In the event of removal of apparatus that recovers and routes vapor to a process, or operation that is inconsistent with the conditions specified in paragraphs (e)(5)(i) and (ii) of this section, you must determine the storage vessel’s potential for VOC emissions according to this section within 30 days of such removal or operation.

(6) The requirements of this paragraph (e)(6) apply to each storage vessel affected facility immediately upon startup, startup of production, or return to service. A storage vessel affected facility or portion of a storage vessel affected facility that is reconnected to the original source of liquids remains a storage vessel affected facility subject to the same requirements that applied before being removed from service. Any storage vessel that is used to replace a storage vessel affected facility, or portion of a storage vessel affected facility, or used to expand a storage vessel affected facility assumes the affected facility status of the storage vessel affected facility being replaced or expanded.

(7) A storage vessel with a capacity greater than 100,000 gallons used to recycle water that has been passed through two stage separation is not a storage vessel affected facility.

(f) Each process unit equipment affected facility, which is the group of all equipment within a process unit at an onshore natural gas processing plant is an affected facility.

(1) Addition or replacement of equipment for the purpose of process improvement that is accomplished without a capital expenditure shall not by itself be considered a modification under this subpart.

(2) Equipment associated with a compressor station, dehydration unit, sweetening unit, underground storage vessel, field gas gathering system, or liquefied natural gas unit is covered by §§ 60.5400b, 60.5401b, 60.5402b,

60.5421b, and 60.5422b if it is located at an onshore natural gas processing plant. Equipment not located at the onshore natural gas processing plant site is exempt from the provisions of §§ 60.5400b, 60.5401b, 60.5402b, 60.5421b, and 60.5422b.

(g) Each sweetening unit affected facility as defined by paragraphs (g)(1) and (2) of this section.

(1) Each sweetening unit that processes natural gas produced from either onshore or offshore wells is an affected facility; and

(2) Each sweetening unit that processes natural gas followed by a sulfur recovery unit is an affected facility.

(3) Facilities that have a design capacity less than 2 long tons per day (LT/D) of hydrogen sulfide (H₂S) in the acid gas (expressed as sulfur) are required to comply with recordkeeping and reporting requirements specified in § 60.5423b(c) but are not required to comply with §§ 60.5405b through 60.5407b and §§ 60.5410b(i) and 60.5415b(i).

(4) Sweetening facilities producing acid gas that is completely re-injected into oil-or-gas-bearing geologic strata or that is otherwise not released to the atmosphere are not subject to §§ 60.5405b through 60.5407b, 60.5410b(i), 60.5415b(i), and 60.5423b.

(h) Each pump affected facility, which is the collection of natural gas-driven pumps at a well site, centralized production facility, onshore natural gas processing plant, or a compressor station. Pumps that are not driven by natural gas are not included in the pump affected facility.

(1) For the purposes of § 60.5393b, in addition to the definition in § 60.14, a modification occurs when the number of natural gas-driven pumps in the affected facility is increased by one or more.

(2) For the purposes of § 60.5390b, owners and operators may choose to apply reconstruction as defined in § 60.15(b) based on the fixed capital cost of the new pumps in accordance with paragraph (h)(2)(i) of this section, or the definition of reconstruction based on the number of natural gas-driven pumps in the affected facility in accordance with paragraph (h)(2)(ii) of this section. Owners and operators may choose which definition of reconstruction to apply and whether to comply with paragraph (h)(2)(i) or (ii) of this section; they do not need to apply both. If owners and operators choose to comply with paragraph (h)(2)(ii) of this section they may demonstrate compliance with § 60.15(b)(1) by showing that more than 50 percent of the number of natural gas-

driven pumps is replaced. That is, if an owner or operator meets the definition of reconstruction through the “number of pumps” criterion in (h)(2)(ii) of this section, they will have shown that the “fixed capital cost of the new components exceeds 50 percent of the fixed capital cost that would be required to construct a comparable entirely new facility,” as required in § 60.15(b)(1). Therefore, an owner or operator may comply with the remaining provisions of § 60.15 that reference “fixed capital cost” through an initial showing that the number of natural gas-driven pumps replaced exceeds 50 percent. For purposes of paragraphs (h)(2)(i) and (ii) of this section, “commenced” means that an owner or operator has undertaken a continuous program of component replacement or that an owner or operator has entered into a contractual obligation to undertake and complete, within a reasonable time, a continuous program of natural gas-driven pump replacement.

(i) If the owner or operator applies the definition of reconstruction in § 60.15, reconstruction occurs when the fixed capital cost of the new pumps exceeds 50 percent of the fixed capital cost that would be required to replace all the natural gas-driven pumps in the affected facility. The “fixed capital cost of the new pumps” includes the fixed capital cost of all natural gas-driven pumps which are or will be replaced pursuant to all continuous programs of component replacement which are commenced within any 24-month rolling period following December 6, 2022.

(ii) If the owner or operator applies the definition of reconstruction based on the percentage of natural gas-driven pumps replaced, reconstruction occurs when greater than 50 percent of the natural gas-driven pumps in the affected facility are replaced. The percentage includes all natural gas-driven pumps which are or will be replaced pursuant to all continuous programs of component replacement which are commenced within any 24-month rolling period following December 6, 2022. If an owner or operator determines reconstruction based on the percentage of natural gas-driven pumps that are replaced, the owner or operator must comply with § 60.15(a).

(3) A natural gas-driven pump that is in operation less than 90 days per calendar year is not part of an affected facility under this subpart. For the purposes of this section, any period of operation during a calendar day counts toward the 90-calendar day threshold.

(i) Each fugitive emissions components affected facility, which is

the collection of fugitive emissions components at a well site, centralized production facility, or a compressor station.

(1) For purposes of § 60.5397b and § 60.5398b, a “modification” to a well site occurs when:

(i) A new well is drilled at an existing well site;

(ii) A well at an existing well site is hydraulically fractured; or

(iii) A well at an existing well site is hydraulically refractured.

(2) For purposes of § 60.5397b and § 60.5398b, a “modification” to centralized production facility occurs when:

(i) Any of the actions in paragraphs (i)(1)(i) through (iii) of this section occurs at an existing centralized production facility;

(ii) A well sending production to an existing centralized production facility is modified, as defined in paragraphs (i)(1)(i) through (iii) of this section; or

(iii) A well site subject to the requirements of § 60.5397b or § 60.5398b removes all major production and processing equipment, such that it becomes a wellhead only well site and sends production to an existing centralized production facility.

(3) For purposes of § 60.5397b, a “modification” to a compressor station occurs when:

(i) An additional compressor is installed at a compressor station; or

(ii) One or more compressors at a compressor station is replaced by one or more compressors of greater total horsepower than the compressor(s) being replaced. When one or more compressors is replaced by one or more compressors of an equal or smaller total horsepower than the compressor(s) being replaced, installation of the replacement compressor(s) does not trigger a modification of the compressor station for purposes of § 60.5397b.

§ 60.5370b When must I comply with this subpart?

(a) You must be in compliance with the standards of this subpart no later than May 7, 2024 or upon initial startup, whichever date is later, except as specified in paragraph (a)(1) of this section for reciprocating compressor affected facilities, paragraphs (a)(2) and (3) of this section for storage vessel affected facilities, paragraph (a)(4) of this section for process unit equipment affected facilities at onshore natural gas processing plants, paragraph (a)(5) of this section for process controllers, paragraph (a)(6) of this section for pumps, paragraph (a)(7) of this section for centrifugal compressor affected facilities, and paragraphs § 60.5377b(b) or (c) for associated gas wells.

(1) You must comply with the requirements of § 60.5385b(a) for your reciprocating compressor affected facility as specified in paragraph (a)(1)(i), (ii), or (iii) of this section, as applicable.

(i) You must comply with the requirements of § 60.5385b(a)(1) and (d)(3) on or before 8,760 hours of operation after May 7, 2024, on or before 8,760 hours of operation after last rod packing replacement, or on or before 8,760 hours of operation after startup, whichever date is later; and

(ii) You must comply with the requirements of § 60.5385b(a)(2) within 8,760 hours after compliance with § 60.5385b(a)(1) and (d)(3).

(iii) You must comply with the requirements of § 60.5385b(d)(1) and (2) for your reciprocating compressor upon initial startup.

(2) You must comply with the requirements of paragraphs § 60.5395b(a)(1) for your storage vessel affected facility as specified in paragraphs (a)(2)(i) or (ii) of this section, as applicable.

(i) Within 30 days after startup of production, or within 30 days after reconstruction or modification of the storage vessel affected facility, for each storage vessel affected facility located at a well site or centralized production facility.

(ii) Prior to startup of the compressor station or onshore natural gas processing plant, or within 30 days after reconstruction or modification of the storage vessel affected facility, for each storage vessel affected facility located at a compressor station or onshore natural gas processing plant.

(3) You must comply with the requirements of paragraph § 60.5395b(a)(2) as specified in paragraph (a)(3)(i) or (ii) of this section, as applicable:

(i) For each storage vessel affected facility located at a well site or centralized production facility, you must achieve the required emissions reductions within 30 days after the determination in paragraph (a)(2)(i) of this section.

(ii) For storage vessel affected facilities located at a compressor station or onshore natural gas processing plant, you must achieve the required emissions reductions within 30 days after the determination in paragraph (a)(2)(ii) of this section.

(4) You must comply with the requirements of § 60.5400b for all process unit equipment affected facilities at a natural gas processing plant, as soon as practicable but no later than 180 days after the initial startup of the process unit.

(5) For process controller affected facilities, you must comply with the requirements of paragraph (a)(5)(i) or (ii) of this section, as applicable.

(i) Any process controller affected facilities may comply with § 60.5390b(b)(1) and (2) or (3) as an alternative to compliance with § 60.5390b(a) until May 7, 2025.

(ii) On or after May 7, 2025, process controller affected facilities must comply with § 60.5390b(a) or (b), as specified in those paragraphs.

(6) For pump affected facilities, you must comply with the requirements of paragraph (a)(6)(i) or (ii) of this section, as applicable.

(i) Any pump affected facility may comply with § 60.5393b(b)(2) through (8), as applicable, as an alternative to compliance with § 60.5393b(a) until May 7, 2025.

(ii) On or after May 7, 2025, pump affected facilities must comply with § 60.5393b(a) or (b), as specified in those paragraphs.

(7) For centrifugal compressor affected facilities, you must comply with the requirements of paragraph (a)(7)(i) or (ii) of this section, as applicable.

(i) You must comply with the requirements of § 60.5380b(a)(1) and (2), or (a)(3) for your reciprocating compressor upon initial startup.

(ii) Each centrifugal compressor affected facility that uses dry seals, each self-contained wet seal compressor, and each centrifugal compressor on the Alaska North Slope equipped with sour seal oil separator and capture system, complying with one of the alternatives in § 60.5380b(a)(4), (5), or (6), must comply with the specified performance-based volumetric flow rate work practice standards on or before 8,760 hours of operation after May 7, 2024, on or before 8,760 hours of operation after last seal replacement, or on or before 8,760 hours of operation after startup, whichever date is later.

(b) At all times, including periods of startup, shutdown, and malfunction, owners and operators shall maintain and operate any affected facility including associated air pollution control equipment in a manner consistent with good air pollution control practice for minimizing emissions. Determination of whether acceptable operating and maintenance procedures are being used will be based on information available to the Administrator which may include, but is not limited to, monitoring results, opacity observations, review of operating and maintenance procedures, and inspection of the source. The provisions for exemption from

compliance during periods of startup, shutdown and malfunctions provided for in 40 CFR 60.8(c) do not apply to this subpart.

(c) You are exempt from the obligation to obtain a permit under 40 CFR part 70 or 40 CFR part 71, provided you are not otherwise required by law to obtain a permit under 40 CFR 70.3(a) or 40 CFR 71.3(a). Notwithstanding the previous sentence, you must continue to comply with the provisions of this subpart.

§ 60.5371b What GHG and VOC standards apply to super-emitter events?

This section applies to super-emitter events. For purposes of this section, a super-emitter event is defined as any emissions event that is located at or near an oil and natural gas facility (e.g., individual well site, centralized production facility, natural gas processing plant, or compressor station) and that is detected using remote detection methods and has quantified emission rate of 100 kg/hr of methane or greater. Paragraph (a) of this section describes the qualifications one must meet to apply to be a third-party notifier of super-emitter events. Paragraph (b) of this section describes the procedures for certifying third-party notifiers, as well as the procedures for petitioning the Agency for removal of a third-party notifier from the list of certified notifiers. Paragraph (c) of this section contains the required information that must be included in any notification submitted to the EPA from a certified third-party notifier and a timetable for notifications. The EPA shall review these notifications and if the EPA determines the notification is complete and does not contain information that the EPA finds to be erroneous or inaccurate to a reasonable degree of certainty, the EPA shall assign the notification a unique notification identification number, provide the notification to the owner or operator of the oil and natural gas facility identified in the notification, and post the notification, except for the owner/operator attribution, at www.epa.gov/super-emitter. Upon receiving such notification, owners or operators must take the actions listed in paragraphs (d) and (e) of this section. The EPA shall post the reports submitted under paragraph (e) of this section, § 60.5371(b) and § 60.5371a(b) of subparts OOOO and OOOOa of this part, and applicable State or Federal plan implementing § 60.5388c(b) of subpart OOOOc of this part, including owner/operator attributions that have been confirmed by the reports; where the reporting deadlines have passed but

no reports have been received, the EPA intends to post owner/operator attributions that the EPA reasonably believes to be accurate. The reports will be publicly available at www.epa.gov/super-emitter.

(a) *Qualifications for third-party notifiers.* An entity may apply to the Administrator under paragraph (b) of this section for approval as a third-party notifier if it meets the qualifications in this paragraph (a). The entity must be a person, as defined in 42 U.S.C. 7602(e), excluding the owner or operator of the site where the super-emitter event is detected, the Administrator, or the delegated authority. The entity must use a method that has been approved under § 60.5398b(d) for one of the technologies specified in paragraphs (a)(1) through (3) of this section.

(1) Satellite detection of methane emissions.

(2) Remote-sensing equipment on aircraft.

(3) Mobile monitoring platforms.

(b) *Third-party notifier certification.* An entity meeting the qualifications in paragraph (a) of this section may apply to be certified as a third-party notifier. Only entities certified as third-party notifiers may submit information on super-emitter events to the EPA under paragraph (c) of this section. An entity seeking certification as a third-party notifier must submit a request to the Administrator as described in paragraph (b)(1) of this section. Certified third-party notifiers must follow the recordkeeping requirements in paragraph (b)(2) of this section; failure to maintain the required records may result in loss of certification status. The Administrator will determine whether the request for certification is adequate and issue an approval or disapproval of the request as described in paragraph (b)(3) of this section. A certified third-party notifier must re-apply when material changes are made, as described in paragraph (b)(4) of this section. A third-party notifier may be removed from the list of certified notifiers as detailed in paragraph (b)(5) of this section.

(1) A request to be certified as a third-party notifier must be submitted to: U.S. EPA, Attn: Leader, Measurement Technology Group, Mail Drop: E143-02, 109 T.W. Alexander Drive, P.O. Box 12055, RTP, NC 27711. The request must include the supporting information in paragraphs (b)(1)(i) through (vi) of this section. If your submittal includes information claimed to be CBI, submit the portion of the information claimed as CBI to the OAQPS CBI office. The preferred method to receive CBI is for it to be

transmitted electronically using email attachments, File Transfer Protocol, or other online file sharing services. Electronic submissions must be transmitted directly to the OAQPS CBI Office at the email address oaqpscbi@epa.gov and should include clear CBI markings and be flagged to the attention of the Leader, Measurement Technology Group. If assistance is needed with submitting large electronic files that exceed the file size limit for email attachments, and if you do not have your own file sharing service, please email oaqpscbi@epa.gov to request a file transfer link. If you cannot transmit the file electronically, you may send CBI information through the postal service to the following address: U.S. EPA, Attn: OAQPS Document Control Officer and Measurement Technology Group Leader, Mail Drop: C404-02, 109 T.W. Alexander Drive, P.O. Box 12055, RTP, NC 27711. The mailed CBI material should be double wrapped and clearly marked. Any CBI markings should not show through the outer envelope.

(i) General identification information for the candidate third-party notifier requesting certification as a third-party notifier including the mailing address, the physical address, the name of a principal officer and an email address for the principal officer, and name of the certifying official(s) and the certifying official(s)'s email address.

(ii) Description of the technologies the entity will use to identify emissions that are 100 kg/hr of methane or greater. At a minimum, the description must include the following:

(A) Reference to the approval of the method to be used under § 60.5398b(d).

(B) Memorandum of Understanding (MOU) or contracting agreements with the technology provider(s) that will be used to identify super-emitter events (if applicable).

(iii) Curriculum vitae of the certifying official(s) detailing their work history, education, skill set, and training for evaluating the results of the technologies that will be used to identify super-emitter events.

(iv) The candidate third-party notifier's standard operating procedure(s) detailing the procedures and processes for data review. At a minimum, this must include the following:

(A) Procedures for evaluating the emission data provided by the technology, including the accuracy of the data and whether the data was collected in compliance with the method requirements approved under § 60.5398b(d).

(B) Process for verifying the accuracy of the locality of emissions.

(C) Process for identifying and verifying the owner or operator of a site where a super-emitter event occurs, including the source of information that will be used to make the identification.

(D) Procedures for handling potentially erroneous data.

(v) Description of the systems used for maintaining essential records identified in paragraph (b)(2) of this section.

(vi) A Quality Management Plan consistent with EPA's Quality Management Plan Standard (Directive No: CIO 2015-S-01.0, January 17, 2023) for Non-EPA organizations.

(2) Certified third-party notifiers must maintain the records identified in paragraphs (b)(2)(i) through (iii) of this section. Upon request, the certified third-party notifier must make these records available to the Administrator for review.

(i) Records for all surveys conducted by or sponsored by the certified third-party notifier, including outputs (*e.g.*, emission rates, locations) and associated data needed to confirm the accuracy of the outputs and the performance of the method used.

(ii) Records of all notifications of super-emitter events provided to the EPA. Retain any information collected that is used to evaluate the validity of a super-emitter event but which is not required to be submitted as part of the notification.

(iii) A copy of any records and/or identification of any databases used in the identification of the potential owner or operator of the site where a super-emitter event occurred.

(3) Based upon the Administrator's judgment of the completeness, reasonableness, and accuracy of the entity's request, the Administrator will approve or disapprove the entity for certification as a third-party notifier. For those third parties that receive approval, the Administrator will provide you a unique notifier ID. Starting 15 calendar days after being approved as a certified third-party notifier, the notifier may submit notifications of super-emitter events to the EPA as outlined in paragraph (c) of this section. All approved third-party notifiers shall be posted on the EPA website at www.epa.gov/emc-third-party-certifications.

(4) If a third-party notifier intends to make any significant changes to their procedures for identifying super-emitter events, meaning a change to the technology used to identify super-emitter events or a change to the certifying official(s), you must request an amendment to your certification and be recertified under paragraph (b)(1) of this section.

(5) A certified third-party notifier may be removed from the list of approved third-party notifiers in any of the circumstances listed in paragraphs (b)(5)(i) through (iii) of this section. Entities removed from the list of approved third-party notifiers cannot submit notifications to the EPA under paragraph (c) of this section. Entities may be added back to the list of approved third-party notifiers by receiving approval of a new certification request submitted under paragraph (b)(1) of this section.

(i) If a certified third-party notifier has made material changes to their procedures for identifying super-emitter events, meaning a change to the technology used to identify super-emitter events or a change to the certifying official, without seeking recertification.

(ii) If the Administrator finds that the certified third-party notifier has persistently submitted data with significant errors (*e.g.*, misidentification of the owner or operator) or if the third-party notifier has engaged in illegal activity during the assessment of a super-emitter event (*e.g.*, trespassing).

(iii) If the Administrator receives a petition from an owner or operator to remove a certified third-party notifier from the list of approved notifiers, as set forth below, and the Administrator makes the finding noted below. Any owner or operator that has received more than three notices with meaningful and/or demonstrable errors of a super-emitter event at the same oil and natural gas facility (*e.g.*, a well site, centralized production facility, natural gas processing plant, or compressor station) from the EPA that were submitted to the EPA by the same third party may petition the Administrator to remove that third party from the list of approved notifiers, by providing evidence that the claimed super-emitter events did not occur. Such petitions may not be used to dispute the methodology that were approved through the process described in § 60.5398b(d). The third party will be given the opportunity to respond to the petition. If, in the Administrator's discretion, the Administrator determines that the three notifications contain meaningful and/or demonstrable errors, including that the third party did not use the methane detection technology identified in their submittal, the emissions event did not exceed the threshold of 100 kg/hr of methane, the third-party knowingly misidentified the date of a super-emitter event, the third party may be removed by the Administrator from the list of

approved notifiers. The failure of the owner or operator to find the source of the super-emitter event upon subsequent inspection shall not be proof, by itself, of demonstrable error.

(c) *Notification of super-emitter events.* Notifications must be submitted to the EPA using the Super-Emitter Program Portal (available at <http://www.epa.gov/super-emitter>). Notifications must contain the information specified in paragraphs (c)(1) through (8) of this section. The EPA will review the submitted notifications of super-emitter events for completeness and accuracy. If the EPA determines that the notification is complete and does not contain information that the EPA finds to be inaccurate to a reasonable degree of certainty, the EPA will assign the notification a unique notification report identification number, make the notification publicly available at www.epa.gov/super-emitter, and provide the super-emitter event notification to the owner or operator identified in the notification. The EPA will not review and provide the notification to an owner or operator if the notification is submitted after the date specified in paragraph (c)(9) of this section.

(1) Unique Third-Party Notifier ID.

(2) Date of detection of the super-emitter event. If multiple surveys were required to detect and quantify the super-emitter event, the date of detection is the date of the final survey.

(3) Location of super-emitter event in latitude and longitude coordinates in decimal degrees to an accuracy and precision of four (4) decimals of a degree using the North American Datum of 1983.

(4) Owner(s) or operator(s) of any oil and natural gas facility (e.g., individual well site, centralized production facility, natural gas processing plant, or compressor station) within 50 meters of the latitude and longitude coordinates of the super-emitter event.

(5) Identification of the detection technology and reference to the approval of the technology used under § 60.5398b(d).

(6) Documentation (e.g., imagery) depicting the detected super-emitter event and the site from which the super-emitter event was detected.

(7) Quantified emission rate of the super-emitter event in kg/hr and associated uncertainty bounds (e.g., $1-\sigma$) of the measurement.

(8) Attestation statement, signed and dated by the third-party notifier certifying official submitting the data collected. The attestation must state: "I certify that I have been approved to be

a notifier under 40 CFR 60.5371b(b) and that the emission detection information included in this notification was collected and interpreted as described in this notification. Based on my professional knowledge and experience, and inquiry of personnel involved in the collection and analysis of the data, the certification submitted herein is true, accurate, and complete."

(9) The third-party notifier must submit the notification within 15 calendar days of the date of detection of the super-emitter event.

(d) *Identification of super-emitter events.* Within 5 calendar days of receiving a notification from the EPA of a super-emitter event, the owner or operator of an oil and natural gas facility (e.g., a well site, centralized production facility, natural gas processing plant, or compressor station) must initiate a super-emitter event investigation. The investigation must be conducted in accordance with this paragraph (d) and completed within 15 days of receiving the notification from the EPA. The owner or operator must maintain records of its super-emitter event investigations and report the findings from the investigation according to the requirements in paragraph (e) of this section.

(1) If you do not own or operate an oil and natural gas facility within 50 meters from the latitude and longitude provided in the notification, report this result to the EPA under paragraph (e) of this section. Your super-emitter event investigation is deemed complete.

(2) If you own or operate an oil and natural gas facility within 50 meters from the latitude and longitude provided in the notification, you must investigate to determine the source of super-emitter event. The investigation may include but is not limited to the actions specified below in paragraphs (d)(6)(i) through (v) of this section.

(i) Review any maintenance activities (e.g., liquids unloading) or process activities from the affected facilities subject to regulation under this subpart, starting from the date of detection of the super-emitter event as identified in the notification, until the date of investigation, to determine if the activities indicate any potential source(s) of the super-emitter event emissions.

(ii) Review all monitoring data from control devices (e.g., flares) from the affected facilities subject to regulation under this subpart from the initial date of detection of the super-emitter event as identified in the notification until the date of receiving the notification from the EPA. Identify any malfunctions of control devices or periods when the

control devices were not in compliance with applicable requirements and that indicate a potential source of the super-emitter event emissions.

(iii) If you conducted a fugitive emissions survey or periodic screening event in accordance with § 60.5397b or § 60.5398b(b) between the initial date of detection of the super-emitter event as identified in the notification and the date the notification from the EPA was received, review the results of the survey to identify any potential source(s) of the super-emitter event emissions.

(iv) If you conduct continuous monitoring with advanced methane detection technology in accordance with § 60.5398b(c), review the monitoring data collected on or after the initial date of detection of the super-emitter event as identified in the notification, until the date of receiving the notification from the EPA.

(v) Screen the entire oil and natural gas facility with OGI, Method 21 of appendix A-7 to this part, or an alternative test method(s) approved per § 60.5398b(d), to determine if a super-emitter event is present.

(3) If the source of the super-emitter event was found to be from fugitive emission components at a well site, centralized production facility, or compressor station subject to this subpart, you must comply with the repair requirements under § 60.5397b and the associated recordkeeping and reporting requirements under § 60.5420b(b)(9) and (c)(14).

(e) *Super-emitter event report.* You must submit the results of the super-emitter event investigation conducted under paragraph (d) of this section to the EPA in accordance with paragraph (e)(1) of this section. If the super-emitter event (i.e., emission at 100 kg/hr of methane or more) is ongoing at the time of the initial report, submit the additional information in accordance with paragraph (e)(2) of this section. You must attest to the information included in the report as specified in paragraph (e)(3) of this section.

(1) Within 15 days of receiving a notification from the EPA under paragraph (c) of this section, you must submit a report of the super-emitter event investigation conducted under paragraph (d) of this section through the Super-Emitter Program Portal. You must include the applicable information in paragraphs (e)(1)(i) through (viii) of this section in the report. If you have identified a demonstrable error in the notification, the report may include a statement of the demonstrable error.

(i) Notification Report ID of the super-emitter event notification.

(ii) Identification of whether you are the owner or operator of an oil and natural gas facility within 50 meters from the latitude and longitude provided in the EPA notification. If you do not own or operate an oil and natural gas facility within 50 meters from the latitude and longitude provided in the EPA notification, you are not required to report the information in paragraphs (e)(1)(iii) through (viii) of this section.

(iii) General identification information for the facility, including, facility name, the physical address, applicable ID Number (e.g., EPA ID Number, API Well ID Number), the owner or operator or responsible official (where applicable) and their email address.

(iv) Identification of whether there is an affected facility or associated equipment subject to regulation under this subpart at this oil and natural gas facility.

(v) Indication of whether you were able to identify the source of the super-emitter event. If you indicate you were unable to identify the source of the super-emitter event, you must certify that all applicable investigations specified in paragraph (d)(6)(i) through (v) of this section have been conducted for all affected facilities and associated equipment subject to this subpart that are at this oil and natural gas facility, and you have determined that the affected facilities and associated equipment are not the source of the super-emitter event. If you indicate that you were not able to identify the source of the super-emitter event, you are not required to report the information in paragraphs (e)(1)(vi) through (viii) of this section.

(vi) The source(s) of the super-emitter event.

(vii) Identification of whether the source of the super-emitter event is equipment subject to regulation under this subpart. If the source of the super-emitter event is equipment subject to regulation under this subpart, identify the applicable regulation(s) under this subpart.

(viii) Indication of whether the super-emitter event is ongoing at the time of the initial report submittal (i.e., emissions at 100 kg/hr of methane or more).

(A) If the super-emitter event is not ongoing at the time of the initial report submittal, provide the actual (or if unknown) estimated date and time the super-emitter event ended.

(B) If the super-emitter event is ongoing at the time of the initial report submittal, provide a short narrative of your plan to end the super-emitter event, including the targeted end date

for the efforts to be completed and the super-emitter event ended.

(2) If the super-emitter event is ongoing at the time of the initial report submittal, within 5 business days of the date the super-emitter event ends, you must update your initial report through the Super-Emitter Program Portal to provide the end date and time of the super-emitter event.

(3) You must sign the following attestation when submitting data into the Super-Emitter Program Portal: "I certify that the information provided in this report regarding the specified super-emitter event was prepared under my direction or supervision. I further certify that the investigations were conducted, and this report was prepared pursuant to the requirements of § 60.5371b(d) and (e). Based on my professional knowledge and experience, and inquiry of personnel involved in the assessment, the certification submitted herein is true, accurate, and complete. I am aware that knowingly false statements may be punishable by fine or imprisonment."

§ 60.5375b What GHG and VOC standards apply to well completions at well affected facilities?

(a) You must comply with the requirements of paragraphs (a)(1) through (3) of this section for each well completion operation with hydraulic fracturing and refracturing at a well affected facility, except as provided in paragraphs (f), (g) and (h) of this section. You must maintain a log as specified in paragraph (b) of this section.

(1) For each stage of the well completion operation, follow the requirements specified in paragraphs (a)(1)(i) through (iii) of this section.

(i) During the initial flowback stage, route the flowback into one or more well completion vessels or storage vessels and commence operation of a separator unless it is technically infeasible for a separator to function. The separator may be a production separator, but the production separator also must be designed to accommodate flowback. Any gas present in the initial flowback stage is not subject to control under this section.

(ii) During the separation flowback stage, route all recovered liquids from the separator to one or more well completion vessels or storage vessels, re-inject the recovered liquids into the well or another well, or route the recovered liquids to a collection system. Route the recovered gas from the separator into a gas flow line or collection system, re-inject the recovered gas into the well or another well, use the recovered gas as an onsite

fuel source, or use the recovered gas for another useful purpose that a purchased fuel or raw material would serve. If it is technically infeasible to route the recovered gas as required above, follow the requirements of paragraph (a)(2) of this section. If, at any time during the separation flowback stage, it is technically infeasible for a separator to function, you must comply with paragraph (a)(1)(i) of this section.

(iii) You must have the separator onsite or otherwise available for use at a centralized production facility or well pad that services the well completion affected facility during well completions. The separator must be available and ready for use to comply with paragraph (a)(1)(ii) of this section during the entirety of the flowback period, except as provided in paragraphs (a)(1)(iii)(A) through (C) of this section.

(A) A well that is not hydraulically fractured or refractured with liquids, or that does not generate condensate, intermediate hydrocarbon liquids, or produced water such that there is no liquid collection system at the well site is not required to have a separator onsite.

(B) If conditions allow for liquid collection, then the operator must immediately stop the well completion operation, install a separator, and restart the well completion operation in accordance with paragraph (a)(1) of this section.

(C) The owner or operator of a well that meets the criteria of paragraph (a)(1)(iii)(A) or (B) of this section must submit the report in § 60.5420b(b)(2) and maintain the records in § 60.5420b(c)(1)(iii).

(2) If it is technically infeasible to route the recovered gas as required in § 60.5375b(a)(1)(ii), then you must capture and direct recovered gas to a completion combustion device, except in conditions that may result in a fire hazard or explosion, or where high heat emissions from a completion combustion device may negatively impact tundra, permafrost or waterways. Completion combustion devices must be equipped with a reliable continuous pilot flame.

(3) You have a general duty to safely maximize resource recovery and minimize releases to the atmosphere during flowback and subsequent recovery.

(b) You must maintain a log for each well completion operation at each well affected facility. The log must be completed on a daily basis for the duration of the well completion operation and must contain the records specified in § 60.5420b(c)(1)(iii).

(c) You must demonstrate initial compliance with the well completion operation standards that apply to well affected facilities as required by § 60.5410b(a).

(d) You must demonstrate continuous compliance with the well completion operation standards that apply to well affected facilities as required by § 60.5415b(a).

(e) You must perform the required notification, reporting and recordkeeping as required by § 60.5420b(a)(2), (b)(1) and (2), and (c)(1).

(f) For each well affected facility specified in paragraphs (f)(1) and (2) of this section, you must comply with the requirements of paragraphs (f)(3) and (4) of this section.

(1) Each well completion operation with hydraulic fracturing at a wildcat or delineation well.

(2) Each well completion operation with hydraulic fracturing at a non-wildcat low pressure well or non-delineation low pressure well.

(3) You must comply with paragraph (f)(3)(i) of this section. You must also comply with paragraph (b) of this section. As an alternative, if you are able to operate a separator, you may comply with paragraph (b) and (f)(3)(ii) of this section. Compliance with paragraphs (f)(3)(i) or (ii) of this section is not required if you meet the requirements of paragraph (g) of this section.

(i) Route all flowback to a completion combustion device, except in conditions that may result in a fire hazard or explosion, or where high heat emissions from a completion combustion device may negatively impact tundra, permafrost or waterways. Completion combustion devices must be equipped with a reliable continuous pilot flame.

(ii) Route all flowback into one or more well completion vessels and commence operation of a separator unless it is technically infeasible for a separator to function. You must have the separator onsite or otherwise available for use at the wildcat well, delineation well, or low pressure well. The separator must be available and ready for use to comply with paragraph (f)(3)(ii) of this section during the entirety of the flowback period. Any gas present in the flowback before the separator can function is not subject to control under this section. Capture and direct recovered gas to a completion combustion device, except in conditions that may result in a fire hazard or explosion, or where high heat emissions from a completion combustion device may negatively impact tundra, permafrost, or waterways. Completion

combustion devices must be equipped with a reliable continuous pilot flame.

(4) You must submit the notification as specified in § 60.5420b(a)(2), submit annual reports as specified in § 60.5420b(b)(1) and (2) and maintain records specified in § 60.5420b(c)(1)(i) through (iii) and (vii) for each wildcat well, each delineation well, and each low pressure well.

(g) For each well completion affected facility with less than 300 scf of gas per stock tank barrel of oil produced, you must comply with paragraphs (g)(1) and (2) of this section.

(1) You must maintain records specified in § 60.5420b(c)(1)(vi).

(2) You must submit reports specified in § 60.5420b(b)(1) and (2).

(h) A well modified in accordance with § 60.5365b(a)(1)(ii) (*i.e.*, an existing well that is hydraulically refractured) is exempt from the well completion operation standards in paragraphs (b) through (d) of this section, when the requirements of paragraphs (a)(1) through (3) of this section are met.

§ 60.5376b What GHG and VOC standards apply to gas well liquids unloading operations at well affected facilities?

(a) *General requirements.* You must comply with the requirements of this section for each gas well liquids unloading operation at your gas well affected facility as specified by paragraphs (a)(1) and (2) of this section. You have a general duty to safely maximize resource recovery and minimize releases to the atmosphere during gas well liquids unloading operations.

(1) If a gas well liquids unloading operation technology or technique employed does not result in venting of methane and VOC emissions to the atmosphere, you must comply with the requirements specified in paragraphs (a)(1)(A) and (B). If an unplanned venting event occurs, you must meet the requirements specified in paragraphs (c) through (f) of this section.

(A) Comply with the recordkeeping requirements specified in § 60.5420b(c)(2)(i).

(B) Submit the information specified in § 60.5420b(b)(1) and (b)(3)(i) in the annual report.

(2) If a gas well liquids unloading operation technology or technique vents methane and VOC emissions to the atmosphere, you must comply with the requirements specified in paragraphs (b) and (c), or paragraph (g) of this section.

(b) *Work Practice Standards.* If a gas well liquids unloading operation employs a technology or technique that vents methane and VOC emissions to the atmosphere, you must comply with

the requirements in paragraphs (b)(1) through (3) and paragraphs (c) through (f) of this section.

(1) Employ best management practices to minimize venting of methane and VOC emissions as specified in paragraph (c) of this section for each gas well liquids unloading operation.

(2) Comply with the recordkeeping requirements specified in § 60.5420b(c)(2)(ii).

(3) Submit the information specified in § 60.5420b(b)(1) and (b)(3)(ii) in the annual report.

(c) *Best management practice requirements.* For each gas well liquids unloading operation complying with paragraphs (a)(2) and (b) of this section, you must develop, maintain, and follow a best management practice plan to minimize venting of methane and VOC emissions to the maximum extent possible from each gas well liquids unloading operation. This best management practice plan must meet the minimum criteria specified in paragraphs (c)(1) through (4) of this section.

(1) Include steps that create a differential pressure to minimize the need to vent a well to unload liquids,

(2) Include steps to reduce wellbore pressure as much as possible prior to opening the well to the atmosphere,

(3) Unload liquids through the separator where feasible, and

(4) Close all wellhead vents to the atmosphere and return the well to production as soon as practicable.

(d) *Initial compliance.* You must demonstrate initial compliance with the standards that apply to well liquids unloading operations at your well affected facilities as required by § 60.5410b(b).

(e) *Continuous compliance.* You must demonstrate continuous compliance with the standards that apply to well liquids unloading operations at your well affected facilities as required by § 60.5415b(b).

(f) *Recordkeeping and reporting.* You must perform the required notification, recordkeeping and reporting requirements as specified in § 60.5420b(b)(3) and (c)(2).

(g) *Other compliance options.* Reduce methane and VOC emissions from well affected facility gas wells that unload liquids by 95.0 percent by complying with the requirements specified in paragraphs (g)(1) and (2) of this section and meeting the initial and continuous compliance and recordkeeping and reporting requirements specified in paragraphs (g)(3) through (5) of this section.

(1) You must route emissions through a closed vent system to a control device

that meets the conditions specified in § 60.5412b.

(2) You must route emissions through a closed vent system that meets the requirements of § 60.5411b(a) and (c).

(3) You must demonstrate initial compliance with standards that apply to well affected facility gas well liquids unloading as required by § 60.5410b(b).

(4) You must demonstrate continuous compliance with standards that apply to well affected facility gas well liquids unloading as required by § 60.5415b(f).

(5) You must perform the reporting as required by § 60.5420b(b)(1), (3), and (11) through (13), as applicable, and the recordkeeping as required by § 60.5420b(c)(2), (8), and (10) through (13), as applicable.

§ 60.5377b What GHG and VOC standards apply to associated gas wells at well affected facilities?

(a) You must comply with either paragraph (a)(1), (2), (3), or (4) of this section for each associated gas well upon startup and at all times, except as provided in paragraphs (b) through (f) of this section. You must also comply with paragraphs (h), (i), and (j) of this section.

(1) Recover the associated gas from the separator and route the recovered gas into a gas gathering flow line or collection system to a sales line.

(2) Recover the associated gas from the separator and use the recovered gas as an onsite fuel source.

(3) Recover the associated gas from the separator and use the recovered gas for another useful purpose that a purchased fuel or raw material would serve.

(4) Recover the associated gas from the separator and reinject the recovered gas into the well or inject the recovered gas into another well.

(b) For associated gas wells that commenced construction between May 7, 2024 and May 7, 2026, you can comply with the requirements in paragraph (f) of this section continually upon startup instead of paragraph (a) of this section until May 7, 2026 if you demonstrate and certify that it is not feasible to comply with paragraphs (a)(1), (2), (3), and (4) of this section due to technical reasons in accordance with paragraph (g) of this section. After May 7, 2026 you must continually comply with paragraph (a) of this section at all times.

(c) For associated gas wells that commenced construction between December 6, 2022, and May 7, 2024, and for associated gas wells that undergo reconstruction or modification after December 6, 2022, you can comply with the requirements in paragraph (f) of this section instead of paragraph (a) of this

section if you demonstrate and certify that it is not feasible to comply with paragraph (a)(1), (2), (3), and (4) of this section due to technical reasons in accordance with paragraph (g) of this section. Associated gas wells that are modified or reconstructed must comply with paragraph (a) or (f) of this section upon startup and at all times thereafter.

(d) If you are complying with paragraph (a) of this section, you may temporarily route the associated gas to a flare or control device that achieves a 95.0 percent reduction in VOC and methane emissions in the situations and for the durations identified in paragraphs (d)(1), (2), (3), or (4) of this section. The associated gas must be routed through a closed vent system that meets the requirements of § 60.5411b(a) and (c) and the control device must meet the conditions specified in § 60.5412b during the period when the associated gas is routed to the flare. Records must be kept of all instances in which associated gas is temporarily routed to a flare or to a control device in accordance with § 60.5420b(c)(3)(i)(B) and reported in the annual report in accordance with § 60.5420b(b)(4)(i)(B).

(1) During a malfunction or incident that endangers the safety of operator personnel or the public you are allowed to route to a flare or control device for 24 hours or less per incident.

(2) During repair, maintenance including blow downs, a production test, or commissioning, you are allowed to route to a flare or control device for 24 hours or less per incident.

(3) For wells complying with paragraph (a)(1) of this section, during a temporary interruption in service from the gathering or pipeline system you are allowed to route to a flare or route to a control device for the duration of the temporary interruption not to exceed 30 days per incident.

(4) During periods when the composition of the associated gas does not meet pipeline specifications for sources complying with paragraph (a)(1) of this section, or when the composition of the associated gas does not meet the quality requirements for use as a fuel for sources complying with paragraph (a)(2) of this section, or when the composition of the associated gas does not meet the quality requirements for another useful purpose for sources complying with paragraph (a)(3) of this section, you are allowed to route to a flare or control device until the associated gas meets the required specifications or for 72 hours per incident, whichever is less.

(e) If you are complying with paragraph (a), (d), or (f) of this section, you may vent the associated gas in the situations and for the durations

identified in paragraphs (e)(1), (2), or (3) of this section per incident. The cumulative period of venting must not exceed 24 hours for any calendar year. Records must be kept of all venting instances in accordance with § 60.5420b(c)(3)(ii) and reported in the annual report in accordance with § 60.5420b(b)(4)(ii).

(1) For up to 12 hours per incident to protect the safety of personnel.

(2) For up to 30 minutes per incident during bradenhead monitoring.

(3) For up to 30 minutes per incident during a packer leakage test.

(f) You must route the associated gas to a control device that reduces methane and VOC emissions by at least 95.0 percent. The associated gas must be routed through a closed vent system that meets the requirements of § 60.5411b(a) and (c) and the control device must meet the conditions specified in § 60.5412b.

(1) For associated gas wells identified in paragraph (b) of this section, you can comply with the requirements in paragraph (f) of this section for up to a one year period if you demonstrate and certify that it is not feasible to comply with paragraph (a)(1), (2), (3), and (4) of this section due to technical reasons in accordance with paragraph (g) of this section. This allowance is renewable each year with an updated technical infeasibility demonstration and certification in accordance with paragraph (g) of this section. Associated gas wells identified in paragraph (b) of this section are not allowed to comply with the requirements in paragraph (f) of this section after May 7, 2026.

(2) For associated gas wells identified in paragraph (c) of this section, you can comply with the requirements in paragraph (f) of this section for up to a one year period if you demonstrate and certify that it is not feasible to comply with paragraph (a)(1), (2), (3), and (4) of this section due to technical reasons in accordance with paragraph (g) of this section. This allowance is renewable each year with an updated technical infeasibility demonstration and certification in accordance with paragraph (g) of this section.

(g) For affected sources identified in paragraphs (b) and (c) of this section that are complying with the requirements in paragraph (f) of this section, you must demonstrate that it is not feasible to comply with paragraph (a)(1), (2), (3), and (4) of this section due to technical reasons by providing a detailed analysis documenting and certifying the technical reasons for this infeasibility.

(1) The demonstration must address the technical infeasibility for all options

identified in (a)(1), (2), (3), and (4) of this section.

(2) This demonstration must be certified by a professional engineer or another qualified individual with expertise in the uses of associated gas. The following certification, signed and dated by the qualified professional engineer or other qualified individual shall state: "I certify that the assessment of technical and safety infeasibility was prepared under my direction or supervision. I further certify that the assessment was conducted, and this report was prepared pursuant to the requirements of § 60.5377b(b)(1). Based on my professional knowledge and experience, and inquiry of personnel involved in the assessment, the certification submitted herein is true, accurate, and complete."

(3) This demonstration and certification are valid for no more than 12 months. You must re-analyze the feasibility of complying with paragraphs (a)(1), (2), (3), and (4) of this section and finalize a new demonstration and certification each year.

(4) Documentation of these demonstrations, along with the certifications, must be maintained in accordance with § 60.5420b(c)(3)(iii) and submitted in annual reports in accordance with § 60.5420b(b)(4)(iii)(C) and (D).

(h) You must demonstrate initial compliance with the standards that apply to associated gas wells as required by § 60.5410b(c).

(i) You must demonstrate continuous compliance with the standards that apply to associated gas wells as required by § 60.5415b(c).

(j) You must perform the reporting as required by § 60.5420b(b)(1) and (4), and (b)(11) and (12), as applicable; and the recordkeeping as required by § 60.5420b(c)(3) and (8), and (c)(10) through (13), as applicable.

§ 60.5380b What GHG and VOC standards apply to centrifugal compressor affected facilities?

Each centrifugal compressor affected facility must comply with the GHG and VOC standards in paragraphs (a) through (d) of this section.

(a) Each centrifugal compressor affected facility that uses wet seals must comply with the GHG and VOC standards in paragraphs (a)(1), (2), or (3) of this section. Each self-contained wet seal compressor, and each centrifugal compressor on the Alaska North Slope equipped with sour seal oil separator and capture system, must comply with the GHG and VOC standards in paragraphs (a)(1) and (2) of this section, or one of the alternatives in (a)(3)

through (5) of this section, as applicable, and (a)(8) of this section. Each centrifugal compressor affected facility that uses dry seals must comply with paragraphs (a)(6) through (8) of this section, or with one of the alternatives in paragraph (a)(9) of this section.

(1) You must reduce methane and VOC emissions from each centrifugal compressor wet seal fluid degassing system by 95.0 percent.

(2) If you use a control device to reduce emissions, you must equip the wet seal fluid degassing system with a cover that meets the requirements of § 60.5411b(b). The cover must be connected through a closed vent system that meets the requirements of § 60.5411b(a) and (c) and the closed vent system must be routed to a control device that meets the conditions specified in § 60.5412b.

(3) As an alternative to routing the closed vent system to a control device, you may route the closed vent system to a process. If you route the emissions to a process, you must equip the wet seal fluid degassing system with a cover that meets the requirements of § 60.5411b(b). The cover must be connected through a closed vent system that meets the requirements of § 60.5411b(a) and (c).

(4) If you own or operate a self-contained wet seal centrifugal compressor you may comply with the GHG and VOC requirements as specified in paragraph (a)(4)(i) through (iii) of this section, using volumetric flow rate as a surrogate, in lieu of meeting the requirements specified in paragraphs (a)(1) and (2) of this section. You must determine the volumetric flow rate in accordance with paragraph (a)(7)(i) of this section.

(i) The volumetric flow rate must not exceed 3 standard cubic feet per minute (scfm) per seal. If the individual seals are manifolded to a single open-ended vent line, the volumetric flow rate must not exceed the sum of the individual seals multiplied by 3 scfm. If the volumetric flow rate, measured in accordance with paragraph (a)(7)(i) of this section exceeds 3 scfm multiplied by the number of wet seals connected to the vent, the seals connected to the measured vent must be repaired as provided in paragraph (a)(8) of this section.

(ii) You must conduct your first volumetric flow rate measurement from your self-contained wet seal compressor on or before 8,760 hours of operation after May 7, 2024 or on or before 8,760 hours of operation after startup, whichever date is later.

(iii) You must conduct subsequent volumetric flow rate measurements from your self-contained wet seal centrifugal

compressor on or before 8,760 hours of operation after the previous measurement which demonstrates compliance with the 3 scfm volumetric flow rate per seal. If the individual seals are manifolded to a single open-ended vent line, the volumetric flow rate must not exceed the sum of the individual seals multiplied by 3 scfm.

(5) If you own or operate a centrifugal compressor on the Alaska North Slope equipped with seal oil separator and capture system, you may comply with the GHG and VOC requirements specified in paragraphs (a)(5)(i) through (iii) of this section using volumetric flow rate as a surrogate, in lieu of meeting the requirements specified in paragraphs (a)(1) and (2). You must determine the volumetric flow rate in accordance with paragraph (a)(7)(ii) of this section.

(i) The volumetric flow rate per seal must not exceed 9 scfm per seal. If the individual seals are manifolded to a single open-ended vent line, the volumetric flow rate must not exceed the sum of the individual seals multiplied by 9 scfm. If the volumetric flow rate, measured in accordance with paragraph (a)(7)(ii) of this section exceeds 9 scfm multiplied by the number of wet seals connected to the vent, the seals connected to the measured vent must be repaired as provided in paragraph (a)(8) of this section.

(ii) You must conduct your first volumetric flow rate measurement from your Alaska North Slope centrifugal compressor equipped with a sour seal oil separator and capture system on or before 8,760 hours of operation after May 7, 2024 or on or before 8,760 hours of operation after startup, whichever date is later.

(iii) You must conduct subsequent volumetric flow rate measurements from your Alaska North Slope centrifugal compressor equipped with sour seal separator and capture system on or before 8,760 hours of operation after the previous measurement which demonstrates compliance with the 9 scfm volumetric flow rate per seal. If the individual seals are manifolded to a single open-ended vent line, the volumetric flow rate must not exceed the sum of the individual seals multiplied by 9 scfm.

(6) If you own or operate a centrifugal compressor equipped with dry seals, you must comply with the GHG and VOC requirements as specified in paragraphs (a)(6)(i) through (iii), using volumetric flow rate as a surrogate. You must determine the volumetric flow rate in accordance with paragraph (a)(7)(iii) of this section.

(i) The volumetric flow rate per seal must not exceed 10 standard cubic feet per minute (scfm) per seal. If the individual seals are manifolded to a single open-ended vent line, the volumetric flow rate must not exceed the sum of the individual seals multiplied by 10 scfm. If the volumetric flow rate, measured in accordance with paragraph (a)(7)(iii) of this section exceeds 10 scfm multiplied by the number of dry seals connected to the vent, the seals connected to the measured vent must be repaired as provided in paragraph (a)(8) of this section.

(ii) You must conduct your first volumetric flow rate measurement from your centrifugal compressor equipped with a dry seal on or before 8,760 hours of operation after May 7, 2024 or on or before 8,760 hours of operation after startup, whichever date is later.

(iii) You must conduct subsequent volumetric flow rate measurements from your centrifugal compressor equipped with dry seals on or before 8,760 hours of operation after the previous measurement which demonstrates compliance with the 10 scfm volumetric flow rate per seal. If the individual seals are manifolded to a single open-ended vent line, the volumetric flow rate must not exceed the sum of the individual seals multiplied by 10 scfm.

(7) You must determine the volumetric flow rate for your centrifugal compressor, as specified in paragraphs (a)(7)(i) through (iii) of this section.

(i) You must determine the volumetric flow rate from your self-contained wet seal centrifugal compressor wet seal as specified in paragraph (a)(7)(i)(A) or (B) of this section. If the volumetric flow rate exceeds 3 scfm multiplied by the number of wet seals connected to the vent, the wet seals connected to the measured vent must be repaired as provided in paragraph (a)(8) of this section.

(A) For self-contained wet seal centrifugal compressors in operating-mode or in standby-pressurized-mode, determine volumetric flow rate at standard conditions from each self-contained wet seal centrifugal compressor wet seal using one of the methods specified in paragraphs (a)(7)(i)(A)(1) through (3) of this section.

(1) You may choose to use any of the methods set forth in § 60.5386b(a) to screen for leaks/emissions. For the purposes of this paragraph, when using any of the methods in § 60.5386b(a), emissions are detected whenever a leak is detected according to the method. If emissions are detected using the methods set forth in § 60.5386b(a), then you must use one of the methods

specified in paragraph (a)(7)(i)(A)(2) or (3) of this section to determine the volumetric flow rate. If emissions are not detected using the methods in § 60.5386b(a), then you may assume that the volumetric emissions are zero.

(2) Use a temporary or permanent flow meter according to methods set forth in § 60.5386b(b).

(3) Use a high-volume sampler according to the method set forth in § 60.5386b(c).

(B) For conducting measurements on manifolded groups of self-contained wet seal centrifugal compressor seals, you must determine the volumetric flow rate from the self-contained wet seal centrifugal compressor seal as specified in paragraph (a)(7)(i)(B)(1) or (2) of this section.

(1) Measure at a single point in the manifold downstream of all self-contained wet seal centrifugal compressor seal inputs and, if practical, prior to comingling with other non-compressor emission sources.

(2) Determine the volumetric flow rate at standard conditions from the common stack using one of the methods specified in paragraph (a)(7)(i)(A)(1) through (3) of this section.

(ii) You must determine the volumetric flow rate from your centrifugal compressor on the Alaska North Slope equipped with sour seal oil separator and capture system as specified in paragraph (a)(7)(ii)(A) or (B) of this section. If the volumetric flow rate exceeds 9 scfm multiplied by the number of wet seals connected to the vent, the wet seals connected to the measured vent must be repaired as provided in paragraph (a)(8) of this section.

(A) For centrifugal compressors in operating-mode or in standby-pressurized-mode, determine volumetric flow rate at standard conditions from each centrifugal compressor on the Alaska North Slope equipped with a sour seal oil separator and capture system using one of the methods specified in paragraphs (a)(7)(ii)(A)(1) through (3) of this section.

(1) You may choose to use any of the methods set forth in § 60.5386b(a) to screen for leaks/emissions. For the purposes of this paragraph, when using any of the methods in § 60.5386b(a), emissions are detected whenever a leak is detected according to the method. If emissions are detected using the methods set forth in § 60.5386b(a), then you must use one of the methods specified in paragraph (a)(7)(ii)(A)(2) or (3) of this section to determine the volumetric flow rate. If emissions are not detected using the methods in

§ 60.5386b(a), then you may assume that the volumetric emissions are zero.

(2) Use a temporary or permanent flow meter according to methods set forth in § 60.5386b(b).

(3) Use a high-volume sampler according to the method set forth in § 60.5386b(c).

(B) For conducting measurements on manifolded groups of centrifugal compressors on the Alaska North Slope equipped with sour seal oil separators and capture systems, you must determine the volumetric flow rate from the centrifugal compressors equipped with sour seal oil separators and capture systems as specified in paragraph (a)(7)(ii)(B)(1) or (2) of this section.

(1) Measure at a single point in the manifold downstream of all centrifugal compressors on the Alaska North Slope equipped with sour seal oil separator and capture system wet seal inputs and, if practical, prior to comingling with other non-compressor emission sources.

(2) Determine the volumetric flow rate at standard conditions from the common stack using one of the methods specified in paragraph (a)(7)(ii)(A)(1) through (3) of this section.

(iii) You must determine the volumetric flow rate from your centrifugal compressor equipped with dry seals as specified in paragraph (a)(7)(iii)(A) or (B) of this section. If the volumetric flow rate exceeds 10 scfm multiplied by the number of dry seals connected to the vent, the dry seals connected to the measured vent must be repaired as provided in paragraph (a)(8) of this section.

(A) For centrifugal compressors equipped with dry seals in operating-mode or in standby-pressurized-mode, determine volumetric flow rate at standard conditions from each centrifugal compressor equipped with dry seals using one of the methods specified in paragraphs (a)(7)(iii)(A)(1) through (3) of this section.

(1) You may choose to use any of the methods set forth in § 60.5386b(a) to screen for leaks/emissions. For the purposes of this paragraph, when using any of the methods in § 60.5386b(a), emissions are detected whenever a leak is detected according to the method. If emissions are detected using the methods set forth in § 60.5386b(a), then you must use one of the methods specified in paragraph (a)(7)(iii)(A)(2) or (3) of this section to determine the volumetric flow rate. If emissions are not detected using the methods in § 60.5386b(a), then you may assume that the volumetric emissions are zero.

(2) Use a temporary or permanent flow meter according to methods set forth in § 60.5386b(b).

(3) Use a high-volume sampler according to the method set forth in § 60.5386b(c).

(B) For conducting measurements on manifolded groups of centrifugal compressors equipped with dry seals, you must determine the volumetric flow rate from the dry seal centrifugal compressors as specified in paragraph (a)(7)(iii)(B)(1) or (2) of this section.

(1) Measure at a single point in the manifold downstream of all centrifugal compressors equipped with dry seals inputs and, if practical, prior to comingling with other non-compressor emission sources.

(2) Determine the volumetric flow rate at standard conditions from the common stack using one of the methods specified in paragraph (a)(7)(iii)(A)(1) through (3) of this section.

(8) The seal must be repaired within 90 calendar days after the date of the volumetric emissions measurement that exceeds the applicable required flow rate per seal. You must conduct follow-up volumetric flow rate measurements from seal vents using the methods specified in paragraph (a)(7) of this section within 15 days after the repair to document that the rate has been reduced to less than the applicable required flow rate per seal. If the individual seals are manifolded to a single open-ended vent line or vent, the volumetric flow rate must be reduced to less than the sum of the individual seals multiplied by the applicable required flow rate per seal specified in paragraph (a)(4) through (6) of this section, as applicable. Delay of repair will be allowed if the conditions in paragraphs (a)(8)(i) or (ii) of this section are met.

(i) If the repair of the wet or dry seal is technically infeasible, would require a vent blowdown, a compressor station shutdown, or would be unsafe to repair during operation of the unit, the repair must be completed during the next scheduled compressor station shutdown for maintenance, after a scheduled vent blowdown, or within 2 years of the date of the volumetric emissions measurement that exceeds the applicable required flow rate per seal, whichever is earliest. A vent blowdown is the opening of one or more blowdown valves to depressurize major production and processing equipment, other than a storage vessel.

(ii) If the repair requires replacement of the compressor seal or a part thereof, but the replacement cannot be acquired and installed within the repair timelines specified under this section due to the condition specified in paragraph (a)(8)(ii)(A) of this section, the repair must be completed in accordance with paragraph (a)(8)(ii)(B) of this section and

documented in accordance with § 60.5420b(c)(4)(iii)(F) through (H).

(A) Seal or part thereof supplies had been sufficiently stocked but are depleted at the time of the required repair.

(B) The required replacement must be ordered no later than 10 calendar days after the centrifugal compressor seal is added to the delay of repair list due to parts unavailability. The repair must be completed as soon as practicable, but no later than 30 calendar days after receipt of the replacement seal or part, unless the repair requires a compressor station shutdown. If the repair requires a compressor station shutdown, the repair must be completed in accordance with the timeframe specified in paragraph (a)(8)(i) of this section.

(9) As an alternative to meeting the requirements for centrifugal compressors with dry seals specified in paragraphs (a)(6) through (8) of this section, owners or operators are allowed to comply with the standard by meeting the requirements specified in paragraphs (a)(9)(i) and (ii), or (a)(9)(iii) of this section.

(i) You must reduce methane and VOC emissions from each centrifugal compressor dry seal system by 95.0 percent.

(ii) If you use a control device to reduce emissions, you must equip the dry seal system with a cover that meets the requirements of § 60.5411b(b). The cover must be connected through a closed vent system that meets the requirements of § 60.5411b(a) and (c) and the closed vent system must be routed to a control device that meets the conditions specified in § 60.5412b.

(iii) As an alternative to routing the closed vent system to a control device, you may route the closed vent system to a process. If you route the emissions to a process, you must equip the dry seal system with a cover that meets the requirements of § 60.5411b(b). The cover must be connected through a closed vent system that meets the requirements of § 60.5411b(a) and (c).

(b) You must demonstrate initial compliance with the standards that apply to centrifugal compressor affected facilities as required by § 60.5410b(d).

(c) You must demonstrate continuous compliance with the standards that apply to centrifugal compressor affected facilities as required by § 60.5415b(d).

(d) You must perform the reporting as required by § 60.5420b(b)(1) and (5), and (b)(11) through (13), as applicable; and the recordkeeping as required by § 60.5420b(c)(4), and (8) through (13), as applicable.

§ 60.5385b What GHG and VOC standards apply to reciprocating compressor affected facilities?

Each reciprocating compressor affected facility must comply with the GHG and VOC standards, using volumetric flow rate as a surrogate, in paragraphs (a) through (c) of this section, or the GHG and VOC standards in paragraph (d) of this section. You must also comply with the requirements in paragraphs (e) through (g) of this section.

(a) The volumetric flow rate of each cylinder, measured in accordance with paragraph (b) or (c) of this section, must not exceed 2 scfm per individual cylinder. If the individual cylinders are manifolded to a single open-ended vent line, the volumetric flow rate must not exceed the sum of the individual cylinders multiplied by 2 scfm. You must conduct measurements of the volumetric flow rate in accordance with the schedule specified in paragraphs (a)(1) and (2) of this section and determine the volumetric flow rate per cylinder in accordance with paragraph (b) or (c) of this section. If the volumetric flow rate, measured in accordance with paragraph (b) or (c) of this section, for a cylinder exceeds 2 scfm per cylinder (or a combined volumetric flow rate greater than the number of compression cylinders multiplied by 2 scfm), the rod packing or packings must be repaired or replaced as provided in paragraph (a)(3) of this section.

(1) You must conduct your first volumetric flow rate measurements from your reciprocating compressor rod packing vent on or before 8,760 hours of operation after May 7, 2024, or on or before 8,760 hours of operation after last rod packing replacement, or on or before 8,760 hours of operation after startup, whichever date is later.

(2) You must conduct subsequent volumetric flow rate measurements from your reciprocating compressor rod packing vent on or before 8,760 hours of operation after the previous measurement which demonstrates compliance with the applicable volumetric flow rate of 2 scfm per cylinder (or a combined volumetric flow rate greater than the number of compression cylinders multiplied by 2 scfm), or on or before 8,760 hours of operation after last rod packing replacement, whichever date is later.

(3) The rod packing must be repaired or replaced within 90 calendar days after the date of the volumetric emissions measurement that exceeded 2 scfm per cylinder. You must conduct follow-up volumetric flow rate measurements from compressor vents

using the methods specified in paragraph (b) of this section within 15 days after the repair (or rod packing replacement) to document that the rate has been reduced to less than 2 scfm per cylinder. Delay of repair will be allowed if the conditions in paragraphs (a)(3)(i) or (ii) of this section are met.

(i) If the repair (or rod packing replacement) is technically infeasible, would require a vent blowdown, a compressor station shutdown, or would be unsafe to repair during operation of the unit, the repair (or rod packing replacement) must be completed during the next scheduled compressor station shutdown for maintenance, after a scheduled vent blowdown, or within 2 years of the date of the volumetric emissions measurement that exceeds the applicable required flow rate per cylinder, whichever is earliest. A vent blowdown is the opening of one or more blowdown valves to depressurize major production and processing equipment, other than a storage vessel.

(ii) If the repair requires replacement of the rod packing or a part, but the replacement cannot be acquired and installed within the repair timelines specified under this section due to the condition specified in paragraph (a)(3)(ii)(A) of this section, the repair must be completed in accordance with paragraph (a)(3)(ii)(B) of this section and documented in accordance with § 60.5420b(c)(5)(viii) through (x).

(A) Rod packing or part supplies had been sufficiently stocked but are depleted at the time of the required repair.

(B) The required rod packing or part replacement must be ordered no later than 10 calendar days after the reciprocating compressor is added to the delay of repair list due to parts unavailability. The repair must be completed as soon as practicable, but no later than 30 calendar days after receipt of the replacement rod packing or part, unless the repair requires a compressor station shutdown. If the repair requires a compressor station shutdown, the repair must be completed in accordance with the timeframe specified in paragraph (a)(3)(i) of this section.

(b) You must determine the volumetric flow rate per cylinder from your reciprocating compressor as specified in paragraph (b)(1) or (2) of this section.

(1) For reciprocating compressor rod packing equipped with an open-ended vent line on compressors in operating or standby pressurized mode, determine the volumetric flow rate of the rod packing using one of the methods specified in paragraphs (b)(1)(i) through (iii) of this section.

(i) Determine the volumetric flow rate at standard conditions from the open-ended vent line using a high-volume sampler according to methods set forth in § 60.5386b(c).

(ii) Determine the volumetric flow rate at standard conditions from the open-ended vent line using a temporary or permanent meter, according to methods set forth in § 60.5386b(b).

(iii) Any of the methods set forth in § 60.5386b(a) to screen for leaks and emissions. For the purposes of this paragraph, emissions are detected whenever a leak is detected according to any of the methods in § 60.5386b(a). If emissions are detected using the methods set forth in § 60.5386b(a), then you must use one of the methods specified in paragraph (b)(1)(i) and (ii) of this section to determine the volumetric flow rate per cylinder. If emissions are not detected using the methods in § 60.5386b(a), then you may assume that the volumetric flow rate is zero.

(2) For reciprocating compressor rod packing not equipped with an open-ended vent line on compressors in operating or standby pressurized mode, you must determine the volumetric flow rate of the rod packing using the methods specified in paragraphs (b)(2)(i) and (ii) of this section.

(i) You must use the methods described in § 60.5386b(a) to conduct leak detection of emissions from the rod packing case into an open distance piece, or, for compressors with a closed distance piece, you must conduct annual leak detection of emissions from the rod packing vent, distance piece vent, compressor crank case breather cap, or other vent emitting gas from the rod packing.

(ii) You must measure emissions found in paragraph (b)(2)(i) of this section using a meter or high-volume sampler according to methods set forth in § 60.5386b(b) or (c).

(c) For conducting measurements on manifolded groups of reciprocating compressor affected facilities, you must determine the volumetric flow rate from reciprocating compressor rod packing vent as specified in paragraph (c)(1) and (2) of this section.

(1) Measure at a single point in the manifold downstream of all compressor vent inputs and, if practical, prior to comingling with other non-compressor emission sources.

(2) Determine the volumetric flow rate per cylinder at standard conditions from the common stack using one of the methods specified in paragraph (c)(2)(i) through (iv) of this section.

(i) A temporary or permanent flow meter according to the methods set forth in § 60.5386b(b).

(ii) A high-volume sampler according to methods set forth § 60.5386b(c).

(iii) An alternative method, as set forth in § 60.5386b(d).

(iv) Any of the methods set forth in § 60.5386b(a) to screen for emissions. For the purposes of this paragraph, emissions are detected whenever a leak is detected when using any of the methods in § 60.5386b(a). If emissions are detected using the methods set forth in § 60.5386b(a), then you must use one of the methods specified in paragraph (c)(2)(i) through (iii) of this section to determine the volumetric flow rate per cylinder. If emissions are not detected using the methods in § 60.5386b(a), then you may assume that the volumetric flow rate is zero.

(d) As an alternative to complying with the GHG and VOC standards in paragraphs (a) through (c) of this section, owners or operators can meet the requirements specified in paragraph (d)(1), (2), or (3) of this section.

(1) Collect the methane and VOC emissions from your reciprocating compressor rod packing using a rod packing emissions collection system that is operated to route the rod packing emissions to a process. In order to comply with this option, you must equip the reciprocating compressor with a cover that meets the requirements of § 60.5411b(b). The cover must be connected through a closed vent system that meets the requirements of § 60.5411b(a) and (c).

(2) Reduce methane and VOC emissions from each rod packing emissions collection system by using a control device that reduces methane and VOC emissions by 95.0 percent. In order to comply with this option, you must equip the reciprocating compressor with a cover that meets the requirements of § 60.5411b(b). The cover must be connected through a closed vent system that meets the requirements of § 60.5411b(a) and (c) and the closed vent system must be routed to a control device that meets the conditions specified in § 60.5412b.

(3) As an alternative to conducting the required volumetric flow rate measurements under paragraph (a) of this section, an owner or operator can choose to comply by replacing the rod packing on or before 8,760 hours of operation after initial startup, on or before 8,760 hours of operation after May 7, 2024, on or before 8,760 hours of operation after the previous flow rate measurement, or on or before 8,760 hours of operation after the date of the

most recent compressor rod packing replacement, whichever date is later.

(e) You must demonstrate initial compliance with standards that apply to reciprocating compressor affected facilities as required by § 60.5410b(e).

(f) You must demonstrate continuous compliance with standards that apply to reciprocating compressor affected facilities as required by § 60.5415b(g).

(g) You must perform the reporting requirements as specified in § 60.5420b(b)(1), (6), (11), and (12), as applicable; and the recordkeeping requirements as specified in § 60.5420b(c)(5) and (8) through (13), as applicable.

§ 60.5386b What test methods and procedures must I use for my centrifugal compressor and reciprocating compressor affected facilities?

(a) You must use one of the methods described in paragraph (a)(1) and (2) of this section to screen for emissions or leaks from the reciprocating compressor rod packing when complying with § 60.5385b(b)(1)(iii) and from applicable wet seal centrifugal compressor and dry seal centrifugal compressor vents when complying with § 60.5380b(a)(3) through (6).

(1) *OGI instrument.* Use an OGI instrument for equipment leak detection as specified in either paragraph (a)(1)(i) or (ii) of this section. For the purposes of paragraphs (a)(1)(i) and (ii) of this section, any visible emissions observed by the OGI instrument from reciprocating rod packing or compressor dry seal vent is a leak.

(i) *OGI instrument as specified in appendix K of this part.* For reciprocating compressor, applicable wet seal centrifugal compressor, and dry seal centrifugal compressor affected facilities located at onshore natural gas processing plants, use an OGI instrument to screen for emissions from reciprocating rod packing or centrifugal compressor dry seal vent in accordance with the protocol specified in appendix K of this part.

(ii) *OGI instrument as specified in § 60.5397b of this subpart.* For reciprocating compressor, applicable wet seal centrifugal compressor, and dry seal centrifugal compressor affected facilities located at centralized production facilities, compressor stations, or other location that is not an onshore natural gas processing plant, use an OGI instrument to screen for emissions from reciprocating rod packing or compressor dry seals in accordance with the elements of § 60.5397b(c)(7).

(2) *Method 21.* Use Method 21 in appendix A-7 to this part according to

§ 60.5403b(b)(1) and (2). For the purposes of this section, an instrument reading of 500 parts per million by volume (ppmv) above background or greater is a leak.

(b) You must determine natural gas volumetric flow rate using a rate meter which meets the requirement in Method 2D in appendix A-1 of this part. Rate meters must be calibrated on an annual basis according to the requirements in Method 2D.

(c) You must use a high-volume sampler to measure emissions of the reciprocating compressor rod packing, applicable centrifugal compressor wet seal vent, or centrifugal compressor dry seal vent in accordance with paragraphs (c)(1) through (7) of this section.

(1) You must use a high-volume sampler designed to capture the entirety of the emissions from the applicable vent and measure the entire range of methane concentrations being emitted as well as the total volumetric flow at standard conditions. You must develop a standard operating procedure for this device and document these procedures in the appropriate monitoring plan. In order to get reliable results, persons using this device should be knowledgeable in its operation and the requirements in this section.

(2) This procedure may involve hazardous materials, operations, and equipment. This procedure may not address all of the safety problems associated with its use. It is the responsibility of the user of this procedure to establish appropriate safety and health practices and determine the applicability of regulatory limitations prior to performing this procedure.

(3) The high-volume sampler must include a methane gas sensor(s) which meets the requirements in paragraphs (c)(3)(i) through (iii) of this section.

(i) The methane sensor(s) must be selective to methane with minimal interference, less than 2.5 percent for the sum of responses to other compounds in the gas matrix. You must document the minimal interference through empirical testing or through data provided by the manufacturer of the sensor.

(ii) The methane sensor(s) must have a measurement range over the entire expected range of concentrations.

(iii) The methane sensor(s) must be capable of taking a measurement once every second, and the data system must be capable of recording these results for each sensor at all times during operation of the sampler.

(4) The high-volume sampler must be designed such that it is capable of sampling sufficient volume in order to

capture all emissions from the applicable vent. Your high-volume sampler must include a flow measurement sensor(s) which meets the requirements of paragraphs (c)(4)(i) and (ii) of this section.

(i) The flow measurement sensor must have a measurement range over the entire expected range of flow rates sampled. If needed multiple sensors may be used to capture the entire range of expected flow rates.

(ii) The flow measurement sensor(s) must be capable of taking a measurement once every second, and the data system must be capable of recording these results for each sensor at all times during operation of the sampler.

(5) You must calibrate your methane sensor(s) according to the procedures in paragraphs (c)(5)(i)(A) and (B) of this section, and flow measurement sensors must be calibrated according to the procedures in paragraph (c)(5)(ii) of this section.

(i) For Methane Sensor Calibration:

(A) Initially and on a semi-annual basis, determine the linearity at four points through the measurement range for each methane sensor using methane gaseous calibration cylinder standards. At each point, the difference between the cylinder value and the sensor reading must be less than 5 percent of the respective calibration gas value. If the sensor does not meet this requirement, perform corrective action on the sensor, and do not use the sampler until these criteria can be met.

(B) Prior to and at the end of each testing day, challenge each sensor at two points, a low point, and a mid-point, using methane gaseous calibration cylinder standards. At each point, the difference between the cylinder value and the sensor reading must be less than 5 percent of the respective calibration gas value. If the sensor does not meet this requirement, perform corrective action on the sensor and do not use the sampler again until these criteria can be met. If the post-test calibration check fails at either point, invalidate the data from all tests performed subsequent to the last passing calibration check.

(ii) Flow measurement sensors must meet the requirements in Method 2D in appendix A-1 of this part. Rate meters must be calibrated on an annual basis according to the requirements in Method 2D. If your flow sensor relies on ancillary temperature and pressure measurements to correct the flow rate to standard conditions, the temperature and pressure sensors must also be calibrated on an annual basis. Standard conditions are defined as 20 °C (68 °F) and 760 mm Hg (29.92 in. Hg).

(6) You must conduct sampling of the reciprocating compressor rod packing, applicable wet seal centrifugal compressor, or dry seal centrifugal compressor vent in accordance with the procedures in paragraphs (c)(6)(i) through (v) of this section.

(i) The instrument must be operated consistent with manufacturer recommendations; users are encouraged to develop a standard operating procedure to document the exact procedures used for sampling.

(ii) Identify the rod packing, applicable wet seal centrifugal compressor, or dry seal centrifugal compressor vent to be measured and record the signal to noise ratio (S/N) of the engine. Collect a background methane sample in ppmv for a minimum of one minute and record the result along with the date and time.

(iii) Approach the vent with the sample hose and adjust the sampler so that you are measuring at the full flow rate. Then, adjust the flow rate to ensure the measured methane concentration is

within the calibrated range of the methane sensor and minimum methane concentration is at least 2 ppmv higher than the background concentration. Sample for a period of at least one minute and record the average flow rate in standard cubic feet per minute and the methane sample concentration in ppmv, along with the date and time. Standard conditions are defined as 20 °C (68 °F) and 760 mm Hg (29.92 in. Hg).

(iv) Calculate the leak rate according to the following equation:

Equation 1 to paragraph (c)(6)(iv)

$$Q = V \left(\frac{CH4_S - CH4_B}{1000000} \right)$$

Where:

CH_{4B} = background methane concentration, ppmv

CH_{4S} = methane sample concentration, ppmv

V = Average flow rate of the sampler, scfm

Q = Methane emission rate, scfm

(v) You must collect at least three separate one-minute measurements and determine the average leak rate. The relative percent difference of these three separate samples should be less than 10 percent.

(7) If the measured natural gas flow determined as specified in paragraph (c)(6) of this section exceeds 70.0 percent of the manufacturer's reported maximum sampling flow rate you must either use a temporary or permanent flow meter according to paragraph (b) of this section or use another method meeting the requirements in paragraph (d) of this section to determine the leak or flow rate.

(d) As an alternative to a high-volume sampler, you may use any other method that has been validated in accordance with the procedures specified in Method 301 in appendix A in 40 CFR part 63, subject to Administrator approval, as specified in § 60.8(b).

§ 60.5390b What GHG and VOC standards apply to process controller affected facilities?

Each process controller affected facility must comply with the GHG and VOC standards in this section.

(a) You must design and operate each process controller affected facility with zero methane and VOC emissions to the atmosphere, except as provided in paragraph (b) of this section.

(1) If you comply by routing the emissions to a process, emissions must be routed to a process through a closed vent system.

(2) If you comply by using a self-contained natural gas-driven process controller, you must design and operate each self-contained natural gas-driven process controller with no identifiable emissions, as demonstrated by § 60.5416b(b).

(b) For each process controller affected facility located at a site in Alaska that does not have access to electrical power, you may comply with either paragraphs (b)(1) and (2) of this section or with paragraph (b)(3) of this section, instead of complying with paragraph (a) of this section.

(1) With the exception of natural gas-driven continuous bleed controllers that meet the condition in paragraph (b)(1)(i) of this section and that comply with paragraph (b)(1)(ii) of this section, each natural gas-driven continuous bleed process controller in the process controller affected facility must have a bleed rate less than or equal to 6 standard cubic feet per hour (scfh).

(i) A natural gas-driven continuous bleed process controller with a bleed rate higher than 6 scfh may be used if the requirements of paragraph (b)(1)(ii) of this section are met.

(ii) You demonstrate that a natural gas-driven continuous bleed controller with a bleed rate higher than 6 scfh is required. The demonstration must be based on the specific functional need, including but not limited to response time, safety, or positive actuation.

(2) Each natural gas-driven intermittent vent process controller in the process controller affected facility must comply with the requirements in paragraphs (b)(2)(i) and (ii) of this section.

(i) Each natural gas-driven intermittent vent process controller

must not emit to the atmosphere during idle periods.

(ii) You must monitor each natural gas-driven intermittent vent process controller to ensure that it is not emitting to the atmosphere during idle periods, as specified in paragraphs (b)(2)(ii)(A) through (C) of this section.

(A) Monitoring must be conducted at the same frequency as specified for fugitive emissions components affected facilities located at the same type of site, as specified in § 60.5397b(g).

(B) You must include the monitoring of each natural gas-driven intermittent vent process controller in the monitoring plan required in § 60.5397b(b).

(C) When monitoring identifies emissions to the atmosphere from a natural gas-driven intermittent vent controller during idle periods, you must take corrective action by repairing or replacing the natural gas-driven intermittent vent process controller within 5 calendar days of the date the emissions to the atmosphere were detected. After the repair or replacement of a natural gas-driven intermittent vent process controller, you must re-survey the natural gas-driven intermittent vent process controller within five days to verify that it is not venting emissions during idle periods.

(3) You must reduce methane and VOC emissions from all controllers in the process controller affected facility by 95.0 percent. You must route emissions through a closed vent system to a control device that meets the conditions specified in § 60.5412b.

(c) If you route process controller emissions to a process or a control device, you must route the process controller affected facility emissions through a closed vent system that meets

the requirements of § 60.5411b(a) and (c).

(d) You must demonstrate initial compliance with standards that apply to process controller affected facilities as required by § 60.5410b(f).

(e) You must demonstrate continuous compliance with standards that apply to process controller affected facilities as required by § 60.5415b(h).

(f) You must perform the reporting as required by § 60.5420b(b)(1), (7), and (11) through (13), as applicable, and the recordkeeping as required by § 60.5420b(c)(6), (8), and (10) through (13), as applicable.

§ 60.5393b What GHG and VOC standards apply to pump affected facilities?

Each pump affected facility must comply with the GHG and VOC standards in this section.

(a) For each pump affected facility meeting the criteria specified in paragraphs (a)(1) or (2) of this section, you must design and operate the pump affected facility with zero methane and VOC emissions to the atmosphere. If you comply by routing the pump affected facility emissions to a process, the emissions must be routed to the process through a closed vent system.

(1) The pump affected facility is located at a site that has access to electrical power.

(2) The pump affected facility is located at a site that does not have access to electrical power and has three or more natural gas-driven diaphragm pumps.

(b)(1) For each pump affected facility located at a site that does not have access to electrical power and that also has fewer than three natural gas-driven diaphragm pumps, you must comply with paragraph (b)(2) or (3) of this section, except as provided in paragraphs (b)(4) through (8) of this section.

(2) Emissions from the pump affected facility must be routed through a closed vent system to a process if a vapor recovery unit is onsite.

(3) If a vapor recovery unit is not onsite, you must reduce methane and VOC emissions from the pump affected facility by 95.0 percent. You must route affected pump facility emissions through a closed vent system to a control device meeting the conditions specified in § 60.5412b.

(4) You are not required to install an emissions control device or a vapor recovery unit, if such a unit is necessary to enable emissions to be routed to a process, solely for the purpose of complying with the requirements of paragraph (b)(2) or (3) of this section. If no control device capable of achieving

a 95.0 percent emissions reduction and no vapor recovery unit is present on site, you must comply with paragraph (b)(5) or (6) of this section, as applicable. For the purposes of this section, boilers and process heaters are not considered to be control devices.

(5) If an emissions control device is on site but is unable to achieve a 95.0 percent emissions reduction, you must route the pump affected facility emissions through a closed vent system to that control device. You must certify that there is no vapor recovery unit on site and that there is no control device capable of achieving a 95.0 percent emissions reduction on site.

(6) If there is no vapor recovery unit on site and no emission control device is on site, you must certify that there is no vapor recovery unit or emissions control device on site. If you subsequently install a control device or vapor recovery unit, you must meet the requirements of paragraphs (b)(6)(i) and (ii) of this section.

(i) You must be in compliance with the requirements of paragraphs (b)(1) through (3) of this section, as applicable, within 30 days of startup of the control device or vapor recovery unit.

(ii) You must maintain the records in § 60.5420b(c)(15)(ii) and (v), as applicable. You are no longer required to maintain the records in § 60.5420b(c)(15)(vi).

(7) If an owner or operator complying with paragraph (b)(1) of this section determines, through an engineering assessment, that routing the pump affected facility emissions to a control device or to a process is technically infeasible, the requirements specified in paragraphs (b)(7)(i) through (iii) of this section must be met.

(i) The owner or operator must conduct the assessment of technical infeasibility in accordance with the criteria in paragraph (b)(7)(ii) of this section and have it certified by either a qualified professional engineer or an in-house engineer with expertise on the design and operation of the pump affected facility and the control device or processes at the site in accordance with paragraph (b)(7)(iii) of this section.

(ii) The assessment of technical infeasibility to route emissions from the pump affected facility to an existing control device or process must include, but is not limited to, safety considerations, distance from the control device or process, pressure losses and differentials in the closed vent system, and the ability of the control device or process to handle the pump affected facility emissions which are routed to them. The assessment of technical infeasibility must be prepared

under the direction or supervision of the qualified professional engineer or in-house engineer who signs the certification in accordance with paragraph (b)(7)(iii) of this section.

(iii) The following certification, signed and dated by the qualified professional engineer or in-house engineer, must state: "I certify that the assessment of technical infeasibility was prepared under my direction or supervision. I further certify that the assessment was conducted and this report was prepared pursuant to the requirements of § 60.5393b(b)(5)(ii). Based on my professional knowledge and experience, and inquiry of personnel involved in the assessment, the certification submitted herein is true, accurate, and complete."

(8) If the pump affected facility emissions are routed to a control device or process and the control device or process is subsequently removed from the location or is no longer available, such that there is no option to route to a control device or process, you are no longer required to be in compliance with the requirements of paragraphs (b)(2) or (3) of this section, and instead must comply with paragraph (b)(6) of this section.

(c) If you use a control device or route to a process to reduce emissions, you must route the pump affected facility emissions through a closed vent system that meets the requirements of § 60.5411b(a) and (c).

(d) You must demonstrate initial compliance with standards that apply to pump affected facilities as required by § 60.5410b(g).

(e) You must demonstrate continuous compliance with the standards that apply to pump affected facilities as required by § 60.5415b(e).

(f) You must perform the reporting as required by § 60.5420b(b)(1), (10), and (11) through (13), as applicable; and the recordkeeping as required by § 60.5420b(c)(8), (10) through (13), and (15), as applicable.

§ 60.5395b What GHG and VOC standards apply to storage vessel affected facilities?

Each storage vessel affected facility must comply with the GHG and VOC standards in this section, except as provided in paragraph (e) of this section.

(a) *General requirements.* You must comply with the requirements of paragraphs (a)(1) and (2) of this section. After 12 consecutive months of compliance with paragraph (a)(2) of this section, you may continue to comply with paragraph (a)(2) of this section, or you may comply with paragraph (a)(3) of this section, if applicable. If you

choose to meet the requirements of paragraph (a)(3) of this section, you are not required to comply with the requirements of paragraph (a)(2) of this section except as provided in paragraphs (a)(3)(i) and (ii) of this section.

(1) Determine the potential for methane and VOC emissions in accordance with § 60.5365b(e)(2).

(2) Reduce methane and VOC emissions by 95.0 percent.

(3) Maintain the uncontrolled actual VOC emissions at less than 4 tpy and the actual methane emissions at less than 14 tpy from the storage vessel affected facility without considering control. Prior to using the uncontrolled actual VOC and methane emission rates for compliance purposes, you must demonstrate that the uncontrolled actual VOC emissions have remained less than 4 tpy and the uncontrolled actual methane emissions have remained less than 14 tpy as determined monthly for 12 consecutive months. After such demonstration, you must determine the uncontrolled actual rolling 12-month determination VOC and methane emissions rates each month. The uncontrolled actual VOC and methane emissions must be calculated using a generally accepted model or calculation methodology which account for flashing, working and breathing losses, and the calculations must be based on the actual average throughput, temperature, and separator pressure for the month. You may no longer comply with this paragraph and must instead comply with paragraph (a)(2) of this section if your storage vessel affected facility meets the conditions specified in paragraphs (a)(3)(i) or (ii) of this section.

(i) If a well feeding the storage vessel affected facility undergoes fracturing or refracturing, you must comply with paragraph (a)(2) of this section as soon as liquids from the well following fracturing or refracturing are routed to the storage vessel affected facility.

(ii) If the rolling 12-month emissions determination required in this section indicates that VOC emissions increase to 4 tpy or greater or the methane emissions increase to 14 tpy or greater from your storage vessel affected facility and the increase is not associated with fracturing or refracturing of a well feeding the storage vessel affected facility, you must comply with paragraph (a)(2) of this section within 30 days of the monthly determination.

(b) *Control requirements.* (1) Except as required in paragraph (b)(2) of this section, if you use a control device to reduce methane and VOC emissions from your storage vessel affected

facility, you must meet all of the design and operational criteria specified in paragraphs (b)(1)(i) through (iii) of this section.

(i) Each storage vessel in the tank battery must be equipped with a cover that meets the requirements of § 60.5411b(b);

(ii) The tank battery must be equipped with one or more closed vent system that meets the requirements of § 60.5411b(a) and (c); and

(iii) The vapors collected in paragraphs (b)(1)(ii) of this section must be routed to a control device that meets the conditions specified in § 60.5412b. As an alternative to routing the closed vent system to a control device, you may route the closed vent system to a process.

(2) For storage vessel affected facilities that do not have flashing emissions and that are not located at well sites or centralized production facilities, you may use a floating roof to reduce emissions. If you use a floating roof to reduce emissions, you must meet the requirements of § 60.112b(a)(1) or (2) and the relevant monitoring, inspection, recordkeeping, and reporting requirements in subpart Kb of this part. You must submit a statement that you are complying with § 60.112b(a)(1) or (2) with the initial annual report specified in § 60.5420b(b)(1) and (8).

(c) *Requirements for storage vessel affected facilities that are removed from service or returned to service.* If you remove a storage vessel affected facility from service or remove a portion of a storage vessel affected facility from service, you must comply with the applicable paragraphs (c)(1) through (4) of this section. A storage vessel is not an affected facility under this subpart for the period that it is removed from service.

(1) For a storage vessel affected facility to be removed from service, you must comply with the requirements of paragraphs (c)(1)(i) and (ii) of this section.

(i) You must completely empty and degas each storage vessel, such that each storage vessel no longer contains crude oil, condensate, produced water or intermediate hydrocarbon liquids. A storage vessel where liquid is left on walls, as bottom clingage or in pools due to floor irregularity is considered to be completely empty.

(ii) You must submit a notification as required in § 60.5420b(b)(6)(viii) in your next annual report, identifying each storage vessel affected facility removed from service during the reporting period and the date of its removal from service.

(2) For a portion of a storage vessel affected facility to be removed from

service, you must comply with the requirements of paragraphs (c)(2)(i) through (iv) of this section.

(i) You must completely empty and degas the storage vessel(s), such that the storage vessel(s) no longer contains crude oil, condensate, produced water or intermediate hydrocarbon liquids. A storage vessel where liquid is left on walls, as bottom clingage or in pools due to floor irregularity is considered to be completely empty.

(ii) You must disconnect the storage vessel(s) from the tank battery by isolating the storage vessel(s) from the tank battery such that the storage vessel(s) is no longer manifolded to the tank battery by liquid or vapor transfer.

(iii) You must submit a notification as required in § 60.5420b(b)(8)(viii) in your next annual report, identifying each storage vessel removed from service during the reporting period, the impacted storage vessel affected facility, and the date of its removal from service.

(iv) The remaining storage vessel(s) in the tank battery remain a storage vessel affected facility and must continue to comply with the applicable requirements of paragraphs (a) and (b) of this section.

(3) If a storage vessel identified in paragraph (c)(1)(ii) or (c)(2)(iii) of this section is returned to service, you must determine its affected facility status as provided in § 60.5365b(e)(6).

(4) For each storage vessel affected facility or portion of a storage vessel affected facility returned to service during the reporting period, you must submit a notification in your next annual report as required in § 60.5420b(b)(8)(ix), identifying each storage vessel affected facility or portion of a storage vessel affected facility and the date of its return to service.

(d) *Compliance, notification, recordkeeping, and reporting.* You must comply with paragraphs (d)(1) through (3) of this section.

(1) You must demonstrate initial compliance with standards as required by § 60.5410b(j).

(2) You must demonstrate continuous compliance with standards as required by § 60.5415b(i).

(3) You must perform the required reporting as required by § 60.5420b(b)(1) and (8) and (b)(11) through (13), as applicable; and the recordkeeping as required by § 60.5420b(c)(7) and (c)(8) through (13), as applicable.

(e) *Exemptions.* This subpart does not apply to storage vessels subject to and controlled in accordance with the requirements for storage vessels in subpart Kb of this part, and 40 CFR part 63, subparts G, CC, HH, or WW.

§ 60.5397b What GHG and VOC standards apply to fugitive emissions components affected facilities?

This section applies to fugitive emissions components affected facilities. You must comply with the requirements of paragraphs (a) through (l) of this section to reduce fugitive emissions of methane and VOC. The requirements of this section are independent of the cover and closed vent system requirements of § 60.5411b.

(a) *General requirements.* You must monitor all fugitive emissions components affected facilities in accordance with paragraphs (b) through (g) of this section. You must repair all sources of fugitive emissions in accordance with paragraph (h) of this section. You must demonstrate initial compliance in accordance with paragraph (i) of this section. You must keep records in accordance with paragraph (j) of this section and report in accordance with paragraph (k) of this section. You must meet the requirements for well closures in accordance with paragraph (l) of this section.

(b) *Develop fugitive emissions monitoring plan.* You must develop a fugitive emissions monitoring plan that covers all fugitive emissions components affected facilities within each company-defined area in accordance with paragraphs (c) and (d) of this section.

(c) *Elements of fugitive emissions monitoring plan.* Your fugitive emissions monitoring plan must include the elements specified in paragraphs (c)(1) through (8) of this section, at a minimum.

(1) Frequency for conducting surveys. Surveys must be conducted at least as frequently as required by paragraphs (f) and (g) of this section.

(2) Technique for determining fugitive emissions (*i.e.*, AVO or other detection methods, Method 21 of appendix A-7 to this part, and/or OGI and meeting the requirements of paragraphs (c)(7)(i) through (vii) of this section).

(3) Manufacturer and model number of fugitive emissions detection equipment to be used, if applicable.

(4) Procedures and timeframes for identifying and repairing fugitive emissions components from which fugitive emissions are detected, including timeframes for fugitive emission components that are unsafe to repair. Your repair schedule must meet the requirements of paragraph (h) of this section at a minimum.

(5) Procedures and timeframes for verifying fugitive emission component repairs.

(6) Records that will be kept and the length of time records will be kept.

(7) If you are using OGI, your plan must also include the elements specified in paragraphs (c)(7)(i) through (vii) of this section.

(i) Verification that your OGI equipment meets the specifications of paragraphs (c)(7)(i)(A) and (B) of this section. This verification is an initial verification, and may either be performed by the facility, by the manufacturer, or by a third party. For the purposes of complying with the fugitive emissions monitoring program with OGI, fugitive emissions are defined as any visible emissions observed using OGI.

(A) Your OGI equipment must be capable of imaging gases in the spectral range for the compound of highest concentration in the potential fugitive emissions.

(B) Your OGI equipment must be capable of imaging a gas that is half methane, half propane at a concentration of 10,000 ppm at a flow rate of ≤60 g/hr from a quarter inch diameter orifice.

(ii) Procedure for a daily verification check.

(iii) Procedure for determining the operator's maximum viewing distance from the equipment and how the operator will ensure that this distance is maintained.

(iv) Procedure for determining maximum wind speed during which monitoring can be performed and how the operator will ensure monitoring occurs only at wind speeds below this threshold.

(v) Procedures for conducting surveys, including the items specified in paragraphs (c)(7)(v)(A) through (C) of this section.

(A) How the operator will ensure an adequate thermal background is present in order to view potential fugitive emissions.

(B) How the operator will deal with adverse monitoring conditions, such as wind.

(C) How the operator will deal with interferences (*e.g.*, steam).

(vi) Training and experience needed prior to performing surveys.

(vii) Procedures for calibration and maintenance. At a minimum, procedures must comply with those recommended by the manufacturer.

(8) If you are using Method 21 of appendix A-7 to this part, your plan must also include the elements specified in paragraphs (c)(8)(i) through (iv) of this section. For the purposes of complying with the fugitive emissions monitoring program using Method 21 of appendix A-7 to this part a fugitive

emission is defined as an instrument reading of 500 ppmv or greater.

(i) *Verification that your monitoring equipment meets the requirements specified in Section 6.0 of Method 21 of appendix A-7 to this part.* For purposes of instrument capability, the fugitive emissions definition shall be 500 ppmv or greater methane using a FID-based instrument. If you wish to use an analyzer other than an FID-based instrument, you must develop a site-specific fugitive emission definition that would be equivalent to 500 ppmv methane using a FID-based instrument (*e.g.*, 10.6 eV PID with a specified isobutylene concentration as the fugitive emission definition would provide equivalent response to your compound of interest).

(ii) *Procedures for conducting surveys.* At a minimum, the procedures shall ensure that the surveys comply with the relevant sections of Method 21 of appendix A-7 to this part, including Section 8.3.1.

(iii) *Procedures for calibration.* The instrument must be calibrated before use each day of its use by the procedures specified in Method 21 of appendix A-7 to this part. At a minimum, you must also conduct precision tests at the interval specified in Method 21 of appendix A-7 to this part, Section 8.1.2, and a calibration drift assessment at the end of each monitoring day. The calibration drift assessment must be conducted as specified in paragraph (c)(8)(iii)(A) of this section. Corrective action for drift assessments is specified in paragraphs (c)(8)(iii)(B) and (C) of this section.

(A) Check the instrument using the same calibration gas that was used to calibrate the instrument before use. Follow the procedures specified in Method 21 of appendix A-7 to this part, Section 10.1, except do not adjust the meter readout to correspond to the calibration gas value. If multiple scales are used, record the instrument reading for each scale used. Divide the arithmetic difference of the initial and post-test calibration response by the corresponding calibration gas value for each scale and multiply by 100 to express the calibration drift as a percentage.

(B) If a calibration drift assessment shows a negative drift of more than 10 percent, then all equipment with instrument readings between the fugitive emission definition multiplied by (100 minus the percent of negative drift) divided by 100 and the fugitive emission definition that was monitored since the last calibration must be re-monitored.

(C) If any calibration drift assessment shows a positive drift of more than 10 percent from the initial calibration value, then, at the owner/operator's discretion, all equipment with instrument readings above the fugitive emission definition and below the fugitive emission definition multiplied by 100 plus the percent of positive drift) divided by 100 monitored since the last calibration may be re-monitored.

(iv) *Procedures for monitoring yard piping (other than buried yard piping).* At a minimum, place the probe inlet at the surface of the yard piping and run the probe down the length of the piping. Connection points on the piping must be monitored following the procedures specified in Method 21 of appendix A-7 to this part.

(d) *Additional elements of fugitive emissions monitoring plan.* Each fugitive emissions monitoring plan must include the elements specified in paragraphs (d)(1) through (3) of this section, at a minimum, as applicable.

(1) If you are using OGI, your plan must include procedures to ensure that all fugitive emissions components, except buried yard piping and associated components (e.g., connectors), are monitored during each survey. Example procedures include, but are not limited to, a sitemap with an observation path, a written narrative of where the fugitive emissions components are located and how they will be monitored, or an inventory of fugitive emissions components.

(2) If you are using Method 21 of appendix A-7 to this part, your plan must include a list of fugitive emissions components to be monitored and method for determining the location of fugitive emissions components to be monitored in the field (e.g., tagging, identification on a process and instrumentation diagram, etc.). Your fugitive emissions monitoring plan must include the written plan developed for all of the fugitive emissions components designated as difficult-to-monitor in accordance with paragraph (g)(2) of this section, and the written plan for fugitive emissions components designated as unsafe-to-monitor in accordance with paragraph (g)(3) of this section.

(e) *Monitoring of fugitive emissions components.* Each fugitive emissions component, except buried yard piping and associated components (e.g., connectors), shall be observed or monitored for fugitive emissions during each monitoring survey.

(f) *Initial monitoring survey.* You must conduct initial monitoring surveys according to the requirements specified in paragraphs (f)(1) through (4) of this section.

(1) At single wellhead only sites and small sites, you must conduct an initial monitoring survey using audible, visual, and olfactory (AVO), or any other detection methods (e.g., OGI), within 90 days of the startup of production, for each fugitive emissions components affected facility or by June 6, 2024 whichever date is later.

(2) For multi-wellhead only well sites, well sites or centralized production facilities that contain the major production and processing equipment specified in paragraphs (g)(1)(iv)(A), (B), (C), or (D) of this section, and compressor station sites, you must conduct an initial monitoring survey using OGI or Method 21 of appendix A-7 to this part within 90 days of the startup of production, for each fugitive emissions components affected facility or by June 6, 2024 whichever date is later.

(3) For a modified or reconstructed fugitive emissions components affected facility, the initial monitoring survey must be conducted within 90 days of the startup of production for each fugitive emissions components affected facility after the modification or reconstruction or by June 6, 2024, whichever date is later.

(4) Notwithstanding the deadlines specified in paragraphs (f)(1) through (3) of this section, for each fugitive emissions components affected facility located on the Alaskan North Slope that starts up production between September and March, you must conduct an initial monitoring survey within 6 months of the startup of production for a new well site, within 6 months of the first day of production after a modification of the fugitive emissions components affected facility, or by the following June 30, whichever date is latest.

(g) *Monitoring frequency.* A monitoring survey of each fugitive emissions components affected facility must be performed as specified in paragraph (g)(1) of this section, with the exceptions noted in paragraphs (g)(2) through (4) of this section. Monitoring for fugitive emissions components affected facilities located at well sites and centralized production facilities that have wells located onsite must continue at the specified frequencies in paragraphs (g)(1)(i), (ii), (iii), (iv) and (vi) of this section until the well closure requirements of paragraph (l) of this section are completed.

(1) A monitoring survey of the fugitive emissions components affected facilities must be conducted using the methods and at the frequencies specified in paragraphs (g)(1)(i) through (vi) of this section.

(i) A monitoring survey of the fugitive emissions component affected facilities located at single wellhead only well sites must be conducted at least quarterly using AVO, or any other detection method, after the initial survey except as specified in paragraph (g)(1)(vi) of this section. Any indications of fugitive emissions using these methods are considered fugitive emissions that must be repaired in accordance with paragraph (h) of this section.

(ii) A monitoring survey of the fugitive emissions component affected facilities located at small well sites must be conducted at least quarterly using AVO, or any other detection method, after the initial survey except as specified in paragraph (g)(1)(vi) of this section. Any indications of fugitive emissions using these methods are considered fugitive emissions that must be repaired in accordance with paragraph (h) of this section. At small well sites with an uncontrolled storage vessel, a visual inspection of all thief hatches and other openings on the storage vessel that are fugitive emissions components must be conducted in conjunction with the monitoring survey to ensure that they are kept closed and sealed at all times except during times of adding or removing material, inspecting or sampling material, or during required maintenance operations. If evidence of a deviation from this requirement is found, you must take corrective action. At small well sites with a separator, a visual inspection of all separator dump valves to ensure the dump valve is free of debris and not stuck in an open position must be conducted in conjunction with the monitoring survey. Any dump valve not operating as designed must be repaired.

(iii) A monitoring survey of the fugitive emissions components affected facilities located at multi-wellhead only well sites must be conducted in accordance with paragraphs (g)(1)(iii)(A) and (B) of this section, except as specified in paragraph (g)(1)(vi) of this section.

(A) A monitoring survey must be conducted at least quarterly using AVO, or any other detection method, after the initial survey. Any indications of fugitive emissions using these methods are considered fugitive emissions that must be repaired in accordance with paragraph (h) of this section.

(B) A monitoring survey must be conducted at least semiannually using OGI or Method 21 of appendix A-7 to this part after the initial survey. Consecutive semiannual surveys must

be conducted at least 4 months apart and no more than 7 months apart.

(iv) A monitoring survey of the fugitive emissions components affected facilities located at well sites or centralized production facilities that contain the major production and processing equipment specified in paragraphs (g)(1)(iv)(A), (B), (C), or (D) must be conducted at the frequencies in paragraphs (g)(1)(iv)(E) and (F) of this section, except as specified in paragraph (g)(1)(vi) of this section.

(A) One or more controlled storage vessels or tank batteries.

(B) One or more control devices.

(C) One or more natural gas-driven process controllers or pumps.

(D) Two or more pieces of major production and processing equipment not specified in paragraphs (g)(1)(iv)(A) through (C) of this section.

(E) A monitoring survey must be conducted at least bimonthly using AVO, or any other detection method, after the initial survey. Any indications of fugitive emissions using these methods are considered fugitive emissions that must be repaired in accordance with paragraph (h) of this section. A visual inspection of all thief hatches and other openings on storage vessels (or tank batteries) that are fugitive emissions components must be conducted in conjunction with the monitoring survey to ensure that they are kept closed and sealed at all times except during times of adding or removing material, inspecting or sampling material, or during required maintenance operations. If evidence of a deviation from this requirement is found, you must take corrective action. A visual inspection must be conducted of all separator dump valves to ensure the dump valve is free of debris and not stuck in an open position must be conducted in conjunction with the monitoring survey. Any dump valve not operating as designed must be repaired.

(F) A monitoring survey must be conducted at least quarterly using OGI or Method 21 of appendix A-7 to this part after the initial survey. Consecutive quarterly monitoring surveys must be conducted at least 60 calendar days apart.

(v) A monitoring survey of the fugitive emissions components affected facility located at a compressor station must be conducted at the frequencies in paragraphs (g)(1)(v)(A) and (B) of this section, except as specified in paragraph (g)(1)(vi) of this section.

(A) A monitoring survey must be conducted at least monthly using AVO, or any other detection method, after the initial survey. Any indications of fugitive emissions using these methods

are considered fugitive emissions that must be repaired in accordance with paragraph (h) of this section.

(B) A monitoring survey must be conducted at least quarterly using OGI or Method 21 of appendix A-7 to this part after the initial survey. Consecutive quarterly monitoring surveys must be conducted at least 60 calendar days apart.

(vi) A monitoring survey of the fugitive emissions components affected facility located on the Alaska North Slope must be conducted using OGI of this part or Method 21 of appendix A-7 to this part at least annually. Consecutive annual monitoring surveys must be conducted at least 9 months apart and no more than 13 months apart.

(2) If you are using Method 21 of appendix A-7 to this part, fugitive emissions components that cannot be monitored without elevating the monitoring personnel more than 2 meters above the surface may be designated as difficult-to-monitor. Fugitive emissions components that are designated difficult-to-monitor must meet the specifications of paragraphs (g)(2)(i) through (iv) of this section.

(i) A written plan must be developed for all the fugitive emissions components designated difficult-to-monitor. This written plan must be incorporated into the fugitive emissions monitoring plan required by paragraphs (b), (c), and (d) of this section.

(ii) The plan must include the identification and location of each fugitive emissions component designated as difficult-to-monitor.

(iii) The plan must include an explanation of why each fugitive emissions component designated as difficult-to-monitor is difficult-to-monitor.

(iv) The plan must include a schedule for monitoring the difficult-to-monitor fugitive emissions components at least once per calendar year.

(3) If you are using Method 21 of appendix A-7 to this part, fugitive emissions components that cannot be monitored because monitoring personnel would be exposed to immediate danger while conducting a monitoring survey may be designated as unsafe-to-monitor. Fugitive emissions components that are designated unsafe-to-monitor must meet the specifications of paragraphs (g)(3)(i) through (iv) of this section.

(i) A written plan must be developed for all the fugitive emissions components designated unsafe-to-monitor. This written plan must be incorporated into the fugitive emissions

monitoring plan required by paragraphs (b), (c), and (d) of this section.

(ii) The plan must include the identification and location of each fugitive emissions component designated as unsafe-to-monitor.

(iii) The plan must include an explanation of why each fugitive emissions component designated as unsafe-to-monitor is unsafe-to-monitor.

(iv) The plan must include a schedule for monitoring the fugitive emissions components designated as unsafe-to-monitor.

(4) The requirements of paragraphs (g)(1)(iv)(F) and (g)(1)(v)(B) of this section are waived during a quarterly monitoring period for any fugitive emissions components affected facility located within an area that has an average calendar month temperature below 0 degrees Fahrenheit for two of three consecutive calendar months of a quarterly monitoring period. The calendar month temperature average for each month within the quarterly monitoring period must be determined using historical monthly average temperatures over the previous three years as reported by a National Oceanic and Atmospheric Administration source or other source approved by the Administrator. The requirements of paragraph (g)(1)(iv) and (v) of this section shall not be waived for two consecutive quarterly monitoring periods.

(h) *Repairs.* Each identified source of fugitive emissions shall be repaired in accordance with paragraphs (h)(1) and (2) of this section.

(1) A first attempt at repair shall be made in accordance with paragraphs (h)(1)(i) and (ii) of this section.

(i) A first attempt at repair shall be made no later than 15 calendar days after detection of fugitive emissions that were identified using AVO.

(ii) If you are complying with paragraph (g)(1)(i) through (vi) of this section using OGI or Method 21 of appendix A-7 to this part, a first attempt at repair shall be made no later than 30 calendar days after detection of the fugitive emissions.

(2) Repair shall be completed as soon as practicable, but no later than 15 calendar days after the first attempt at repair as required in paragraph (h)(1)(i) of this section, and 30 calendar days after the first attempt at repair as required in paragraph (h)(1)(ii) of this section.

(3) Delay of repair will be allowed if the conditions in paragraphs (h)(3)(i) or (ii) of this section are met.

(i) If the repair is technically infeasible, would require a vent blowdown, a compressor station

shutdown, a well shutdown or well shut-in, or would be unsafe to repair during operation of the unit, the repair must be completed during the next scheduled compressor station shutdown for maintenance, scheduled well shutdown, scheduled well shut-in, after a scheduled vent blowdown, or within 2 years of detecting the fugitive emissions, whichever is earliest. A vent blowdown is the opening of one or more blowdown valves to depressurize major production and processing equipment, other than a storage vessel.

(ii) If the repair requires replacement of a fugitive emissions component or a part thereof, but the replacement cannot be acquired and installed within the repair timelines specified in paragraphs (h)(1) and (2) of this section due to either of the conditions specified in paragraph (h)(3)(ii)(A) or (B) of this section, the repair must be completed in accordance with paragraph (h)(3)(ii)(C) of this section and documented in accordance with § 60.5420b(c)(14)(v)(I).

(A) Valve assembly supplies had been sufficiently stocked but are depleted at the time of the required repair.

(B) A replacement fugitive emissions component or a part thereof requires custom fabrication.

(C) The required replacement must be ordered no later than 10 calendar days after the first attempt at repair. The repair must be completed as soon as practicable, but no later than 30 calendar days after receipt of the replacement component, unless the repair requires a compressor station or well shutdown. If the repair requires a compressor station or well shutdown, the repair must be completed in accordance with the timeframe specified in paragraph (h)(3)(i) of this section.

(4) Each identified source of fugitive emissions must be resurveyed to complete repair according to the requirements of paragraphs (h)(4)(i) through (v) of this section, to ensure that there are no fugitive emissions.

(i) The operator may resurvey the fugitive emissions components to verify repair using either Method 21 of appendix A-7 to this part or OGI, except as specified in paragraph (h)(4)(v) of this section.

(ii) For each repair that cannot be made during the monitoring survey when the fugitive emissions are initially found, a digital photograph must be taken of that component, or the component must be tagged during the monitoring survey when the fugitive emissions were initially found for identification purposes and subsequent repair. The digital photograph must include the date that the photograph was taken and must clearly identify the

component by location within the site (e.g., the latitude and longitude of the component or by other descriptive landmarks visible in the picture).

(iii) Operators that use Method 21 of appendix A-7 to this part to resurvey the repaired fugitive emissions components are subject to the resurvey provisions specified in paragraphs (h)(4)(iii)(A) and (B) of this section.

(A) A fugitive emissions component is repaired when the Method 21 instrument indicates a concentration of less than 500 ppmv above background or when no soap bubbles are observed when the alternative screening procedures specified in section 8.3.3 of Method 21 of appendix A-7 to this part are used.

(B) Operators must use the Method 21 monitoring requirements specified in paragraph (c)(8)(ii) of this section or the alternative screening procedures specified in section 8.3.3 of Method 21 of appendix A-7 to this part.

(iv) Operators that use OGI to resurvey the repaired fugitive emissions components are subject to the resurvey provisions specified in paragraphs (h)(4)(iv)(A) and (B) of this section.

(A) A fugitive emissions component is repaired when the OGI instrument shows no indication of visible emissions.

(B) Operators must use the OGI monitoring requirements specified in paragraph (c)(7) of this section.

(v) For fugitive emissions identified using AVO detection methods, the operator may resurvey using those same methods, Method 21 of appendix A-7 to this part, or OGI. For operators that use AVO detection methods, a fugitive emissions component is repaired when there are no indications of fugitive emissions using these methods.

(i) *Initial compliance.* You must demonstrate initial compliance with the standards that apply to fugitive emissions components affected facilities as required by § 60.5410b(k).

(j) *Continuous compliance.* You must demonstrate continuous compliance with the standards that apply to fugitive emissions components affected facilities as required by § 60.5415b(l).

(k) *Reporting and recordkeeping.* You must comply with the reporting requirements as specified in § 60.5420b(b)(1) and (9), and the recordkeeping requirements as specified in § 60.5420b(c)(16).

(l) *Well closure requirements.* You must complete the requirements specified in paragraphs (l)(1) through (4) of this section.

(1) You must submit a well closure plan to the Administrator within 30 days of the cessation of production from

all wells located at the well site as specified in § 60.5420b(a)(4)(i). The well closure plan must include, at a minimum, the information specified in paragraphs (l)(1)(i) through (iii) of this section.

(i) Description of the steps necessary to close all wells at the well site, including permanent plugging of all wells;

(ii) Description of the financial requirements and disclosure of financial assurance to complete closure; and

(iii) Description of the schedule for completing all activities in the well closure plan.

(2) You must submit a notification as specified in § 60.5420b(a)(4)(ii) of intent to close the well site to the Administrator 60 days before you begin well closure activities.

(3) You must conduct a survey of the well site using OGI, including each closed well, after completing all well closure activities outlined in the well closure plan specified in paragraph (l)(1) of this section. If any emissions are imaged by the OGI instrument, then you must take steps to eliminate those emissions and you must resurvey the source of emissions. You must repeat steps to eliminate emissions and resurvey the source of emissions until no emissions are imaged by the OGI instrument. You must update the well closure plan specified in paragraph (l)(1) of this section to include the video of the OGI survey demonstrating closure of all wells at the site.

(4) You must maintain the records specified in § 60.5420b(c)(14) and submit the reports specified in § 60.5420b(b)(9).

§ 60.5398b What alternative GHG and VOC standards apply to fugitive emissions components affected facilities and what inspection and monitoring requirements apply to covers and closed vent systems when using an alternative technology?

This section provides alternative GHG and VOC standards for fugitive emissions components affected facilities in § 60.5397b and alternative continuous inspection and monitoring requirements for covers and closed vent systems in § 60.5416b(a)(1)(ii) and (iii), (2)(ii) through (iv), and (3)(iii) and (iv). If you choose to use an alternative standard under this section, you must submit the notification under paragraph (a) of this section. If you choose to demonstrate compliance with the alternative GHG and VOC standards through periodic screening, you are subject to the requirements in paragraph (b) of this section. If you choose to demonstrate compliance through a continuous monitoring system, you are

subject to the requirements in paragraph (c) of this section. The technology used for periodic screenings under paragraph (b) of this section or continuous monitoring under paragraph (c) of this section must be approved in accordance with paragraph (d) of this section.

(a) *Notification.* If you choose to demonstrate compliance with the alternative GHG and VOC standards in either paragraph (b) or (c) of this section, you must notify the Administrator of adoption of the alternative standards in the first annual report following implementation of the alternative standards, as specified in § 60.5424b(a). Once you have implemented the alternative standards, you must continue to comply with the alternative standards.

(b) *Periodic Screening.* You may choose to demonstrate compliance for your fugitive emissions components affected facility and compliance with continuous inspection and monitoring requirements for your covers and closed vent systems through periodic screenings using any methane measurement technology approved in accordance with paragraph (d) of this section. If you choose to demonstrate compliance using periodic screenings, you must comply with the requirements in paragraphs (b)(1) through (5) of this section and comply with the recordkeeping and reporting requirements in § 60.5424b.

(1) You must use one or more alternative test method(s) approved per paragraph (d) of this section to conduct periodic screenings.

(i) The required frequencies for conducting periodic screenings are listed in tables 1 and 2 to this subpart. You must choose the appropriate frequency for conducting periodic screenings based on the minimum aggregate detection threshold of the method used to conduct the periodic screenings. You must also use tables 1 and 2 to this subpart to determine whether you must conduct an annual fugitive emissions survey using OGI, except as provided in paragraph (b)(1)(ii) of this section.

(ii) For well sites, centralized production facilities, and compressor stations subject to quarterly OGI monitoring surveys in § 60.5397b(g)(1)(iv) and/or (v), prior to March 9, 2026, if you use an alternative test method approved per paragraph (d) of this section with a minimum aggregated detection threshold less than or equal to 3 kg/hr, in lieu of conducting periodic screening events at the frequency specified in paragraph (b)(1)(i) of this section, you may conduct periodic screening events quarterly.

After March 9, 2026, you must conduct periodic screening events at the frequency specified in paragraph (b)(1)(i) of this section.

(iii) Use of table 1 or 2 to this subpart is based on the required frequency for conducting monitoring surveys in § 60.5397b(g)(1)(i) through (v).

(iv) You may replace one or more individual periodic screening events required by table 1 or 2 to this subpart with an OGI survey. The OGI survey must be conducted according to the requirements outlined in § 60.5397b.

(v) If you use multiple methods to conduct periodic screenings, you must conduct all periodic screenings, regardless of the method used for the individual periodic screening event, at the frequency required for the alternative test method with the highest aggregate detection threshold (e.g., if you use methods with aggregate detection thresholds of 15 kg/hr, your periodic screenings must be conducted monthly). You must also conduct an annual OGI survey if an annual OGI survey is required for the alternative test method with the highest aggregate detection threshold.

(2) You must develop a monitoring plan that covers the collection of fugitive emissions components, covers, and closed vent systems at each site where you will use periodic screenings to demonstrate compliance. You may develop a site-specific monitoring plan, or you may include multiple sites that you own or operate in one plan. At a minimum, the monitoring plan must contain the information specified in paragraphs (b)(2)(i) through (ix) of this section.

(i) Identification of each site that will be monitored through periodic screening, including latitude and longitude coordinates of the site in decimal degrees to an accuracy and precision of at least four decimals of a degree using the North American Datum of 1983.

(ii) Identification of the alternative test method(s) approved per paragraph (d) of this section that will be used for periodic screenings and the spatial resolution (i.e., component-level, area-level, or facility-level) of the technology used for each method.

(iii) Identification of and contact information for the entities that will be performing the periodic screenings.

(iv) Required frequency for conducting periodic screenings, based on the criteria outlined in paragraph (b)(1) of this section.

(v) If you are required to conduct an annual OGI survey by paragraph (b)(1)(i) or (iii) of this section or you choose to replace any individual screening event

with an OGI survey, your monitoring plan must also include the information required by § 60.5397b(b).

(vi) Procedures for conducting monitoring surveys required by paragraphs (b)(5)(ii)(A), (b)(5)(iii)(A), and (b)(5)(iv)(A) of this section. At a minimum, your monitoring plan must include the information required by § 60.5397b(c)(2), (3), (7), and (8), and (d), as applicable. The provisions of § 60.5397b(d)(3) do not apply for purposes of conducting monitoring surveys required by paragraphs (b)(5)(ii) through (iv) of this section.

(vii) Procedures and timeframes for identifying and repairing fugitive emissions components, covers, and closed vent systems from which emissions are detected.

(viii) Procedures and timeframes for verifying repairs for fugitive emissions components, covers, and closed vent systems.

(ix) Records that will be kept and the length of time records will be kept.

(3) You must conduct the initial screening of your site according to the timeframes specified in (b)(3)(i) through (v) of this section.

(i) Within 90 days of the startup of production for each fugitive emissions components affected facility and storage vessel affected facility located at a new well site or centralized production facility.

(ii) Within 90 days of the startup of a new compressor station for each fugitive emissions components affected facility and storage vessel affected facility located at a new compressor station.

(iii) Within 90 days of the startup of production after modification for each modified fugitive emissions components affected facility and storage vessel affected facility at a well site or centralized production facility.

(iv) Within 90 days of modification for each modified fugitive emissions components affected facility and storage vessel affected facility at a compressor station.

(v) No later than the final date by which the next monitoring survey required by § 60.5397b(g)(1)(i) through (v) would have been required to be conducted if you were previously complying with the requirements in § 60.5397b and § 60.5416b(a)(1)(ii) and (iii), (2)(ii) through (iv), and (3)(iii) and (iv).

(4) If you are required to conduct an annual OGI survey by paragraph (b)(1)(i) or (iii) of this section, you must conduct OGI surveys according to the schedule in paragraphs (b)(4)(i) through (iv) of this section.

(i) You must conduct the initial OGI survey no later than 12 calendar months

after conducting the initial screening event in paragraph (b)(3) of this section.

(ii) Each subsequent OGI survey must be conducted no later than 12 calendar months after the previous OGI survey was conducted. Each identified source of fugitive emissions during the OGI survey shall be repaired in accordance with § 60.5397b(h).

(iii) If you replace a periodic screening event with an OGI survey or you are required to conduct a monitoring survey in accordance with paragraph (b)(5)(ii)(A) of this section prior to the date that your next OGI survey under paragraph (b)(4)(ii) of this section is due, the OGI survey conducted in lieu of the periodic screening event or the monitoring survey under paragraph (b)(5)(ii)(A) of this section can be used to fulfill the requirements of paragraph (b)(4)(ii) of this section. The next OGI survey is required to be conducted no later than 12 calendar months after the date of the survey conducted under paragraph (b)(1)(iv) or (b)(5)(ii)(A) of this section.

(iv) You cannot use a monitoring survey conducted under paragraph (b)(5)(iii)(A) or (b)(5)(iv)(A) of this section to fulfill the requirements of paragraph (b)(4)(ii) of this section unless the monitoring survey included all fugitive emission components at the site.

(5) You must investigate confirmed detections of emissions from periodic screening events and repair each identified source of emissions in accordance with paragraphs (b)(5)(i) through (vii) of this section.

(i) You must receive the results of the periodic screening no later than 5 calendar days after the screening event occurs.

(ii) If you use an alternative test method with a facility-level spatial resolution to conduct a periodic screening event and the results of the periodic screening event indicate a confirmed detection of emissions from an affected facility, you must take the actions listed in paragraphs (b)(5)(ii)(A) through (C) of this section.

(A) You must conduct a monitoring survey of the entire fugitive emissions components affected facility following the procedures in your monitoring plan. During the survey, you must observe each fugitive emissions component for fugitive emissions.

(B) You must inspect all covers and closed vent system(s) with OGI or Method 21 to appendix A-7 to this part in accordance with the requirements in § 60.5416b(b)(1) through (4), as applicable.

(C) You must conduct a visual inspection of all covers and closed vent

systems to identify if there are any defects, as defined in § 60.5416b(a)(1)(ii), (a)(2)(iii), or (a)(3)(i), as applicable.

(iii) If you use an alternative test method with an area-level spatial resolution to conduct a periodic screening event and the results of the periodic screening event indicate a confirmed detection of emissions from an affected facility, you must take the actions listed in paragraphs (b)(5)(iii)(A) and (B) of this section, as applicable.

(A) You must conduct a monitoring survey of all your fugitive emissions components located within a 4-meter radius of the location of the periodic screening's confirmed detection. You must follow the procedures in your monitoring plan when conducting the survey.

(B) If the confirmed detection occurred in the portion of a site that contains a storage vessel or a closed vent system, you must inspect all covers and all closed vent systems that are connected to all storage vessels and closed vent systems that are within a 2-meter radius of the location of the periodic screening's confirmed detection (*i.e.*, you must inspect the whole system that is connected to the portion of the system in the radius of the detected event, not just the portion of the system that falls within the radius of the detected event).

(1) You must inspect the cover(s) and closed vent system(s) with OGI or Method 21 to appendix A-7 to this part in accordance with the requirements in § 60.5416b(b)(1) through (4), as applicable.

(2) You must conduct a visual inspection of the closed vent system(s) and cover(s) to identify if there are any defects, as defined in § 60.5416b(a)(1)(ii), (a)(2)(iii), or (a)(3)(i), as applicable.

(iv) If you use an alternative test method with a component-level spatial resolution to conduct a periodic screening event and the results of the periodic screening event indicate a confirmed detection of emissions from an affected facility, you must take the actions listed in paragraphs (b)(5)(iv)(A) and (B) of this section, as applicable.

(A) You must conduct a monitoring survey of the all the fugitive emissions components located within a 1-meter radius of the location of the periodic screening's confirmed detection. You must follow the procedures in your monitoring plan when conducting the survey.

(B) If the confirmed detection occurred in the portion of a site that contains a storage vessel or a closed vent system, you must inspect all covers

and all closed vent systems that are connected to all storage vessels and closed vent systems that are within a 0.5-meter radius of the location of the periodic screening's confirmed detection (*i.e.*, you must inspect the whole system that is connected to the portion of the system in the radius of the detected event, not just the portion of the system that falls within the radius of the detected event).

(1) You must inspect the cover(s) and closed vent system(s) with OGI or Method 21 to appendix A-7 to this part in accordance with the requirements in § 60.5416b(b)(1) through (4), as applicable.

(2) You must conduct a visual inspection of the closed vent system(s) and cover(s) to identify if there are any defects, as defined in § 60.5416b(a)(1)(ii), (a)(2)(iii), or (a)(3)(i), as applicable.

(v) You must repair all sources of fugitive emissions in accordance with § 60.5397b(h) and all emissions or defects of covers and closed vent systems in accordance with § 60.5416b(b)(5), except as specified in this paragraph (b)(5)(v). Except as allowed by § 60.5397b(h)(3) and § 60.5416b(b)(6), all repairs must be completed, including the resurvey verifying the repair, within 30 days of receiving the results of the periodic screening in paragraph (b)(5)(i) of this section.

(vi) If the results of the periodic screening event in paragraph (b)(5)(i) of this section indicate a confirmed detection at an affected facility, and the ground-based monitoring survey and inspections required by paragraphs (b)(5)(ii) through (iv) of this section demonstrate the confirmed detection was caused by a failure of a control device used to demonstrate continuous compliance under this subpart, you must initiate an investigative analysis to determine the underlying primary and other contributing cause(s) of such failure within 24 hours of receiving the results of the monitoring survey and/or inspection. As part of the investigation, you must determine if the control device is operating in compliance with the applicable requirements of § 60.5415b and § 60.5417b, and if not, what actions are necessary to bring the control device into compliance with those requirements as soon as possible and prevent future failures of the control device from the same underlying cause(s).

(vii) If the results of the inspections required in paragraphs (b)(5)(ii) through (iv) of this section indicate that there is an emission or defect in your cover or closed vent system, you must perform

an investigative analysis to determine the underlying primary and other contributing cause(s) of emissions from your cover or closed vent system within 5 days of completing the inspection required by paragraphs (b)(5)(ii) through (iv) of this section. The investigative analysis must include a determination as to whether the system was operated outside of the engineering design analysis and whether updates are necessary for the cover or closed vent system to prevent future emissions from the cover and closed vent system.

(6) You must maintain records as specified in § 60.5420b(c)(4) through (7), (14), and (15), and § 60.5424b(c).

(7) You must submit reports as specified in § 60.5424b.

(c) *Continuous monitoring.* You may choose to demonstrate compliance for your fugitive emissions components affected facility and compliance with continuous inspection and monitoring requirements for your covers and closed vent systems through continuous monitoring using a technology approved in accordance with paragraph (d) of this section. If you choose to demonstrate compliance using continuous monitoring, you must comply and develop a monitoring plan consistent with the requirements in paragraphs (c)(1) through (9) of this section and comply with the recordkeeping and reporting requirements in § 60.5424b.

(1) For the purpose of this section, continuous monitoring means the ability of a methane monitoring system to determine and record a valid methane mass emissions rate or equivalent of affected facilities at least once for every 12-hour block.

(i) The detection threshold of the system must be such that it can detect at least 0.40 kg/hr (0.88 lb/hr) of methane.

(ii) The health of the devices used within the continuous monitoring system must be confirmed for power and function at least twice every six-hour block.

(iii) The continuous monitoring system must transmit all applicable valid data at least once every 24-hours. The continuous monitoring system must transmit all valid data collected, including health checks required in paragraph (c)(1)(ii) of this section.

(iv) The continuous monitoring system must continuously collect data as specified in paragraph (c)(1) of this section, except as specified in paragraphs (c)(1)(iv)(A) through (D) of this section:

(A) The rolling 12-month average operational downtime of the continuous monitoring system must be less than or equal to 10 percent.

(B) Operational downtime of the continuous monitoring system is defined as a period of time for which any monitor fails to collect or transmit data as specified in paragraph (c)(1) of this section or any monitor is out-of-control as specified in paragraph (c)(1)(iv)(C) of this section.

(C) A monitor is out-of-control if it fails ongoing quality assurance checks, as specified in the alternative test method approved under paragraph (d) of this section, or if the monitor output is outside of range. The beginning of the out-of-control period is defined as the time of the failure of the quality assurance check. The end of the out-of-control period is defined as the time when either the monitor passes a subsequent quality assurance check, or a new monitor is installed. The out-of-control period for a monitor outside of range starts at the time when the monitor first reads outside of range and ends when the monitor reads within range again.

(D) The downtime for the continuous monitoring system must be calculated each calendar month. Once 12 months of data are available, at the end of each calendar month, you must calculate the 12-month average by averaging that month with the previous 11 calendar months. You must determine the rolling 12-month average by recalculating the 12-month average at the end of each month.

(2) You must develop a monitoring plan that covers the collection of fugitive emissions components, covers, and closed vent systems for each site where continuous monitoring will be used to demonstrate compliance. At a minimum, the monitoring plan must contain the information specified in paragraphs (c)(2)(i) through (xii) of this section.

(i) Identification of each site to be monitored through continuous monitoring, including latitude and longitude coordinates of the site in decimal degrees to an accuracy and precision of at least four decimals of a degree using the North American Datum of 1983.

(ii) Identification of the alternative test method(s) approved under paragraph (d) of this section used for the continuous monitoring, including the detection principle; the manufacturer, make, and model; instrument manual, if applicable; and the manufacturer's recommended maintenance schedule.

(iii) If the continuous monitoring system is administered through a third-party provider, contact information where the provider can be reached 24 hours a day.

(iv) Number and location of monitors. If the continuous monitoring system uses open path technology, you must identify the location of any reflectors used. These locations should be identified by latitude and longitude coordinates in decimal degrees to an accuracy and precision of at least five decimals of a degree using the North American Datum of 1983.

(v) Discussion of system calibration requirements, including but not limited to, the calibration procedures and calibration schedule for the detection systems and meteorology systems.

(vi) Identification of critical components and infrastructure (e.g., power, data systems) and procedures for their repairs.

(vii) Procedures for out-of-control periods.

(viii) Procedures for establishing baseline emissions, including the identification of any sources with methane emissions not subject to this subpart. The procedures for establishing the baseline emissions must account for variability in the operation of the site. Operation of the site during the development of the baseline emissions must represent the site's expected annual production or throughput.

(ix) Procedures for determining when a fugitive emissions event is detected by the continuous monitoring technology.

(x) Procedures and timeframes for identifying and repairing fugitive emissions components, covers, and closed vent systems from which emissions are detected.

(xi) Procedures and timeframes for verifying repairs for fugitive emissions components, covers, and closed vent systems.

(xii) Records that will be kept and the length of time records will be kept.

(3) You must install and begin conducting monitoring with your continuous monitoring system according to the timeframes specified in paragraphs (c)(3)(i) through (v) of this section.

(i) Within 120 days of the startup of production for each fugitive emissions components affected facility and storage vessel affected facility located at a new well site or centralized production facility.

(ii) Within 120 days of the startup of a new compressor station for each fugitive emissions components affected facility and storage vessel affected facility located at a new compressor station.

(iii) Within 120 days of the startup of production after modification for each modified fugitive emissions components affected facility and storage vessel

affected facility at a well site or centralized production facility.

(iv) Within 120 days of modification for each modified fugitive emissions components affected facility and storage vessel affected facility at a compressor station.

(v) No later than the final date by which the next monitoring survey required by § 60.5397b(g)(1)(i) through (v) would have been required to be conducted if you were previously complying with the requirements in § 60.5397b and § 60.5416b(a)(1)(ii) and (iii), (2)(ii) through (iv), and (3)(iii) and (iv).

(4) You are subject to the following action-levels as specified in paragraphs (c)(4)(i) and (ii) of this section for any affected facilities located at a well site, centralized production facility, or compressor station.

(i) For affected facilities located at a wellhead only well site, the action levels are as follows:

(A) The 90-day rolling average action-level is 1.2 kg/hr (2.6 lb/hr) of methane over the site-specific baseline emissions.

(B) The 7-day rolling average action level is 15 kg/hr (34 lb/hr) of methane over site-specific baseline emissions.

(ii) For affected facilities located at well sites with major production and processing equipment (including small well sites), centralized production facilities, and compressor stations, the action levels are as follows:

(A) The 90-day rolling average action-level is 1.6 kg/hr (3.6 lb/hr) of methane over the site-specific baseline emissions.

(B) The 7-day rolling average action level is 21 kg/hr (46 lb/hr) of methane over the site-specific baseline emissions.

(5) You must establish site-specific baseline emissions upon initial installation and activation of a continuous monitoring system. You must establish the baseline emissions under the conditions outlined in paragraphs (c)(5)(i) through (iii) of this section. You must determine the baseline emission rates according to paragraphs (c)(5)(iv) and (v) of this section. The baseline must be established initially and any time there is a major change to the processing equipment at a well site (including small well sites), centralized production facility, or compressor station.

(i) Inspect all fugitive emissions components according to the requirements in § 60.5397b and covers and closed vent systems according to the requirements in § 60.5416b. This includes all fugitive emissions components, covers, and closed vent systems, regardless of whether they are regulated by this subpart. Repairs of any fugitive emissions, leaks, or defects

found during the inspection must be completed prior to beginning the period in paragraph (c)(5)(iii) of this section.

(ii) Verify control devices (e.g., flares) on all affected sources are operating in compliance with the applicable requirements of § 60.5415b and § 60.5417b. You must ensure that all control devices are operating in compliance with the applicable regulations prior to beginning the period in paragraph (b)(5)(iii) of this section. Verify that all other methane emission sources (e.g., reciprocating engines) located at the site are operating consistent with any applicable regulations. You must ensure that these sources are operating in compliance with the applicable regulations prior to beginning the period in paragraph (b)(5)(iii) of this section.

(iii) Using the alternative test method approved under paragraph (d) of this section, record the site-level emission rate from your continuous monitoring system for 30 operating days. You must minimize any activities that are not normal, day-to-day activities during this 30 operating day period. Document any maintenance activities and the period (including the start date and time and end date and time) such activities occurred during the 30 operating day period.

(iv) Determine the site-specific baseline by calculating the mean emission rate (kg/hr of methane) for the 30 operating day period, less any time periods when maintenance activities were conducted.

(v) The site-specific baseline emission rate must be no more than 10 times the applicable 90-day action-level defined in paragraphs (c)(4)(i) and (ii) of this section.

(6) Calculate the emission rate from your site according to paragraphs (c)(6)(i) through (iii) of this section. Compare the emission rate calculated in this paragraph (c)(6) to the appropriate action levels in paragraph (c)(4) of this section to determine whether you have exceeded an action level.

(i) Each calendar day, calculate the daily average mass emission rate in kg/hr of methane from your continuous monitoring system.

(ii) Once the system has been operating for 7 calendar days, at the end of each calendar day calculate the 7-day average mass emission rate by averaging the mass emission rate from that day with the mass emission rate from the previous 6 calendar days. Subtract the site-specific baseline mass emission rate from the 7-day average mass emission rate when comparing the mass emission rate to the applicable action level. Determine the 7-day rolling average by

recalculating the 7-day average each calendar day, less the site-specific baseline.

(iii) Once the system has been operating for 90 calendar days, at the end of each calendar day calculate the 90-day average mass emission rate by averaging the mass emission rate from that day with the mass emission rate from the previous 89 calendar days. Subtract the site-specific baseline emission rate from the 90-day average mass emission rate when comparing the mass emission rate to the applicable action level. Determine the 90-day rolling average by recalculating the 90-day average each calendar day, less the site-specific baseline.

(7) Within 5 days of determining that either of your action levels in paragraph (c)(4) of this section has been exceeded, you must initiate an investigative analysis to determine the underlying primary and contributing cause(s) of such exceedance and actions to be taken to reduce the mass emission rate below the applicable action level.

(i) You must complete the investigative analysis and take initial steps to bring the mass emission rate below the action level no later than 5 days after determining there is an exceedance of the action level in paragraph (c)(4)(i)(B) or (c)(4)(ii)(B) of this section.

(ii) You must complete the investigative analysis and take initial steps to bring the mass emission rate below the action level no later than 30 days after determining there is an exceedance of the action level in paragraph (c)(4)(i)(A) or (c)(4)(ii)(A) of this section.

(8) You must develop a mass emission rate reduction plan if you meet any of the criteria in paragraphs (c)(8)(i) through (iii) of this section. The plan must describe the action(s) completed to date to reduce the mass emission rate below the action level, additional measures that you propose to employ to reduce methane emissions below the action level, and a schedule for completion of these measures. You must submit the plan to the Administrator within 60 days of initially determining there is an exceedance of an action level in paragraph (c)(4) of this section.

(i) If, upon completion of the initial actions required under paragraph (c)(7) of this section, the average mass emission rate for the following 30-day period is not below the applicable action level in paragraph (c)(4)(i)(A) or (c)(4)(ii)(A) of this section. The beginning of the 30-day period starts on the calendar day following completion of the initial actions in paragraph (c)(7) of this section.

(ii) If, upon completion of the initial actions required under paragraph (c)(6) of this section, the average mass emission rate for the following 24-hour period is not below the applicable action level in paragraph (c)(4)(i)(B) or (c)(4)(ii)(B) of this section. The average mass emission rate will be the mass emission rate calculated according to paragraph (c)(6)(i) of this section for the calendar day following completion of the initial corrective actions in paragraph (c)(7) of this section.

(iii) All actions needed to reduce the average mass emission rate below the action level require more than 30 days to implement.

(9) You must maintain the records as specified in § 60.5420b(c)(4) through (c)(7), (c)(14) and (c)(15), and § 60.5424b(e). You must submit the reports as specified in § 60.5420b(b)(1), and (b)(4) through (10) and § 60.5424b.

(d) *Alternative Test Method for Methane Detection Technology.* Any alternative test method for methane detection technology used to meet the requirements specified in paragraphs (b) or (c) of this section or § 60.5371b must be approved by the Administrator as specified in this paragraph (d). Approval of an alternative test method for methane detection technology will include consideration of the combination of the measurement technology and the standard protocol for its operation. Any entity meeting the requirements in paragraph (d)(2) of this section may submit a request for an alternative test method for methane detection technology. At a minimum, the request must follow the requirements outlined in paragraph (d)(3) of this section. Approved alternative test methods for methane detection technology that are broadly applicable will be posted on the EPA's Emission Measurement Center web page (<https://www.epa.gov/emc/oil-and-gas-alternative-test-methods>). Any owner or operator that meets the specific applicability for the alternative test method, as outlined in the alternative test method for methane detection technology, may use the alternative test method to comply with the requirements of paragraph (b) or (c) of this section, as applicable, in lieu of the requirements for fugitive emissions components affected facilities in § 60.5397b and covers and closed vent systems in § 60.5416b(a)(1)(ii) and (iii), (a)(2)(ii) through (iv), and (a)(3)(iii) and (iv). Certified third-party notifiers may use the alternative test method to identify super-emitter events in § 60.5371b(b)(1)(ii).

(1) A request for an alternative test method for methane detection

technology, along with the required supporting information, must be submitted to the EPA through the alternative methane detection technology portal at <https://www.epa.gov/emc/oil-and-gas-alternative-test-methods>. The EPA may make all the information submitted through the portal available to the public without further notice to you. Do not use the portal to submit information you claim as confidential business information (CBI). If you wish to assert a CBI claim for some of the information in your submittal, submit the portion of the information claimed as CBI to the OAQPS CBI office. Clearly mark the information that you claim to be CBI. Information not marked as CBI may be authorized for public release without prior notice. Information marked as CBI will not be disclosed except in accordance with procedures set forth in 40 CFR part 2. All CBI claims must be asserted at the time of submission. Anything submitted using the portal cannot later be claimed CBI. The preferred method to receive CBI is for it to be transmitted electronically using email attachments, File Transfer Protocol, or other online file sharing services. Electronic submissions must be transmitted directly to the OAQPS CBI Office at the email address oaqpscbi@epa.gov and should include clear CBI markings and be flagged to the attention of the Leader, Measurement Technology Group. If assistance is needed with submitting large electronic files that exceed the file size limit for email attachments, and if you do not have your own file sharing service, please email oaqpscbi@epa.gov to request a file transfer link. If you cannot transmit the file electronically, you may send CBI information through the postal service to the following address: U.S. EPA, Attn: OAQPS Document Control Officer and Measurement Technology Group Leader, Mail Drop: C404-02, 109 T.W. Alexander Drive, P.O. Box 12055, RTP, North Carolina 27711. The mailed CBI material should be double wrapped and clearly marked. Any CBI markings should not show through the outer envelope.

(i) The Administrator will complete an initial review for completeness within 90 days of receipt and notify the submitter of the results of the review.

(ii) If the entity submitting the request does not meet the requirements in paragraph (d)(2) of this section or the request does not contain the information in paragraph (d)(3) of this section, the submitter will be notified. The submitter may choose to revise the information and submit a new request for an alternative test method.

(iii) Within 270 days of receipt of an alternative test method request that was determined to be complete, the Administrator will determine whether the requested alternative test method is adequate for indicating compliance with the requirements for monitoring fugitive emissions components affected facilities in § 60.5397b and continuous inspection and monitoring of covers and closed vent systems in § 60.5416b and/or for identifying super-emitter events in § 60.5371b. The Administrator will issue either an approval or disapproval in writing to the submitter. Approvals may be considered site-specific or more broadly applicable. Broadly applicable alternative test methods and approval letters will be posted at <https://www.epa.gov/emc/oil-and-gas-approved-alternative-test-methods-approvals>. If the Administrator fails to provide the submitter a decision on approval or disapproval within 270 days, the alternative test method will be given conditional approval status and posted on this same web page. If the Administrator finds any deficiencies in the request and disapproves the request in writing, the owner or operator may choose to revise the information and submit a new request for an alternative test method.

(iv) If the Administrator finds reasonable grounds to dispute the results obtained by any alternative test method for the purposes of demonstrating compliance with a relevant standard, the Administrator may require you to demonstrate compliance according to § 60.5397b for fugitive emissions components affected facilities and § 60.5416b for covers and closed vent systems.

(2) Any entity may submit an alternative test method for consideration, so long as you meet the requirements in paragraphs (d)(2)(i) through (iv) of this section.

(i) An entity is limited to any individual or organization located in or that has representation in the United States.

(ii) If an entity is not considered an owner or operator of an affected facility regulated under this subpart or subpart OOOOa of this part or is not the owner or operator of a designated facility regulated under subpart OOOOc of this part, the provisions of paragraphs (d)(2)(ii)(A) and (B) of this section apply.

(A) The entity must directly represent the provider of the measurement system using advanced methane detection technology.

(B) The measurement system must have been applied to methane measurements or monitoring in the oil

and gas sector either domestically or internationally.

(iii) The underlying technology or technologies must be readily available for use, meaning that the measurement system using these technologies has either been:

(A) Sold, leased, or licensed, or offered for sale, lease, or license to the general public or;

(B) Developed by an owner or operator for internal use and/or use by external partners.

(iv) The entity must be able to provide and submit to the Administrator the information required in paragraph (d)(3) of this section.

(3) The request must contain the information specified in paragraphs (d)(3)(i) through (vii) of this section.

(i) The submitter's name, mailing address, phone number and email address.

(ii) The desired applicability of the technology (*i.e.*, site-specific, basin-specific, or broadly applicable across the sector, super-emitter detection).

(iii) Description of the measurement technology, including the physical components, the scientific theory, and the known limitations. At a minimum, this description must contain the information in paragraphs (d)(3)(iii)(A) through (D) of this section.

(A) Description of scientific theory and appropriate references outlining the underlying technology (*e.g.*, reference material, literature review).

(B) Description of the physical instrumentation.

(C) Type of measurement and application (*e.g.*, remote or in-situ measurements, mobile, airborne).

(D) Known limitation of the technology, including application limitations and weather limitations.

(iv) Description of how the measurement technology is converted to a methane mass emission rate (*i.e.*, kg/hr of methane) or equivalent. At a minimum this description must contain the information in paragraphs (d)(3)(iv)(A) through (F) of this section.

(A) Detailed workflow and description covering all steps and processes from measurement technology signal output to final, validated mass emission rate or equivalent. These workflows must cover the material in paragraph (d)(3)(v) of this section and put all technical components into context. The workflow must also cover the technology from data collection to generation of the final product and identify any raw data processing procedures; identification of whether processing steps are manual or automated, and when and what quality assurance checks are made to the data,

including raw data, processed data, and output data.

(B) Description of how any meteorological data used are collected or sourced, including a description how the data are used.

(C) Description of any model(s) (*e.g.*, AERMOD) used, including how inputs are determined or derived.

(D) All calculations used, including the defined variables for any of these calculations and a description of their purposes.

(E) Descriptions of a-priori methods and datasets used, including source and version numbers when applicable.

(F) Description of algorithms/machine learning procedures used in the data processing, if applicable.

(v) Description of how all data collected and generated by the measurement system are handled and stored. At a minimum this description must contain the information in paragraphs (d)(3)(v)(A) through (C) of this section.

(A) How the data, including metadata, are collected, maintained, and stored.

(B) A description of how raw data streams are processed and manipulated, including how the resultant data processing is documented and how version controlled is maintained.

(C) A description of what data streams are provided to the end-user of the data and how the data are delivered to the end-user.

(vi) Supporting information verifying that the technology meets the aggregate detection threshold(s) defined in paragraphs (b) and/or (c) of this section or in § 60.5371b, including supporting data to demonstrate the aggregate detection threshold of the measurement technology as applied in the field and if applicable, how probability of detection is determined. For the purpose of this subpart the average aggregate detection threshold is the average of all site-level detection thresholds from a single deployment (*e.g.*, a singular flight that surveys multiple well sites, centralized production facility, and/or compressor stations) of a technology, unless this technology is to be applied to § 60.5371b. When the technology is applied to § 60.5371b, then the aggregate detection threshold is the average of all site-level detection thresholds from a single deployment in the same basin and field. At a minimum, you provide the information identified in paragraphs (d)(3)(vi)(A) through (D) of this section.

(A) Published reports (*e.g.*, scientific papers) produced by either the submitting entity or an outside entity evaluating the submitted measurement technology that has been independently

evaluated. The published reports must identify either a site-level or aggregate detection threshold and be accompanied with sufficient supporting data to evaluate whether the performance metrics of the alternative testing procedures in paragraph (d)(3)(vi)(C) of this section are adequate and the data was collected consistent with those alternative testing procedures. The supporting data may be included in the published report or may be submitted separately.

(B) Standard operating procedures including safety considerations, measurement limitations, personnel qualification/responsibilities, equipment and supplies, data and record management, and quality assurance/quality control (*i.e.*, initial and ongoing calibration procedures, data quality indicators, and data quality objectives).

(C) Detailed description of the alternative testing procedure(s), preferably in the format described in Guideline Document 45 on the Emission Measurement Center's website (available at <https://www.epa.gov/sites/default/files/2020-08/documents/gd-045.pdf>). The detailed description must address all key elements of the requested method(s) and must include objectives to ensure the detection threshold(s) required in paragraph (d)(3)(vi) of this section are maintained, including procedures for verifying the detection threshold and/or or probability of detection is maintained under field conditions.

(D) Any documents provided to end-users of the data generated by the measurement system, including but not limited to client products, manuals, and frequently asked questions documents.

(vii) If the technology will be used to monitor the collection of fugitive emissions components, covers, and closed vent systems at a well site, centralized production facility, or compressor station, you must submit supporting information verifying the spatial resolution of technology, as defined in paragraphs (d)(3)(vii)(A) through (C) of this section. This supporting information must be in the form of a published reports (*e.g.*, scientific papers) produced by either the submitting entity or an outside entity evaluating the submitted measurement technology that has been independently evaluated. The report must include sufficient supporting data to evaluate whether the performance metrics of the alternative testing procedures in paragraph (d)(3)(vi)(C) of this section are adequate and the data was collected consistent with those alternative testing procedures.

(A) Facility-level spatial resolution means a technology with the ability to identify emissions within the boundary of a well site, centralized production facility, or compressor station.

(B) Area-level spatial resolution means a technology with the ability to identify emissions within a radius of 2 meters of the emission source.

(C) Component-level spatial resolution means a technology with the ability to identify emissions within a radius of 0.5 meter of the emission source.

§ 60.5399b What are the alternative means of emission limitations for GHG and VOC emissions from well completions, liquids unloading operations, centrifugal compressors, reciprocating compressors, fugitive emissions components, and process unit equipment affected facilities; and what are the alternative fugitive emissions standards based on State, local, and Tribal programs?

This section provides procedures for the submittal and approval of alternative means of emission limitation for GHG and VOC based on work practices for well completions, liquids unloading operations, centrifugal compressors, reciprocating compressors, fugitive emissions components and process unit equipment affected facilities. This section also provides procedures for the submittal and approval of alternative fugitive emissions standards based on programs under state, local, or Tribal authorities for the fugitive emissions components affected facility. Paragraphs (a) through (d) of this section outline the procedure for submittal and approval of alternative means of emission limitation for methane and VOC. Paragraphs (e) through (i) of this section outline the procedure for submittal and approval of alternative fugitive emissions standards. The requirements for a monitoring plan specified in § 60.5397b(c) and (d) apply to the alternative fugitive emissions standards in this section.

(a) *Alternative means of emission limitation.* If, in the Administrator's judgment, an alternative means of emission limitation will achieve a reduction in methane and VOC emissions at least equivalent to the reduction in methane and VOC emissions achieved under § 60.5375b, § 60.5376b, § 60.5380b, § 60.5385b, § 60.5397b, § 60.5400b, or § 60.5401b, the Administrator will publish, in the **Federal Register**, a notice permitting the use of that alternative means for the purpose of compliance with § 60.5375b, § 60.5376b, § 60.5380b, § 60.5385b, § 60.5397b, § 60.5400b, or § 60.5401b. The authority to approve an alternative means of emission limitation is retained

by the Administrator and shall not be delegated to States under section 111(c) of the CAA.

(b) *Notice.* Any notice under paragraph (a) of this section must be published only after notice and an opportunity for a public hearing.

(c) *Evaluation guidelines.* Determination of equivalence to the design, equipment, work practice, or operational requirements of this section will be evaluated by the following guidelines:

(1) The applicant must provide information that is sufficient for demonstrating the alternative means of emission limitation achieves emission reductions that are at least equivalent to the emission reductions that would be achieved by complying with the relevant standards. At a minimum, the application must include the following information:

(i) Details of the specific equipment or components that would be included in the alternative.

(ii) A description of the alternative work practice, including, as appropriate, the monitoring method, monitoring instrument or measurement technology, and the data quality indicators for precision and bias.

(iii) The method detection limit of the technology, technique, or process and a description of the procedures used to determine the method detection limit. At a minimum, the applicant must collect, verify, and submit field data encompassing seasonal variations to support the determination of the method detection limit. The field data may be supplemented with modeling analyses, controlled test site data, or other documentation.

(iv) Any initial and ongoing quality assurance/quality control measures necessary for maintaining the technology, technique, or process, and the timeframes for conducting such measures.

(v) Frequency of measurements. For continuous monitoring techniques, the minimum data availability.

(vi) Any restrictions for using the technology, technique, or process.

(vii) Initial and continuous compliance procedures, including recordkeeping and reporting, if the compliance procedures are different than those specified in this subpart.

(2) For each technology, technique, or process for which a determination of equivalency is requested, the application must provide a demonstration that the emission reduction achieved by the alternative means of emission limitation is at least equivalent to the emission reduction that would be achieved by complying

with the relevant standards in this subpart.

(d) *Approval of alternative means of emission limitation.* Any alternative means of emission limitations approved under this section shall constitute a required work practice, equipment, design, or operational standard within the meaning of section 111(h)(1) of the CAA.

(e) *Alternative fugitive emissions standards.* If, in the Administrator's judgment, an alternative fugitive emissions standard will achieve a reduction in methane and VOC emissions at least equivalent to the reductions achieved under § 60.5397b, the Administrator will publish, in the **Federal Register**, a notice permitting use of the alternative fugitive emissions standard for the purpose of compliance with § 60.5397b. The authority to approve alternative fugitive emissions standards is retained by the Administrator and shall not be delegated to States under section 111(c) of the CAA.

(f) *Notice.* Any notice under paragraph (e) of this section will be published only after notice and an opportunity for public hearing.

(g) *Evaluation guidelines.* Determination of alternative fugitive emissions standards to the design, equipment, work practice, or operational requirements of § 60.5397b will be evaluated by the following guidelines:

- (1) The monitoring instrument, including the monitoring procedure;
- (2) The monitoring frequency;
- (3) The fugitive emissions definition;
- (4) The repair requirements; and
- (5) The recordkeeping and reporting requirements.

(h) *Approval of alternative fugitive emissions standard.* Any alternative fugitive emissions standard approved under this section shall:

- (1) Constitute a required design, equipment, work practice, or operational standard within the meaning of section 111(h)(1) of the CAA; and
- (2) Be made available for use by any owner or operator in meeting the relevant standards and requirements established for affected facilities under § 60.5397b.

(i) *Notification.* (1) An owner or operator must notify the Administrator of adoption of the alternative fugitive emissions standards within the first annual report following implementation of the alternative fugitive emissions standard, as specified in § 60.5420b(a)(3).

(2) An owner or operator implementing one of the alternative

fugitive emissions standards must submit the reports specified in § 60.5420b(b)(9)(iii). An owner or operator must also maintain the records specified by the specific alternative fugitive emissions standard for a period of at least 5 years.

§ 60.5400b What GHG and VOC standards apply to process unit equipment affected facilities?

This section applies to process unit equipment affected facilities located at an onshore natural gas processing plant. You must comply with the requirements of paragraphs (a) through (l) of this section to reduce methane and VOC emissions from equipment leaks, except as provided in § 60.5402b. As an alternative to the standards in this section, you may comply with the requirements in § 60.5401b.

(a) *General standards.* You must comply with the requirements in paragraphs (b) through (d) of this section for each pump in light liquid service, pressure relief device in gas/vapor service, valve in gas/vapor or light liquid service, and connector in gas/vapor or light liquid service, as applicable. You must comply with the requirements in paragraph (e) of this section for each open-ended valve or line. You must comply with the requirements in paragraph (f) of this section for each closed vent system and control device used to comply with equipment leak provisions in this section. You must comply with paragraph (g) of this section for each pump, valve, and connector in heavy liquid service and pressure relief device in light liquid or heavy liquid service. You must make repairs as specified in paragraph (h) of this section. You must demonstrate initial compliance with the standards as specified in paragraph (i) of this section. You must demonstrate continuous compliance with the standards as specified in paragraph (j) of this section. You must perform the reporting as specified in paragraph (k) of this section. You must perform the recordkeeping as required in paragraph (l) of this section.

(1) You may apply to the Administrator for permission to use an alternative means of emission limitation that achieves a reduction in emissions of methane and VOC at least equivalent to that achieved by the controls required in this subpart according to the requirements of § 60.5399b.

(2) Each piece of equipment is presumed to have the potential to emit methane or VOC unless an owner or operator demonstrates that the piece of equipment does not have the potential to emit methane or VOC. For a piece of

equipment to be considered not to have the potential to emit methane or VOC, the methane and VOC content of a gaseous stream must be below detection limits using Method 18 of appendix A–6 to this part. Alternatively, if the piece of equipment is in wet gas service, you may choose to determine the methane and VOC content of the stream is below the detection limit of the methods described in ASTM E168–16(R2023), E169–16(R2022), or E260–96 (all incorporated by reference, see § 60.17).

(b) *Monitoring surveys.* You must monitor for leaks using OGI in accordance with appendix K of this part, unless otherwise specified in paragraphs (c) or (d) of this section.

(1) Monitoring surveys must be conducted bimonthly.

(2) Any emissions observed using OGI are defined as a leak.

(c) *Additional requirements for pumps in light liquid service.* In addition to the requirements in paragraph (b), you must conduct weekly visual inspections of all pumps in light liquid service for indications of liquids dripping from the pump seal, except as specified in paragraphs (c)(3) and (4) of this section. If there are indications of liquids dripping from the pump seal, you must follow the procedure specified in either paragraph (c)(1) or (2) of this section.

(1) Monitor the pump within 5 calendar days using the methods specified in § 60.5403b. A leak is detected if any emissions are observed using OGI or if an instrument reading of 2,000 ppmv or greater is provided using Method 21 of appendix A–7 to this part.

(2) Designate the visual indications of liquids dripping as a leak and repair the leak as specified in paragraph (h) of this section.

(3) If any pump is equipped with a closed vent system capable of capturing and transporting any leakage from the seal or seals to a process, fuel gas system, or a control device that complies with the requirements of paragraph (f) of this section, it is exempt from the weekly inspection requirements in paragraph (c) of this section.

(4) Any pump that is located within the boundary of an unmanned plant site is exempt from the weekly visual inspection requirements in paragraph (c) of this section, provided that each pump is visually inspected as often as practicable and at least bimonthly.

(d) *Additional requirements for pressure relief devices in gas/vapor service.* In addition to the requirements in paragraph (b) of this section, you must monitor each pressure relief device as specified in paragraph (d)(1)

of this section, except as specified in paragraphs (d)(2) and (3) of this section.

(1) You must monitor each pressure relief device within 5 calendar days after each pressure release to detect leaks using the methods specified in § 60.5403b. A leak is detected if any emissions are observed using OGI or if an instrument reading of 500 ppmv or greater is provided using Method 21 of appendix A–7 to this part.

(2) Any pressure relief device that is located in a nonfractionating plant that is monitored only by non-plant personnel may be monitored after a pressure release the next time the monitoring personnel are onsite or within 30 calendar days after a pressure release, whichever is sooner, instead of within 5 calendar days as specified in paragraph (d)(1) of this section. No pressure relief device described in this paragraph may be allowed to operate for more than 30 calendar days after a pressure release without monitoring.

(3) Any pressure relief device that is routed to a process or fuel gas system or equipped with a closed vent system capable of capturing and transporting leakage through the pressure relief device to a control device as described in paragraph (f) of this section is exempt from the requirements of paragraph (d)(1) of this section.

(e) *Open-ended valves or lines.* Each open-ended valve or line must be equipped with a cap, blind flange, plug, or a second valve, except as provided in paragraphs (e)(4) and (5) of this section. The cap, blind flange, plug, or second valve must seal the open end of the valve or line at all times except during operations requiring process fluid flow through the open-ended valve or line.

(1) If evidence of a leak is found at any time by AVO, or any other detection method, a leak is detected.

(2) Each open-ended valve or line equipped with a second valve must be operated in a manner such that the valve on the process fluid end is closed before the second valve is closed.

(3) When a double block-and-bleed system is being used, the bleed valve or line may remain open during operations that require venting the line between the block valves but shall remain closed at all other times.

(4) Open-ended valves or lines in an emergency shutdown system which are designed to open automatically in the event of a process upset are exempt from the requirements of this section.

(5) Open-ended valves or lines containing materials which would autocatalytically polymerize or would present an explosion, serious overpressure, or other safety hazard if capped or equipped with a double

block-and-bleed system as specified in paragraphs (e) introductory text, (e)(2), and (3) of this section are exempt from the requirements of this section.

(f) *Closed vent systems and control devices.* Closed vent systems used to comply with the equipment leak provisions of this section must comply with the requirements in §§ 60.5411b and 60.5416b. Control devices used to comply with the equipment leak provisions of this section must comply with the requirements in §§ 60.5412b, 60.5415b(f), and 60.5417b.

(g) *Pumps, valves, and connectors in heavy liquid service and pressure relief devices in light liquid or heavy liquid service.* If evidence of a potential leak is found at any time by AVO, or any other detection method, a leak is detected and must be repaired in accordance with paragraph (h) of this section.

(h) *Repair requirements.* When a leak is detected, you must comply with the requirements of paragraphs (h)(1) through (5) of this section, except as provided in paragraph (h)(6) of this section.

(1) A weatherproof and readily visible identification tag, marked with the equipment identification number, must be attached to the leaking equipment. The identification tag on equipment may be removed after it has been repaired.

(2) A first attempt at repair must be made as soon as practicable, but no later than 5 calendar days after the leak is detected. A first attempt at repair is not required if the leak is detected using OGI and the equipment identified as leaking would require elevating the repair personnel more than 2 meters above a support surface.

(i) First attempts at repair for pumps in light liquid or heavy liquid service include, but are not limited to, the practices described in paragraphs (h)(2)(i)(A) and (B) of this section, where practicable.

(A) Tightening the packing gland nuts.

(B) Ensuring that the seal flush is operating at design pressure and temperature.

(ii) For each valve where a leak is detected, you must comply with (h)(2)(ii)(A), (B) or (C), and (D) of this section.

(A) Repack the existing valve with a low-e packing.

(B) Replace the existing valve with a low-e valve; or

(C) Perform a drill and tap repair with a low-e injectable packing.

(D) An owner or operator is not required to utilize a low-e valve or low-e packing to replace or repack a valve if the owner or operator demonstrates

that a low-e valve or low-e packing is not technically feasible. Low-e valve or low-e packing that is not suitable for its intended use is considered to be technically infeasible. Factors that may be considered in determining technical infeasibility include: retrofit requirements for installation (*e.g.*, re-piping or space limitation), commercial unavailability for valve type, or certain instrumentation assemblies.

(3) Repair of leaking equipment must be completed within 15 calendar days after detection of each leak, except as provided in paragraphs (h)(4), (5) and (6) of this section.

(4) If the repair for visual indications of liquids dripping for pumps in light liquid service can be made by eliminating visual indications of liquids dripping, you must make the repair within 5 calendar days of detection.

(5) If the repair for AVO or other indication of a leak for open-ended valves or lines; pumps, valves, or connectors in heavy liquid service; or pressure relief devices in light liquid or heavy liquid service can be made by eliminating the AVO, or other indication of a potential leak, you must make the repair within 5 calendar days of detection.

(6) Delay of repair of equipment for which leaks have been detected is allowed if repair within 15 days is technically infeasible without a process unit shutdown or as specified in paragraphs (h)(6)(i) through (v) of this section. Repair of this equipment shall occur before the end of the next process unit shutdown. Monitoring to verify repair must occur within 15 days after startup of the process unit.

(i) Delay of repair of equipment is allowed for equipment which is isolated from the process, and which does not have the potential to emit methane or VOC.

(ii) Delay of repair for valves and connectors is allowed if the conditions in paragraphs (h)(6)(ii)(A) and (B) of this section are met.

(A) You must demonstrate that emissions of purged material resulting from immediate repair are greater than the fugitive emissions likely to result from delay of repair, and

(B) When repair procedures are conducted, the purged material is collected and destroyed or recovered in a control device complying with paragraph (f) of this section.

(iii) Delay of repair for pumps is allowed if the conditions in paragraphs (h)(6)(iii)(A) and (B) of this section are met.

(A) Repair requires the use of a dual mechanical seal system that includes a barrier fluid system, and

(B) Repair is completed as soon as practicable, but not later than 6 months after the leak was detected.

(iv) If delay of repair is required to repack or replace the valve, you may use delay of repair. Delay of repair beyond a process unit shutdown is allowed for a valve, if valve assembly replacement is necessary during the process unit shutdown, valve assembly supplies have been depleted, and valve assembly supplies had been sufficiently stocked before the supplies were depleted. Delay of repair beyond the next process unit shutdown will not be allowed unless the next process unit shutdown occurs sooner than 6 months after the first process unit shutdown.

(v) When delay of repair is allowed for a leaking pump, valve, or connector that remains in service, the pump, valve, or connector may be considered to be repaired and no longer subject to delay of repair requirements if two consecutive bimonthly monitoring results show no leak remains.

(i) *Initial compliance.* You must demonstrate initial compliance with the standards that apply to equipment leaks at onshore natural gas processing plants as required by § 60.5410b(h).

(j) *Continuous compliance.* You must demonstrate continuous compliance with the standards that apply to equipment leaks at onshore natural gas processing plants as required by § 60.5415b(j).

(k) *Reporting.* You must perform the reporting requirements as specified in § 60.5420b(b)(1) and (11) and § 60.5422b.

(l) *Recordkeeping.* You must perform the recordkeeping requirements as specified in § 60.5420b(c)(8), (10), and (12) and § 60.5421b.

§ 60.5401b What are the alternative GHG and VOC standards for process unit equipment affected facilities?

This section provides alternative standards for process unit equipment affected facilities located at an onshore natural gas processing plant. You may choose to comply with the standards in this section instead of the requirements in § 60.5400b. For purposes of the alternative standards provided in this section, you must comply with the requirements of paragraphs (a) through (m) of this section to reduce methane and VOC emissions from equipment leaks, except as provided in § 60.5402b.

(a) *General standards.* You must comply with the requirements in paragraphs (b) of this section for each pump in light liquid service. You must comply with the requirements of paragraph (c) of this section for each pressure relief device in gas/vapor

service. You must comply with the requirements in paragraph (d) of this section for each open-ended valve or line. You must comply with the requirements in paragraph (e) of this section for each closed vent system and control device used to comply with equipment leak provisions in this section. You must comply with paragraph (f) of this section for each valve in gas/vapor or light liquid service. You must comply with paragraph (g) of this section for each pump, valve, and connector in heavy liquid service and pressure relief device in light liquid or heavy liquid service. You must comply with paragraph (h) of this section for each connector in gas/vapor and light liquid service. You must make repairs as specified in paragraph (i) of this section. You must demonstrate initial compliance with the standards as specified in paragraph (j) of this section. You must demonstrate continuous compliance with the standards as specified in paragraph (k) of this section. You must perform the reporting requirements as specified in paragraph (l) of this section. You must perform the recordkeeping requirements as required in paragraph (m) of this section.

(1) You may apply to the Administrator for permission to use an alternative means of emission limitation that achieves a reduction in emissions of methane and VOC at least equivalent to that achieved by the controls required in this subpart according to the requirements of § 60.5399b.

(2) Each piece of equipment is presumed to have the potential to emit methane or VOC unless an owner or operator demonstrates that the piece of equipment does not have the potential to emit methane or VOC. For a piece of equipment to be considered not to have the potential to emit methane or VOC, the methane and VOC content of a gaseous stream must be below detection limits using Method 18 of appendix A-6 to this part. Alternatively, if the piece of equipment is in wet gas service, you may choose to determine the methane and VOC content of the stream is below the detection limit of the methods described in ASTM E168-16(R2023), E169-16(R2022), or E260-96 (all incorporated by reference, see § 60.17).

(b) *Pumps in light liquid service.* You must monitor each pump in light liquid service monthly to detect leaks by the methods specified in § 60.5403b, except as provided in paragraphs (b)(2) through (4) of this section. A leak is defined as an instrument reading of 2,000 ppmv or greater. A pump that begins operation in light liquid service after the initial startup date for the process unit must be monitored for the first time within 30

days after the end of its startup period, except for a pump that replaces a leaking pump and except as provided in paragraphs (b)(2) through (4) of this section.

(1) In addition to the requirements in paragraph (b) of this section, you must conduct weekly visual inspections of all pumps in light liquid service for indications of liquids dripping from the pump seal. If there are indications of liquids dripping from the pump seal, you must follow the procedure specified in either paragraph (b)(1)(i) or (ii) of this section.

(i) Monitor the pump within 5 days using the methods specified in § 60.5403b. A leak is defined as an instrument reading of 2,000 ppmv or greater.

(ii) Designate the visual indications of liquids dripping as a leak, and repair the leak as specified in paragraph (i) of this section.

(2) Each pump equipped with a dual mechanical seal system that includes a barrier fluid system is exempt from the requirements in paragraph (b) of this section, provided the requirements specified in paragraphs (b)(2)(i) through (vi) of this section are met.

(i) Each dual mechanical seal system meets the requirements of paragraphs (b)(2)(i)(A), (B), or (C) of this section.

(A) Operated with the barrier fluid at a pressure that is at all times greater than the pump stuffing box pressure; or

(B) Equipped with a barrier fluid degassing reservoir that is routed to a process or fuel gas system or connected by a closed vent system to a control device that complies with the requirements of paragraph (e) of this section; or

(C) Equipped with a system that purges the barrier fluid into a process stream with zero VOC emissions to the atmosphere.

(ii) The barrier fluid system is in heavy liquid service or does not have the potential to emit methane or VOC.

(iii) Each barrier fluid system is equipped with a sensor that will detect failure of the seal system, the barrier fluid system, or both.

(iv) Each pump is checked according to the requirements in paragraph (b)(1) of this section.

(v) Each sensor meets the requirements in paragraphs (b)(2)(v)(A) through (C) of this section.

(A) Each sensor as described in paragraph (b)(2)(iii) of this section is checked daily or is equipped with an audible alarm.

(B) You determine, based on design considerations and operating experience, a criterion that indicates

failure of the seal system, the barrier fluid system, or both.

(C) If the sensor indicates failure of the seal system, the barrier fluid system, or both, based on the criterion established in paragraph (b)(2)(v)(B) of this section, a leak is detected.

(3) Any pump that is designated, as described in § 60.5421b(b)(12), for no detectable emissions, as indicated by an instrument reading of less than 500 ppmv above background, is exempt from the requirements of paragraphs (b) introductory text, (b)(1), and (2) of this section if the pump:

(i) Has no externally actuated shaft penetrating the pump housing;

(ii) Is demonstrated to be operating with no detectable emissions as indicated by an instrument reading of less than 500 ppmv above background as measured by the methods specified in § 60.5403b; and

(iii) Is tested for compliance with paragraph (b)(3)(ii) of this section initially upon designation, annually, and at other times requested by the Administrator.

(4) If any pump is equipped with a closed vent system capable of capturing and transporting any leakage from the seal or seals to a process, fuel gas system, or a control device that complies with the requirements of paragraph (e) of this section, it is exempt from paragraphs (b), (b)(1) through (3) of this section, and the repair requirements of paragraph (i) of this section.

(5) Any pump that is designated, as described in § 60.5421b(b)(13), as an unsafe-to-monitor pump is exempt from the inspection and monitoring requirements of paragraphs (b), (b)(1) and (b)(2)(iv) through (vi) of this section if the conditions in paragraph (b)(5)(i) and (ii) of this section are met.

(i) You demonstrate that the pump is unsafe-to-monitor because monitoring personnel would be exposed to an immediate danger as a consequence of complying with paragraph (b) of this section; and

(ii) You have a written plan that requires monitoring of the pump as frequently as practicable during safe-to-monitor times, but not more frequently than the periodic monitoring schedule otherwise applicable, and you repair the equipment according to the procedures in paragraph (i) of this section if a leak is detected.

(6) Any pump that is located within the boundary of an unmanned plant site is exempt from the weekly visual inspection requirements in paragraph (b)(1) and (b)(2)(iv) of this section, and the daily requirements of paragraph (b)(2)(v) of this section, provided that

each pump is visually inspected as often as practicable and at least monthly.

(c) *Pressure relief devices in gas/vapor service.* You must monitor each pressure relief device quarterly using the methods specified in § 60.5403b. A leak is defined as an instrument reading of 500 ppmv or greater above background.

(1) In addition to the requirements in paragraph (c) introductory text of this section, after each pressure release, you must monitor each pressure relief device within 5 calendar days after each pressure release to detect leaks. A leak is detected if an instrument reading of 500 ppmv or greater is provided using the methods specified in § 60.5403b(b).

(2) Any pressure relief device that is located in a nonfractionating plant that is monitored only by non-plant personnel may be monitored after a pressure release the next time the monitoring personnel are onsite or within 30 calendar days after a pressure release, whichever is sooner, instead of within 5 calendar days as specified in paragraph (c)(1) of this section.

(3) No pressure relief device described in paragraph (c)(2) of this section may be allowed to operate for more than 30 calendar days after a pressure release without monitoring.

(4) Any pressure relief device that is routed to a process or fuel gas system or equipped with a closed vent system capable of capturing and transporting leakage through the pressure relief device to a control device as described in paragraph (e) of this section is exempt from the requirements of paragraph (c) introductory text and (c)(1) of this section.

(5) Pressure relief devices equipped with a rupture disk are exempt from the requirements of paragraphs (c)(1) and (2) of this section provided you install a new rupture disk upstream of the pressure relief device as soon as practicable, but no later than 5 calendar days after each pressure release, except as provided in paragraph (i)(4) of this section.

(d) *Open-ended valves or lines.* Each open-ended valve or line must be equipped with a cap, blind flange, plug, or a second valve, except as provided in paragraphs (d)(4) and (5) of this section. The cap, blind flange, plug, or second valve must seal the open end of the valve or line at all times except during operations requiring process fluid flow through the open-ended valve or line.

(1) If evidence of a leak is found at any time by AVO, or any other detection method, a leak is detected and must be repaired in accordance with paragraph (i) of this section. A leak is defined as an instrument reading of 500 ppmv or

greater if Method 21 of appendix A-7 to this part is used.

(2) Each open-ended valve or line equipped with a second valve must be operated in a manner such that the valve on the process fluid end is closed before the second valve is closed.

(3) When a double block-and-bleed system is being used, the bleed valve or line may remain open during operations that require venting the line between the block valves but shall remain closed at all other times.

(4) Open-ended valves or lines in an emergency shutdown system which are designed to open automatically in the event of a process upset are exempt from the requirements of paragraphs (d) introductory text, and (d)(1) through (3) of this section.

(5) Open-ended valves or lines containing materials which would autocatalytically polymerize or would present an explosion, serious overpressure, or other safety hazard if capped or equipped with a double block-and-bleed system as specified in paragraphs (d) introductory text, (d)(2), and (3) of this section are exempt from the requirements of this section.

(e) *Closed vent systems and control devices.* Closed vent systems used to comply with the equipment leak provisions of this section must comply with the requirements in §§ 60.5411b and 60.5416b. Control devices used to comply with the equipment leak provisions of this section must comply with the requirements in §§ 60.5412b, 60.5415b(f), and 60.5417b.

(f) *Valves in gas/vapor and light liquid service.* You must monitor each valve in gas/vapor and in light liquid service quarterly to detect leaks by the methods specified in § 60.5403b, except as provided in paragraphs (h)(3) through (5) of this section.

(1) A valve that begins operation in gas/vapor service or in light liquid service after the initial startup date for the process unit must be monitored for the first time within 90 days after the end of its startup period to ensure proper installation, except for a valve that replaces a leaking valve and except as provided in paragraphs (h)(3) through (5) of this section.

(2) An instrument reading of 500 ppmv or greater is a leak. You must repair each leaking valve according to the requirements in paragraph (i) of this section.

(3) Any valve that is designated, as described in § 60.5421b(b)(12), for no detectable emissions, as indicated by an instrument reading of less than 500 ppmv above background, is exempt from the requirements of paragraphs (f) of this section if the valve:

(i) Has no externally actuating mechanism in contact with the process fluid;

(ii) Is operated with emissions less than 500 ppmv above background as determined by the methods specified in § 60.5403b; and

(iii) Is tested for compliance with paragraph (f)(3)(ii) of this section initially upon designation, annually, and at other times requested by the Administrator.

(4) Any valve that is designated, as described in § 60.5421b(b)(13), as an unsafe-to-monitor pump is exempt from the monitoring requirements of paragraph (f) introductory text of this section if the requirements in paragraphs (f)(4)(i) and (ii) of this section are met.

(i) You demonstrate that the valve is unsafe-to-monitor because monitoring personnel would be exposed to an immediate danger as a consequence of complying with paragraph (f) of this section; and

(ii) You have a written plan that requires monitoring of the valve as frequently as practicable during safe-to-monitor times, but not more frequently than the periodic monitoring schedule otherwise applicable, and you repair the equipment according to the procedures in paragraph (i) of this section if a leak is detected.

(5) Any valve that is designated, as described in § 60.5421b(b)(14), as a difficult-to-monitor valve is exempt from the monitoring requirements of paragraph (h) of this section if the requirements in paragraph (f)(5)(i) through (iii) of this section are met.

(i) You demonstrate that the valve cannot be monitored without elevating the monitoring personnel more than 2 meters above a support surface.

(ii) The process unit within which the valve is located has less than 3.0 percent of its total number of valves designated as difficult-to-monitor.

(iii) You have a written plan that requires monitoring of the at least once per calendar year.

(g) *Pumps, valves, and connectors in heavy liquid service and pressure relief devices in light liquid or heavy liquid service.* If evidence of a potential leak is found at any time by AVO, or any other detection method, you must comply with either paragraph (g)(1) or (2) of this section.

(1) You must monitor the equipment within 5 calendar days by the method specified in § 60.5403b and repair any leaks detected according to paragraph (i) of this section. An instrument reading of 10,000 ppmv or greater is defined as a leak.

(2) You must designate the AVO, or other indication of a leak as a leak and repair the leak according to paragraph (i) of this section.

(h) *Connectors in gas/vapor service and in light liquid service.* You must initially monitor all connectors in the process unit for leaks by the later of either 12 months after the compliance date or 12 months after initial startup. If all connectors in the process unit have been monitored for leaks prior to the compliance date, no initial monitoring is required provided either no process changes have been made since the monitoring or the owner or operator can determine that the results of the monitoring, with or without adjustments, reliably demonstrate compliance despite process changes. If required to monitor because of a process change, you are required to monitor only those connectors involved in the process change.

(1) You must monitor all connectors in gas/vapor service and in light liquid service annually, except as provided in § 60.5399b, paragraph (e) of this section or paragraph (h)(2) of this section.

(2) Any connector that is designated, as described in § 60.5421b(b)(13), as an unsafe-to-monitor connector is exempt from the requirements of paragraphs (h) introductory text and (h)(1) of this section if the requirements of paragraphs (h)(2)(i) and (ii) of this section are met.

(i) You demonstrate the connector is unsafe-to-monitor because monitoring personnel would be exposed to an immediate danger as a consequence of complying with paragraphs (h) introductory text and (h)(1) of this section; and

(ii) You have a written plan that requires monitoring of the connector as frequently as practicable during safe-to-monitor times, but not more frequently than the periodic monitoring schedule otherwise applicable, and you repair the equipment according to the procedures in paragraph (i) of this section if a leak is detected.

(3) Inaccessible, ceramic, or ceramic-line connectors.

(i) Any connector that is inaccessible or that is ceramic or ceramic-lined (*e.g.*, porcelain, glass, or glass-lined), is exempt from the monitoring requirements of paragraphs (h) and (h)(1) of this section, from the leak repair requirements of paragraph (i) of this section, and from the recordkeeping and reporting requirements of §§ 60.5421b and 60.5422b. An inaccessible connector is one that meets any of the specifications in paragraphs (h)(3)(i)(A) through (F) of this section, as applicable.

(A) Buried.

(B) Insulated in a manner that prevents access to the connector by a monitor probe.

(C) Obstructed by equipment or piping that prevents access to the connector by a monitor probe.

(D) Unable to be reached from a wheeled scissor-lift or hydraulic-type scaffold that would allow access to connectors up to 7.6 meters (25 feet) above the ground.

(E) Inaccessible because it would require elevating monitoring personnel more than 2 meters (7 feet) above a permanent support surface or would require the erection of scaffold.

(F) Not able to be accessed at any time in a safe manner to perform monitoring. Unsafe access includes, but is not limited to, the use of a wheeled scissor-lift on unstable or uneven terrain, the use of a motorized man-lift basket in areas where an ignition potential exists, or access would require near proximity to hazards such as electrical lines or would risk damage to equipment.

(ii) If any inaccessible, ceramic, or ceramic-lined connector is observed by AVO or other means to be leaking, the indications of a leak to the atmosphere by AVO or other means must be eliminated as soon as practicable.

(4) Connectors which are part of an instrumentation systems and inaccessible, ceramic, or ceramic-lined connectors meeting the provisions of paragraph (h)(3) of this section, are not subject to the recordkeeping requirements of § 60.5421b(b)(1).

(i) *Repair requirements.* When a leak is detected, comply with the requirements of paragraphs (i)(1) through (5) of this section, except as provided in paragraph (i)(6) of this section.

(1) A weatherproof and readily visible identification tag, marked with the equipment identification number, must be attached to the leaking equipment. The identification tag on the equipment may be removed after it has been repaired.

(2) A first attempt at repair must be made as soon as practicable, but no later than 5 calendar days after the leak is detected.

(i) First attempts at repair for pumps in light liquid or heavy liquid service include, but are not limited to, the practices described in paragraphs (i)(2)(i)(A) and (B) of this section, where practicable.

(A) Tightening the packing gland nuts.

(B) Ensuring that the seal flush is operating at design pressure and temperature.

(ii) For each valve where a leak is detected, you must comply with (h)(2)(ii)(A), (B) or (C), and (D) of this section.

(A) Repack the existing valve with a low-e packing.

(B) Replace the existing valve with a low-e valve; or

(C) Perform a drill and tap repair with a low-e injectable packing.

(D) An owner or operator is not required to utilize a low-e valve or low-e packing to replace or repack a valve if the owner or operator demonstrates that a low-e valve or low-e packing is not technically feasible. Low-e valve or low-e packing that is not suitable for its intended use is considered to be technically infeasible. Factors that may be considered in determining technical infeasibility include: retrofit requirements for installation (*e.g.*, re-piping or space limitation), commercial unavailability for valve type, or certain instrumentation assemblies.

(3) Repair of leaking equipment must be completed within 15 calendar days after detection of each leak, except as provided in paragraph (i)(4), (5), or (6) of this section.

(4) If the repair for visual indications of liquids dripping for pumps in light liquid service can be made by eliminating visual indications of liquids dripping, you must make the repair within 5 calendar days of detection.

(5) If the repair for AVO or other indication of a leak for open-ended lines or valves; pumps, valves, or connectors in heavy liquid service; or pressure relief devices in light liquid or heavy liquid service can be made by eliminating the AVO, or other indication of a potential leak, you must make the repair within 5 calendar days of detection.

(6) Delay of repair of equipment for which leaks have been detected will be allowed if repair within 15 calendar days is technically infeasible without a process unit shutdown or as specified in paragraphs (i)(6)(i) through (v) of this section. Repair of this equipment shall occur before the end of the next process unit shutdown. Monitoring to verify repair must occur within 15 calendar days after startup of the process unit.

(i) Delay of repair of equipment will be allowed for equipment which is isolated from the process, and which does not have the potential to emit methane or VOC.

(ii) Delay of repair for valves and connectors will be allowed if the conditions in paragraphs (i)(6)(ii)(A) and (B) are met.

(A) You demonstrate that emissions of purged material resulting from immediate repair are greater than the

fugitive emissions likely to result from delay of repair, and

(B) When repair procedures are conducted, the purged material is collected and destroyed or recovered in a control device complying with paragraph (e) of this section.

(iii) Delay of repair for pumps will be allowed if the conditions in paragraphs (i)(6)(iii)(A) and (B) are met.

(A) Repair requires the use of a dual mechanical seal system that includes a barrier fluid system, and

(B) Repair is completed as soon as practicable, but not later than 6 months after the leak was detected.

(iv) If delay of repair is required to repack or replace the valve, you may use delay of repair. Delay of repair beyond a process unit shutdown will be allowed for a valve, if valve assembly replacement is necessary during the process unit shutdown, valve assembly supplies have been depleted, and valve assembly supplies had been sufficiently stocked before the supplies were depleted. Delay of repair beyond the next process unit shutdown will not be allowed unless the next process unit shutdown occurs sooner than 6 months after the first process unit shutdown.

(v) When delay of repair is allowed for a leaking pump, valve, or connector that remains in service, the pump, valve, or connector may be considered to be repaired and no longer subject to delay of repair requirements if two consecutive monthly monitoring results show no leak remains.

(j) *Initial compliance.* You must demonstrate initial compliance with the standards that apply to equipment leaks at onshore natural gas processing plants as required by § 60.5410b(h).

(k) *Continuous compliance.* You must demonstrate continuous compliance with the standards that apply to equipment leaks at onshore natural gas processing plants as required by § 60.5415b(j).

(l) *Reporting.* You must perform the reporting requirements as specified in §§ 60.5420b(b)(1), (b)(11), and 60.5422b.

(m) *Recordkeeping.* You must perform the recordkeeping requirements as specified in § 60.5420b(c)(8), (10), (12), and § 60.5421b.

§ 60.5402b What are the exceptions to the GHG and VOC standards for process unit equipment affected facilities?

(a) You may comply with the following exceptions to the provisions of §§ 60.5400b(a) and 60.5401b(a), as applicable.

(b) Pumps in light liquid service, pressure relief devices in gas/vapor service, valves in gas/vapor and light liquid service, and connectors in gas/

vapor service and in light liquid service that are located at a nonfractionating plant that does not have the design capacity to process 283,200 standard cubic meters per day (scmd) (10 million standard cubic feet per day) or more of field gas may comply with the exceptions specified in paragraphs (b)(1) or (2) of this section.

(1) You are exempt from the bimonthly OGI monitoring as required under § 60.5400b(b).

(2) You are exempt from the routine Method 21 of appendix A–7 monitoring requirements of § 60.5401b(b), (c), (f), and (h), if complying with the alternative standards of § 60.5401b.

(c) Pumps in light liquid service, pressure relief devices in gas/vapor service, valves in gas/vapor and light liquid service, and connectors in gas/vapor service and in light liquid service within a process unit that is located in the Alaskan North Slope are exempt from the monitoring requirements § 60.5400b(b) and (c) and § 60.5401b(b), (c), (f) and (h).

(d) You may use the following provisions instead of § 60.5403b(e):

(1) Equipment is in heavy liquid service if the weight percent evaporated is 10 percent or less at 150 degrees Celsius (302 degrees Fahrenheit) as determined by ASTM D86–96 (incorporated by reference, see § 60.17).

(2) Equipment is in light liquid service if the weight percent evaporated is greater than 10 percent at 150 degrees Celsius (302 degrees Fahrenheit) as determined by ASTM D86–96 (incorporated by reference, see § 60.17).

(e) Equipment that is in vacuum service, except connectors in gas/vapor and light liquid service, is excluded from the requirements of § 60.5400b(b) through (g), if it is identified as required in § 60.5421b(b)(15). Equipment that is in vacuum service is excluded from the requirements of § 60.5401b(b) through (g) if it is identified as required in § 60.5421b(b)(15).

(f) Equipment that you designate as having the potential to emit methane or VOC less than 300 hr/yr is excluded from the requirements of § 60.5400b(b) through (g) and § 60.5401b(b) through (h), if it is identified as required in § 60.5421b(b)(16) and it meets any of the conditions specified in paragraphs (f)(1) through (3) of this section.

(1) The equipment has the potential to emit methane or VOC only during startup and shutdown.

(2) The equipment has the potential to emit methane or VOC only during process malfunctions or other emergencies.

(3) The equipment is backup equipment that has the potential to emit

methane or VOC only when the primary equipment is out of service.

§ 60.5403b What test methods and procedures must I use for my process unit equipment affected facilities?

(a) In conducting the performance tests required in § 60.8, you must use as reference methods and procedures the test methods in appendix A to this part or other methods and procedures as specified in this section, except as provided in § 60.8(b).

(b) You must determine compliance with the standards in § 60.5401b as follows:

(1) Method 21 of appendix A–7 to this part shall be used to determine the presence of leaking sources. The instrument shall be calibrated before use each day of its use by the procedures specified in Method 21 of appendix A–7 to this part. The following calibration gases shall be used:

(i) Zero air (less than 10 ppmv of hydrocarbon in air); and

(ii) A mixture of methane or n-hexane and air at a concentration no more than 2,000 ppmv greater than the leak definition concentration of the equipment monitored. If the monitoring instrument's design allows for multiple calibration scales, then the lower scale shall be calibrated with a calibration gas that is no higher than 2,000 ppmv above the concentration specified as a leak, and the highest scale shall be calibrated with a calibration gas that is approximately or equal to 10,000 ppmv. If only one scale on an instrument will be used during monitoring, you need not calibrate the scales that will not be used during that day's monitoring.

(iii) Verification that your monitoring equipment meets the requirements specified in Section 6.0 of Method 21 of appendix A–7 to this part. For purposes of instrument capability, the leak definition shall be 500 ppmv or greater methane using a FID-based instrument for valves and connectors and 2,000 ppmv methane or greater for pumps. If you wish to use an analyzer other than a FID-based instrument, you must develop a site-specific leak definition that would be equivalent to 500 ppmv methane using a FID-based instrument (e.g., 10.6 eV PID with a specified isobutylene concentration as the leak definition would provide equivalent response to your compound of interest).

(2) The instrument must be calibrated before use each day of its use by the procedures specified in Method 21 of appendix A–7 to this part. At minimum, you must also conduct precision tests at the interval specified in Method 21 of appendix A–7 to this part, Section 8.1.2, and a calibration drift assessment at the

end of each monitoring day. The calibration drift assessment must be conducted as specified in paragraph (b)(2)(i) of this section. Corrective action for drift assessments is specified in paragraphs (b)(2)(ii) and (iii) of this section.

(i) Check the instrument using the same calibration gas that was used to calibrate the instrument before use. Follow the procedures specified in Method 21 of appendix A-7 to this part, Section 10.1, except do not adjust the meter readout to correspond to the calibration gas value. If multiple scales are used, record the instrument reading for each scale used. Divide the arithmetic difference of the initial and post-test calibration response by the corresponding calibration gas value for each scale and multiply by 100 to express the calibration drift as a percentage.

(ii) If a calibration drift assessment shows a negative drift of more than 10 percent, then all equipment with instrument readings between the fugitive emission definition multiplied by (100 minus the percent of negative drift) divided by 100 and the fugitive emission definition that was monitored since the last calibration must be re-monitored.

(iii) If any calibration drift assessment shows a positive drift of more than 10 percent from the initial calibration value, then, at the owner/operator's discretion, all equipment with instrument readings above the fugitive emission definition and below the fugitive emission definition multiplied by (100 plus the percent of positive drift) divided by 100 monitored since the last calibration may be re-monitored.

(c) You shall determine compliance with the no detectable emission

standards in § 60.5401b(b), (c), and (f) as specified in paragraphs (c)(1) and (2) of this section.

(1) The requirements of paragraph (b) of this section shall apply.

(2) Method 21 of appendix A-7 to this part shall be used to determine the background level. All potential leak interfaces shall be traversed as close to the interface as possible. The arithmetic difference between the maximum concentration indicated by the instrument and the background level is compared with 500 ppmv for determining compliance.

(d) You shall demonstrate that a piece of equipment is in light liquid service by showing that all of the following conditions apply:

(1) The vapor pressure of one or more of the organic components is greater than 0.3 kPa at 20 °C (1.2 in H₂O at 68 °F). Standard reference texts or ASTM D2879-83, -96, or -97 (all incorporated by reference, see § 60.17) shall be used to determine the vapor pressures.

(2) The total concentration of the pure organic components having a vapor pressure greater than 0.3 kPa at 20 °C (1.2 in H₂O at 68 °F) is equal to or greater than 20 percent by weight.

(3) The fluid is a liquid at operating conditions.

(e) Samples used in conjunction with paragraphs (d) and (e) of this section shall be representative of the process fluid that is contained in or contacts the equipment, or the gas being combusted in the flare.

§ 60.5405b What standards apply to sweetening unit affected facilities?

(a) During the initial performance test required by § 60.8(b), you must achieve at a minimum, an SO₂ emission

reduction efficiency (Z_i) to be determined from table 3 to this subpart based on the sulfur feed rate (X) and the sulfur content of the acid gas (Y) of the affected facility.

(b) After demonstrating compliance with the provisions of paragraph (a) of this section, you must achieve at a minimum, an SO₂ emission reduction efficiency (Z_c) to be determined from table 4 to this subpart based on the sulfur feed rate (X) and the sulfur content of the acid gas (Y) of the affected facility.

(c) You must demonstrate initial compliance with the standards that apply to sweetening unit affected facilities as required by § 60.5410b(i).

(d) You must demonstrate continuous compliance with the standards that apply to sweetening unit affected facilities as required by § 60.5415b(k).

(e) You must perform the reporting as required by § 60.5420b(a)(1), (b)(1), and § 60.5423b and the recordkeeping as required by § 60.5423b.

§ 60.5406b What test methods and procedures must I use for my sweetening unit affected facilities?

(a) In conducting the performance tests required in § 60.8, you must use the test methods in appendix A to this part or other methods and procedures as specified in this section, except as provided in § 60.8(b).

(b) During a performance test required by § 60.8, you must determine the minimum required reduction efficiencies (Z) of SO₂ emissions as required in § 60.5405b(a) and (b) as follows:

(1) The average sulfur feed rate (X) must be computed as follows:

Equation 1 to paragraph (b)(1)

$$X = KQ_aY$$

Where:

X = average sulfur feed rate, Mg/D (LT/D).

Q_a = average volumetric flow rate of acid gas from sweetening unit, dscm/day (dscf/day).

Y = average H₂S concentration in acid gas feed from sweetening unit, percent by volume, expressed as a decimal.

K = (32 kg S/kg-mole)/((24.04 dscm/kg-mole)(1000 kg S/Mg)).

= 1.331 × 10⁻³ Mg/dscm, for metric units.

= (32 lb S/lb-mole)/((385.36 dscf/lb-mole)(2240 lb S/long ton)).

= 3.707 × 10⁻⁵ long ton/dscf, for English units.

(2) You must use the continuous readings from the process flowmeter to determine the average volumetric flow rate (Q_a) in dscm/day (dscf/day) of the acid gas from the sweetening unit for each run.

(3) You must use the Tutwiler procedure in § 60.5408b or a chromatographic procedure following ASTM E260-96 (incorporated by reference, see § 60.17) to determine the H₂S concentration in the acid gas feed from the sweetening unit (Y). At least one sample per hour (at equally spaced intervals) must be taken during each 4-

hour run. The arithmetic mean of all samples must be the average H₂S concentration (Y) on a dry basis for the run. By multiplying the result from the Tutwiler procedure by 1.62 × 10^{minus-3}, the units gr/100 scf are converted to volume percent.

(4) Using the information from paragraphs (b)(1) and (3) of this section, tables 3 and 4 to this subpart must be used to determine the required initial (Z_i) and continuous (Z_c) reduction efficiencies of SO₂ emissions.

(c) You must determine the emission reduction efficiency (R) achieved by the sulfur recovery technology as follows:

(1) You must compute the emission reduction efficiency (R) achieved by the

sulfur recovery technology for each run using the following equation:

Equation 2 to paragraph (c)(1)

$$R = (100S)/(S + E)$$

(2) You must use the level indicators or manual soundings to measure the liquid sulfur accumulation rate in the product storage vessels. You must use

readings taken at the beginning and end of each run, the tank geometry, sulfur density at the storage temperature, and sample duration to determine the sulfur

production rate (S) in kg/hr (lb/hr) for each run.

(3) You must compute the emission rate of sulfur for each run as follows:

Equation 3 to paragraph (c)(3)

$$E = C_e Q_{sd} / K_1$$

Where:

E = emission rate of sulfur per run, kg/hr.

C_e = concentration of sulfur equivalent (SO_2 + reduced sulfur), g/dscm (lb/dscf).

Q_{sd} = volumetric flow rate of effluent gas, dscm/hr (dscf/hr).

K_1 = conversion factor, 1000 g/kg (7000 gr/lb).

(4) The concentration (C_e) of sulfur equivalent must be the sum of the SO_2 and TRS concentrations, after being converted to sulfur equivalents. For each run and each of the test methods specified in this paragraph (c) of this section, you must use a sampling time of at least 4 hours. You must use Method 1 of appendix A–1 to this part to select the sampling site. The sampling point in the duct must be at the centroid of the cross-section if the area is less than 5 m² (54 ft²) or at a point no closer to the walls than 1 m (39 in) if the cross-sectional area is 5 m² or more, and the centroid is more than 1 m (39 in) from the wall.

(i) You must use Method 6 or 6C of appendix A–4 to this part to determine the SO_2 concentration. You must take eight samples of 20 minutes each at 30-minute intervals. The arithmetic average must be the concentration for the run. The concentration must be multiplied by 0.5×10^{-3} to convert the results to sulfur equivalent. In place of Method 6 of appendix A to this part, you may use ANSI/ASME PTC 19.10–1981, Part 10 (manual portion only) (incorporated by reference, see § 60.17).

(ii) You must use Method 2 of appendix A–1 to this part to determine the volumetric flow rate of the effluent gas. A velocity traverse must be conducted at the beginning and end of each run. The arithmetic average of the two measurements must be used to calculate the volumetric flow rate (Q_{sd}) for the run. For the determination of the

effluent gas molecular weight, a single integrated sample over the 4-hour period may be taken and analyzed or grab samples at 1-hour intervals may be taken, analyzed, and averaged.

(iii) You must use Method 4 of appendix A–2 to this part for moisture content. Alternatively, you must take two samples of at least 0.10 dscm (3.5 dscf) and 10 minutes at the beginning of the 4-hour run and near the end of the time period. The arithmetic average of the two runs must be the moisture content for the run.

(iv) You must use Method 15 of appendix A–5 to this part to determine the TRS concentration from reduction-type devices or where the oxygen content of the effluent gas is less than 1.0 percent by volume. The sampling rate must be at least 3 liters/min (0.1 ft³/min) to insure minimum residence time in the sample line. You must take sixteen samples at 15-minute intervals. The arithmetic average of all the samples must be the concentration for the run. The concentration in ppmv reduced sulfur as sulfur must be multiplied by 1.333×10^{-3} to convert the results to sulfur equivalent.

(v) You must use Method 16A of appendix A–6 to this part or ANSI/ASME PTC 19.10–1981, Part 10 (manual portion only) (incorporated by reference, see § 60.17) to determine the reduced sulfur concentration from oxidation-type devices or where the oxygen content of the effluent gas is greater than 1.0 percent by volume. You must take eight samples of 20 minutes each at 30-minute intervals. The arithmetic average must be the concentration for the run. The concentration in ppm reduced sulfur as sulfur must be multiplied by 1.333×10^{-3} to convert the results to sulfur equivalent.

(iv) You must use EPA Method 2 of appendix A–1 to this part to determine the volumetric flow rate of the effluent gas. A velocity traverse must be conducted at the beginning and end of each run. The arithmetic average of the two measurements must be used to calculate the volumetric flow rate (Q_{sd}) for the run. For the determination of the effluent gas molecular weight, a single integrated sample over the 4-hour period may be taken and analyzed or grab samples at 1-hour intervals may be taken, analyzed, and averaged. For the moisture content, you must take two samples of at least 0.10 dscm (3.5 dscf) and 10 minutes at the beginning of the 4-hour run and near the end of the time period. The arithmetic average of the two runs must be the moisture content for the run.

§ 60.5407b What are the requirements for monitoring of emissions and operations from my sweetening unit affected facilities?

(a) If your sweetening unit affected facility is subject to the provisions of § 60.5405b(a) or (b) you must install, calibrate, maintain, and operate monitoring devices or perform measurements to determine the following operations information on a daily basis:

(1) The accumulation of sulfur product over each 24-hour period. The monitoring method may incorporate the use of an instrument to measure and record the liquid sulfur production rate or may be a procedure for measuring and recording the sulfur liquid levels in the storage vessels with a level indicator or by manual soundings, with subsequent calculation of the sulfur production rate based on the tank geometry, stored sulfur density, and elapsed time between readings. The method must be designed to be accurate

within ± 2 percent of the 24-hour sulfur accumulation.

(2) The H₂S concentration in the acid gas from the sweetening unit for each 24-hour period. At least one sample per 24-hour period must be collected and analyzed using the equation specified in § 60.5406b(b)(1). The Administrator may require you to demonstrate that the H₂S concentration obtained from one or more samples over a 24-hour period is within ± 20 percent of the average of 12 samples collected at equally spaced intervals during the 24-hour period. In instances where the H₂S concentration of a single sample is not within ± 20 percent of the average of the 12 equally spaced samples, the Administrator may require a more frequent sampling schedule.

(3) The average acid gas flow rate from the sweetening unit. You must install and operate a monitoring device to continuously measure the flow rate of acid gas. The monitoring device reading must be recorded at least once per hour during each 24-hour period. The average acid gas flow rate must be computed from the individual readings.

(4) The sulfur feed rate (X). For each 24-hour period, you must compute X using the equation specified in § 60.5406b(b)(1).

(5) The required sulfur dioxide emission reduction efficiency for the 24-hour period. You must use the sulfur feed rate and the H₂S concentration in the acid gas for the 24-hour period, as applicable, to determine the required reduction efficiency in accordance with the provisions of § 60.5405b(b).

(b) Where compliance is achieved through the use of an oxidation control system or a reduction control system followed by a continually operated incineration device, you must install, calibrate, maintain, and operate monitoring devices and continuous emission monitors as follows:

(1) A continuous monitoring system to measure the total sulfur emission rate (E) of SO₂ in the gases discharged to the atmosphere. The SO₂ emission rate must be expressed in terms of equivalent sulfur mass flow rates (kg/hr (lb/hr)). The span of this monitoring system must be set so that the equivalent emission limit of § 60.5405b(b) will be between 30 percent and 70 percent of the measurement range of the instrument system.

(2) Except as provided in paragraph (b)(3) of this section: A monitoring device to measure the temperature of the gas leaving the combustion zone of the incinerator, if compliance with § 60.5405b(a) is achieved through the use of an oxidation control system or a reduction control system followed by a continually operated incineration device. The monitoring device must be certified by the manufacturer to be accurate to within ± 1 percent of the temperature being measured.

(3) When performance tests are conducted under the provision of § 60.8 to demonstrate compliance with the standards under § 60.5405b, the temperature of the gas leaving the incinerator combustion zone must be determined using the monitoring device. If the volumetric ratio of sulfur dioxide to sulfur dioxide plus total reduced sulfur (expressed as SO₂) in the gas leaving the incinerator is equal to or less than 0.98, then temperature monitoring may be used to demonstrate that sulfur dioxide emission monitoring is sufficient to determine total sulfur emissions. At all times during the operation of the facility, you must maintain the average temperature of the gas leaving the combustion zone of the incinerator at or above the appropriate level determined during the most recent performance test to ensure the sulfur compound oxidation criteria are met. Operation at lower average temperatures may be considered by the Administrator to be unacceptable operation and maintenance of the affected facility. You may request that the minimum incinerator temperature be reestablished by conducting new performance tests under § 60.8.

(4) Upon promulgation of a performance specification of continuous monitoring systems for total reduced sulfur compounds at sulfur recovery plants, you may, as an alternative to paragraph (b)(2) of this section, install, calibrate, maintain, and operate a continuous emission monitoring system for total reduced sulfur compounds as required in paragraph (d) of this section in addition to a sulfur dioxide emission monitoring system. The sum of the equivalent sulfur mass emission rates from the two monitoring systems must be used to compute the total sulfur emission rate (E).

(c) Where compliance is achieved using a reduction control system not followed by a continually operated incineration device, you must install, calibrate, maintain, and operate a continuous monitoring system to measure the emission rate of reduced sulfur compounds as SO₂ equivalent in the gases discharged to the atmosphere. The SO₂ equivalent compound emission rate must be expressed in terms of equivalent sulfur mass flow rates (kg/hr (lb/hr)). The span of this monitoring system must be set so that the equivalent emission limit of § 60.5405b(b) will be between 30 and 70 percent of the measurement range of the system. This requirement becomes effective upon promulgation of a performance specification for continuous monitoring systems for total reduced sulfur compounds at sulfur recovery plants.

(d) For those sources required to comply with paragraph (b) or (c) of this section, you must calculate the average sulfur emission reduction efficiency achieved (R) for each 24-hour clock interval. The 24-hour interval may begin and end at any selected clock time but must be consistent. You must compute the 24-hour average reduction efficiency (R) based on the 24-hour average sulfur production rate (S) and sulfur emission rate (E), using the equation in § 60.5406b(c)(1).

(1) You must use data obtained from the sulfur production rate monitoring device specified in paragraph (a) of this section to determine S.

(2) You must use data obtained from the sulfur emission rate monitoring systems specified in paragraphs (b) or (c) of this section to calculate a 24-hour average for the sulfur emission rate (E). The monitoring system must provide at least one data point in each successive 15-minute interval. You must use at least two data points to calculate each 1-hour average. You must use a minimum of 18 1-hour averages to compute each 24-hour average.

(e) In lieu of complying with paragraphs (b) or (c) of this section, those sources with a design capacity of less than 152 Mg/D (150 LT/D) of H₂S expressed as sulfur may calculate the sulfur emission reduction efficiency achieved for each 24-hour period by:

Equation 1 to paragraph (e)

$$R = \frac{K_2 S}{X}$$

Where:

R = The sulfur dioxide removal efficiency achieved during the 24-hour period, percent.

K_2 = Conversion factor, 0.02400 Mg/D per kg/hr (0.01071 LT/D per lb/hr).

S = The sulfur production rate during the 24-hour period, kg/hr (lb/hr).

X = The sulfur feed rate in the acid gas, Mg/D (LT/D).

(f) The monitoring devices required in paragraphs (b)(1) and (3) and (c) of this section must be calibrated at least annually according to the manufacturer's specifications, as required by § 60.13(b).

(g) The continuous emission monitoring systems required in paragraphs (b)(1) and (3), and (c) of this section must be subject to the emission monitoring requirements of § 60.13. For conducting the continuous emission monitoring system performance evaluation required by § 60.13(c), Performance Specification 2 of appendix B to this part must apply, and Method 6 of appendix A-4 to this part must be used for systems required by paragraph (b) of this section. In place of Method 6 of appendix A-4 to this part, ASME PTC 19.10-1981 (incorporated by reference, see § 60.17) may be used.

§ 60.5408b What is an optional procedure for measuring hydrogen sulfide in acid gas—Tutwiler Procedure?

The Tutwiler procedure may be found in the Gas Engineers Handbook, Fuel Gas Engineering practices, The Industrial Press, 93 Worth Street, New York, NY, 1966, First Edition, Second

Printing, page 6/25 (Docket A-80-20-A, Entry II-1-67).

(a) *Sampling.* When an instantaneous sample is desired and H₂S concentration is 10 grains per 1000 cubic foot or more, a 100 ml Tutwiler burette is used. For concentrations less than 10 grains, a 500 ml Tutwiler burette and more dilute solutions are used. In principle, this method consists of titrating hydrogen sulfide in a gas sample directly with a standard solution of iodine.

(b) *Apparatus.* (See figure 1 to this section.) A 100- or 500-ml capacity Tutwiler burette, with two-way glass stopcock at bottom and three-way stopcock at top that connect either with inlet tubulature or glass-stoppered cylinder, 10 ml capacity, graduated in 0.1 ml subdivision; rubber tubing connecting burette with leveling bottle.

(c) *Reagents.* (1) Iodine stock solution, 0.1N. Weight 12.7 g iodine, and 20 to 25 g cp potassium iodide (KI) for each liter of solution. Dissolve KI in as little water as necessary; dissolve iodine in concentrated KI solution, make up to proper volume, and store in glass-stoppered brown glass bottle.

(2) Standard iodine solution, 1 ml = 0.001771 g I. Transfer 33.7 ml of above 0.1N stock solution into a 250 ml volumetric flask; add water to mark and mix well. Then, for 100 ml sample of gas, 1 ml of standard iodine solution is equivalent to 100 grains H₂S per cubic feet of gas.

(3) Rub into a thin paste about one teaspoonful of wheat starch with a little water; pour into about a pint of boiling

water; stir; let cool and decant off clear solution. Make fresh solution every few days.

(d) *Procedure.* (Refer to figure 1 to this section.) Fill leveling bulb with starch solution. Raise (L), open cock (G), open (F) to (A), and close (F) when solutions start to run out of gas inlet. Close (G). Purge gas sampling line and connect with (A). Lower (L) and open (F) and (G). When liquid level is several ml past the 100 ml mark, close (G) and (F), and disconnect sampling tube. Open (G) and bring starch solution to 100 ml mark by raising (L); then close (G). Open (F) momentarily, to bring gas in burette to atmospheric pressure, and close (F). Open (G), bring liquid level down to 10 ml mark by lowering (L). Close (G), clamp rubber tubing near (E) and disconnect it from burette. Rinse graduated cylinder with a standard iodine solution (0.00171 g I per ml); fill cylinder and record reading. Introduce successive small amounts of iodine through (F); shake well after each addition; continue until a faint permanent blue color is obtained. Record reading; subtract from previous reading, and call difference D.

(e) *Blank testing.* (Refer to figure 1 to this section.) With every fresh stock of starch solution perform a blank test as follows: Introduce fresh starch solution into burette up to 100 ml mark. Close (F) and (G). Lower (L) and open (G). When liquid level reaches the 10 ml mark, close (G). With air in burette, titrate as during a test and up to same end point. Call ml of iodine used C. Then,

Equation 1 to paragraph (e)

$$\text{Grains H}_2\text{S per 100 cubic feet of gas} = 100 (D-C)$$

(f) *Test sensitivity.* Greater sensitivity can be attained if a 500 ml capacity Tutwiler burette is used with a more dilute (0.001N) iodine solution.

Concentrations less than 1.0 grains per 100 cubic foot can be determined in this way. Usually, the starch-iodine end point is much less distinct, and a blank

determination of end point, with H₂S-free gas or air, is required.

BILLING CODE 6560-50-P

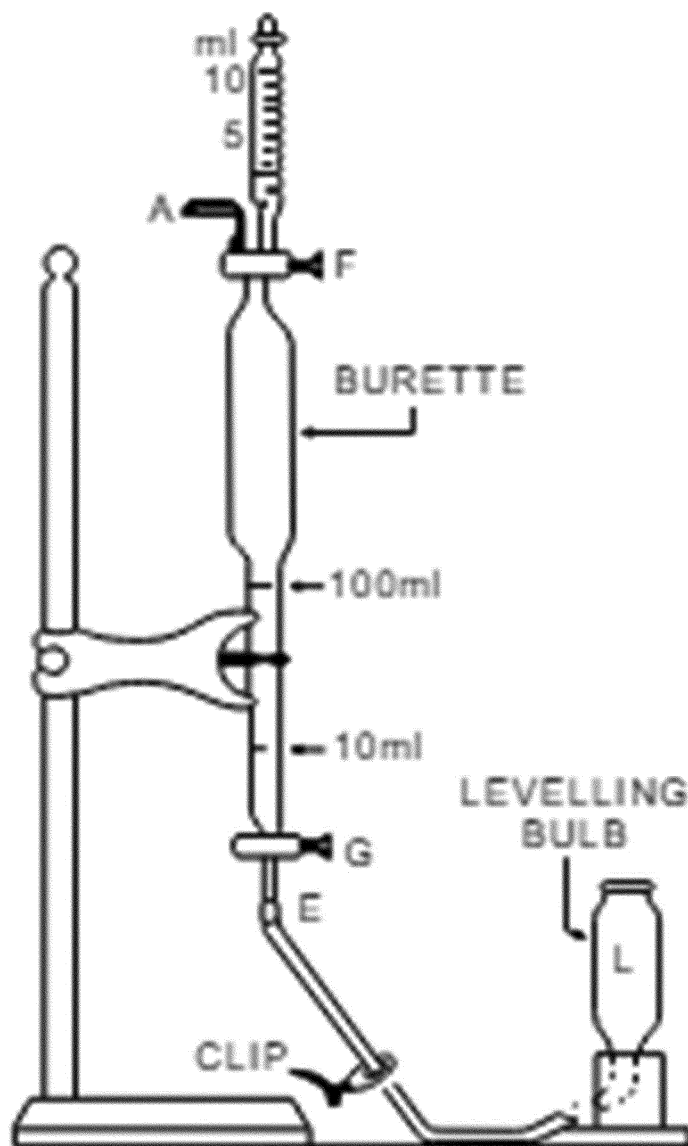

Figure 1 to § 60.5408b. Tutwiler burette (lettered items mentioned in text).

BILLING CODE 6560-50-C

§ 60.5410b How do I demonstrate initial compliance with the standards for each of my affected facilities?

You must determine initial compliance with the standards for each affected facility using the requirements of paragraphs (a) through (k) of this section. Except as otherwise provided in this section, the initial compliance period begins on the date specified in § 60.5370b and ends no later than 1 year after that date. The initial compliance period may be less than 1 full year.

(a) *Well completion standards for well affected facilities.* To achieve initial compliance with the GHG and VOC standards for each well completion operation conducted at your well affected facility as required by

§ 60.5375b, you must comply with paragraphs (a)(1) through (4) of this section.

(1) You must submit the notification required in § 60.5420b(a)(2).

(2) You must submit the initial annual report for your well affected facility as required in § 60.5420b(b)(1) and (2).

(3) You must maintain a log of records as specified in § 60.5420b(c)(1)(i) through (iv) and (vii), as applicable, for each well completion operation conducted. If you meet the exemption at § 60.5375b(g) for wells with a GOR less than 300 scf per stock barrel of oil produced, you do not have to maintain the records in § 60.5420b(c)(1)(i) through (iv) and must maintain the record in § 60.5420b(c)(1)(vi). If you meet the exemption at § 60.5375b(h) for a well modified in accordance with § 60.5365b(a)(1)(ii) (*i.e.*, an existing well is hydraulically refractured), you do not

need to maintain the records in § 60.5420b(c)(1)(i) through (iv) and must maintain the record in § 60.5420b(c)(1)(viii).

(4) For each well completion affected facility subject to both § 60.5375b(a)(1) and (2), as an alternative to retaining the records specified in § 60.5420b(c)(1)(i) through (iv), you may maintain records in accordance with § 60.5420b(c)(1)(v).

(b) *Gas well liquids unloading standards for well affected facility.* To demonstrate initial compliance with the GHG and VOC standards for each gas well liquids unloading operation conducted at your gas well affected facility as required by § 60.5376b, you must comply with paragraphs (b)(1) through (4) of this section, as applicable.

(1) You must submit the initial annual report for your well affected facility as required in § 60.5420b(b)(1) and (3).

(2) If you comply by using a liquids unloading technology or technique that does not vent to the atmosphere according to § 60.5376b(a)(1), you must maintain the records specified in § 60.5420b(c)(2)(i).

(3) If you comply by using a liquids unloading technology or technique that vents to the atmosphere according to § 60.5376b(a)(2), (b) and (c), you must comply with paragraphs (b)(3)(i) and (ii) of this section.

(i) Employ best management practices to minimize venting of methane and VOC emissions as specified in § 60.5376b(c) for each gas well liquids unloading operation.

(ii) Maintain the records specified in § 60.5420b(c)(2)(ii).

(4) If you comply by using § 60.5376b(g), you must comply with paragraphs (b)(4)(i) through (vii) of this section.

(i) Reduce methane and VOC emissions by 95.0 percent or greater and as demonstrated by the requirements of § 60.5413b.

(ii) Install a closed vent system that meets the requirements of § 60.5411b(a) and (c) to capture all emissions and route all emissions to a control device that meets the conditions specified in § 60.5412b.

(iii) Conduct an initial performance test as required in § 60.5413b within 180 days after the initial gas well liquids unloading operation, or install a control device tested under § 60.5413b(d) which meets the criteria in § 60.5413b(d)(11) and (e), and comply with the continuous compliance requirements of § 60.5415b(f).

(iv) You must conduct the initial inspections required in § 60.5416b(a) and (b).

(v) You must install and operate the continuous parameter monitoring systems in accordance with § 60.5417b(a) through (i), as applicable.

(vi) You must maintain the records specified in § 60.5420b(c)(2)(iii), (c)(8) and (c)(10) through (13), as applicable and submit the reports as required by § 60.5420b(b)(11) through (13), as applicable.

(c) *Associated gas well standards for well affected facility.* To demonstrate initial compliance with the GHG and VOC standards for each associated gas well as required by § 60.5377b, you must comply with paragraphs (c)(1) through (3) of this section.

(1) If you comply with the requirements of § 60.5377b(a), you must maintain the records specified in § 60.5420b(c)(3)(i), (ii), and (iv).

(2) For associated gas wells that comply with § 60.5377b(f) based on a demonstration and certification that it is

not feasible to comply with paragraph (a)(1), (2), (3), and (4) of this section due to technical reasons in accordance with paragraph § 60.5377b(g), you must comply with paragraphs (c)(2)(i) and (ii) of this section.

(i) Document the technical reasons why it is infeasible to route recovered associated gas into a gas gathering flow line or collection system to a sales line, use it as an onsite fuel source, use it for another useful purpose that a purchased fuel or raw material would serve, or re-inject it into the well or inject it into another well, and submit this documentation in the initial annual report.

(ii) Submit the certification as required by § 60.5377b(g).

(3) If you comply with § 60.5377b(d) or (f), you must comply with paragraphs (c)(3)(i) through (vi) of this section.

(i) Reduce methane and VOC emissions by 95.0 percent or greater and as demonstrated by the requirements of § 60.5413b.

(ii) Install a closed vent system that meets the requirements of § 60.5411b(a) and (c) to capture the associated gas and route the captured associated gas to a control device that meets the conditions specified in § 60.5412b.

(iii) Conduct an initial performance test as required in § 60.5413b within 180 days after initial startup or by May 7, 2024, whichever date is later, or install a control device tested under § 60.5413b(d) which meets the criteria in § 60.5413b(d)(11) and (e) and you must comply with the continuous compliance requirements of § 60.5415b(f).

(iv) Conduct the initial inspections required in § 60.5416b(a) and (b).

(v) Install and operate the continuous parameter monitoring systems in accordance with § 60.5417b(a) through (i), as applicable.

(vi) Maintain the records specified in § 60.5420b(c)(3)(iv) and (c)(8) and (c)(10) through (13), as applicable.

(4) You must submit the initial annual report for your associated gas well as required in § 60.5420b(b)(1) and (4) and (b)(11) through (13), as applicable.

(d) *Centrifugal compressor affected facility.* To demonstrate initial compliance with the GHG and VOC standards for your centrifugal compressor affected facility that uses a wet seal as required by § 60.5380b, you must comply with paragraphs (d)(1) through (5) and paragraphs (d)(7) and (8) of this section. To demonstrate initial compliance with the GHG and VOC alternative standards for your centrifugal compressor affected facility that is a self-contained wet seal centrifugal compressor or a centrifugal

compressor at the Alaska North Slope equipped with sour seal oil separator and capture system as allowed by § 60.5380b, you must comply with paragraphs (d)(6) through (8) of this section. To demonstrate initial compliance with the GHG and VOC alternative standards for your dry seal centrifugal compressor as required by § 60.5380b, you must comply with paragraphs (d)(6) through (8) of this section.

(1) You must reduce methane and VOC emissions by 95.0 percent or greater according to § 60.5380b(a)(1) and (2) and as demonstrated by the requirements of § 60.5413b, or you must route emissions to a process according to § 60.5380b(a)(3).

(2) If you use a control device to reduce emissions to comply with § 60.5380b(a)(1) and (2), you must equip the wet seal fluid degassing system with a cover that meets the requirements of § 60.5411b(b) that is connected through a closed vent system that meets the requirements of § 60.5411b(a) and (c) and is routed to a control device that meets the conditions specified in § 60.5412b. If you comply with § 60.5380b(a)(3) by routing the closed vent system to a process as an alternative to routing the closed vent system to a control device, you must equip the wet seal fluid degassing system with a cover that meets the requirements of § 60.5411b(b), and route captured vapors through a closed vent system that meets the requirements of § 60.5411b(a) and (c).

(3) If you use a control device to comply with § 60.5380b(a)(1) and (2), you must conduct an initial performance test as required in § 60.5413b within 180 days after initial startup or by May 7, 2024, whichever date is later, or install a control device tested under § 60.5413b(d) which meets the criteria in § 60.5413b(d)(11) and (e) and you must comply with the continuous compliance requirements of § 60.5415b(f).

(4) If you use a control device to comply with § 60.5380b(a)(1) and (2) or comply with § 60.5380b(a)(3) by routing to a process, you must conduct the initial inspections required in § 60.5416b(a) and (b).

(5) If you use a control device to comply with § 60.5380b(a)(1) and (2), you must install and operate the continuous parameter monitoring systems in accordance with § 60.5417b(a) through (i), as applicable.

(6) You must maintain the volumetric flow rates for your centrifugal compressors as specified in paragraphs (d)(6)(i) through (iii) of this section, as applicable. You must conduct your

initial annual volumetric measurement as required by § 60.5380b(a)(5).

(i) For your self-contained wet seal centrifugal compressors, you must maintain the volumetric flow rate at or below 3 scfm per seal.

(ii) For your centrifugal compressor on the Alaska North Slope equipped with sour seal oil separator and capture system, you must maintain the volumetric flow rate at or below 9 scfm per seal.

(iii) For your dry seal compressor, you must maintain the volumetric flow rate at or below 10 scfm per seal.

(7) You must submit the initial annual report for your centrifugal compressor affected facility as required in § 60.5420b(b)(1) and (5) and (b)(11) through (13), as applicable.

(8) You must maintain the records as specified in § 60.5420b(c)(4) and (c)(8) through (13), as applicable.

(e) *Reciprocating compressor affected facility.* To demonstrate initial compliance with the GHG and VOC standards for each reciprocating compressor affected facility as required by § 60.5385b, you must comply with paragraphs (e)(1) through (7) of this section.

(1) If you comply with § 60.5385b by maintaining volumetric flow rate at or below 2 scfm per cylinder (or a combined cylinder volumetric flow rate greater than the number of compression cylinders multiplied by 2 scfm) as required by § 60.5385b(a), you must maintain volumetric flow rate at or below 2 scfm and you must conduct your initial annual volumetric flow rate measurement as required by § 60.5385b(a)(1).

(2) If you comply with § 60.5385b by collecting the methane and VOC emissions from your reciprocating compressor rod packing using a rod packing emissions collection system as required by § 60.5385b(d)(1), you must equip the reciprocating compressor with a cover that meets the requirements of § 60.5411b(b), route emissions to a process through a closed vent system that meets the requirements of § 60.5411b(a) and (c), and you must conduct the initial inspections required in § 60.5416b(a) and (b).

(3) If you comply with § 60.5385b(d) by collecting the emissions from your rod packing emissions collection system by using a control device to reduce VOC and methane emissions by 95.0 percent as required by § 60.5385b(d)(2), you must equip the reciprocating compressor with a cover that meets the requirements of § 60.5411b(b), route emissions to a control device that meets the conditions specified in § 60.5412b through a closed vent system that meets

the requirements of § 60.5411b(a) and (c) and you must conduct the initial inspections required in § 60.5416b(a) and (b).

(4) If you comply with § 60.5385b(d)(2), you must conduct an initial performance test as required in § 60.5413b within 180 days after initial startup or by May 7, 2024, whichever date is later, or install a control device tested under § 60.5413b(d) which meets the criteria in § 60.5413b(d)(11) and (e) and you must comply with the continuous compliance requirements of § 60.5415b(f).

(5) If you comply with § 60.5385b(d)(2), you must install and operate the continuous parameter monitoring systems in accordance with § 60.5417b(a) through (i), as applicable.

(6) You must submit the initial annual report for your reciprocating compressor as required in § 60.5420b(b)(1), (6), and (11) through (13), as applicable.

(7) You must maintain the records as specified in § 60.5420b(c)(5) and (8) through (13) as applicable.

(f) *Process controller affected facility.* To demonstrate initial compliance with GHG and VOC emission standards for your process controller affected facility as required by § 60.5390b, you must comply with paragraphs (f)(1) through (5) of this section, as applicable. If you change compliance methods, you must perform the applicable compliance demonstrations of paragraphs (f)(1) through (3) of this section again for the new compliance method, note the change in compliance method in the annual report required by § 60.5420b(b)(7)(iv), and maintain the records required by paragraph (f)(5) of this section for the new compliance method.

(1) For process controller affected facilities complying with the requirements of § 60.5390b(a), you must demonstrate that your process controller affected facility does not emit any VOC or methane to the atmosphere by meeting the requirements of paragraphs (f)(1)(i) or (ii) of this section.

(i) If you comply by routing the emissions to a process, you must meet the requirements for closed vent systems specified in paragraph (f)(3) of this section.

(ii) If you comply by using a self-contained natural gas-driven process controller, you must conduct an initial no identifiable emissions inspection as required by § 60.5416b(b).

(2) For each process controller affected facility located at a site in Alaska that does not have access to electrical power, you must demonstrate initial compliance with § 60.5390b(b)(1) and (2) or with § 60.5390b(b)(3), instead

of complying with paragraph § 60.5390b(a), by meeting the requirements specified in (f)(2)(i) through (v) of this section for each process controller, as applicable.

(i) For each process controller in the process controller affected facility operating with a bleed rate of less than or equal to 6 scfh, you must maintain records in accordance with § 60.5420b(c)(6)(iii)(A) that demonstrate the process controller is designed and operated to achieve a bleed rate less than or equal to 6 scfh.

(ii) For each process controller in the process controller affected facility operating with a bleed rate greater than 6 scfh, you must maintain records that demonstrate that a controller with a higher bleed rate than 6 scfh is required based on a specific functional need for that controller as specified in § 60.5420b(c)(6)(iii)(B).

(iii) For each intermittent vent process controller in the process controller affected facility you must demonstrate that each intermittent vent controller does not emit to the atmosphere during idle periods by conducting initial monitoring in accordance with § 60.5390b(b)(2)(ii).

(iv) For each process controller affected facility that complies by reducing methane and VOC emissions from all controllers in the process controller affected facility by 95.0 percent in accordance with § 60.5390b(b)(3), you must comply with paragraphs (b)(2)(iv)(A) through (D) of this section.

(A) Reduce methane and VOC emissions by 95.0 percent or greater and as demonstrated by the requirements of § 60.5413b.

(B) Route all process controller affected facility emissions to a control device that meets the conditions specified in § 60.5412b through a closed vent system that meets the requirements specified in paragraph (f)(3) of this section.

(C) Conduct an initial performance test as required in § 60.5413b within 180 days after initial startup or by May 7, 2024, whichever date is later, or install a control device tested under § 60.5413b(d) which meets the criteria in § 60.5413b(d)(11) and (e) and you must comply with the continuous compliance requirements of § 60.5415b(f).

(D) Install and operate the continuous parameter monitoring systems in accordance with § 60.5417b(a) through (i), as applicable.

(3) For each closed vent system used to comply with § 60.5390b, you must meet the requirements specified in

paragraphs (f)(3)(i) and (ii) of this section.

(i) Install a closed vent system that meets the requirements of § 60.5411b(a) and (c).

(ii) Conduct the initial inspections of the closed vent system and bypasses, if applicable, as required in § 60.5416b(a) and (b).

(4) You must submit the initial annual report for your process controller affected facility as required in § 60.5420b(b)(1) and (7).

(5) You must maintain the records as specified in § 60.5420b(c)(6).

(g) *Pump affected facility.* To demonstrate initial compliance with the GHG and VOC standards for your pump affected facility as required by § 60.5393b, you must comply with paragraphs (g)(1) through (4) of this section, as applicable. If you change compliance methods, you must perform the applicable compliance demonstrations of paragraphs (g)(1) and (2) of this section again for the new compliance method, note the change in compliance method in the annual report required by § 60.5420b(b)(10)(v)(C), and maintain the records required by paragraph (g)(4) of this section for the new compliance method.

(1) For pump affected facilities complying with the requirements of § 60.5393b(a) or (b)(2) by routing emissions to a process, you must meet the requirements specified in paragraphs (g)(ii) and (iv) of this section. For pump affected facilities complying with the requirements of § 60.5393b(b)(3), you must meet the requirements specified in paragraphs (g)(1)(i) through (v) of this section.

(i) Reduce methane and VOC emissions by 95.0 percent or greater and as demonstrated by the requirements of § 60.5413b.

(ii) Install a closed vent system that meets the requirements of § 60.5411b(a) and (c) to capture all emissions from all pumps in the pump affected facility and route all emissions to a process or control device that meets the conditions specified in § 60.5412b.

(iii) Conduct an initial performance test as required in § 60.5413b within 180 days after initial startup or by May 7, 2024, whichever date is later, or install a control device tested under § 60.5413b(d) which meets the criteria in § 60.5413b(d)(11) and (e) and you must comply with the continuous compliance requirements of § 60.5415b(f).

(iv) Conduct the initial inspections of the closed vent system and bypasses, if applicable, as required in § 60.5416b(a) and (b).

(v) Install and operate the continuous parameter monitoring systems in accordance with § 60.5417b(a) through (i), as applicable.

(2) Submit the certifications specified in paragraphs (g)(2)(i) through (iii) of this section, as applicable.

(i) The certification required by § 60.5393b(b)(3) that there is no vapor recovery unit on site and that there is a control device on site, but it does not achieve a 95.0 percent emissions reduction.

(ii) The certification required by § 60.5393b(b)(4) that there is no control device or process available on site.

(iii) The certification required by § 60.5393b(b)(5)(i) that it is technically infeasible to capture and route the pump affected facility emissions to a process or an existing control device.

(3) You must submit the initial annual report for your pump affected facility as specified in § 60.5420b(b)(1), (10), and (b)(11) through (13), as applicable.

(4) You must maintain the records for your pump affected facility as specified in § 60.5420b(c)(8) and (c)(10) through (13), as applicable, and (c)(15).

(h) *Process unit equipment affected facility.* To achieve initial compliance with the GHG and VOC standards for process unit equipment affected facilities as required by § 60.5400b, you must comply with paragraphs (h)(1) through (4) and (h)(11) through (15) of this section, unless you meet and comply with the exception in § 60.5402b(b), (e), or (f) or meet the exemption in § 60.5402b(c). If you comply with the GHG and VOC standards for process unit equipment affected facilities using the alternative standards in § 60.5401b, you must comply with paragraphs (h)(5) through (15) of this section, unless you meet the exemption in § 60.5402b(b) or (c) or the exception in § 60.5402b(e) or (f).

(1) You must conduct monitoring for each pump in light liquid service, pressure relief device in gas/vapor service, valve in gas/vapor or light liquid service and connector in gas/vapor or light liquid service as required by § 60.5400b(b).

(2) You must conduct monitoring as required by § 60.5400b(c) for each pump in light liquid service.

(3) You must conduct monitoring as required by § 60.5400b(d) for each pressure relief device in gas/vapor service.

(4) You must comply with the equipment requirements for each open-ended valve or line as required by § 60.5400b(e).

(5) You must conduct monitoring for each pump in light liquid service as required by § 60.5401b(b).

(6) You must conduct monitoring for each pressure relief device in gas/vapor service as required by § 60.5401b(c).

(7) You must comply with the equipment requirements for each open-ended valve or line as required by § 60.5401b(d).

(8) You must conduct monitoring for each valve in gas/vapor or light liquid service as required by § 60.5401b(f).

(9) You must conduct monitoring for each pump, valve, and connector in heavy liquid service and each pressure relief device in light liquid or heavy liquid service as required by § 60.5401b(g).

(10) You must conduct monitoring for each connector in gas/vapor or light liquid service as required by § 60.5401b(h).

(11) For each pump equipped with a dual mechanical seal system that degasses the barrier fluid reservoir to a process or a control device, each pump which captures and transports leakage from the seal or seals to a process or a control device, or each pressure relief device which captures and transports leakage through the pressure relief device to a process or a control device, you must meet the requirements of paragraph (h)(11)(i) through (vi) of this section.

(i) Reduce methane and VOC emissions by 95.0 percent or greater and as demonstrated by the requirements of § 60.5413b or route to a process.

(ii) Install a closed vent system that meets the requirements of § 60.5411b(a) and (c) to capture all emissions from each pump equipped with a dual mechanical seal system that degasses the barrier fluid reservoir, each pump which captures and transports leakage from the seal or seals, or each pressure relief device which captures and transports leakage through the pressure relief device and route all emissions to a process or to a control device that meets the conditions specified in § 60.5412b.

(iii) If routing to a control device, conduct an initial performance test as required in § 60.5413b within 180 days after initial startup or by May 7, 2024, whichever date is later, or install a control device tested under § 60.5413b(d) which meets the criteria in § 60.5413b(d)(11) and (e), and you must comply with the continuous compliance requirements of § 60.5415b(f).

(iv) Conduct the initial inspections of the closed vent system and bypasses, if applicable, as required in § 60.5416b(a) and (b).

(v) Install and operate the continuous parameter monitoring systems in

accordance with § 60.5417b(a) through (i), as applicable.

(vi) Maintain the records as required by § 60.5420b(c)(8) and (c)(10) through (c)(13), as applicable and submit the reports as required by § 60.5420b(b)(11) through (13), as applicable.

(12) You must tag and repair each identified leak as required in § 60.5400b(h) or § 60.5400b(i), as applicable.

(13) You must submit the notice required by § 60.5420b(a)(1).

(14) You must submit the initial semiannual report and subsequent semiannual report as required by § 60.5422b.

(15) You must maintain the records specified by § 60.5421b.

(i) *Sweetening unit affected facility.* To achieve initial compliance with the SO₂ standard for your sweetening unit affected facility as required by § 60.5405b, you must comply with paragraphs (i)(1) through (14) of this section.

(1) You must conduct an initial performance test as required by § 60.8 and according to the requirements of § 60.5406b.

(2) You must determine the minimum required initial reduction efficiency of SO₂ emissions (Z_i) as required by § 60.5406b(b).

(3) You must determine the emission reduction efficiency (R) achieved by your sulfur reduction technology using the procedures in § 60.5406b(c)(1) through (4).

(4) You must demonstrate compliance with the standard as required by § 60.5405b(a) by comparing the minimum required SO₂ emission reduction efficiency (Z_i) to the emission reduction efficiency achieved by the sulfur recovery technology (R), where R must be greater than or equal to Z_i .

(5) You must install, calibrate, maintain, and operate monitoring devices or perform measurements to determine the accumulation of sulfur product, the H₂S concentration, the average acid gas flow rate, and the sulfur feed rate in accordance with § 60.5407b(a).

(6) You must determine the required SO₂ emissions reduction efficiency each 24-hour period in accordance with § 60.5407b(a), (d), and (e), as applicable.

(7) You must install, calibrate, maintain, and operate monitoring devices and continuous emission monitors in accordance with § 60.5407b(b), (f), and (g), if you use an oxidation control system or a reduction control system followed by an incineration device.

(8) You must continuously operate the incineration device if you use an

oxidation control system, or a reduction control system followed by an incineration device.

(9) You must install, calibrate, maintain, and operate a continuous monitoring system to measure the emission rate of reduced sulfur compounds in accordance with § 60.5407b(c), (f), and (g), if you use a reduction control system not followed by an incineration device.

(10) You must submit the notification required by § 60.5420b(a)(1).

(11) You must submit the initial annual report required by § 60.5423b(b).

(12) You must submit the performance test report in accordance with the requirements of § 60.5420b(b)(12).

(13) You must submit the annual excess emissions reports required by § 60.5423b(d), if applicable.

(14) You must maintain the records required by § 60.5423b(a), (e) and (f), as applicable.

(j) *Storage vessel affected facility.* To achieve initial compliance with the GHG and VOC standards for each storage vessel affected facility as required by § 60.5395b, you must comply with paragraphs (j)(1) through (9) of this section. To achieve initial compliance with the GHG and VOC standards for each storage vessel affected facility that complies by using a floating roof in accordance with § 60.5395b(b)(2), you must comply with paragraphs (j)(1) and (10) of this section.

(1) You must determine the potential for methane and VOC emissions as specified in § 60.5365b(e)(2).

(2) You must reduce methane and VOC emissions by 95.0 percent or greater according to § 60.5395b(a) and as demonstrated by the requirements of § 60.5413b or route to a process.

(3) If you use a control device to reduce emissions, you must equip each storage vessel in the storage vessel affected facility with a cover that meets the requirements of § 60.5411b(b), install a closed vent system that meets the requirements of § 60.5411b(a) and (c) to capture all emissions from the storage vessel affected facility, and route all emissions to a control device that meets the conditions specified in § 60.5412b. If you route emissions to a process, you must equip each storage vessel in the storage vessel affected facility with a cover that meets the requirements of § 60.5411b(b), install a closed vent system that meets the requirements of § 60.5411b(a) and (c) to capture all emissions from the storage vessel affected facility, and route all emissions to a process.

(4) If you use a control device to reduce emissions, you must conduct an

initial performance test as required in § 60.5413b within 180 days after initial startup or within 180 days of May 7, 2024, whichever date is later, or install a control device tested under § 60.5413b(d) which meets the criteria in § 60.5413b(d)(11) and (e), and you must comply with the continuous compliance requirements of § 60.5415b(f).

(5) You must conduct the initial inspections of the closed vent system and bypasses, if applicable, as required in § 60.5416b(a) and (b).

(6) You must install and operate the continuous parameter monitoring systems in accordance with § 60.5417b(a) through (i), as applicable.

(7) You must maintain the records as required by § 60.5420b(c)(8) through (13), as applicable and submit the reports as required by § 60.5420b(b)(11) through (13), as applicable.

(8) You must submit the initial annual report for your storage vessel affected facility required by § 60.5420b(b)(1) and (8).

(9) You must maintain the records required for your storage vessel affected facility, as specified in § 60.5420b(c)(7) for each storage vessel affected facility.

(10) For each storage vessel affected facility that complies by using a floating roof, you must meet the requirements of § 60.112b(a)(1) or (2) and the relevant monitoring, inspection, recordkeeping, and reporting requirements in subpart Kb of this part. You must submit a statement that you are complying with § 60.112b(d)(a)(1) or (2) in accordance with § 60.5395b(b)(2) with the initial annual report specified in § 60.5420b(b)(1) and (8).

(k) *Fugitive emission components affected facility.* To achieve initial compliance with the GHG and VOC standards for fugitive emissions components affected facilities as required by § 60.5397b, you must comply with paragraphs (k)(1) through (5) of this section.

(1) You must develop a fugitive emissions monitoring plan as required in § 60.5397b(b), (c), and (d).

(2) You must conduct an initial monitoring survey as required in § 60.5397b(e) and (f).

(3) You must repair each identified source of fugitive emissions for each affected facility as required in § 60.5397b(h).

(4) You must submit the initial annual report for each fugitive emissions components affected facility as required in § 60.5420b(b)(1) and (9).

(5) You must maintain the records specified in § 60.5420b(c)(14).

§ 60.5411b What additional requirements must I meet to determine initial compliance for my covers and closed vent systems?

For each cover or closed vent system at your well, centrifugal compressor, reciprocating compressor, process controller, pump, storage vessel, and process unit equipment affected facilities, you must comply with the applicable requirements of paragraphs (a) through (c) of this section.

(a) *Closed vent system requirements.*

(1) Reciprocating compressor rod packing, process controllers, and pumps. You must design the closed vent system to capture and route all gases, vapors, and fumes to a process.

(2) Associated gas wells, centrifugal compressors, process controllers in Alaska, pumps complying with § 60.5393b(1), storage vessels, and process unit equipment. You must design the closed vent system to capture and route all gases, vapors, and fumes to a process or a control device that meets the requirements specified in § 60.5412b(a) through (d) of this section. For pumps complying with § 60.5393b(3), you must design the closed vent system to capture and route all gases, vapors, and fumes to a control device that meets the requirements specified in § 60.5412b(a) through (d) of this section.

(3) You must design and operate the closed vent system with no identifiable emissions as demonstrated by § 60.5416b(a) and (b).

(4) Bypass devices. You must meet the requirements specified in paragraphs (a)(4)(i) and (ii) of this section if the closed vent system contains one or more bypass devices that could be used to divert all or a portion of the gases, vapors, or fumes from entering the control device or being routed to a process.

(i) Except as provided in paragraph (a)(4)(ii) of this section, you must comply with either paragraph (a)(4)(i)(A) or (B) of this section for each bypass device.

(A) You must properly install, calibrate, maintain, and operate a flow indicator at the inlet to the bypass device. The flow indicator must be capable of taking periodic readings as specified in § 60.5416b(a)(4)(i) and sound an alarm, or initiate notification via remote alarm to the nearest field office, when the bypass device is open such that the stream is being, or could be, diverted away from the control device or process, and sent to the atmosphere. You must maintain records of each time the alarm is activated according to § 60.5420b(c)(10).

(B) You must secure the bypass device valve installed at the inlet to the bypass

device in the non-diverting position using a car-seal or a lock-and-key type configuration.

(ii) Low leg drains, high point bleeds, analyzer vents, open-ended valves or lines, and safety devices are not subject to the requirements of paragraph (a)(4)(i) of this section.

(b) *Cover requirements for storage vessels and centrifugal compressors, and reciprocating compressors.* (1) The cover and all openings on the cover (e.g., access hatches, sampling ports, pressure relief devices and gauge wells) shall form a continuous impermeable barrier over the entire surface area of the liquid in the storage vessel or centrifugal compressor wet seal fluid degassing system, or reciprocating compressor rod packing emissions collection system.

(2) Each cover opening shall be secured in a closed, sealed position (e.g., covered by a gasketed lid or cap) whenever material is in the unit on which the cover is installed except during those times when it is necessary to use an opening as follows:

(i) To add material to, or remove material from the unit (this includes openings necessary to equalize or balance the internal pressure of the unit following changes in the level of the material in the unit);

(ii) To inspect or sample the material in the unit;

(iii) To inspect, maintain, repair, or replace equipment located inside the unit; or

(iv) To vent liquids, gases, or fumes from the unit through a closed vent system designed and operated in accordance with the requirements of paragraph (a) of this section to a control device or to a process.

(3) Each storage vessel thief hatch shall be equipped, maintained and operated with a weighted mechanism or equivalent, to ensure that the lid remains properly seated and sealed under normal operating conditions, including such times when working, standing/breathing, and flash emissions may be generated. You must select gasket material for the hatch based on composition of the fluid in the storage vessel and weather conditions.

(4) You must design and operate the cover with no identifiable emissions as demonstrated by § 60.5416b(a) and (b), except when operated as provided in paragraphs (b)(2)(i) through (iii) of this section.

(c) *Design requirements.* (1) You must conduct an assessment that the closed vent system is of sufficient design and capacity to ensure that all gases, vapors, and fumes from the affected facility are routed to the control device or process

and that the control device or process is of sufficient design and capacity to accommodate all emissions from the affected facility. The assessment must be certified by a qualified professional engineer or an in-house engineer with expertise on the design and operation of the closed vent system in accordance with paragraphs (c)(1)(i) and (ii) of this section.

(i) You must provide the following certification, signed and dated by a qualified professional engineer or an in-house engineer: "I certify that the closed vent system design and capacity assessment was prepared under my direction or supervision. I further certify that the closed vent system design and capacity assessment was conducted, and this report was prepared pursuant to the requirements of subpart OOOOb of this part. Based on my professional knowledge and experience, and inquiry of personnel involved in the assessment, the certification submitted herein is true, accurate, and complete."

(ii) The assessment shall be prepared under the direction or supervision of a qualified professional engineer or an in-house engineer who signs the certification in paragraph (c)(1)(i) of this section.

§ 60.5412b What additional requirements must I meet for determining initial compliance of my control devices?

You must meet the requirements of paragraphs (a) and (b) of this section for each control device used to comply with the emissions standards for your well, centrifugal compressor, reciprocating compressor, storage vessel, process controller, pump, or process unit equipment affected facility. If you use a carbon adsorption system as a control device to meet the requirements of paragraph (a)(2) of this section, you also must meet the requirements in paragraph (c) of this section.

(a) Each control device used to meet the emissions reduction standard in § 60.5377b(f) for your associated gas well at a well affected facility; § 60.5376b(g) for your well affected facility gas well that unloads liquids; § 60.5380b(a)(1) for your centrifugal compressor affected facility; § 60.5385b(d)(2) for your reciprocating compressor affected facility; § 60.5395b(a)(2) for your storage vessel affected facility; § 60.5390b(b)(3) for your process controller affected facility in Alaska; § 60.5393b(b)(1) for your pumps affected facility; or either § 60.5400b(f) or § 60.5401b(e) for your process equipment affected facility must be installed according to paragraphs (a)(1) through (3) of this section. As an alternative to paragraphs (a)(1) through

(a)(3) of this section, you may install a control device model tested under § 60.5413b(d), which meets the criteria in § 60.5413b(d)(11) and which meets the initial and continuous compliance requirements in § 60.5413b(e).

(1) Each enclosed combustion device (e.g., thermal vapor incinerator, catalytic vapor incinerator, boiler, or process heater) must be designed and operated in accordance with paragraph (a)(1)(i) of this section, meet one of the operating limits specified in paragraphs (a)(1)(ii) through (v) of this section, and except for boilers and process heaters meeting the requirements of paragraph (a)(1)(iii) of this section and catalytic vapor incinerators meeting the requirements of paragraph (a)(1)(v) of this section, meet the operating limits specified in paragraphs (a)(1)(vi) through (ix) of this section. Alternatively, the enclosed combustion device must meet the requirements specified in paragraph (d) of this section.

(i) You must reduce the mass content of methane and VOC in the gases vented to the device by 95.0 percent by weight or greater or reduce the concentration of total organic compounds (TOC) in the exhaust gases at the outlet to the device to a level equal to or less than 275 ppmv as propane on a wet basis corrected to 3 percent oxygen as determined in accordance with the requirements of § 60.5413b(b), with the exceptions noted in § 60.5413b(a).

(ii) For an enclosed combustion device for which you demonstrate during the performance test conducted under § 60.5413b(b) that combustion zone temperature is an indicator of destruction efficiency, you must operate at or above the minimum temperature established during the most recent performance test. During the performance test conducted under § 60.5413b(b), you must continuously record the temperature of the combustion zone and average the temperature for each test run. The established minimum temperature limit is the average of the test run averages.

(iii) For an enclosed combustion device which is a boiler or process heater, you must introduce the vent stream into the flame zone of the boiler or process heater and introduce the vent stream with the primary fuel or use the vent stream as the primary fuel.

(iv) For an enclosed combustion device other than those meeting the operating limits in paragraphs (a)(1)(ii), (iii), and (v) of this section, if the enclosed combustion device is unassisted or pressure-assisted, you must maintain the net heating value (NHV) of the gas sent to the enclosed combustion device at or above the

applicable limits specified in paragraphs (a)(1)(iv)(A) and (B) of this section. If the enclosed combustion device is steam-assisted or air-assisted, you must meet the applicable limits specified in paragraphs (a)(1)(iv)(C) and (D) of this section, as appropriate.

(A) For enclosed combustion devices that do not use assist gas or pressure-assisted burner tips to promote mixing at the burner tip, 200 British thermal units (Btu) per standard cubic feet (Btu/scf).

(B) For enclosed combustion devices that use pressure-assisted burner tips to promote mixing at the burner tip, 800 Btu/scf.

(C) For steam-assisted and air-assisted enclosed combustion devices, maintain the combustion zone NHV (NHV_{cz}) at or above 270 Btu/scf.

(D) For enclosed combustion devices with perimeter assist air, maintain the NHV dilution parameter (NHV_{dil}) at or above 22 British thermal units per square foot (Btu/sqft). If the only assist air provided to the enclosed combustion control device is perimeter assist air intentionally entrained in lower and/or upper steam at the burner tip and the effective diameter is 9 inches or greater, you are only required to comply with the NHV_{cz} limit specified in paragraph (a)(1)(iv)(C) of this section.

(v) For an enclosed combustion device which is a catalytic vapor incinerator, you must operate the catalytic vapor incinerator at or above the minimum temperature of the catalyst bed inlet and at or above the minimum temperature differential between the catalyst bed inlet and the catalyst bed outlet established in accordance with § 60.5417b(f) and as determined in your performance test conducted in accordance with § 60.5413b(b).

(vi) Unless you have an enclosed combustion device with pressure-assisted burner tips to promote mixing at the burner tip, you must operate each enclosed combustion device at or below the maximum inlet gas flow rate established in accordance with § 60.5417b(f) and as determined in your performance test conducted in accordance with § 60.5413b(b).

(vii) You must operate the combustion control device at or above the minimum inlet gas flow rate established in accordance with § 60.5417b(f).

(viii) You must install and operate a continuous burning pilot or combustion flame. An alert must be sent to the nearest control room whenever the pilot or combustion flame is unlit.

(ix) You must operate the enclosed combustion device with no visible emissions, except for periods not to

exceed a total of 1 minute during any 15-minute period. A visible emissions test using section 11 of Method 22 of appendix A-7 to this part must be performed at least once every calendar month, separated by at least 15 days between each test. The observation period shall be 15 minutes or once the amount of time visible emissions is present has exceeded 1 minute, whichever time period is less. Alternatively, you may conduct visible emissions monitoring according to § 60.5417b(h). Devices failing the visible emissions test must follow manufacturer's repair instructions, if available, or best combustion engineering practice as outlined in the unit inspection and maintenance plan, to return the unit to compliant operation. All inspection, repair, and maintenance activities for each unit must be recorded in a maintenance and repair log and must be available for inspection. Following return to operation from maintenance or repair activity, each device must pass a Method 22 of appendix A-7 to this part visual observation as described in this paragraph or be monitored according to § 60.5417b(h).

(2) Each vapor recovery device (e.g., carbon adsorption system or condenser) or other non-destructive control device must be designed and operated to reduce the mass content of methane and VOC in the gases vented to the device by 95.0 percent by weight or greater as determined in accordance with the requirements of § 60.5413b(b). As an alternative to the performance testing requirements of § 60.5413b(b), you may demonstrate initial compliance by conducting a design analysis for vapor recovery devices according to the requirements of § 60.5413b(c). For a condenser, you also must calculate the daily average condenser outlet temperature in accordance with § 60.5417b(e), and you must determine the condenser efficiency for the current operating day using the daily average condenser outlet temperature and the condenser performance curve established in accordance with § 60.5417b(f)(2). You must determine the average TOC emission reduction in accordance with § 60.5415b(f)(1)(ix)(D). For a carbon adsorption system, you also must comply with paragraph (c) of this section.

(3) Each flare must be designed and operated according to the requirements specified in paragraphs (a)(3)(i) through (viii) of this section, as applicable. Alternatively, flares must meet the requirements specified in paragraph (d) of this section.

(j) For unassisted flares, you must maintain the NHV of the vent gas sent to the flare at or above 200 Btu/scf.

(ii) For flares that use pressure-assisted burner tips to promote mixing at the burner tip, you must maintain the NHV of the vent gas sent to the flare at or above 800 Btu/scf.

(iii) For steam-assisted and air-assisted flares, you must maintain the NHV_{cz} at or above 270 Btu/scf.

(iv) For flares with perimeter assist air, you must maintain the NHV_{dil} at or above 22 Btu/sqft. If the only assist air provided to the flare is perimeter assist air intentionally entrained in lower and/or upper steam at the flare tip and the effective diameter is 9 inches or greater, you are not required to comply with the NHV_{dil} limit.

(v) For flares other than pressure-assisted flares, you must demonstrate compliance with the flare tip velocity limits in § 60.18(b) according to § 60.5417b(d)(8)(iv). The maximum flare tip velocity limits do not apply for pressure-assisted flares.

(vi) You must operate the flare at or above the minimum inlet gas flow rate. The minimum inlet gas flow rate is established based on manufacturer recommendations.

(vii) You must operate the flare with no visible emissions, except for periods not to exceed a total of 1 minute during any 15-minute period. You must conduct the compliance determination with the visible emission limits using Method 22 of appendix A-7 to this part, or you must monitor the flare according to § 60.5417b(h).

(viii) You must install and operate a continuous burning pilot or combustion flame. An alert must be sent to the nearest control room whenever the pilot or combustion flame is unlit.

(b) You must operate each control device installed on your well, centrifugal compressor, reciprocating compressor, storage vessel, process controller, pump, or process unit equipment affected facility in accordance with the requirements specified in paragraphs (b)(1) and (2) of this section.

(1) You must operate each control device used to comply with this subpart at all times when gases, vapors, and fumes are vented from the affected facility through the closed vent system to the control device. You may vent more than one affected facility to a control device used to comply with this subpart.

(2) For each control device monitored in accordance with the requirements of § 60.5417b(a) through (i), you must demonstrate compliance according to

the requirements of § 60.5415b(f), as applicable.

(c) For each carbon adsorption system used as a control device to meet the requirements of paragraph (a)(2) of this section, you must comply with the requirements of paragraph (c)(1) of this section. If the carbon adsorption system is a regenerative-type carbon adsorption system, you also must comply with the requirements of paragraph (c)(2) of this section.

(1) You must manage the carbon in accordance with the requirements specified in paragraphs (c)(1)(i) and (ii) of this section.

(i) Following the initial startup of the control device, you must replace all carbon in the carbon adsorption system with fresh carbon on a regular, predetermined time interval that is no longer than the carbon service life established according to § 60.5413b(c)(2) or (3). You must maintain records identifying the schedule for replacement and records of each carbon replacement as required in § 60.5420b(c)(10) and (12).

(ii) You must either regenerate, reactivate, or burn the spent carbon removed from the carbon adsorption system in one of the units specified in paragraphs (c)(1)(ii)(A) through (F) of this section.

(A) Regenerate or reactivate the spent carbon in a unit for which you have been issued a final permit under 40 CFR part 270 that implements the requirements of 40 CFR part 264, subpart X.

(B) Regenerate or reactivate the spent carbon in a unit equipped with an operating organic air emissions control in accordance with an emissions standard for VOC under another subpart in 40 CFR part 63 or this part.

(C) Burn the spent carbon in a hazardous waste incinerator for which the owner or operator complies with the requirements of 40 CFR part 63, subpart EEE, and has submitted a Notification of Compliance under 40 CFR 63.1207(j).

(D) Burn the spent carbon in a hazardous waste boiler or industrial furnace for which the owner or operator complies with the requirements of 40 CFR part 63, subpart EEE, and has submitted a Notification of Compliance under 40 CFR 63.1207(j).

(E) Burn the spent carbon in an industrial furnace for which you have been issued a final permit under 40 CFR part 270 that implements the requirements of 40 CFR part 266, subpart H.

(F) Burn the spent carbon in an industrial furnace that you have designed and operated in accordance

with the interim status requirements of 40 CFR part 266, subpart H.

(2) You must comply with the requirements of paragraph (c)(2)(i) through (iii) of this section for each regenerative-type carbon adsorption system.

(i) You must measure and record the average total regeneration stream mass flow or volumetric flow during each carbon bed regeneration cycle to demonstrate compliance with the total regeneration stream flow established in accordance with § 60.5413b(c)(2).

(ii) You must check the mechanical connections for leakage at least every month, and you must perform a visual inspection at least every 3 months of all components of the flow continuous parameter monitoring system for physical and operational integrity and all electrical connections for oxidation and galvanic corrosion, if your continuous parameter monitoring system is not equipped with a redundant flow sensor.

(iii) You must measure and record the average carbon bed temperature for the duration of the carbon bed steaming cycle and measure the actual carbon bed temperature after regeneration and within 15 minutes of completing the cooling cycle. You must maintain the average carbon bed temperature above the temperature limit in established accordance with § 60.5413b(c)(2) during the carbon bed steaming cycle and below the carbon bed temperature established in accordance with § 60.5413b(c)(2) after the regeneration cycle.

(d) To demonstrate that a flare or enclosed combustion device reduces methane and VOC in the gases vented to the device by 95.0 percent by weight or greater, as outlined in § 60.8(b), you may submit a request for an alternative test method. At a minimum, the request must follow the requirements outlined in paragraphs (d)(1) through (5) of this section.

(1) The alternative method must be capable of demonstrating continuous compliance with a combustion efficiency of 95.0 percent or greater or it must be capable of demonstrating continuous compliance with the following metrics:

(i) NHV_{cz} of 270 Btu/scf or greater.

(ii) NHV_{dil} of 22 Btu/sqft or greater, if the alternative test method will be used for enclosed combustion devices or flares with perimeter assist air.

(2) The alternative method must be validated according to Method 301 in appendix A of 40 CFR part 63 for each type of control device covered by the alternative test method (e.g., air-assisted flare, unassisted enclosed combustion

device) or the alternative test method must contain performance-based procedures and indicators to ensure self-validation.

(3) At a minimum the alternative test method must provide a reading for each successive 15-minute period.

(4) The alternative test method must be capable of documenting periods when the enclosed combustion device or flare operates with visible emissions. If the alternative test method cannot identify periods of visible emissions, you must conduct the inspections required by § 5417b(d)(8)(v).

(5) If the alternative test method demonstrates compliance with the metrics specified in paragraphs (d)(1)(i) and (ii) of this section instead of demonstrating continuous compliance with 95.0 percent or greater combustion efficiency, you must still install the pilot or combustion flame monitoring system required by § 60.5417b(d)(8)(i). If the alternative test method demonstrates continuous compliance with a combustion efficiency of 95.0 percent or greater, the requirement in § 60.5417b(d)(8)(i) no longer applies.

§ 60.5413b What are the performance testing procedures for control devices?

This section applies to the performance testing of control devices used to demonstrate compliance with the emissions standards for your well, centrifugal compressor, reciprocating compressor, storage vessel, process controller, pump affected facilities complying with § 60.5393b(b)(1), or process unit equipment affected facility. You must demonstrate that a control device achieves the performance requirements of § 60.5412b(a)(1) or (2) using the performance test methods and procedures specified in this section. For condensers and carbon adsorbers, you may use a design analysis as specified in paragraph (c) of this section in lieu of complying with paragraph (b) of this section. In addition, this section contains the requirements for enclosed combustion device performance tests conducted by the manufacturer applicable to well, centrifugal compressor, reciprocating compressor, storage vessel, process controller, pump affected facilities complying with

§ 60.5393b(b)(1), or process unit equipment affected facilities.

(a) *Performance test exemptions.* You are exempt from the requirements to conduct initial and periodic performance tests and design analyses if you use any of the control devices described in paragraphs (a)(1) through (6) of this section. You are exempt from the requirements to conduct an initial performance test if you use a control device described in paragraph (a)(7) of this section.

(1) A flare that is designed and operated in accordance with the requirements in § 60.5412b(a)(3). You must conduct the compliance determination using Method 22 of appendix A-7 to this part to determine visible emissions or monitor the flare according to § 60.5417b(h). The net heating value of the vent gas must be determined according to § 60.5417b(d)(8)(ii).

(2) A boiler or process heater with a design heat input capacity of 44 megawatts or greater.

(3) A boiler or process heater into which the vent stream is introduced with the primary fuel or is used as the primary fuel.

(4) A boiler or process heater burning hazardous waste for which you have been issued a final permit under 40 CFR part 270 and comply with the requirements of 40 CFR part 266, subpart H; you have certified compliance with the interim status requirements of 40 CFR part 266, subpart H; you have submitted a Notification of Compliance under 40 CFR 63.1207(j) and comply with the requirements of 40 CFR part 63, subpart EEE; or you comply with 40 CFR part 63, subpart EEE and will submit a Notification of Compliance under 40 CFR 63.1207(j) by the date specified in § 60.5420b(b)(12) for submitting the initial performance test report.

(5) A hazardous waste incinerator for which you have submitted a Notification of Compliance under 40 CFR 63.1207(j), or for which you will submit a Notification of Compliance under 40 CFR 63.1207(j) by the date specified in § 60.5420b(b)(12) for submitting the initial performance test report, and you comply with the

requirements of 40 CFR part 63, subpart EEE.

(6) A control device for which performance test is waived in accordance with § 60.8(b).

(7) A control device whose model can be demonstrated to meet the performance requirements of § 60.5412b(a)(1)(i) through a performance test conducted by the manufacturer, as specified in paragraph (d) of this section.

(b) *Test methods and procedures.* You must use the test methods and procedures specified in paragraphs (b)(1) through (4) of this section, as applicable, for each performance test conducted to demonstrate that a control device meets the requirements of § 60.5412b(a)(1) or (2). You must conduct the initial and periodic performance tests according to the schedule specified in paragraph (b)(5) of this section. Each performance test must consist of a minimum of 3 test runs. Each run must be at least 1 hour long.

(1) You must use Method 1 or 1A of appendix A-1 to this part, as appropriate, to select the sampling sites. Any references to particulate mentioned in Methods 1 and 1A do not apply to this section.

(i) Sampling sites must be located at the inlet of the first control device and at the outlet of the final control device to determine compliance with a control device percent reduction requirement.

(ii) The sampling site must be located at the outlet of the combustion device to determine compliance with a TOC exhaust gas concentration limit.

(2) You must determine the gas volumetric flow rate using Method 2, 2A, 2C, or 2D of appendix A-2 to this part, as appropriate.

(3) To determine compliance with the control device percent reduction performance requirement in § 60.5412b(a)(1)(i) or (a)(2), you must use Method 25A of appendix A-7 to this part. You must use Method 4 of appendix A-3 to this part to convert the Method 25A results to a dry basis. You must use the procedures in paragraphs (b)(3)(i) through (iii) of this section to calculate percent reduction efficiency.

(i) You must compute the mass rate of TOC using the following equations:

Equations 1 and 2 to paragraph (b)(3)(i)

$$E_i = K_2 C_i M_p Q_i$$

$$E_o = K_2 C_o M_p Q_o$$

Where:

E_i , E_o = Mass rate of TOC at the inlet and outlet of the control device, respectively, dry basis, kilograms per hour.

K_2 = Constant, 2.494×10^{-6} (parts per million) (gram-mole per standard cubic meter) (kilogram/gram) (minute/hour), where standard temperature (gram-mole

per standard cubic meter) is 20 degrees Celsius.

C_i , C_o = Concentration of TOC, as propane, of the gas stream as measured by Method 25A of appendix A-7 to this part at the inlet and outlet of the control device, respectively, dry basis, parts per million by volume.

M_p = Molecular weight of propane, 44.1 gram/gram-mole.

Q_i , Q_o = Flow rate of gas stream at the inlet and outlet of the control device, respectively, dry standard cubic meter per minute.

(ii) You must calculate the percent reduction in TOC as follows:

Equation 3 to paragraph (b)(3)(ii)

$$R_{cd} = \frac{E_i - E_o}{E_i} \times 100\%$$

Where:

R_{cd} = Control efficiency of control device, percent.

E_i , = Mass rate of TOC at the inlet to the control device as calculated under paragraph (b)(3)(i) of this section, kilograms per hour.

E_o = Mass rate of TOC at the outlet of the control device, as calculated under paragraph (b)(3)(i) of this section, kilograms per hour.

(iii) If the vent stream entering a boiler or process heater with a design capacity less than 44 megawatts is introduced with the combustion air or

as a secondary fuel, you must determine the weight-percent reduction of total TOC across the device by comparing the TOC in all combusted vent streams and primary and secondary fuels with the TOC exiting the device, respectively.

(4) You must use Method 25A of appendix A-7 to this part to measure TOC, as propane, to determine compliance with the TOC exhaust gas concentration limit specified in § 60.5412b(a)(1)(i). You must determine the concentration in parts per million by volume on a wet basis and correct it to 3 percent oxygen. You must use the

emission rate correction factor for excess air, integrated sampling and analysis procedures of Method 3A or 3B of appendix A-2 to this part, ASTM D6522-20, or ANSI/ASME PTC 19.10-1981, Part 10 (manual portion only) (both incorporated by reference, see § 60.17) to determine the oxygen concentration. The samples must be taken during the same time that the samples are taken for determining TOC concentration. You must correct the TOC concentration for percent oxygen as follows:

Equation 4 to paragraph (b)(4)

$$C_c = C_m \left(\frac{17.9}{20.9 - \%O_{2m}} \right)$$

Where:

C_c = TOC concentration, as propane, corrected to 3 percent oxygen, parts per million by volume on a wet basis.

C_m = TOC concentration, as propane, parts per million by volume on a wet basis.

$\%O_{2m}$ = Concentration of oxygen, percent by volume as measured, wet.

(5) You must conduct performance tests according to the schedule specified in paragraphs (b)(5)(i) through (iii) of this section.

(i) You must conduct an initial performance test within 180 days after initial startup for your affected facility. You must submit the performance test results as required in § 60.5420b(b)(12).

(ii) You must conduct periodic performance tests for all control devices required to conduct initial performance tests. You must conduct the first periodic performance test no later than 60 months after the initial performance test required in paragraph (b)(5)(i) of this section. You must conduct subsequent periodic performance tests at intervals no longer than 60 months following the previous periodic

performance test or whenever you desire to establish a new operating limit. If a control device is not operational at the time a performance test is due, you must conduct the performance test no later than 30 calendar days after returning the control device to service. You must submit the periodic performance test results as specified in § 60.5420b(b)(12).

(iii) If the initial performance test was conducted by the manufacturer under paragraph (d) of this section, you must conduct the first periodic performance test no later than 60 months after initial installation and startup of the control device. You must conduct subsequent periodic performance tests at intervals no longer than 60 months following the previous periodic performance test. If a control device is not operational at the time a performance test is due, you must conduct the performance test no later than 30 calendar days after returning the control device to service. You must submit the periodic performance test results as specified in § 60.5420b(b)(12).

(c) *Control device design analysis to meet the requirements of § 60.5412b(a)(2).* (1) For a condenser, the design analysis must include an analysis of the vent stream composition, constituent concentrations, flow rate, relative humidity, and temperature and must establish the design outlet organic compound concentration level, design average temperature of the condenser exhaust vent stream and the design average temperatures of the coolant fluid at the condenser inlet and outlet.

(2) For a regenerable carbon adsorption system, the design analysis shall include the vent stream composition, constituent concentrations, flow rate, relative humidity and temperature and shall establish the design exhaust vent stream organic compound concentration level, adsorption cycle time, number and capacity of carbon beds, type and working capacity of activated carbon used for the carbon beds, design total regeneration stream flow over the period of each complete carbon bed

regeneration cycle, design carbon bed temperature after regeneration, design carbon bed regeneration time and design service life of the carbon.

(3) For a nonregenerable carbon adsorption system, such as a carbon canister, the design analysis shall include the vent stream composition, constituent concentrations, flow rate, relative humidity and temperature and shall establish the design exhaust vent stream organic compound concentration level, capacity of the carbon bed, type and working capacity of activated carbon used for the carbon bed and design carbon replacement interval based on the total carbon working capacity of the control device and source operating schedule. In addition, these systems shall incorporate dual carbon canisters in case of emission breakthrough occurring in one canister.

(4) If you and the Administrator do not agree on a demonstration of control device performance using a design analysis, then you must perform a performance test in accordance with the requirements of paragraph (b) of this section to resolve the disagreement. The Administrator may choose to have an authorized representative observe the performance test.

(d) *Performance testing for combustion control devices—manufacturers' performance test.* (1) This paragraph (d) applies to the performance testing of a combustion control device conducted by the device manufacturer. The manufacturer must demonstrate that a specific model of control device achieves the performance requirements in paragraph (d)(11) of this section by conducting a performance test as specified in paragraphs (d)(2) through (10) of this section. You must submit a test report for each combustion control device in accordance with the requirements in paragraph (d)(12) of this section.

(2) Performance testing must consist of three 1-hour (or longer) test runs for each of the four firing rate settings specified in paragraphs (d)(2)(i) through (iv) of this section, making a total of 12 test runs per test. Propene (propylene) gas must be used for the testing fuel. All fuel analyses must be performed by an independent third-party laboratory (not affiliated with the control device manufacturer or fuel supplier).

(i) 90–100 percent of maximum design rate (fixed rate).

(ii) 70–100–70 percent (ramp up, ramp down). Begin the test at 70 percent of the maximum design rate. During the first 5 minutes, incrementally ramp the firing rate to 100 percent of the maximum design rate. Hold at 100 percent for 5 minutes. In the 10- to 15-

minute time range, incrementally ramp back down to 70 percent of the maximum design rate. Repeat three more times for a total of 60 minutes of sampling.

(iii) 30–70–30 percent (ramp up, ramp down). Begin the test at 30 percent of the maximum design rate. During the first 5 minutes, incrementally ramp the firing rate to 70 percent of the maximum design rate. Hold at 70 percent for 5 minutes. In the 10- to 15-minute time range, incrementally ramp back down to 30 percent of the maximum design rate. Repeat three more times for a total of 60 minutes of sampling.

(iv) 0–30–0 percent (ramp up, ramp down). Begin the test at the minimum firing rate. During the first 5 minutes, incrementally ramp the firing rate to 30 percent of the maximum design rate. Hold at 30 percent for 5 minutes. In the 10- to 15-minute time range, incrementally ramp back down to the minimum firing rate. Repeat three more times for a total of 60 minutes of sampling.

(3) All models employing multiple enclosures must be tested simultaneously and with all burners operational. Results must be reported for each enclosure individually and for the average of the emissions from all interconnected combustion enclosures/chambers. Control device operating data must be collected continuously throughout the performance test using an electronic Data Acquisition System. A graphic presentation or strip chart of the control device operating data and emissions test data must be included in the test report in accordance with paragraph (d)(12) of this section. Inlet fuel meter data may be manually recorded provided that all inlet fuel data readings are included in the final report.

(4) Inlet testing must be conducted as specified in paragraphs (d)(4)(i) and (ii) of this section.

(i) The inlet gas flow metering system must be located in accordance with Method 2A of appendix A–1 of this part (or other approved procedure) to measure inlet gas flow rate at the control device inlet location. You must position the fitting for filling fuel sample containers a minimum of eight pipe diameters upstream of any inlet gas flow monitoring meter.

(ii) Inlet flow rate must be determined using Method 2A to appendix A–1 of this part. Record the start and stop reading for each 60-minute THC test. Record the gas pressure and temperature at 5-minute intervals throughout each 60-minute test.

(5) Inlet gas sampling must be conducted as specified in paragraphs (d)(5)(i) and (ii) of this section.

(i) At the inlet gas sampling location, securely connect a fused silica-coated stainless steel evacuated canister fitted with a flow controller sufficient to fill the canister over a 3-hour period. Filling must be conducted as specified in paragraphs (d)(5)(i)(A) through (C) of this section.

(A) Open the canister sampling valve at the beginning of each test run and close the canister at the end of each test run.

(B) Fill one canister across the three test runs such that one composite fuel sample exists for each test condition.

(C) Label the canisters individually and record sample information on a chain of custody form.

(ii) Analyze each inlet gas sample using the methods in paragraphs (d)(5)(ii)(A) through (C) of this section. You must include the results in the test report required by paragraph (d)(12) of this section.

(A) Hydrocarbon compounds containing between one and five atoms of carbon plus benzene using ASTM D1945–03(R2010) (incorporated by reference, see § 60.17).

(B) Hydrogen (H₂), carbon monoxide (CO), carbon dioxide (CO₂), nitrogen (N₂), oxygen (O₂) using ASTM D1945–03(R2010) (incorporated by reference, see § 60.17).

(C) Higher heating value using ASTM D3588–98(R2003) or ASTM D4891–89(R2006) (both incorporated by reference, see § 60.17).

(6) Outlet testing must be conducted in accordance with the criteria in paragraphs (d)(6)(i) through (v) of this section.

(i) Sample and flow rate must be measured in accordance with paragraphs (d)(6)(i)(A) and (B) of this section.

(A) The outlet sampling location must be a minimum of four equivalent stack diameters downstream from the highest peak flame or any other flow disturbance, and a minimum of one equivalent stack diameter upstream of the exit or any other flow disturbance. A minimum of two sample ports must be used.

(B) Flow rate must be measured using Method 1 of appendix A–1 to this part for determining flow measurement traverse point location, and Method 2 of appendix A–1 to this part for measuring duct velocity. If low flow conditions are encountered (*i.e.*, velocity pressure differentials less than 0.05 inches of water) during the performance test, a more sensitive manometer must be used to obtain an accurate flow profile.

(ii) Molecular weight and excess air must be determined as specified in paragraph (d)(7) of this section.

(iii) Carbon monoxide must be determined as specified in paragraph (d)(8) of this section.

(iv) THC must be determined as specified in paragraph (d)(9) of this section.

(v) Visible emissions must be determined as specified in paragraph (d)(10) of this section.

(7) Molecular weight and excess air determination must be performed as specified in paragraphs (d)(7)(i) through (iii) of this section.

(i) An integrated bag sample must be collected during the moisture test required by Method 4 of appendix A-3 to this part following the procedure specified in (d)(7)(i)(A) and (B) of this section. Analyze the bag sample using a gas chromatograph-thermal conductivity detector (GC-TCD) analysis meeting the criteria in paragraphs (d)(7)(i)(C) and (D) of this section.

(A) Collect the integrated sample throughout the entire test and collect representative volumes from each traverse location.

(B) Purge the sampling line with stack gas before opening the valve and beginning to fill the bag. Clearly label each bag and record sample information on a chain of custody form.

(C) The bag contents must be vigorously mixed prior to the gas chromatograph analysis.

(D) The GC-TCD calibration procedure in Method 3C of appendix A-2 to this part must be modified as

follows: For the initial calibration, triplicate injections of any single concentration must agree within 5 percent of their mean to be valid. The calibration response factor for a single concentration re-check must be within 10 percent of the original calibration response factor for that concentration. If this criterion is not met, repeat the initial calibration using at least three concentration levels.

(ii) Calculate and report the molecular weight of oxygen, carbon dioxide, methane and nitrogen in the integrated bag sample and include in the test report specified in paragraph (d)(12) of this section. Moisture must be determined using Method 4 of appendix A-3 to this part. Traverse both ports with the sampling train required by Method 4 of appendix A-3 to this part during each test run. Ambient air must not be introduced into the integrated bag sample required by Method 3C of appendix A-2 to this part during the port change.

(iii) Excess air must be determined using resultant data from the Method 3C tests and Method 3B of appendix A-2 to this part, equation 3B-1 in Method 3B, or ANSI/ASME PTC 19.10-1981, Part 10 (manual portion only) (incorporated by reference, see § 60.17).

(8) Carbon monoxide must be determined using Method 10 of appendix A-4 to this part. Run the test simultaneously with Method 25A of appendix A-7 to this part using the

same sampling points. An instrument range of 0-10 parts per million by volume-dry (ppmvd) is recommended.

(9) Total hydrocarbon determination must be performed as specified by in paragraphs (d)(9)(i) through (vii) of this section.

(i) Conduct THC sampling using Method 25A of appendix A-7 to this part, except that the option for locating the probe in the center 10 percent of the stack is not allowed. The THC probe must be traversed to 16.7 percent, 50 percent, and 83.3 percent of the stack diameter during each test run.

(ii) A valid test must consist of three Method 25A tests, each no less than 60 minutes in duration.

(iii) A 0 to 10 parts per million by volume-wet (ppmvw) (as propane) measurement range is preferred; as an alternative a 0 to 30 ppmvw (as propane) measurement range may be used.

(iv) Calibration gases must be propane in air and be certified through EPA-600/R-12/531—"EPA Traceability Protocol for Assay and Certification of Gaseous Calibration Standards," (incorporated by reference, see § 60.17).

(v) THC measurements must be reported in terms of ppmvw as propane.

(vi) THC results must be corrected to 3 percent CO₂, as measured by Method 3C of appendix A-2 to this part. You must use the following equation for this diluent concentration correction:

Equation 5 to paragraph (d)(9)(vi)

$$C_{corr} = C_{meas} \left(\frac{3}{CO_{2meas}} \right)$$

Where:

C_{meas} = The measured concentration of the pollutant.

CO_{2meas} = The measured concentration of the CO₂ diluent.

3 = The corrected reference concentration of CO₂ diluent.

C_{corr} = The corrected concentration of the pollutant.

(vii) Subtraction of methane or ethane from the THC data is not allowed in determining results.

(10) Visible emissions must be determined using Method 22 of appendix A-7 to this part. The test must be performed continuously during each test run. A digital color photograph of the exhaust point, taken from the position of the observer and annotated with date and time, must be taken once per test run and the 12 photos included

in the test report specified in paragraph (d)(12) of this section.

(11)(i) The control device model tested must meet the criteria in paragraphs (d)(11)(i)(A) through (D) of this section. These criteria must be reported in the test report required by paragraph (d)(12) of this section.

(A) Results from Method 22 of appendix A-7 to this part determined under paragraph (d)(10) of this section with no indication of visible emissions.

(B) Average results from Method 25A of appendix A-7 to this part determined under paragraph (d)(9) of this section equal to or less than 10.0 ppmvw THC as propane corrected to 3.0 percent CO₂.

(C) Average CO emissions determined under paragraph (d)(8) of this section equal to or less than 10 parts ppmvd, corrected to 3.0 percent CO₂.

(D) Excess air determined under paragraph (d)(7) of this section equal to or greater than 150 percent.

(ii) The manufacturer must determine a minimum inlet gas flow rate above which each control device model must be operated to achieve the criteria in paragraph (d)(11)(iii) of this section. The manufacturer must determine a maximum inlet gas flow rate which must not be exceeded for each control device model to achieve the criteria in paragraph (d)(11)(iii) of this section. The minimum and maximum inlet gas flow rate must be included in the test report required by paragraph (d)(12) of this section.

(iii) A manufacturer must demonstrate a destruction efficiency of at least 95.0 percent for THC, as propane. A control device model that demonstrates a

destruction efficiency of 95.0 percent for THC, as propane, will meet the control requirement for 95.0 percent destruction of VOC and methane required under this subpart.

(12) The owner or operator of a combustion control device model tested under this paragraph (d)(12) must submit the information listed in paragraphs (d)(12)(i) through (vi) of this section for each test run in the test report required by this section in accordance with § 60.5420b(b)(13). Owners or operators who claim that any of the performance test information being submitted is confidential business information (CBI) must submit a complete file including information claimed to be CBI to the OAQPS CBI office. The preferred method to receive CBI is for it to be transmitted electronically using email attachments, File Transfer Protocol, or other online file sharing services. Electronic submissions must be transmitted directly to the OAQPS CBI Office at the email address oaqpscbi@epa.gov and should include clear CBI markings and be flagged to the attention of the Leader, Measurement Policy Group. If assistance is needed with submitting large electronic files that exceed the file size limit for email attachments, and if you do not have your own file sharing service, please email oaqpscbi@epa.gov to request a file transfer link. If you cannot transmit the file electronically, you may send CBI information through the postal service to the following address: U.S. EPA, Attn: OAQPS Document Control Officer and Measurement Policy Group Leader, Mail Drop: C404-02, 109 T.W. Alexander Drive, P.O. Box 12055, RTP, North Carolina 27711. The mailed CBI material should be double wrapped and clearly marked. Any CBI markings should not show through the outer envelope. The same file with the CBI omitted must be submitted to Oil_and_Gas_PT@EPA.GOV.

(i) A full schematic of the control device and dimensions of the device components.

(ii) The maximum net heating value of the device.

(iii) The test fuel gas flow range (in both mass and volume). Include the minimum and maximum allowable inlet gas flow rate.

(iv) The air/stream injection/assist ranges, if used.

(v) The test conditions listed in paragraphs (d)(12)(v)(A) through (O) of this section, as applicable for the tested model.

(A) Fuel gas delivery pressure and temperature.

(B) Fuel gas moisture range.

(C) Purge gas usage range.
(D) Condensate (liquid fuel) separation range.

(E) Combustion zone temperature range. This is required for all devices that measure this parameter.

(F) Excess air range.

(G) Flame arrestor(s).

(H) Burner manifold.

(I) Continuous pilot flame indicator.

(J) Pilot flame design fuel and

calculated or measured fuel usage.

(K) Tip velocity range.

(L) Momentum flux ratio.

(M) Exit temperature range.

(N) Exit flow rate.

(O) Wind velocity and direction.

(vi) The test report must include all calibration quality assurance/quality control data, calibration gas values, gas cylinder certification, strip charts, or other graphic presentations of the data annotated with test times and calibration values.

(e) *Initial and continuous compliance for combustion control devices tested by the manufacturer in accordance with paragraph (d) of this section.* This paragraph (e) applies to the demonstration of compliance for a combustion control device tested under the provisions in paragraph (d) of this section. Owners or operators must demonstrate that a control device achieves the performance criteria in paragraph (d)(11) of this section by installing a device tested under paragraph (d) of this section, complying with the criteria specified in paragraphs (e)(1) through (10) of this section, maintaining the records specified in § 60.5420b(c)(11) and submitting the report specified in § 60.5420b(b)(11)(v) and (13).

(1) The inlet gas flow rate must be equal to or greater than the minimum inlet gas flow rate and equal to or less than the maximum inlet gas flow rate specified by the manufacturer.

(2) A pilot or combustion flame must be present at all times of operation. An alert must be sent to the nearest control room whenever the pilot or combustion flame is unlit.

(3) Devices must be operated with no visible emissions, except for periods not to exceed a total of 1 minute during any 15-minute period. A visible emissions test conducted according to section 11 of Method 22 of appendix A-7 to this part must be performed at least once every calendar month, separated by at least 15 days between each test. The observation period shall be 15 minutes or once the amount of time visible emissions is present has exceeded 1 minute, whichever time period is less. Alternatively, you may conduct visible emissions monitoring according to § 60.5417b(h).

(4) Devices failing the visible emissions test must follow manufacturer's repair instructions, if available, or best combustion engineering practice as outlined in the unit inspection and maintenance plan, to return the unit to compliant operation. All repairs and maintenance activities for each unit must be recorded in a maintenance and repair log and must be available for inspection.

(5) Following return to operation from maintenance or repair activity, each device must pass a visual observation according to Method 22 of appendix A-7 to this part as described in paragraph (e)(3) of this section or be monitored according to § 60.5417b(h).

(6) If the owner or operator operates a combustion control device model tested under this section, an electronic copy of the performance test results required by this section shall be submitted via email to Oil_and_Gas_PT@EPA.GOV unless the test results for that model of combustion control device are posted at the following website: <https://www.epa.gov/controlling-air-pollution-oil-and-natural-gas-industry>.

(7) Ensure that each enclosed combustion device is maintained in a leak free condition.

(8) Operate each control device following the manufacturer's written operating instructions, procedures and maintenance schedule to ensure good air pollution control practices for minimizing emissions.

(9) Install and operate the continuous parameter monitoring systems in accordance with § 60.5417b(a) and (c) through (i).

(10) Comply with the applicable NHV limit specified in § 60.5412b(a)(1)(iv).

§ 60.5415b How do I demonstrate continuous compliance with the standards for each of my affected facilities?

(a) *Well completion standards for well affected facility.* For each well completion operation at your well affected facility, you must demonstrate continuous compliance with the requirements of § 60.5375b by submitting the annual report required by § 60.5420b(b)(1) and (2) and maintaining the records for each completion operation specified in § 60.5420b(c)(1).

(b) *Gas well liquids unloading standards for well affected facility.* For each well liquids unloading operation at your well affected facility, you must demonstrate continuous compliance with the requirements of § 60.5376b by submitting the annual report information specified in § 60.5420b(b)(1) and (3) and maintaining the records for each well liquids

unloading event specified in § 60.5420b(c)(2). For each gas well liquids unloading well affected facility that complies with the requirements of § 60.5376b(g), you must route emissions to a control device through a closed vent system and continuously comply with the closed vent requirements of § 60.5416b. You also must comply with the requirements specified in paragraph (f) of this section and maintain the records in § 60.5420b(c)(8), (10) and (12).

(c) *Associated gas well standards for well affected facility.* For each associated gas well, you must demonstrate continuous compliance with the requirements of § 60.5377b by submitting the reports required by § 60.5420b(b)(1) and (4) and maintaining the records specified in § 60.5420b(c)(3). For each associated gas well that complies with the requirements of § 60.5377b(d) or (f), you must route emissions to a control device through a closed vent system and continuously comply with the closed vent requirements of § 60.5416b. You also must comply with the requirements specified in paragraph (f) of this section and maintain the records in § 60.5420b(c)(8), (10) and (12).

(d) *Centrifugal compressor affected facility.* For each wet seal centrifugal compressor affected facility complying with § 60.5380b(a)(1) and (2), or with § 60.5380b(a)(3) by routing emissions to a control device or to a process, you must demonstrate continuous compliance according to paragraph (d)(1) and paragraphs (d)(3) and (4) of this section. For each self-contained wet seal centrifugal compressor complying with the requirements in § 60.5380b(a)(4), you must demonstrate continuous compliance according to paragraphs (d)(2) through (4) of this section. For each centrifugal compressor on the Alaska North Slope equipped with sour seal oil separator and capture system, complying with the requirements of § 60.5380b(a)(5), you must demonstrate continuous compliance according to paragraphs (d)(2) through (4) of this section. For each dry seal centrifugal compressor complying with the requirements in § 60.5380b(a)(6), you must demonstrate continuous compliance according to paragraphs (d)(2) through (4) of this section.

(1) For each wet seal centrifugal compressor affected facility complying by routing emissions to a control device or to a process, you must operate the wet seal emissions collection system to route emissions to a control device or a process through a closed vent system and continuously comply with the cover

and closed vent requirements of § 60.5416b. If you comply with § 60.5380b(a)(2) by using a control device, you also must comply with the requirements in paragraph (f) of this section.

(2) You must maintain volumetric flow rate at or below the flow rates specified in § 60.5380b(a)(5) for you centrifugal compressor and you must conduct the required volumetric flow rate measurement of your self-contained wet seal centrifugal compressor, Alaska North Slope centrifugal compressor equipped with sour seal oil separator and capture system, or dry seal centrifugal compressor in accordance with § 60.5380b(a)(6) on or before 8,760 hours of operation after your last volumetric flow rate measurement which demonstrates compliance with the volumetric flow rate specified in § 60.5380b(a)(5) for you centrifugal compressor.

(3) You must submit the annual reports as required in § 60.5420b(b)(1), (5), and (11)(i) through (iv), as applicable.

(4) You must maintain records as required in § 60.5420b(c)(4), (8) through (10), and (12), as applicable.

(e) *Pump affected facility.* To demonstrate continuous compliance with the GHG and VOC standards for your pump affected facility as required by § 60.5393b, you must comply with paragraphs (e)(1) through (3) of this section.

(1) For pump affected facilities complying with the requirements of § 60.5393b(a) by routing emissions to a process, and for pump affected facilities complying with the requirements of § 60.5393b(b)(2), or (3), you must continuously comply with the closed vent requirements of § 60.5416b. If you comply with § 60.5393b(b)(3), you also must comply with the requirements in paragraph (f) of this section.

(2) You must submit the annual reports for your pump affected facility as required in § 60.5420b(b)(1), (10), and (11)(i) through (iv), as applicable.

(3) You must maintain the records for your pump affected facility as specified in § 60.5420b(c)(8), (10), (12), and (15), as applicable.

(f) *Additional continuous compliance requirements for well, centrifugal compressor, reciprocating compressor, process controllers in Alaska, storage vessel, process unit equipment, or pump affected facilities.* For each associated gas well, each gas well that conducts liquids unloading, each centrifugal compressor affected facility, each reciprocating compressor affected facility, each process controller affected facility in Alaska, each storage vessel

affected facility, each process unit equipment affected facility, and each pump affected facility referenced to this paragraph from either paragraph (b), (c), (d)(1), (e)(1), (g), (h)(2)(iv), (i) or (j) of this section, you must also install monitoring systems as specified in § 60.5417b, demonstrate continuous compliance according to paragraph (f)(1) of this section, maintain the records in paragraph (f)(2) of this section, and comply with the reporting requirements specified in paragraph (f)(3) of this section.

(1) You must demonstrate continuous compliance with the control device performance requirements of § 60.5412b(a) using the procedures specified in paragraphs (f)(1)(i) through (viii) of this section and conducting the monitoring as required by § 60.5417b. If you use a condenser as the control device to achieve the requirements specified in § 60.5412b(a)(2), you may demonstrate compliance according to paragraph (f)(1)(ix) of this section. You may switch between compliance with paragraphs (f)(1)(i) through (viii) of this section and compliance with paragraph (f)(1)(ix) of this section only after at least 1 year of operation in compliance with the selected approach. You must provide notification of such a change in the compliance method in the next annual report, following the change. If you use an enclosed combustion device or a flare as the control device, you must also conduct the monitoring required in paragraph (f)(1)(x) of this section. If you use an enclosed combustion device or flare using an alternative test method approved under § 60.5412b(d), you must use the procedures in paragraph (f)(1)(xi) of this section in lieu of the procedures in paragraphs (f)(1)(i) through (viii) of this section, but you must still conduct the monitoring required in paragraph (f)(1)(x) of this section.

(i) You must operate below (or above) the site-specific maximum (or minimum) parameter value established according to the requirements of § 60.5417b(f)(1). For flares, you must operate above the limits specified in paragraphs (f)(1)(vii)(B) of this section.

(ii) You must calculate the average of the applicable monitored parameter in accordance with § 60.5417b(e).

(iii) Compliance with the operating parameter limit is achieved when the average of the monitoring parameter value calculated under paragraph (f)(1)(ii) of this section is either equal to or greater than the minimum parameter value or equal to or less than the maximum parameter value established under paragraph (f)(1)(i) of this section. When performance testing of a

combustion control device is conducted by the device manufacturer as specified in § 60.5413b(d), compliance with the operating parameter limit is achieved when the criteria in § 60.5413b(e) are met.

(iv) You must operate the continuous monitoring system required in § 60.5417b(a) at all times the affected source is operating, except for periods of monitoring system malfunctions, repairs associated with monitoring system malfunctions and required monitoring system quality assurance or quality control activities, including, as applicable, system accuracy audits and required zero and span adjustments. A monitoring system malfunction is any sudden, infrequent, not reasonably preventable failure of the monitoring system to provide valid data. Monitoring system failures that are caused in part by poor maintenance or careless operation are not malfunctions. You are required to complete monitoring system repairs in response to monitoring system malfunctions and to return the monitoring system to operation as expeditiously as practicable.

(v) You may not use data recorded during monitoring system malfunctions, repairs associated with monitoring system malfunctions, or required monitoring system quality assurance or control activities in calculations used to report emissions or operating levels. You must use all the data collected during all other required data collection periods to assess the operation of the control device and associated control system.

(vi) Failure to collect required data is a deviation of the monitoring requirements.

(vii) If you use an enclosed combustion device to meet the requirements of § 60.5412b(a)(1) and you demonstrate compliance using the test procedures specified in § 60.5413b(b), or you use a flare designed and operated in accordance with § 60.5412b(a)(3), you must comply with the applicable requirements in paragraphs (f)(1)(vii)(A) through (E) of this section.

(A) For each enclosed combustion device which is not a catalytic vapor incinerator and for each flare, you must comply with the requirements in paragraphs (f)(1)(vii)(A)(1) through (4) of this section.

(1) A pilot or combustion flame must be present at all times of operation. An alert must be sent to the nearest control room whenever the pilot or combustion flame is unlit.

(2) Devices must be operated with no visible emissions, except for periods not

to exceed a total of 1 minute during any 15-minute period. A visible emissions test conducted according to section 11 of Method 22 of appendix A-7 to this part, must be performed at least once every calendar month, separated by at least 15 days between each test. The observation period shall be 15 minutes or once the amount of time visible emissions is present has exceeded 1 minute, whichever time period is less. Alternatively, you may conduct visible emissions monitoring according to § 60.5417b(h).

(3) Devices failing the visible emissions test must follow manufacturer's repair instructions, if available, or best combustion engineering practice as outlined in the unit inspection and maintenance plan, to return the unit to compliant operation. All repairs and maintenance activities for each unit must be recorded in a maintenance and repair log and must be available for inspection.

(4) Following return to operation from maintenance or repair activity, each device must pass a Method 22 of appendix A-7 to this part visual observation as described in paragraph (f)(1)(vii)(D) of this section or be monitored according to § 60.5417b(h).

(B) For flares, you must comply with the requirements in paragraphs (f)(1)(vii)(B)(1) through (6) of this section.

(1) For unassisted flares, maintain the NHV of the gas sent to the flare at or above 200 Btu/scf.

(2) If you use a pressure assisted flare, maintain the NHV of gas sent to the flare at or above 800 Btu/scf.

(3) For steam-assisted and air-assisted flares, maintain the NHV_{cz} at or above 270 Btu/scf.

(4) For flares with perimeter assist air, maintain the NHV_{dil} at or above 22 Btu/sqft. If the only assist air provided to the flare is perimeter assist air intentionally entrained in lower and/or upper steam at the flare tip and the effective diameter is 9 inches or greater, you are not required to comply with the NHV_{dil} limit.

(5) Unless you use a pressure-assisted flare, maintain the flare tip velocity below the applicable limits in § 60.18(b).

(6) Maintain the total gas flow to the flare above the minimum inlet gas flow rate. The minimum inlet gas flow rate is established based on manufacturer recommendations.

(C) For enclosed combustion devices for which, during the performance test conducted under § 60.5413b(b), the combustion zone temperature is not an indicator of destruction efficiency, you must comply with the requirements in

paragraphs (f)(1)(vii)(C)(1) through (5) of this section, as applicable.

(1) Maintain the total gas flow to the enclosed combustion device at or above the minimum inlet gas flow rate and at or below the maximum inlet flow rate for the enclosed combustion device established in accordance with § 60.5417b(f).

(2) For unassisted enclosed combustion devices, maintain the NHV of the gas sent to the enclosed combustion device at or above 200 Btu/scf.

(3) For enclosed combustion devices that use pressure-assisted burner tips to promote mixing at the burner tip, maintain the NHV of the gas sent to the enclosed combustion device at or above 800 Btu/scf.

(4) For steam-assisted and air-assisted enclosed combustion devices, maintain the NHV_{cz} at or above 270 Btu/scf.

(5) For enclosed combustion devices with perimeter assist air, maintain the NHV_{dil} at or above 22 Btu/sqft. If the only assist air provided to the enclosed combustion device is perimeter assist air intentionally entrained in lower and/or upper steam at the flare tip and the effective diameter is 9 inches or greater, you are not required to comply with the NHV_{dil} limit.

(D) For enclosed combustion devices for which, during the performance test conducted under § 60.5413b(b), the combustion zone temperature is demonstrated to be an indicator of destruction efficiency, you must comply with the requirements in paragraphs (f)(1)(vii)(D)(1) and (2) of this section.

(1) Maintain the temperature at or above the minimum temperature established during the most recent performance test. The minimum temperature limit established during the most recent performance test is the average temperature recorded during each test run, averaged across the 3 test runs (average of the test run averages).

(2) Maintain the total gas flow to the enclosed combustion device at or above the minimum inlet gas flow rate and at or below the maximum inlet flow rate for the enclosed combustion device established in accordance with § 60.5417b(f).

(E) For catalytic vapor incinerators you must operate the catalytic vapor incinerator at or above the minimum temperature of the catalyst bed inlet and at or above the minimum temperature differential between the catalyst bed inlet and the catalyst bed outlet established in accordance with § 60.5417b(f).

(viii) If you use a carbon adsorption system as the control device to meet the requirements of § 60.5412b(a)(2), you

must demonstrate compliance by the procedures in paragraphs (f)(1)(viii)(A) and (B) of this section, as applicable.

(A) If you use a regenerative-type carbon adsorption system, you must comply with paragraphs (f)(1)(viii)(A)(1) through (4) of this section.

(1) You must maintain the average regenerative mass flow or volumetric flow to the carbon adsorber during each bed regeneration cycle above the limit established in accordance with § 60.5413b(c)(2).

(2) You must maintain the average carbon bed temperature above the temperature limit established in accordance with § 60.5413b(c)(2) during the carbon bed steaming cycle and below the carbon bed temperature established in accordance with § 60.5413b(c)(2) after the regeneration cycle.

(3) You must check the mechanical connections for leakage at least every month, and you must perform a visual inspection at least every 3 months of all components of the continuous parameter monitoring system for physical and operational integrity and all electrical connections for oxidation and galvanic corrosion if your continuous parameter monitoring system is not equipped with a redundant flow sensor.

(4) You must replace all carbon in the carbon adsorption system with fresh carbon on a regular, predetermined time interval that is no longer than the carbon service life established according to § 60.5413b(c)(2).

(B) If you use a nonregenerative-type carbon adsorption system, you must replace all carbon in the control device with fresh carbon on a regular, predetermined time interval that is no longer than the carbon service life established according to § 60.5413b(c)(3).

(ix) If you use a condenser as the control device to achieve the percent reduction performance requirements specified in § 60.5412b(a)(2), you must demonstrate compliance using the procedures in paragraphs (f)(1)(ix)(A) through (E) of this section.

(A) You must establish a site-specific condenser performance curve according to § 60.5417b(f)(2).

(B) You must calculate the daily average condenser outlet temperature in accordance with § 60.5417b(e).

(C) You must determine the condenser efficiency for the current operating day using the daily average condenser outlet temperature calculated under paragraph (f)(1)(ix)(B) of this section and the condenser performance curve established under paragraph (f)(1)(ix)(A) of this section.

(D) Except as provided in paragraphs (f)(1)(ix)(D)(1) and (2) of this section, at the end of each operating day, you must calculate the 365-day rolling average TOC emission reduction, as appropriate, from the condenser efficiencies as determined in paragraph (f)(1)(ix)(C) of this section.

(1) After the compliance dates specified in § 60.5370b(a), if you have less than 120 days of data for determining average TOC emission reduction, you must calculate the average TOC emission reduction for the first 120 days of operation after the compliance date. You have demonstrated compliance with the overall 95.0 percent reduction requirement if the 120-day average TOC emission reduction is equal to or greater than 95.0 percent.

(2) After 120 days and no more than 364 days of operation after the compliance date specified in § 60.5370b(a), you must calculate the average TOC emission reduction as the TOC emission reduction averaged over the number of days between the current day and the applicable compliance date. You have demonstrated compliance with the overall 95.0 percent reduction requirement if the average TOC emission reduction is equal to or greater than 95.0 percent.

(E) If you have data for 365 days or more of operation, you have demonstrated compliance with the TOC emission reduction if the rolling 365-day average TOC emission reduction calculated in paragraph (f)(1)(ix)(D) of this section is equal to or greater than 95.0 percent.

(x) During each inspection conducted using an OGI camera under § 60.5397b and during each periodic screening event or each inspection conducted using an OGI camera under § 60.5398b, you must observe each enclosed combustion device and flare to determine if it is operating properly. You must determine whether there is a flame present and whether any uncontrolled emissions from the control device are visible with the OGI camera or the technique used to conduct the periodic screening event. During each inspection conducted under § 60.5397b using AVO, you must observe each enclosed combustion device and flare to determine if it is operating properly. Visually confirm that the pilot or combustion flame is lit and that the pilot or combustion flame is operating properly.

(xi) If you use an enclosed combustion device or flare using an alternative test method approved under § 60.5412b(d), you must comply with

paragraphs (f)(1)(xi)(A) through (E) of this section.

(A) You must maintain the combustion efficiency at or above 95.0 percent. Alternatively, if the alternative test method does not directly monitor combustion efficiency, you must comply with the applicable requirements in paragraphs (f)(1)(xi)(A)(1) and (2) of this section.

(1) Maintain the NHV_{cz} at or above 270 Btu/scf.

(2) For flares or enclosed combustion devices with perimeter assist air, maintain the NHV_{di} at or above 22 Btu/sqft. If the only assist air provided to the flare or enclosed combustion device is perimeter assist air intentionally entrained in lower and/or upper steam at the flare tip and the effective diameter is 9 inches or greater, you are only required to comply with the NHV_{cz} limit specified in paragraph (f)(1)(xi)(A)(1) of this section.

(B) You must calculate the value of the applicable monitored metric(s) in accordance with the approved alternative test method. Compliance with the limit is achieved when the calculated values are within the range specified in paragraph (f)(1)(xi)(A) of this section.

(C) You must conduct monitoring using the alternative test method at all times the affected source is operating, except for periods of monitoring system malfunctions, repairs associated with monitoring system malfunctions and required monitoring system quality assurance or quality control activities, including, as applicable, system accuracy audits and required zero and span adjustments. A monitoring system malfunction is any sudden, infrequent, not reasonably preventable failure of the monitoring system to provide valid data. Monitoring system failures that are caused in part by poor maintenance or careless operation are not malfunctions. You are required to complete monitoring system repairs in response to monitoring system malfunctions and to return the monitoring system to operation as expeditiously as practicable.

(D) You may not use data recorded during monitoring system malfunctions, repairs associated with monitoring system malfunctions, or required monitoring system quality assurance or control activities in calculations used to report values to demonstrate compliance with the limits specified in paragraph (f)(1)(xi)(A) of this section. You must use all the data collected during all other required data collection periods to assess the operation of the control device and associated control system.

(E) Failure to collect required data is a deviation of the monitoring requirements.

(2) You must maintain the records as specified in § 60.5420b(c)(11) and (13).

(3) You must comply with the reporting requirements in § 60.5420b(b)(11) through (13).

(g) *Reciprocating compressor affected facility.* For each reciprocating compressor affected facility complying with § 60.5385b(a) through (c), you must demonstrate continuous compliance according to paragraphs (g)(1), (5), and (6) of this section. For each reciprocating compressor affected facility complying with § 60.5385b(d)(1) or (2), you must demonstrate continuous compliance according to paragraphs (g)(2), (5) and (6) of this section. For each reciprocating compressor affected facility complying with § 60.5385b(d)(3), you must demonstrate continuous compliance according to paragraphs (g)(3) through (6) of this section.

(1) You must maintain the volumetric flow rate at or below 2 scfm per cylinder (or at or below the combined volumetric flow rate determined by multiplying the number of cylinders by 2 scfm), and you must conduct the required volumetric flow rate measurement of your reciprocating compressor rod packing vents in accordance with § 60.5385b(b) on or before 8,760 hours of operation after your last volumetric flow rate measurement which demonstrated compliance with the applicable volumetric flow rate.

(2) You must operate the rod packing emissions collection system to route emissions to a control device or to a process through a closed vent system and continuously comply with the cover and closed vent requirements of § 60.5416b. If you comply with § 60.5385b(d) by using a control device, you also must comply with the requirements in paragraph (f) of this section.

(3) You must continuously monitor the number of hours of operation for each reciprocating compressor affected facility since initial startup, since May 7, 2024, since the previous flow rate measurement, or since the date of the most recent reciprocating compressor rod packing replacement, whichever date is latest.

(4) You must replace the reciprocating compressor rod packing on or before the total number of hours of operation reaches 8,760 hours.

(5) You must submit the annual reports as required in § 60.5420b(b)(1), (6), and (11)(i) through (iv), as applicable.

(6) You must maintain records as required in § 60.5420b(c)(5), (8) through (10), and (12), as applicable.

(h) *Process controller affected facility.* To demonstrate continuous compliance with GHG and VOC emission standards for your process controller affected facility as required by § 60.5390b, you must comply with paragraphs (h)(1) through (4) of this section, as applicable.

(1) You must demonstrate that your process controller affected facility does not emit any VOC or methane to the atmosphere by meeting the requirements of paragraphs (h)(1)(i) or (ii) of this section.

(i) If you comply by routing the emissions to a process, you must comply with the closed vent system inspection and monitoring requirements of § 60.5416b.

(ii) If you comply by using a self-contained natural gas-driven process controller, you must conduct the no identifiable emissions inspections required by § 60.5416b(b).

(2) For each process controller affected facility located at a site in Alaska that does not have access to electrical power and that complies by reducing methane and VOC emissions from all controllers in the process controller affected facility by 95.0 percent in accordance with § 60.5390b(b)(3), you must comply with the closed vent requirements of § 60.5416b and the requirements in paragraph (f) of this section for the control device.

(3) You must submit the annual report for your process controller as required in § 60.5420b(b)(1), (7), and (11)(i) through (iv), as applicable.

(4) You must maintain the records as specified in § 60.5420b(c)(6), (8), (10), and (12) for each process controller affected facility, as applicable.

(i) *Storage vessel affected facility.* For each storage vessel affected facility, you must demonstrate continuous compliance with the requirements of § 60.5395b according to paragraphs (i)(1) through (10) of this section, as applicable.

(1) For each storage vessel affected facility complying with the requirements of § 60.5395b(a)(2), you must demonstrate continuous compliance according to paragraphs (i)(5), (9) and (10) of this section.

(2) For each storage vessel affected facility complying with the requirements of § 60.5395b(a)(3), you must demonstrate continuous compliance according to paragraphs (i)(2)(i), (ii), or (iii) of this section, as applicable, and (i)(9) and (10) of this section.

(i) You must maintain the uncontrolled actual VOC emissions at less than 4 tpy and the uncontrolled actual methane emissions at less than 14 tpy from the storage vessel affected facility.

(ii) You must comply with paragraph (i)(5) of this section as soon as liquids from the well are routed to the storage vessel affected facility following fracturing or refracturing according to the requirements of § 60.5395b(a)(3)(i).

(iii) You must comply with paragraph (i)(5) of this section within 30 days of the monthly determination according to the requirements of § 60.5395b(a)(3)(ii), where the monthly emissions determination indicates that VOC emissions from your storage vessel affected facility increase to 4 tpy or greater and the increase is not associated with fracturing or refracturing of a well feeding the storage vessel affected facility.

(3) For each storage vessel affected facility or portion of a storage vessel affected facility removed from service, you must demonstrate compliance with the requirements of § 60.5395b(c)(1) by complying with paragraphs (i)(6), (7), (9), and (10) of this section.

(4) For each storage vessel affected facility or portion of a storage vessel affected facility returned to service, you must demonstrate compliance with the requirements of § 60.5395b(c)(1) by complying with paragraphs (i)(8) through (10) of this section.

(5) For each storage vessel affected facility, you must comply with paragraphs (i)(5)(i) and (ii) of this section.

(i) You must reduce VOC emissions as specified in § 60.5395b(a)(2).

(ii) For each control device installed to meet the requirements of § 60.5395b(a)(2), you must demonstrate continuous compliance with the performance requirements of § 60.5412b for each storage vessel affected facility using the procedure specified in paragraphs (i)(5)(ii)(A) and (i)(5)(ii)(B) of this section. When routing emissions to a process, you must demonstrate continuous compliance as specified in paragraph (i)(5)(ii)(A) of this section.

(A) You must comply with § 60.5416b for each cover and closed vent system.

(B) You must comply with the requirements specified in paragraph (f) of this section.

(6) You must completely empty and degas each storage vessel, such that each storage vessel no longer contains crude oil, condensate, produced water or intermediate hydrocarbon liquids. For a portion of a storage vessel affected facility to be removed from service, you must completely empty and degas the

storage vessel(s), such that the storage vessel(s) no longer contains crude oil, condensate, produced water, or intermediate hydrocarbon liquids. A storage vessel where liquid is left on walls, as bottom clingage, or in pools due to floor irregularity is considered to be completely empty.

(7) You must disconnect the storage vessel(s) from the tank battery by isolating the storage vessel(s) from the tank battery such that the storage vessel(s) is no longer manifolded to the tank battery by liquid or vapor transfer.

(8) You must determine the affected facility status of a storage vessel returned to service as provided in § 60.5365b(e)(6).

(9) You must submit the annual reports as required by § 60.5420b(b)(1), (8), and (11)(i) through (iv).

(10) You must maintain the records as required by § 60.5420b(c)(7) through (10) and (c)(12), as applicable.

(j) *Process unit equipment affected facility.* For each process unit equipment affected facility, you must demonstrate continuous compliance with the requirements of § 60.5400b according to paragraphs (j)(1) through (4) and (11) through (15) of this section, unless you meet and comply with the exception in § 60.5402b(b), (e), or (f) or meet the exemption in § 60.5402b(c). Alternatively, if you comply with the GHG and VOC standards for process unit affected facilities using the standards in § 60.5401b, you must comply with paragraphs (j)(5) through (15) of this section, unless you meet the exemption in § 60.5402b(b) or (c) or the exception in § 60.5402b(e) and (f).

(1) You must conduct monitoring for each pump in light liquid service, pressure relief device in gas/vapor service, valve in gas/vapor and light liquid service and connector in gas/vapor and light liquid service as required by § 60.5400b(b).

(2) You must conduct monitoring as required by § 60.5400b(c) for each pump in light liquid service.

(3) You must conduct monitoring as required by § 60.5400b(d) for each pressure relief device in gas/vapor service.

(4) You must comply with the equipment requirements for each open-ended valve or line as required by § 60.5400b(e).

(5) You must conduct monitoring for each pump in light liquid service as required by § 60.5401b(b).

(6) You must conduct monitoring for each pressure relief device in gas/vapor service as required by § 60.5401b(c).

(7) You must comply with the equipment requirements for each open-

ended valve or line as required by § 60.5401b(d).

(8) You must conduct monitoring for each valve in gas/vapor or light liquid service as required by § 60.5401b(f).

(9) You must conduct monitoring for each pump, valve, and connector in heavy liquid service and each pressure relief device in light liquid or heavy liquid service as required by § 60.5401b(g).

(10) You must conduct monitoring for each connector in gas/vapor or light liquid service as required by § 60.5401b(h).

(11) You must collect emissions and meet the closed vent system requirements as required by § 60.5416b for each pump equipped with a dual mechanical seal system that degasses the barrier fluid reservoir to a process or a control device, each pump which captures and transports leakage from the seal or seals to a process or control device, or each pressure relief device which captures and transports leakage through the pressure relief device to a process or control device.

(12) You comply with the requirements specified in paragraph (f) of this section.

(13) You must tag and repair each identified leak as required in § 60.5400(h) or § 60.5401b(i), as applicable.

(14) You must submit semiannual reports as required by § 60.5422b and the annual reports in § 60.5420b(b)(11)(i) through (iv), as applicable.

(15) You must maintain the records specified by § 60.5420b(c)(8), (c)(10), and (c)(12) as applicable and § 60.5421b.

(k) *Sweetening unit affected facility.* For each sweetening unit affected facility, you must demonstrate continuous compliance with the requirements of § 60.5405b(b) according to paragraphs (k)(1) through (10) of this section.

(1) You must determine the minimum required continuous reduction efficiency of SO₂ emissions (Z_c) as required by § 60.5406b(b).

(2) You must determine the emission reduction efficiency (R) achieved by your sulfur reduction technology using the procedures in § 60.5406b(c)(1) through (c)(4).

(3) You must demonstrate compliance with the standard at § 60.5405b(b) by comparing the minimum required sulfur dioxide emission reduction efficiency (Z_c) to the emission reduction efficiency achieved by the sulfur recovery technology (R), where R must be greater than or equal to Z_c.

(4) You must calibrate, maintain, and operate monitoring devices or perform

measurements to determine the accumulation of sulfur product, the H₂S concentration, the average acid gas flow rate, and the sulfur feed rate in accordance with § 60.5407b(a).

(5) You must determine the required SO₂ emissions reduction efficiency each 24-hour period in accordance with § 60.5407b(a), § 60.5407b(d), and § 60.5407b(e), as applicable.

(6) You must calibrate, maintain, and operate monitoring devices and continuous emission monitors in accordance with § 60.5407b(b), (f), and (g), if you use an oxidation control system or a reduction control system followed by an incineration device.

(7) You must continuously operate the incineration device, if you use an oxidation control system or a reduction control system followed by an incineration device.

(8) You must calibrate, maintain, and operate a continuous monitoring system to measure the emission rate of reduced sulfur compounds in accordance with § 60.5407b(c), (f), and (g), if you use a reduction control system not followed by an incineration device.

(9) You must submit the reports as required by § 60.5423b(b) and (d).

(10) You must maintain the records as required by § 60.5423b(a), (e), and (f), as applicable.

(l) *Continuous compliance.* For each fugitive emissions components affected facility, you must demonstrate continuous compliance with the requirements of § 60.5397b(a) according to paragraphs (l)(1) through (4) of this section.

(1) You must conduct periodic monitoring surveys as required in § 60.5397b(e) and (g).

(2) You must repair each identified source of fugitive emissions as required in § 60.5397b(h).

(3) You must submit annual reports for fugitive emissions components affected facilities as required in § 60.5420b(b)(1) and (9).

(4) You must maintain records as specified in § 60.5420b(c)(16).

§ 60.5416b What are the initial and continuous cover and closed vent system inspection and monitoring requirements?

For each closed vent system and cover at your well, centrifugal compressor, reciprocating compressor, process controller, pump, storage vessel, and process unit equipment affected facilities, you must comply with the applicable requirements of paragraphs (a) and (b) of this section. Each self-contained natural gas process controller must comply with paragraph (b) of this section.

(a) *Inspections for closed vent systems, covers, and bypass devices.* If

you install a control device or route emissions to a process, you must inspect each closed vent system according to the procedures and schedule specified in paragraphs (a)(1) and (2) of this section, inspect each cover according to the procedures and schedule specified in paragraph (a)(3) of this section, and inspect each bypass device according to the procedures of paragraph (a)(4) of this section, except as provided in paragraphs (b)(6) and (7) of this section.

(1) For each closed vent system joint, seam, or other connection that is permanently or semi-permanently sealed (e.g., a welded joint between two sections of hard piping or a bolted and gasketed ducting flange), you must meet the requirements specified in paragraphs (a)(1)(i) through (iii) of this section.

(i) Conduct an initial inspection according to the test methods and procedures specified in paragraph (b) of this section to demonstrate that the closed vent system operates with no identifiable emissions within the first 30 calendar days after startup of the affected facility routing emissions through the closed vent system.

(ii) Conduct annual visual inspections for defects that could result in air emissions. Defects include, but are not limited to, visible cracks, holes, or gaps in piping; loose connections; liquid leaks; or broken or missing caps or other closure devices. You must monitor a component or connection using the test methods and procedures in paragraph (b) of this section to demonstrate that it operates with no identifiable emissions following any time the component is repaired or replaced or the connection is unsealed.

(iii) Conduct AVO inspections in accordance with and at the same frequency as specified for fugitive emissions components affected facilities located at the same type of site as specified in § 60.5397b(g). Process unit equipment affected facilities must conduct annual AVO inspections concurrent with the inspections required by paragraph (a)(1)(ii) of this section.

(2) For closed vent system components other than those specified in paragraph (a)(1) of this section, you must meet the requirements of paragraphs (a)(2)(i) through (iv) of this section.

(i) Conduct an initial inspection according to the test methods and procedures specified in paragraph (b) of this section within the first 30 calendar days after startup of the affected facility routing emissions through the closed vent system to demonstrate that the

closed vent system operates with no identifiable emissions.

(ii) Conduct inspections according to the test methods, procedures, and frequencies specified in paragraph (b) of this section to demonstrate that the components or connections operate with no identifiable emissions.

(iii) Conduct annual visual inspections for defects that could result in air emissions. Defects include, but are not limited to, visible cracks, holes, or gaps in ductwork; loose connections; liquid leaks; or broken or missing caps or other closure devices. You must monitor a component or connection using the test methods and procedures in paragraph (b) of this section to demonstrate that it operates with no identifiable emissions following any time the component is repaired or replaced or the connection is unsealed.

(iv) Conduct AVO inspections in accordance with and at the same frequency as specified for fugitive emissions components affected facilities located at the same type of site, as specified in § 60.5397b(g). Process unit equipment affected facilities must conduct annual AVO inspections concurrent with the inspections required by paragraph (a)(2)(iii) of this section.

(3) For each cover, you must meet the requirements of paragraphs (a)(3)(i) through (iv) of this section.

(i) Conduct the inspections specified in paragraphs (a)(3)(ii) through (iv) of this section to identify defects that could result in air emissions and to ensure the cover operates with no identifiable emissions. Defects include, but are not limited to, visible cracks, holes, or gaps in the cover, or between the cover and the separator wall; broken, cracked, or otherwise damaged seals or gaskets on closure devices; and broken or missing hatches, access covers, caps, or other closure devices. In the case where the storage vessel is buried partially or entirely underground, you must inspect only those portions of the cover that extend to or above the ground surface, and those connections that are on such portions of the cover (e.g., fill ports, access hatches, gauge wells, etc.) and can be opened to the atmosphere.

(ii) An initial inspection according to the test methods and procedures specified in paragraph (b) of this section, following installation of the cover to demonstrate that each cover operates with no identifiable emissions.

(iii) Conduct AVO inspections in accordance with and at the same frequency as specified for fugitive emissions components affected facilities located at the same type of site as

specified in § 60.5397b(g). Process unit equipment affected facilities must conduct annual AVO inspections concurrent with the inspections required by paragraph (a)(1)(ii) of this section.

(iv) Inspections according to the test methods, procedures, and schedules specified in paragraph (b) of this section to demonstrate that each cover operates with no identifiable emissions.

(4) For each bypass device, except as provided for in § 60.5411b(a)(4)(ii), you must meet the requirements of paragraph (a)(4)(i) or (ii) of this section.

(i) Set the flow indicator to take a reading at least once every 15 minutes at the inlet to the bypass device that could divert the stream away from the control device and to the atmosphere.

(ii) If the bypass device valve installed at the inlet to the bypass device is secured in the non-diverting position using a car-seal or a lock-and-key type configuration, visually inspect the seal or closure mechanism at least once every month to verify that the valve is maintained in the non-diverting position and the vent stream is not diverted through the bypass device.

(b) *No identifiable emissions test methods and procedures.* If you are required to conduct an inspection of a closed vent system and cover as specified in paragraph (a)(1), (2), or (3) of this section or § 60.5398b(b), you must meet the requirements of paragraphs (b)(1) through (9) of this section. You must meet the requirements of paragraphs (b)(1), (2), (4), and (9) of this section for each self-contained process controller at your process controller affected facility as specified at § 60.5390b(a)(2).

(1) *Initial and periodic inspection.* You must conduct initial and periodic no identifiable emissions inspections as specified in paragraphs (b)(1)(i) through (iii) of this section, as applicable.

(i) You must conduct inspections for no identifiable emissions from your covers and closed vent systems at your well, centrifugal compressor, reciprocating compressor, process controller, pump, or storage vessel affected facility, using the procedures for conducting OGI inspections in § 60.5397b(c)(7). As an alternative you may conduct inspections in accordance with Method 21 of appendix A-7 to this part. Monitoring must be conducted at the same frequency as specified for fugitive emissions components affected facilities located at the same type of site, as specified in § 60.5397b(g).

(ii) For covers and closed vent systems located at onshore natural gas processing plants, OGI inspections for no identifiable emissions must be

conducted initially and bimonthly in accordance with appendix K to this part. As an alternative you must conduct quarterly inspections for no identifiable emissions in accordance with Method 21 of appendix A-7 to this part.

(iii) For your self-contained process controller, you must conduct initial and quarterly inspections for no identifiable emissions using the procedures for conducting OGI inspections in § 60.5397b(c)(7). As an alternative you may conduct quarterly inspections in accordance with Method 21 of appendix A-7 to this part.

(2) *OGI application*. Where OGI is used, the closed vent system, cover, or self-contained process controller is determined to operate with no identifiable emissions if no emissions are imaged during the inspection. Emissions imaged by OGI constitute a deviation of the no identifiable emissions standard until an OGI inspection conducted in accordance with this paragraph (b)(2) of this section determines that the closed vent system, cover, or self-contained process controller, as applicable, operates with no identifiable emissions.

(3) *AVO application*. Where AVO inspections are required, the closed vent system or cover is determined to operate with no identifiable emissions if no emissions are detected by AVO. Emissions detected by AVO constitute a deviation of the no identifiable emissions standard until an AVO inspection determines that the closed vent system or cover operates with no identifiable emissions.

(4) *Method 21 application*. Where Method 21 of appendix A-7 to this part is used for the inspection, the requirements of paragraphs (b)(4)(i) through (vii) of this section apply.

(i) The detection instrument must meet the performance criteria of Method 21 of appendix A-7 to this part, except that the instrument response factor criteria in section 8.1.1 of Method 21 must be for the average composition of the fluid and not for each individual organic compound in the stream.

(ii) You must calibrate the detection instrument before use on each day of its use by the procedures specified in Method 21 of appendix A-7 to this part.

(iii) Calibration gases must be as specified in paragraphs (b)(4)(iii)(A) and (B) of this section.

(A) Zero air (less than 10 parts per million by volume hydrocarbon in air).

(B) A mixture of methane in air at a concentration less than 500 ppmv.

(iv) You may choose to adjust or not adjust the detection instrument readings to account for the background organic

concentration level. If you choose to adjust the instrument readings for the background level, you must determine the background level value according to the procedures in Method 21 of appendix A-7 to this part.

(v) Your detection instrument must meet the performance criteria specified in paragraphs (b)(4)(v)(A) and (B) of this section.

(A) Except as provided in paragraph (b)(4)(v)(B) of this section, the detection instrument must meet the performance criteria of Method 21 of appendix A-7 to this part, except the instrument response factor criteria in section 8.1.1 of Method 21 must be for the average composition of the process fluid, not each individual volatile organic compound in the stream. For process streams that contain nitrogen, air, or other inerts that are not organic hazardous air pollutants or volatile organic compounds, you must calculate the average stream response factor on an inert-free basis.

(B) If no instrument is available that will meet the performance criteria specified in paragraph (b)(4)(v)(A) of this section, you may adjust the instrument readings by multiplying by the average response factor of the process fluid, calculated on an inert-free basis, as described in paragraph (b)(4)(v)(A) of this section.

(vi) You must determine if a potential leak interface operates with no identifiable emissions using the applicable procedure specified in paragraph (b)(4)(vi)(A) or (B) of this section.

(A) If you choose not to adjust the detection instrument readings for the background organic concentration level, then you must directly compare the maximum organic concentration value measured by the detection instrument to the applicable value for the potential leak interface as specified in paragraph (b)(4)(vii) of this section.

(B) If you choose to adjust the detection instrument readings for the background organic concentration level, you must compare the value of the arithmetic difference between the maximum organic concentration value measured by the instrument and the background organic concentration value as determined in paragraph (b)(4)(iv) of this section with the applicable value for the potential leak interface as specified in paragraph (b)(4)(vii) of this section.

(vii) A closed vent system, cover, or self-contained process controller is determined to operate with no identifiable emissions if the organic concentration value determined in paragraph (b)(4)(vi) of this section is less

than 500 ppmv. An organic concentration value determined in paragraph (b)(4)(vi) of this section of greater than or equal to 500 ppmv constitutes a deviation of the no identifiable emissions standard until an inspection conducted in accordance with paragraph (b)(4) of this section determines that the closed vent system, cover, or self-contained process controller, as applicable, operates with no identifiable emissions.

(5) *Repairs*. Whenever emissions or a defect is detected, you must repair the emissions or defect as soon as practicable according to the requirements of paragraphs (b)(5)(i) through (iii) of this section, except as provided in paragraph (b)(6) of this section.

(i) A first attempt at repair must be made no later than 5 calendar days after the emissions or defect is detected.

(ii) Repair must be completed no later than 30 calendar days after the emissions or defect is detected.

(iii) For covers, grease or another substance compatible with the gasket material must be applied to deteriorating or cracked gaskets to improve the seal while awaiting repair.

(6) *Delay of repair*. Delay of repair of a closed vent system or cover for which emissions or defects have been detected is allowed if the repair is technically infeasible without a shutdown, or if you determine that emissions resulting from immediate repair would be greater than the emissions likely to result from delay of repair. You must complete repair of such equipment by the end of the next shutdown.

(7) *Unsafe to inspect requirements*. You may designate any parts of the closed vent system or cover as unsafe to inspect if the requirements of paragraphs (b)(7)(i) and (ii) of this section are met. Unsafe to inspect parts are exempt from the inspection requirements of paragraphs (a)(1) through (3) of this section.

(i) You determine that the equipment is unsafe to inspect because inspecting personnel would be exposed to an imminent or potential danger as a consequence of complying with paragraphs (a)(1), (2), or (3) of this section.

(ii) You have a written plan that requires inspection of the equipment as frequently as practicable during safe-to-inspect times.

(8) *Difficult to inspect requirements*. You may designate any parts of the closed vent system or cover as difficult to inspect if the requirements of paragraphs (b)(8)(i) and (ii) of this section are met. Difficult to inspect parts are exempt from the inspection

requirements of paragraphs (a)(1) through (3) of this section.

(i) You determine that the equipment cannot be inspected without elevating the inspecting personnel more than 2 meters above a support surface.

(ii) You have a written plan that requires inspection of the equipment at least once every 5 years.

(9) *Records and reports.* You must maintain records of all inspection results as specified in § 60.5420b(c)(8) through (10). You must submit the reports as specified in § 60.5420b(b)(11).

§ 60.5417b What are the continuous monitoring requirements for my control devices?

You must meet the requirements of this section to demonstrate continuous compliance for each control device used to meet emission standards for your well, centrifugal compressor, reciprocating compressor, process controller, pump, storage vessel, and process unit equipment affected facilities.

(a) For each control device used to comply with the emission reduction standard in § 60.5377b(b) for well affected facilities, § 60.5380b(a)(1) for centrifugal compressor affected facilities, § 60.5385b(d)(2) for reciprocating compressor affected facilities, § 60.5390b(b)(3) for your process controller affected facility in Alaska, § 60.5393b(b)(1) for your pumps affected facility, § 60.5395b(a)(2) for your storage vessel affected facility, or either § 60.5400b(f) or § 60.5401b(e) for your process equipment affected facility, you must install and operate a continuous parameter monitoring system for each control device as specified in paragraphs (c) through (h) of this section, except as provided for in paragraph (b) of this section. If you install and operate a flare in accordance with § 60.5412b(a)(3), you are exempt from the requirements of paragraph (f) of this section. If you operate an enclosed combustion device or flare using an alternative test method approved under § 60.5412b(d), you must operate the control device as specified in paragraph (i) of this section instead of using the procedures specified in paragraphs (c) through (h) of this section. You must keep records and report in accordance with paragraph (j) of this section.

(b) You are exempt from the monitoring requirements specified in paragraphs (c) through (g) of this section for the control devices listed in paragraphs (b)(1) and (2) of this section.

(1) A boiler or process heater in which all vent streams are introduced with the

primary fuel or are used as the primary fuel.

(2) A boiler or process heater with a design heat input capacity equal to or greater than 44 megawatts.

(c) You must meet the specifications and requirements of paragraphs (c)(1) through (4) of this section.

(1) Except for continuous parameter monitoring systems used to detect the presence of a pilot or combustion flame, each continuous parameter monitoring system must measure data values at least once every hour and record the values for each parameter as required in paragraphs (c)(1)(i) or (ii) of this section. Continuous parameter monitoring systems used to detect the presence of a pilot or combustion flame must record a reading at least once every 5 minutes.

(i) Each measured data value.

(ii) Each block average value for each 1-hour period or shorter periods calculated from all measured data values during each period.

(2) You must prepare a monitoring plan that covers each control device for affected facilities within each company-defined area. The monitoring plan must address the monitoring system design, data collection, and the quality assurance and quality control elements outlined in paragraphs (c)(2)(i) through (v) of this section. You must install, calibrate, operate, and maintain each continuous parameter monitoring system in accordance with the procedures in your monitoring plan. Heat sensing monitoring devices that indicate the continuous ignition of a pilot or combustion flame are exempt from the calibration, quality assurance and quality control requirements of this section.

(i) The performance criteria and design specifications for the monitoring system equipment, including the sample interface, detector signal analyzer, and data acquisition and calculations.

(ii) Sampling interface (*e.g.*, thermocouple) location such that the monitoring system will provide representative measurements.

(iii) Equipment performance checks, system accuracy audits, or other audit procedures.

(iv) Ongoing operation and maintenance procedures in accordance with provisions in § 60.13(b).

(v) Ongoing recordkeeping procedures in accordance with provisions in § 60.7(f).

(3) You must conduct the continuous parameter monitoring system equipment performance checks, system accuracy audits, or other audit procedures specified in the monitoring plan at least once every 12 months.

(4) You must conduct a performance evaluation of each continuous parameter monitoring system in accordance with the monitoring plan. Heat sensing monitoring devices that indicate the continuous ignition of a pilot or combustion flame are exempt from the calibration, quality assurance and quality control requirements of this section.

(d) You must install, calibrate, operate, and maintain a device equipped with a continuous recorder to measure the values of operating parameters appropriate for the control device as specified in paragraphs (d)(1) through (8) of this section, as applicable. Instead of complying with the requirements in paragraphs (d)(1) through (8) of this section, you may install an organic monitoring device equipped with a continuous recorder that measures the concentration level of organic compounds in the exhaust vent stream from the control device to demonstrate compliance with the applicable performance requirement specified in § 60.5412b(a)(1). The monitor must meet the requirements of Performance Specification 8 or 9 of appendix B to this part. You must install, calibrate, and maintain the monitor according to the manufacturer's specifications and the requirements in Performance Specification 8 or 9. You may also request approval from the Administrator to monitor different operating parameters than those specified in paragraphs (d)(1) through (8) of this section in accordance with § 60.13(i).

(1) For an enclosed combustion device that demonstrates during the performance test conducted under § 60.5413b(b) that combustion zone temperature is an accurate indicator of performance, a temperature monitoring device equipped with a continuous recorder. The monitoring device must have a minimum accuracy of ± 1 percent of the temperature being monitored in degrees Celsius, or ± 2.5 °C, whichever value is greater. You must install the temperature sensor at a location representative of the combustion zone temperature. You must also comply with the requirements of paragraphs (d)(8)(i), (iv), and (v) of this section.

(2) For a catalytic vapor incinerator, a temperature monitoring device equipped with a continuous recorder. The device must be capable of monitoring temperature at two locations and have a minimum accuracy of ± 1 percent of the temperature being monitored in degrees Celsius, or ± 2.5 °C, whichever value is greater. You must install one temperature sensor in the vent stream at the nearest feasible point

to the catalyst bed inlet, and you must install a second temperature sensor in the vent stream at the nearest feasible point to the catalyst bed outlet.

(3) For a boiler or process heater, a temperature monitoring device equipped with a continuous recorder. The temperature monitoring device must have a minimum accuracy of ± 1 percent of the temperature being monitored in degrees Celsius, or ± 2.5 °C, whichever value is greater. You must install the temperature sensor at a location representative of the combustion zone temperature.

(4) For a condenser, a temperature monitoring device equipped with a continuous recorder. The temperature monitoring device must have a minimum accuracy of ± 1 percent of the temperature being monitored in degrees Celsius, or ± 2.5 °C, whichever value is greater. You must install the temperature sensor at a location in the exhaust vent stream from the condenser.

(5) For a regenerative-type carbon adsorption system, a continuous monitoring system that meets the specifications in paragraphs (d)(5)(i) and (ii) of this section. You also must monitor the design carbon service life established using a design analysis performed as specified in § 60.5413b(c)(2).

(i) The continuous parameter monitoring system must measure and record the average total regeneration stream mass flow or volumetric flow during each carbon bed regeneration cycle. The flow sensor must have a measurement sensitivity of 5 percent of the flow rate or 10 cubic feet per minute, whichever is greater. You must check the mechanical connections for leakage at least every month, and you must perform a visual inspection at least every 3 months of all components of the flow continuous parameter monitoring system for physical and operational integrity and all electrical connections for oxidation and galvanic corrosion if your flow continuous parameter monitoring system is not equipped with a redundant flow sensor; and

(ii) The continuous parameter monitoring system must measure and record the average carbon bed temperature for the duration of the carbon bed steaming cycle and measure the actual carbon bed temperature after regeneration and within 15 minutes of completing the cooling cycle. The temperature monitoring device must have a minimum accuracy of ± 1 percent of the temperature being monitored in degrees Celsius, or ± 2.5 °C, whichever value is greater.

(6) For a nonregenerative-type carbon adsorption system, you must monitor

the design carbon replacement interval established using a design analysis performed as specified in § 60.5413b(c)(3). The design carbon replacement interval must be based on the total carbon working capacity of the control device and source operating schedule.

(7) For a combustion control device whose model is tested under § 60.5413b(d), continuous monitoring systems as specified in paragraphs (d)(8)(i) through (iv) and (d)(8)(vi) of this section and visible emission observations conducted as specified in paragraph (d)(8)(v) of this section.

(8) For an enclosed combustion device other than those listed in paragraphs (d)(1) through (3) and (7) of this section or for a flare, continuous monitoring systems as specified in paragraphs (d)(8)(i) through (iv) of this section and visible emission observations conducted as specified in paragraph (d)(8)(v) of this section. Additionally, for enclosed combustion devices or flares that are air-assisted or steam-assisted, the continuous monitoring systems specified in paragraph (d)(8)(vi) of this section.

(i) Continuously monitor at least once every five minutes for the presence of a pilot flame or combustion flame using a device (including, but not limited to, a thermocouple, ultraviolet beam sensor, or infrared sensor) capable of detecting that the pilot or combustion flame is present at all times. An alert must be sent to the nearest control room whenever the pilot or combustion flame is unlit. Continuous monitoring systems used for the presence of a pilot flame or combustion flame are not subject to a minimum accuracy requirement beyond being able to detect the presence or absence of a flame and are exempt from the calibration requirements of this section.

(ii) Except as provided in this paragraph (d)(8)(ii) and paragraph (d)(8)(iii) of this section, use one of the following methods to continuously determine the NHV of the inlet gas to the enclosed combustion device or flare at standard conditions. If the only inlet gas stream to the enclosed combustion device or flare is associated gas from a well affected facility, the NHV of the inlet stream is considered to be sufficiently above the minimum required NHV for the inlet gas, and you are not required to conduct the continuous monitoring in this paragraph (d)(8)(ii) of this section or the demonstration in paragraph (d)(8)(iii) of this section.

(A) A calorimeter with a minimum accuracy of ± 2 percent of span.

(B) A gas chromatograph that meets the requirements in paragraphs (d)(8)(ii)(B)(1) through (5) of this section.

(1) You must follow the procedure in Performance Specification 9 of appendix B of this part, except that a single daily mid-level calibration check can be used (rather than triplicate analysis), the multi-point calibration can be conducted quarterly (rather than monthly), and the sampling line temperature must be maintained at a minimum temperature of 60 °C (rather than 120 °C). Calibration gas cylinders must be certified to an accuracy of 2 percent and traceable to National Institute of Standards and Technology (NIST) standards.

(2) You must meet the accuracy requirements in Performance Specification 9 of appendix B of this part.

(3) You must use a calibration gas or multiple gases that includes the compounds that are reasonably expected to be present in the flare gas stream. If multiple calibration gases are necessary to cover all compounds, you must calibrate the instrument on all of the gases. You may only use the compounds used to calibrate the gas chromatograph in the calculation of the vent gas NHV.

(4) In lieu of the calibration gas described in paragraph (d)(8)(ii)(B)(3) of this section, you may use a surrogate calibration gas consisting of hydrogen and C1 through C5 normal hydrocarbons. All of the calibration gases may be combined in one cylinder. If multiple calibration gases are necessary to cover all compounds, you must calibrate the instrument on all of the gases. Use the response factor for the nearest normal hydrocarbon (*i.e.*, n-alkane) in the calibration mixture to quantify unknown components detected in the analysis. Use the response factor for n-pentane to quantify unknown components detected in the analysis that elute after n-pentane.

(5) To determine the NHV of the vent gas, determine the product of the volume fraction of the individual component in the vent gas and the net heating value of that individual component. Sum the products for all components in the vent gas to determine the NHV for the vent gas. For the net heating value of each individual component, use the net heating value at 25 °C and 1 atmosphere.

(C) A mass spectrometer that meets the requirements in paragraphs (d)(8)(ii)(C)(1) through (6) of this section.

(1) You must meet applicable requirements in Performance

Specification 9 of appendix B of this part for continuous monitoring system acceptance including, but not limited to, performing an initial multi-point calibration check at three concentrations following the procedure in Section 10.1. A single daily mid-level calibration check can be used (rather than triplicate analysis), the multi-point calibration

can be conducted quarterly (rather than monthly), and the sampling line temperature must be maintained at a minimum temperature of 60 °C (rather than 120 °C). Calibration gas cylinders must be certified to an accuracy of 2 percent and traceable to NIST standards.

(2) The average instrument calibration error (CE) for each calibration

compound at any calibration concentration must not differ by more than 10 percent from the certified cylinder gas value. The CE for each component in the calibration blend must be calculated using the following equation:

Equation 1 to paragraph (d)(8)(ii)(C)(2)

$$CE = \frac{C_m - C_a}{C_a} \times 100$$

Where:

C_m = Average instrument response (ppm).

C_a = Certified cylinder gas value (ppm).

(3) You must use a calibration gas or multiple gases that includes the compounds that are reasonably expected to be present in the flare gas stream. If multiple calibration gases are necessary to cover all compounds, you must calibrate the instrument on all of the gases. You may only use the compounds used to calibrate the mass spectrometer in the calculation of the vent gas NHV.

(4) In lieu of the calibration gas described in paragraph (d)(8)(ii)(C)(3) of this section, you may use a surrogate calibration gas consisting of hydrogen and C1 through C5 normal hydrocarbons. All of the calibration gases may be combined in one cylinder. If multiple calibration gases are necessary to cover all compounds, you must calibrate the instrument on all of the gases. For unknown gas components that have similar analytical mass fragments to calibration compounds, you may report the unknowns as an increase in the overlapped calibration gas compound. For unknown compounds that produce mass fragments that do not overlap calibration compounds, you may use the response factor for the nearest molecular weight hydrocarbon in the calibration mix to quantify the unknown component. You may use the response factor for n-pentane to quantify any unknown components detected with a higher molecular weight than n-pentane.

(5) You must perform an initial calibration to identify mass fragment overlap and response factors for the target compounds.

(6) To determine the NHV of the vent gas, determine the product of the volume fraction of the individual component in the vent gas and the net heating value of that individual

component. Sum the products for all components in the vent gas to determine the NHV for the vent gas. For the net heating value of each individual component, use the net heating value at 25 °C and 1 atmosphere.

(D) A grab sampling system capable of collecting an evacuated canister sample for subsequent compositional analysis at least once every eight hours. Subsequent compositional analysis of the samples must be performed according to ASTM D1945–14 (R2019) (incorporated by reference, see § 60.17). To determine the NHV of the vent gas, determine the product of the volume fraction of the individual component in the vent gas and the net heating value of that individual component. Sum the products for all components in the vent gas to determine the NHV for the vent gas. For the net heating value of each individual component, use the net heating value at 25 °C and 1 atmosphere.

(iii) For an unassisted or pressure-assisted flare or enclosed combustion device, if you demonstrate according to the methods described in paragraphs (d)(8)(iii)(A) through (F) of this section that the NHV of the inlet gas to the enclosed combustion device or flare consistently exceeds the applicable operating limit specified in § 60.5415b(f)(1)(vii)(B) or (C), continuous monitoring of the NHV is not required, but you must conduct the ongoing sampling in paragraph (d)(8)(iii)(G) of this section. For flares and enclosed combustion devices that use only perimeter assist air and do not use steam assist or premix assist air, if you demonstrate according to the methods described in paragraphs (d)(8)(iii)(A) through (F) of this section that the NHV of the inlet gas to the enclosed combustion device or flare consistently exceeds 300 Btu/scf, continuous monitoring of the NHV is not required, but you must conduct the ongoing sampling in paragraph

(d)(8)(iii)(G) of this section. For an unassisted or pressure-assisted flare or enclosed combustion device, in lieu of conducting the demonstration outlined in paragraphs (d)(8)(iii)(A) through (D) of this section, you may conduct the demonstration outlined in paragraph (d)(8)(iii)(H) of this section, but you must still comply with paragraphs (d)(8)(iii)(E) through (G) of this section.

(A) Continuously monitor or collect a sample of the inlet gas to the enclosed combustion device or flare twice daily to determine the average NHV of the gas stream for 14 consecutive operating days. If you do not continuously monitor the NHV, the minimum time of collection for each individual sample be at least one hour. Consecutive samples must be separated by at least 6 hours. If inlet gas flow is intermittent such that there are not at least 28 samples over the 14 operating day period, you must continue to collect samples of the inlet gas beyond the 14 operating day period until you collect a minimum of 28 samples.

(B) If you collect samples twice per day, count the number of samples where the NHV value is less than 1.2 times the applicable operating limit specified in § 60.5415b(f)(1)(vii)(B), (C), or paragraph (d)(8)(iii) of this section (*i.e.*, values that are less than 240, 300, or 960 Btu/scf, as applicable) during the sample collection period in paragraph (d)(8)(iii)(A) of this section.

(C) If you continuously sample the inlet stream for 14 days, count the number of hourly average NHV values that are less than the applicable operating limit specified in § 60.5415b(f)(1)(vii)(B), § 60.5415b(f)(1)(vii)(C)(1), or paragraph (d)(8)(iii) of this section (*i.e.*, values that are less than 200, 300, or 800 Btu/scf, as applicable), during the sample collection period in paragraph (d)(8)(iii)(A) of this section.

(D) If there are no samples counted under paragraph (d)(8)(iii)(B) of this section or there are no hourly values counted under paragraph (d)(8)(iii)(C) of this section, the gas stream is considered to consistently exceed the applicable NHV operating limit and on-going continuous monitoring is not required.

(E) If process operations are revised that could impact the NHV of the gas sent to the enclosed combustion device or flare, such as the removal or addition of process equipment, and at any time the Administrator requires, re-evaluation of the gas stream must be performed according to paragraphs (d)(8)(iii)(A) through (D) of this section to ensure the gas stream still consistently exceeds the applicable operating limit specified in § 60.5415b(f)(1)(vii)(B), (f)(1)(vii)(C)(1), or paragraph (d)(8)(iii) of this section.

(F) When collecting samples under paragraph (d)(8)(iii)(A) of this section, the owner or operator must account for any sources of inert gases that can be sent to the enclosed combustion device or flare (e.g., streams from compressors in acid gas service, streams from enhanced oil recovery facilities). The report in § 60.5420b(b)(11)(v)(I) and the records of the demonstration in § 60.5420b(c)(11)(vi) must note whether the enclosed combustion device or flare has the potential to receive inert gases, and if so, whether the sampling included periods where the highest percentage of inert gases were sent to the enclosed combustion device or flare. If the introduction of inerts is intermittent and does not occur during the initial demonstration, the introduction of inerts will be considered a revision to process operations that triggers a re-evaluation under paragraph (d)(8)(iii)(E) of this section. If conditions at the site did not allow sampling during periods where the introduction of inert gases was at the highest percentage possible, increasing the percentage of inerts will be considered a revision to process operations that triggers a re-evaluation under paragraph (d)(8)(iii)(E) of this section.

(G) You must collect three samples of the inlet gas to the enclosed combustion device or flare at least once every 5 years. The minimum time of collection for each individual sample must be at least one hour. The samples must be taken during the period with the lowest expected NHV (i.e., the period with the highest percentage of inerts). The first set of periodic samples must be taken, or continuous monitoring commenced, no later than 60 calendar months following the last sample taken under paragraph (d)(8)(iii)(A) of this section.

Subsequent periodic samples must be taken, or continuous monitoring commenced, no later than 60 calendar months following the previous sample. If any sample has an NHV value less than 1.2 times the applicable operating limit specified in § 60.5415b(f)(1)(vii)(B), § 60.5415b(f)(1)(vii)(C), or paragraph (d)(8)(iii) of this section (i.e., values that are less than 240, 360, or 960 Btu/scf, as applicable), you must conduct the monitoring required by paragraph (d)(8)(ii) of this section.

(H) You may request an alternative test method under § 60.5412b(d) to demonstrate that the flare or enclosed combustion device reduces methane and VOC in the gases vented to the device by 95.0 percent by weight or greater. You must use an alternative test method that demonstrates compliance with the combustion efficiency limit; you may not use an alternative test method that demonstrates compliance with NHV_{cz} and NHV_{dil} in lieu of measuring combustion efficiency directly. You must measure data values at the frequency specified in the alternative test method and conduct the quality assurance and quality control requirements outlined in the alternative test method at the frequency outlined in the alternative test method. You must monitor the combustion efficiency of the flare continuously for 14 days. If there are no values of the combustion efficiency measured by the alternative test method that are less than 95.0 percent, the gas stream is considered to consistently exceed the applicable NHV operating limit, and you are not required to continuously monitor the NHV of the inlet gas to the flare or enclosed combustion device.

(iv) Except as noted in paragraphs (d)(8)(iv)(A) through (E) of this section, a continuous parameter monitoring system for measuring the flow of gas to the enclosed combustion device or flare. You may use direct flow meters or other parameter monitoring systems combined with engineering calculations, such as inlet line pressure, line size, and burner nozzle dimensions, to satisfy this requirement. The monitoring instrument must have an accuracy of ± 10 percent or better at the maximum expected flow rate.

(A) Pressure-assisted flares and pressure-assisted enclosed combustion devices are not required to have a continuous parameter monitoring system for measuring the inlet flow of gas to the device if you install, calibrate, maintain, and operate a backpressure regulator valve calibrated to open at the minimum pressure set point corresponding to the minimum inlet gas

flow rate. The set point must be consistent with manufacturer specifications for minimum flow or pressure and must be supported by an engineering evaluation. At least annually, you must confirm that the backpressure regulator valve set point is correct and consistent with the engineering evaluation and manufacturer specifications and that the valve fully closes when not in the open position.

(B) Unassisted flares are not required to have a continuous parameter monitoring system for measuring the inlet flow of gas to the device if you meet the conditions in paragraphs (d)(8)(iv)(B)(1) and (2) of this section.

(1) You must demonstrate, based on the maximum potential pressure of units manifolded to the flare and applicable engineering calculations for the manifolded closed vent system, that the maximum flow rate to the flare cannot cause the flare tip velocity to exceed 18.3 meter/second (60 feet/second). If there are changes to the process or control device that can be reasonably expected to impact the maximum flow rate to the flare, you must conduct a new demonstration to determine whether the maximum flow rate to the flare is less than 18.3 meter/second (60 feet/second).

(2) You must install, calibrate, maintain, and operate a backpressure regulator valve calibrated to open at the minimum pressure set point corresponding to the minimum inlet gas flow rate. The set point must be consistent with manufacturer specifications for minimum flow or pressure and must be supported by an engineering evaluation. At least annually, you must confirm that the backpressure regulator valve set point is correct and consistent with the engineering evaluation and manufacturer specifications and that the valve fully closes when not in the open position.

(C) Unassisted enclosed combustion devices are not required to have a continuous parameter monitoring system for measuring the inlet flow of gas to the device if you meet the conditions in paragraphs (d)(8)(iv)(C)(1) and (2) of this section.

(1) You must demonstrate, based on the maximum potential pressure of units manifolded to the enclosed combustion device and applicable engineering calculations for the manifolded closed vent system, that the maximum flow rate to the enclosed combustion device cannot cause the maximum inlet flow rate established in accordance with paragraph (f)(1) of this section to be exceeded. If there are

changes to the process or control device that can be reasonably expected to impact the maximum flow rate to the enclosed combustion device, you must conduct a new demonstration to determine whether the maximum flow rate to the enclosed combustor is less than the maximum inlet flow rate established in accordance with paragraph (f)(1) of this section.

(2) You must install, calibrate, maintain, and operate a backpressure regulator valve calibrated to open at the minimum pressure set point corresponding to the minimum inlet gas flow rate. The set point must be consistent with manufacturer specifications for minimum flow or pressure and must be supported by an engineering evaluation. At least annually, you must confirm that the backpressure regulator valve set point is correct and consistent with the engineering evaluation and manufacturer specifications and that the valve fully closes when not in the open position.

(D) Air-assisted flares or enclosed combustion devices that use only perimeter assist air and have no assist steam or pre-mix assist air are not required to have a continuous parameter monitoring system for measuring the inlet flow of gas to the device or the flow of assist air if you meet the conditions in paragraphs (d)(8)(iv)(D)(1) and (2) of this section. For these flares and enclosed combustion devices, NHV_{cz} is assumed to be equal to the vent gas NHV .

(1) You must install, calibrate, maintain, and operate a backpressure regulator valve calibrated to open at the minimum pressure set point corresponding to the minimum inlet gas flow rate. The set point must be consistent with manufacturer specifications for minimum flow or pressure and must be supported by an engineering evaluation. At least annually, you must confirm that the backpressure regulator valve set point is correct and consistent with the engineering evaluation and manufacturer specifications and that the valve fully closes when not in the open position.

(2) You must demonstrate, based on the maximum flow rate of perimeter assist air to the enclosed combustion device or flare and applicable engineering calculations, that the NHV_{dil} can never be less than the minimum required NHV_{dil} . The demonstration must clearly document why the maximum flow rate of perimeter assist air will never exceed the rate used in the demonstration. You must use the minimum flow rate of vent gas allowed

by your backpressure regulator valve and the minimum expected value of the NHV of the inlet gas to the enclosed combustion device or flare based on previous sampling results or process knowledge of the streams sent to the enclosed combustion device or flare in your demonstration. You must update this demonstration if there are changes to the backpressure regulator valve, the backpressure regulator valve set point, or the maximum flow rate of perimeter assist air. You must also update this demonstration if any sampling results of the NHV of the inlet gas to the enclosed combustion device or flare under paragraphs (d)(8)(ii) or (iii) of this section are lower than the NHV vent gas value used in your demonstration.

(E) Air-assisted flares or enclosed combustion devices that use only pre-mix assist air and have no assist steam or perimeter assist air are not required to have a continuous parameter monitoring system for measuring the inlet flow of gas to the device or the flow of assist air if you meet the conditions in paragraphs (d)(8)(iv)(E)(1) and (2) of this section.

(1) You must install, calibrate, maintain, and operate a backpressure regulator valve calibrated to open at the minimum pressure set point corresponding to the minimum inlet gas flow rate. The set point must be consistent with manufacturer specifications for minimum flow or pressure and must be supported by an engineering evaluation. At least annually, you must confirm that the backpressure regulator valve set point is correct and consistent with the engineering evaluation and manufacturer specifications and that the valve fully closes when not in the open position.

(2) You must demonstrate, based on the maximum flow rate of pre-mix assist air to the enclosed combustion device or flare and applicable engineering calculations, that the NHV_{cz} will never be less than the minimum required NHV_{cz} . The demonstration must clearly document why the maximum flow rate of pre-mix assist air will never exceed the rate used in the demonstration. You must use the minimum flow rate of vent gas allowed by your backpressure regulator valve in and the minimum expected value of the NHV of the inlet gas to the enclosed combustion device or flare based on previous sampling results or process knowledge of the streams sent to the enclosed combustion device or flare in your demonstration. You must update this demonstration if there are changes to the backpressure regulator valve, the backpressure regulator valve set point, or the

maximum flow rate of pre-mix assist air. You must also update this demonstration if any sampling results of the NHV of the inlet gas to the enclosed combustion device or flare under paragraphs (d)(8)(ii) or (iii) of this section are lower than the NHV vent gas value used in your demonstration.

(v) Conduct inspections monthly and at other times as requested by the Administrator to monitor for visible emissions from the combustion device using section 11 of Method 22 of appendix A of this part or conduct visible emissions monitoring according to paragraph (h) of this section. The observation period shall be 15 minutes or once the amount of time visible emissions is present has exceeded 1 minute. Devices must be operated with no visible emissions, except for periods not to exceed a total of 1 minute during any 15-minute period.

(vi) If you use a flare or enclosed combustion device that is air-assisted or steam-assisted, you must also meet the following requirements.

(A) Except as allowed by paragraph (d)(8)(iv)(E) of this section, you must monitor and calculate NHV_{cz} as specified in § 63.670(m) of this chapter. Additionally, for flares and enclosed combustion devices that use only perimeter assist air and do not use steam assist or pre-mix assist air, the NHV_{cz} is equal to the vent gas NHV . When NHV_{cz} is equal to the vent gas NHV , you are not required to continuously monitor NHV_{cz} if you meet the requirements in paragraph (d)(8)(iii) of this section.

(B) Except as allowed by paragraph (d)(8)(iv)(D) of this section, for each flare using perimeter assist air, you must also monitor and calculate NHV_{dil} as specified in § 63.670(n) of this chapter. If the only assist air provided to the flare or enclosed combustion control device is perimeter assist air intentionally entrained in lower and/or upper steam at the flare tip and the effective diameter is 9 inches or greater, you are only required to comply with the NHV_{cz} limit specified in paragraph (f)(8)(vi)(A) of this section.

(C) Except as allowed by paragraph (d)(8)(iv) of this section, you must monitor the flare vent gas and assist gas as specified in § 63.670(i) of this chapter.

(D) You must determine the flare vent gas net heating value as specified in § 63.670(l) of this chapter using one of the methods specified in paragraph (d)(8)(ii) of this section. Where the phrase "petroleum refinery" is used, for purposes of this subpart, it will refer to flares controlling an affected facility under this subpart. If you are not

required to continuously monitor the NHV of the inlet gas because you have demonstrated that it consistently exceeds the applicable operating limit as provided in paragraph (d)(8)(iii) of this section, you must use the lowest net heating value measured in the sampling program in paragraph (d)(8)(iii) of this section for the calculations performed in paragraphs (d)(8)(vi)(A) and (B). You must update this value if a subsequent sampling result of the NHV of the inlet gas to the enclosed combustion device or flare under paragraph (d)(8)(iii) of this section is lower than the NHV vent gas value used in your calculations.

(e) Calculate the value of the applicable monitored parameter in accordance with paragraphs (e)(1) through (5) of this section.

(1) You must calculate the daily average value for condenser outlet temperature for each operating day, using the data recorded by the monitoring system. If the emissions unit operation is continuous, the operating day is a 24-hour period. If the emissions unit operation is not continuous, the operating day is the total number of hours of control device operation per 24-hour period. Valid data points must be available for 75 percent of the operating hours in an operating day to compute the daily average.

(2) You must use the 5-minute readings from the heat sensing devices to assess the presence of a pilot or combustion flame.

(3) You must use the regeneration cycle time (*i.e.*, duration of the carbon bed steaming cycle) for each regenerative-type carbon adsorption system to calculate the average parameter to compare with the maximum steam mass flow or volumetric flow during each carbon bed regeneration cycle and the maximum carbon bed temperature during the steaming cycle. The carbon bed temperature after the regeneration cycle should not be averaged; you must use the carbon bed temperature measured within 15 minutes of completing the cooling cycle to compare with the minimum carbon bed temperature after the regeneration cycle.

(4) You must use 15-minute blocks to calculate NHV_{cz} and NHV_{dii} .

(5) For all operating parameters other than those described in paragraphs (e)(1) through (4) of this section, you must calculate the 3-hour rolling average of each monitored parameter. For each operating hour, calculate the hourly value of the operating parameter from your continuous monitoring system. Average the three most recent hours of data to determine the 3-hour average. Determine the 3-hour rolling

average by recalculating the 3-hour average each hour.

(f) For each operating parameter monitor installed in accordance with the requirements of paragraph (d) of this section, you must comply with paragraph (f)(1) of this section for all control devices. When condensers are installed, you must also comply with paragraph (f)(2) of this section.

(1) You must establish a minimum operating parameter value or a maximum operating parameter value, as appropriate for the control device, to define the conditions at which the control device must be operated to continuously achieve the applicable performance requirements of § 60.5412b(a)(1) or (2). You must establish each minimum or maximum operating parameter value as specified in paragraphs (f)(1)(i) through (iv) of this section.

(i) If you conduct performance tests in accordance with the requirements of § 60.5413b(b) to demonstrate that the control device achieves the applicable performance requirements specified in § 60.5412b(a)(1) or (2), then you must establish the minimum operating parameter value or the maximum operating parameter value based on values measured during the performance test and supplemented, as necessary, by a condenser or carbon adsorption system design analysis or control device manufacturer recommendations or a combination of both. If you operate an enclosed combustion device, you must establish the maximum inlet flow rate based on values measured during the performance test and you may establish the minimum inlet flow rate based on control device manufacturer recommendations.

(ii) If you use a condenser or carbon adsorption system design analysis in accordance with the requirements of § 60.5413b(c) to demonstrate that the control device achieves the applicable performance requirements specified in § 60.5412b(a)(2), then you must establish the minimum operating parameter value or the maximum operating parameter value based on the design analysis and supplemented, as necessary, by the manufacturer's recommendations.

(iii) If you operate a control device where the performance test requirement was met under § 60.5413b(d) to demonstrate that the control device achieves the applicable performance requirements specified in § 60.5412b(a)(1), then your control device inlet gas flow rate must be equal to or greater than the minimum inlet gas flow rate and equal to or less than the

maximum inlet gas flow rate determined by the manufacturer.

(iv) If you operate an enclosed combustion device where the combustion zone temperature is not an indicator of destruction efficiency or a control device where the performance test requirement was met under § 60.5413b(d), you must maintain the NHV of the gas sent to the enclosed combustion device, the NHV_{cz} , and the NHV_{dii} above the applicable limits specified in paragraphs § 60.5412b(a)(1)(iv)(A) through (D).

(2) If you use a condenser as specified in paragraph (d)(1)(v) of this section, you must establish a condenser performance curve showing the relationship between condenser outlet temperature and condenser control efficiency, according to the requirements of paragraphs (f)(2)(i) and (ii) of this section.

(i) If you conduct a performance test in accordance with the requirements of § 60.5413b(b) to demonstrate that the condenser achieves the applicable performance requirements of § 60.5412b(a)(2), then the condenser performance curve must be based on values measured during the performance test and supplemented as necessary by control device design analysis, or control device manufacturer's recommendations, or a combination or both.

(ii) If you use a control device design analysis in accordance with the requirements of § 60.5413b(c)(1) to demonstrate that the condenser achieves the applicable performance requirements specified in § 60.5412b(a)(2), then the condenser performance curve must be based on the condenser design analysis and supplemented, as necessary, by the control device manufacturer's recommendations.

(g) A deviation for a control device is determined to have occurred when the monitoring data or lack of monitoring data result in any one of the criteria specified in paragraphs (g)(1) through (7) of this section being met. If you monitor multiple operating parameters for the same control device during the same operating day and more than one of these operating parameters meets a deviation criterion specified in paragraphs (g)(1) through (7) of this section, then a single excursion is determined to have occurred for the control device for that operating day.

(1) A deviation occurs when the average value of a monitored operating parameter determined in accordance with paragraph (e) of this section is less than the minimum operating parameter limit (and, if applicable, greater than the

maximum operating parameter limit) established in paragraph (f)(1) of this section; for flares, when the average value of a monitored operating parameter determined in accordance with paragraph (e) of this section is above the limits specified in § 60.5415b(f)(1)(vii)(B); or when the heat sensing device indicates that there is no pilot or combustion flame present for any time period. If you use a backpressure regulator valve to maintain the inlet gas flow to an enclosed combustion device or flare above the minimum value, a deviation occurs if the annual inspection finds that the backpressure regulator valve set point is not set correctly or indicates that the backpressure regulator valve does not fully close when not in the open position.

(2) If you are subject to § 60.5412b(a)(2), a deviation occurs when the 365-day average condenser efficiency calculated according to the requirements specified in § 60.5415b(f)(1)(ix)(D) is less than 95.0 percent.

(3) If you are subject to § 60.5412b(a)(2) and you have less than 365 days of data, a deviation occurs when the average condenser efficiency calculated according to the procedures specified in § 60.5415b(f)(1)(ix)(D)(1) or (2) is less than 95.0 percent.

(4) A deviation occurs when the monitoring data are not available for at least 75 percent of the operating hours in a day.

(5) If the closed vent system contains one or more bypass devices that could be used to divert all or a portion of the gases, vapors, or fumes from entering the control device, a deviation occurs when the requirements of paragraph (g)(5)(i) or (ii) of this section are met.

(i) For each bypass line subject to § 60.5411b(a)(4)(i)(A), the flow indicator indicates that flow has been detected and that the stream has been diverted away from the control device to the atmosphere.

(ii) For each bypass line subject to § 60.5411b(a)(4)(i)(B), if the seal or closure mechanism has been broken, the bypass line valve position has changed, the key for the lock-and-key type lock has been checked out, or the car-seal has broken.

(6) For a combustion control device whose model is tested under § 60.5413b(d), a deviation occurs when the conditions of paragraph (g)(4), (5), or (6)(i) through (vi) of this section are met.

(i) The hourly inlet gas flow rate is less than the minimum inlet gas flow rate or greater than the maximum inlet gas flow rate determined by the manufacturer. If you use a backpressure

regulator valve to maintain the inlet gas flow above the minimum value, a deviation occurs if the annual inspection finds that the backpressure regulator valve set point is not set correctly or indicates that the backpressure regulator valve does not fully close when not in the open position.

(ii) Results of the monthly visible emissions test conducted under § 60.5413b(e)(3) or monitoring under paragraph (h) of this section indicate visible emissions exceed 1 minute in any 15-minute period.

(iii) There is no indication of the presence of a pilot or combustion flame for any 5-minute time period.

(iv) The control device is not maintained in a leak free condition.

(v) The control device is not operated in accordance with the manufacturer's written operating instructions, procedures and maintenance schedule.

(vi) The NHV of the vent gas, the NHV_{cz} , or the NHV_{dil} is below the applicable limit specified in § 60.5412b(a)(1)(iv).

(7) For an enclosed combustion device or flare subject to paragraph (d)(8) of this section, a deviation occurs when any of the conditions described by paragraphs (g)(1), (4) or (5) of this section are met or when the results of the visible emissions monitoring conducted under paragraph (d)(8)(v) or (h) of this section exceed 1 minute in any 15-minute period.

(h) For enclosed combustion devices and flares, in lieu of conducting a visible emissions observation using Method 22 of appendix A-7 to this part, you may use a video surveillance camera to continuously monitor and record the flare flame according to the requirements in paragraphs (h)(1) through (6) of this section.

(1) You must provide real-time high-definition video surveillance camera output (*i.e.*, at least 720p) at a frame rate of at least 15 frames per second to the control room or other continuously manned location where the camera images may be viewed at the same resolution at any time.

(2) You must record at least one frame every 15 seconds with date and time stamp.

(3) The camera must be located at a reasonable distance above the flare flame at an angle suitable for visual emissions observations. The position of the camera should be such that the sun is not in the field of view.

(4) The camera must be located no more than 400 m (0.25 miles) from the emission source.

(5) Operators must look at the video feed at least once daily for an

observation period of at least 1 minute to determine if visible emissions are present. If visible emissions are present during a daily observation, the operator must observe the video feed for 15 minutes or until the amount of time visible emissions is present has exceeded 1 minute, whichever time period is less.

(6) Enclosed combustion devices and flares must be operated with no visible emissions, except for periods not to exceed a total of 1 minute during any 15-minute period.

(i) If you use an enclosed combustion device or flare using an alternative test method approved under § 60.5412b(d), you must comply with paragraphs (i)(1) through (6) of this section.

(1) You must measure data values at the frequency specified in the alternative test method.

(2) You must prepare a monitoring plan that covers each control device for affected facilities within each company-defined area. The monitoring plan must address the monitoring system design, data collection, and the quality assurance and quality control elements outlined in the alternative test method and in paragraphs (i)(2)(i) through (iii) of this section. You must operate and maintain each monitoring system in accordance with the procedures in your monitoring plan.

(i) The performance criteria and design specifications for the monitoring system equipment.

(ii) Location of monitoring system in relation to the monitored control device.

(iii) Ongoing reporting and recordkeeping procedures.

(3) You must conduct the quality assurance and quality control requirements outlined in the alternative test method at the frequency outlined in the alternative test method.

(4) If required by § 5412b(d)(4), you must conduct the inspections required by paragraph (d)(8)(v) of this section.

(5) If required by § 5412b(d)(5), you must install the pilot or combustion flame monitoring system required by paragraph (d)(8)(i) of this section.

(6) A deviation for the control device is determined to have occurred when the monitoring data or lack of monitoring data result in any one of the criteria specified in paragraphs (i)(6)(i) through (v) of this section being met.

(i) A deviation occurs if the combustion efficiency is less than 95.0 percent, the combustion zone NHV is less than 270 Btu/scf, or the NHV dilution parameter is less than 22 Btu/sqft.

(ii) A deviation occurs when the monitoring data are not available for at

least 75 percent of the operating hours in a day.

(iii) A deviation occurs when any of the conditions described by paragraph (g)(5) of this section are met.

(iv) If required by paragraph (i)(4) of this section to conduct visible emissions inspections, a deviation occurs when the results of the visible emissions monitoring conducted under paragraph (d)(8)(v) or (h) of this section exceeds 1 minute in any 15-minute period.

(v) If required by paragraph (i)(5) of this section to install a pilot or combustion flame monitoring system, a deviation occurs when there is no indication of the presence of a pilot or combustion flame for any 5-minute period.

(j) You must submit annual reports for control devices as required in § 60.5420b(b)(1) and (11). You must maintain records as specified in § 60.5420b(c)(1).

§ 60.5420b What are my notification, reporting, and recordkeeping requirements?

(a) *Notifications.* You must submit notifications according to paragraphs (a)(1) and (2) of this section if you own or operate one or more of the affected facilities specified in § 60.5365b that was constructed, modified, or reconstructed during the reporting period. You must submit the notification in paragraph (a)(3) of this section if you use an alternative standard for fugitive emissions components in accordance with § 60.5399b. You must submit the notification in paragraph (a)(4) of this section if you undertake well closure activities as specified in § 60.5397b(l).

(1) If you own or operate a process unit equipment affected facility located at an onshore natural gas processing plant, or a sweetening unit, you must submit the notifications required in §§ 60.7(a)(1), (3), and (4) and 60.15(d). If you own or operate a well, centrifugal compressor, reciprocating compressor, process controller, pump, storage vessel, collection of fugitive emissions components at a well site, or collection of fugitive emissions components at a compressor station affected facility, you are not required to submit the notifications required in §§ 60.7(a)(1), (3), and (4) and 60.15(d).

(2) If you own or operate a well affected facility, you must notify the Administrator no later than 2 days prior to the commencement of each well completion operation listing the anticipated date of the well completion operation. The notification shall include contact information for the owner or operator; the United States Well

Number; the latitude and longitude coordinates for each well in decimal degrees to an accuracy and precision of five (5) decimals of a degree using the North American Datum of 1983; and the planned date of the beginning of flowback. You may submit the notification in writing or in electronic format. If you are subject to state regulations that require advance notification of well completions and you have met those notification requirements, then you are considered to have met the advance notification requirements of this paragraph.

(3) An owner or operator electing to comply with the provisions of § 60.5399b for fugitive emissions components shall notify the Administrator of the alternative fugitive emissions standard selected within the annual report, as specified in paragraph (b)(9)(iii) of this section.

(4) An owner or operator who commences well closure activities must submit the following notices to the Administrator according to the schedule in paragraph (a)(4)(i) and (ii) of this section. The notification shall include contact information for the owner or operator; the United States Well Number; the latitude and longitude coordinates for each well at the well site in decimal degrees to an accuracy and precision of five (5) decimals of a degree using the North American Datum of 1983. You must submit notifications in portable document format (PDF) following the procedures specified in paragraph (d) of this section.

(i) You must submit a well closure plan to the Administrator within 30 days of the cessation of production from all wells located at the well site.

(ii) You must submit a notification of the intent to close a well site 60 days before you begin well closure activities.

(b) *Reporting requirements.* You must submit annual reports containing the information specified in paragraphs (b)(1) through (14) of this section following the procedure specified in paragraph (b)(15) of this section. You must submit performance test reports as specified in paragraph (b)(12) or (13) of this section, if applicable. The initial annual report is due no later than 90 days after the end of the initial compliance period as determined according to § 60.5410b. Subsequent annual reports are due no later than the same date each year as the initial annual report. If you own or operate more than one affected facility, you may submit one report for multiple affected facilities provided the report contains all of the information required as specified in paragraphs (b)(1) through (14) of this section. Annual reports may coincide

with title V reports as long as all the required elements of the annual report are included. You may arrange with the Administrator a common schedule on which reports required by this part may be submitted as long as the schedule does not extend the reporting period. You must submit the information in paragraph (b)(1)(v) of this section, as applicable, for your well affected facility which undergoes a change of ownership during the reporting period, regardless of whether reporting under paragraphs (b)(2) through (4) of this section is required for the well affected facility.

(1) The general information specified in paragraphs (b)(1)(i) through (v) of this section is required for all reports.

(i) The company name, facility site name associated with the affected facility, U.S. Well ID or U.S. Well ID associated with the affected facility, if applicable, and address of the affected facility. If an address is not available for the site, include a description of the site location and provide the latitude and longitude coordinates of the site in decimal degrees to an accuracy and precision of five (5) decimals of a degree using the North American Datum of 1983.

(ii) An identification of each affected facility being included in the annual report.

(iii) Beginning and ending dates of the reporting period.

(iv) A certification by a certifying official of truth, accuracy, and completeness. This certification shall state that, based on information and belief formed after reasonable inquiry, the statements and information in the document are true, accurate, and complete. If your report is submitted via CEDRI, the certifier's electronic signature during the submission process replaces the requirement in this paragraph (b)(1)(iv).

(v) Identification of each well affected facility for which ownership changed due to sale or transfer of ownership including the United States Well Number; the latitude and longitude coordinates of the well affected facility in decimal degrees to an accuracy and precision of five (5) decimals of a degree using the North American Datum of 1983; and the information in paragraph (b)(1)(v)(A) or (B) of this section, as applicable.

(A) The name and contact information, including the phone number, email address, and mailing address, of the owner or operator to which you sold or transferred ownership of the well affected facility identified in paragraph (b)(v) of this section.

(B) The name and contact information, including the phone number, email address, and mailing address, of the owner or operator from whom you acquired the well affected facility identified in paragraph (b)(v) of this section.

(2) For each well affected facility that is subject to § 60.5375b(a) or (f), the records of each well completion operation conducted during the reporting period, including the information specified in paragraphs (b)(2)(i) through (xiv) of this section, if applicable. In lieu of submitting the records specified in paragraphs (b)(2)(i) through (xiv) of this section, the owner or operator may submit a list of each well completion with hydraulic fracturing completed during the reporting period, and the digital photograph required by paragraph (c)(1)(v) of this section for each well completion. For each well affected facility that routes all flowback entirely through one or more production separators, only the records specified in paragraphs (b)(2)(i) through (iv) and (vi) of this section are required to be reported. For periods where salable gas is unable to be separated, the records specified in paragraphs (b)(2)(iv) and (viii) through (xii) of this section must also be reported, as applicable. For each well affected facility that is subject to § 60.5375b(g), the record specified in paragraph (b)(2)(xv) of this section is required to be reported. For each well affected facility which makes a claim that the exemption in § 60.5375b(h) was met, the records specified in paragraph (b)(2)(i) through (iv) and (b)(2)(xvi) of this section are required to be reported.

(i) Well Completion ID.

(ii) Latitude and longitude of the well in decimal degrees to an accuracy and precision of five (5) decimals of a degree using North American Datum of 1983.

(iii) U.S. Well ID.

(iv) The date and time of the onset of flowback following hydraulic fracturing or refracturing or identification that the well immediately starts production.

(v) The date and time of each attempt to direct flowback to a separator as required in § 60.5375b(a)(1)(ii).

(vi) The date and time that the well was shut in and the flowback equipment was permanently disconnected, or the startup of production.

(vii) The duration (in hours) of flowback.

(viii) The duration (in hours) of recovery and disposition of recovery (*i.e.*, routed to the gas flow line or collection system, re-injected into the well or another well, used as an onsite fuel source, or used for another useful

purpose that a purchased fuel or raw material would serve).

(ix) The duration (in hours) of combustion.

(x) The duration (in hours) of venting.

(xi) The specific reasons for venting in lieu of capture or combustion.

(xii) For any deviations recorded as specified in paragraph (c)(1)(ii) of this section, the date and time the deviation began, the duration of the deviation in hours, and a description of the deviation.

(xiii) For each well affected facility subject to § 60.5375b(f), a record of the well type (*i.e.*, wildcat well, delineation well, or low pressure well (as defined § 60.5430b)) and supporting inputs and calculations, if applicable.

(xiv) For each well affected facility for which you claim an exception under § 60.5375b(a)(2), the specific exception claimed and reasons why the well meets the claimed exception.

(xv) For each well affected facility with less than 300 scf of gas per stock tank barrel of oil produced, the supporting analysis that was performed in order to make that claim, including but not limited to, GOR values for established leases and data from wells in the same basin and field.

(xvi) For each well affected facility which meets the exemption in § 60.5375b(h), a statement that the well completion operation requirements of § 60.5375b(a)(1) through (3) were met.

(3) For each well affected facility that is subject to § 60.5376b(a)(1) or (2), your annual report is required to include the information specified in paragraphs (b)(3)(i) and (ii) of this section, as applicable.

(i) For each well affected facility where all gas well liquids unloading operations comply with § 60.5376b(a)(1), your annual report must include the information specified in paragraphs (b)(3)(i)(A) through (C) of this section, as applicable.

(A) Identification of each well affected facility (U.S. Well ID or U.S. Well ID associated with the well affected facility) that conducts a gas well liquid unloading operation during the reporting period using a method that does not vent to the atmosphere and the technology or technique used. If more than one non-venting technology or technique is used, you must identify all of the differing non-venting liquids unloading methods used during the reporting period.

(B) Number of gas well liquids unloading operations conducted during the year where the well affected facility identified in (b)(3)(i)(A) had unplanned venting to the atmosphere and best management practices were conducted

according to your best management practice plan, as required by § 60.5376b(c). If no venting events occurred, the number would be zero. Other reported information required to be submitted where unplanned venting occurs is specified in paragraphs (b)(3)(i)(B)(1) and (2) of this section.

(1) Log of best management practice plan steps used during the unplanned venting to minimize emissions to the maximum extent possible.

(2) The number of liquids unloading events during the year where deviations from your best management practice plan occurred, the date and time the deviation began, the duration of the deviation in hours, documentation of why best management practice plan steps were not followed, and what steps, in lieu of your best management practice plan steps, were followed to minimize emissions to the maximum extent possible.

(C) The number of liquids unloading events where unplanned emissions are vented to the atmosphere during a gas well liquids unloading operation where you complied with best management practices to minimize emissions to the maximum extent possible.

(ii) For each well affected facility where all gas well liquids unloading operations comply with § 60.5376b(b) and (c) best management practices, your annual report must include the information specified in paragraphs (b)(3)(ii)(A) through (E) of this section.

(A) Identification of each well affected facility that conducts a gas well liquids unloading during the reporting period.

(B) Number of liquids unloading events conducted during the reporting period.

(C) Log of best management practice plan steps used during the reporting period to minimize emissions to the maximum extent possible.

(D) The number of liquids unloading events during the year that best management practices were conducted according to your best management practice plan.

(E) The number of liquids unloading events during the year where deviations from your best management practice plan occurred, the date and time the deviation began, the duration of the deviation in hours, documentation of why best management practice plan steps were not followed, and what steps, in lieu of your best management practice plan steps, were followed to minimize emissions to the maximum extent possible.

(4) For each associated gas well subject to § 60.5377b, your annual report is required to include the applicable information specified in

paragraphs (b)(4)(i) through (vi) of this section, as applicable.

(i) For each associated gas well that complies with § 60.5377b(a)(1), (2), (3), or (4) your annual report is required to include the information specified in paragraphs (b)(4)(i)(A) and (B) of this section.

(A) An identification of each associated gas well constructed, modified, or reconstructed during the reporting period that complies with § 60.5377b(a)(1), (2), (3), or (4).

(B) The information specified in paragraphs (b)(2)(i)(B)(1) through (3) of this section for each incident when the associated gas was temporarily routed to a flare or control device in accordance with § 60.5377b(d)

(1) The reason in § 60.5377b(d)(1), (2), (3), or (4) for each incident.

(2) The start date and time of each incident of routing associated gas to the flare or control device, along with the total duration in hours of each incident.

(3) Documentation that all CVS requirements specified in § 60.5411b(a) and (c) and all applicable flare or control device requirements specified in § 60.5412b were met during each period when the associated gas is routed to the flare or control device.

(ii) For all instances where you temporarily vent the associated gas in accordance with § 60.5377b(e), you must report the information specified in paragraphs (b)(4)(ii)(A) through (D) of this section. This information is required to be reported if you are routinely complying with § 60.5377b(a) or § 60.5377b(f) or temporarily complying with § 60.5377b(d). In addition to this information for each incident, you must report the cumulative duration in hours of venting incidents and the cumulative VOC and methane emissions in pounds for all incidents in the calendar year.

(A) The reason in § 60.5377b(e)(1), (2), or (3) for each incident.

(B) The start date and time of each incident of venting the associated gas, along with the total duration in hours of each incident.

(C) The VOC and methane emissions in pounds that were emitted during each incident.

(D) The total duration of venting for all incidents in the year, along with the cumulative VOC and methane emissions in pounds that were emitted.

(iii) For each associated gas well that complies with the requirements of § 60.5377b(f) your annual report must include the information specified in paragraphs (b)(4)(iii)(A) through (E) of this section. The information in paragraphs (b)(4)(iii)(A) and (B) of this

section is only required in the initial annual report.

(A) An identification of each associated gas well that commenced construction between May 7, 2024 and May 7, 2026. This identification must include the certification of why it is infeasible to comply with § 60.5377b(a)(1), (2), (3), or (4) in accordance with § 60.5377b(g).

(B) An identification of each associated gas well that commenced construction between December 6, 2022, and May 7, 2024. This identification must include the certification of why it is infeasible to comply with § 60.5377b(a)(1), (2), (3), or (4) in accordance with § 60.5377b(g).

(C) An identification of each associated gas well modified or reconstructed during the reporting period that complies by routing the gas to a control device that reduces VOC and methane emissions by at least 95.0 percent. This identification must include the certification of why it is infeasible to comply with § 60.5377b(a)(1), (2), (3), or (4) in accordance with § 60.5377b(g).

(D) For each associated gas well that was constructed, modified or reconstructed in a previous reporting period that complies by routing the gas to a control device that reduces VOC and methane emissions by at least 95.0 percent, a re-certification of why it is infeasible to comply with § 60.5377b(a)(1), (2), (3), or (4) in accordance with § 60.5377b(g).

(E) The information specified in paragraphs (b)(11)(i) through (iv) of this section.

(iv) If you comply with § 60.5377b(f) with a control device, identification of the associated gas well using the control device and the information in paragraph (b)(11)(v) of this section.

(v) If you comply with an alternative GHG and VOC standard under § 60.5398b, in lieu of the information specified in paragraphs (b)(11)(i) and (ii) of this section, you must provide the information specified in § 60.5424b.

(vi) For each deviation recorded as specified in paragraph (c)(3)(v) of this section, the date and time the deviation began, the duration of the deviation in hours, and a description of the deviation. If no deviations occurred during the reporting period, you must include a statement that no deviations occurred during the reporting period.

(5) For each wet seal centrifugal compressor affected facility, the information specified in paragraphs (b)(5)(i) through (v) of this section. For each self-contained wet seal centrifugal compressor, Alaska North Slope centrifugal compressor equipped with

sour seal oil separator and capture system, or dry seal centrifugal compressor affected facility, the information specified in paragraphs (b)(5)(vi) through (ix) of this section.

(i) An identification of each centrifugal compressor constructed, modified, or reconstructed during the reporting period.

(ii) For each deviation that occurred during the reporting period and recorded as specified in paragraph (c)(4) of this section, the date and time the deviation began, the duration of the deviation in hours, and a description of the deviation. If no deviations occurred during the reporting period, you must include a statement that no deviations occurred during the reporting period.

(iii) If required to comply with § 60.5380b(a)(2), the information specified in paragraphs (b)(11)(i) through (iv) of this section.

(iv) If complying with § 60.5380b(a)(1) with a control device, identification of the centrifugal compressor with the control device and the information in paragraph (b)(11)(v) of this section.

(v) If you comply with an alternative GHG and VOC standard under § 60.5398b, in lieu of the information specified in paragraphs (b)(11)(i) and (ii) of this section, you must provide the information specified in § 60.5424b.

(vi) If complying with § 60.5380b(a)(4) or (5) for a self-contained wet seal centrifugal compressor, Alaska North Slope centrifugal compressor equipped with sour seal oil separator and capture system, or dry seal centrifugal compressor requirements, the cumulative number of hours of operation since initial startup, since May 7, 2024, or since the previous volumetric flow rate emissions measurement, as applicable, which have elapsed prior to conducting your volumetric flow rate emission measurement or emissions screening.

(vii) A description of the method used and the results of the volumetric emissions measurement or emissions screening, as applicable.

(viii) Number and type of seals on delay of repair and explanation for each delay of repair.

(ix) Date of planned shutdown(s) that occurred during the reporting period if there are any seals that have been placed on delay of repair.

(6) For each reciprocating compressor affected facility, the information specified in paragraphs (b)(6)(i) through (vii) of this section, as applicable.

(i) The cumulative number of hours of operation since initial startup, since May 7, 2024, or since the previous volumetric flow rate measurement, or since the previous reciprocating

compressor rod packing replacement, as applicable, which have elapsed prior to conducting your volumetric flow rate measurement or emissions screening. Alternatively, a statement that emissions from the rod packing are being routed to a process or control device through a closed vent system.

(ii) If applicable, for each deviation that occurred during the reporting period and recorded as specified in paragraph (c)(5)(i) of this section, the date and time the deviation began, duration of the deviation in hours and a description of the deviation. If no deviations occurred during the reporting period, you must include a statement that no deviations occurred during the reporting period.

(iii) A description of the method used and the results of the volumetric flow rate measurement or emissions screening, as applicable.

(iv) If complying with § 60.5385b(d), the information in paragraphs (b)(11)(i) through (iv) of this section.

(v) Number and type of rod packing replacements/repairs on delay of repair and explanation for each delay of repair.

(vi) Date of planned shutdown(s) that occurred during the reporting period if there are any rod packing replacements/repairs that have been placed on delay of repair.

(vii) If you comply with an alternative GHG and VOC standard under § 60.5398b, in lieu of the information specified in paragraphs (b)(11)(i) and (ii) of this section, you must provide the information specified in § 60.5424b.

(7) For each process controller affected facility, the information specified in paragraphs (b)(7)(i) through (iii) of this section in your initial annual report and in subsequent annual reports for each process controller affected facility that is constructed, modified, or reconstructed during the reporting period. Each annual report must contain the information specified in paragraphs (b)(7)(iv) through (x) of this section for each process controller affected facility.

(i) An identification of each process controller that is driven by natural gas, as required by § 60.5390b(d), that allows traceability to the records required in paragraph (c)(6)(i) of this section.

(ii) For each process controller in the affected facility complying with § 60.5390b(a), you must report the information specified in paragraphs (b)(7)(ii)(A) and (B) of this section, as applicable.

(A) An identification of each process controller complying with § 60.5390b(a) by routing the emissions to a process.

(B) An identification of each process controller complying with § 60.5390b(a)

by using a self-contained natural gas-driven process controller.

(iii) For each process controller affected facility located at a site in Alaska that does not have access to electrical power and that complies with § 60.5390b(b), you must report the information specified in paragraphs (b)(7)(iii)(A), (B), or (C) of this section, as applicable.

(A) For each process controller complying with § 60.5390b(b)(1) process controller bleed rate requirements, you must report the information specified in paragraphs (b)(7)(iii)(A)(1) and (2) of this section.

(1) The identification of process controllers designed and operated to achieve a bleed rate less than or equal to 6 scfh.

(2) Where necessary to meet a functional need, the identification and demonstration why it is necessary to use a process controller with a natural gas bleed rate greater than 6 scfh.

(B) An identification of each intermittent vent process controller complying with the requirements in paragraph § 60.5390b(b)(2).

(C) An identification of each process controller complying with the requirements in § 60.5390b(b) by routing emissions to a control device in accordance with § 60.5390b(b)(3).

(iv) Identification of each process controller which changes its method of compliance during the reporting period and the applicable information specified in paragraphs (b)(7)(v) through (ix) of this section for the new method of compliance.

(v) For each process controller in the affected facility complying with the requirements of § 60.5390b(a) by routing the emissions to a process, you must report the information specified in (b)(11)(i) through (iii) of this section.

(vi) For each process controller in the affected facility complying with the requirements of § 60.5390b(a) by using a self-contained natural gas-driven process controller, you must report the information specified in paragraphs (b)(7)(vi)(A) and (B) of this section.

(A) Dates of each inspection required under § 60.5416b(b); and

(B) Each defect or leak identified during each natural gas-driven-self-contained process controller system inspection, and the date of repair or date of anticipated repair if repair is delayed.

(vii) For each process controller in the affected facility complying with the requirements of § 60.5390b(b)(2), you must report the information specified in paragraphs (b)(7)(vii)(A) and (B) of this section.

(A) Dates and results of the intermittent vent process controller

monitoring required by § 60.5390b(b)(2)(ii).

(B) For each instance in which monitoring identifies emissions to the atmosphere from an intermittent vent controller during idle periods, the date of repair or replacement or the date of anticipated repair or replacement if the repair or replacement is delayed, and the date and results of the re-survey after repair or replacement.

(viii) For each process controller affected facility complying with § 60.5390b(b)(3) by routing emissions to a control device, you must report the information specified in paragraph (b)(11) of this section.

(ix) For each deviation that occurred during the reporting period, the date and time the deviation began, the duration of the deviation in hours, and a description of the deviation. If no deviations occurred during the reporting period, you must include a statement that no deviations occurred during the reporting period.

(x) If you comply with an alternative GHG and VOC standard under § 60.5398b, in lieu of the information specified in paragraphs (b)(7)(ii)(B) and (b)(11)(i) and (ii) of this section, you must provide the information specified in § 60.5424b.

(8) For each storage vessel affected facility, the information in paragraphs (b)(8)(i) through (x) of this section.

(i) An identification, including the location, of each storage vessel affected facility, including those for which construction, modification, or reconstruction commenced during the reporting period, and those provided in previous reports. The location of the storage vessel affected facility shall be in latitude and longitude coordinates in decimal degrees to an accuracy and precision of five (5) decimals of a degree using the North American Datum of 1983.

(ii) Documentation of the methane and VOC emission rate determination according to § 60.5365b(e)(1) for each tank battery that became an affected facility during the reporting period or is returned to service during the reporting period.

(iii) For each deviation that occurred during the reporting period and recorded as specified in paragraph (c)(7)(iii) of this section, the date and time the deviation began, duration of the deviation in hours and a description of the deviation. If no deviations occurred during the reporting period, you must include a statement that no deviations occurred during the reporting period.

(iv) For each storage vessel affected facility constructed, modified,

reconstructed, or returned to service during the reporting period complying with § 60.5395b(a)(2) with a control device, report the identification of the storage vessel affected facility with the control device and the information in paragraph (b)(11)(v) of this section.

(v) If you comply with an alternative GHG and VOC standard under § 60.5398b, in lieu of the information specified in paragraphs (b)(11)(i) and (ii) of this section, you must provide the information specified in § 60.5424b.

(vi) If required to comply with § 60.5395b(b)(1), the information in paragraphs (b)(11)(i) through (iv) of this section.

(vii) You must identify each storage vessel affected facility that is removed from service during the reporting period as specified in § 60.5395b(c)(1)(ii), including the date the storage vessel affected facility was removed from service. You must identify each storage vessel that is removed from service from a storage vessel affected facility during the reporting period as specified in § 60.5395b(c)(2)(iii), including identifying the impacted storage vessel affected facility and the date each storage vessel was removed from service.

(viii) You must identify each storage vessel affected facility or portion of a storage vessel affected facility returned to service during the reporting period as specified in § 60.5395b(c)(4), including the date the storage vessel affected facility or portion of a storage vessel affected facility was returned to service.

(ix) You must identify each storage vessel affected facility that no longer complies with § 60.5395b(a)(3) and instead complies with § 60.5395b(a)(2). You must identify whether the change in the method of compliance was due to fracturing or refracturing or whether the change was due to an increase in the monthly emissions determination. If the change was due to an increase in the monthly emissions determination, you must provide documentation of the emissions rate. You must identify the date that you complied with § 60.5395b(a)(2) and must submit the information in (b)(8)(iii) through (vii) of this section.

(x) You must submit a statement that you are complying with § 60.112b(a)(1) or (2), if applicable, in your initial annual report.

(9) For the fugitive emissions components affected facility, report the information specified in paragraphs (b)(9)(i) through (v) of this section, as applicable.

(i)(A) Designation of the type of site (*i.e.*, well site, centralized production facility, or compressor station) at which

the fugitive emissions components affected facility is located.

(B) For the fugitive emissions components affected facility at a well site or centralized production facility that became an affected facility during the reporting period, you must include the date of the startup of production or the date of the first day of production after modification. For the fugitive emissions components affected facility at a compressor station that became an affected facility during the reporting period, you must include the date of startup or the date of modification.

(C) For the fugitive emissions components affected facility at a well site, you must specify what type of well site it is (*i.e.*, single wellhead only well site, small wellsite, multi-wellhead only well site, or a well site with major production and processing equipment).

(D) For the fugitive emissions components affected facility at a well site where during the reporting period you complete the removal of all major production and processing equipment such that the well site contains only one or more wellheads, you must include the date of the change to status as a wellhead only well site.

(E) For the fugitive emissions components affected facility at a well site where you previously reported under paragraph (b)(9)(i)(D) of this section the removal of all major production and processing equipment and during the reporting period major production and processing equipment is added back to the well site, the date that the first piece of major production and processing equipment is added back to the well site.

(F) For the fugitive emissions components affected facility at a well site where during the reporting period you undertake well closure requirements, the date of the cessation of production from all wells at the well site, the date you began well closure activities at the well site, and the dates of the notifications submitted in accordance with paragraph (a)(4) of this section.

(ii) For each fugitive emissions monitoring survey performed during the annual reporting period, the information specified in paragraphs (b)(9)(ii)(A) through (G) of this section.

(A) Date of the survey.

(B) Monitoring instrument or, if the survey was conducted by AVO methods, notation that AVO was used.

(C) Any deviations from the monitoring plan elements under § 60.5397b(c)(1), (2), and (7), (c)(8)(i), or (d) or a statement that there were no deviations from these elements of the monitoring plan.

(D) Number and type of components for which fugitive emissions were detected.

(E) Number and type of fugitive emissions components that were not repaired as required in § 60.5397b(h).

(F) Number and type of fugitive emission components (including designation as difficult-to-monitor or unsafe-to-monitor, if applicable) on delay of repair and explanation for each delay of repair.

(G) Date of planned shutdown(s) that occurred during the reporting period if there are any components that have been placed on delay of repair.

(iii) For the fugitive emissions components affected facility complying with an alternative fugitive emissions standard under § 60.5399b, in lieu of the information specified in paragraphs (b)(9)(i) and (ii) of this section, you must provide the information specified in paragraphs (b)(9)(iii)(A) through (C) of this section.

(A) The alternative standard with which you are complying.

(B) The site-specific reports specified by the specific alternative fugitive emissions standard, submitted in the format in which they were submitted to the state, local, or Tribal authority. If the report is in hard copy, you must scan the document and submit it as an electronic attachment to the annual report required in paragraph (b) of this section.

(C) If the report specified by the specific alternative fugitive emissions standard is not site-specific, you must submit the information specified in paragraphs (b)(9)(i) and (ii) of this section for each individual site complying with the alternative standard.

(iv) For well closure activities which occurred during the reporting period, the information in paragraphs (b)(9)(iv)(A) and (B) of this section.

(A) A status report with dates for the well closure activities schedule developed in the well closure plan. If all steps in the well closure plan are completed in the reporting period, the date that all activities are completed.

(B) If an OGI survey is conducted during the reporting period, the information in paragraphs (b)(9)(iv)(B)(1) through (3) of this section.

(1) Date of the OGI survey.

(2) Monitoring instrument used.

(3) A statement that no fugitive emissions were found, or if fugitive emissions were found, a description of the steps taken to eliminate those emissions, the date of the resurvey, the results of the resurvey, and the date of

the final resurvey which detected no emissions.

(v) If you comply with an alternative GHG and VOC standard under § 60.5398b, in lieu of the information specified in paragraphs (b)(9)(i) and (ii) of this section, you must provide the information specified in § 60.5424b.

(10) For each pump affected facility, the information specified in paragraphs (b)(10)(i) through (iv) of this section in your initial annual report and in subsequent annual reports for each pump affected facility that is constructed, modified, or reconstructed during the reporting period. Each annual report must contain the information specified in paragraphs (b)(10)(v) through (ix) of this section for each pump affected facility.

(i) The identification of each of your pumps that are driven by natural gas, as required by § 60.5393b(a) that allows traceability to the records required by paragraph (c)(15)(i) of this section.

(ii) For each pump affected facility for which there is a control device on site but it does not achieve a 95.0 percent emissions reduction, the certification that there is a control device available on site but it does not achieve a 95.0 percent emissions reduction required under § 60.5393b(b)(3). You must also report the emissions reduction percentage the control device is designed to achieve.

(iii) For each pump affected facility for which there is no control device or vapor recovery unit on site, the certification required under § 60.5393b(b)(4) that there is no control device or vapor recovery unit on site.

(iv) For each pump affected facility for which it is technically infeasible to route the emissions to a process or control device, the certification of technical infeasibility required under § 60.5393b(b)(5).

(v) For any pump affected facility which has previously reported as required under paragraph (b)(10)(i) through (iv) of this section and for which a change in the reported condition has occurred during the reporting period, provide the identification of the pump affected facility and the date that the pump affected facility meets one of the change conditions described in paragraphs (b)(10)(v)(A), (B), or (C) of this section.

(A) If you install a control device or vapor recovery unit, you must report that a control device or vapor recovery unit has been added to the site and that the pump affected facility now is required to comply with § 60.5393b(b)(1) or (3), as applicable.

(B) If your pump affected facility previously complied with

§ 60.5393b(b)(1) or (3) by routing emissions to a process or a control device and the process or control device is subsequently removed from the site or is no longer available such that there is no ability to route the emissions to a process or control device at the site, or that it is not technically feasible to capture and route the emissions to another control device or process located on site, report that you are no longer complying with the applicable requirements of § 60.5393b(b)(1) or (3) and submit the information provided in paragraphs (b)(10)(v)(B)(1) or (2) of this section.

(1) Certification that there is no control device or vapor recovery unit on site.

(2) Certification of the engineering assessment that it is technically infeasible to capture and route the emissions to another control device or process located on site.

(C) If any pump affected facility or individual natural gas-driven pump changes its method of compliance during the reporting period other than for the reasons specified in paragraphs (10)(v)(A) and (B) of this section, identify the new compliance method for each natural gas-driven pump within the affected facility which changes its method of compliance during the reporting period and provide the applicable information specified in paragraphs (b)(10)(ii) through (iv) and (vi) through (viii) of this section for the new method of compliance.

(vi) For each pump affected facility complying with the requirements of § 60.5393b(a), (b)(1), or (b)(3) by routing the emissions to a process, you must report the information specified in paragraphs (b)(11)(i) through (iv) of this section.

(vii) For each pump affected facility complying with the requirements of § 60.5393b(b)(1) or (3) by routing the emissions to a control device, you must report the information required under paragraph (b)(11) of this section.

(viii) For each deviation that occurred during the reporting period, the date and time the deviation began, the duration of the deviation in hours, and a description of the deviation. If no deviations occurred during the reporting period, you must include a statement that no deviations occurred during the reporting period.

(ix) If you comply with an alternative GHG and VOC standard under § 60.5398b, in lieu of the information specified in paragraphs (b)(11)(i) and (ii) of this section, you must provide the information specified in § 60.5424b.

(11) For each well, centrifugal compressor, reciprocating compressor,

storage vessel, process controller, pump, or process unit equipment affected facility which uses a closed vent system routed to a control device to meet the emissions reduction standard, you must submit the information in paragraphs (b)(11)(i) through (v) of this section. For each reciprocating compressor, process controller, pump, storage vessel, or process unit equipment which uses a closed vent system to route to a process, you must submit the information in paragraphs (b)(11)(i) through (iv) of this section. For each centrifugal compressor, reciprocating compressor, and storage vessel equipped with a cover, you must submit the information in paragraphs (b)(11)(i) and (ii) of this section.

(i) Dates of each inspection required under § 60.5416b(a) and (b).

(ii) Each defect or emissions identified during each inspection and the date of repair or the date of anticipated repair if the repair is delayed.

(iii) Date and time of each bypass alarm or each instance the key is checked out if you are subject to the bypass requirements of § 60.5416b(a)(4).

(iv) You must submit the certification signed by the qualified professional engineer or in-house engineer according to § 60.5411b(c) for each closed vent system routing to a control device or process in the reporting year in which the certification is signed.

(v) If you comply with the emissions standard for your well, centrifugal compressor, reciprocating compressor, storage vessel, process controller, pump, or process unit equipment affected facility with a control device, the information in paragraphs (b)(11)(v)(A) through (L) of this section, unless you use an enclosed combustion device or flare using an alternative test method approved under § 60.5412b(d). If you use an enclosed combustion device or flare using an alternative test method approved under § 60.5412b(d), the information in paragraphs (b)(11)(v)(A) through (C) and (L) through (P) of this section.

(A) Identification of the control device.

(B) Make, model, and date of installation of the control device.

(C) Identification of the affected facility controlled by the device.

(D) For each continuous parameter monitoring system used to demonstrate compliance for the control device, a unique continuous parameter monitoring system identifier and the make, model number, and date of last calibration check of the continuous parameter monitoring system.

(E) For each instance where there is a deviation of the control device in accordance with § 60.5417b(g)(1) through (3) or (g)(5) through (7) include the date and time the deviation began, the duration of the deviation in hours, the type of the deviation (*e.g.*, NHV operating limit, lack of pilot or combustion flame, condenser efficiency, bypass line flow, visible emissions), and cause of the deviation.

(F) For each instance where there is a deviation of the continuous parameter monitoring system in accordance with § 60.5417b(g)(4) include the date and time the deviation began, the duration of the deviation in hours, and cause of the deviation.

(G) For each visible emissions test following return to operation from a maintenance or repair activity, the date of the visible emissions test or observation of the video surveillance output, the length of the observation in minutes, and the number of minutes for which visible emissions were present.

(H) If a performance test was conducted on the control device during the reporting period, provide the date the performance test was conducted. Submit the performance test report following the procedures specified in paragraph (b)(12) of this section.

(I) If a demonstration of the NHV of the inlet gas to the enclosed combustion device or flare was conducted during the reporting period in accordance with § 60.5417b(d)(8)(iii), an indication of whether this is a re-evaluation of vent gas NHV and the reason for the re-evaluation; the applicable required minimum vent gas NHV; if twice daily samples of the vent stream were taken, the number of hourly average NHV values that are less than 1.2 times the applicable required minimum NHV; if continuous NHV sampling of the vent stream was conducted, the number of hourly average NHV values that are less than the required minimum vent gas NHV; if continuous combustion efficiency monitoring was conducted using an alternative test method approved under § 60.5412b(d), the number of values of the combustion efficiency that were less than 95.0 percent; the resulting determination of whether NHV monitoring is required or not in accordance with § 60.5417b(d)(8)(iii)(D) or (H); and an indication of whether the enclosed combustion device or flare has the potential to receive inert gases, and if so, whether the sampling included periods where the highest percentage of inert gases were sent to the enclosed combustion device or flare.

(J) If a demonstration was conducted in accordance with § 60.5417b(d)(8)(iv)

that the maximum potential pressure of units manifolded to an enclosed combustion device or flare cannot cause the maximum inlet flow rate established in accordance with § 60.5417b(f)(1) or a flare tip velocity limit of 18.3 meter/second (60 feet/second) to be exceeded, an indication of whether this is a re-evaluation of the gas flow and the reason for the re-evaluation; the demonstration conducted; and applicable engineering calculations.

(K) For each periodic sampling event conducted under § 60.5417b(d)(8)(iii)(G), provide the date of the sampling, the required minimum vent gas NHV, and the NHV value for each vent gas sample.

(L) For each flare and enclosed combustion device, provide the date each device is observed with OGI in accordance with § 60.5415b(f)(x) and whether uncombusted emissions were present. Provide the date each device was visibly observed during an AVO inspection in accordance with § 60.5415b(f)(x), whether the pilot or combustion flame was lit at the time of observation, and whether the device was found to be operating properly.

(M) An identification of the alternative test method used.

(N) For each instance where there is a deviation of the control device in accordance with § 60.5417b(i)(6)(i) or (iii) through (v) include the date and time the deviation began, the duration of the deviation in hours, the type of the deviation (*e.g.*, NHV_{cz} operating limit, lack of pilot or combustion flame, visible emissions), and cause of the deviation.

(O) For each instance where there is a deviation of the data availability in accordance with § 60.5417b(i)(6)(ii) include the date of each operating day when monitoring data are not available for at least 75 percent of the operating hours

(P) If no deviations occurred under paragraphs (b)(11)(v)(N) or (O) of this section, a statement that there were no deviations for the control device during the annual report period.

(Q) Any additional information required to be reported as specified by the Administrator as part of the alternative test method approval under § 60.5412b(d).

(12) Within 60 days after the date of completing each performance test (see § 60.8) required by this subpart, except testing conducted by the manufacturer as specified in § 60.5413b(d), you must submit the results of the performance test following the procedures specified in paragraph (d) of this section. Data collected using test methods that are supported by the EPA's Electronic

Reporting Tool (ERT) as listed on the EPA's ERT website (<https://www.epa.gov/electronic-reporting-air-emissions/electronic-reporting-tool-ert>) at the time of the test must be submitted in a file format generated using the EPA's ERT. Alternatively, you may submit an electronic file consistent with the extensible markup language (XML) schema listed on the EPA's ERT website. Data collected using test methods that are not supported by the EPA's ERT as listed on the EPA's ERT website at the time of the test must be included as an attachment in the ERT or alternate electronic file.

(13) For combustion control devices tested by the manufacturer in accordance with § 60.5413b(d), an electronic copy of the performance test results required by § 60.5413b(d) shall be submitted via email to Oil_and_Gas_PT@EPA.GOV unless the test results for that model of combustion control device are posted at the following website: <https://www.epa.gov/controlling-air-pollution-oil-and-natural-gas-industry>.

(14) If you had a super-emitter event during the reporting period, the start date of the super-emitter event, the duration of the super-emitter event in hours, and the affected facility associated with the super-emitter event, if applicable.

(15) You must submit your annual report using the appropriate electronic report template on the Compliance and Emissions Data Reporting Interface (CEDRI) website for this subpart and following the procedure specified in paragraph (d) of this section. If the reporting form specific to this subpart is not available on the CEDRI website at the time that the report is due, you must submit the report to the Administrator at the appropriate address listed in § 60.4. Once the form has been available on the CEDRI website for at least 90 calendar days, you must begin submitting all subsequent reports via CEDRI. The date reporting forms become available will be listed on the CEDRI website. Unless the Administrator or delegated state agency or other authority has approved a different schedule for submission of reports, the report must be submitted by the deadline specified in this subpart, regardless of the method in which the report is submitted.

(c) *Recordkeeping requirements.* You must maintain the records identified as specified in § 60.7(f) and in paragraphs (c)(1) through (15) of this section. All records required by this subpart must be maintained either onsite or at the nearest local field office for at least 5 years. Any records required to be maintained by this subpart that are

submitted electronically via the EPA's CEDRI may be maintained in electronic format. This ability to maintain electronic copies does not affect the requirement for facilities to make records, data, and reports available upon request to a delegated air agency or the EPA as part of an on-site compliance evaluation.

(1) The records for each well affected facility subject to the well completion operation standards of § 60.5375b, as specified in paragraphs (c)(1)(i) through (vii) of this section, as applicable. For each well affected facility subject to the well completion operations of § 60.5375b, for which you make a claim that the well affected facility is not subject to the requirements for well completions pursuant to § 60.5375b(g), you must maintain the record in paragraph (c)(1)(vi) of this section, only. For each well affected facility which meets the exemption in § 60.5375b(h) for well completion operations (*i.e.*, an existing well is hydraulically refractured), you must maintain the records in paragraph (c)(1)(viii), only. For each well affected facility that routes flowback entirely through one or more production separators that are designed to accommodate flowback, only records of the United States Well Number, the latitude and longitude of the well in decimal degrees to an accuracy and precision of five (5) decimals of a degree using North American Datum of 1983, the Well Completion ID, and the date and time of startup of production are required. For periods where salable gas is unable to be separated, records of the date and time of onset of flowback, the duration and disposition of recovery, the duration of combustion and venting (if applicable), reasons for venting (if applicable), and deviations are required.

(i) Records identifying each well completion operation for each well affected facility.

(ii) Records of deviations in cases where well completion operations with hydraulic fracturing were not performed in compliance with the requirements specified in § 60.5375b, including the date and time the deviation began, the duration of the deviation, and a description of the deviation.

(iii) You must maintain the records specified in paragraphs (c)(1)(iii)(A) through (C) of this section.

(A) For each well affected facility required to comply with the requirements of § 60.5375b(a), you must record: The latitude and longitude of the well in decimal degrees to an accuracy and precision of five (5) decimals of a degree using North American Datum of 1983; the United States Well Number;

the date and time of the onset of flowback following hydraulic fracturing or refracturing; the date and time of each attempt to direct flowback to a separator as required in § 60.5375b(a)(1)(ii); the date and time of each occurrence of returning to the initial flowback stage under § 60.5375b(a)(1)(i); and the date and time that the well was shut in and the flowback equipment was permanently disconnected, or the startup of production; the duration of flowback; duration of recovery and disposition of recovery (*i.e.*, routed to the gas flow line or collection system, re-injected into the well or another well, used as an onsite fuel source, or used for another useful purpose that a purchased fuel or raw material would serve); duration of combustion; duration of venting; and specific reasons for venting in lieu of capture or combustion. The duration must be specified in hours. In addition, for wells where it is technically infeasible to route the recovered gas as specified in § 60.5375b(a)(1)(ii), you must record the reasons for the claim of technical infeasibility with respect to all four options provided in § 60.5375b(a)(1)(ii).

(B) For each well affected facility required to comply with the requirements of § 60.5375b(f), you must record: Latitude and longitude of the well in decimal degrees to an accuracy and precision of five (5) decimals of a degree using North American Datum of 1983; the United States Well Number; the date and time of the onset of flowback following hydraulic fracturing or refracturing; the date and time that the well was shut in and the flowback equipment was permanently disconnected, or the startup of production; the duration of flowback; duration of combustion; duration of venting; and specific reasons for venting in lieu of combustion. The duration must be specified in hours.

(C) For each well affected facility for which you make a claim that it meets the criteria of § 60.5375b(a)(1)(iii)(A), you must maintain the following:

(1) The latitude and longitude of the well in decimal degrees to an accuracy and precision of five (5) decimals of a degree using North American Datum of 1983; the United States Well Number; the date and time of the onset of flowback following hydraulic fracturing or refracturing; the date and time that the well was shut in and the flowback equipment was permanently disconnected, or the startup of production; the duration of flowback; duration of recovery and disposition of recovery (*i.e.*, routed to the gas flow line or collection system, re-injected into the

well or another well, used as an onsite fuel source, or used for another useful purpose that a purchased fuel or raw material would serve); duration of combustion; duration of venting; and specific reasons for venting in lieu of capture or combustion. The duration must be specified in hours.

(2) If applicable, records that the conditions of § 60.5375b(a)(1)(iii)(A) are no longer met and that the well completion operation has been stopped and a separator installed. The records shall include the date and time the well completion operation was stopped and the date and time the separator was installed.

(3) A record of the claim signed by the certifying official that no liquids collection is at the well site. The claim must include a certification by a certifying official of truth, accuracy, and completeness. This certification shall state that, based on information and belief formed after reasonable inquiry, the statements and information in the document are true, accurate, and complete.

(iv) For each well affected facility for which you claim an exception under § 60.5375b(a)(2), you must record: The latitude and longitude of the well in decimal degrees to an accuracy and precision of five (5) decimals of a degree using North American Datum of 1983; the United States Well Number; the specific exception claimed; the starting date and ending date for the period the well operated under the exception; and an explanation of why the well meets the claimed exception.

(v) For each well affected facility required to comply with both § 60.5375b(a)(1) and (2), if you are using a digital photograph in lieu of the records required in paragraphs (c)(1)(i) through (iv) of this section, you must retain the records of the digital photograph as specified in § 60.5410b(a)(4).

(vi) For each well affected facility for which you make a claim that the well affected facility is not subject to the well completion standards according to § 60.5375b(g), you must maintain:

(A) A record of the analysis that was performed in order to make that claim, including but not limited to, GOR values for established leases and data from wells in the same basin and field;

(B) The latitude and longitude of the well in decimal degrees to an accuracy and precision of five (5) decimals of a degree using North American Datum of 1983; the United States Well Number;

(C) A record of the claim signed by the certifying official. The claim must include a certification by a certifying official of truth, accuracy, and

completeness. This certification shall state that, based on information and belief formed after reasonable inquiry, the statements and information in the document are true, accurate, and complete.

(vii) For each well affected facility subject to § 60.5375b(f), a record of the well type (*i.e.*, wildcat well, delineation well, or low pressure well (as defined § 60.5430b)) and supporting inputs and calculations, if applicable.

(viii) For each well affected facility which makes a claim it meets the exemption at § 60.5375b(h), a record of the latitude and longitude of the well in decimal degrees to an accuracy and precision of five (5) decimals of a degree using North American Datum of 1983; the United States Well Number; the date and time of the onset of flowback following hydraulic fracturing or refracturing and a record of the claim that the well completion operation requirements of § 60.5375b(a)(1) through (3) were met.

(2) For each gas well liquids unloading operation at your well affected facility that is subject to § 60.5376b(a)(1) or (2), the records of each gas well liquids unloading operation conducted during the reporting period, including the information specified in paragraphs (c)(2)(i) through (iii) of this section, as applicable.

(i) For each gas well liquids unloading operation that complies with § 60.5376b(a)(1) by performing all liquids unloading events without venting of methane and VOC emissions to the atmosphere, comply with the recordkeeping requirements specified in paragraphs (c)(2)(i)(A) and (B) of this section.

(A) Identification of each well (*i.e.*, U.S. Well ID or U.S. Well ID associated with the well affected facility) that conducts a gas well liquids unloading operation during the reporting period without venting of methane and VOC emissions and the non-venting methane and VOC gas well liquids unloading method used. If more than one non-venting method is used, you must maintain records all of the differing non-venting liquids unloading methods used at the well affected facility complying with § 60.5376b(a)(1).

(B) Number of events where unplanned emissions are vented to the atmosphere during a gas well liquids unloading operation where you complied with best management practices to minimize emissions to the maximum extent possible.

(ii) For each gas well liquids unloading operation that complies with § 60.5376b(b) and (c) best management

practices, maintain records documenting information specified in paragraphs (c)(2)(ii)(A) through (D) of this section.

(A) Identification of each well affected facility that conducts liquids unloading during the reporting period that employs best management practices to minimize emissions to the maximum extent possible.

(B) Documentation of your best management practice plan developed under paragraph § 60.5376b(c). You may update your best management practice plan to include additional steps which meet the criteria in § 60.5376b(c).

(C) A log of each best management practice plan step taken minimize emissions to the maximum extent possible for each gas well liquids unloading event.

(D) Documentation of each gas well liquids unloading event where deviations from your best management practice plan steps occurred, the date and time the deviation began, the duration of the deviation, documentation of best management practice plans steps were not followed, and the steps taken in lieu of your best management practice plan steps during those events to minimize emissions to the maximum extent possible.

(iii) For each well affected facility that reduces methane and VOC emissions from well affected facility gas wells that unload liquids by 95.0 percent by routing emissions to a control device through closed vent system under § 60.5376b(g), you must maintain the records in paragraphs (c)(2)(iii)(A) through (E) of this section.

(A) If you comply with the emission reduction standard with a control device, the information for each control device in paragraph (c)(11) of this section.

(B) Records of the closed vent system inspection as specified paragraph (c)(8) of this section.

(C) Records of the cover inspections as specified in paragraph (c)(9) of this section.

(D) If applicable, the records of bypass monitoring as specified in paragraph (c)(10) of this section.

(E) Records of the closed vent system assessment as specified in paragraph (c)(12) of this section.

(3) For each associated gas well, you must maintain the applicable records specified in paragraphs (c)(3)(i) or (ii) and (c)(3)(iv) of this section.

(i) For each associated gas well that complies with the requirements of § 60.5377b(a)(1), (2), (3), or (4), you must keep the records specified in paragraphs (c)(3)(i)(A) and (B).

(A) Documentation of the specific method(s) in § 60.5377b(a)(1), (2), (3), or (4) that is used.

(B) For instances where you temporarily route the associated gas to a flare or control device in accordance with § 60.5377b(d), you must keep the records specified in paragraphs (c)(3)(i)(B)(1) through (3).

(1) The reason in § 60.5377b(d)(1), (2), (3), or (4) for each incident.

(2) The date of each incident, along with the times when routing the associated gas to the flare or control device started and ended, along with the total duration of each incident.

(3) Documentation that all CVS requirements specified in § 60.5411b(a) and (c) and all applicable flare or control device requirements specified in § 60.5412b are met during each period when the associated gas is routed to the flare or control device.

(ii) For instances where you temporarily vent the associated gas in accordance with § 60.5377b(e), you must keep the records specified in paragraphs (c)(3)(ii)(A) through (D). These records are required if you are routinely complying with § 60.5377b(a) or § 60.5377b(f) or temporarily complying with § 60.5377b(d).

(A) The reason in § 60.5377b(e)(1), (2), or (3) for each incident.

(B) The date of each incident, along with the times when venting the associated gas started and ended, along with the total duration of each incident.

(C) The VOC and methane emissions that were emitted during each incident.

(D) The cumulative duration of venting incidents and VOC and methane emissions for all incidents in each calendar year.

(iii) For each associated gas well that complies with the requirements of § 60.5377b(f) because it has demonstrated that it is not feasible to comply with § 60.5377b(a)(1), (2), (3), and (4) due to technical reasons in accordance with § 60.5377b(g), records of each annual demonstration and certification of the technical reason that it is not feasible to comply with § 60.5377b(a)(1), (2), (3), and (4) in accordance with § 60.5377b(g).

(iv) For each associated gas well that complies with the requirements of § 60.5377b(f), meet the recordkeeping requirements specified in paragraphs (c)(3)(iv)(A) through (E).

(A) Identification of each instance when associated gas was vented and not routed to a control device that reduces VOC and methane emissions by at least 95.0 percent.

(B) If you comply with the emission reduction standard in § 60.5380b with a control device, the information for each

control device in paragraph (c)(11) of this section.

(C) Records of the closed vent system inspection as specified paragraph (c)(8) of this section. If you comply with an alternative GHG and VOC standard under § 60.5398b, in lieu of the information specified in paragraph (c)(8) of this section, you must maintain records of the information specified in § 60.5424b.

(D) If applicable, the records of bypass monitoring as specified in paragraph (c)(10) of this section.

(E) Records of the closed vent system assessment as specified in paragraph (c)(12) of this section.

(v) Records of each deviation, the date and time the deviation began, the duration of the deviation, and a description of the deviation.

(4) For each centrifugal compressor affected facility, you must maintain the records specified in paragraphs (c)(4)(i) through (iii) of this section.

(i) For each centrifugal compressor affected facility, you must maintain records of deviations in cases where the centrifugal compressor was not operated in compliance with the requirements specified in § 60.5380b, including a description of each deviation, the date and time each deviation began and the duration of each deviation.

(ii) For each wet seal compressor complying with the emissions reduction standard in § 60.5380b(a)(1), you must maintain the records in paragraphs (c)(4)(ii)(A) through (E) of this section. For each wet seal compressor complying with the alternative standard in § 60.5380b(a)(3) by routing the closed vent system to a process, you must maintain the records in paragraphs (c)(4)(ii)(B) through (E) of this section.

(A) If you comply with the emission reduction standard in § 60.5380b(a)(1) with a control device, the information for each control device in paragraph (c)(11) of this section.

(B) Records of the closed vent system inspection as specified paragraph (c)(8) of this section. If you comply with an alternative GHG and VOC standard under § 60.5398b, in lieu of the information specified in paragraph (c)(8) of this section, you must maintain the information specified in § 60.5424b.

(C) Records of the cover inspections as specified in paragraph (c)(9) of this section. If you comply with an alternative GHG and VOC standard under § 60.5398b, in lieu of the information specified in paragraphs (c)(9) of this section, you must maintain the information specified in § 60.5424b.

(D) If applicable, the records of bypass monitoring as specified in paragraph (c)(10) of this section.

(E) Records of the closed vent system assessment as specified in paragraph (c)(12) of this section.

(iii) For each centrifugal compressor affected facility using a self-contained wet seal compressor, or dry seal compressor complying with the standard in § 60.5380b(a)(4) and (5), you must maintain the records specified in paragraphs (c)(4)(iii)(A) through (H) of this section.

(A) Records of the cumulative number of hours of operation since initial startup, since May 7, 2024, or since the previous volumetric flow rate measurement, as applicable.

(B) A description of the method used and the results of the volumetric flow rate measurement or emissions screening, as applicable.

(C) Records for all flow meters, composition analyzers and pressure gauges used to measure volumetric flow rates as specified in paragraphs (c)(4)(iii)(C)(1) through (6).

(1) Description of standard method published by a consensus-based standards organization or industry standard practice.

(2) Records of volumetric flow rate emissions calculations conducted according to paragraphs § 60.5380b(a)(5), as applicable.

(3) Records of manufacturer's operating procedures and measurement methods.

(4) Records of manufacturer's recommended procedures or an appropriate industry consensus standard method for calibration and results of calibration, recalibration, and accuracy checks.

(5) Records which demonstrate that measurements at the remote location(s) can, when appropriate correction factors are applied, reliably and accurately represent the actual temperature or total pressure at the flow meter under all expected ambient conditions. You must include the date of the demonstration, the data from the demonstration, the mathematical correlation(s) between the remote readings and actual flow meter conditions derived from the data, and any supporting engineering calculations. If adjustments were made to the mathematical relationships, a record and description of such adjustments.

(6) Record of each initial calibration or a recalibration which failed to meet the required accuracy specification and the date of the successful recalibration.

(D) Date when performance-based volumetric flow rate is exceeded.

(E) The date of successful repair of the compressor seal, including follow-up performance-based volumetric flow rate

measurement to confirm successful repair.

(F) Identification of each compressor seal placed on delay of repair and explanation for each delay of repair.

(G) For each compressor seal or part needed for repair placed on delay of repair because of replacement seal or part unavailability, the operator must document: the date the seal or part was added to the delay of repair list, the date the replacement seal or part was ordered, the anticipated seal or part delivery date (including any estimated shipment or delivery date provided by the vendor), and the actual arrival date of the seal or part.

(H) Date of planned shutdowns that occur while there are any seals or parts that have been placed on delay of repair.

(5) For each reciprocating compressor affected facility, you must maintain the records in paragraphs (c)(5)(i) through (x), and (c)(8), (c)(10) and (c)(12) of this section, as applicable. If you comply with an alternative GHG and VOC standard under § 60.5398b, in lieu of the information specified in paragraph (c)(8) of this section, you must provide the information specified in § 60.5424b.

(i) For each reciprocating compressor affected facility, you must maintain records of deviations in cases where the reciprocating compressor was not operated in compliance with the requirements specified in § 60.5385b, including a description of each deviation, the date and time each deviation began and the duration of each deviation in hours.

(ii) Records of the date of installation of a rod packing emissions collection system and closed vent system as specified in § 60.5385b(d).

(iii) Records of the cumulative number of hours of operation since initial startup, since May 7, 2024, or since the previous volumetric flow rate measurement, as applicable. Alternatively, a record that emissions from the rod packing are being routed to a process through a closed vent system.

(iv) A description of the method used and the results of the volumetric flow rate measurement or emissions screening, as applicable.

(v) Records for all flow meters, composition analyzers and pressure gauges used to measure volumetric flow rates as specified in paragraphs (c)(5)(v)(A) through (F).

(A) Description of standard method published by a consensus-based standards organization or industry standard practice.

(B) Records of volumetric flow rate calculations conducted according to paragraphs § 60.5385b(b) or (c), as applicable.

(C) Records of manufacturer operating procedures and measurement methods.

(D) Records of manufacturer's recommended procedures or an appropriate industry consensus standard method for calibration and results of calibration, recalibration, and accuracy checks.

(E) Records which demonstrate that measurements at the remote location(s) can, when appropriate correction factors are applied, reliably and accurately represent the actual temperature or total pressure at the flow meter under all expected ambient conditions. You must include the date of the demonstration, the data from the demonstration, the mathematical correlation(s) between the remote readings and actual flow meter conditions derived from the data, and any supporting engineering calculations. If adjustments were made to the mathematical relationships, a record and description of such adjustments.

(F) Record of each initial calibration or a recalibration which failed to meet the required accuracy specification and the date of the successful recalibration.

(vi) Date when performance-based volumetric flow rate is exceeded.

(vii) The date of successful replacement or repair of reciprocating compressor rod packing, including follow-up performance-based volumetric flow rate measurement to confirm successful repair.

(viii) Identification of each reciprocating compressor placed on delay of repair because of rod packing or part unavailability and explanation for each delay of repair.

(ix) For each reciprocating compressor that is placed on delay of repair because of replacement rod packing or part unavailability, the operator must document: the date the rod packing or part was added to the delay of repair list, the date the replacement rod packing or part was ordered, the anticipated rod packing or part delivery date (including any estimated shipment or delivery date provided by the vendor), and the actual arrival date of the rod packing or part.

(x) Date of planned shutdowns that occur while there are any reciprocating compressors that have been placed on delay of repair due to the unavailability of rod packing or parts to conduct repairs.

(6) For each process controller affected facility, you must maintain the records specified in paragraphs (c)(6)(i) through (vii) of this section.

(i) Records identifying each process controller that is driven by natural gas and that does not function as an emergency shutdown device.

(ii) For each process controller affected facility complying with § 60.5390b(a), you must maintain records of the information specified in paragraphs (c)(6)(ii)(A) and (B) of this section, as applicable.

(A) If you are complying with § 60.5390b(a) by routing process controller vapors to a process through a closed vent system, you must report the information specified in paragraphs (c)(6)(ii)(A)(1) and (2) of this section.

(1) An identification of all the natural gas-driven process controllers in the process controller affected facility for which you collect and route vapors to a process through a closed vent system.

(2) The records specified in paragraphs (c)(8), (10), and (12) of this section. If you comply with an alternative GHG and VOC standard under § 60.5398b, in lieu of the information specified in paragraph (c)(8) of this section, you must provide the information specified in § 60.5424b.

(B) If you are complying with § 60.5390b(a) by using a self-contained natural gas-driven process controller, you must report the information specified in paragraphs (c)(6)(ii)(B)(1) through (3) of this section.

(1) An identification of each process controller complying with § 60.5390b(a) by using a self-contained natural gas-driven process controller;

(2) Dates of each inspection required under § 60.5416b(b); and

(3) Each defect or leak identified during each natural gas-driven-self-contained process controller system inspection, and date of repair or date of anticipated repair if repair is delayed.

(iii) For each process controller affected facility complying with the § 60.5390b(b)(1) process controller bleed rate requirements, you must maintain records of the information specified in paragraphs (c)(6)(iii)(A) and (B) of this section.

(A) The identification of process controllers designed and operated to achieve a bleed rate less than or equal to 6 scfh and records of the manufacturer's specifications indicating that the process controller is designed with a natural gas bleed rate of less than or equal to 6 scfh.

(B) Where necessary to meet a functional need, the identification of the process controller and demonstration of why it is necessary to use a process controller with a natural gas bleed rate greater than 6 scfh.

(iv) For each intermittent vent process controller in the affected facility complying with the requirements in paragraphs § 60.5390b(b)(2), you must keep records of the information

specified in paragraphs (c)(6)(iv)(A) through (C) of this section.

(A) The identification of each intermittent vent process controller.

(B) Dates and results of the intermittent vent process controller monitoring required by § 60.5390b(b)(2)(ii).

(C) For each instance in which monitoring identifies emissions to the atmosphere from an intermittent vent controller during idle periods, the date of repair or replacement, or the date of anticipated repair or replacement if the repair or replacement is delayed and the date and results of the re-survey after repair or replacement.

(v) For each process controller affected facility complying with § 60.5390b(b)(3), you must maintain the records specified in paragraphs (c)(6)(v)(A) and (B) of this section.

(A) An identification of each process controller for which emissions are routed to a control device.

(B) Records specified in paragraphs (c)(8) and (c)(10) through (13) of this section. If you comply with an alternative GHG and VOC standard under § 60.5398b, in lieu of the information specified in paragraph (c)(8) of this section, you must provide the information specified in § 60.5424b.

(vi) Records of each change in compliance method, including identification of each natural gas-driven process controller which changes its method of compliance, the new method of compliance, and the date of the change in compliance method.

(vii) Records of each deviation, the date and time the deviation began, the duration of the deviation, and a description of the deviation.

(7) For each storage vessel affected facility, you must maintain the records identified in paragraphs (c)(7)(i) through (vii) of this section.

(i) You must maintain records of the identification and location in latitude and longitude coordinates in decimal degrees to an accuracy and precision of five (5) decimals of a degree using the North American Datum of 1983 of each storage vessel affected facility.

(ii) Records of each methane and VOC emissions determination for each storage vessel affected facility made under § 60.5365b(e) including identification of the model or calculation methodology used to calculate the methane and VOC emission rate.

(iii) For each instance where the storage vessel was not operated in compliance with the requirements specified in § 60.5395b a description of the deviation, the date and time each

deviation began, and the duration of the deviation.

(iv) If complying with the emissions reduction standard in § 60.5395b(a)(2), you must maintain the records in paragraphs (c)(7)(iv)(A) through (E) of this section.

(A) If you comply with the emission reduction standard with a control device, the information for each control device in paragraph (c)(11) of this section.

(B) Records of the closed vent system inspection as specified paragraph (c)(8) of this section. If you comply with an alternative GHG and VOC standard under § 60.5398b, in lieu of the information specified in paragraph (c)(8) of this section, you must provide the information specified in § 60.5424b.

(C) Records of the cover inspections as specified in paragraph (c)(9) of this section. If you comply with an alternative GHG and VOC standard under § 60.5398b, in lieu of the information specified in paragraphs (c)(9) of this section, you must provide the information specified in § 60.5424b.

(D) If applicable, the records of bypass monitoring as specified in paragraph (c)(10) of this section.

(E) Records of the closed vent system assessment as specified in paragraph (c)(12) of this section.

(v) For storage vessels that are skid-mounted or permanently attached to something that is mobile (such as trucks, railcars, barges or ships), records indicating the number of consecutive days that the vessel is located at a site in the crude oil and natural gas source category. If a storage vessel is removed from a site and, within 30 days, is either returned to the site or replaced by another storage vessel at the site to serve the same or similar function, then the entire period since the original storage vessel was first located at the site, including the days when the storage vessel was removed, will be added to the count towards the number of consecutive days.

(vi) Records of the date that each storage vessel affected facility or portion of a storage vessel affected facility is removed from service and returned to service, as applicable.

(vii) Records of the date that liquids from the well following fracturing or refracturing are routed to the storage vessel affected facility; or the date that you comply with paragraph § 60.5395b(a)(2), following a monthly emissions determination which indicates that VOC emissions from your storage vessel affected facility increase to 4 tpy or greater or methane emissions increase to 14 tpy or greater and the increase is not associated with

fracturing or refracturing of a well feeding the storage vessel affected facility, and records of the methane and VOC emissions rate and the model or calculation methodology used to calculate the methane and VOC emission rate.

(8) Records of each closed vent system inspection required under § 60.5416b(a)(1) and (2) and (b) for your well, centrifugal compressor, reciprocating compressor, process controller, pump, storage vessel, and process unit equipment affected facility as required in paragraphs (c)(8)(i) through (iv) of this section.

(i) A record of each closed vent system inspection or no identifiable emissions monitoring survey. You must include an identification number for each closed vent system (or other unique identification description selected by you), the date of the inspection, and the method used to conduct the inspection (*i.e.*, visual, AVO, OGI, Method 21 of appendix A–7 to this part).

(ii) For each defect or emissions detected during inspections required by § 60.5416b(a)(1) and (2), or (b) you must record the location of the defect or emissions; a description of the defect; the maximum concentration reading obtained if using Method 21 of appendix A–7 to this part; the indication of emissions detected by AVO if using AVO; the date of detection; the date of each attempt to repair the emissions or defect; the corrective action taken during each attempt to repair the defect; and the date the repair to correct the defect or emissions is completed.

(iii) If repair of the defect is delayed as described in § 60.5416b(b)(6), you must record the reason for the delay and the date you expect to complete the repair.

(iv) Parts of the closed vent system designated as unsafe to inspect as described in § 60.5416b(b)(7) or difficult to inspect as described in § 60.5416b(b)(8), the reason for the designation, and written plan for inspection of that part of the closed vent system.

(9) A record of each cover inspection required under § 60.5416b(a)(3) for your centrifugal compressor, reciprocating compressor, or storage vessel as required in paragraphs (c)(9)(i) through (iv) of this section.

(i) A record of each cover inspection. You must include an identification number for each cover (or other unique identification description selected by you), the date of the inspection, and the method used to conduct the inspection

(*i.e.*, AVO, OGI, Method 21 of appendix A–7 to this part).

(ii) For each defect detected during the inspection you must record the location of the defect; a description of the defect, the date of detection, the maximum concentration reading obtained if using Method 21 of appendix A–7 to this part; the indication of emissions detected by AVO if using AVO; the date of each attempt to repair the defect; the corrective action taken during each attempt to repair the defect; and the date the repair to correct the defect is completed.

(iii) If repair of the defect is delayed as described in § 60.5416b(b)(6), you must record the reason for the delay and the date you expect to complete the repair.

(iv) Parts of the cover designated as unsafe to inspect as described in § 60.5416b(b)(7) or difficult to inspect as described in § 60.5416b(b)(8), the reason for the designation, and written plan for inspection of that part of the cover.

(10) For each bypass subject to the bypass requirements of § 60.5416b(a)(4), you must maintain a record of the following, as applicable: readings from the flow indicator; each inspection of the seal or closure mechanism; the date and time of each instance the key is checked out; date and time of each instance the alarm is sounded.

(11) Records for each control device used to comply with the emission reduction standard in § 60.5377b(b) for associated gas wells, § 60.5380b(a)(1) for centrifugal compressor affected facilities, § 60.5385b(d)(2) for reciprocating compressor affected facilities, § 60.5390b(b)(3) for your process controller affected facility in Alaska, § 60.5393b(b)(1) for your pump affected facility, § 60.5395b(a)(2) for your storage vessel affected facility, § 60.5376b(f) for well affected facility gas well liquids unloading, or § 60.5400b(f) or 60.5401b(e) for your process equipment affected facility, as required in paragraphs (c)(11)(i) through (viii) of this section. If you use an enclosed combustion device or flare using an alternative test method approved under § 60.5412b(d), keep records of the information in paragraphs (c)(11)(ix) of this section, in lieu of the records required by paragraphs (c)(11)(i) through (iv) and (vi) through (viii) of this section.

(i) For a control device tested under § 60.5413b(d) which meets the criteria in § 60.5413b(d)(11) and (e), keep records of the information in paragraphs (c)(11)(i)(A) through (E) of this section, in addition to the records in paragraphs

(c)(11)(ii) through (ix) of this section, as applicable.

(A) Serial number of purchased device and copy of purchase order.

(B) Location of the affected facility associated with the control device in latitude and longitude coordinates in decimal degrees to an accuracy and precision of five (5) decimals of a degree using the North American Datum of 1983.

(C) Minimum and maximum inlet gas flow rate specified by the manufacturer.

(D) Records of the maintenance and repair log as specified in § 60.5413b(e)(4), for all inspection, repair, and maintenance activities for each control device failing the visible emissions test.

(E) Records of the manufacturer's written operating instructions, procedures, and maintenance schedule to ensure good air pollution control practices for minimizing emissions.

(ii) For all control devices, keep records of the information in paragraphs (c)(11)(i)(A) through (G) of this section, as applicable.

(A) Make, model, and date of installation of the control device, and identification of the affected facility controlled by the device.

(B) Records of deviations in accordance with § 60.5417b(g)(1) through (7), including a description of the deviation, the date and time the deviation began, the duration of the deviation, and the cause of the deviation.

(C) The monitoring plan required by § 60.5417b(c)(2).

(D) Make and model number of each continuous parameter monitoring system.

(E) Records of minimum and maximum operating parameter values, continuous parameter monitoring system data (including records that the pilot or combustion flame is present at all times), calculated averages of continuous parameter monitoring system data, and results of all compliance calculations.

(F) Records of continuous parameter monitoring system equipment performance checks, system accuracy audits, performance evaluations, or other audit procedures and results of all inspections specified in the monitoring plan in accordance with § 60.5417b(c)(2). Records of calibration gas cylinders, if applicable.

(G) Periods of monitoring system malfunctions, repairs associated with monitoring system malfunctions and required monitoring system quality assurance or quality control activities. Records of repairs on the monitoring system.

(iii) For each carbon adsorption system, records of the schedule for carbon replacement as determined by the design analysis requirements of § 60.5413b(c)(2) and (3) and records of each carbon replacement as specified in § 60.5412b(c)(1) and § 60.5415b(f)(1)(viii).

(iv) For enclosed combustion devices and flares, records of visible emissions observations as specified in paragraph (c)(11)(iv)(A) or (B) of this section.

(A) Records of observations with Method 22 of appendix A-7 to this part, including observations required following return to operation from a maintenance or repair activity, which include: company, location, company representative (name of the person performing the observation), sky conditions, process unit (type of control device), clock start time, observation period duration (in minutes and seconds), accumulated emission time (in minutes and seconds), and clock end time. You may create your own form including the above information or use Figure 22-1 in Method 22 of appendix A-7 to this part.

(B) If you monitor visible emissions with a video surveillance camera, location of the camera and distance to emission source, records of the video surveillance output, and documentation that an operator looked at the feed daily, including the date and start time of observation, the length of observation, and length of time visible emissions were present.

(v) For enclosed combustion devices and flares, video of the OGI inspection conducted in accordance with § 60.5415b(f)(x). Records documenting each enclosed combustion device and flare was visibly observed during each inspection conducted under § 60.5397b using AVO in accordance with § 60.5415b(f)(x).

(vi) For enclosed combustion devices and flares, records of each demonstration of the NHV of the inlet gas to the enclosed combustion device or flare conducted in accordance with § 60.5417b(d)(8)(iii). For each re-evaluation of the NHV of the inlet gas, records of process changes and explanation of the conditions that led to the need to re-evaluation the NHV of the inlet gas. For each demonstration, record information on whether the enclosed combustion device or flare has the potential to receive inert gases, and if so, the highest percentage of inert gases that can be sent to the enclosed combustion device or flare and the highest percent of inert gases sent to the enclosed combustion device or flare during the NHV demonstration. Records

of periodic sampling conducted under § 60.5417b(d)(8)(iii)(G).

(vii) For enclosed combustion devices and flares, if you use a backpressure regulator valve, the make and model of the valve, date of installation, and record of inlet flow rating. Maintain records of the engineering evaluation and manufacturer specifications that identify the pressure set point corresponding to the minimum inlet gas flow rate, the annual confirmation that the backpressure regulator valve set point is correct and consistent with the engineering evaluation and manufacturer specifications, and the annual confirmation that the backpressure regulator valve fully closes when not in open position.

(viii) For enclosed combustion devices and flares, records of each demonstration required under § 60.5417b(d)(8)(iv).

(ix) If you use an enclosed combustion device or flare using an alternative test method approved under § 60.5412b(d), keep records of the information in paragraphs (c)(11)(ix)(A) through (H) of this section, in lieu of the records required by paragraphs (c)(11)(i) through (iv) and (c)(11)(vi) through (viii) of this section.

(A) An identification of the alternative test method used.

(B) Data recorded at the intervals required by the alternative test method.

(C) Monitoring plan required by § 60.5417(i)(2).

(D) Quality assurance and quality control activities conducted in accordance with the alternative test method.

(E) If required by § 60.5412b(d)(4) to conduct visible emissions observations, records required by paragraph (c)(11)(iv) of this section.

(F) If required by § 60.5412b(d)(5) to conduct pilot or combustion flame monitoring, record indicating the presence of a pilot or combustion flame and periods when the pilot or combustion flame is absent.

(G) For each instance where there is a deviation of the control device in accordance with § 60.5417b(i)(6)(i) through (v), the date and time the deviation began, the duration of the deviation in hours, and cause of the deviation.

(H) Any additional information required to be recorded as specified by the Administrator as part of the alternative test method approval under § 60.5412b(d).

(12) For each closed vent system routing to a control device or process, the records of the assessment conducted according to § 60.5411b(c):

(i) A copy of the assessment conducted according to § 60.5411b(c)(1); and

(ii) A copy of the certification according to § 60.5411b(c)(1)(i) and (ii).

(13) A copy of each performance test submitted under paragraphs (b)(12) or (13) of this section.

(14) For the fugitive emissions components affected facility, maintain the records identified in paragraphs (c)(14)(i) through (viii) of this section.

(i) The date of the startup of production or the date of the first day of production after modification for the fugitive emissions components affected facility at a well site and the date of startup or the date of modification for the fugitive emissions components affected facility at a compressor station.

(ii) For the fugitive emissions components affected facility at a well site, you must maintain records specifying what type of well site it is (*i.e.*, single wellhead only well site, small wellsite, multi-wellhead only well site, or a well site with major production and processing equipment.)

(iii) For the fugitive emissions components affected facility at a well site where you complete the removal of all major production and processing equipment such that the well site contains only one or more wellheads, record the date the well site completes the removal of all major production and processing equipment from the well site, and, if the well site is still producing, record the well ID or separate tank battery ID receiving the production from the well site. If major production and processing equipment is subsequently added back to the well site, record the date that the first piece of major production and processing equipment is added back to the well site.

(iv) The fugitive emissions monitoring plan as required in § 60.5397b(b), (c), and (d).

(v) The records of each monitoring survey as specified in paragraphs (c)(14)(v)(A) through (I) of this section.

(A) Date of the survey.

(B) Beginning and end time of the survey.

(C) Name of operator(s), training, and experience of the operator(s) performing the survey.

(D) Monitoring instrument or method used.

(E) Fugitive emissions component identification when Method 21 of appendix A-7 to this part is used to perform the monitoring survey.

(F) Ambient temperature, sky conditions, and maximum wind speed at the time of the survey. For compressor stations, operating mode of

each compressor (*i.e.*, operating, standby pressurized, and not operating-depressurized modes) at the station at the time of the survey.

(G) Any deviations from the monitoring plan or a statement that there were no deviations from the monitoring plan.

(H) Records of calibrations for the instrument used during the monitoring survey.

(I) Documentation of each fugitive emission detected during the monitoring survey, including the information specified in paragraphs (c)(14)(v)(I)(1) through (9) of this section.

(1) Location of each fugitive emission identified.

(2) Type of fugitive emissions component, including designation as difficult-to-monitor or unsafe-to-monitor, if applicable.

(3) If Method 21 of appendix A-7 to this part is used for detection, record the component ID and instrument reading.

(4) For each repair that cannot be made during the monitoring survey when the fugitive emissions are initially found, a digital photograph or video must be taken of that component or the component must be tagged for identification purposes. The digital photograph must include the date that the photograph was taken and must clearly identify the component by location within the site (*e.g.*, the latitude and longitude of the component or by other descriptive landmarks visible in the picture). The digital photograph or identification (*e.g.*, tag) may be removed after the repair is completed, including verification of repair with the resurvey.

(5) The date of first attempt at repair of the fugitive emissions component(s).

(6) The date of successful repair of the fugitive emissions component, including the resurvey to verify repair and instrument used for the resurvey.

(7) Identification of each fugitive emission component placed on delay of repair and explanation for each delay of repair.

(8) For each fugitive emission component placed on delay of repair for reason of replacement component unavailability, the operator must document: the date the component was added to the delay of repair list, the date the replacement fugitive component or part thereof was ordered, the anticipated component delivery date (including any estimated shipment or delivery date provided by the vendor), and the actual arrival date of the component.

(9) Date of planned shutdowns that occur while there are any components that have been placed on delay of repair.

(vi) For the fugitive emissions components affected facility complying with an alternative means of emissions limitation under § 60.5399b, you must maintain the records specified by the specific alternative fugitive emissions standard for a period of at least 5 years.

(vii) For well closure activities, you must maintain the information specified in paragraphs (c)(14)(vii)(A) through (G) of this section.

(A) The well closure plan developed in accordance with § 60.5397b(l) and the date the plan was submitted.

(B) The notification of the intent to close the well site and the date the notification was submitted.

(C) The date of the cessation of production from all wells at the well site.

(D) The date you began well closure activities at the well site.

(E) Each status report for the well closure activities reported in paragraph (b)(9)(iv)(A) of this section.

(F) Each OGI survey reported in paragraph (b)(9)(iv)(B) of this section including the date, the monitoring instrument used, and the results of the survey or resurvey.

(G) The final OGI survey video demonstrating the closure of all wells at the site. The video must include the date that the video was taken and must identify the well site location by latitude and longitude.

(viii) If you comply with an alternative GHG and VOC standard under § 60.5398b, in lieu of the information specified in paragraphs (c)(14)(iv) and (v) of this section, you must maintain the records specified in § 60.5424b.

(15) For each pump affected facility, you must maintain the records identified in paragraphs (c)(15)(i) through (ix) of this section.

(i) Identification of each pump that is driven by natural gas and that is in operation 90 days or more per calendar year.

(ii) If you are complying with § 60.5393b(a) or (b)(1) by routing pump vapors to a process through a closed vent system, identification of all the pumps in the pump affected facility for which you collect and route vapors to a process through a closed vent system and the records specified in paragraphs (c)(8), (10), and (12) of this section. If you comply with an alternative GHG and VOC standard under § 60.5398b, in lieu of the information specified in paragraph (c)(8) of this section, you must provide the information specified in § 60.5424b.

(iii) If you are complying with § 60.5393b(b)(1) by routing pump vapors to control device achieving a 95.0

percent reduction in methane and VOC emissions, you must keep the records specified in paragraphs (c)(8) and (10) through (c)(13) of this section. If you comply with an alternative GHG and VOC standard under § 60.5398b, in lieu of the information specified in paragraph (c)(8) of this section, you must provide the information specified in § 60.5424b.

(iv) If you are complying with § 60.5393b(b)(3) by routing pump vapors to control device achieving less than a 95.0 percent reduction in methane and VOC emissions, you must maintain records of the certification that there is a control device on site but it does not achieve a 95.0 percent emissions reduction and a record of the design evaluation or manufacturer's specifications which indicate the percentage reduction the control device is designed to achieve.

(v) If you have less than three natural gas-driven diaphragm pumps in the pump affected facility, and you do not have a vapor recovery unit or control device installed on site by the compliance date, you must retain a record of your certification required under § 60.5393b(b)(4), certifying that there is no vapor recovery unit or control device on site. If you subsequently install a control device or vapor recovery unit, you must maintain the records required under paragraphs (c)(15)(ii), (iii) or (iv) of this section, as applicable.

(vi) If you determine, through an engineering assessment, that it is technically infeasible to route the pump affected facility emissions to a process or control device, you must retain records of your demonstration and certification that it is technically infeasible as required under § 60.5393b(b)(5).

(vii) If the pump is routed to a control device that is subsequently removed from the location or is no longer available such that there is no option to route to a control device, you are required to retain records of this change and the records required under paragraph (c)(15)(vi) of this section.

(viii) Records of each change in compliance method, including identification of each natural gas-driven pump which changes its method of compliance, the new method of compliance, and the date of the change in compliance method.

(ix) Records of each deviation, the date and time the deviation began, the duration of the deviation, and a description of the deviation.

(d) *Electronic reporting.* If you are required to submit notifications or reports following the procedure

specified in this paragraph (d), you must submit notifications or reports to the EPA via CEDRI, which can be accessed through the EPA's Central Data Exchange (CDX) (<https://cdx.epa.gov/>). The EPA will make all the information submitted through CEDRI available to the public without further notice to you. Do not use CEDRI to submit information you claim as CBI. Although we do not expect persons to assert a claim of CBI, if you wish to assert a CBI claim for some of the information in the report or notification, you must submit a complete file in the format specified in this subpart, including information claimed to be CBI, to the EPA following the procedures in paragraphs (g)(1) and (2) of this section. Clearly mark the part or all of the information that you claim to be CBI. Information not marked as CBI may be authorized for public release without prior notice. Information marked as CBI will not be disclosed except in accordance with procedures set forth in 40 CFR part 2. All CBI claims must be asserted at the time of submission. Anything submitted using CEDRI cannot later be claimed CBI. Furthermore, under CAA section 114(c), emissions data is not entitled to confidential treatment, and the EPA is required to make emissions data available to the public. Thus, emissions data will not be protected as CBI and will be made publicly available. You must submit the same file submitted to the CBI office with the CBI omitted to the EPA via the EPA's CDX as described earlier in this paragraph (d).

(1) The preferred method to receive CBI is for it to be transmitted electronically using email attachments, File Transfer Protocol, or other online file sharing services. Electronic submissions must be transmitted directly to the OAQPS CBI Office at the email address oaqpscbi@epa.gov, and as described above, should include clear CBI markings. ERT files should be flagged to the attention of the Group Leader, Measurement Policy Group; all other files should be flagged to the attention of the Oil and Natural Gas Sector Lead. If assistance is needed with submitting large electronic files that exceed the file size limit for email attachments, and if you do not have your own file sharing service, please email oaqpscbi@epa.gov to request a file transfer link.

(2) If you cannot transmit the file electronically, you may send CBI information through the postal service to the following address: U.S. EPA, Attn: OAQPS Document Control Officer, Mail Drop: C404-02, 109 T.W. Alexander Drive, P.O. Box 12055, RTP, NC 27711. ERT files should be sent to

the secondary attention of the Group Leader, Measurement Policy Group, and all other files should be sent to the secondary attention of the Oil and Natural Gas Sector Lead. The mailed CBI material should be double wrapped and clearly marked. Any CBI markings should not show through the outer envelope.

(e) *Claims of EPA system outage.* If you are required to electronically submit a notification or report through CEDRI in the EPA's CDX, you may assert a claim of EPA system outage for failure to timely comply with that requirement. To assert a claim of EPA system outage, you must meet the requirements outlined in paragraphs (e)(1) through (7) of this section.

(1) You must have been or will be precluded from accessing CEDRI and submitting a required report within the time prescribed due to an outage of either the EPA's CEDRI or CDX systems.

(2) The outage must have occurred within the period of time beginning five business days prior to the date that the submission is due.

(3) The outage may be planned or unplanned.

(4) You must submit notification to the Administrator in writing as soon as possible following the date you first knew, or through due diligence should have known, that the event may cause or has caused a delay in reporting.

(5) You must provide to the Administrator a written description identifying:

(i) The date(s) and time(s) when CDX or CEDRI was accessed and the system was unavailable;

(ii) A rationale for attributing the delay in reporting beyond the regulatory deadline to EPA system outage;

(iii) A description of measures taken or to be taken to minimize the delay in reporting; and

(iv) The date by which you propose to report, or if you have already met the reporting requirement at the time of the notification, the date you reported.

(6) The decision to accept the claim of EPA system outage and allow an extension to the reporting deadline is solely within the discretion of the Administrator.

(7) In any circumstance, the report must be submitted electronically as soon as possible after the outage is resolved.

(f) *Claims of force majeure.* If you are required to electronically submit a report or notification through CEDRI in the EPA's CDX, you may assert a claim of *force majeure* for failure to timely comply with that requirement. To assert a claim of *force majeure*, you must meet

the requirements outlined in paragraphs (f)(1) through (5) of this section.

(1) You may submit a claim if a *force majeure* event is about to occur, occurs, or has occurred or there are lingering effects from such an event within the period of time beginning five business days prior to the date the submission is due. For the purposes of this section, a *force majeure* event is defined as an event that will be or has been caused by circumstances beyond the control of the affected facility, its contractors, or any entity controlled by the affected facility that prevents you from complying with the requirement to submit a report electronically within the time period prescribed. Examples of such events are acts of nature (*e.g.*, hurricanes, earthquakes, or floods), acts of war or terrorism, or equipment failure or safety hazard beyond the control of the affected facility (*e.g.*, large scale power outage).

(2) You must submit notification to the Administrator in writing as soon as possible following the date you first knew, or through due diligence should have known, that the event may cause or has caused a delay in reporting.

(3) You must provide to the Administrator:

- (i) A written description of the *force majeure* event;
- (ii) A rationale for attributing the delay in reporting beyond the regulatory deadline to the *force majeure* event;
- (iii) A description of measures taken or to be taken to minimize the delay in reporting; and
- (iv) The date by which you propose to report, or if you have already met the reporting requirement at the time of the notification, the date you reported.

(4) The decision to accept the claim of *force majeure* and allow an extension to the reporting deadline is solely within the discretion of the Administrator.

(5) In any circumstance, the reporting must occur as soon as possible after the *force majeure* event occurs.

§ 60.5421b What are my additional recordkeeping requirements for process unit equipment affected facilities?

You must maintain a record of each equipment leak monitoring inspection and each leak identified under § 60.5400b and § 60.5401b as specified in paragraphs (b)(1) through (16) of this section. The record must be maintained either onsite or at the nearest local field office for at least 5 years. Any records required to be maintained that are submitted electronically via the EPA's CEDRI may be maintained in electronic format. This ability to maintain electronic copies does not affect the

requirement for facilities to make records, data, and reports available upon request to a delegated air agency or the EPA as part of an on-site compliance evaluation.

(a) You may comply with the recordkeeping requirements for multiple process unit equipment affected facilities in one recordkeeping system if the system identifies each record by each facility.

(b) You must maintain the monitoring inspection records specified in paragraphs (b)(1) through (16) of this section.

(1) Equipment Identification. Note that connectors need not be individually identified if all connectors in a designated area or length of pipe subject to the provisions of this subpart are identified as a group, and the number of connectors subject is indicated.

(2) Date and start and end times of the monitoring inspection.

(3) Inspector name.

(4) Leak determination method used for the monitoring inspection (*i.e.*, OGI, Method 21, or AVO).

(5) Monitoring instrument identification (OGI and Method 21 only).

(6) Type of equipment monitored.

(7) Process unit identification.

(8) The records specified in Section 12 of appendix K of this part, for each monitoring inspection conducted with OGI.

(9) The records in paragraph (b)(9)(i) through (vii), for each monitoring inspection conducted with Method 21 of appendix A-7 to this part.

(i) Instrument reading.

(ii) Date and time of instrument calibration and initials of operator performing the calibration.

(iii) Calibration gas cylinder identification, certification date, and certified concentration.

(iv) Instrument scale used.

(v) A description of any corrective action taken if the meter readout could not be adjusted to correspond to the calibration gas value in accordance with section 10.1 of Method 21 of appendix A-7 to this part.

(vi) Results of the daily calibration drift assessment.

(vii) If you make your own calibration gas, a description of the procedure used.

(10) For visual inspections of pumps in light liquid service, keep the records specified in paragraphs (b)(10)(i) through (iii), for each monitored equipment:

(i) Date of inspection.

(ii) Inspector name.

(iii) Result of inspection (*i.e.*, visual indications of liquids dripping from the pump seal or no visual indications of liquids dripping from the pump seal).

(11) For each leak detected, the records specified in paragraphs (b)(11)(i) through (v) of this section:

(i) The instrument and operator identification numbers and the process unit and equipment identification numbers. For leaks identified via AVO methods, enter the specific sensory method for instrument identification number.

(ii) The date the leak was detected.

(iii) For each attempt to repair the leak, record:

(A) The date.

(B) The repair method applied.

(C) Indication of whether a leak was still detected following each attempt to repair the leak.

(vi) The date of successful repair of the leak and the method of monitoring used to confirm the repair, as specified in paragraph (b)(11)(vi)(A) through (C) of this section.

(A) If Method 21 of appendix A-7 to this part is used to confirm the repair, maintain a record of the maximum instrument reading measured by Method 21 of appendix A-7 to this part.

(B) If OGI conducted in accordance with appendix K of this part is used to confirm the repair, maintain a record of video footage of the repair confirmation.

(C) If the leak is repaired by eliminating AVO indications of a leak, maintain a record of the specific sensory method used to confirm that the evidence of the leak is eliminated.

(v) For each repair delayed beyond 15 calendar days after detection of the leak, record:

(A) "Repair delayed" and the reason for the delay.

(B) The signature of the certifying official who made the decision that repair could not be completed without a process shutdown.

(C) The expected date of successful repair of the leak.

(D) Dates of process unit shutdowns that occur while the equipment is unrepaired.

(12) A list of identification numbers for equipment that are designated for no detectable emissions complying with the provisions of § 60.5401b.

(13) A list of identification numbers for valves, pumps, and connectors that are designated as unsafe-to-monitor, an explanation for each valve, pump, or connector stating why the valve, pump, or connector is unsafe-to-monitor, and the plan for monitoring each valve, pump, or connector.

(14) A list of identification numbers for valves that are designated as difficult-to-monitor, an explanation for each valve stating why the valve is difficult-to-monitor, and the schedule for monitoring each valve.

(15) A list of identification numbers for equipment that is in vacuum service.

(16) A list of identification numbers for equipment you designate as having the potential to emit methane or VOC less than 300 hr/yr.

(17) A list of identification numbers for valves where it was infeasible to replace leaking valves with low-e valves or repack existing valves with low-e packing technology, including the reasoning for why it was infeasible.

§ 60.5422b What are my additional reporting requirements for process unit equipment affected facilities?

(a) You must submit semiannual reports using the appropriate electronic report template on the CEDRI website for this subpart and following the procedure specified in § 60.5420b(d). If the reporting form specific to this subpart is not available on the CEDRI website at the time that the report is due, submit the report to the Administrator at the appropriate address listed in § 60.4. Once the form has been available on the CEDRI website for at least 90 calendar days, you must begin submitting all subsequent reports via CEDRI. The date reporting forms become available will be listed on the CEDRI website. Unless the Administrator or delegated state agency or other authority has approved a different schedule for submission of reports, the report must be submitted within 45 days after the end of the semiannual reporting period, regardless of the method in which the report is submitted.

(b) The initial semiannual report must include the following information:

(1) The general information specified in paragraph (c)(1) of this section.

(2) For each process unit:

(i) Process unit identification.

(ii) Number of valves subject to the monitoring requirements of §§ 60.5400b(b) and 60.5401b(f).

(iii) Number of pumps subject to the monitoring requirements of §§ 60.5400b(b) and 60.5401b(b).

(iv) Number of connectors subject to the monitoring requirements of §§ 60.5400b(b) and 60.5401b(h).

(v) Number of pressure relief devices subject to the monitoring requirements of §§ 60.5400b(b) and 60.5401b(c).

(vi) The information in paragraphs (c)(3) and (4) of this section.

(c) All subsequent semiannual reports must include the following information:

(1) The general information specified in paragraphs (c)(1)(i) through (iii) of this section.

(i) The company name, facility site name, and address of the affected facility.

(ii) Beginning and ending dates of the reporting period.

(iii) A certification by a certifying official of truth, accuracy, and completeness. This certification shall state that, based on information and belief formed after reasonable inquiry, the statements and information in the document are true, accurate, and complete. If your report is submitted via CEDRI, the certifier's electronic signature during the submission process replaces the requirement in this paragraph (c)(1)(iii).

(2) Process unit identification for each process unit.

(3) For each month during the semiannual reporting period for each process unit report:

(i) Number of valves for which leaks were detected as described in § 60.5400b(b) or § 60.5401b(f).

(ii) Number of valves for which leaks were not repaired as required in § 60.5400b(h) or § 60.5401b(i), the number of instances where it was technically infeasible to replace leaking valves with low-e valves or repack existing valves with low-e packing technology, including the reasoning for why it was technically infeasible.

(iii) Number of pumps for which leaks were detected as described in § 60.5400b(b) or § 60.5401b(b).

(iv) Number of pumps for which leaks were not repaired as required in § 60.5400b(h) or § 60.5401b(i).

(v) Number of connectors for which leaks were detected as described in § 60.5400b(b) or § 60.5401b(h).

(vi) Number of connectors for which leaks were not repaired as required in § 60.5400b(h) or § 60.5401b(i).

(vii) Number of pressure relief devices for which leaks were detected as described in § 60.5400b(b) or § 60.5401b(c).

(viii) Number of pressure relief devices for which leaks were not repaired as required in § 60.5400b(h) or § 60.5401b(i).

(ix) Number of open-ended valves or lines for which leaks were detected as described in § 60.5400b(e) or § 60.5401b(d).

(x) Number of open-ended valves or lines for which leaks were not repaired as required in § 60.5400b(h) or § 60.5401b(i).

(xi) Number of pumps, valves, or connectors in heavy liquid service or pressure relief device in light liquid or heavy liquid service for which leaks were detected as described in § 60.5400b(g) or § 60.5401b(g).

(xii) Number of pumps, valves, or connectors in heavy liquid service or pressure relief device in light liquid or heavy liquid service for which leaks

were not repaired as required in § 60.5400b(h) or § 60.5401b(i).

(xiii) The facts that explain each delay of repair and, where appropriate, why a process unit shutdown was technically infeasible.

(4) Dates of process unit shutdowns which occurred within the semiannual reporting period.

(5) Revisions to items reported according to paragraph (b) of this section if changes have occurred since the initial report or subsequent revisions to the initial report.

§ 60.5423b What are my additional recordkeeping and reporting requirements for sweetening unit affected facilities?

(a) You must retain records of the calculations and measurements required in §§ 60.5405b(a) and (b) and 60.5407b(a) through (g) for at least 2 years following the date of the measurements. This requirement is included under § 60.7(f) of the General Provisions.

(b) In your initial annual report submitted in accordance with the procedures and schedule in § 60.5420b(b), include the information in paragraphs (b)(1) and (2) of this section.

(1) For each run of the initial performance test required by § 60.8(b):

(i) The average sulfur feed rate in Mg/D, determined according to § 60.5406b(b).

(ii) The average volumetric flow rate of acid gas from the sweetening unit, in dscm/day.

(iii) The H₂S concentration in the acid gas feed from the sweetening unit, percent by volume.

(iv) The emission rate of sulfur in kg/hr.

(v) The sulfur production rate in kg/hr.

(vi) The emission reduction efficiency achieved by the sulfur recovery technology, determined according to § 60.5406b(c).

(vii) The required initial SO₂ emission reduction efficiency, as determined from table 3 to this subpart based on the sulfur feed rate and the sulfur content of the acid gas of the affected facility.

(2) The required minimum SO₂ emission reduction efficiency you must achieve on a continuous basis, as determined from table 4 to this subpart based on the sulfur feed rate and the sulfur content of the acid gas of the affected facility.

(c) You must submit the performance test report in accordance with the requirements of § 60.5420b(b)(12).

(d) You must submit a report of excess emissions to the Administrator in your annual report if you had excess

emissions during the reporting period. The procedures and schedule for submitting annual reports are located in § 60.5420b(b). For the purpose of these reports, excess emissions are defined as specified in paragraphs (d)(1) and (2) of this section. The report must contain the information specified in paragraph (d)(3) of this section.

(1) Any 24-hour period (at consistent intervals) during which the average sulfur emission reduction efficiency (R) is less than the minimum required efficiency (Z).

(2) For any affected facility electing to comply with the provisions of § 60.5407b(b)(2), any 24-hour period during which the average temperature of the gases leaving the combustion zone of an incinerator is less than the appropriate operating temperature as determined during the most recent performance test in accordance with the provisions of § 60.5407b(b)(3). Each 24-hour period must consist of at least 96 temperature measurements equally spaced over the 24 hours.

(3) For each period of excess emissions during the reporting period, include the following information in your report:

(i) The date and time of commencement and completion of each period of excess emissions;

(ii) The required minimum efficiency (Z) and the actual average sulfur emissions reduction (R) for periods defined in paragraph (d)(1) of this section; and

(iii) The appropriate operating temperature and the actual average temperature of the gases leaving the combustion zone for periods defined in paragraph (d)(2) of this section.

(e) To certify that a facility is exempt from the control requirements of these standards, for each facility with a design capacity less than 2 LT/D of H₂S in the acid gas (expressed as sulfur) you must keep, for the life of the facility, an analysis demonstrating that the facility's design capacity is less than 2 LT/D of H₂S expressed as sulfur.

(f) If you elect to comply with § 60.5407b(e) you must keep, for the life of the facility, a record demonstrating that the facility's design capacity is less than 150 LT/D of H₂S expressed as sulfur.

(g) The requirements of paragraph (d) of this section remain in force until and unless the EPA, in delegating enforcement authority to a state under section 111(c) of the Act, approves reporting requirements or an alternative means of compliance surveillance adopted by such state. In that event, affected sources within the state will be relieved of obligation to comply with

paragraph (d) of this section, provided they comply with the requirements established by the state. Electronic reporting to the EPA cannot be waived, and as such, the provisions of this paragraph do not relieve owners or operators of affected facilities of the requirement to submit the electronic reports required in this section to the EPA.

§ 60.5424b What are my additional recordkeeping and reporting requirements if I comply with the alternative GHG and VOC standards for fugitive emissions components affected facilities and covers and closed vent systems?

This section provides notification, reporting, and recordkeeping requirements for owners and operators who choose to comply with an alternative GHG and VOC standard as specified in § 60.5398b for fugitive emissions components affected facilities and the alternative continuous inspection and monitoring requirements for covers and closed vent systems. You must submit an annual report in accordance with the schedule in § 60.5420b(b) which includes the information in paragraphs (a)(1), (b), and (d) of this section, as applicable. You must submit the notification in paragraph (a)(2) of this section and maintain the records in paragraphs (c) and (e) of this section, as applicable.

(a) *Notifications.* If you choose to comply with an alternative GHG and VOC standard as specified in § 60.5398b for fugitive emissions components affected facilities and the alternative continuous inspection and monitoring requirements for covers and closed vent systems, you must submit the notification in paragraph (a)(1) of this section. If you are required by § 60.5398b(c)(8) to develop a mass emission rate reduction plan, you must submit the notification in paragraph (a)(2) of this section.

(1) A notification to the Administrator of adoption of the alternative standards in the annual report required by § 60.5420b(b)(4) through (11).

(2) A notification, which includes the submittal of the mass emission rate reduction plan required by § 60.5398b(c)(8). You must submit the mass emission rate reduction plan to the Administrator within 60 days of the initial exceedance of the action level.

(b) *Information submittal.* If you comply with the periodic screening requirements of § 60.5398b(b), you must submit the information in paragraphs (b)(1) through (6) of this section in the annual report required by § 60.5420b(b)(4) through (11).

(1) Date of each periodic screening during the reporting period and date

that results of the periodic screening were received.

(2) Alternative test method and technology used for each screening and the spatial resolution of the technology (*i.e.*, facility-level, area-level, or component-level).

(3) Any deviations from the monitoring plan developed under § 60.5398b(b)(2) or a statement that there were no deviations from the monitoring plan.

(4) Results from each periodic screening during the reporting period. If the results of the periodic screening indicate a confirmed detection of emissions from an affected facility, you must submit the information in paragraphs (b)(4)(i) through (iv) of this section.

(i) The date that the monitoring survey of your entire or the required portion of your fugitive emissions components affected facility was conducted.

(ii) The date that you completed the instrument inspections of all required covers and closed vent systems(s).

(iii) The date that you conducted the visual inspection for emissions of all required covers and closed vent systems.

(iv) For each fugitive emission from a fugitive emissions components affected facility and all emissions or defects of each cover and closed vent system, you must submit the information in paragraphs (b)(4)(iv)(A) through (D) of this section.

(A) Number and type of components for which fugitive emissions were detected.

(B) Each emission or defect identified during the inspection for each cover and closed vent system.

(C) Date of repair for each fugitive emission from a fugitive emissions components affected facility or each emission or defect for each cover and closed vent system.

(D) Number and type of fugitive emission components and identification of each cover or closed vent system placed on delay of repair and an explanation for each delay of repair.

(5) The information in paragraphs (b)(5)(i) through (iv) of this section if you are required to conduct OGI surveys in accordance with § 60.5398b(b)(1)(i) or if you replace a periodic screening event with an OGI survey in accordance with § 60.5398b(b)(1)(iv).

(i) The date of the OGI survey.

(ii) Number and type of components for which fugitive emissions were detected.

(iii) Number and type of fugitive emissions components that were not repaired as required in § 60.5397b(h).

(iv) Number and type of fugitive emission components placed on delay of repair and an explanation for each delay of repair.

(6) Any additional information regarding the performance of the periodic screening technology as specified by the Administrator, as part of the alternative test method approval described in § 60.5398b(d).

(c) *Maintain records.* If you comply with the periodic screening requirements of § 60.5398b(b), you must maintain the records in paragraphs (c)(1) through (11) of this section in addition to the records as specified in § 60.5420b(c)(3) through (9) and (c)(14) and (15).

(1) The monitoring plan as required in § 60.5398b(b)(2).

(2) Date of each periodic screening and date that results of the periodic screening were received.

(3) Name of screening operator.

(4) Alternative test method and technology used for screening, as well as the aggregate detection threshold for the technology and the spatial resolution of the technology (*i.e.*, facility-level, area-level, or component-level).

(5) Records of calibrations for technology used during the screening if calibration is required by the alternative test method approved in accordance with § 60.5398b(d).

(6) Results from periodic screening. If the results of the periodic screening indicate a confirmed detection of emissions from an affected facility, you must maintain the records in paragraphs (c)(6)(i) through (v) of this section.

(i) The date of the inspection of the fugitive emissions components and inspection of covers and closed vent system, as specified in § 60.5398b(b)(5).

(ii) Name of operator(s) performing the survey or inspection.

(iii) For surveys and instrument inspections, identification of the monitoring instrument(s) used.

(iv) Records of calibrations for the instrument(s) used during the survey or instrument inspection, as applicable.

(v) For each fugitive emission from a fugitive emissions components affected facility and each leak or defect for each cover and closed vent system inspection, you must maintain the records in paragraphs (c)(6)(v)(A) through (F) of this section.

(A) The location of the fugitive emissions identified using a unique identifier for the source of the emissions and the type of fugitive emissions component.

(B) The location of the emission or defect from a cover or closed vent

system using a unique identifier for the source of the emission or defect.

(C) If a defect of a closed vent system, cover, or control device is identified, a description of the defect.

(D) The date of repair for each fugitive emission from a fugitive emissions components affected facility or each emission or defect for each cover and closed vent system.

(E) Number and type of fugitive emission components and identification of each cover or closed vent system placed on delay of repair and an explanation for each delay of repair.

(F) For each fugitive emission component placed on delay of repair for reason of replacement component unavailability, the operator must document: the date the component was added to the delay of repair list, the date the replacement fugitive component or part thereof was ordered, the anticipated component delivery date (including any estimated shipment or delivery date provided by the vendor), and the actual arrival date of the component.

(7) The date the investigative analysis was initiated, and the result of the investigative analysis conducted in accordance with § 60.5398b(b)(5)(vi) and (vii), as applicable.

(8) Dates of implementation and completion of action(s) taken as a result of the investigative analysis and a description of the action(s) taken in accordance with § 60.5398b(b)(5)(vi) and (vii), as applicable.

(9) The information in paragraphs (c)(9)(i) through (vii) of this section if you are required to conduct OGI surveys in accordance with § 60.5398b(b)(1)(i) or if you replace a periodic screening event with an OGI survey in accordance with § 60.5398b(b)(1)(iv).

(i) The date of the OGI survey.

(ii) Location of each fugitive emission identified.

(iii) Type of fugitive emissions component for which fugitive emissions were detected.

(iv) The date of first attempt at repair of the fugitive emissions component(s).

(v) The date of successful repair of the fugitive emissions component(s), including the resurvey to verify the repair.

(vi) Identification of each fugitive emissions component placed on delay of repair and an explanation for each delay of repair.

(vii) For each fugitive emission component placed on delay of repair for reason of replacement component unavailability, the operator must document: the date the component was added to the delay of repair list, the date the replacement fugitive component or part thereof was ordered, the anticipated

component delivery date (including any estimated shipment or delivery date provided by the vendor), and the actual arrival date of the component.

(10) Any deviations from the monitoring plan or a statement that there were no deviations from the monitoring plan.

(11) All records required by the alternative approved in accordance with § 60.5398b(d).

(d) *Information submittal.* If you comply with the continuous monitoring system requirements of § 60.5398b(c), you must submit the information in paragraphs (d)(1) through (6) of this section in the annual report required by § 60.5420b(b)(4) through (11).

(1) The start date and end date for each period where the emissions rate determined in accordance with § 60.5398b(c)(6) exceeded one of the action levels determined in accordance with § 60.5398b(c)(4). Include which action level was exceeded (the 7-day or 90-day rolling average), the numerical value of the action level, and the mass emission rate calculated by the continuous monitoring system in the report.

(2) The date the investigative analysis was initiated, and the result of the investigative analysis conducted in accordance with § 60.5398b(c)(7), as applicable.

(3) Dates of implementation and completion of action(s) taken to reduce the mass emission rate and a description of the action(s) taken in accordance with § 60.5398b(c)(7), as applicable.

(4) If there are no instances reported under paragraph (d)(1) of this section, report your numerical action levels and the highest 7-day rolling average and highest 90-day rolling average determined by your continuous monitoring system during the reporting period.

(5) The start date for each instance where the 12-month rolling average operational downtime of the system exceeded 10 percent and the value of the 12-month rolling average operational downtime during the period. If there were no instances during the reporting period where the 12-month rolling average operational downtime of the system exceeded 10 percent, report the highest value of the 12-month rolling average operational downtime during the reporting period.

(6) Any additional information regarding the performance of the continuous monitoring system as specified by the Administrator, as part of the alternative test method approval described in § 60.5398b(d).

(e) *Maintain records.* If you comply with the continuous monitoring system

requirements of § 60.5398b(c), you must maintain the records in paragraphs (e)(1) through (15) of this section.

(1) The monitoring plan required by § 60.5398b(c)(2).

(2) Date of commencement of continuous monitoring with your continuous monitoring system.

(3) The detection threshold of the continuous monitoring system.

(4) The results of checks for power and function in accordance with § 60.5398b(c)(1)(ii).

(5) The beginning and end of each period of operational downtime for the system.

(6) Each rolling 12-month average operational downtime for the system, calculated in accordance with § 60.5398b(c)(1)(ii)(D).

(7) The 7-day rolling average and 90-day rolling average action levels for the site determined in accordance with § 60.5398b(c)(4).

(8) The information in paragraphs (e)(8)(i) through (v) of this section each time you establish site-specific baseline emissions in accordance with § 60.5398b(c)(5).

(i) Records of inspections of fugitive emissions components, covers, and closed vent systems required by § 60.5398b(c)(5)(i), including the date of inspection, location of each emission or defect identified, date of successful repair of each fugitive emissions component, cover, or closed vent system.

(ii) Records of inspections of control devices required by § 60.5398b(c)(5)(ii), including the date of the inspection and the results of the inspection.

(iii) The start date and time and end date and time of any maintenance activities that occurred during the 30 operating day period.

(iv) The site-level emission rate for each day during the 30 operating day period.

(v) The calculated site-specific baseline emission rate.

(9) Each methane mass emission rate reading determined by the system.

(10) Each daily, 7-day, and 90-day average mass emission rate which was determined in accordance with § 60.5398b(c)(6). If you exceed the 90-day action level, you must also keep records of the 30-day average mass emission rate following completion of the initial actions to reduce the average mass emission rate, in accordance with § 60.5398b(c)(8)(i).

(11) The results of each comparison of the emissions rate determined in accordance with § 60.5398b(c)(6) to the action level determined in accordance with § 60.5398b(c)(4).

(12) The date the investigative analysis was initiated, and the result of

the investigative analysis conducted in accordance with § 60.5398b(c)(7), as applicable.

(13) Dates of implementation and completion of action(s) taken to reduce the mass emission rate below the action level and a description of the action(s) taken in accordance with § 60.5398b(c)(7), as applicable.

(14) Each mass emission rate reduction plan developed in accordance with § 60.5398b(c)(8), as applicable. You must keep records of the actions taken in accordance with the plan and the date such actions are taken.

(15) Any additional information regarding the performance of the continuous monitoring technology as specified by the Administrator, as part of the alternative test method approval described in § 60.5398b(d).

§ 60.5425b What parts of the General Provisions apply to me?

Table 5 to this subpart shows which parts of the General Provisions in §§ 60.1 through 60.19 apply to you.

§ 60.5430b What definitions apply to this subpart?

As used in this subpart, all terms not defined herein shall have the meaning given them in the Act or in subpart A of this part; and the following terms shall have the specific meanings given them.

Access to electrical power means commercial line power is available onsite, with sufficient capacity to support the required power loading of onsite equipment, and which provides reliable and consistent power.

Acid gas means a gas stream of hydrogen sulfide (H₂S) and carbon dioxide (CO₂) that has been separated from sour natural gas by a sweetening unit.

Alaskan North Slope means the approximately 69,000 square-mile area extending from the Brooks Range to the Arctic Ocean.

API Gravity means the weight per unit volume of hydrocarbon liquids as measured by a system recommended by the American Petroleum Institute (API) and is expressed in degrees.

Artificial lift equipment means mechanical pumps including, but not limited to, rod pumps and electric submersible pumps used to flowback fluids from a well.

Associated gas means the natural gas from wells operated primarily for oil production that is released from the liquid hydrocarbon during the initial stage of separation after the wellhead. Associated gas production begins at the startup of production after the flow back period ends. Gas from wildcat or delineation wells is not associated gas.

Average aggregate detection threshold means:

(1) For the purposes of § 60.5398b, the average of all site-level detection thresholds from a single deployment (e.g., a singular flight that surveys multiple well sites, centralized production facility, and/or compressor stations) of a technology; and

(2) For the purposes of § 60.5371b, the average of all site-level detection thresholds from a single deployment in the same basin and field.

Bleed rate means the rate in standard cubic feet per hour at which natural gas is continuously vented (bleeds) from a process controller.

Capital expenditure means, as an alternative to the definition in 40 CFR 60.2, an expenditure for a physical or operational change to an existing facility that:

(1) Exceeds P, the product of the facility's replacement cost, R, and an adjusted annual asset guideline repair allowance, A, as reflected by the following equation: $P = R \times A$, where:

(i) The adjusted annual asset guideline repair allowance, A, is the product of the percent of the replacement cost, Y, and the applicable basic annual asset guideline repair allowance, B, divided by 100 as reflected by the following equation: $A = Y \times (B \div 100)$;

(ii) The percent Y is determined from the following equation: $Y = (\text{CPI of date of construction}/\text{most recently available CPI of date of project})$, where the "CPI-U, U.S. city average, all items" must be used for each CPI value; and

(iii) The applicable basic annual asset guideline repair allowance, B, is 4.5.

(2) [Reserved]

Centralized production facility means one or more storage vessels and all equipment at a single surface site used to gather, for the purpose of sale or processing to sell, crude oil, condensate, produced water, or intermediate hydrocarbon liquid from one or more offsite natural gas or oil production wells. This equipment includes, but is not limited to, equipment used for storage, separation, treating, dehydration, artificial lift, combustion, compression, pumping, metering, monitoring, and flowline. Process vessels and process tanks are not considered storage vessels or storage tanks. A centralized production facility is located upstream of the natural gas processing plant or the crude oil pipeline breakout station and is a part of producing operations.

Centrifugal compressor means any machine for raising the pressure of a natural gas by drawing in low pressure natural gas and discharging significantly

higher-pressure natural gas by means of mechanical rotating vanes or impellers. Screw, sliding vane, and liquid ring compressors are not centrifugal compressors for the purposes of this subpart.

Centrifugal compressor equipped with sour seal oil separator and capture system means a wet seal centrifugal compressor system which has an intermediate closed process that degasses most of the gas entrained in the sour seal oil and sends that gas to either another process or combustion device (*i.e.*, degassed emissions are recovered). The de-gas emissions are routed back to a process or combustion device directly from the intermediate closed degassing process; after the intermediate closed process the oil is ultimately recycled for recirculation in the seals to the lube oil tank where any small amount of residual gas is released through a vent.

Certifying official means one of the following:

(1) For a corporation: A president, secretary, treasurer, or vice-president of the corporation in charge of a principal business function, or any other person who performs similar policy or decision-making functions for the corporation, or a duly authorized representative of such person if the representative is responsible for the overall operation of one or more manufacturing, production, or operating facilities with an affected facility subject to this subpart and either:

(i) The facilities employ more than 250 persons or have gross annual sales or expenditures exceeding \$25 million (in second quarter 1980 dollars); or

(ii) The Administrator is notified of such delegation of authority prior to the exercise of that authority. The Administrator reserves the right to evaluate such delegation;

(2) For a partnership (including but not limited to general partnerships, limited partnerships, and limited liability partnerships) or sole proprietorship: A general partner or the proprietor, respectively. If a general partner is a corporation, the provisions of paragraph (1) of this definition apply;

(3) For a municipality, state, Federal, or other public agency: Either a principal executive officer or ranking elected official. For the purposes of this part, a principal executive officer of a Federal agency includes the chief executive officer having responsibility for the overall operations of a principal geographic unit of the agency (*e.g.*, a Regional Administrator of EPA); or

(4) For affected facilities:

(i) The designated representative in so far as actions, standards, requirements, or prohibitions under title IV of the

CAA or the regulations promulgated thereunder are concerned; or

(ii) The designated representative for any other purposes under this part.

Closed vent system means a system that is not open to the atmosphere and that is composed of hard-piping, ductwork, connections, and, if necessary, flow-inducing devices that transport gas or vapor from a piece or pieces of equipment to a control device or back to a process.

Coil tubing cleanout means the process where an operator runs a string of coil tubing to the packed proppant within a well and jets the well to dislodge the proppant and provide sufficient lift energy to flow it to the surface. Coil tubing cleanout includes mechanical methods to remove solids and/or debris from a wellbore.

Collection system means any infrastructure that conveys gas or liquids from the well site to another location for treatment, storage, processing, recycling, disposal or other handling.

Completion combustion device means any ignition device, installed horizontally or vertically, used in exploration and production operations to combust otherwise vented emissions from completions. Completion combustion devices include pit flares.

Compressor mode means the operational and pressurized status of a compressor. For both centrifugal compressors and reciprocating compressors, "mode" refers to either: Operating-mode, standby-pressurized-mode, or not-operating-depressurized-mode.

Compressor station means any permanent combination of one or more compressors that move natural gas at increased pressure through gathering or transmission pipelines, or into or out of storage. This includes but is not limited to gathering and boosting stations and transmission compressor stations. The combination of one or more compressors located at a well site, centralized production facility, or an onshore natural gas processing plant, is not a compressor station for purposes of § 60.5365b(e) and § 60.5397b.

Condensate means hydrocarbon liquid separated from natural gas that condenses due to changes in the temperature, pressure, or both, and remains liquid at standard conditions.

Connector means flanged, screwed, or other joined fittings used to connect two pipe lines or a pipe line and a piece of process equipment or that close an opening in a pipe that could be connected to another pipe. Joined fittings welded completely around the circumference of the interface are not

considered connectors for the purpose of this regulation.

Continuous bleed means a continuous flow of pneumatic supply natural gas to a process controller.

Crude oil and natural gas source category means:

(1) Crude oil production, which includes the well and extends to the point of custody transfer to the crude oil transmission pipeline or any other forms of transportation; and

(2) Natural gas production, processing, transmission, and storage, which include the well and extend to, but do not include, the local distribution company custody transfer station.

Custody meter means the meter where natural gas or hydrocarbon liquids are measured for sales, transfers, and/or royalty determination.

Custody meter assembly means an assembly of fugitive emissions components, including the custody meter, valves, flanges, and connectors necessary for the proper operation of the custody meter.

Custody transfer means the transfer of crude oil or natural gas after processing and/or treatment in the producing operations, or from storage vessels or automatic transfer facilities or other such equipment, including product loading racks, to pipelines or any other forms of transportation.

Dehydrator means a device in which an adsorbent directly contacts a natural gas stream and absorbs water in a contact tower or adsorption column (adsorber).

Delineation well means a well drilled in order to determine the boundary of a field or producing reservoir.

Deviation means any instance in which an affected source subject to this subpart, or an owner or operator of such a source:

(1) Fails to meet any requirement or obligation established by this subpart including, but not limited to, any emission limit, operating limit, or work practice standard;

(2) Fails to meet any term or condition that is adopted to implement an applicable requirement in this subpart and that is included in the operating permit for any affected source required to obtain such a permit; or

(3) Fails to meet any emission limit, operating limit, or work practice standard of this subpart during startup, shutdown, or malfunction, regardless of whether or not such failure is permitted by this subpart.

Distance piece means an open or enclosed casing through which the piston rod travels, separating the compressor cylinder from the crankcase.

Double block and bleed system means two block valves connected in series with a bleed valve or line that can vent the line between the two block valves.

Duct work means a conveyance system such as those commonly used for heating and ventilation systems. It is often made of sheet metal and often has sections connected by screw or crimping. Hard-piping is not ductwork.

Emergency shutdown device means a device which functions exclusively to protect personnel and/or prevent physical damage to equipment by shutting down equipment or gas flow during unsafe conditions resulting from an unexpected event, such as a pipe break or fire. For the purposes of this subpart, an emergency shutdown device is not used for routine control of operating conditions.

Equipment, as used in the standards and requirements of this subpart relative to the process unit equipment affected facility at onshore natural gas processing plants, means each pump, pressure relief device, open-ended valve or line, valve, and flange or other connector that has the potential to emit methane or VOC and any device or system required by those same standards and requirements of this subpart.

Field gas means feedstock gas entering the natural gas processing plant.

Field gas gathering means the system used transport field gas from a field to the main pipeline in the area.

First attempt at repair means an action taken for the purpose of stopping or reducing fugitive emissions to the atmosphere. First attempts at repair include, but are not limited to, the following practices where practicable and appropriate: Tightening bonnet bolts; replacing bonnet bolts; tightening packing gland nuts; or injecting lubricant into lubricated packing.

Flare means a thermal oxidation system using an open (without enclosure) flame. Completion combustion devices as defined in this section are not considered flares.

Flow line means a pipeline used to transport oil and/or gas to a processing facility or a mainline pipeline.

Flowback means the process of allowing fluids and entrained solids to flow from a well following a treatment, either in preparation for a subsequent phase of treatment or in preparation for cleanup and returning the well to production. The term flowback also means the fluids and entrained solids that emerge from a well during the flowback process. The flowback period begins when material introduced into the well during the treatment returns to

the surface following hydraulic fracturing or refracturing. The flowback period ends when either the well is shut in and permanently disconnected from the flowback equipment or at the startup of production. The flowback period includes the initial flowback stage and the separation flowback stage. Screenouts, coil tubing cleanouts, and plug drill-outs are not considered part of the flowback process.

Fuel gas means gases that are combusted to derive useful work or heat.

Fuel gas system means the offsite and onsite piping and flow and pressure control system that gathers gaseous stream(s) generated by onsite operations, may blend them with other sources of gas, and transports the gaseous stream for use as fuel gas in combustion devices or in-process combustion equipment, such as furnaces and gas turbines, either singly or in combination.

Fugitive emissions means, for the purposes of § 60.5397b, any indication of emissions observed from a fugitive emissions component using AVO, an indication of visible emissions observed from an OGI instrument, or an instrument reading of 500 ppmv or greater using Method 21 of appendix A-7 to this part.

Fugitive emissions component means any component that has the potential to emit fugitive emissions of methane or VOC at a well site, centralized production facility, or compressor station, such as valves (including separator dump valves), connectors, pressure relief devices, open-ended lines, flanges, covers and closed vent systems not subject to § 60.5411b, thief hatches or other openings on a storage vessel not subject to § 60.5395b, compressors, instruments, meters, and yard piping.

Gas to oil ratio (GOR) means the ratio of the volume of gas at standard temperature and pressure that is produced from a volume of oil when depressurized to standard temperature and pressure.

Hard-piping means pipe or tubing that is manufactured and properly installed using good engineering judgment and standards such as ASME B31.3, Process Piping (available from the American Society of Mechanical Engineers, P.O. Box 2300, Fairfield, NJ 07007-2300).

Hydraulic fracturing means the process of directing pressurized fluids containing any combination of water, proppant, and any added chemicals to penetrate tight formations, such as shale or coal formations, that subsequently require high rate, extended flowback to

expel fracture fluids and solids during completions.

Hydraulic refracturing means conducting a subsequent hydraulic fracturing operation at a well that has previously undergone a hydraulic fracturing operation.

In gas/vapor service means that the piece of equipment contains process fluid that is in the gaseous state at operating conditions.

In heavy liquid service means that the piece of equipment is not in gas/vapor service or in light liquid service.

In light liquid service means that the piece of equipment contains a liquid that meets the conditions specified in § 60.5402b(d)(2) or § 60.5403b.

In vacuum service means that equipment is operating at an internal pressure which is at least 5 kilopascals (kPa) (0.7 psia) below ambient pressure.

In wet gas service means that a compressor or piece of equipment contains or contacts the field gas before the extraction step at a gas processing plant process unit.

Initial calibration value as used in the standards and requirements of this subpart relative to the process unit equipment affected facility at onshore natural gas processing plants means the concentration measured during the initial calibration at the beginning of each day required in § 60.5403b, or the most recent calibration if the instrument is recalibrated during the day (*i.e.*, the calibration is adjusted) after a calibration drift assessment.

Initial flowback stage means the period during a well completion operation which begins at the onset of flowback and ends at the separation flowback stage.

Intermediate hydrocarbon liquid means any naturally occurring, unrefined petroleum liquid.

Intermittent vent natural gas-driven process controller means a process controller that is not designed to have a continuous bleed rate but is instead designed to only release natural gas to the atmosphere as part of the actuation cycle.

Liquefied natural gas unit means a unit used to cool natural gas to the point at which it is condensed into a liquid which is colorless, odorless, non-corrosive and non-toxic.

Liquid collection system means tankage and/or lines at a well site to contain liquids from one or more wells or to convey liquids to another site.

Liquids dripping means any visible leakage from the seal, including spraying, misting, clouding, and ice formation.

Liquids unloading means the unloading of liquids that have

accumulated over time in gas wells, which are impeding or halting production. Routine well maintenance activities, including workovers, screenouts, coil tubing cleanouts, or any other activity that requires a rig or other machinery are not considered liquids unloading.

Local distribution company (LDC) custody transfer station means a metering station where the LDC receives a natural gas supply from an upstream supplier, which may be an interstate transmission pipeline or a local natural gas producer, for delivery to customers through the LDC's intrastate transmission or distribution lines.

Low-e valve means a valve (including its specific packing assembly) for which the manufacturer has issued a written warranty or performance guarantee that it will not emit fugitives at greater than 100 ppm in the first five years. A valve may qualify as a low-e valve if it is as an extension of another valve that has qualified as a low-e valve.

Low-e packing means a valve packing product for which the manufacturer has issued a written warranty or performance guarantee that it will not emit fugitives at greater than 100 ppm in the first five years. Low-e injectable packing is a type of low-e packing product for which the manufacturer has also issued a written warranty or performance guarantee and that can be injected into a valve during a "drill-and-tap" repair of the valve.

Low pressure well means a well that satisfies at least one of the following conditions:

(1) The static pressure at the wellhead following fracturing but prior to the onset of flowback is less than the flow line pressure;

(2) The pressure of flowback fluid immediately before it enters the flow line, as determined under § 60.5432b, is less than the flow line pressure; or

(3) Flowback of the fracture fluids will not occur without the use of artificial lift equipment.

Major production and processing equipment means reciprocating or centrifugal compressors, glycol dehydrators, heater/treaters, separators, control devices, natural gas-driven process controllers, natural gas-driven pumps, and storage vessels or tank batteries collecting crude oil, condensate, intermediate hydrocarbon liquids, or produced water, for the purpose of determining whether a well site is a wellhead only well site.

Maximum average daily throughput means the following:

(1) The earliest calculation of daily average throughput, determined as described in paragraph (2) or (3) of this

definition, to a tank battery over the days that production is routed to that tank battery during the 30-day PTE evaluation period employing generally accepted methods specified in § 60.5365b(e)(2).

(2) If throughput to the tank battery is measured on a daily basis (e.g., via level gauge automation or daily manual gauging), the maximum average daily throughput is the average of all daily throughputs for days on which throughput was routed to the tank battery during the 30-day evaluation period; or

(3) If throughput to the tank battery is not measured on a daily basis (e.g., via manual gauging at the start and end of loadouts), the maximum average daily throughput is the highest, of the average daily throughputs, determined for any production period to that tank battery during the 30-day evaluation period, as determined by averaging total throughput to that tank battery over each production period. A production period begins when production begins to be routed to a tank battery and ends either when throughput is routed away from that tank battery or when a loadout occurs from that tank battery, whichever happens first. Regardless of the determination methodology, operators must not include days during which throughput is not routed to the tank battery when calculating maximum average daily throughput for that tank battery.

Multi-wellhead only well site means a well site that contains two or more wellheads and no major production and processing equipment.

Natural gas-driven diaphragm pump means a positive displacement pump powered by pressurized natural gas that uses the reciprocating action of flexible diaphragms in conjunction with check valves to pump a fluid. A pump in which a fluid is displaced by a piston driven by a diaphragm is not considered a diaphragm pump for purposes of this subpart. A lean glycol circulation pump that relies on energy exchange with the rich glycol from the contactor is not considered a diaphragm pump.

Natural gas-driven piston pump means a positive displacement pump powered by pressurized natural gas that moves and pressurizes fluid by using one or more reciprocating pistons. A pump in which a fluid is displaced by a piston driven by a diaphragm is considered a piston pump for purposes of this subpart. A lean glycol circulation pump that relies on energy exchange with the rich glycol from the contactor is not considered a piston pump.

Natural gas-driven process controller means a process controller powered by pressurized natural gas.

Natural gas liquids means the hydrocarbons, such as ethane, propane, butane, and pentane that are extracted from field gas.

Natural gas processing plant (gas plant) means any processing site engaged in the extraction of natural gas liquids from field gas, fractionation of mixed natural gas liquids to natural gas products, or both. A Joule-Thompson valve, a dew point depression valve, or an isolated or standalone Joule-Thompson skid is not a natural gas processing plant.

Natural gas transmission means the pipelines used for the long-distance transport of natural gas (excluding processing). Specific equipment used in natural gas transmission includes the land, mains, valves, meters, boosters, regulators, storage vessels, dehydrators, compressors, and their driving units and appurtenances, and equipment used for transporting gas from a production plant, delivery point of purchased gas, gathering system, storage area, or other wholesale source of gas to one or more distribution area(s).

No detectable emissions means, for the purposes of § 60.5401b and § 60.5403b, that the equipment is operating with an instrument reading of less than 500 ppmv above background, as determined by Method 21 of appendix A-7 to this part.

No identifiable emissions means, for the purposes of covers, closed vent systems, and self-contained natural gas-driven process controllers and as determined according to the provisions of § 60.5416b, that no emissions are detected by AVO means when inspections are conducted by AVO; no emissions are imaged with an OGI camera when inspections are conducted with OGI; and equipment is operating with an instrument reading of less than 500 ppmv above background, as determined by Method 21 of appendix A-7 to this part when inspections are conducted with Method 21.

Nonfractionating plant means any gas plant that does not fractionate mixed natural gas liquids into natural gas products.

Non-natural gas-driven process controller means an instrument that is actuated using other sources of power than pressurized natural gas; examples include solar, electric, and instrument air.

Onshore means all facilities except those that are located in the territorial seas or on the outer continental shelf.

Open-ended valve or line or open-ended vent line means any valves,

except safety relief valves, having one side of the valve seat in contact with process fluid and one side open to the atmosphere, either directly or through open piping.

Plug drill-out means the removal of a plug (or plugs) that was used to isolate different sections of the well.

Process controller means an automated instrument used for maintaining a process condition such as liquid level, pressure, delta-pressure and temperature.

Pressure release means the emission of materials resulting from system pressure being greater than set pressure of the pressure relief device.

Pressure vessel means a storage vessel that is used to store liquids or gases and is designed not to vent to the atmosphere as a result of compression of the vapor headspace in the pressure vessel during filling of the pressure vessel to its design capacity.

Pressurized mode means when the compressor contains natural gas that is maintained at a pressure higher than the atmospheric pressure.

Process improvement means routine changes made for safety and occupational health requirements, for energy savings, for better utility, for ease of maintenance and operation, for correction of design deficiencies, for bottleneck removal, for changing product requirements, or for environmental control.

Process unit means components assembled for the extraction of natural gas liquids from field gas, the fractionation of the liquids into natural gas products, or other operations associated with the processing of natural gas products. A process unit can operate independently if supplied with sufficient feed or raw materials and sufficient storage facilities for the products.

Process unit shutdown means a work practice or operational procedure that stops production from a process unit or part of a process unit during which it is technically feasible to clear process material from a process unit or part of a process unit consistent with safety constraints and during which repairs can be accomplished. The following are not considered process unit shutdowns:

(1) An unscheduled work practice or operational procedure that stops production from a process unit or part of a process unit for less than 24 hours.

(2) An unscheduled work practice or operational procedure that would stop production from a process unit or part of a process unit for a shorter period of time than would be required to clear the process unit or part of the process unit of materials and start up the unit, and

would result in greater emissions than delay of repair of leaking components until the next scheduled process unit shutdown.

(3) The use of spare equipment and technically feasible bypassing of equipment without stopping production.

Produced water means water that is extracted from the earth from an oil or natural gas production well, or that is separated from crude oil, condensate, or natural gas after extraction.

Qualified Professional Engineer means an individual who is licensed by a state as a Professional Engineer to practice one or more disciplines of engineering and who is qualified by education, technical knowledge, and experience to make the specific technical certifications required under this subpart. Professional engineers making these certifications must be currently licensed in at least one state in which the certifying official is located.

Quarter means a 3-month period. For purposes of standards for process unit equipment affected facilities at onshore natural gas processing plants, the first quarter concludes on the last day of the last full month during the 180 days following initial startup.

Reciprocating compressor means a piece of equipment that increases the pressure of a process gas by positive displacement, employing linear movement of the driveshaft.

Reciprocating compressor rod packing means a series of flexible rings in machined metal cups that fit around the reciprocating compressor piston rod to create a seal limiting the amount of compressed natural gas that escapes to the atmosphere, or other mechanism that provides the same function.

Recovered gas means gas recovered through the separation process during flowback.

Recovered liquids means any crude oil, condensate or produced water recovered through the separation process during flowback.

Reduced emissions completion means a well completion following fracturing or refracturing where gas flowback that is otherwise vented is captured, cleaned, and routed to the gas flow line or collection system, re-injected into the well or another well, used as an onsite fuel source, or used for other useful purpose that a purchased fuel or raw material would serve, with no direct release to the atmosphere.

Reduced sulfur compounds means H₂S, carbonyl sulfide (COS), and carbon disulfide (CS₂).

Removed from service means that a storage vessel affected facility has been

physically isolated and disconnected from the process for a purpose other than maintenance in accordance with § 60.5395b(c)(1).

Repaired means the following:

(1) For the purposes of fugitive emissions components affected facilities, that fugitive emissions components are adjusted, replaced, or otherwise altered, in order to eliminate fugitive emissions and resurveyed as specified in § 60.5397b(h)(4) and it is verified that emissions from the fugitive emissions components are below the applicable fugitive emissions definition.

(2) For the purposes of process unit equipment affected facilities, that equipment is adjusted, or otherwise altered, in order to eliminate a leak as defined in §§ 60.5400b and 60.5401b and is re-monitored as specified in § 60.5400b(b) introductory text and (b)(1) or § 60.5403b, respectively, to verify that emissions from the equipment are below the applicable leak definition. Pumps in light liquid service subject to § 60.5400b(c)(2) or § 60.5401b(b)(1)(ii) are not subject to re-monitoring.

Replacement cost means the capital needed to purchase all the depreciable components in a facility.

Returned to service means that a storage vessel affected facility that was removed from service has been:

(1) Reconnected to the original source of liquids or has been used to replace any storage vessel affected facility; or

(2) Installed in any location covered by this subpart and introduced with crude oil, condensate, intermediate hydrocarbon liquids or produced water.

Routed to a process or route to a process means the emissions are conveyed via a closed vent system to any enclosed portion of a process that is operational where the emissions are predominantly recycled and/or consumed in the same manner as a material that fulfills the same function in the process and/or transformed by chemical reaction into materials that are not regulated materials and/or incorporated into a product; and/or recovered.

Salable quality gas means natural gas that meets the flow line or collection system operator specifications, regardless of whether such gas is sold.

Screenout means an attempt to clear proppant from the wellbore to dislodge the proppant out of the well.

Self-contained process controller means a natural gas-driven process controller that releases gas into the downstream piping and not to the atmosphere, resulting in zero methane and VOC emissions.

Self-contained wet seal centrifugal compressor means:

(1) A wet seal centrifugal compressor system that is a closed process that ports the degassing emissions into the natural gas line at the compressor suction (*i.e.*, degassed emissions are recovered) or which has an intermediate closed process that degasses most of the gas entrained in the seal oil and sends that gas to another process. The de-gas emissions are routed back to suction or process directly from the closed or intermediate closed degassing process; after the closed or intermediate closed degassing process the oil is ultimately recycled for recirculation in the seals to the lube oil tank where any small amount of residual gas is released through a vent.

(2) A wet seal centrifugal compressor equipped with mechanical wet seals, where

(i) A differential pressure is maintained on the system and there is no off gassing of the lube oil, and

(ii) The mechanical seal is integrated into the compressor housing.

Sensor means a device that measures a physical quantity or the change in a physical quantity such as temperature, pressure, flow rate, pH, or liquid level.

Separation flowback stage means the period during a well completion operation when it is technically feasible for a separator to function. The separation flowback stage ends either at the startup of production, or when the well is shut in and permanently disconnected from the flowback equipment.

Separator dump valve means, for purposes of the fugitive emission standards in §§ 60.5397b and 60.5398b, a liquid-control valve in a separator that controls the liquid level within the separator vessel.

Single wellhead only well site means a wellhead only well site that contains only one wellhead and no major production and processing equipment.

Small well site means, for purposes of the fugitive emissions standards in §§ 60.5397b and 60.5398b, a well site that contains a single wellhead, no more than one piece of certain major production and processing equipment, and associated meters and yard piping. Small well sites cannot include any controlled storage vessels (or controlled tank batteries), control devices, natural gas-driven process controllers, or natural gas-driven pumps.

Startup of production means the beginning of initial flow following the end of flowback when there is continuous recovery of salable quality gas and separation and recovery of any crude oil, condensate, or produced

water, except as otherwise provided in this definition. For the purposes of the fugitive monitoring requirements of § 60.5397b, *startup of production* means the beginning of the continuous recovery of salable quality gas and separation and recovery of any crude oil, condensate, or produced water.

Storage vessel means a tank or other vessel that contains an accumulation of crude oil, condensate, intermediate hydrocarbon liquids, or produced water, and that is constructed primarily of nonearthen materials (such as wood, concrete, steel, fiberglass, or plastic) which provide structural support. A well completion vessel that receives recovered liquids from a well after startup of production following flowback for a period which exceeds 60 days is considered a storage vessel under this subpart. A tank or other vessel shall not be considered a storage vessel if it has been removed from service in accordance with the requirements of § 60.5395b(c)(1) until such time as such tank or other vessel has been returned to service. For the purposes of this subpart, the following are not considered storage vessels:

(1) Vessels that are skid-mounted or permanently attached to something that is mobile (such as trucks, railcars, barges or ships), and are intended to be located at a site for less than 180 consecutive days. If you do not keep or are not able to produce records, as required by § 60.5420b(c)(5)(iv), showing that the vessel has been located at a site for less than 180 consecutive days, the vessel described herein is considered to be a storage vessel from the date the original vessel was first located at the site. This exclusion does not apply to a well completion vessel as described above.

(2) Process vessels such as surge control vessels, bottoms receivers or knockout vessels.

(3) Pressure vessels designed to operate in excess of 204.9 kilopascals and without emissions to the atmosphere.

Sulfur production rate means the rate of liquid sulfur accumulation from the sulfur recovery unit.

Sulfur recovery unit means a process device that recovers element sulfur from acid gas.

Surface site means any combination of one or more graded pad sites, gravel pad sites, foundations, platforms, or the immediate physical location upon which equipment is physically affixed.

Sweetening unit means a process device that removes hydrogen sulfide and/or carbon dioxide from the sour natural gas stream.

Tank battery means a group of all storage vessels that are manifolded together for liquid transfer. A tank battery may consist of a single storage vessel if only one storage vessel is present.

Total Reduced Sulfur (TRS) means the sum of the sulfur compounds hydrogen sulfide, methyl mercaptan, dimethyl sulfide, and dimethyl disulfide as measured by Method 16 of appendix A–6 to this part.

Total SO₂ equivalents means the sum of volumetric or mass concentrations of the sulfur compounds obtained by adding the quantity existing as SO₂ to the quantity of SO₂ that would be obtained if all reduced sulfur compounds were converted to SO₂ (ppmv or kg/dscm (lb/dscf)).

UIC Class I oilfield disposal well means a well with a UIC Class I permit that meets the definition in 40 CFR 144.6(a)(2) and receives eligible fluids from oil and natural gas exploration and production operations.

UIC Class II oilfield disposal well means a well with a UIC Class II permit where wastewater resulting from oil and natural gas production operations is injected into underground porous rock formations not productive of oil or gas, and sealed above and below by unbroken, impermeable strata.

Underground storage vessel means a storage vessel stored below ground.

Well means a hole drilled for the purpose of producing oil or natural gas, or a well into which fluids are injected.

Well completion means the process that allows for the flowback of petroleum or natural gas from newly drilled wells to expel drilling and reservoir fluids and tests the reservoir flow characteristics, which may vent produced hydrocarbons to the atmosphere via an open pit or tank.

Well completion operation means any well completion with hydraulic fracturing or refracturing occurring at a well completion affected facility.

Well completion vessel means a vessel that contains flowback during a well completion operation following hydraulic fracturing or refracturing. A well completion vessel may be a lined earthen pit, a tank or other vessel that is skid-mounted or portable. A well completion vessel that receives recovered liquids from a well after startup of production following flowback for a period which exceeds 60 days is considered a storage vessel under this subpart.

Well site means one or more surface sites that are constructed for the drilling and subsequent operation of any oil well, natural gas well, or injection well. For the purposes of the fugitive

emissions standards at § 60.5397b, a well site does not include:

(1) UIC Class II oilfield disposal wells and disposal facilities;

(2) UIC Class I oilfield disposal wells; and

(3) The flange immediately upstream of the custody meter assembly and equipment, including fugitive emissions components, located downstream of this flange.

Wellhead means the piping, casing, tubing and connected valves protruding above the earth's surface for an oil and/or natural gas well. The wellhead ends where the flow line connects to a wellhead valve. The wellhead does not

include other equipment at the well site except for any conveyance through which gas is vented to the atmosphere.

Wellhead only well site means, for the purposes of the fugitive emissions standards at § 60.5397b and the standards in § 60.5398b, a well site that contains one or more wellheads and no major production and processing equipment.

Wildcat well means a well outside known fields or the first well drilled in an oil or gas field where no other oil and gas production exists.

Yard piping means hard-piping at a well site, centralized production

facility, or compressor station that is not part of a closed vent system.

§ 60.5432b How do I determine whether a well is a low pressure well using the low pressure well equation?

(a) To determine that your well is a low pressure well subject to § 60.5375b(f), you must determine whether the characteristics of the well are such that the well meets the definition of low pressure well in § 60.5430b. To determine that the well meets the definition of low pressure well in § 60.5430b, you must use the low pressure well equation:

Equation 1 to paragraph (a)

$$P_L \text{ (psia)} = 0.495 \times P_R - \frac{q_g}{q_g + q_o + q_w} [0.05 \times P_R + 0.038 \times L - 67.578] - \left[\frac{q_o}{q_g + q_o + q_w} \times \left(\frac{\rho_o}{144} + \frac{q_w}{q_g + q_o + q_w} \cdot 0.433 \right) \right] \cdot L$$

Where:

- (1) P_L is the pressure of flowback fluid immediately before it enters the flow line, expressed in pounds force per square inch (psia), and is to be calculated using the equation above;
- (2) P_R is the pressure of the reservoir containing oil, gas, and water at the well site, expressed in psia;
- (3) L is the true vertical depth of the well, expressed in feet (ft);

- (4) q_o is the flow rate of oil in the well, expressed in cubic feet/second (cu ft/sec);
- (5) q_g is the flow rate of gas in the well, expressed in cu ft/sec;
- (6) q_w is the flow rate of water in the well, expressed in cu ft/sec;
- (7) ρ_o is the density of oil in the well, expressed in pounds mass per cubic feet (lbm/cu ft).

(b) You must determine the four values in paragraphs (a)(4) through (7) of this section, using the calculations in paragraphs (b)(1) through (15) of this section.

(1) Determine the value of the bottom hole pressure, P_{BH} (psia), based on available information at the well site, or by calculating it using the reservoir pressure, P_R (psia), in the following equation:

Equation 2 to paragraph (b)(1)

$$P_{BH} \text{ (psia)} = \frac{1}{2} P_R$$

(2) Determine the value of the bottom hole temperature, T_{BH} (F), based on

available information at the well site, or by calculating it using the true vertical

depth of the well, L (ft), in the following equation:

Equation 3 paragraph (b)(2)

$$T_{BH} \text{ (F)} = (0.014 \times L) + 79.081$$

(3) Calculate the value of the applicable natural gas specific gravity that would result from a separator pressure of 100 psig, γ_{gs} , using the

following equation with: Separator at standard conditions (pressure, $p = 14.7$ (psia), temperature, $T = 60$ (F)); the oil API gravity at the well site, γ_o ; and the

gas specific gravity at the separator under standard conditions, $\gamma_{gp} = 0.75$:

Equation 4 to paragraph (b)(3)

$$\gamma_{gs} = \gamma_{gp} \cdot \left(1.0 + 5.912 \times 10^{-5} \cdot \gamma_o \cdot T \cdot \log \left(\frac{P}{114.7} \right) \right)$$

(4) Calculate the value of the applicable dissolved GOR, R_s (scf/STBO), using the following equation with: The bottom hole pressure, P_{BH} (psia), determined in (b)(1) of this

section; the bottom hole temperature, T_{BH} (F), determined in (b)(2) of this section; the gas gravity at separator pressure of 100 psig, γ_{gs} , calculated in (b)(3) of this section; the oil API gravity,

γ_o , at the well site; and the constants, C1, C2, and C3, found in Table 1 to this paragraph(b)(4):

Equation 5 to paragraph (b)(4)

$$R_s \left(\frac{\text{scf}}{\text{STBO}} \right) = C1 \cdot \gamma_{gs} \cdot P_{BH}^{C2} \cdot \exp \left[C3 \left(\frac{\gamma_o}{T_{BH} + 460} \right) \right]$$

TABLE 1 TO PARAGRAPH (b)(4)—COEFFICIENTS FOR THE CORRELATION FOR R_s

Constant	$\gamma_{API} \leq 30$	$\gamma_{API} > 30$
C1	0.0362	0.0178
C2	1.0937	1.1870
C3	25.7240	23.931

(5) Calculate the value of the oil formation volume factor, B_o (bbl/STBO), using the following equation with: The bottom hole temperature, T_{BH} (F), determined in paragraph (b)(2) of this section; the gas gravity at separator pressure of 100 psig, γ_{gs} , calculated in paragraph (b)(3) of this section; the dissolved GOR, R_s (scf/STBO),

calculated in paragraph (b)(4) of this section; the oil API gravity, γ_o , at the well site; and the constants, C1, C2, and C3, found in Table 2 to this paragraph (b)(5):

Equation 6 to paragraph (b)(5)

$$B_o \left(\frac{\text{bbl}}{\text{STBO}} \right) = 1.0 + C1 \cdot R_s + (T_{BH} - 60) \left(\frac{\gamma_o}{\gamma_{gs}} \right) \cdot (C2 + C3 \cdot R_s)$$

TABLE 2 TO PARAGRAPH (b)(5)—COEFFICIENTS FOR THE CORRELATION FOR B_o

Constant	$\gamma_{API} \leq 30$	$\gamma_{API} > 30$
C1	4.677×10^{-4}	4.670×10^{-4}
C2	1.751×10^{-5}	1.100×10^{-5}
C3	-1.811×10^{-8}	1.337×10^{-9}

using the following equation with the value of the oil API gravity, γ_o , at the well site:

Equation 7 to paragraph (b)(6)

$$\rho_{WH} \left(\frac{\text{lbm}}{\text{cu ft}} \right) = \frac{141.5}{\gamma_o + 131.5} \times 62.4$$

using the following equation with: the dissolved GOR, R_s (scf/STBO), calculated in paragraph (b)(4) of this section; the oil formation volume factor, B_o (bbl/STBO), calculated in paragraph (b)(5) of this section; the oil density at the wellhead,

$$\rho_{WH} \left(\frac{\text{lbm}}{\text{cu ft}} \right),$$

(6) Calculate the density of oil at the wellhead,

$$\rho_{WH} \left(\frac{\text{lbm}}{\text{cu ft}} \right),$$

(7) Calculate the density of oil at bottom hole conditions,

$$\rho_{BH} \left(\frac{\text{lbm}}{\text{cu ft}} \right),$$

calculated in paragraph (b)(6) of this section; and the dissolved gas gravity, $\gamma_{gd} = 0.77$:

Equation 8 to paragraph (b)(7)

$$\rho_{BH} \left(\frac{\text{lbm}}{\text{cu ft}} \right) = \frac{\rho_{WH} + 0.0136 \times R_s \times \gamma_{gd}}{B_o}$$

(8) Calculate the density of oil in the well,

$$\rho_o \left(\frac{\text{lbm}}{\text{cu ft}} \right),$$

using the following equation with the density of oil at the wellhead,

$$\rho_{WH} \left(\frac{\text{lbm}}{\text{cu ft}} \right),$$

calculated in paragraph (b)(6) of this section; and the density of oil at bottom hole conditions,

$$\rho_{BH} \left(\frac{\text{lbm}}{\text{cu ft}} \right),$$

calculated in paragraph (b)(7) of this section:

Equation 9 to paragraph (b)(8)

$$\rho_o \left(\frac{lbm}{cu\ ft} \right) = 0.5 \times (\rho_{WH} + \rho_{BH})$$

(9) Calculate the oil flow rate, q_o ($cu\ ft/sec.$) using the following equation with: the oil formation volume factor,

Bo (bbl/STBO), as calculated in paragraph (b)(5) of this section; and the

estimated oil production rate at the well head, Q_o (STBO/day):

Equation 10 to paragraph (b)(9)

$$q_o \left(\frac{cu\ ft}{sec} \right) = Q_o \left(\frac{STBO}{day} \right) \times Bo \left(\frac{bbl}{STBO} \right) \times 5.614 \left(\frac{cu\ ft}{bbl} \right) \times \frac{1}{24 \times 60 \times 60} \left(\frac{day}{sec} \right)$$

(10) Calculate the critical pressure, P_c (psia), and critical temperature, T_c (R), using the equations below with: Gas gravity at standard conditions (pressure, $P = 14.7$ (psia), temperature, $T = 60$ (F)), $\gamma = 0.75$; and where the mole fractions of nitrogen, carbon dioxide and hydrogen sulfide in the gas are $X_{N_2} =$

0.168225, $X_{CO_2} = 0.013163$, and $X_{H_2S} = 0.013680$, respectively:

$$P_c (psia) = 678 - 50 \cdot (\gamma_g - 0.5) - 206.7 \cdot X_{N_2} + 440 \cdot X_{CO_2} + 606.7 \cdot X_{H_2S}$$

$$T_c (R) = 326 + 315.7 \cdot (\gamma_g - 0.5) - 240 \cdot X_{N_2} - 88.3 \cdot X_{CO_2} + 133.3 \cdot X_{H_2S}$$

(11) Calculate reduced pressure, P_r , and reduced temperature, T_r , using the following equations with: the bottom hole pressure, P_{BH} , as determined in paragraph (b)(1) of this section; the bottom hole temperature, T_{BH} (F), as determined in paragraph (b)(2) of this section in the following equations:

Equation 11 to paragraph (b)(11)

$$P_r = \frac{P_{BH}}{P_c}$$

$$T_r = \frac{T_{BH} + 460}{T_c}$$

(12)(i) Calculate the gas compressibility factor, Z , using the following equation with the reduced

pressure, P_r , calculated in paragraph (b)(11) of this section:

Equation 12 to paragraph (b)(12)(i)

$$z = A + \frac{(1-A)}{e^B} + C \cdot p_r^D$$

(ii) The values for A, B, C, D in the above equation, are calculated using the

following equations with the reduced pressure, P_r , and reduced temperature,

T_r , calculated in paragraph (b)(11) of this section:

Equation 13 to paragraph (b)(12)(ii)

$$A = 1.39 \cdot (T_r - 0.92)^{0.5} - 0.36 \cdot T_r - 0.101$$

$$B = (0.62 - 0.23 \cdot T_r) \cdot P_r + \left(\frac{0.066}{(T_r - 0.86)} - 0.037 \right) \cdot P_r^2$$

$$+ \frac{0.32}{10^{9(T_r-1)}} \cdot P_r^6$$

$$C = (0.132 - 0.32 \cdot \log(T_r))$$

$$D = 10^{0.3106 - 0.49T_r + 0.1824T_r^2}$$

(13) Calculate the gas formation volume factor,

$$B_g \left(\frac{cuft}{scf} \right),$$

using the bottom hole pressure, P_{BH} (psia), as determined in paragraph (b)(1) of this section; and the bottom hole temperature, T_{BH} (F), as determined in paragraph (b)(2) of this section:

Equation 14 to paragraph (b)(13)

$$B_g \left(\frac{cuft}{scf} \right) = 0.0283 \cdot \frac{Z \cdot (T_{BH} + 460)}{P_{BH}} O$$

(14) Calculate the gas flow rate,

$$q_g \left(\frac{cuft}{sec} \right),$$

using the following equation with: the value of gas formation volume factor,

$$B_g \left(\frac{cuft}{scf} \right),$$

calculated in paragraph (b)(13) of this section; the estimated gas production rate, Q_g (scf/day); the estimated oil

production rate, Q_o (STBO/day); and the dissolved GOR, R_s (scf/STBO), as

calculated in paragraph (b)(4) of this section:

Equation 15 to paragraph (b)(14)

$$q_g \left(\frac{cf}{sec} \right) = (Q_g - R_s \cdot Q_o) \cdot B_g \cdot \frac{1}{24 \times 60 \times 60}$$

(15) Calculate the flow rate of water in the well, q_w (cu ft/sec), using the following equation with the water

production rate Q_w (bbl/day) at the well site:

Equation 16 to paragraph (b)(15)

$$q_w \left(\frac{cf}{sec} \right) = Q_w \left(\frac{bbl}{day} \right) \times 5.614 \left(\frac{cf}{bbl} \right) \times \frac{1}{24 \times 60 \times 60} \left(\frac{day}{sec} \right)$$

§§ 60.5433b – 60.5439b [Reserved]

TABLE 1 TO SUBPART OOOOb OF PART 60—ALTERNATIVE TECHNOLOGY PERIODIC SCREENING FREQUENCY AT WELL SITES, CENTRALIZED PRODUCTION FACILITIES, AND COMPRESSOR STATIONS SUBJECT TO AVO INSPECTIONS WITH QUARTERLY OGI OR EPA METHOD 21 MONITORING

Minimum screening frequency	Minimum detection threshold of screening technology* (kg/hr)
Quarterly	≤1
Bimonthly	≤2
Bimonthly + Annual OGI	≤10
Monthly	≤5

TABLE 1 TO SUBPART OOOOb OF PART 60—ALTERNATIVE TECHNOLOGY PERIODIC SCREENING FREQUENCY AT WELL SITES, CENTRALIZED PRODUCTION FACILITIES, AND COMPRESSOR STATIONS SUBJECT TO AVO INSPECTIONS WITH QUARTERLY OGI OR EPA METHOD 21 MONITORING—Continued

Minimum screening frequency	Minimum detection threshold of screening technology* (kg/hr)
Monthly + Annual OGI	≤15

* Based on a probability of detection of 90%.

TABLE 2 TO SUBPART OOOOb OF PART 60—ALTERNATIVE TECHNOLOGY PERIODIC SCREENING FREQUENCY AT WELL SITES AND CENTRALIZED PRODUCTION FACILITIES SUBJECT TO AVO INSPECTIONS AND/OR SEMIANNUAL OGI OR EPA METHOD 21 MONITORING

Minimum screening frequency	Minimum detection threshold of screening technology* (kg/hr)
Semiannual	≤1
Triannual	≤2
Triannual + Annual OGI	≤10
Quarterly	≤5
Quarterly + Annual OGI	≤15
Bimonthly	≤15

* Based on a probability of detection of 90%

TABLE 3 TO SUBPART OOOOb OF PART 60—REQUIRED MINIMUM INITIAL SO₂ EMISSION REDUCTION EFFICIENCY (Z_i)

H ₂ S content of acid gas (Y), %	Sulfur feed rate (X), LT/D			
	2.0 < X < 5.0	5.0 < X < 15.0	15.0 < X < 300.0	X > 300.0
Y > 50	79.0	88.51X ^{0.0101} Y ^{0.0125} or 99.9, whichever is smaller.		
20 < Y < 50	79.0	88.51X ^{0.0101} Y ^{0.0125} or 97.9, whichever is smaller		97.9
10 < Y < 20	79.0	88.51X ^{0.0101} Y ^{0.0125} or 93.5, whichever is smaller	93.5	93.5
Y < 10	79.0	79.0	79.0	79.0

TABLE 4 TO SUBPART OOOOb OF PART 60—REQUIRED MINIMUM SO₂ EMISSION REDUCTION EFFICIENCY (Z_c)

H ₂ S content of acid gas (Y), %	Sulfur feed rate (X), LT/D			
	2.0 < X < 5.0	5.0 < X < 15.0	15.0 < X < 300.0	X > 300.0
Y > 50	74.0	85.35X ^{0.0144} Y ^{0.0128} or 99.9, whichever is smaller.		
20 < Y < 50	74.0	85.35X ^{0.0144} Y ^{0.0128} or 97.5, whichever is smaller		97.5
10 < Y < 20	74.0	85.35X ^{0.0144} Y ^{0.0128} or 90.8, whichever is smaller	90.8	90.8
Y < 10	74.0	74.0	74.0	74.0

X = The sulfur feed rate from the sweetening unit (i.e., the H₂S in the acid gas), expressed as sulfur, Mg/D(LT/D), rounded to one decimal place.
 Y = The sulfur content of the acid gas from the sweetening unit, expressed as mole

percent H₂S (dry basis) rounded to one decimal place.
 Z = The minimum required sulfur dioxide (SO₂) emission reduction efficiency, expressed as percent carried to one decimal place. Z_i refers to the reduction

efficiency required at the initial performance test. Z_c refers to the reduction efficiency required on a continuous basis after compliance with Z_i has been demonstrated.

TABLE 5 TO SUBPART OOOOb OF PART 60—APPLICABILITY OF GENERAL PROVISIONS TO SUBPART OOOOb

General provisions citation	Subject of citation	Applies to subpart?	Explanation
§ 60.1	General applicability of the General Provisions.	Yes.	Additional terms defined in § 60.5430b.
§ 60.2	Definitions	Yes	
§ 60.3	Units and abbreviations	Yes.	
§ 60.4	Address	Yes.	

TABLE 5 TO SUBPART OOOOb OF PART 60—APPLICABILITY OF GENERAL PROVISIONS TO SUBPART OOOOb—Continued

General provisions citation	Subject of citation	Applies to subpart?	Explanation
§ 60.5	Determination of construction or modification.	Yes.	
§ 60.6	Review of plans	Yes.	
§ 60.7	Notification and record keeping	Yes	Except that § 60.7 only applies as specified in §§ 60.5417b(c) and 60.5420b(a).
§ 60.8	Performance tests	Yes	Except that the format and submittal of performance test reports is described in § 60.5420b(b) and (d). Performance testing is required for control devices used on storage vessels, centrifugal compressors, process controllers, and pumps complying with § 60.5393b(b)(1), except that performance testing is not required for a control device used solely on pump(s).
§ 60.9	Availability of information	Yes.	
§ 60.10	State authority	Yes.	
§ 60.11	Compliance with standards and maintenance requirements.	No	Requirements are specified in subpart OOOOb.
§ 60.12	Circumvention	Yes.	
§ 60.13	Monitoring requirements	Yes.	
§ 60.14	Modification	Yes	To the extent any provision in § 60.14 conflicts with specific provisions in subpart OOOOb, it is superseded by subpart OOOOb provisions.
§ 60.15	Reconstruction	Yes	Except that § 60.15(d) does not apply to wells (i.e., well completions, well liquids unloading, associated gas wells), process controllers, pumps, centrifugal compressors, reciprocating compressors, storage vessels, or fugitive emissions components affected facilities.
§ 60.16	Priority list	Yes.	
§ 60.17	Incorporations by reference	Yes.	
§ 60.18	General control device and work practice requirements.	Yes.	
§ 60.19	General notification and reporting requirement.	Yes.	

■ 33. Add subpart OOOOc to part 60 to read as follows:

Subpart OOOOc—Emissions Guidelines for Greenhouse Gas Emissions From Existing Crude Oil and Natural Gas Facilities

Introduction

- 60.5360c What is the purpose of this subpart?
- 60.5361c Which pollutants are regulated by this subpart?
- 60.5362c Am I affected by this subpart?
- 60.5363c What must I include in my state or Tribal plan?
- 60.5364c How do I apply to use my state standards as part of my state or Tribal plan submission?
- 60.5365c How do I apply for a less stringent standard taking into consideration the remaining useful life of a designated facility and other factors?
- 60.5366c [Reserved]
- 60.5367c Is there an approval process for my state or Tribal plan?
- 60.5368c What if my state or Tribal plan is not approvable?
- 60.5369c Is there an approval process for a negative declaration letter?
- 60.5370c What compliance schedule must I include in my state or Tribal plan?
- 60.5371c What requirements apply to revisions to my state or Tribal plan?
- 60.5372c In lieu of a state or Tribal plan submittal, are there other acceptable option(s) for a state to meet its Clean Air Act section 111(d) obligations?

- 60.5373c What authorities will not be delegated to state, local, or Tribal agencies?
- 60.5374c Does this subpart directly affect designated facility owners and operators in my state?

Applicability of State or Tribal Plans

- 60.5375c What designated facilities must I address in my state or Tribal plan?

Use of Model Rule

- 60.5376c What is the “model rule” in this subpart?
- 60.5377c How does the model rule relate to the required elements of my state or Tribal plan?
- 60.5378c What are the principal components of the model rule?

Model Rule—Increments of Progress

- 60.5379c What are my requirements for meeting increments of progress and achieving final compliance?
- 60.5380c What if I do not meet the final control plan increment of progress compliance date?
- 60.5381c How do I comply with the increment of progress for submittal of a final compliance control plan?

Model Rule—Applicability

- 60.5385c What is the purpose of this subpart?
- 60.5386c Am I subject to this subpart?
- 60.5387c When must I comply with this subpart?

Model Rule—Emission and Work Practice Standards

- 60.5388c What standards apply to super-emitter events?
- 60.5390c What GHG standards apply to gas well liquids unloading operations at well designated facilities?
- 60.5391c What GHG standards apply to associated gas wells at well designated facilities?
- 60.5392c What GHG standards apply to centrifugal compressor designated facilities?
- 60.5393c What GHG standards apply to reciprocating compressor designated facilities?
- 60.5394c What GHG standards apply to process controller designated facilities?
- 60.5395c What GHG standards apply to pump designated facilities?
- 60.5396c What GHG standards apply to storage vessel designated facilities?
- 60.5397c What GHG standards apply to fugitive emissions components designated facilities?
- 60.5398c What alternative GHG standards apply to fugitive emissions components designated facilities and what monitoring and inspection requirements apply to covers and closed vent systems when using an alternative technology?
- 60.5400c What GHG standards apply to process unit equipment designated facilities?
- 60.5401c What are the alternative GHG standards for process unit equipment designated facilities?

60.5402c What are the exceptions to the GHG standards for process unit equipment designated facilities?

Model Rule—Test Methods and Performance Testing

60.5405c What test methods and procedures must I use for my centrifugal compressor and reciprocating compressor designated facilities?

60.5406c What test methods and procedures must I use for my process unit equipment designated facilities?

Model Rule—Initial Compliance Requirements

60.5410c How do I demonstrate initial compliance with the standards for each of my designated facilities?

60.5411c What additional requirements must I meet to determine initial compliance for my covers and closed vent systems?

60.5412c What additional requirements must I meet for determining initial compliance of my control devices?

60.5413c What are the performance testing procedures for control devices?

Model Rule—Continuous Compliance Requirements

60.5415c How do I demonstrate continuous compliance with the standards for each of my designated facilities?

60.5416c What are the initial and continuous cover and closed vent system inspection and monitoring requirements?

60.5417c What are the continuous monitoring requirements for my control devices?

Model Rule—Recordkeeping and Reporting

60.5420c What are my notification, reporting, and recordkeeping requirements?

60.5421c What are my additional recordkeeping requirements for process unit equipment designated facilities?

60.5422c What are my additional reporting requirements for process unit equipment designated facilities?

60.5424c What are my additional recordkeeping and reporting requirements if I comply with the alternative GHG standards for fugitive emissions components designated facilities and covers and closed vent systems?

60.5425c What parts of the General Provisions apply to me?

Model Rule—Definitions

60.5430c What definitions apply to this subpart?

60.5431c–60.5439c [Reserved]
Table 1 to Subpart OOOOc of Part 60—Designated Facility Presumptive Standards and Regulated Entity Compliance Dates

Table 2 to Subpart OOOOc of Part 60—Alternative Technology Periodic Screening Frequency at Well Sites, Centralized Production Facilities, and Compressor Stations Subject to AVO Inspections With Quarterly OGI or EPA Method 21 Monitoring

Table 3 to Subpart OOOOc of Part 60—Alternative Technology Periodic Screening Frequency at Well Sites and Centralized Production Facilities Subject to AVO Inspections and/or Semiannual OGI or EPA Method 21 Monitoring

Table 4 to Subpart OOOOc of Part 60—Applicability of General Provisions to Subpart OOOOc

Introduction

§ 60.5360c What is the purpose of this subpart?

This subpart establishes emission guidelines and compliance schedules for the control of greenhouse gas (GHG) emissions from designated facilities in the crude oil and natural gas source category as defined in the Model Rule at § 60.5430c, in accordance with section 111(d) of the Clean Air Act and subpart Ba of this part. The designated facilities, standards section reference and compliance dates are listed in table 1 to this subpart. To the extent any requirement of this subpart is inconsistent with the requirements of subpart A or Ba of this part, the requirements of this subpart will apply.

§ 60.5361c Which pollutants are regulated by this subpart?

(a) *Scope.* The pollutants regulated by this subpart are greenhouse gases (GHG). The greenhouse gas standards in this subpart are in the form of a limitation on emissions of methane from designated facilities in the crude oil and natural gas source category that commenced construction, modification, or reconstruction on or before December 6, 2022.

(b) *PSD and title V Thresholds for Greenhouse Gases.* (1) For the purposes of 40 CFR 51.166(b)(49)(ii), with respect to GHG emissions from facilities, the “pollutant that is subject to any standard promulgated under section 111 of the Act” shall be considered to be the pollutant that otherwise is subject to regulation under the Act as defined in 40 CFR 51.166(b)(48) and in any State Implementation Plan (SIP) approved by the EPA that is interpreted to incorporate, or specifically incorporates, 40 CFR 51.166(b)(48).

(2) For the purposes of 40 CFR 52.21(b)(50)(ii), with respect to GHG emissions from facilities regulated in the plan, the “pollutant that is subject to any standard promulgated under section 111 of the Act” shall be considered to be the pollutant that otherwise is subject to regulation under the Act as defined in 40 CFR 52.21(b)(49).

(3) For the purposes of 40 CFR 70.2, with respect to GHG emissions from facilities regulated in the plan, the “pollutant that is subject to any

standard promulgated under section 111 of the Act” shall be considered to be the pollutant that otherwise is “subject to regulation” as defined in 40 CFR 70.2.

(4) For the purposes of 40 CFR 71.2, with respect to GHG emissions from facilities regulated in the plan, the “pollutant that is subject to any standard promulgated under section 111 of the Act” shall be considered to be the pollutant that otherwise is “subject to regulation” as defined in 40 CFR 71.2 40 CFR.

§ 60.5362c Am I affected by this subpart?

(a) If you are the Administrator of an air pollution control agency in a state or United States protectorate with one or more designated facilities that commenced construction, modification, or reconstruction on or before December 6, 2022, you must submit a state or Tribal plan to the U.S. Environmental Protection Agency (EPA) that implements the emission guidelines contained in this subpart. The submission of such plan shall be made in electronic format according to subpart Ba of this part.

(b) If you are the Administrator of an air pollution control agency in a state or United States protectorate with no designated facilities for which construction commenced on or before December 6, 2022, you must submit a negative declaration letter in place of the state or Tribal plan. The submission of such negative declaration letter shall be made in electronic format according to subpart Ba of this part.

(c) You must submit the state or Tribal plan or negative declaration letter to EPA by the date March 9, 2026.

§ 60.5363c What must I include in my state or Tribal plan?

(a) You must include the ten items described in paragraphs (a)(1) through (10) of this section in your state or Tribal plan.

(1) Inventory of designated facilities. For purposes of this subpart, § 60.25a(a) does not apply.

(2) Inventory of emissions from designated facilities in your state. For purposes of this subpart, § 60.25a(a) does not apply.

(3) Compliance schedules for each designated facility or logical grouping of designated facilities.

(4) Standards of performance for designated facilities that are at least as stringent as the emission guidelines contained in this subpart, unless otherwise provided for under

§ 60.5365c. Standards for performance for designated facilities must apply at all times, including periods of startup, shutdown, and malfunction.

(5) Performance testing, monitoring, recordkeeping, and reporting requirements.

(6) Documentation of meaningful engagement on such plan or plan revisions as specified in § 60.23a(i).

(7) Certification that the required hearing on the state or Tribal plan was held, a list of witnesses and their organizational affiliations, if any, appearing at the hearing, and a brief written summary of each presentation or written submission as specified in § 60.23a(c) through (e).

(8) Provision for state progress reports to EPA.

(9) Identification of enforceable state mechanisms that you selected for implementing the emission guidelines of this subpart.

(10) Demonstration of your state's legal authority to carry out the Clean Air Act section 111(d) state or Tribal plan.

(b) Unless superseded by this subpart, you must follow the requirements of subpart Ba of this part (Adoption and Submittal of State Plans for Designated Facilities) in your state or Tribal plan.

§ 60.5364c How do I apply to use my state standards as part of my state or Tribal plan submission?

In order for you to apply to use your state standards as part of your state or Tribal plan submission your state requirements for designated facilities must meet the standards of performance criteria specified in paragraph (a) of this section and you must provide the supporting documentation that you met those criteria as specified in paragraph (b) of this section.

(a) You must demonstrate that the state standards of performance established for a designated facility in your state or Tribal plan meet the equivalency criteria specified in paragraphs (a)(1) through (6) of this section when compared to the designated facility presumptive standards specified in EG 0000c.

(1) Designated facility,
 (2) Designated pollutant,
 (3) Standard type/format of standard,
 (4) Emission reductions (considering applicability thresholds and exemptions) unless relying on § 60.5365c,

(5) Compliance determination method, and

(6) Ongoing compliance assurance requirements (e.g., monitoring, recordkeeping and reporting requirements).

(b) You must provide the supporting documentation that you met the equivalency criteria specified in paragraph (a) of this section as specified in paragraphs (b)(1) through (3) of this section.

(1) Your state or Tribal plan should identify the designated facility requirements of your state program that you are submitting for approval to become federally enforceable requirements under the plan.

(2) You must include a detailed explanation and analysis of how the relied upon state standards are at least as stringent as the requirements of the final EG based on each of the criteria specified in paragraph (a) of this section, or comply with § 60.5365c for paragraph (a)(4) of this section.

(3) You must include a copy of the actual state law/regulation or document submitted for approval and incorporation into the state or Tribal plan.

§ 60.5365c How do I apply for a less stringent standard taking into consideration the remaining useful life of a designated facility and other factors?

You may apply a standard of performance to a designated facility that is less stringent than otherwise required by the emission guidelines, provided you meet the requirements specified in § 60.24a.

§ 60.5366c [Reserved.]

§ 60.5367c Is there an approval process for my state or Tribal plan?

Yes. The EPA will review your state or Tribal plan according to § 60.27a.

(a) The EPA will determine the completeness of your plan submission according to § 60.27a(g).

(b) The EPA will act on your plan submission according to § 60.27a.

§ 60.5368c What if my state or Tribal plan is not approvable?

If you do not submit a state or Tribal plan (or a negative declaration letter) by March 9, 2026, or if EPA disapproves your state plan, EPA will develop a Federal plan according to § 60.27a(c) through (f) to implement the emission guidelines contained in this subpart.

§ 60.5369c Is there an approval process for a negative declaration letter?

No. The EPA has no formal review process for negative declaration letters. Once your negative declaration letter has been received, the EPA will place a copy in the public docket and publish a notice in the **Federal Register**. If, at a later date, a designated facility for which construction commenced on or before December 6, 2022, is found in your state, that designated facility must be subject to a state, Tribal, or Federal plan in accordance with the requirements of this subpart and subpart Ba.

§ 60.5370c What compliance schedule must I include in my state or Tribal plan?

(a) For designated facilities that commenced construction, modification or reconstruction on or before December 6, 2022, your state or Tribal plan must include compliance schedules that require designated facilities to achieve final compliance as expeditiously as practicable after approval of the state or Tribal plan but not later than the dates specified in § 60.5360c of this subpart, as applicable to each designated facility.

(b) The plan must include legally enforceable increments of progress to achieve compliance for each designated facility or category of facilities, as specified in §§ 60.5380c through 60.5382c.

§ 60.5371c What requirements apply to revisions to my state or Tribal plan?

(a) Any significant revision to a state or Tribal plan shall be adopted and submitted as specified in § 60.28a.

(b) A revision of a plan, or any portion thereof, shall not be considered part of an applicable plan until approved by the Administrator in accordance with this subpart and subpart Ba of this part.

§ 60.5372c In lieu of a state or Tribal plan submittal, are there other acceptable option(s) for a state to meet its Clean Air Act section 111(d) obligations?

Yes, a state may meet its Clean Air Act section 111(d) obligations by submitting an acceptable written request for delegation of an applicable Federal plan that meets the requirements of this section. This is the only other option for a state to meet its section 111(d) obligations.

(a) An acceptable Federal plan delegation request must include the following:

(1) A demonstration of adequate resources and legal authority to administer and enforce the Federal plan.

(2) The items under § 60.5363c(a)(1), (a)(2), and (a)(8) of this subpart.

(3) Certification that the hearing on the state delegation request, similar to the hearing for a state or Tribal plan submittal, was held, a list of witnesses and their organizational affiliations, if any, appearing at the hearing, and a brief written summary of each presentation or written submission.

(4) A commitment to enter into a Memorandum of Agreement with the Regional Administrator that sets forth the terms, conditions, and effective date of the delegation and that serves as the mechanism for the transfer of authority. Additional guidance and information is given in EPA's Delegation Manual, Item 7-139, Implementation and Enforcement of 111(d)(2) and 111(d)/(2)/129 (b)(3) Federal plans.

(b) A state with an already approved oil and natural gas designated facility Clean Air Act section 111(d) state or Tribal plan is not precluded from receiving the EPA's approval of a delegation request for any revised Federal plan, provided the requirements of paragraph (a) of this section are met, and at the time of the delegation request, the state also requests withdrawal of the EPA's previous state or Tribal plan approval.

(c) A state's Clean Air Act section 111(d) obligations are separate from its obligations under title V of the Clean Air Act.

§ 60.5373c What authorities will not be delegated to state, local, or Tribal agencies?

The authorities that will not be delegated to state, local, or Tribal agencies are specified in paragraphs (a) through (h) of this section.

(a) Approval of alternatives to the emission limits and standards in tables 1, 2, and 3 to this subpart and operating limits established under § 60.5412c, § 60.5415c, or § 60.5417c.

(b) Approval of major alternatives to test methods.

(c) Approval of major alternatives to monitoring.

(d) Approval of major alternatives to recordkeeping and reporting.

(e) Approval of an alternative to any electronic reporting required by this subpart.

(f) [Reserved.]

(g) [Reserved.]

(h) Performance test and data reduction waivers under § 60.8(b).

§ 60.5374c Does this subpart directly affect designated facility owners and operators in my state?

(a) No. This subpart does not directly affect designated facility owners and operators in your state. However, designated facility owners and operators must comply with the state or Tribal plan you develop to implement the emission guidelines contained in this subpart. States may choose to incorporate the model rule text directly in their state or Tribal plan.

(b) If you do not submit a plan to implement and enforce the guidelines contained in this subpart by the date 24 months after promulgation of this subpart, or if EPA disapproves your plan, the EPA will implement and enforce a Federal plan, as provided in § 60.5367c of this subpart, to ensure that each designated facility within your state that commenced construction, modification or reconstruction on or before December 6, 2022, reaches compliance with all the provisions of

this subpart by the dates specified in § 60.5360c of this subpart.

Applicability of State or Tribal Plans

§ 60.5375c What designated facilities must I address in my state or Tribal plan?

(a) Your state or Tribal plan must address designated facilities that meet all three criteria described in paragraphs (a)(1) through (3) of this section.

(1) Designated facilities in your state that commenced construction, modification, or reconstruction on or before December 6, 2022.

(2) Designated facilities that are listed in table 1 to this subpart.

(3) Designated facilities not exempt under § 60.14c.

(b) If the owner or operator of a designated facility makes changes that meet the definition of modification after December 6, 2022, the designated facility becomes subject to subpart OOOOb of this part, and the state or Tribal plan no longer applies to that facility.

(c) If the owner or operator of a designated facility makes physical or operational changes to a designated facility for which construction commenced on or before September 9, 2024, primarily to comply with your state or Tribal plan, subpart OOOOb of this part, does not apply to that designated facility. Such changes do not qualify as modifications under subpart OOOOb of this part.

Use of Model Rule

§ 60.5376c What is the "model rule" in this subpart?

(a) The model rule is the portion of these emission guidelines (§§ 60.5385c through 60.5430c of this subpart) that includes the presumptive standards for designated facilities as well as associated measures to assure compliance including monitoring, recordkeeping, and reporting. The model rule is organized in regulation format. You must develop a state or Tribal plan that is at least as protective as the model rule, or comply with § 60.5365c. You may use the model rule language as part of your state or Tribal plan. Alternative language may be used in your state or Tribal plan if you demonstrate that the alternative language is at least as protective as the model rule contained in this subpart, or comply with § 60.5365c.

(b) In the model rule of §§ 60.5385c through 60.5430c, "Administrator" has the meaning specified in § 60.2.

§ 60.5377c How does the model rule relate to the required elements of my state or Tribal plan?

You may use the model rule to satisfy the state or Tribal plan requirements specified in § 60.5363c(a)(3) through (a)(5).

§ 60.5378c What are the principal components of the model rule?

The model rule contains the nine major components listed in paragraphs (a) through (i) of this section.

(a) Increments of progress toward compliance.

(b) Operator training and qualification.

(c) Emission limits, emission standards, and operating limits.

(d) Initial compliance requirements.

(e) Continuous compliance requirements.

(f) Performance testing, monitoring, and calibration requirements.

(g) Recordkeeping and reporting.

(h) Definitions.

(i) Tables.

Model Rule—Increments of Progress

§ 60.5379c What are my requirements for meeting increments of progress and achieving final compliance?

You must meet one increment of progress as specified in paragraph (a) of this section and you must submit the Notification of Compliance report as specified in paragraph (b) of this section.

(a) Submit a final compliance control plan on or before 28 months after the state plan submittal deadline specified in § 60.5362c(c).

(b) Submit a Notification of Compliance report on or before 60 days after the state plan compliance date as specified in § 60.5420c.

§ 60.5380c What if I do not meet the final control plan increment of progress compliance date?

If you fail to meet the final compliance control plan increment of progress report compliance date, you must submit a notification to the Administrator postmarked within 10 business days after the required submittal date for that increment of progress. You must inform the Administrator that you did not meet the increment, and you must continue to submit reports each subsequent calendar month until the increment of progress is met.

§ 60.5381c How do I comply with the increment of progress for submittal of a final compliance control plan?

For your final compliance control plan increment of progress report, you must satisfy the requirements specified

in paragraphs (a) through (c) of this section.

(a) Your final control plan must include the information specified paragraphs (a)(1) and (2) of this section.

(1) A description of the designated facilities covered under your plan.

(2) The emissions control methods that you plan to implement for each designated facility covered under your plan.

(b) A company is allowed to submit one plan that covers all of the company's designated facilities in a state in lieu of submitting a plan for each designated facility.

(c) Maintain an onsite copy of the final control plan.

Model Rule—Applicability

§ 60.5385c What is the purpose of this subpart?

(a) *Scope.* This subpart establishes emission standards and compliance schedules for the control of the pollutant greenhouse gases (GHG). The greenhouse gas standard in this subpart is in the form of a limitation on emissions of methane from designated facilities in the crude oil and natural gas source category that commence construction, modification, or reconstruction on or before December 6, 2022.

(b) *Prevention of Significant Deterioration (PSD) and title V thresholds for Greenhouse Gases.* (1) For the purposes of 40 CFR 51.166(b)(49)(ii), with respect to GHG emissions from designated facilities, the “pollutant that is subject to the standard promulgated under section 111 of the Act” shall be considered the pollutant that otherwise is subject to regulation under the Act as defined in 40 CFR 51.166(b)(48) and in any State Implementation Plan (SIP) approved by the EPA that is interpreted to incorporate, or specifically incorporates, 40 CFR 51.166(b)(48).

(2) For the purposes of 40 CFR 52.21(b)(50)(ii), with respect to GHG emissions from designated facilities, the “pollutant that is subject to the standard promulgated under section 111 of the Act” shall be considered the pollutant that otherwise is subject to regulation under the Clean Air Act as defined in 40 CFR 52.21(b)(49).

(3) For the purposes of 40 CFR 70.2, with respect to GHG emissions from designated facilities, the “pollutant that is subject to any standard promulgated under section 111 of the Act” shall be considered the pollutant that otherwise is “subject to regulation” as defined in 40 CFR 70.2.

(4) For the purposes of 40 CFR 71.2, with respect to GHG emissions from

designated facilities, the “pollutant that is subject to any standard promulgated under section 111 of the Act” shall be considered the pollutant that otherwise is “subject to regulation” as defined in 40 CFR 71.2.

(c) *Exemption.* You are exempt from the obligation to obtain a permit under 40 CFR part 70 or 40 CFR part 71, provided you are not otherwise required by law to obtain a permit under 40 CFR 70.3(a) or 40 CFR 71.3(a). Notwithstanding the previous sentence, you must continue to comply with the provisions of this subpart.

§ 60.5386c Am I subject to this subpart?

You are subject to the applicable provisions of this subpart if you are the owner or operator of one or more of the onshore designated facilities listed in paragraphs (a) through (h) of this section, that is located within the Crude Oil and Natural Gas source category, as defined in § 60.5430c, for which you commence construction, modification, or reconstruction on or before December 6, 2022. Facilities located inside and including the Local Distribution Company (LDC) custody transfer station are not subject to this subpart.

(a) Each well designated facility, which is a single well drilled for the purpose of producing oil or natural gas.

(b) Each centrifugal compressor designated facility, which is a single centrifugal compressor. A centrifugal compressor located at a well site is not a designated facility under this subpart. A centrifugal compressor located at a centralized production facility is a designated facility under this subpart.

(c) Each reciprocating compressor designated facility, which is a single reciprocating compressor. A reciprocating compressor located at a well site is not a designated facility under this subpart. A reciprocating compressor located at a centralized production facility is a designated facility under this subpart.

(d) Each process controller designated facility, which is the collection of natural gas-driven process controllers at a well site, centralized production facility, onshore natural gas processing plant, or a compressor station. Natural gas-driven process controllers that function as emergency shutdown devices and process controllers that are not driven by natural gas are exempt from the designated facility.

(e)(1) Each storage vessel designated facility, which is a tank battery that has the potential for methane emissions equal to or greater than 20 tpy as specified in paragraph (e)(2) of this section. A tank battery with the potential for methane emissions below

20 tpy is not a storage vessel designated facility provided the owner or operator keeps records of the potential for emissions calculation for the life of the storage vessel or until such time the tank battery becomes a storage vessel designated facility because the potential for methane emissions meets or exceeds 20 tpy.

(2) The potential for methane emissions must be calculated as the cumulative emissions from all storage vessels within the tank battery as specified by the applicable requirements in paragraphs (e)(2)(i) through (iii) of this section. The determination may take into account requirements under a legally and practicably enforceable limit in an operating permit or other requirement established under a Federal, state, local, or Tribal authority.

(i) For purposes of determining the applicability of a storage vessel tank battery as a designated facility, a legally and practicably enforceable limit must include the elements provided in paragraphs (e)(2)(i)(A) through (F) of this section.

(A) A quantitative production limit and quantitative operational limit(s) for the equipment, or quantitative operational limits for the equipment;

(B) An averaging time period for the production limit in (e)(2)(i)(A), if a production-based limit is used, that is equal to or less than 30 days;

(C) Established parametric limits for the production and/or operational limit(s) in (e)(1)(i)(A), and where a control device is used to achieve an operational limit, an initial compliance demonstration (*i.e.*, performance test) for the control device that establishes the parametric limits;

(D) Ongoing monitoring of the parametric limits in (e)(2)(i)(C) that demonstrates continuous compliance with the production and/or operational limit(s) in (e)(2)(i)(A);

(E) Recordkeeping by the owner or operator that demonstrates continuous compliance with the limit(s) in (e)(2)(i)(A) through (D); and

(F) Periodic reporting that demonstrates continuous compliance.

(ii) For each tank battery located at a well site or centralized production facility, you must determine the potential for methane emissions within 60 days after the effective date of the approved state or Tribal plan, except as provided in paragraph (e)(4)(iv) of this section. The potential for methane emissions must be calculated using a generally accepted model or calculation methodology that accounts for flashing, working, and breathing losses, based on the maximum average daily throughput

to the tank battery determined for a 30-day period of production.

(iii) For each tank battery not located at a well site or centralized production facility, including each tank battery located at a compressor station or onshore natural gas processing plant, you must determine the potential for methane emissions within 60 days after the effective date of the approved state or Tribal plan, using either method described in paragraph (e)(2)(iii)(A) or (B) of this section.

(A) Determine the potential for methane emissions using a generally accepted model or calculation methodology that accounts for flashing, working, and breathing losses, and based on the throughput to the tank battery established in a legally and practicably enforceable limit in an operating permit or other requirement established under a Federal, state, local, or Tribal authority; or

(B) Determine the potential for methane emissions using a generally accepted model or calculation methodology that accounts for flashing, working and breathing losses, based on projected maximum average daily throughput. Maximum average daily throughput is determined using a generally accepted engineering model (e.g., volumetric condensate rates from the tank battery based on the maximum gas throughput capacity of each producing facility) to project the maximum average daily throughput for the tank battery.

(3) A storage vessel designated facility that subsequently has its potential for methane emissions decrease to less than 20 tpy shall remain a designated facility under this subpart.

(4) For storage vessels not subject to a legally and practicably enforceable limit in an operating permit or other requirement established under Federal, state, local, or Tribal authority, any vapor from the storage vessel that is recovered and routed to a process through a vapor recovery unit designed and operated as specified in this section is not required to be included in the determination of potential for methane emissions for purposes of determining designated facility status, provided you comply with the requirements of paragraphs (e)(4)(i) through (iv) of this section.

(i) You meet the cover requirements specified in § 60.5411c(b).

(ii) You meet the closed vent system requirements specified in § 60.5411c(a)(2) through (4) and (c).

(iii) You must maintain records that document compliance with paragraphs (e)(4)(i) and (ii) of this section.

(iv) In the event of removal of apparatus that recovers and routes vapor to a process, or operation that is inconsistent with the conditions specified in paragraphs (e)(4)(i) and (ii) of this section, you must determine the storage vessel's potential for methane emissions according to this section within 30 days of such removal or operation.

(5) The requirements of this paragraph (e)(5) apply to each storage vessel designated facility immediately upon return to service. A storage vessel designated facility or portion of a storage vessel designated facility that is reconnected to the original source of liquids remains a storage vessel designated facility subject to the same requirements that applied before being removed from service. Any storage vessel that is used to replace a storage vessel designated facility or portion of a storage vessel designated facility, or used to expand a storage vessel designated facility assumes the designated facility status of the storage vessel designated facility being replaced or expanded.

(6) A storage vessel with a capacity greater than 100,000 gallons used to recycle water that has been passed through two stage separation is not a storage vessel designated facility.

(f) Each process unit equipment designated facility, which is the group of all equipment within a process unit at an onshore natural gas processing plant is a designated facility. Equipment associated with a compressor station, dehydration unit, sweetening unit, underground storage vessel, field gas gathering system, or liquefied natural gas unit is covered by §§ 60.5400c, 60.5401c, 60.5402c, 60.5421c, and 60.5422c if it is located at an onshore natural gas processing plant. Equipment not located at the onshore natural gas processing plant site is exempt from the provisions of §§ 60.5400c, 60.5401c, 60.5402c, 60.5421c, and 60.5422c.

(g) Each pump designated facility, which is the collection of natural gas-driven diaphragm and piston pumps at a well site, centralized production facility, onshore natural gas processing plant, or a compressor station. Pumps that are not driven by natural gas and that are not in operation 90 days or more per calendar year are not included in the pump designated facility.

(h) Each fugitive emissions components designated facility, which is the collection of fugitive emissions components at a well site, centralized production facility, or a compressor station.

§ 60.5387c When must I comply with this subpart?

Table 1 of this subpart specifies the final compliance date.

Model Rule—Emission and Work Practice Standards

§ 60.5388c What standards apply to super-emitter events?

This section applies to super-emitter events. For purposes of this section, a super-emitter event is defined as any emissions event that is located at an oil and natural gas facility (e.g., individual well site, centralized production facility, natural gas processing plant, or compressor station) and that is detected using remote detection methods and has a quantified emission rate of 100 kg/hr of methane or greater. Upon receiving a notification of a super emitter event issued by the EPA under § 60.5371b(c) in subpart OOOOb of this part, owners or operators must take the actions listed in paragraphs (a) and (b) of this section. Within 5 calendar days of receiving a notification from the EPA of a super-emitter event, the owner or operator of an oil and natural gas facility (e.g., a well site, centralized production facility, natural gas processing plant, or compressor station) must initiate a super-emitter event investigation.

(a) *Identification of super-emitter events.* (1) If you do not own or operate an oil and natural gas facility within 50 meters from the latitude and longitude provided in the notification subject to the regulation under this subpart, report this result to the EPA under paragraph (e) of this section. Your super-emitter event investigation is deemed complete under this subpart.

(2) If you own or operate an oil and natural gas facility within 50 meters from the latitude and longitude provided in the notification, and there is a designated facility or associated equipment subject to this subpart onsite, you must investigate to determine the source of the super-emitter event in accordance with this paragraph (a) and report the results in accordance with paragraph (b) of this section.

(3) The investigation required by paragraph (a)(2) of this section may include but is not limited to the actions specified below in paragraphs (a)(2)(i) through (v) of this section.

(i) Review any maintenance activities (e.g., liquids unloading) or process activities from the designated facilities subject to regulation under this subpart, starting from the date of detection of the super-emitter event as identified in the notification, until the date of investigation, to determine if the activities indicate any potential

source(s) of the super-emitter event emissions.

(ii) Review all monitoring data from control devices (e.g., flares) from the designated facilities subject to regulation under this subpart from the initial date of detection of the super-emitter event as identified in the notification, until the date of receiving the notification from the EPA to identify malfunctions of control devices or periods when the control devices were not in compliance with applicable requirements and that indicate a potential source of the super-emitter event emissions.

(iii) If you conducted a fugitive emissions survey or periodic screening event in accordance with § 60.5397c or § 60.5398c(b) between the initial date of detection of the super-emitter event as identified in the notification and the date the notification from the EPA was received, review the results of the survey to identify any potential source(s) of the super-emitter event emissions.

(iv) If you use conduct continuous monitoring with advanced methane detection technology in accordance with § 60.5398c(c), review the monitoring data collected on or after the initial date of detection of the super-emitter event as identified in the notification, until the date of receiving the notification from the EPA.

(v) Screen the entire well site, centralized production facility, or compressor station with OGI, Method 21 of appendix A-7 to this part, or an alternative test method(s) approved per § 60.5398c(d), to determine if a super-emitter event is present.

(4) If the source of the super-emitter event was found to be from fugitive emission components at a well site, centralized production facility, or compressor station subject to this subpart, you must comply with the repair requirements under § 60.5397c and the associated recordkeeping and reporting requirements under § 60.5420c(b)(8) and § 60.5420c(c)(13).

(b) *Super-emitter event report.* You must submit the results of the super-emitter event investigation conducted under paragraph (a) of this section to the EPA in accordance with paragraph (b)(1) of this section. If the super-emitter event (i.e., emission at 100 kg/hr of methane or more) is ongoing at the time of the initial report, submit the additional information in accordance with paragraph (b)(2) of this section. You must attest to the information included in the report as specified in paragraph (b)(3) of this section.

(1) Within 15 days of receiving a notification from the EPA under

§ 60.5371b(c), you must submit a report of the super-emitter event investigation conducted under paragraph (a) of this section through the Super-Emitter Program Portal, at www.epa.gov/super-emitter. You must include the applicable information in paragraphs (b)(1)(i) through (viii) of this section in the report. If you have identified a demonstrable error in the notification, the report may include a statement of the demonstrable error.

(i) Notification Report ID of the super-emitter event notification.

(ii) Identification of whether you are the owner or operator of an oil and natural gas facility that is located within 50 meters from the latitude and longitude provided in the EPA notification. If you do not own or operate an oil and natural gas facility within 50 meters from the latitude and longitude provided in the EPA notification, you are not required to report the information in paragraphs (b)(1)(iii) through (viii) of this section.

(iii) General identification information for the facility, including, facility name, the physical address, applicable ID Number (e.g., EPA ID Number, API Well ID Number), the owner or operator or responsible official (where applicable) and their email address.

(iv) Identification of whether there is a designated facility or associated equipment subject to regulation under this subpart at this oil and natural gas facility.

(v) Indication of whether you were able to identify the source of the super-emitter event. If you indicate you were unable to identify the source of the super-emitter event, you must certify that all applicable investigations specified in paragraphs (a)(3)(i) through (v) of this section have been conducted for all designated facilities and associated equipment subject to regulation under this subpart that are at this oil and natural gas facility, and you have determined that the designated facilities and associated equipment are not the source of the super-emitter event. If you indicate that you were not able to identify the source of the super-emitter event, you are not required to report the information in paragraphs (b)(1)(vi) through (viii) of this section.

(vi) The source(s) of the super-emitter event.

(vii) Identification of whether the source of the super-emitter event is a designated facility or associated equipment subject to regulation under this subpart. If the source of the super-emitter event is a designated facility or associated equipment subject to regulation under this subpart,

identify the applicable regulation(s) under this subpart.

(viii) Indication of whether the super-emitter event is ongoing at the time of the initial report submittal (i.e., emission at 100 kg/hr of methane or more).

(A) If the super-emitter event is not ongoing at the time of the initial report submittal, provide the actual (or if not known, estimated) date and time the super-emitter event ended.

(B) If the super-emitter event is ongoing at the time of the initial report submittal, provide a short narrative of your plan to end the super-emitter event, including the targeted end date for the efforts to be completed and the super-emitter event ended.

(2) If the super-emitter event is ongoing at the time of the initial report submittal, within 5 business days of the date the super-emitter event ends you must update your initial report through the Super-Emitter Program Portal to provide the end date and time of the super-emitter event.

(3) You must sign the following attestation when submitting data into the Super-Emitter Program Portal: "I certify that the information provided in this report regarding the specified super-emitter event was prepared under my direction or supervision. I further certify that the investigations were conducted, and this report was prepared pursuant to the requirements of § 60.5371c (a) and (b). Based on my professional knowledge and experience, and inquiry of personnel involved in the assessment, the certification submitted herein is true, accurate, and complete. I am aware that knowingly false statements may be punishable by fine or imprisonment."

§ 60.5390c What GHG standards apply to gas well liquids unloading operations at well designated facilities?

(a) *General requirements.* You must comply with the requirements of this section for each gas well liquids unloading operation at your gas well designated facility as specified by paragraphs (a)(1) and (2) of this section. You have a general duty to safely maximize resource recovery and minimize releases to the atmosphere during gas well liquids unloading operations.

(1) If a gas well liquids unloading operation technology or technique employed does not result in venting of methane emissions to the atmosphere, you must comply with the requirements specified in paragraphs (a)(1)(A) and (B) of this section. If an unplanned venting event occurs, you must meet the

requirements specified in paragraphs (c) through (f) of this section.

(A) Comply with the recordkeeping requirements specified in § 60.5420c(c)(1)(i).

(B) Submit the information specified in § 60.5420c(b)(1) and (2)(i) in the annual report.

(2) If a gas well liquids unloading operation technology or technique vents methane emissions to the atmosphere, you must comply with the requirements specified in paragraphs (b) and (c), or paragraph (g) of this section.

(b) *Work Practice Standards.* If a gas well liquids unloading operation employs a technology or technique that vents methane emissions to the atmosphere, you must comply with the requirements in paragraphs (b)(1) through (3) and paragraphs (c) through (f) of this section.

(1) Employ best management practices to minimize venting of methane emissions as specified in paragraph (c) of this section for each gas well liquids unloading operation.

(2) Comply with the recordkeeping requirements specified in § 60.5420c(c)(1)(ii).

(3) Submit the information specified in § 60.5420c(b)(1) and (2)(ii) in the annual report.

(c) *Best management practice requirements.* For each gas well liquids unloading operation complying with paragraphs (a)(2) and (b) of this section, you must develop, maintain, and follow a best management practice plan to minimize venting of methane emissions to the maximum extent possible from each gas well liquids unloading operation. This best management practice plan must meet the minimum criteria specified in paragraphs (c)(1) through (4) of this section.

(1) Include steps that create a differential pressure to minimize the need to vent a well to unload liquids,

(2) Include steps to reduce wellbore pressure as much as possible prior to opening the well to the atmosphere,

(3) Unload liquids through the separator where feasible, and

(4) Close all wellhead vents to the atmosphere and return the well to production as soon as practicable.

(d) *Initial compliance.* You must demonstrate initial compliance with the standards that apply to well liquids unloading operations at your well designated facilities as required by § 60.5410c(a).

(e) *Continuous compliance.* You must demonstrate continuous compliance with the standards that apply to well liquids unloading operations at your well designated facilities as required by § 60.5415c(a).

(f) *Recordkeeping and recording.* You must perform the required notification, recordkeeping and reporting requirements as specified in § 60.5420c(b)(2) and (c)(1).

(g) *Other compliance options.* Reduce methane emissions from well designated facilities gas wells that unload liquids by 95.0 percent by complying with the requirements specified in paragraphs (g)(1) and (2) of this section and meeting the initial and continuous compliance and recordkeeping and reporting requirements specified in paragraphs (g)(3) through (5) of this section.

(1) You must route emissions through a closed vent system to a control device that meets the conditions specified in § 60.5412c.

(2) You must route emissions through a closed vent system that meets the requirements of § 60.5411c(a) and (c).

(3) You must demonstrate initial compliance with standards that apply to well designated facility gas well liquids unloading as required by § 60.5410c(b).

(4) You must demonstrate continuous compliance with standards that apply to well designated facility gas well liquids unloading as required by § 60.5415c(b).

(5) You must perform the reporting as required by § 60.5420c(b)(1), (2), and (10) through (12), as applicable; and the recordkeeping as required by § 60.5420c(c)(1), (7), and (9) through (12), as applicable.

§ 60.5391c What GHG standards apply to associated gas wells at well designated facilities?

(a) You must comply with either paragraph (a)(1), (2), (3), or (4) of this section for each associated gas well, except as provided in paragraphs (b), (c), and (d) of this section. You must also comply with paragraphs (f), (g), and (h) of this section.

(1) Recover the associated gas from the separator and route the recovered gas into a gas gathering flow line or collection system to a sales line.

(2) Recover the associated gas from the separator and use the recovered gas as an onsite fuel source.

(3) Recover the associated gas from the separator and use the recovered gas for another useful purpose that a purchased fuel or raw material would serve.

(4) Recover the associated gas from the separator and reinject the recovered gas into the well or inject the recovered gas into another well.

(b) If you meet one of the conditions in paragraphs (b)(1) or (2) of this section, you may route the associated gas to a control device that reduces methane emissions by at least 95.0

percent instead of complying with paragraph (a) of this section. The associated gas must be routed through a closed vent system that meets the requirements of § 60.5411c(a) and (c) and the control device must meet the conditions specified in § 60.5412c(a), (b), and (c).

(1) If the annual methane contained in the associated gas from your oil well is 40 tons per year or less at the initial compliance date, determined in accordance with paragraph (e) of this section.

(2) If you demonstrate and certify that it is not feasible to comply with paragraph (a)(1), (2), (3), and (4) of this section due to technical reasons by providing a detailed analysis documenting and certifying the technical reasons for this infeasibility in accordance with paragraphs (b)(2)(i) through (iv) of this section.

(i) In order to demonstrate that it is not feasible to comply with paragraph (a)(1), (2), (3), and (4) of this section, you must provide a detailed analysis documenting and certifying the technical reasons for this infeasibility. The demonstration must address the technical infeasibility for all options identified in (a)(1), (2), (3), and (4) of this section. Documentation of these demonstrations must be maintained in accordance with § 60.5420c(c)(2)(ii).

(ii) This demonstration must be certified by a professional engineer or another qualified individual with expertise in the uses of associated gas. The following certification, signed and dated by the qualified professional engineer or other qualified individual shall state: "I certify that the assessment of technical and safety infeasibility was prepared under my direction or supervision. I further certify that the assessment was conducted, and this report was prepared pursuant to the requirements of § 60.5391c(b)(1). Based on my professional knowledge and experience, and inquiry of personnel involved in the assessment, the certification submitted herein is true, accurate, and complete."

(iii) This demonstration and certification are valid for no more than 12 months. You must re-analyze the feasibility of complying with paragraphs (a)(1), (2), (3), and (4) of this section and finalize a new demonstration and certification each year.

(iv) Documentation of these demonstrations, along with the certifications, must be maintained in accordance with § 60.5420c(c)(3)(ii) and submitted in annual reports in accordance with § 60.5420c(b)(3).

(c) If you are complying with paragraph (a) of this section, you may

temporarily route the associated gas to a flare or control device in the situations and for the durations identified in paragraphs (c)(1), (2), (3), or (4) of this section. The associated gas must be routed through a closed vent system that meets the requirements of § 60.5411c(a) and (c) and the control device must meet the conditions specified in § 60.5412c(a), (b) and (c). If you are routing to a flare, you must demonstrate that the § 60.18 flare requirements are met during the period when the associated gas is routed to the flare. Records must be kept of all temporary flaring instances in accordance with § 60.5420c(c)(3) and reported in the annual report in accordance with § 60.5420c(b)(3).

(1) For equal to or less than 24 hours during a deviation caused by malfunction causing the need to flare.

(2) For equal to or less than 24 hours during repair, maintenance including blow downs, a bradenhead test, a packer leakage test, a production test, or commissioning.

(3) For (a)(1) and (b)(1) of this section, through the duration of a temporary interruption in service from the gathering or pipeline system, or 30 days, whichever is less.

(4) For 72 hours from the time that the associated gas does not meet pipeline specifications, or until the associated gas meets pipeline specifications, whichever is less.

(d) If you are complying with paragraph (a), (b), or (c) of this section, you may vent the associated gas in the

situations and for the durations identified in paragraphs (d)(1), (2), or (3) of this section. Records must be kept of all venting instances in accordance with § 60.5420c(c)(3) and reported in the annual report in accordance with § 60.5420c(b)(3).

(1) For up to 12 hours to protect the safety of personnel.

(2) For up to 30 minutes during bradenhead monitoring.

(3) For up to 30 minutes during a packer leakage test.

(e) Calculate the methane content in associated gas as specified in paragraph (e)(1) of this section and comply with paragraphs (e)(2) and (e)(3) of this section.

(1) Calculate the methane content in associated gas from your oil well using the following equation

Equation 1 to paragraph (e)(1)

$$AG_{\text{methane}} = \frac{(GOR \times V \times M_{\text{methane}} \times 0.0192)}{907.2}$$

Where:

AG_{methane} = Amount of methane in associated gas from the oil well, tons methane per year

GOR = Gas to oil ratio for the well in standard cubic feet of gas per barrel of oil; oil here refers to hydrocarbon liquids produced of all API gravities. GOR is to be determined for the well using available data, an appropriate standard method published by a consensus-based standards organization which include, but are not limited to, the following: ASTM International, the American National Standards Institute (ANSI), the American Gas Association (AGA), the American Society of Mechanical Engineers (ASME), the American Petroleum Institute (API), and the North American Energy Standards Board (NAESB), or in industry standard practice.

V = Volume of oil produced in the calendar year preceding the initial compliance date, in barrels per year.

M_{methane} = mole fraction of methane in the associated gas.

0.0192 = density of methane gas at 60 °F and

14.7 psia in kilograms per cubic foot

907.2 = conversion of kilograms to tons, kilograms per ton

(2) You must maintain records of the calculation of the methane in associated gas from your oil well results in accordance with § 60.5410c(c)(3), and submit the information, as well as the background information, in the next annual report in accordance with § 60.5410c(b)(3).

(3) If a process change occurs that could increase the methane content in the associated gas, you must recalculate

the methane content in accordance with paragraph (a)(d)(1) of this section.

(f) You must demonstrate initial compliance with the standards that apply to associated gas wells at well designated facilities as required by § 60.5410c(b).

(g) You must demonstrate continuous compliance with the standards that apply to associated gas wells at well designated facilities as required by § 60.5415c(b)(3).

(h) You must perform the required recordkeeping and reporting as required by § 60.5420c(b)(3), (10) and (11), as applicable, and § 60.5420c(c)(2) and (7) and (9) through (12), as applicable.

§ 60.5392c What GHG standards apply to centrifugal compressor designated facilities?

Each centrifugal compressor designated facility must comply with the GHG standards in paragraphs (a) through (d) of this section.

(a) Each centrifugal compressor designated facility that is a wet seal centrifugal compressor, each self-contained wet seal centrifugal compressor, and each Alaska North Slope centrifugal compressor equipped with sour seal oil separator and capture system, must comply with the GHG standards, using volumetric flow rate as a surrogate, as specified in paragraphs (a)(1) and (2) of this section. Each centrifugal compressor designated facility that is a dry seal centrifugal compressor must comply with the GHG standards, using volumetric flow rate as

a surrogate, as specified in paragraphs (a)(1) and (2) of this section, and either paragraph (a)(4) or (5) of this section. Alternatively, you have the option of complying with the GHG standards for your wet seal and dry seal centrifugal compressor by meeting the requirements specified in paragraph (a)(3), and either paragraph (a)(4) or (5) of this section.

(1) If you utilize a centrifugal compressor, you must comply with the GHG standards in paragraph (a)(1)(i) through (iii) of this section, and the seal repair requirements of paragraph (a)(1)(iv) of this section.

(i) You must conduct volumetric flow rate measurements from each wet seal centrifugal compressor (including each self-contained wet seal centrifugal compressor) vent using the methods specified in paragraph (a)(2) of this section and in accordance with the schedule specified in paragraphs (a)(1)(i)(A) and (B) of this section. The volumetric flow rate, measured in accordance with paragraph (a)(2) of this section, must not exceed 3 standard cubic feet per minute (scfm) per seal. If the individual seals are manifolded to a single open-vented line, the volumetric flow rate must not exceed the sum of the individual seals multiplied by 3 scfm. If the volumetric flow rate exceeds 3 scfm multiplied by the number of seals connected to the vent, the seals connected to the measured vent must be repaired as provided in paragraph (a)(1)(iv) of this section.

(A) You must conduct your first volumetric flow rate measurement from your wet seal centrifugal compressor (including self-contained wet seal centrifugal compressors) vents on or before 8,760 hours of operation 36 months after the state plan submittal deadline (as specified in § 60.5362c(c)), or on or before 8,760 hours of operation after startup, whichever date is later.

(B) You must conduct subsequent volumetric flow rate measurements from your wet seal centrifugal compressor (including self-contained wet seal centrifugal compressor) vents on or before 8,760 hours of operation after the previous measurement.

(ii) You must conduct volumetric flow rate measurements from each Alaska North Slope centrifugal compressor equipped with sour seal oil separator and capture system using the methods specified in paragraph (a)(2) of this section and in accordance with the schedule specified in paragraphs (a)(1)(ii)(A) and (B) of this section. The volumetric flow rate, measured in accordance with paragraph (a)(2) of this section, must not exceed 9 standard cubic feet per minute (scfm) per seal. If the individual seals are manifolded to a single open-vented line, the volumetric flow rate must not exceed the sum of the individual seals multiplied by 9 scfm. If the volumetric flow rate exceeds 9 scfm multiplied by the number of seals connected to the vent, the seals connected to the measured vent must be repaired as provided in paragraph (a)(1)(iv) of this section.

(A) You must conduct your first volumetric flow rate measurement from your centrifugal compressor equipped with sour seal oil separator and capture system utilized in Alaska wet seal vent on or before 8,760 hours of operation 36 months after the state plan submittal deadline (as specified in § 60.5362c(c)), or on or before 8,760 hours of operation after startup, whichever date is later.

(B) You must conduct subsequent volumetric flow rate measurements from your centrifugal compressor wet seal vents on or before 8,760 hours of operation after the previous measurement.

(iii) You must conduct volumetric flow rate vent measurements from each centrifugal compressor equipped with dry seals using the methods specified in paragraph (a)(2) of this section and in accordance with the schedule specified in paragraphs (a)(1)(iii)(A) and (B) of this section. The volumetric flow rate, measured in accordance with paragraph (a)(2) of this section, must not exceed 10 standard cubic feet per minute (scfm) per seal. If the individual seals are manifolded to a single open-vented line,

the volumetric flow rate must not exceed the sum of the individual seals multiplied by 10 scfm. If the volumetric flow rate exceeds 10 scfm multiplied by the number of seals connected to the vent, the seals connected to the measured vent must be repaired as provided in paragraph (a)(1)(iv) of this section.

(A) You must conduct your first volumetric flow rate vent measurement from your centrifugal compressor equipped with a dry seal on or before 8,760 hours of operation 36 months after the state plan submittal deadline (as specified in § 60.5362c(c)), or on or before 8,760 hours of operation after startup, whichever date is later.

(B) You must conduct subsequent volumetric flow rate vent measurements from your centrifugal compressor equipped with a dry seal on or before 8,760 hours of operation after the previous measurement.

(iv) The seal must be repaired within 90 calendar days after the date of the volumetric emissions measurement that exceeds the applicable required flow rate per seal. You must conduct follow-up volumetric flow rate measurements from seal vents using the methods specified in paragraph (a)(2) of this section within 15 days after the repair to document that the rate has been reduced to less than the applicable required flow rate per seal. If the individual seals are manifolded to a single open-ended line or vent, the volumetric flow rate must be reduced to less than the sum of the individual seals multiplied by the applicable required flow rate per seal specified in paragraph (a)(1)(i) through (iii) of this section, as applicable. Delay of repair will be allowed if the conditions in paragraphs (a)(1)(iv)(A) or (B) of this section are met.

(A) If the repair of the wet or dry seal is technically infeasible, would require a vent blowdown, a compressor station shutdown, or would be unsafe to repair during operation of the unit, the repair must be completed during the next scheduled compressor station shutdown for maintenance, after a scheduled vent blowdown, or within 2 years of the date of the volumetric emissions measurement that exceeds the applicable required flow rate per seal, whichever is earliest. A vent blowdown is the opening of one or more blowdown valves to depressurize major production and processing equipment, other than a storage vessel.

(B) If the repair requires replacement of the compressor seal or a part thereof, but the replacement seal or part cannot be acquired and installed within the repair timelines specified under this

section due to the condition specified in paragraph (a)(1)(iv)(B)(1) of this section, the repair must be completed in accordance with paragraph (a)(1)(iv)(B)(2) of this section and documented in accordance with § 60.5420c(c)(3)(iii)(F) through (H).

(1) Seal or part thereof supplies had been sufficiently stocked but are depleted at the time of the required repair.

(2) The required replacement seal or part must be ordered no later than 10 calendar days after the centrifugal compressor is added to the delay of repair list due to parts unavailability. The repair must be completed as soon as practicable, but no later than 30 calendar days after receipt of the replacement seal or part, unless the repair requires a compressor station shutdown. If the repair requires a compressor station shutdown, the repair must be completed in accordance with the timeframe specified in paragraph (a)(1)(iv)(A) of this section.

(2) You must determine the volumetric flow rates from your centrifugal compressor dry or wet seal vents as specified in paragraph (a)(2)(i) or (ii) of this section.

(i) For each dry or wet seal centrifugal compressor in operating-mode or in standby-pressurized-mode, determine volumetric flow rate at standard conditions from each dry or wet seal vent using one of the methods specified in paragraphs (a)(2)(i)(A) through (C) of this section.

(A) You may choose to use any of the methods set forth in § 60.5405c(a) to screen for leaks/emissions. For the purposes of this paragraph, when using any of the methods in § 60.5405c(a), emissions are detected whenever a leak is detected according to the method. If emissions are detected using the methods set forth in § 60.5405c(a), then you must use one of the methods specified in paragraph (a)(2)(i)(B) or (C) of this section to determine the volumetric flow rate. If emissions are not detected using the methods in § 60.5405c(a), then you may assume that the volumetric flow rate is zero.

(B) Use a temporary or permanent flow meter according to methods set forth in § 60.5405c(b).

(C) Use a high-volume sampler according to the methods set forth in § 60.5405c(c).

(ii) For conducting measurements on manifolded groups of dry or wet seal centrifugal compressors, you must determine the volumetric flow rate from the compressor dry or wet seal as specified in paragraph (a)(2)(ii)(A) or (B) of this section.

(A) Measure at a single point in the manifold downstream of all dry or wet seal compressor inputs and, if practical, prior to comingling with other non-compressor emission sources.

(B) Determine the volumetric flow rate at standard conditions from the common stack using one of the methods specified in paragraph (a)(2)(i)(A) through (C) of this section.

(3) As an alternative to meeting the requirements of paragraphs (a)(1) and (2) of this section for compressors with wet seals and dry seals, you have the option of reducing methane emissions from each centrifugal compressor wet seal fluid degassing system by 95.0 percent by meeting the requirements of paragraph (a)(4) of this section, or the option of routing the emissions from each centrifugal compressor wet seal fluid degassing system or dry seal system to a process by meeting the requirements of paragraph (a)(5) of this section.

(4) If you use a control device to reduce methane emissions by 95.0 percent, you must equip the wet seal fluid degassing system with a cover that meets the requirements of § 60.5411c(b). The cover must be connected through a closed vent system that meets the requirements of § 60.5411c(a) and (c) and the closed vent system must be routed to a control device that meets the conditions specified in § 60.5412c.

(5) If you route the emissions to a process, you must equip the wet seal fluid degassing system or dry seal system with a cover that meets the requirements of § 60.5411c(b). The cover must be connected through a closed vent system that meets the requirements of § 60.5411c(a) and (c).

(b) You must demonstrate initial compliance with the standards that apply to centrifugal compressor designated facilities as required by § 60.5410c(c).

(c) You must demonstrate continuous compliance with the standards that apply to centrifugal compressor designated facilities as required by § 60.5415c(c).

(d) You must perform the reporting as required by § 60.5420c(b)(1) and (4) and (b)(10) through (12), as applicable; and the recordkeeping as required by § 60.5420c(c)(3) and (c)(7) through (12), as applicable.

§ 60.5393c What GHG standards apply to reciprocating compressor designated facilities?

Each reciprocating compressor designated facility must comply with the GHG standards, using volumetric flow rate as a surrogate, in paragraphs (a) through (c) of this section, or the

GHG standards in paragraph (d) of this section. You must also comply with the requirements in paragraphs (e) through (g) of this section.

(a) The volumetric flow rate of each cylinder, measured in accordance with paragraph (b) or (c) of this section, must not exceed 2 scfm per individual cylinder. If the individual cylinders are manifolded to a single open-ended vent line, the volumetric flow rate must not exceed the sum of the individual cylinders multiplied by 2 scfm. You must conduct measurements of the volumetric flow rate in accordance with the schedule specified in paragraphs (a)(1) and (2) of this section and determine the volumetric flow rate per cylinder in accordance with paragraph (b) or (c) of this section. If the volumetric flow rate, measured in accordance with paragraph (b) or (c) of this section, for a cylinder exceeds 2 scfm per cylinder (or a combined volumetric flow rate greater than the number of compression cylinders multiplied by 2 scfm), the rod packing or packings must be repaired or replaced as provided in paragraph (a)(3) of this section.

(1) You must conduct your first volumetric flow rate measurements from your reciprocating compressor rod packing vent on or before 8,760 hours of operation after the effective date of an approved state or Tribal plan, on or before 8,760 hours of operation after last rod packing replacement, or on or before 8,760 hours of operation after startup, whichever date is later.

(2) You must conduct subsequent volumetric flow rate measurements from your reciprocating compressor rod packing vent on or before 8,760 hours of operation after the previous measurement which demonstrates compliance with the applicable volumetric flow rate of 2 scfm per cylinder (or a combined cylinder volumetric flow rate greater than the number of compression cylinders multiplied by 2 scfm), or on or before 8,760 hours of operation after last rod packing replacement, whichever date is later.

(3) The rod packing must be repaired or replaced within 90 calendar days after the date of the volumetric emissions measurement that exceeded 2 scfm per cylinder. You must conduct follow-up volumetric flow rate measurements from compressor vents using the methods specified in paragraph (b) of this section within 15 days after the repair (or rod packing replacement) to document that the rate has been reduced to less than 2 scfm per cylinder. Delay of repair will be allowed

if the conditions in paragraphs (a)(3)(i) or (ii) of this section are met.

(i) If the repair (or rod packing replacement) is technically infeasible, would require a vent blowdown, a compressor station shutdown, or would be unsafe to repair during operation of the unit, the repair (or rod packing replacement) must be completed during the next scheduled compressor station shutdown for maintenance, after a scheduled vent blowdown, or within 2 years of the date of the volumetric emissions measurement that exceeds the applicable required flow rate per cylinder, whichever is earliest. A vent blowdown is the opening of one or more blowdown valves to depressurize major production and processing equipment, other than a storage vessel.

(ii) If the repair requires replacement of the rod packing or a part, but the replacement cannot be acquired and installed within the repair timelines specified under this section due to the condition specified in paragraph (a)(3)(ii)(A) of this section, the repair must be completed in accordance with paragraph (a)(3)(ii)(B) of this section and documented in accordance with § 60.5420c(c)(4)(viii) through (x).

(A) Rod packing or part supplies had been sufficiently stocked but are depleted at the time of the required repair.

(B) The required rod packing or part replacement must be ordered no later than 10 calendar days after the reciprocating compressor is added to the delay of repair list due to parts unavailability. The repair must be completed as soon as practicable, but no later than 30 calendar days after receipt of the replacement rod packing or part, unless the repair requires a compressor station shutdown. If the repair requires a compressor station shutdown, the repair must be completed in accordance with the timeframe specified in paragraph (a)(3)(i) of this section.

(b) You must determine the volumetric flow rate per cylinder from your reciprocating compressor as specified in paragraph (b)(1) or (2) of this section.

(1) For reciprocating compressor rod packing equipped with an open-ended vent line on compressors in operating or standby pressurized mode, determine the volumetric flow rate of the rod packing using one of the methods specified in paragraphs (b)(1)(i) through (iii) of this section.

(i) Determine the volumetric flow rate at standard conditions from the open-ended vent line using a high-volume sampler according to methods set forth in § 60.5405c(c).

(ii) Determine the volumetric flow rate at standard conditions from the open-ended vent line using a temporary or permanent meter, according to methods set forth in § 60.5405c(b).

(iii) Any of the methods set forth in § 60.5405c(a) to screen for leaks and emissions. For the purposes of this paragraph, emissions are detected whenever a leak is detected according to any of the methods in § 60.5405c(a). If emissions are detected using the methods set forth in § 60.5405c(a), then you must use one of the methods specified in paragraph (b)(1)(i) and (ii) of this section to determine the volumetric flow rate per cylinder. If emissions are not detected using the methods in § 60.5405c(a), then you may assume that the volumetric flow rate is zero.

(2) For reciprocating compressor rod packing not equipped with an open-ended vent line on compressors in operating or standby pressurized mode, you must determine the volumetric flow rate of the rod packing using the methods specified in paragraphs (b)(2)(i) and (ii) of this section.

(i) You must use the methods described in § 60.5405c(a) to conduct leak detection of emissions from the rod packing case into an open distance piece, or, for compressors with a closed distance piece, you must conduct annual leak detection of emissions from the rod packing vent, distance piece vent, compressor crank case breather cap, or other vent emitting gas from the rod packing.

(ii) You must measure emissions found in paragraph (b)(2)(i) of this section using a meter or high-volume sampler according to methods set forth in § 60.5405c(b) or (c).

(c) For conducting measurements on manifolded groups of reciprocating compressor designated facilities, you must determine the volumetric flow rate from reciprocating compressor rod packing vent as specified in paragraph (c)(1) and (2) of this section.

(1) Measure at a single point in the manifold downstream of all compressor vent inputs and, if practical, prior to comingling with other non-compressor emission sources.

(2) Determine the volumetric flow rate per cylinder at standard conditions from the common stack using one of the methods specified in paragraph (c)(2)(i) through (iv) of this section.

(i) A temporary or permanent flow meter according to the methods set forth in § 60.5405c(b).

(ii) A high-volume sampler according to methods set forth § 60.5405c(c).

(iii) An alternative method, as set forth in § 60.5405c(d).

(iv) Any of the methods set forth in § 60.5405c(a) to screen for emissions. For the purposes of this paragraph, emissions are detected whenever a leak is detected when using any of the methods in § 60.5405c(a). If emissions are detected using the methods set forth in § 60.5405c(a), then you must use one of the methods specified in paragraph (c)(2)(i) through (iii) of this section to determine the volumetric flow rate per cylinder. If emissions are not detected using the methods in § 60.5405c(a), then you may assume that the volumetric flow rate is zero.

(d) As an alternative to complying with the GHG standards in paragraphs (a) through (c) of this section, owners or operators can meet the requirements specified in paragraph (d)(1), (2), or (3) of this section.

(1) Collect the methane emissions from your reciprocating compressor rod packing using a rod packing emissions collection system that is operated to route the rod packing emissions to a process. In order to comply with this option, you must equip the reciprocating compressor with a cover that meets the requirements of § 60.5411c(b). The cover must be connected through a closed vent system that meets the requirements of § 60.5411c(a) and (c).

(2) Reduce methane emissions from each rod packing emissions collection system by using a control device that reduces methane emissions by 95.0 percent. In order to comply with this option, you must equip the reciprocating compressor with a cover that meets the requirements of § 60.5411c(b). The cover must be connected through a closed vent system that meets the requirements of § 60.5411c(a) and (c) and the closed vent system must be routed to a control device that meets the conditions specified in § 60.5412c.

(3) As an alternative to conducting the required volumetric flow rate measurements under paragraph (a) of this section, an owner or operator can choose to comply by replacing the rod packing on or before 8,760 hours of operation after the effective date of the final rule, on or before 8,760 hours of operation after the previous flow rate measurement, or on or before 8,760 hours of operation after the date of the most recent compressor rod packing replacement, whichever date is later.

(e) You must demonstrate initial compliance with standards that apply to reciprocating compressor designated facilities as required by § 60.5410c(d).

(f) You must demonstrate continuous compliance with standards that apply to

reciprocating compressor designated facilities as required by § 60.5415c(f).

(g) You must perform the reporting requirements as specified in § 60.5420c(b)(1), (5), (10), and (11), as applicable; and the recordkeeping requirements as specified in § 60.5420c(c)(4) and (7) through (11), as applicable.

§ 60.5394c What GHG standards apply to process controller designated facilities?

Each process controller designated facility must comply with the GHG standards in this section.

(a) You must design and operate each process controller designated facility with zero methane emissions to the atmosphere, except as provided in paragraph (b) of this section.

(1) If you comply by routing the emissions to a process, emissions must be routed to a process through a closed vent system.

(2) If you comply by using a self-contained natural gas-driven process controller, you must design and operate each self-contained natural gas-driven process controller with no identifiable emissions, as demonstrated by § 60.5416c(b).

(b) For each process controller designated facility located at a site in Alaska that does not have access to electrical power, you may comply with either paragraphs (b)(1) and (2) of this section or with paragraph (b)(3) of this section, instead of complying with paragraph (a) of this section.

(1) With the exception of natural gas-driven continuous bleed controllers that meet the condition in paragraph (b)(1)(i) of this section and that comply with paragraph (b)(1)(ii) of this section, each natural gas-driven continuous bleed process controller in the process controller designated facility must have a bleed rate less than or equal to 6 standard cubic feet per hour (scfh).

(i) A natural gas-driven continuous bleed process controller with a bleed rate higher than 6 scfh may be used if the requirements of paragraph (b)(1)(ii) of this section are met.

(ii) You demonstrate that a natural gas-driven continuous bleed controller with a bleed rate higher than 6 scfh is required. The demonstration must be based on the specific functional need, including but not limited to response time, safety, or positive actuation.

(2) Each natural gas-driven intermittent vent process controller in the process controller designated facility must comply with the requirements in paragraphs (b)(2)(i) and (ii) of this section.

(i) Each natural gas-driven intermittent vent process controller

must not emit to the atmosphere during idle periods.

(ii) You must monitor each natural gas-driven intermittent vent process controller to ensure that it is not emitting to the atmosphere during idle periods, as specified in paragraphs (b)(2)(ii)(A) through (C) of this section.

(A) Monitoring must be conducted at the same frequency as specified for fugitive emissions components designated facilities located at the same type of site, as specified in § 60.5397c(g).

(B) You must include the monitoring of each natural gas-driven intermittent vent process controller in the monitoring plan required in § 60.5397c(b).

(C) When monitoring identifies emissions to the atmosphere from a natural gas-driven intermittent vent controller during idle periods, you must take corrective action by repairing or replacing the natural gas-driven intermittent vent process controller within 5 calendar days of the date the emissions to the atmosphere were detected. After the repair or replacement of a natural gas-driven intermittent vent process controller, you must re-survey the natural gas-driven intermittent vent process controller within five days to verify that it is not venting emissions during idle periods.

(3) You must reduce methane emissions from all controllers in the process controller designated facility by 95.0 percent. You must route emissions through a closed vent system to a control device through a closed vent system that meets the conditions specified in § 60.5412c.

(c) If you route process controller emissions to a process or a control device, you must route the process controller designated facility emissions through a closed vent system that meets the requirements of § 60.5411c(a) and (c).

(d) You must demonstrate initial compliance with standards that apply to process controller designated facilities as required by § 60.5410c(e).

(e) You must demonstrate continuous compliance with standards that apply to process controller designated facilities as required by § 60.5415c(g).

(f) You must perform the reporting as required by § 60.5420c(b)(1), (6) and (10) through (12), as applicable, and the recordkeeping as required by § 60.5420c(c)(5), (7), and (9) through (12), as applicable.

§ 60.5395c What GHG standards apply to pump designated facilities?

Each pump designated facility, you must comply with the GHG standards in this section.

(a) For each pump designated facility meeting the criteria specified in paragraphs (a)(1) or (2) of this section, you must design and operate the pump designated facility with zero methane emissions to the atmosphere. If you comply by routing the pump designated facility emissions to a process, the emissions must be routed to the process through a closed vent system.

(1) The pump designated facility is located at a site that has access to electrical power.

(2) The pump designated facility is located at a site that does not have access to electrical power and also has three or more natural gas-driven diaphragm pumps.

(b)(1) For each pump designated facility located at a site that does not have access to electrical power and that also has fewer than three natural gas-driven diaphragm pumps, you must comply with paragraph (b)(2) or (3) of this section, except as provided in paragraphs (b)(4) through (8) of this section.

(2) Emissions from the pump designated facility must be routed through a closed vent system to a process if a vapor recovery unit is onsite.

(3) If a vapor recovery unit is not onsite, you must reduce methane emissions from the pump designated facility by 95.0 percent. You must route designated pump facility emissions through a closed vent system to a control device meeting the conditions specified in § 60.5412c.

(4) You are not required to install an emissions control device or a vapor recovery unit, if such a unit is necessary to enable emissions to be routed to a process, solely for the purpose of complying with the requirements of paragraphs (b)(2) or (3) of this section. If no control device capable of achieving a 95.0 percent emissions reduction and no vapor recovery unit is present on site, you must comply with paragraph (b)(5) or (6) of this section, as applicable. For the purposes of this section, boilers and process heaters are not considered to be control devices.

(5) If an emissions control device is on site but is unable to achieve a 95.0 percent emissions reduction, you must route the pump designated facility emissions through a closed vent system to that control device. You must certify that there is no vapor recovery unit on site and that there is no control device

capable of achieving a 95.0 percent emissions reduction on site.

(6) If there is no vapor recovery unit on site and no emission control device is on site, you must certify that there is no vapor recovery unit or emissions control device on site. If you subsequently install a control device or vapor recovery unit, you must meet the requirements of paragraphs (b)(6)(i) and (ii) of this section.

(i) You must be in compliance with the requirements of paragraphs (b)(1) through (3) of this section, as applicable, within 30 days of startup of the control device or vapor recovery unit.

(ii) You must maintain the records in § 60.5420c(c)(14)(ii) and (v), as applicable. You are no longer required to maintain the records in § 60.5420c(c)(14)(vi).

(7) If an owner or operator complying with paragraph (b)(1) of this section determines, through an engineering assessment, that routing the pump designated facility emissions to a control device or to a process is technically infeasible, the requirements specified in paragraphs (b)(7)(i) through (iii) of this section must be met.

(i) The owner or operator must conduct the assessment of technical infeasibility in accordance with the criteria in paragraph (b)(7)(ii) of this section and have it certified by either a qualified professional engineer or an in-house engineer with expertise on the design and operation of the pump designated facility and the control device or processes at the site in accordance with paragraph (b)(7)(iii) of this section.

(ii) The assessment of technical infeasibility to route emissions from the pump designated facility to an existing control device or process must include, but is not limited to, safety considerations, distance from the control device or process, pressure losses and differentials in the closed vent system, and the ability of the control device or process to handle the pump designated facility emissions which are routed to them. The assessment of technical infeasibility must be prepared under the direction or supervision of the qualified professional engineer or in-house engineer who signs the certification in accordance with paragraph (b)(7)(iii) of this section.

(iii) The following certification, signed and dated by the qualified professional engineer or in-house engineer, must state: "I certify that the assessment of technical infeasibility was prepared under my direction or supervision. I further certify that the assessment was conducted and this report was prepared pursuant to the

requirements of § 60.5395c(b)(5)(ii). Based on my professional knowledge and experience, and inquiry of personnel involved in the assessment, the certification submitted herein is true, accurate, and complete.”

(8) If the pump designated facility emissions are routed to a control device or process and the control device or process is subsequently removed from the location or is no longer available such that there is no option to route to a control device or process, you are no longer required to be in compliance with the requirements of paragraph (b)(2) or (3) of this section, and instead must comply with paragraph (b)(6) of this section.

(c) If you use a control device or route to a process to reduce emissions, you must route the pump designated facility emissions through a closed vent system that meets the requirements of § 60.5411c(a) and (c).

(d) You must demonstrate initial compliance with standards that apply to pump designated facilities as required by § 60.5410c(f).

(e) You must demonstrate continuous compliance with the standards that apply to pump designated facilities as required by § 60.5415c(d).

(f) You must perform the reporting as required by § 60.5420c(b)(1), (9), and (b)(10) through (12), as applicable, and the recordkeeping as required by § 60.5420c(c)(7), (c)(9) through (12), and (14), as applicable.

§ 60.5396c What GHG standards apply to storage vessel designated facilities?

Each storage vessel designated facility must comply with the GHG standards in this section, except as provided in paragraph (e) of this section.

(a) *General requirements.* You must comply with the requirements of paragraphs (a)(1) and (2) of this section. After 12 consecutive months of compliance with paragraph (a)(2) of this section, you may continue to comply with paragraph (a)(2) of this section, or you may comply with paragraph (a)(3) of this section, if applicable. If you choose to meet the requirements of paragraph (a)(3) of this section, you are not required to comply with the requirements of paragraph (a)(2) of this section except as provided in paragraphs (a)(3)(i) and (ii) of this section.

(1) Determine the potential for methane emissions in accordance with § 60.5386c(e)(2).

(2) Reduce methane emissions by 95.0 percent.

(3) Maintain the uncontrolled actual methane emissions from the storage vessel designated facility at less than 14

tpy without considering control in accordance with paragraphs (a)(3)(i) through (iii) of this section. Prior to using the uncontrolled actual methane emission rates for compliance purposes, you must demonstrate that the uncontrolled actual methane emissions have remained less than 14 tpy as determined monthly for 12 consecutive months. After such demonstration, you must determine the uncontrolled actual rolling 12-month determination methane emissions rates each month. The uncontrolled actual methane emissions must be calculated using a generally accepted model or calculation methodology which account for flashing, working, and breathing losses, and the calculations must be based on the actual average throughput, temperature, and separator pressure for the month. You may no longer comply with this paragraph and must instead comply with paragraph (a)(2) of this section if your storage vessel designated facility meets the conditions specified in paragraphs (a)(3)(i) or (ii) of this section.

(i) If a well feeding the storage vessel designated facility undergoes fracturing or refracturing, you must comply with paragraph (a)(2) of this section as soon as liquids from the well following fracturing or refracturing are routed to the storage vessel designated facility.

(ii) If the rolling 12-month emissions determination required in this section indicates that methane emissions increase to 14 tpy or greater from your storage vessel designated facility and the increase is not associated with fracturing or refracturing of a well feeding the storage vessel designated facility, you must comply with paragraph (a)(2) of this section within 30 days of the monthly determination.

(b) *Control requirements.* (1) Except as required in paragraph (b)(2) of this section, if you use a control device to reduce methane emissions from your storage vessel designated facility, you must meet all of the design and operational criteria specified in paragraphs (b)(1)(i) through (iv) of this section.

(i) Each storage vessel in the tank battery must be equipped with a cover that meets the requirements of § 60.5411c(b);

(ii) The storage vessels must be manifolded together with piping such that all vapors are shared among the headspaces of the storage vessels in the tank battery;

(iii) The tank battery must be equipped with one or more closed vent system that meets the requirements of § 60.5411c(a) and (c); and

(iv) The vapors collected in paragraphs (b)(1)(ii) and (iii) of this section must be routed to a control device that meets the conditions specified in § 60.5412c. As an alternative to routing the closed vent system to a control device, you may route the closed vent system to a process.

(2) For storage vessel designated facilities that do not have flashing emissions and that are not located at well sites or centralized production facilities, you may use a floating roof to reduce emissions. If you use a floating roof to reduce emissions, you must meet the requirements of § 60.112b(a)(1) or (2) and the relevant monitoring, inspection, recordkeeping, and reporting requirements in subpart Kb of this part. You must submit a statement that you are complying with § 60.112b(a)(1) or (2) with the initial annual report specified in § 60.5420c(b)(1) and (7).

(c) *Requirements for storage vessel designated facilities that are removed from service or returned to service.* If you remove a storage vessel designated facility from service or remove a portion of a storage vessel designated facility from service, you must comply with the applicable paragraphs (c)(1) through (4) of this section. A storage vessel is not a designated facility under this subpart for the period that it is removed from service.

(1) For a storage vessel designated facility to be removed from service, you must comply with the requirements of paragraphs (c)(1)(i) and (ii) of this section.

(i) You must completely empty and degas each storage vessel, such that each storage vessel no longer contains crude oil, condensate, produced water or intermediate hydrocarbon liquids. A storage vessel where liquid is left on walls, as bottom clingage or in pools due to floor irregularity is considered to be completely empty.

(ii) You must submit a notification as required in § 60.5420c(b)(7)(viii) in your next annual report, identifying each storage vessel designated facility removed from service during the reporting period and the date of its removal from service.

(2) For a portion of a storage vessel designated facility to be removed from service, you must comply with the requirements of paragraphs (c)(2)(i) through (iv) of this section.

(i) You must completely empty and degas the storage vessel(s), such that the storage vessel(s) no longer contains crude oil, condensate, produced water or intermediate hydrocarbon liquids. A storage vessel where liquid is left on walls, as bottom clingage or in pools

due to floor irregularity is considered to be completely empty.

(ii) You must disconnect the storage vessel(s) from the tank battery by isolating the storage vessel(s) from the tank battery such that the storage vessel(s) is no longer manifolded to the tank battery by liquid or vapor transfer.

(iii) You must submit a notification as required in § 60.5420c(b)(7)(viii) in your next annual report, identifying each storage vessel removed from service during the reporting period, the impacted storage vessel designated facility, and the date of its removal from service.

(iv) The remaining storage vessel(s) in the tank battery remain a storage vessel designated facility and must continue to comply with the applicable requirements of paragraphs (a) and (b) of this section.

(3) If a storage vessel identified in paragraph (c)(1)(ii) or (c)(2)(iii) of this section is returned to service, you must determine its designated facility status as provided in § 60.5386c(e)(5).

(4) For each storage vessel designated facility or portion of a storage vessel designated facility returned to service during the reporting period, you must submit a notification in your next annual report as required in § 60.5420c(b)(7)(ix), identifying each storage vessel designated facility or portion of a storage vessel designated facility and the date of its return to service.

(d) *Compliance, notification, recordkeeping, and reporting.* You must comply with paragraphs (d)(1) through (3) of this section.

(1) You must demonstrate initial compliance with standards as required by § 60.5410c(h).

(2) You must demonstrate continuous compliance with standards as required by § 60.5415c(h).

(3) You must perform the required reporting as required by § 60.5420c(b)(1) and (7) and (b)(10) through (12), as applicable and the recordkeeping as required by § 60.5420c(c)(6) and (c)(7) through (12), as applicable.

(e) *Exemptions.* This subpart does not apply to storage vessels subject to and controlled in accordance with the requirements for storage vessels in subpart Kb of this part, and 40 CFR part 63, subparts G, CC, HH, or WW.

§ 60.5397c What GHG standards apply to fugitive emissions components designated facilities?

This section applies to fugitive emissions components designated facilities. You must comply with the requirements of paragraphs (a) through (l) of this section to reduce fugitive

emissions of methane. The requirements of this section are independent of the cover and closed vent system requirements of § 60.5411c.

(a) *General requirements.* You must monitor all fugitive emissions components in accordance with paragraphs (b) through (g) of this section. You must repair all sources of fugitive emissions in accordance with paragraph (h) of this section. You must demonstrate initial compliance in accordance with paragraph (i) of this section. You must keep records in accordance with paragraph (j) of this section and report in accordance with paragraph (k) of this section. You must meet the requirements for well closures in accordance with paragraph (l) of this section.

(b) *Develop fugitive emissions monitoring plan.* You must develop a fugitive emissions monitoring plan that covers all fugitive emissions components designated facilities within each company-defined area in accordance with paragraphs (c) and (d) of this section.

(c) *Fugitive emissions monitoring plan.* Your fugitive emissions monitoring plan must include the elements specified in paragraphs (c)(1) through (8) of this section, at a minimum.

(1) Frequency for conducting surveys. Surveys must be conducted at least as frequently as required by paragraphs (f) and (g) of this section.

(2) Technique for determining fugitive emissions (*i.e.*, AVO or other detection methods, Method 21 of appendix A-7 to this part; and/or OGI and meeting the requirements of paragraphs (c)(7)(i) through (vii) of this section).

(3) Manufacturer and model number of fugitive emissions detection equipment to be used, if applicable.

(4) Procedures and timeframes for identifying and repairing fugitive emissions components from which fugitive emissions are detected, including timeframes for fugitive emission components that are unsafe to repair. Your repair schedule must meet the requirements of paragraph (h) of this section at a minimum.

(5) Procedures and timeframes for verifying fugitive emission component repairs.

(6) Records that will be kept and the length of time records will be kept.

(7) If you are using OGI, your plan must also include the elements specified in paragraphs (c)(7)(i) through (vii) of this section.

(i) Verification that your OGI equipment meets the specifications of paragraphs (c)(7)(i)(A) and (B) of this section. This verification is an initial

verification, and may either be performed by the facility, by the manufacturer, or by a third party. For the purposes of complying with the fugitive emissions monitoring program with OGI, fugitive emissions are defined as any visible emissions observed using OGI.

(A) Your OGI equipment must be capable of imaging gases in the spectral range for the compound of highest concentration in the potential fugitive emissions.

(B) Your OGI equipment must be capable of imaging a gas that is half methane, half propane at a concentration of 10,000 ppm at a flow rate of ≤60 g/hr from a quarter inch diameter orifice.

(ii) Procedure for a daily verification check.

(iii) Procedure for determining the operator's maximum viewing distance from the equipment and how the operator will ensure that this distance is maintained.

(iv) Procedure for determining maximum wind speed during which monitoring can be performed and how the operator will ensure monitoring occurs only at wind speeds below this threshold.

(v) Procedures for conducting surveys, including the items specified in paragraphs (c)(7)(v)(A) through (C) of this section.

(A) How the operator will ensure an adequate thermal background is present in order to view potential fugitive emissions.

(B) How the operator will deal with adverse monitoring conditions, such as wind.

(C) How the operator will deal with interferences (*e.g.*, steam).

(vi) Training and experience needed prior to performing surveys.

(vii) Procedures for calibration and maintenance. At a minimum, procedures must comply with those recommended by the manufacturer.

(8) If you are using Method 21 of appendix A-7 to this part, your plan must also include the elements specified in paragraphs (c)(8)(i) through (iv) of this section. For the purposes of complying with the fugitive emissions monitoring program using Method 21 of appendix A-7 to this part, a fugitive emission is defined as an instrument reading of 500 ppmv or greater.

(i) *Verification that your monitoring equipment meets the requirements specified in Section 6.0 of Method 21 of appendix A-7 to this part.* For purposes of instrument capability, the fugitive emissions definition shall be 500 ppmv or greater methane using a FID-based instrument. If you wish to use an

analyzer other than a FID-based instrument, you must develop a site-specific fugitive emission definition that would be equivalent to 500 ppmv methane using a FID-based instrument (e.g., 10.6 eV PID with a specified isobutylene concentration as the fugitive emission definition would provide equivalent response to your compound of interest).

(ii) *Procedures for conducting surveys.* At a minimum, the procedures shall ensure that the surveys comply with the relevant sections of Method 21 of appendix A-7 to this part, including Section 8.3.1.

(iii) *Procedures for calibration.* The instrument must be calibrated before use each day of its use by the procedures specified in Method 21 of appendix A-7 to this part. At a minimum, you must also conduct precision tests at the interval specified in Method 21 of appendix A-7 to this part, Section 8.1.2, and a calibration drift assessment at the end of each monitoring day. The calibration drift assessment must be conducted as specified in paragraph (c)(8)(iii)(A) of this section. Corrective action for drift assessments is specified in paragraphs (c)(8)(iii)(B) and (C) of this section.

(A) Check the instrument using the same calibration gas that was used to calibrate the instrument before use. Follow the procedures specified in Method 21 of appendix A-7 to this part, Section 10.1, except do not adjust the meter readout to correspond to the calibration gas value. If multiple scales are used, record the instrument reading for each scale used. Divide the arithmetic difference of the initial and post-test calibration response by the corresponding calibration gas value for each scale and multiply by 100 to express the calibration drift as a percentage.

(B) If a calibration drift assessment shows a negative drift of more than 10 percent, then all equipment with instrument readings between the fugitive emission definition multiplied by (100 minus the percent of negative drift) divided by 100 and the fugitive emission definition that was monitored since the last calibration must be re-monitored.

(C) If any calibration drift assessment shows a positive drift of more than 10 percent from the initial calibration value, then, at the owner/operator's discretion, all equipment with instrument readings above the fugitive emission definition and below the fugitive emission definition multiplied by (100 plus the percent of positive drift) divided by 100 monitored since the last calibration may be re-monitored.

(iv) *Procedures for monitoring yard piping (other than buried yard piping).* At a minimum, place the probe inlet at the surface of the yard piping and run the probe down the length of the piping. Connection points on the piping must be monitored following the procedures specified in Method 21 of appendix A-7 to this part.

(d) *Additional elements of fugitive emissions monitoring plan.* Each fugitive emissions monitoring plan must include the elements specified in paragraphs (d)(1) and (2) of this section, at a minimum, as applicable.

(1) If you are using OGI, your plan must include procedures to ensure that all fugitive emissions components, except buried yard piping and associated components (e.g., connectors), are monitored during each survey. Example procedures include, but are not limited to, a sitemap with an observation path, a written narrative of where the fugitive emissions components are located and how they will be monitored, or an inventory of fugitive emissions components.

(2) If you are using Method 21 of appendix A-7 to this part, your plan must include a list of fugitive emissions components to be monitored and method for determining the location of fugitive emissions components to be monitored in the field (e.g., tagging, identification on a process and instrumentation diagram, etc.). Your fugitive emissions monitoring plan must include the written plan developed for all of the fugitive emissions components designated as difficult-to-monitor in accordance with paragraph (g)(2) of this section, and the written plan for fugitive emissions components designated as unsafe-to-monitor in accordance with paragraph (g)(3) of this section.

(e) *Monitoring of fugitive emissions components.* Each fugitive emissions component, except buried yard piping and associated components (e.g., connectors), shall be observed or monitored for fugitive emissions during each monitoring survey.

(f) *Initial monitoring survey.* You must conduct initial monitoring surveys according to the requirements specified in paragraphs (f)(1) through (3) of this section.

(1) At single wellhead only sites and small sites, you must conduct an initial monitoring survey using audible, visual, and olfactory (AVO), or any other detection methods (e.g., OGI), within 90 days of the startup of production, for each fugitive emissions components designated facility or by 90 days after the state plan submittal deadline (as specified in § 60.5362c(c)), whichever date is later.

(2) For multi-wellhead only well sites, well sites or centralized production facilities that contain the major production and processing equipment specified in paragraphs (g)(1)(iv)(A), (B), (C), or (D) of this section, and compressor station sites, you must conduct an initial monitoring survey using OGI or Method 21 to appendix A-7 to this part within 90 days of the effective date of your state or Tribal plan, for each fugitive emissions components designated facility, or by 36 months after the state plan submittal deadline (as specified in § 60.5362c(c)), whichever date is later.

(3) Notwithstanding the deadlines, specified in paragraphs (f)(1) through (3) of this section for each fugitive emissions components designated facility located on the Alaskan North Slope, that would be subject to monitoring between September and March, you must conduct an initial monitoring survey within 6 months, or by the following June 30, whichever date is latest.

(g) *Monitoring frequency.* A monitoring survey of each fugitive emissions components designated facility must be performed as specified in paragraph (g)(1) of this section, with the exceptions noted in paragraphs (g)(2) through (4) of this section. Monitoring for fugitive emissions components designated facilities located at well sites and centralized production facilities that have wells located onsite must continue at the specified frequencies in paragraphs (g)(1)(i), (ii), (iii), (iv) and (vi) of this section until the well closure requirements of paragraph (l) of this section are completed.

(1) A monitoring survey of the fugitive emissions components designated facilities must be conducted using the methods and at the frequencies specified in paragraphs (g)(1)(i) through (vi) of this section.

(i) A monitoring survey of the fugitive emissions component designated facilities located at single wellhead only well sites must be conducted at least quarterly using AVO, or any other detection method after the initial survey, except as specified in paragraph (g)(1)(vi) of this section. Any indications of fugitive emissions using these methods are considered fugitive emissions that must be repaired in accordance with paragraph (h) of this section.

(ii) A monitoring survey of the fugitive emissions component designated facilities located at small well sites must be conducted at least quarterly using AVO, or any other detection method, after the initial survey except as specified in paragraph

(g)(1)(vi) of this section. Any indications of fugitive emissions using these methods are considered fugitive emissions that must be repaired in accordance with paragraph (h) of this section. At small well sites with an uncontrolled storage vessel, a visual inspection of all thief hatches and other openings on the storage vessel that are fugitive emissions components must be conducted in conjunction with the monitoring survey to ensure that they are kept closed and sealed at all times except during times of adding or removing material, inspecting or sampling material, or during required maintenance operations. If evidence of a deviation from this requirement is found, you must take corrective action. At small well sites with a separator, a visual inspection of all separator dump valves to ensure the dump valve is free of debris and not stuck in an open position must be conducted in conjunction with the monitoring survey. Any dump valve not operating as designed must be repaired.

(iii) A monitoring survey of the fugitive emissions components designated facilities located at multi-wellhead only well sites must be conducted in accordance with paragraphs (g)(1)(iii)(A) and (B) of this section, except as specified in paragraph (g)(1)(vi) of this section.

(A) A monitoring survey must be conducted at least quarterly using AVO, or any other detection method after the initial survey. Any indications of fugitive emissions using these methods are considered fugitive emissions that must be repaired in accordance with paragraph (h) of this section.

(B) A monitoring survey must be conducted at least semiannually using OGI or Method 21 of appendix A-7 to this part after the initial survey. Consecutive semiannual surveys must be conducted at least 4 months apart and no more than 7 months apart.

(iv) A monitoring survey of the fugitive emissions components designated facilities located at well sites or centralized production facilities that contain the major production and processing equipment specified in paragraphs (g)(1)(iv)(A), (B), (C), or (D) of this section must be conducted at the frequencies in paragraphs (g)(1)(iv)(E) and (F) of this section, except as specified in paragraph (g)(1)(vi) of this section.

(A) One or more controlled storage vessels or tank batteries.

(B) One or more control devices.

(C) One or more natural gas-driven process controllers or pumps.

(D) Two or more pieces of major production and processing equipment

not specified in paragraphs (g)(1)(iv)(A) through (C) of this section.

(E) A monitoring survey must be conducted at least bimonthly using AVO, or any other detection method after the initial survey. Any indications of fugitive emissions using these methods are considered fugitive emissions that must be repaired in accordance with paragraph (h) of this section. A visual inspection of all thief hatches and other openings on storage vessels (or tank batteries) that are fugitive emissions components must be conducted in conjunction with the monitoring survey to ensure that they are kept closed and sealed at all times except during times of adding or removing material, inspecting or sampling material, or during required maintenance operations. If evidence of a deviation from this requirement is found, you must take corrective action. A visual inspection must be conducted of all separator dump valves to ensure the dump valve is free of debris and not stuck in an open position must be conducted in conjunction with the monitoring survey. Any dump valve not operating as designed must be repaired.

(F) A monitoring survey must be conducted at least quarterly using OGI or Method 21 of appendix A-7 to this part after the initial survey. Consecutive quarterly monitoring surveys must be conducted at least 60 calendar days apart.

(v) A monitoring survey of the fugitive emissions components designated facility located at a compressor station must be conducted at the frequencies in paragraphs (g)(1)(v)(A) and (B) of this section, except as specified in paragraph (g)(1)(vi) of this section.

(A) A monitoring survey must be conducted at least monthly using AVO, or any other detection method after the initial survey. Any indications of fugitive emissions using these methods are considered fugitive emissions that must be repaired in accordance with paragraph (h) of this section.

(B) A monitoring survey must be conducted at least quarterly using OGI or Method 21 of appendix A-7 to this part after the initial survey. Consecutive quarterly monitoring surveys must be conducted at least 60 calendar days apart.

(vi) A monitoring survey of the fugitive emissions components designated facility located on the Alaska North Slope must be conducted using OGI of this part or Method 21 to appendix A-7 to this part at least annually. Consecutive annual monitoring surveys must be conducted at least 9 months apart and no more than 13 months apart.

(2) If you are using Method 21 of appendix A-7 to this part, fugitive emissions components that cannot be monitored without elevating the monitoring personnel more than 2 meters above the surface may be designated as difficult-to-monitor. Fugitive emissions components that are designated difficult-to-monitor must meet the specifications of paragraphs (g)(2)(i) through (iv) of this section.

(i) A written plan must be developed for all the fugitive emissions components designated difficult-to-monitor. This written plan must be incorporated into the fugitive emissions monitoring plan required by paragraphs (b), (c), and (d) of this section.

(ii) The plan must include the identification and location of each fugitive emissions component designated as difficult-to-monitor.

(iii) The plan must include an explanation of why each fugitive emissions component designated as difficult-to-monitor is difficult-to-monitor.

(iv) The plan must include a schedule for monitoring the difficult-to-monitor fugitive emissions components at least once per calendar year.

(3) If you are using Method 21 of appendix A-7 to this part, fugitive emissions components that cannot be monitored because monitoring personnel would be exposed to immediate danger while conducting a monitoring survey may be designated as unsafe-to-monitor. Fugitive emissions components that are designated unsafe-to-monitor must meet the specifications of paragraphs (g)(3)(i) through (iv) of this section.

(i) A written plan must be developed for all the fugitive emissions components designated unsafe-to-monitor. This written plan must be incorporated into the fugitive emissions monitoring plan required by paragraphs (b), (c), and (d) of this section.

(ii) The plan must include the identification and location of each fugitive emissions component designated as unsafe-to-monitor.

(iii) The plan must include an explanation of why each fugitive emissions component designated as unsafe-to-monitor is unsafe-to-monitor.

(iv) The plan must include a schedule for monitoring the fugitive emissions components designated as unsafe-to-monitor.

(4) The requirements of paragraphs (g)(1)(iv)(F) and (g)(1)(v)(B) of this section are waived during a quarterly monitoring period for any fugitive emissions components designated facility located within an area that has an average calendar month temperature

below 0 degrees Fahrenheit for two of three consecutive calendar months of a quarterly monitoring period. The calendar month temperature average for each month within the quarterly monitoring period must be determined using historical monthly average temperatures over the previous three years as reported by a National Oceanic and Atmospheric Administration source or other source approved by the Administrator. The requirements of paragraph (g)(1)(iv) and (v) of this section shall not be waived for two consecutive quarterly monitoring periods.

(h) *Repairs.* Each identified source of fugitive emissions shall be repaired in accordance with paragraphs (h)(1) and (2) of this section.

(1) A first attempt at repair shall be made in accordance with paragraphs (h)(1)(i) and (ii) of this section.

(i) A first attempt at repair shall be made no later than 15 calendar days after detection of fugitive emissions that were identified using AVO.

(ii) If you are complying with paragraph (g)(1)(i) through (vi) of this section using OGI or Method 21 of appendix A-7 to this part, a first attempt at repair shall be made no later than 30 calendar days after detection of the fugitive emissions.

(2) Repair shall be completed as soon as practicable, but no later than 15 calendar days after the first attempt at repair as required in paragraph (h)(1)(i) of this section, and 30 calendar days after the first attempt at repair as required in paragraph (h)(1)(ii) of this section.

(3) Delay of repair will be allowed if the conditions in paragraphs (h)(3)(i) or (ii) of this section are met.

(i) If the repair is technically infeasible, would require a vent blowdown, a compressor station shutdown, a well shutdown or well shut-in, or would be unsafe to repair during operation of the unit, the repair must be completed during the next scheduled compressor station shutdown for maintenance, scheduled well shutdown, scheduled well shut-in, after a scheduled vent blowdown, or within 2 years of detecting the fugitive emissions, whichever is earliest. A vent blowdown is the opening of one or more blowdown valves to depressurize major production and processing equipment, other than a storage vessel.

(ii) If the repair requires replacement of a fugitive emissions component or a part thereof, but the replacement cannot be acquired and installed within the repair timelines specified in paragraphs (h)(1) and (2) of this section due to either of the conditions specified in

paragraphs (h)(3)(ii)(A) or (B) of this section, the repair must be completed in accordance with paragraph (h)(3)(ii)(C) of this section and documented in accordance with § 60.5420c(c)(13)(v)(I).

(A) Valve assembly supplies had been sufficiently stocked but are depleted at the time of the required repair.

(B) A replacement fugitive emissions component or a part thereof requires custom fabrication.

(C) The required replacement must be ordered no later than 10 calendar days after the first attempt at repair. The repair must be completed as soon as practicable, but no later than 30 calendar days after receipt of the replacement component, unless the repair requires a compressor station or well shutdown. If the repair requires a compressor station or well shutdown, the repair must be completed in accordance with the timeframe specified in paragraph (h)(3)(i) of this section.

(4) Each identified source of fugitive emissions must be resurveyed to complete repair according to the requirements of paragraphs (h)(4)(i) through (v) of this section, to ensure that there are no fugitive emissions.

(i) The operator may resurvey the fugitive emissions components to verify repair using either Method 21 of appendix A-7 to this part or OGI, except as specified in paragraph (h)(4)(v) of this section.

(ii) For each repair that cannot be made during the monitoring survey when the fugitive emissions are initially found, a digital photograph must be taken of that component, or the component must be tagged during the monitoring survey when the fugitive emissions were initially found for identification purposes and subsequent repair. The digital photograph must include the date that the photograph was taken and must clearly identify the component by location within the site (e.g., the latitude and longitude of the component or by other descriptive landmarks visible in the picture).

(iii) Operators that use Method 21 of appendix A-7 to this part to resurvey the repaired fugitive emissions components are subject to the resurvey provisions specified in paragraphs (h)(4)(iii)(A) and (B) of this section.

(A) A fugitive emissions component is repaired when the Method 21 instrument indicates a concentration of less than 500 ppmv above background or when no soap bubbles are observed when the alternative screening procedures specified in section 8.3.3 of Method 21 of appendix A-7 to this part are used.

(B) Operators must use the Method 21 monitoring requirements specified in

paragraph (c)(8)(ii) of this section or the alternative screening procedures specified in section 8.3.3 of Method 21 of appendix A-7 to this part.

(iv) Operators that use OGI to resurvey the repaired fugitive emissions components are subject to the resurvey provisions specified in paragraphs (h)(4)(iv)(A) and (B) of this section.

(A) A fugitive emissions component is repaired when the OGI instrument shows no indication of visible emissions.

(B) Operators must use the OGI monitoring requirements specified in paragraph (c)(7) of this section.

(v) For fugitive emissions identified using AVO detection methods, the operator may resurvey using those same methods, Method 21 of appendix A-7 to this part, or OGI. For operators that use AVO detection methods, a fugitive emissions component is repaired when there are no indications of fugitive emissions using these methods.

(i) *Initial compliance.* You must demonstrate initial compliance with the standards that apply to fugitive emissions components designated facilities as required by § 60.5410c(i).

(j) *Continuous compliance.* You must demonstrate continuous compliance with the standards that apply to fugitive emissions components designated facilities as required by § 60.5415c(j).

(k) *Reporting and recordkeeping.* You must comply with the reporting requirements as specified in § 60.5420c(b)(1) and (8), and the recordkeeping requirements as specified in § 60.5420c(c)(13).

(l) *Well closure requirements.* You must complete the requirements specified in paragraphs (l)(1) through (4) of this section.

(1) You must submit a well closure plan to the Administrator within 30 days of the cessation of production from all wells located at the well site as specified in § 60.5420c(a)(4)(i). The well closure plan must include, at a minimum, the information specified in paragraphs (l)(1)(i) through (iii) of this section.

(i) Description of the steps necessary to close all wells at the well site, including permanent plugging of all wells;

(ii) Description of the financial requirements and disclosure of financial assurance to complete closure; and

(iii) Description of the schedule for completing all activities in the well closure plan.

(2) You must submit a notification as specified in § 60.5420c(a)(4)(ii) of intent to close the well site to the Administrator 60 days before you begin well closure activities.

(3) You must conduct a survey of the well site using OGI, including each closed well, after completing all well closure activities outlined in the well closure plan specified in paragraph (l)(1) of this section. If any emissions are imaged by the OGI instrument, then you must take steps to eliminate those emissions and you must resurvey the source of emissions. You must repeat steps to eliminate emissions and resurvey the source of emissions until no emissions are imaged by the OGI instrument. You must update the well closure plan specified in paragraph (l)(1) of this section to include the video of the OGI survey demonstrating closure of all wells at the site.

(4) You must maintain the records specified in § 60.5420c(c)(13) and submit the reports specified in § 60.5420c(b)(8).

§ 60.5398c What alternative GHG standards apply to fugitive emissions components designated facilities and what inspection and monitoring requirements apply to covers and closed vent systems when using an alternative technology?

This section provides alternative GHG standards for fugitive emissions components designated facilities in § 60.5397c and alternative continuous inspection and monitoring requirements for covers and closed vent systems in § 60.5416c(a)(1)(ii) and (iii), (2)(ii) through (iv), and (3)(iii) and (iv). If you choose to use an alternative standard under this section, you must submit the notification under paragraph (a) of this section. If you choose to demonstrate compliance with the alternative GHG standards through periodic screening, you are subject to the requirements in paragraph (b) of this section. If you choose to demonstrate compliance through a continuous monitoring system, you are subject to the requirements in paragraph (c) of this section. The technology used for periodic screenings under paragraph (b) of this section or continuous monitoring under paragraph (c) of this section must be approved in accordance with § 60.5398b(d).

(a) *Notification.* If you choose to demonstrate compliance with the alternative GHG standards in either paragraph (b) or (c) of this section, you must notify the Administrator of adoption of the alternative standards in the first annual report following implementation of the alternative standards, as specified in § 60.5424c(a). Once you have implemented the alternative standards, you must continue to comply with the alternative standards.

(b) *Periodic Screening.* You may choose to demonstrate compliance for your fugitive emissions components designated facility and compliance with continuous inspection and monitoring requirements for your covers and closed vent systems through periodic screenings using any methane measurement technology approved in accordance with § 60.5398b(d). If you choose to demonstrate compliance using periodic screenings, you must comply with the requirements in paragraphs (b)(1) through (5) of this section and comply with the recordkeeping and reporting requirements in § 60.5424c.

(1) You must use one or more alternative test method(s) approved per § 60.5398b(d) to conduct periodic screenings.

(i) The required frequencies for conducting periodic screenings are listed in tables 2 and 3 to this subpart. You must choose the appropriate frequency for conducting periodic screenings based on the minimum aggregate detection threshold of the method used to conduct the periodic screenings. You must also use tables 2 and 3 to this subpart to determine whether you must conduct an annual fugitive emissions survey using OGI, except as provided in paragraph (b)(1)(ii) of this section.

(ii) Use of table 2 or 3 to this subpart is based on the required frequency for conducting monitoring surveys in § 60.5397c(g)(1)(i) through (v).

(iii) You may replace one or more individual periodic screening events required by table 2 or 3 to this subpart with an OGI survey. The OGI survey must be conducted according to the requirements outlined in § 60.5397c.

(iv) If you use multiple methods to conduct periodic screenings, you must conduct all periodic screenings, regardless of the method used for the individual periodic screening event, at the frequency required for the alternative test method with the highest aggregate detection threshold (e.g., if you use methods with aggregate detection thresholds of 15 kg/hr, your periodic screenings must be conducted monthly). You must also conduct an annual OGI survey if an annual OGI survey is required for the alternative test method with the highest aggregate detection threshold.

(2) You must develop a monitoring plan that covers the collection of fugitive emissions components, covers, and closed vent systems at each site where you will use periodic screenings to demonstrate compliance. You may develop a site-specific monitoring plan, or you may include multiple sites that you own or operate in one plan. At a

minimum, the monitoring plan must contain the information specified in paragraphs (b)(2)(i) through (ix) of this section.

(i) Identification of each site that will be monitored through periodic screening, including latitude and longitude coordinates of the site in decimal degrees to an accuracy and precision of five decimals of a degree using the North American Datum of 1983.

(ii) Identification of the alternative test method(s) approved per § 60.5398b(d) that will be used for periodic screenings and the spatial resolution (i.e., component-level, area-level, or facility-level) of the technology used for each method.

(iii) Identification of and contact information for the entities that will be performing the periodic screenings.

(iv) Required frequency for conducting periodic screenings, based on the criteria outlined in paragraph (b)(1) of this section.

(v) If you are required to conduct an annual OGI survey by paragraph (b)(1)(i) or (iii) of this section or you choose to replace any individual screening event with an OGI survey, your monitoring plan must also include the information required by § 60.5397c(b).

(vi) Procedures for conducting monitoring surveys required by paragraphs (b)(5)(ii)(A), (b)(5)(iii)(A), and (b)(5)(iv)(A) of this section. At a minimum, your monitoring plan must include the information required by § 60.5397c(c)(2), (3), (7), and (8) and § 60.5397c(d), as applicable. The provisions of § 60.5397c(d)(3) do not apply for purposes of conducting monitoring surveys required by paragraphs (b)(5)(ii) through (iv) of this section.

(vii) Procedures and timeframes for identifying and repairing fugitive emissions components, covers, and closed vent systems from which emissions are detected.

(viii) Procedures and timeframes for verifying repairs for fugitive emissions components, covers, and closed vent systems.

(ix) Records that will be kept and the length of time records will be kept.

(3) You must conduct the initial screening of your site according to the timeframes specified in (b)(3)(i) and (ii) of this section.

(i) Within 90 days of the effective date of your state or Tribal plan for each fugitive emissions components designated facility and storage vessel designated facility located at a well site.

(ii) No later than the final date by which the next monitoring survey required by § 60.5397c(g)(1)(i) through

(v) would have been required to be conducted if you were previously complying with the requirements in § 60.5397c and § 60.5416c.

(4) If you are required to conduct an annual OGI survey by paragraph (b)(1)(i) or (iii) of this section, you must conduct OGI surveys according to the schedule in paragraphs (b)(4)(i) through (iv) of this section.

(i) You must conduct the initial OGI survey no later than 12 calendar months after conducting the initial screening survey in paragraph (b)(3) of this section.

(ii) Each subsequent OGI survey must be conducted no later than 12 calendar months after the previous OGI survey was conducted. Each identified source of fugitive emissions during the OGI survey shall be repaired in accordance with § 60.5397c(h).

(iii) If you replace a periodic screening event with an OGI survey or you are required to conduct a monitoring survey in accordance with paragraph (b)(5)(ii)(A) of this section prior to the date that your next OGI survey under paragraph (b)(4)(ii) of this section is due, the OGI survey conducted in lieu of the periodic screening event or the monitoring survey under paragraph (b)(5)(ii)(A) of this section can be used to fulfill the requirements of paragraph (b)(4)(ii) of this section. The next OGI survey is required to be conducted no later than 12 calendar months after the date of the survey conducted under paragraph (b)(1)(iv) or (b)(5)(ii)(A) of this section.

(iv) You cannot use a monitoring survey conducted under paragraph (b)(5)(iii)(A) or (b)(5)(iv)(A) of this section to fulfill the requirements of paragraph (b)(4)(ii) of this section unless the monitoring survey included all fugitive emission components at the site.

(5) You must investigate confirmed detections of emissions from periodic screening events and repair each identified source of emissions in accordance with paragraphs (b)(5)(i) through (vi) of this section.

(i) You must receive the results of the periodic screening no later than 5 calendar days after the screening event occurs.

(ii) If you use an alternative test method with a facility-level spatial resolution to conduct a periodic screening event and the results of the periodic screening event indicate a confirmed detection of emissions from a designated facility, you must take the actions listed in paragraphs (b)(5)(ii)(A) through (C) of this section.

(A) You must conduct a monitoring survey of the entire fugitive emissions

components designated facility following the procedures in your monitoring plan. During the survey, you must observe each fugitive emissions component for fugitive emissions.

(B) You must inspect all covers and closed vent system(s) with OGI or Method 21 of appendix A-7 to this part in accordance with the requirements in § 60.5416c(b)(1) through (4), as applicable.

(C) You must conduct a visual inspection of all covers and closed vent systems to identify if there are any defects, as defined in § 60.5416c(a)(1)(ii), § 60.5416c(a)(2)(iii), or § 60.5416c(a)(3)(i), as applicable.

(iii) If you use an alternative test method with an area-level spatial resolution to conduct a periodic screening event and the results of the periodic screening event indicate a confirmed detection of emissions from a designated facility, you must take the actions listed in paragraphs (b)(5)(iii)(A) and (B) of this section, as applicable.

(A) You must conduct a monitoring survey of all your fugitive emissions components located within a 4-meter radius of the location of the periodic screening's confirmed detection. You must follow the procedures in your monitoring plan when conducting the survey.

(B) If the confirmed detection occurred in the portion of a site that contains a storage vessel or a closed vent system, you must inspect all covers and all closed vent systems that are connected to all storage vessels and closed vent systems that are within a 2-meter radius of the location of the periodic screening's confirmed detection (*i.e.*, you must inspect the whole system that is connected to the portion of the system in the radius of the detected event, not just the portion of the system that falls within the radius of the detected event).

(1) You must inspect the cover(s) and closed vent system(s) with OGI or Method 21 of appendix A-7 to this part in accordance with the requirements in § 60.5416c(b)(1) through (4), as applicable.

(2) You must conduct a visual inspection of the closed vent system(s) and cover(s) to identify if there are any defects, as defined in § 60.5416c(a)(1)(ii), § 60.5416c(a)(2)(iii), or § 60.5416c(a)(3)(i), as applicable.

(iv) If you use an alternative test method with a component-level spatial resolution to conduct a periodic screening event and the results of the periodic screening event indicate a confirmed detection of emissions from a designated facility, you must take the

actions listed in paragraphs (b)(5)(iv)(A) and (B) of this section, as applicable.

(A) You must conduct a monitoring survey of the all the fugitive emissions components located within a 1-meter radius of the location of the periodic screening's confirmed detection. You must follow the procedures in your monitoring plan when conducting the survey.

(B) If the confirmed detection occurred in the portion of a site that contains a storage vessel or a closed vent system, you must inspect all covers and all closed vent systems that are connected to all storage vessels and closed vent systems that are within a 0.5-meter radius of the location of the periodic screening's confirmed detection (*i.e.*, you must inspect the whole system that is connected to the portion of the system in the radius of the detected event, not just the portion of the system that falls within the radius of the detected event).

(1) You must inspect the cover(s) and closed vent system(s) with OGI or Method 21 of appendix A-7 to this part in accordance with the requirements in § 60.5416c(b)(1) through (4), as applicable.

(2) You must conduct a visual inspection of the closed vent system(s) and cover(s) to identify if there are any defects, as defined in § 60.5416c(a)(1)(ii), § 60.5416c(a)(2)(iii), or § 60.5416c(a)(3)(i), as applicable.

(v) You must repair all sources of fugitive emissions in accordance with § 60.5397c(h) and all emissions or defects of covers and closed vent systems in accordance with § 60.5416c(b)(4), except as specified in this paragraph (b)(5)(v). Except as allowed by §§ 60.5397c(h)(3) and 60.5416c(b)(5), all repairs must be completed, including the resurvey verifying the repair, within 30 days of receiving the results of the periodic screening in paragraph (b)(5)(i) of this section.

(vi) If the results of the periodic screening event in paragraph (b)(5)(i) of this section indicate a confirmed detection at a designated facility, and the ground-based monitoring survey and inspections required by paragraphs (b)(5)(ii) through (iv) of this section demonstrate the confirmed detection was caused by a failure of a control device used to demonstrate continuous compliance under this subpart, you must initiate an investigative analysis to determine the underlying primary and other contributing cause(s) of such failure within 24 hours of receiving the results of the monitoring survey and/or inspection. As part of the investigation, you must determine if the control

device is operating in compliance with the applicable requirements of §§ 60.5415c and 60.5417c, and if not, what actions are necessary to bring the control device into compliance with those requirements as soon as possible and prevent future failures of the control device from the same underlying cause(s).

(vii) If the results of the inspections required in paragraphs (b)(5)(ii) through (iv) of this section indicate that there is an emission or defect in your cover or closed vent system, you must perform an investigative analysis to determine the underlying primary and other contributing cause(s) of emissions from your cover or closed vent system within 5 days of completing the inspection required by paragraphs (b)(5)(ii) through (iv) of this section. The investigative analysis must include a determination as to whether the system was operated outside of the engineering design analysis and whether updates are necessary for the cover or closed vent system to prevent future emissions from the cover and closed vent system.

(6) You must maintain the records as specified in § 60.5420c(c)(3) through (c)(6), (c)(13) and (c)(14), and § 60.5424c(c).

(7) You must submit reports as specified in § 60.5424c.

(c) *Continuous Monitoring.* You may choose to demonstrate compliance for your fugitive emissions components designated facility and compliance with continuous inspection and monitoring requirements for your covers and closed vent systems through continuous monitoring using a technology approved in accordance with § 60.5398b(d). If you choose to demonstrate compliance using continuous monitoring, you must comply and develop a monitoring plan consistent with the requirements in paragraphs (c)(1) through (9) of this section and comply with the recordkeeping and reporting requirements in § 60.5424c.

(1) For the purpose of this section, continuous monitoring means the ability of a methane monitoring system to determine and record a valid methane mass emissions rate or equivalent of designated facilities at least once for every 12-hour block.

(i) The detection threshold of the system must be such that it can detect at least 0.40 kg/hr (0.88 lb/hr) of methane.

(ii) The health of the devices used within the continuous monitoring system must be confirmed for power and function at least twice every six-hour block.

(iii) The continuous monitoring system must transmit all applicable

valid data at least once every 24-hours. The continuous monitoring system must transmit all valid data collected, including health checks required in paragraph (c)(1)(ii) of this section.

(iv) The continuous monitoring system must continuously collect data as specified in paragraph (c)(1) of this section, except as specified in paragraphs (c)(1)(iv)(A) through (D) of this section:

(A) The rolling 12-month average operational downtime of the continuous monitoring system must be less than or equal to 10 percent.

(B) Operational downtime of the continuous monitoring system is defined as a period of time for which any monitor fails to collect or transmit data as specified in paragraph (c)(1) of this section or any monitor is out-of-control as specified in paragraph (c)(1)(iv)(C) of this section.

(C) A monitor is out-of-control if it fails ongoing quality assurance checks, as specified in the alternative test method approved under § 60.5398b(d), or if the monitor output is outside of range. The beginning of the out-of-control period is defined as the time of the failure of the quality assurance check. The end of the out-of-control period is defined as the time when either the monitor passes a subsequent quality assurance check, or a new monitor is installed. The out-of-control period for a monitor outside of range starts at the time when the monitor first reads outside of range and ends when the monitor reads within range again.

(D) The downtime for the continuous monitoring system must be calculated each calendar month. Once 12 months of data are available, at the end of each calendar month, you must calculate the 12-month average by averaging that month with the previous 11 calendar months. You must determine the rolling 12-month average by recalculating the 12-month average at the end of each month.

(2) You must develop a monitoring plan that covers the collection of fugitive emissions components, covers, and closed vent systems for each site where continuous monitoring will be used to demonstrate compliance. At a minimum, the monitoring plan must contain the information specified in paragraphs (c)(2)(i) through (xii) of this section.

(i) Identification of each site to be monitored through continuous monitoring, including latitude and longitude coordinates of the site in decimal degrees to an accuracy and precision of at least four decimals of a degree using the North American Datum of 1983.

(ii) Identification of the approved alternative test method(s) approved under § 60.5398b(d) used for the continuous monitoring, including the detection principle; the manufacturer, make, and model; instrument manual, if applicable; and the manufacturer's recommended maintenance schedule.

(iii) If the continuous monitoring system is administered through a third-party provider, contact information where the provider can be reached 24 hours a day.

(iv) Number and location of monitors. If the continuous monitoring system uses open path technology, you must identify the location of any reflectors used. These locations should be identified by latitude and longitude coordinates in decimal degrees to an accuracy and precision of at least five decimals of a degree using the North American Datum of 1983.

(v) Discussion of system calibration requirements, including but not limited to, the calibration procedures and calibration schedule for the detection systems and meteorology systems.

(vi) Identification of critical components and infrastructure (e.g., power, data systems) and procedures for their repairs.

(vii) Procedures for out-of-control periods.

(viii) Procedures for establishing baseline emissions, including the identification of any sources with methane emissions not subject to this subpart. The procedures for establishing the baseline emissions must account for variability in the operation of the site. Operation of the site during the development of the baseline emissions must represent the site's expected annual production or throughput.

(ix) Procedures for determining when a fugitive emissions event is detected by the continuous monitoring technology.

(x) Procedures and timeframes for identifying and repairing fugitive emissions components, covers, and closed vent systems from which emissions are detected.

(xi) Procedures and timeframes for verifying repairs for fugitive emissions components, covers, and closed vent systems.

(xii) Records that will be kept and the length of time records will be kept.

(3) You must install and begin conducting monitoring with your continuous monitoring system according to the timeframes specified in paragraphs (c)(3)(i) and (ii) of this section.

(i) Within 120 days of the effective date of your state or Tribal plan for each fugitive emissions components

designated facility and storage vessel designated facility located at a well site.

(ii) No later than the final date by which the next monitoring survey required by § 60.5397c(g)(1)(i) through (v) would have been required to be conducted if you were previously complying with the requirements in § 60.5397c and § 60.5416c.

(4) You are subject to the following action-levels as specified in paragraphs (c)(4)(i) and (ii) of this section for any designated facilities located at a well site, centralized production facility, or compressor station.

(i) For designated facilities located at a wellhead only well site, the action levels are as follows.

(A) The 90-day rolling average action-level is 1.2 kg/hr (2.6 lbs/hr) of methane over the site-specific baseline emissions.

(B) The 7-day rolling average action level is 15 kg/hr (34 lbs/hr) of methane over site-specific baseline emissions.

(ii) For designated facilities located at well sites with major production and processing equipment (including small well sites), centralized production facilities, and compressor stations, the action levels are as follows.

(A) The 90-day rolling average action-level is 1.6 kg/hr (3.6 lbs/hr) of methane over the site-specific baseline emissions.

(B) The rolling 7-day average action level is 21 kg/hr (46 lbs/hr) of methane over the site-specific baseline emissions.

(5) You must establish site-specific baseline emissions upon initial installation and activation of a continuous monitoring system. You must establish the baseline emissions under the conditions outlined in paragraphs (c)(5)(i) through (iii) of this section. You must determine the baseline emission rates according to paragraphs (c)(5)(iv) and (v) of this section. The baseline must be established initially and any time there is a major change to the processing equipment at a well site (including small well sites), centralized production facility, or compressor station.

(i) Inspect all fugitive emissions components according to the requirements in § 60.5397c and covers and closed vent systems according to the requirements in § 60.5416c. This includes all fugitive emissions components, covers, and closed vent systems, regardless of whether they are regulated by this subpart. Repairs of any fugitive emissions, leaks, or defects found during the inspection must be completed prior to beginning the period in paragraph (c)(5)(iii) of this section.

(ii) Verify control devices (e.g., flares) on all affected sources are operating in compliance with the applicable requirements of §§ 60.5415c and

60.5417c. You must ensure that all control devices are operating in compliance with the applicable regulations prior to beginning the period in paragraph (b)(5)(iii) of this section. Verify that all other methane emission sources (e.g., reciprocating engines) located at the site are operating consistent with any applicable regulations. You must ensure that these sources are operating in compliance with the applicable regulations prior to beginning the period in paragraph (b)(5)(iii) of this section.

(iii) Using the alternative test method approved per § 60.5398b(d), record the site-level emission rate from your continuous monitoring system for 30 operating days. You must minimize any activities that are not normal, day-to-day activities during this 30 operating day period. Document any maintenance activities and the period (including the start date and time and end date and time) such activities occurred during the 30 operating day period.

(iv) Determine the site-specific baseline by calculating the mean emission rate (kg/hr of methane) for the 30 operating day period, less any time periods when maintenance activities were conducted.

(v) The site-specific baseline emission rate must be no more than 10 times the applicable 90-day action-level defined in paragraphs (c)(4)(i) and (c)(4)(ii) of this section.

(6) Calculate the emission rate from your site according to paragraphs (c)(6)(i) through (iii) of this section. Compare the emission rate calculated in this paragraph (c)(6) to the appropriate action levels in paragraph (c)(4) of this section to determine whether you have exceeded an action level.

(i) Each calendar day, calculate the daily average mass emission rate in kg/hr of methane from your continuous monitoring system.

(ii) Once the system has been operating for 7 calendar days, at the end of each calendar day calculate the 7-day average mass emission rate by averaging the mass emission rate from that day with the mass emission rate from the previous 6 calendar days. Subtract the site-specific baseline mass emission rate from the 7-day average mass emission rate when comparing the mass emission rate to the applicable action level. Determine the 7-day rolling average by recalculating the 7-day average each calendar day, less the site-specific baseline.

(iii) Once the system has been operating for 90 calendar days, at the end of each calendar day calculate the 90-day average mass emission rate by averaging the mass emission rate from

that day with the mass emission rate from the previous 89 calendar days. Subtract the site-specific baseline emission rate from the 90-day average mass emission rate when comparing the mass emission rate to the applicable action level. Determine the 90-day rolling average by recalculating the 90-day average each calendar day, less the site-specific baseline.

(7) Within 5 days of determining that either of your action levels in paragraph (c)(4) of this section has been exceeded, you must initiate an investigative analysis to determine the underlying primary and contributing cause(s) of such exceedance and actions to be taken to reduce the mass emission rate below the applicable action level.

(i) You must complete the investigative analysis and take initial steps to bring the mass emission rate below the action level no later than 5 days after determining there is an exceedance of the action level in paragraph (c)(4)(i)(B) or (c)(4)(ii)(B) of this section.

(ii) You must complete the investigative analysis and take initial steps to bring the mass emission rate below the action level no later than 30 days after determining there is an exceedance of the action level in paragraph (c)(4)(i)(A) or (c)(4)(ii)(A) of this section.

(8) You must develop a mass emission rate reduction plan if you meet any of the criteria in paragraphs (c)(8)(i) through (iii) of this section. The plan must describe the action(s) completed to date to reduce the mass emission rate below the action level, additional measures that you propose to employ to reduce methane emissions below the action level, and a schedule for completion of these measures. You must submit the plan to the Administrator within 60 days of initially determining there is an exceedance of an action level in paragraph (c)(4) of this section.

(i) If, upon completion of the initial actions required under paragraph (c)(7) of this section, the average mass emission rate for the following 30-day period is not below the applicable action level in paragraph (c)(4)(i)(A) or (c)(4)(ii)(A) of this section. The beginning of the 30-day period starts on the calendar day following completion of the initial actions in paragraph (c)(7) of this section.

(ii) If, upon completion of the initial actions required under paragraph (c)(6) of this section, the average mass emission rate for the following 24-hour period is not below the applicable action level in paragraph (c)(4)(i)(B) or (c)(4)(ii)(B) of this section. The average mass emission rate will be the mass

emission rate calculated according to paragraph (c)(6)(i) of this section for the calendar day following completion of the initial corrective actions in paragraph (c)(7) of this section.

(iii) All actions needed to reduce the average mass emission rate below the action level require more than 30 days to implement.

(9) You must maintain the records as specified in § 60.5420c(c)(3) through (c)(6), (c)(13) and (c)(14), and § 60.5424c(e). You must submit the reports as specified in § 60.5420c(b)(1), (b)(3) through (9) and § 60.5424c.

§ 60.5400c What GHG standards apply to process unit equipment designated facilities?

This section applies to process unit equipment designated facilities located at an onshore natural gas processing plant. You must comply with the requirements of paragraphs (a) through (l) of this section to reduce methane emissions from equipment leaks, except as provided in § 60.5402c. As an alternative to the standards in this section, you may comply with the requirements in § 60.5401c.

(a) *General standards.* You must comply with the requirements in paragraphs (b) through (d) of this section for each pump in light liquid service, pressure relief device in gas/vapor service, valve in gas/vapor or light liquid service, and connector in gas/vapor or light liquid service, as applicable. You must comply with the requirements in paragraph (e) of this section for each open-ended valve or line. You must comply with the requirements in paragraph (f) of this section for each closed vent system and control device used to comply with equipment leak provisions in this section. You must comply with paragraph (g) of this section for each pump, valve, and connector in heavy liquid service and pressure relief device in light liquid or heavy liquid service. You must make repairs as specified in paragraph (h) of this section. You must demonstrate initial compliance with the standards as specified in paragraph (i) of this section. You must demonstrate continuous compliance with the standards as specified in paragraph (j) of this section. You must perform the reporting as specified in paragraph (k) of this section. You must perform the recordkeeping as required in paragraph (l) of this section.

(1) Each piece of equipment is presumed to have the potential to emit methane unless an owner or operator demonstrates that the piece of equipment does not have the potential to emit methane. For a piece of

equipment to be considered not to have the potential to emit methane, the methane content of a gaseous stream must be below detection limits using Method 18 of appendix A–6 of this part. Alternatively, if the piece of equipment is in wet gas service, you may choose to determine the methane content of the stream is below the detection limit of the methods described in ASTM E168–16(R2023), E169–16(R2022), or E260–96 (all incorporated by reference, see § 60.17).

(2) [Reserved]

(b) *Monitoring surveys.* You must monitor for leaks using OGI in accordance with appendix K to this part, unless otherwise specified in paragraphs (c) or (d) of this section.

(1) Monitoring surveys must be conducted bimonthly.

(2) Any emissions observed using OGI are defined as a leak.

(c) *Additional requirements for pumps in light liquid service.* In addition to the requirements in paragraph (b) of this section, you must conduct weekly visual inspections of all pumps in light liquid service for indications of liquids dripping from the pump seal, except as specified in paragraphs (c)(3) and (4) of this section. If there are indications of liquids dripping from the pump seal, you must follow the procedure specified in either paragraph (c)(1) or (2) of this section.

(1) Monitor the pump within 5 calendar days using the methods specified in § 60.5406c. A leak is detected if any emissions are observed using OGI, or if an instrument reading of 2,000 ppmv or greater is provided using Method 21 of appendix A–7 to this part.

(2) Designate the visual indications of liquids dripping as a leak and repair the leak as specified in paragraph (h) of this section.

(3) If any pump is equipped with a closed vent system capable of capturing and transporting any leakage from the seal or seals to a process, fuel gas system, or a control device that complies with the requirements of paragraph (f) of this section, it is exempt from the weekly inspection requirements in paragraph (c) of this section.

(4) Any pump that is located within the boundary of an unmanned plant site is exempt from the weekly visual inspection requirements in paragraph (c) of this section, provided that each pump is visually inspected as often as practicable and at least bimonthly.

(d) *Additional requirements for pressure relief devices in gas/vapor service.* In addition to the requirements in paragraph (b) of this section, you

must monitor each pressure relief device as specified in paragraphs (d)(1) of this section, except as specified in paragraphs (d)(2) and (d)(3) of this section.

(1) You must monitor each pressure relief device within 5 calendar days after each pressure release to detect leaks using the methods specified in § 60.5406c. A leak is detected if any emissions are observed using OGI, or if an instrument reading of 500 ppmv or greater is provided using Method 21 of appendix A–7 to this part.

(2) Any pressure relief device that is located in a nonfractionating plant that is monitored only by non-plant personnel may be monitored after a pressure release the next time the monitoring personnel are onsite or within 30 calendar days after a pressure release, whichever is sooner, instead of within 5 calendar days as specified in paragraph (d)(1) of this section. No pressure relief device described in this paragraph may be allowed to operate for more than 30 calendar days after a pressure release without monitoring.

(3) Any pressure relief device that is routed to a process or fuel gas system or equipped with a closed vent system capable of capturing and transporting leakage through the pressure relief device to a control device as described in paragraph (f) of this section is exempt from the requirements of paragraph (d)(1) of this section.

(e) *Open-ended valves or lines.* Each open-ended valve or line must be equipped with a cap, blind flange, plug, or a second valve, except as provided in paragraphs (e)(4) and (5) of this section. The cap, blind flange, plug, or second valve must seal the open end of the valve or line at all times except during operations requiring process fluid flow through the open-ended valve or line.

(1) If evidence of a leak is found at any time by AVO, or any other detection method, a leak is detected.

(2) Each open-ended valve or line equipped with a second valve must be operated in a manner such that the valve on the process fluid end is closed before the second valve is closed.

(3) When a double block-and-bleed system is being used, the bleed valve or line may remain open during operations that require venting the line between the block valves but shall remain closed at all other times.

(4) Open-ended valves or lines in an emergency shutdown system which are designed to open automatically in the event of a process upset are exempt from the requirements of this section.

(5) Open-ended valves or lines containing materials which would autocatalytically polymerize or would

present an explosion, serious overpressure, or other safety hazard if capped or equipped with a double block-and-bleed system as specified in paragraphs (e) introductory text, (e)(2) and (3) of this section are exempt from the requirements of this section.

(f) *Closed vent systems and control devices.* Closed vent systems used to comply with the equipment leak provisions of this section must comply with the requirements in §§ 60.5411c and 60.5416c. Control devices used to comply with the equipment leak provisions of this section must comply with the requirements in §§ 60.5412c, 60.5415c(e), and 60.5417c.

(g) *Pumps, valves, and connectors in heavy liquid service and pressure relief devices in light liquid or heavy liquid service.* If evidence of a potential leak is found at any time by AVO, or any other detection method, a leak is detected and must be repaired in accordance with paragraph (h) of this section.

(h) *Repair requirements.* When a leak is detected, you must comply with the requirements of paragraphs (h)(1) through (5) of this section, except as provided in paragraph (h)(6) of this section.

(1) A weatherproof and readily visible identification tag, marked with the equipment identification number, must be attached to the leaking equipment. The identification tag on equipment may be removed after it has been repaired.

(2) A first attempt at repair must be made as soon as practicable, but no later than 5 calendar days after the leak is detected. A first attempt at repair is not required if the leak is detected using OGI and the equipment identified as leaking would require elevating the repair personnel more than 2 meters above a support surface.

(i) First attempts at repair for pumps in light liquid or heavy liquid service include, but are not limited to, the practices described in paragraphs (h)(2)(i)(A) and (B) of this section, where practicable.

(A) Tightening the packing gland nuts.

(B) Ensuring that the seal flush is operating at design pressure and temperature.

(ii) For each valve where a leak is detected, you must comply with paragraphs (h)(2)(ii)(A) (B), (C) or (D) of this section.

(A) Repack the existing valve with a low-e packing.

(B) Replace the existing valve with a low-e valve; or

(C) Perform a drill and tap repair with a low-e injectable packing.

(D) An owner or operator is not required to utilize a low-e valve or low-e packing to replace or repack a valve if the owner or operator demonstrates that a low-e valve or low-e packing is not technically feasible. Low-e valve or low-e packing that is not suitable for its intended use is considered to be technically infeasible. Factors that may be considered in determining technical infeasibility include: retrofit requirements for installation (e.g., re-piping or space limitation), commercial unavailability for valve type, or certain instrumentation assemblies.

(3) Repair of leaking equipment must be completed within 15 calendar days after detection of each leak, except as provided in paragraphs (h)(4), (5) and (6) of this section.

(4) If the repair for visual indications of liquids dripping for pumps in light liquid service can be made by eliminating visual indications of liquids dripping, you must make the repair within 5 calendar days of detection.

(5) If the repair for AVO or other indication of a leak for open-ended valves or lines; pumps, valves, or connectors in heavy liquid service; or pressure relief devices in light liquid or heavy liquid service can be made by eliminating the AVO, or other indication of a potential leak, you must make the repair within 5 calendar days of detection.

(6) Delay of repair of equipment for which leaks have been detected is allowed if repair within 15 days is technically infeasible without a process unit shutdown or as specified in paragraphs (h)(6)(i) through (v) of this section. Repair of this equipment shall occur before the end of the next process unit shutdown. Monitoring to verify repair must occur within 15 days after startup of the process unit.

(i) Delay of repair of equipment is allowed for equipment which is isolated from the process, and which does not have the potential to emit methane.

(ii) Delay of repair for valves and connectors is allowed if the conditions in paragraphs (h)(6)(ii)(A) and (B) of this section are met.

(A) You must demonstrate that emissions of purged material resulting from immediate repair are greater than the fugitive emissions likely to result from delay of repair, and

(B) When repair procedures are conducted, the purged material is collected and destroyed or recovered in a control device complying with paragraph (f) of this section.

(iii) Delay of repair for pumps is allowed if the conditions in paragraphs (h)(6)(iii)(A) and (B) of this section are met.

(A) Repair requires the use of a dual mechanical seal system that includes a barrier fluid system, and

(B) Repair is completed as soon as practicable, but not later than 6 months after the leak was detected.

(iv) If delay of repair is required to repack or replace the valve, you may use delay of repair. Delay of repair beyond a process unit shutdown is allowed for a valve, if valve assembly replacement is necessary during the process unit shutdown, valve assembly supplies have been depleted, and valve assembly supplies had been sufficiently stocked before the supplies were depleted. Delay of repair beyond the next process unit shutdown will not be allowed unless the next process unit shutdown occurs sooner than 6 months after the first process unit shutdown.

(v) When delay of repair is allowed for a leaking pump, valve, or connector that remains in service, the pump, valve, or connector may be considered to be repaired and no longer subject to delay of repair requirements if two consecutive bimonthly monitoring results show no leak remains.

(i) *Initial compliance.* You must demonstrate initial compliance with the standards that apply to equipment leaks at onshore natural gas processing plants as required by § 60.5410c(g).

(j) *Continuous compliance.* You must demonstrate continuous compliance with the standards that apply to equipment leaks at onshore natural gas processing plants as required by § 60.5415c(i).

(k) *Reporting.* You must perform the reporting requirements as specified in § 60.5420c(b)(1) and (10) and § 60.5422c.

(l) *Recordkeeping.* You must perform the recordkeeping requirements as specified in § 60.5420c(c)(7), (9), and (11) and § 60.5421c.

§ 60.5401c What are the alternative GHG standards for process unit equipment designated facilities?

This section provides alternative standards for process unit equipment designated facilities located at an onshore natural gas processing plant. You may choose to comply with the standards in this section instead of the requirements in § 60.5400c. For purposes of the alternative standards provided in this section, you must comply with the requirements of paragraphs (a) through (m) of this section to reduce methane emissions from equipment leaks, except as provided in § 60.5402c.

(a) *General standards.* You must comply with the requirements in paragraphs (b) of this section for each

pump in light liquid service. You must comply with the requirements of paragraph (c) of this section for each pressure relief device in gas/vapor service. You must comply with the requirements in paragraph (d) of this section for each open-ended valve or line. You must comply with the requirements in paragraph (e) of this section for each closed vent system and control device used to comply with equipment leak provisions in this section. You must comply with paragraph (f) of this section for each valve in gas/vapor or light liquid service. You must comply with paragraph (g) of this section for each pump, valve, and connector in heavy liquid service and pressure relief device in light liquid or heavy liquid service. You must comply with paragraph (h) of this section for each connector in gas/vapor and light liquid service. You must make repairs as specified in paragraph (i) of this section. You must demonstrate initial compliance with the standards as specified in paragraph (j) of this section. You must demonstrate continuous compliance with the standards as specified in paragraph (k) of this section. You must perform the reporting requirements as specified in paragraph (l) of this section. You must perform the recordkeeping requirements as required in paragraph (m) of this section.

(1) Each piece of equipment is presumed to have the potential to emit methane unless an owner or operator demonstrates that the piece of equipment does not have the potential to emit methane. For a piece of equipment to be considered not to have the potential to emit methane, the methane content of a gaseous stream must be below detection limits using Method 18 of appendix A-6 to this part. Alternatively, if the piece of equipment is in wet gas service, you may choose to determine the methane content of the stream is below the detection limit of the methods described in ASTM E168-16(R2023), E169-16(R2022), or E260-96 (all incorporated by reference, see § 60.17).

(2) [Reserved]

(b) *Pumps in light liquid service.* You must monitor each pump in light liquid service monthly to detect leaks by the methods specified in § 60.5406c, except as provided in paragraphs (b)(2) through (4) of this section. A leak is defined as an instrument reading of 2,000 ppmv or greater. A pump that begins operation in light liquid service after the initial startup date for the process unit must be monitored for the first time within 30 days after the end of its startup period, except for a pump that replaces a leaking pump and except as provided in

paragraphs (b)(2) through (4) of this section.

(1) In addition to the requirements in paragraph (b) of this section, you must conduct weekly visual inspections of all pumps in light liquid service for indications of liquids dripping from the pump seal. If there are indications of liquids dripping from the pump seal, you must follow the procedure specified in either paragraph (b)(1)(i) or (ii) of this section.

(i) Monitor the pump within 5 days using the methods specified in § 60.5406c. A leak is defined as an instrument reading of 2,000 ppmv or greater.

(ii) Designate the visual indications of liquids dripping as a leak, and repair the leak as specified in paragraph (i) of this section.

(2) Each pump equipped with a dual mechanical seal system that includes a barrier fluid system is exempt from the requirements in paragraph (b) of this section, provided the requirements specified in paragraphs (b)(2)(i) through (vi) of this section are met.

(i) Each dual mechanical seal system meets the requirements of paragraphs (b)(2)(i)(A), (B), or (C) of this section.

(A) Operated with the barrier fluid at a pressure that is at all times greater than the pump stuffing box pressure; or
(B) Equipped with a barrier fluid degassing reservoir that is routed to a process or fuel gas system or connected by a closed vent system to a control device that complies with the requirements of paragraph (e) of this section; or

(C) Equipped with a system that purges the barrier fluid into a process stream with zero methane emissions to the atmosphere.

(ii) The barrier fluid system is in heavy liquid service or does not have the potential to emit methane.

(iii) Each barrier fluid system is equipped with a sensor that will detect failure of the seal system, the barrier fluid system, or both.

(iv) Each pump is checked according to the requirements in paragraph (b)(1) of this section.

(v) Each sensor meets the requirements in paragraphs (b)(2)(v)(A) through (C) of this section.

(A) Each sensor as described in paragraph (b)(2)(iii) of this section is checked daily or is equipped with an audible alarm.

(B) You determine, based on design considerations and operating experience, a criterion that indicates failure of the seal system, the barrier fluid system, or both.

(C) If the sensor indicates failure of the seal system, the barrier fluid system,

or both, based on the criterion established in paragraph (b)(2)(v)(B) of this section, a leak is detected.

(3) Any pump that is designated, as described in § 60.5421c(b)(12), for no detectable emissions, as indicated by an instrument reading of less than 500 ppmv above background, is exempt from the requirements of paragraphs (b), (b)(1), and (b)(2) of this section if the pump:

(i) Has no externally actuated shaft penetrating the pump housing;

(ii) Is demonstrated to be operating with no detectable emissions as indicated by an instrument reading of less than 500 ppmv above background as measured by the methods specified in § 60.5406c; and

(iii) Is tested for compliance with paragraph (b)(3)(ii) of this section initially upon designation, annually, and at other times requested by the Administrator.

(4) If any pump is equipped with a closed vent system capable of capturing and transporting any leakage from the seal or seals to a process, fuel gas system, or a control device that complies with the requirements of paragraph (e) of this section, it is exempt from paragraphs (b) introductory text and (b)(1) through (3) of this section, and the repair requirements of paragraph (i) of this section.

(5) Any pump that is designated, as described in § 60.5421c(b)(13), as an unsafe-to-monitor pump is exempt from the monitoring and inspection requirements of paragraphs (b) introductory text, (b)(1), and (b)(2)(iv) through (vi) of this section if the conditions in paragraph (b)(5)(i) and (ii) are met.

(i) You demonstrate that the pump is unsafe-to-monitor because monitoring personnel would be exposed to an immediate danger as a consequence of complying with paragraph (b) of this section; and

(ii) You have a written plan that requires monitoring of the pump as frequently as practicable during safe-to-monitor times, but not more frequently than the periodic monitoring schedule otherwise applicable, and you repair the equipment according to the procedures in paragraph (i) of this section if a leak is detected.

(6) Any pump that is located within the boundary of an unmanned plant site is exempt from the weekly visual inspection requirements in paragraph (b)(1) and (b)(2)(iv) of this section, and the daily requirements of paragraph (b)(2)(v) of this section, provided that each pump is visually inspected as often as practicable and at least monthly.

(c) *Pressure relief devices in gas/vapor service.* You must monitor each pressure relief device quarterly using the methods specified in § 60.5406c. A leak is defined as an instrument reading of 500 ppmv or greater above background.

(1) In addition to the requirements in paragraph (c) of this section, after each pressure release, you must monitor each pressure relief device within 5 calendar days after each pressure release to detect leaks. A leak is detected if an instrument reading of 500 ppmv or greater is provided using the methods specified in § 60.5406c(b).

(2) Any pressure relief device that is located in a nonfractionating plant that is monitored only by non-plant personnel may be monitored after a pressure release the next time the monitoring personnel are onsite, or within 30 calendar days after a pressure release, whichever is sooner, instead of within 5 calendar days as specified in paragraph (c)(1) of this section.

(3) No pressure relief device described in paragraph (c)(2) of this section may be allowed to operate for more than 30 calendar days after a pressure release without monitoring.

(4) Any pressure relief device that is routed to a process or fuel gas system or equipped with a closed vent system capable of capturing and transporting leakage through the pressure relief device to a control device as described in paragraph (e) of this section is exempt from the requirements of paragraphs (c) introductory text and (c)(1) of this section.

(5) Pressure relief devices equipped with a rupture disk are exempt from the requirements of paragraphs (c)(1) and (2) of this section provided you install a new rupture disk upstream of the pressure relief device as soon as practicable, but no later than 5 calendar days after each pressure release, except as provided in paragraph (i)(4) of this section.

(d) *Open-ended valves or lines.* Each open-ended valve or line must be equipped with a cap, blind flange, plug, or a second valve, except as provided in paragraphs (d)(4) and (5) of this section. The cap, blind flange, plug, or second valve must seal the open end of the valve or line at all times except during operations requiring process fluid flow through the open-ended valve or line.

(1) If evidence of a leak is found at any time by AVO, or any other detection method, a leak is detected and must be repaired in accordance with paragraph (i) of this section. A leak is defined as an instrument reading of 500 ppmv or greater if Method 21 of appendix A-7 to this part is used.

(2) Each open-ended valve or line equipped with a second valve must be operated in a manner such that the valve on the process fluid end is closed before the second valve is closed.

(3) When a double block-and-bleed system is being used, the bleed valve or line may remain open during operations that require venting the line between the block valves but shall remain closed at all other times.

(4) Open-ended valves or lines in an emergency shutdown system which are designed to open automatically in the event of a process upset are exempt from the requirements of paragraphs (d), and (d)(1) through (3) of this section.

(5) Open-ended valves or lines containing materials which would autocatalytically polymerize or would present an explosion, serious overpressure, or other safety hazard if capped or equipped with a double block-and-bleed system as specified in paragraphs (d) introductory text and (d)(2) and (3) of this section are exempt from the requirements of this section.

(e) *Closed vent systems and control devices.* Closed vent systems used to comply with the equipment leak provisions of this section must comply with the requirements in §§ 60.5411c and 60.5416c. Control devices used to comply with the equipment leak provisions of this section must comply with the requirements in §§ 60.5412c, 60.5415c(e), and 60.5417c.

(f) *Valves in gas/vapor and light liquid service.* You must monitor each valve in gas/vapor and in light liquid service quarterly to detect leaks by the methods specified in § 60.5406c, except as provided in paragraphs (h)(3) through (5) of this section.

(1) A valve that begins operation in gas/vapor service or in light liquid service after the initial startup date for the process unit must be monitored for the first time within 90 days after the end of its startup period to ensure proper installation, except for a valve that replaces a leaking valve and except as provided in paragraphs (h)(3) through (5) of this section.

(2) An instrument reading of 500 ppmv or greater is a leak. You must repair each leaking valve according to the requirements in paragraph (i) of this section.

(3) Any valve that is designated, as described in § 60.5421c(b)(12), for no detectable emissions, as indicated by an instrument reading of less than 500 ppmv above background, is exempt from the requirements of paragraphs (f) of this section if the valve:

(i) Has no externally actuating mechanism in contact with the process fluid;

(ii) Is operated with emissions less than 500 ppmv above background as determined by the methods specified in § 60.5406c; and

(iii) Is tested for compliance with paragraph (f)(3)(ii) of this section initially upon designation, annually, and at other times requested by the Administrator.

(4) Any valve that is designated, as described in § 60.5421c(b)(13), as an unsafe-to-monitor pump is exempt from the monitoring requirements of paragraph (f) of this section if the requirements in paragraphs (f)(4)(i) and (ii) of this section are met.

(i) You demonstrate that the valve is unsafe-to-monitor because monitoring personnel would be exposed to an immediate danger as a consequence of complying with paragraph (f) of this section; and

(ii) You have a written plan that requires monitoring of the valve as frequently as practicable during safe-to-monitor times, but not more frequently than the periodic monitoring schedule otherwise applicable, and you repair the equipment according to the procedures in paragraph (i) of this section if a leak is detected.

(5) Any valve that is designated, as described in § 60.5421c(b)(14), as a difficult-to-monitor valve is exempt from the monitoring requirements of paragraph (h) of this section if the requirements in paragraph (f)(5)(i) through (iii) of this section are met.

(i) You demonstrate that the valve cannot be monitored without elevating the monitoring personnel more than 2 meters above a support surface.

(ii) The process unit within which the valve is located has less than 3.0 percent of its total number of valves designated as difficult-to-monitor.

(iii) You have a written plan that requires monitoring of the at least once per calendar year.

(g) *Pumps, valves, and connectors in heavy liquid service and pressure relief devices in light liquid or heavy liquid service.* If evidence of a potential leak is found at any time by AVO, or any other detection method, you must comply with either paragraph (g)(1) or (2) of this section.

(1) You must monitor the equipment within 5 calendar days by the method specified in § 60.5406c and repair any leaks detected according to paragraph (i) of this section. An instrument reading of 10,000 ppmv or greater is defined as a leak.

(2) You must designate the AVO, or other indication of a leak as a leak and repair the leak according to paragraph (i) of this section.

(h) *Connectors in gas/vapor service and in light liquid service.* You must initially monitor all connectors in the process unit for leaks by the later of either 12 months after the compliance date or 12 months after initial startup. If all connectors in the process unit have been monitored for leaks prior to the compliance date, no initial monitoring is required provided either no process changes have been made since the monitoring or the owner or operator can determine that the results of the monitoring, with or without adjustments, reliably demonstrate compliance despite process changes. If required to monitor because of a process change, you are required to monitor only those connectors involved in the process change.

(1) You must monitor all connectors in gas/vapor service and in light liquid service annually, except as provided in paragraph (e) of this section or paragraph (h)(2) of this section.

(2) Any connector that is designated, as described in § 60.5421c(b)(13), as an unsafe-to-monitor connector is exempt from the requirements of paragraphs (h) and (h)(1) of this section if the requirements of paragraphs (h)(2)(i) and (ii) of this section are met.

(i) You demonstrate the connector is unsafe-to-monitor because monitoring personnel would be exposed to an immediate danger as a consequence of complying with paragraphs (h) and (h)(1) of this section; and

(ii) You have a written plan that requires monitoring of the connector as frequently as practicable during safe-to-monitor times, but not more frequently than the periodic monitoring schedule otherwise applicable, and you repair the equipment according to the procedures in paragraph (i) of this section if a leak is detected.

(3) Inaccessible, ceramic, or ceramic-lined connectors.

(i) Any connector that is inaccessible or that is ceramic or ceramic-lined (*e.g.*, porcelain, glass, or glass-lined), is exempt from the monitoring requirements of paragraphs (h) and (h)(1) of this section, from the leak repair requirements of paragraph (i) of this section, and from the recordkeeping and reporting requirements of §§ 60.5421c and 60.5422c. An inaccessible connector is one that meets any of the specifications in paragraphs (h)(3)(i)(A) through (F) of this section, as applicable.

(A) Buried.

(B) Insulated in a manner that prevents access to the connector by a monitor probe.

(C) Obstructed by equipment or piping that prevents access to the connector by a monitor probe.

(D) Unable to be reached from a wheeled scissor-lift or hydraulic-type scaffold that would allow access to connectors up to 7.6 meters (25 feet) above the ground.

(E) Inaccessible because it would require elevating monitoring personnel more than 2 meters (7 feet) above a permanent support surface or would require the erection of scaffold.

(F) Not able to be accessed at any time in a safe manner to perform monitoring. Unsafe access includes, but is not limited to, the use of a wheeled scissor-lift on unstable or uneven terrain, the use of a motorized man-lift basket in areas where an ignition potential exists, or access would require near proximity to hazards such as electrical lines or would risk damage to equipment.

(ii) If any inaccessible, ceramic, or ceramic-lined connector is observed by AVO, or other means to be leaking, the indications of a leak to the atmosphere by AVO or other means must be eliminated as soon as practicable.

(4) Connectors which are part of an instrumentation systems and inaccessible, ceramic, or ceramic-lined connectors meeting the provisions of paragraph (h)(3) of this section, are not subject to the recordkeeping requirements of § 60.5421c(b)(1).

(i) *Repair requirements.* When a leak is detected, comply with the requirements of paragraphs (i)(1) through (5) of this section, except as provided in paragraph (i)(6) of this section.

(1) A weatherproof and readily visible identification tag, marked with the equipment identification number, must be attached to the leaking equipment. The identification tag on the equipment may be removed after it has been repaired.

(2) A first attempt at repair must be made as soon as practicable, but no later than 5 calendar days after the leak is detected.

(i) First attempts at repair for pumps in light liquid or heavy liquid service include, but are not limited to, the practices described in paragraphs (i)(2)(i)(A) and (B) of this section, where practicable.

(A) Tightening the packing gland nuts.

(B) Ensuring that the seal flush is operating at design pressure and temperature.

(ii) For each valve where a leak is detected, you must comply with paragraphs (i)(2)(ii)(A), (B) or (C), and (D) of this section.

(A) Repack the existing valve with a low-e packing.

(B) Replace the existing valve with a low-e valve; or

(C) Perform a drill and tap repair with a low-e injectable packing.

(D) An owner or operator is not required to utilize a low-e valve or low-e packing to replace or repack a valve if the owner or operator demonstrates that a low-e valve or low-e packing is not technically feasible. Low-e valve or low-e packing that is not suitable for its intended use is considered to be technically infeasible. Factors that may be considered in determining technical infeasibility include: retrofit requirements for installation (*e.g.*, re-piping or space limitation), commercial unavailability for valve type, or certain instrumentation assemblies.

(3) Repair of leaking equipment must be completed within 15 calendar days after detection of each leak, except as provided in paragraphs (i)(4), (5) and (6) of this section.

(4) If the repair for visual indications of liquids dripping for pumps in light liquid service can be made by eliminating visual indications of liquids dripping, you must make the repair within 5 calendar days of detection.

(5) If the repair for AVO or other indication of a leak for open-ended lines or valves; pumps, valves, or connectors in heavy liquid service; or pressure relief devices in light liquid or heavy liquid service can be made by eliminating the AVO, or other indication of a potential leak, you must make the repair within 5 calendar days of detection.

(6) Delay of repair of equipment for which leaks have been detected will be allowed if repair within 15 calendar days is technically infeasible without a process unit shutdown or as specified in paragraphs (i)(6)(i) through (v) of this section. Repair of this equipment shall occur before the end of the next process unit shutdown. Monitoring to verify repair must occur within 15 calendar days after startup of the process unit.

(i) Delay of repair of equipment will be allowed for equipment which is isolated from the process, and which does not have the potential to emit methane.

(ii) Delay of repair for valves and connectors will be allowed if the conditions in paragraphs (i)(6)(ii)(A) and (B) are met.

(A) You demonstrate that emissions of purged material resulting from immediate repair are greater than the fugitive emissions likely to result from delay of repair, and

(B) When repair procedures are conducted, the purged material is

collected and destroyed or recovered in a control device complying with paragraph (e) of this section.

(iii) Delay of repair for pumps will be allowed if the conditions in paragraphs (i)(6)(iii)(A) and (B) of this section are met.

(A) Repair requires the use of a dual mechanical seal system that includes a barrier fluid system, and

(B) Repair is completed as soon as practicable, but not later than 6 months after the leak was detected.

(iv) If delay of repair is required to repack or replace the valve, you may use delay of repair. Delay of repair beyond a process unit shutdown will be allowed for a valve, if valve assembly replacement is necessary during the process unit shutdown, valve assembly supplies have been depleted, and valve assembly supplies had been sufficiently stocked before the supplies were depleted. Delay of repair beyond the next process unit shutdown will not be allowed unless the next process unit shutdown occurs sooner than 6 months after the first process unit shutdown.

(v) When delay of repair is allowed for a leaking pump, valve, or connector that remains in service, the pump, valve, or connector may be considered to be repaired and no longer subject to delay of repair requirements if two consecutive monthly monitoring results show no leak remains.

(j) *Initial compliance.* You must demonstrate initial compliance with the standards that apply to equipment leaks at onshore natural gas processing plants as required by § 60.5410c(g).

(k) *Continuous compliance.* You must demonstrate continuous compliance with the standards that apply to equipment leaks at onshore natural gas processing plants as required by § 60.5415c(i).

(l) *Reporting.* You must perform the reporting requirements as specified in § 60.5420c(b)(1) and (b)(10) and § 60.5422c.

(m) *Recordkeeping.* You must perform the recordkeeping requirements as specified in § 60.5420c(c)(7), (9), (11), and § 60.5421c.

§ 60.5402c What are the exceptions to the GHG standards for process unit equipment designated facilities?

(a) You may comply with the following exceptions to the provisions of §§ 60.5400c(a) and 60.5401c(a), as applicable.

(b) Pumps in light liquid service, pressure relief devices in gas/vapor service, valves in gas/vapor and light liquid service, and connectors in gas/vapor service and in light liquid service that are located at a nonfractionating

plant that does not have the design capacity to process 283,200 standard cubic meters per day (scmd) (10 million standard cubic feet per day) or more of field gas may comply with the exceptions specified in paragraphs (b)(1) or (2) of this section.

(1) You are exempt from bimonthly OGI monitoring as required under § 60.5400c(b).

(2) You are exempt from the routine Method 21 of appendix A–7 to this part monitoring requirements of § 60.5401c(b), (c), (f), and (h), if complying with the alternative standards of § 60.5401c.

(c) Pumps in light liquid service, pressure relief devices in gas/vapor service, valves in gas/vapor and light liquid service, and connectors in gas/vapor service and in light liquid service within a process unit that is located in the Alaskan North Slope are exempt from the monitoring requirements § 60.5400c(b) and (c) and § 60.5401c(b), (c), (f) and (h).

(d) You may use the following provisions instead of § 60.5403c(e):

(1) Equipment is in heavy liquid service if the weight percent evaporated is 10 percent or less at 150 degrees Celsius (302 degrees Fahrenheit) as determined by ASTM D86–96 (incorporated by reference, see § 60.17).

(2) Equipment is in light liquid service if the weight percent evaporated is greater than 10 percent at 150 °Celsius (302 °F) as determined by ASTM D86–96 (incorporated by reference, see § 60.17).

(e) Equipment that is in vacuum service, except connectors in gas/vapor and light liquid service, is excluded from the requirements of § 60.5400c(b) through (g), if it is identified as required in § 60.5421c(b)(15). Equipment that is in vacuum service is excluded from the requirements of § 60.5401c(b) through (g) if it is identified as required in § 60.5421c(b)(15).

(f) Equipment that you designate as having the potential to emit methane less than 300 hr/yr is excluded from the requirements of § 60.5400c(b) through (g) and § 60.5401c(b) through (h), if it is identified as required in § 60.5421c(b)(16) and it meets any of the conditions specified in paragraphs (f)(1) through (3) of this section.

(1) The equipment has the potential to emit methane only during startup and shutdown.

(2) The equipment has the potential to emit methane only during process malfunctions or other emergencies.

(3) The equipment is backup equipment that has the potential to emit methane only when the primary equipment is out of service.

Model Rule—Test Methods and Performance Testing

§ 60.5405c What test methods and procedures must I use for my centrifugal compressor and reciprocating compressor designated facilities?

(a) You must use one of the methods described in paragraph (a)(1) and (2) of this section to screen for emissions or leaks from the reciprocating compressor rod packing when complying with § 60.5393c(a)(2)(iv) and from the compressor dry and wet seal vents when complying with § 60.5392c(a)(2)(i)(A).

(1) *Optical gas imaging instrument.* Use an optical gas imaging instrument for equipment leak detection as specified in either paragraph (a)(1)(i) or (ii) of this section. For the purposes of paragraphs (a)(1)(i) and (ii) of this section, any visible emissions observed by the optical gas imaging instrument from reciprocating rod packing or compressor dry or wet seal vent is a leak.

(i) *Optical gas imaging instrument as specified in appendix K of this part.* For reciprocating compressor and centrifugal compressor designated facilities with wet or dry seals located at onshore natural gas processing plants, use an optical gas imaging instrument to screen for emissions from reciprocating rod packing or centrifugal compressor dry or wet seal vent in accordance with the protocol specified in appendix K of this part.

(ii) *Optical gas imaging instrument as specified in § 60.5397c of this subpart.* For reciprocating compressor and centrifugal compressor designated facilities with wet or dry seals located at centralized production facilities, compressor stations, or other location that is not an onshore natural gas processing plant, use an optical gas imaging instrument to screen for emissions from reciprocating rod packing or centrifugal compressor with wet or dry seals in accordance with the elements of § 60.5397c(c)(7).

(2) *Method 21.* Use Method 21 in appendix A–7 to this part according to § 60.5403c(b)(1) and (2). For the purposes of this section, an instrument reading of 500 ppmv above background or greater is a leak.

(b) You must determine natural gas volumetric flow rate using a rate meter which meets the requirement in Method 2D in appendix A–1 to this part. Rate meters must be calibrated on an annual basis according to the requirements in Method 2D.

(c) You must use a high-volume sampler to measure emissions of the reciprocating compressor rod packing or centrifugal compressor dry or wet seal

vent in accordance with paragraphs (c)(1) through (7) of this section.

(1) You must use a high-volume sampler designed to capture the entirety of the emissions from the applicable vent and measure the entire range of methane concentrations being emitted as well as the total volumetric flow at standard conditions. You must develop a standard operating procedure for this device and document these procedures in the appropriate monitoring plan. In order to get reliable results, persons using this device should be knowledgeable in its operation and the requirements in this section.

(2) This procedure may involve hazardous materials, operations, and equipment. This procedure may not address all of the safety problems associated with its use. It is the responsibility of the user of this procedure to establish appropriate safety and health practices and determine the applicability of regulatory limitations prior to performing this procedure.

(3) The high-volume sampler must include a methane gas sensor(s) which meets the requirements in paragraphs (c)(3)(i) through (iii) of this section.

(i) The methane sensor(s) must be selective to methane with minimal interference, less than 2.5 percent for the sum of responses to other compounds in the gas matrix. You must document the minimal interference through empirical testing or through data provided by the manufacturer of the sensor.

(ii) The methane sensor(s) must have a measurement range over the entire expected range of concentrations.

(iii) The methane sensor(s) must be capable of taking a measurement once every second, and the data system must be capable of recording these results for each sensor at all times during operation of the sampler.

(4) The high-volume sampler must be designed such that it is capable of sampling sufficient volume in order to capture all emissions from the applicable vent. Your high-volume

sampler must include a flow measurement sensor(s) which meets the requirements of paragraphs (c)(4)(i) and (ii) of this section.

(i) The flow measurement sensor must have a measurement range over the entire expected range of flow rates sampled. If needed multiple sensors may be used to capture the entire range of expected flow rates.

(ii) The flow measurement sensor(s) must be capable of taking a measurement once every second, and the data system must be capable of recording these results for each sensor at all times during operation of the sampler.

(5) You must calibrate your methane sensor(s) according to the procedures in paragraphs (c)(5)(i)(A) and (B) of this section, and flow measurement sensors must be calibrated according to the procedures in paragraph (c)(5)(ii) of this section.

(i) For Methane sensor calibration:

(A) Initially and on a semi-annual basis, determine the linearity at four points through the measurement range for each methane sensor using methane gaseous calibration cylinder standards. At each point, the difference between the cylinder value and the sensor reading must be less than 5 percent of the respective calibration gas value. If the sensor does not meet this requirement, perform corrective action on the sensor, and do not use the sampler until these criteria can be met.

(B) Prior to and at the end of each testing day, challenge each sensor at two points, a low point, and a mid-point, using methane gaseous calibration cylinder standards. At each point, the difference between the cylinder value and the sensor reading must be less than 5 percent of the respective calibration gas value. If the sensor does not meet this requirement, perform corrective action on the sensor and do not use the sampler again until these criteria can be met. If the post-test calibration check fails at either point, invalidate the data from all tests performed subsequent to the last passing calibration check.

(ii) Flow measurement sensors must meet the requirements in Method 2D in appendix A-1 to this part. Rate meters must be calibrated on an annual basis according to the requirements in Method 2D. If your flow sensor relies on ancillary temperature and pressure measurements to correct the flow rate to standard conditions, the temperature and pressure sensors must also be calibrated on an annual basis. Standard conditions are defined as 20 °C (68 °F) and 760 mm Hg (29.92 in. Hg).

(6) You must conduct sampling of the reciprocating compressor rod packing or centrifugal compressor dry or wet seal vent in accordance with the procedures in paragraphs (c)(6)(i) through (v) of this section.

(i) The instrument must be operated consistent with manufacturer recommendations; users are encouraged to develop a standard operating procedure to document the exact procedures used for sampling.

(ii) Identify the rod packing or centrifugal compressor dry or wet seal vent to be measured and record the signal to noise ratio (S/N) of the engine. Collect a background methane sample in parts per million by volume (ppmv) for a minimum of one minute and record the result along with the date and time.

(iii) Approach the vent with the sample hose and adjust the sampler so that you are measuring at the full flow rate. Then, adjust the flow rate to ensure the measured methane concentration is within the calibrated range of the methane sensor and minimum methane concentration is at least 2 ppmv higher than the background concentration. Sample for a period of at least one minute and record the average flow rate in standard cubic feet per minute and the methane sample concentration in ppmv, along with the date and time. Standard conditions are defined as 20 °C (68 °F) and 760 mm Hg (29.92 in. Hg).

(iv) Calculate the leak rate according to the following equation:

Equation 1 to paragraph (c)(6)(iv)

$$Q = V \left(\frac{CH4_S - CH4_B}{1000000} \right)$$

Where:

CH4_B = background methane concentration, ppmv

CH4_S = methane sample concentration, ppmv

V = Average flow rate of the sampler, scfm

Q = Methane emission rate, scfm

(v) You must collect at least three separate one-minute measurements and determine the average leak rate. The relative percent difference of these three separate samples should be less than 10 percent.

(7) If the measured natural gas flow determined as specified in paragraph (c)(6) of this section exceeds 70.0 percent of the manufacturer's reported maximum sampling flow rate you must either use a temporary or permanent

flow meter according to paragraph (b) of this section or use another method meeting the requirements in paragraph (d) of this section to determine the leak or flow rate.

(d) As an alternative to a high-volume sampler, you may use any other method that has been validated in accordance with the procedures specified in Method 301 in appendix A to 40 CFR part 63, subject to Administrator approval, as specified in § 60.8(b).

§ 60.5406c What test methods and procedures must I use for my process unit equipment designated facilities?

(a) In conducting the performance tests required in § 60.8, you must use as reference methods and procedures the test methods in appendix A to this part or other methods and procedures as specified in this section, except as provided in § 60.8(b).

(b) You must determine compliance with the standards in § 60.5401c as follows:

(1) Method 21 of appendix A–7 to this part shall be used to determine the presence of leaking sources. The instrument shall be calibrated before use each day of its use by the procedures specified in Method 21 of appendix A–7 to this part. The following calibration gases shall be used:

(i) Zero air (less than 10 ppmv of hydrocarbon in air); and

(ii) A mixture of methane or n-hexane and air at a concentration no more than 2,000 ppmv greater than the leak definition concentration of the equipment monitored. If the monitoring instrument's design allows for multiple calibration scales, then the lower scale shall be calibrated with a calibration gas that is no higher than 2,000 ppmv above the concentration specified as a leak, and the highest scale shall be calibrated with a calibration gas that is approximately or equal to 10,000 ppmv. If only one scale on an instrument will be used during monitoring, you need not calibrate the scales that will not be used during that day's monitoring.

(iii) Verification that your monitoring equipment meets the requirements specified in Section 6.0 of Method 21 of appendix A–7 to this part. For purposes of instrument capability, the leak definition shall be 500 ppmv or greater methane using a FID-based instrument for valves and connectors and 2,000 ppmv methane or greater for pumps. If you wish to use an analyzer other than a FID-based instrument, you must develop a site-specific leak definition that would be equivalent to 500 ppmv methane using a FID-based instrument (e.g., 10.6 eV PID with a specified isobutylene concentration as the leak

definition would provide equivalent response to your compound of interest).

(2) The instrument must be calibrated before use each day of its use by the procedures specified in Method 21 of appendix A–7 to this part. At minimum, you must also conduct precision tests at the interval specified in Method 21 of appendix A–7 to this part, Section 8.1.2, and a calibration drift assessment at the end of each monitoring day. The calibration drift assessment must be conducted as specified in paragraph (b)(2)(i) of this section. Corrective action for drift assessments is specified in paragraphs (b)(2)(ii) and (iii) of this section.

(i) Check the instrument using the same calibration gas that was used to calibrate the instrument before use. Follow the procedures specified in Method 21 of appendix A–7 to this part, Section 10.1, except do not adjust the meter readout to correspond to the calibration gas value. If multiple scales are used, record the instrument reading for each scale used. Divide the arithmetic difference of the initial and post-test calibration response by the corresponding calibration gas value for each scale and multiply by 100 to express the calibration drift as a percentage.

(ii) If a calibration drift assessment shows a negative drift of more than 10 percent, then all equipment with instrument readings between the fugitive emission definition multiplied by (100 minus the percent of negative drift) divided by 100 and the fugitive emission definition that was monitored since the last calibration must be re-monitored.

(iii) If any calibration drift assessment shows a positive drift of more than 10 percent from the initial calibration value, then, at the owner/operator's discretion, all equipment with instrument readings above the fugitive emission definition and below the fugitive emission definition multiplied by (100 plus the percent of positive drift) divided by 100 monitored since the last calibration may be re-monitored.

(c) You shall determine compliance with the no detectable emission standards in § 60.5401c(b), (c), and (f) as specified in paragraphs (c)(1) and (2) of this section.

(1) The requirements of paragraph (b) of this section shall apply.

(2) Method 21 of appendix A–7 to this part shall be used to determine the background level. All potential leak interfaces shall be traversed as close to the interface as possible. The arithmetic difference between the maximum concentration indicated by the instrument and the background level is

compared with 500 ppmv for determining compliance.

(d) You shall demonstrate that a piece of equipment is in light liquid service by showing that all of the following conditions apply:

(1) The vapor pressure of one or more of the organic components is greater than 0.3 kPa at 20 °C (1.2 in. H₂O at 68 °F). Standard reference texts or ASTM D2879–83, –96, or –97 (incorporated by reference, see § 60.17) shall be used to determine the vapor pressures.

(2) The total concentration of the pure organic components having a vapor pressure greater than 0.3 kPa at 20 °C (1.2 in. H₂O at 68 °F) is equal to or greater than 20 percent by weight.

(3) The fluid is a liquid at operating conditions.

(e) Samples used in conjunction with paragraphs (d) and (e) of this section shall be representative of the process fluid that is contained in or contacts the equipment, or the gas being combusted in the flare.

Model Rule—Initial Compliance Requirements

§ 60.5410c How do I demonstrate initial compliance with the standards for each of my designated facilities?

You must determine initial compliance with the standards for each designated facility using the requirements of paragraphs (a) through (i) of this section. Except as otherwise provided in this section, the initial compliance period begins on the date specified in § 60.5387c and ends no later than 1 year after that date. The initial compliance period may be less than 1 full year.

(a) *Gas well liquids unloading standards for well designated facility.* To demonstrate initial compliance with the GHG standards for each gas well liquids unloading operation conducted at your well designated facility as required by § 60.5390c, you must comply with paragraphs (a)(1) through (4) of this section, as applicable.

(1) You must submit the initial annual report for your well designated facility as required in § 60.5420c(b)(1) and (2).

(2) If you comply by using a liquids unloading technology or technique that does not vent to the atmosphere according to § 60.5390c(a)(1), you must maintain the records specified in § 60.5420c(c)(1)(i).

(3) If you comply by using a liquids unloading technology or technique that vents to the atmosphere according to § 60.5390c(a)(2), (b) and (c), you must comply with paragraphs (a)(3)(i) and (ii) of this section.

(i) Employ best management practices to minimize venting of methane emissions as specified in § 60.5390c(d) for each gas well liquids unloading operation.

(ii) Maintain the records specified in § 60.5420c(c)(1)(ii).

(4) If you comply by using § 60.5390c(g), you must comply with paragraphs (b)(4)(i) through (vi) of this section.

(i) Reduce methane emissions by 95.0 percent or greater and as demonstrated by the requirements of § 60.5413c.

(ii) Install a closed vent system that meets the requirements of § 60.5411c(a) and (c) to capture all emissions and route all emissions to a control device that meets the conditions specified in § 60.5412c.

(iii) Conduct an initial performance test as required in § 60.5413c within 180 days after the initial gas well liquids unloading operation or install a control device tested under § 60.5413c(d) which meets the criteria in § 60.5413c(d)(11) and (e), and comply with the continuous compliance requirements of § 60.5415c(e).

(iv) You must conduct the initial inspections required in § 60.5416c(a) and (b).

(v) You must install and operate the continuous parameter monitoring systems in accordance with § 60.5417c(a) through (i), as applicable.

(vi) You must maintain the records specified in § 60.5420c(c)(1)(iii), (c)(7) and (c)(9) through (12), as applicable and submit the reports as required by § 60.5420c(b)(11) through (13), as applicable.

(b) *Associated gas well standards for well designated facility.* To demonstrate initial compliance with the GHG standards for each associated gas well as required by § 60.5391c, you must comply with paragraphs (b)(1) through (5) of this section.

(1) If you comply with the requirements of § 60.5391c(a), you must maintain the records specified in § 60.5420c(c)(2)(i) and submit the information required by § 60.5420c(b)(3)(i) through (iv) in your initial annual report.

(2) If you comply with § 60.5391c(b) because you have demonstrated that annual methane emissions are 40 tons per year or less, you must document the calculation of annual methane emissions determined in accordance with § 60.5391c(e)(1) and submit them in the initial annual report, and comply with paragraphs (b)(4) of this section.

(3) If you comply with § 60.5391c(b) because you have demonstrated that it is not feasible to comply with § 60.5391c(a)(1), (2), (3), or (4) due to

technical reasons, document the initial demonstration and certification of the technical reason in accordance with § 60.5391c(e)(1) and submit them in the initial annual report, and comply with paragraphs (b)(4) of this section. Submit this documentation in the initial annual report, and comply with paragraph (b)(4) of this section.

(4) If you comply with § 60.5391c(b), you must comply with paragraphs (b)(4)(i) through (iv) of this section

(i) Reduce methane emissions by 95.0 percent or greater and as demonstrated by the requirements of § 60.5413c.

(ii) Install a closed vent system that meets the requirements of § 60.5411c(a) and (c) to capture the associated gas and route the captured associated gas to a control device that meets the conditions specified in § 60.5412c.

(iii) Conduct an initial performance test as required in § 60.5413c within 180 days after initial startup or by 36 months after the state plan submittal deadline (as specified in § 60.5362c(c)), whichever date is later, or install a control device tested under § 60.5413c(d) which meets the criteria in § 60.5413c(d)(11) and (e) and you must comply with the continuous compliance requirements of § 60.5415c(e).

(iv) Conduct the initial inspections required in § 60.5416c(a) and (b).

(v) Install and operate the continuous parameter monitoring systems in accordance with § 60.5417c(a) through (g), as applicable.

(vi) Maintain the records specified in § 60.5420c(c)(2)(ii) and (c)(7) and (9) through (12), as applicable.

(5) You must submit the initial annual report for your associated gas well at a well designated facility as required in § 60.5420c(b)(1), (3), and (10) through (12), as applicable.

(c) *Centrifugal compressor designated facility.* To demonstrate initial compliance with the GHG standards in § 60.5392c(a)(1) and (2) for your centrifugal compressors (including both wet seal centrifugal compressors and dry seal centrifugal compressors) that require volumetric flow rate measurements, you must comply with paragraphs (c)(1), (6), and (7) of this section. Alternatively, if you comply with the GHG standards for your wet seal and dry seal centrifugal compressor designated facility by reducing methane emissions from each centrifugal compressor wet seal fluid degassing system by 95.0 percent in accordance with § 60.5392c(a)(3) and (4), you must achieve initial compliance by complying with paragraphs (c)(2) through (7) of this section. If you comply with the GHG standards for

your wet seal and dry seal centrifugal compressor designated facility by routing emissions from the wet seal fluid degassing system through a closed vent system to a process in accordance with § 60.5392c(a)(5), you must achieve initial compliance by complying with paragraphs (c)(2), (4), (6), and (7) of this section.

(1) You must maintain the volumetric flow rates for your centrifugal compressors as specified in paragraphs (c)(1)(i) through (iii) of this section, as applicable. You must conduct your initial annual volumetric measurement as required by § 60.5392c(a)(1).

(i) For your wet seal centrifugal compressors (including self-contained wet seal centrifugal compressors), you must maintain the volumetric flow rate at or below 3 scfm per seal.

(ii) For your Alaska North Slope centrifugal compressor equipped with sour seal oil separator and capture system, you must maintain the volumetric flow rate at or below 9 scfm per seal.

(iii) For your dry seal compressor, you must maintain the volumetric flow rate at or below 10 scfm per seal.

(2) If you use a control device to reduce emissions to comply with § 60.5392c(a)(4) or route the emissions to a process to comply with § 60.5392c(a)(5), you must equip the wet seal fluid degassing system or dry seal system with a cover that meets the requirements of § 60.5411c(b) and route the captured vapors through a closed vent system that meets the requirements of § 60.5411c(a) and (c).

(3) If you use a control device to comply with § 60.5392c(a)(4), you must conduct an initial performance test as required in § 60.5413c within 180 days after initial startup, or by 36 months after the state plan submittal deadline (as specified in § 60.5362c(c)), whichever date is later, or install a control device tested under § 60.5413c(d) which meets the criteria in § 60.5413c(d)(11) and (e) and you must comply with the continuous compliance requirements of § 60.5415c(e).

(4) If you use a control device to comply with § 60.5392c(a)(4) or comply with § 60.5392c(a)(5) by routing to a process, you must conduct the initial inspections required in § 60.5416c(a) and (b).

(5) If you use a control device to comply with § 60.5392c(a)(4), you must install and operate the continuous parameter monitoring systems in accordance with § 60.5417c(a) through (i), as applicable.

(6) You must submit the initial annual report for your centrifugal compressor

designated facility as required in § 60.5420c(b)(1) and (4) and (b)(10) through (12), as applicable.

(7) You must maintain the records as specified in § 60.5420c(c)(3) and (c)(7) through (12), as applicable.

(d) *Reciprocating compressor designated facility.* To demonstrate initial compliance with the GHG standards for each reciprocating compressor designated facility as required by § 60.5393c, you must comply with paragraphs (d)(1) through (7) of this section.

(1) If you comply with § 60.5393c(a) by maintaining volumetric flow rate at or below 2 scfm per cylinder (or a combined cylinder emission flow rate greater than the number of compression cylinders multiplied by 2 scfm) as required by § 60.5393c(a), you must maintain volumetric flow rate at or below 2 scfm and you must conduct your initial annual volumetric flow rate measurement as required by § 60.5393c(a)(1).

(2) If you comply with § 60.5393c by collecting the methane emissions from your reciprocating compressor rod packing using a rod packing emissions collection system as required by § 60.5393c(d)(1), you must equip the reciprocating compressor with a cover that meets the requirements of § 60.5411c(b), route emissions to a process through a closed vent system that meets the requirements of § 60.5411c(a) and (c), and you must conduct the initial inspections required in § 60.5416c(a) and (b).

(3) If you comply with § 60.5393c(d) by collecting emissions from your rod packing emissions collection system by using a control device to reduce methane emissions by 95.0 percent as required by § 60.5393c(d)(2), you must equip the reciprocating compressor with a cover that meets the requirements of § 60.5411c(b), route emissions to a control device that meets the conditions specified in § 60.5412c through a closed vent system that meets the requirements of § 60.5411c(a) and (c), and you must conduct the initial inspections required in § 60.5416c(a) and (b).

(4) If you comply with § 60.5393c(d)(2), you must conduct an initial performance test as required in § 60.5413c within 180 days after initial startup, or by 36 months after the state plan submittal deadline (as specified in § 60.5362c(c)), whichever date is later, or install a control device tested under § 60.5413c(d) which meets the criteria in § 60.5413c(d)(11) and (e) and you must comply with the continuous compliance requirements of § 60.5415c(e).

(5) If you comply with § 60.5393c(d)(2), you must install and operate the continuous parameter monitoring systems in accordance with § 60.5417c(a) through (i), as applicable.

(6) You must submit the initial annual report for your reciprocating compressor as required in § 60.5420c(b)(1), (5) and (10) through (12), as applicable.

(7) You must maintain the records as specified in § 60.5420c(c)(4) and (7) through (12), as applicable.

(e) *Process controller designated facility.* To demonstrate initial compliance with GHG emission standards for your process controller designated facility, you must comply with paragraphs (e)(1) through (5) of this section, as applicable. If you change compliance methods, you must perform the applicable compliance demonstrations of paragraphs (e)(1) through (3) of this section again for the new compliance method, note the change in compliance method in the annual report required by § 60.5420c(b)(6)(iv), and maintain the records required by paragraph (e)(1)(i) or (ii) of this section for the new compliance method.

(1) For process controller designated facilities complying with the requirements of § 60.5394c(a), you must demonstrate that your process controller designated facility does not emit any methane to the atmosphere by meeting the requirements of paragraph (e)(3) of this section.

(i) If you comply by routing the emissions to a process, you must meet the requirements for closed vent systems specified in paragraph (e)(3) of this section.

(ii) If you comply by using a self-contained natural gas-driven process controller, you must conduct an initial no identifiable emissions inspection required by § 60.5416c(b).

(2) For each process controller designated facility located at a site in Alaska that does not have access to electrical power, you must demonstrate initial compliance with § 60.5394c(b)(1) and (2) or with § 60.5394c(b)(3), as an alternative to complying with paragraph § 60.5394c(a) by meeting the requirements specified in (e)(2)(i) through (v) of this section for each process controller, as applicable.

(i) For each process controller in the process controller designated facility operating with a bleed rate of less than or equal to 6 scfh, you must maintain records in accordance with § 60.5420c(c)(5)(iii)(A) that demonstrate the process controller is designed and operated to achieve a bleed rate less than or equal to 6 scfh.

(ii) For each process controller in the process controller designated facility operating with a bleed rate greater than 6 scfh, you must maintain records that demonstrate that a controller with a higher bleed rate than 6 scfh is required based on a specific functional need for that controller as specified in § 60.5420c(c)(5)(iii)(B).

(iii) For each intermittent vent process controller in the process controller designated facility you must demonstrate that each intermittent vent controller does not emit to the atmosphere during idle periods by conducting initial monitoring in accordance with § 60.5394c(b)(2)(ii).

(iv) For each process controller designated facility that complies by reducing methane emissions from all controllers in the process controller designated facility by 95.0 percent in accordance with § 60.5394c(b)(3), you must comply with paragraphs (e)(2)(iv)(A) through (D) of this section.

(A) Reduce methane emissions by 95.0 percent or greater and as demonstrated by the requirements of § 60.5413c.

(B) Route all process controller designated facility emissions to a control device that meets the conditions specified in § 60.5412c through a closed vent system that meets the requirements specified in paragraph (e)(3) of this section.

(C) Conduct an initial performance test as required in § 60.5413c within 180 days after initial startup, or by 36 months after the state plan submittal deadline (as specified in § 60.5362c(c)), whichever date is later, or install a control device tested under § 60.5413c(d) which meets the criteria in § 60.5413c(d)(11) and (e) and you must comply with the continuous compliance requirements of § 60.5415c(g).

(D) Install and operate the continuous parameter monitoring systems in accordance with § 60.5417c(a) through (g), as applicable.

(3) For each closed vent system used to comply with § 60.5394c, you must meet the requirements specified in paragraphs (e)(3)(i) and (ii) of this section.

(i) Install a closed vent system that meets the requirements of § 60.5411c(a) and (c).

(ii) Conduct the initial inspections of the closed vent system and bypasses, if applicable, as required in § 60.5416c(a) and (b).

(4) You must submit the initial annual report for your process controller designated facility as required in § 60.5420c(b)(1) and (6).

(5) You must maintain the records as specified in § 60.5420c(c)(5).

(f) *Pump designated facility.* To demonstrate initial compliance with the GHG standards for your pump designated facility as required by § 60.5395c, you must comply with paragraphs (f)(1) through (4) of this section, as applicable. If you change compliance methods, you must perform the applicable compliance demonstrations of paragraphs (f)(1) and (2) of this section again for the new compliance method, note the change in compliance method in the annual report required by § 60.5420c(b)(9)(v), and maintain the records required by paragraph (f)(4) of this section for the new compliance method.

(1) For pump designated facilities complying with the requirements of § 60.5395c(a) or (b)(2) by routing emissions to a process, you must meet the requirements specified in paragraphs (f)(1)(ii) and (iv) of this section. For pump designated facilities complying with the requirements of § 60.5395c(b)(3), you must meet the requirements specified in paragraphs (f)(1)(i) and (v) of this section.

(i) Reduce methane emissions by 95.0 percent or greater and as demonstrated by the requirements of § 60.5413c.

(ii) Install a closed vent system that meets the requirements of § 60.5411c(a) and (c) to capture all emissions from all pumps in the pump designated facility and route all emissions to a process or control device that meets the conditions specified in § 60.5412c.

(iii) Conduct an initial performance test as required in § 60.5413c within 180 days after initial startup, or by 36 months after the state plan submittal deadline (as specified in § 60.5362c(c)), whichever date is later, or install a control device tested under § 60.5413c(d) which meets the criteria in § 60.5413c(d)(11) and (e), and you must comply with the continuous compliance requirements of § 60.5415c(e).

(iv) Conduct the initial inspections of the closed vent system and bypasses, if applicable, as required in § 60.5416c(a) and (b).

(v) Install and operate the continuous parameter monitoring systems in accordance with § 60.5417c(a) through (i), as applicable.

(2) Submit the certifications specified in paragraphs (f)(2)(i) through (iii) of this section, as applicable.

(i) The certification required by § 60.5395c(b)(3) that there is no vapor recovery unit on site and that there is a control device on site, but it does not achieve a 95.0 percent emissions reduction.

(ii) The certification required by § 60.5395c(b)(4) that there is no control device or process available on site.

(iii) The certification required by § 60.5395c(b)(5)(i) that it is technically infeasible to capture and route the pump designated facility emissions to a process or an existing control device.

(3) You must submit the initial annual report for your pump designated facility as specified in § 60.5420c(b)(1) and (9).

(4) You must maintain the records for your pump designated facility as specified in § 60.5420c (c)(7) and (c)(9) through (12), as applicable, and (c)(14).

(g) *Process unit equipment designated facility.* To achieve initial compliance with the GHG standards for process unit equipment designated facilities as required by § 60.5400c, you must comply with paragraphs (g)(1) through (4) and (g)(11) through (15) of this section, unless you meet and comply with the exception in § 60.5402c(b), (e), or (f) or meet the exemption in § 60.5402c(c). If you comply with the GHG standards for process unit equipment designated facilities using the alternative standards in § 60.5401c, you must comply with paragraphs (g)(5) through (15) of this section, unless you meet the exemption in § 60.5402c(b) or (c) or the exception in § 60.5402c(e) or (f).

(1) You must conduct monitoring for each pump in light liquid service, pressure relief device in gas/vapor service, valve in gas/vapor or light liquid service and connector in gas/vapor or light liquid service as required by § 60.5400c(b).

(2) You must conduct monitoring as required by § 60.5400c(c) for each pump in light liquid service.

(3) You must conduct monitoring as required by § 60.5400c(d) for each pressure relief device in gas/vapor service.

(4) You must comply with the equipment requirements for each open-ended valve or line as required by § 60.5400c(e).

(5) You must conduct monitoring for each pump in light liquid service as required by § 60.5401c(b).

(6) You must conduct monitoring for each pressure relief device in gas/vapor service as required by § 60.5401c(c).

(7) You must comply with the equipment requirements for each open-ended valve or line as required by § 60.5401c(d).

(8) You must conduct monitoring for each valve in gas/vapor or light liquid service as required by § 60.5401c(f).

(9) You must conduct monitoring for each pump, valve, and connector in heavy liquid service and each pressure relief device in light liquid or heavy

liquid service as required by § 60.5401c(g).

(10) You must conduct monitoring for each connector in gas/vapor or light liquid service as required by § 60.5401c(h).

(11) For each pump equipped with a dual mechanical seal system that degasses the barrier fluid reservoir to a process or a control device, each pump which captures and transports leakage from the seal or seals to a process or a control device, or each pressure relief device which captures and transports leakage through the pressure relief device to a process or a control device, you must meet the requirements of paragraph (g)(11)(i) through (vi) of this section.

(i) Reduce methane emissions by 95.0 percent or greater and as demonstrated by the requirements of § 60.5413c or route to a process.

(ii) Install a closed vent system that meets the requirements of § 60.5411c(a) and (c) to capture all emissions from each pump equipped with a dual mechanical seal system that degasses the barrier fluid reservoir, each pump which captures and transports leakage from the seal or seals, or each pressure relief device which captures and transports leakage through the pressure relief device and route all emissions to a process or to a control device that meets the conditions specified in § 60.5412c.

(iii) If routing to a control device, conduct an initial performance test as required in § 60.5413c within 180 days after initial startup, or by 36 months after the state plan submittal deadline (as specified in § 60.5362c(c)), whichever date is later, or install a control device tested under § 60.5413c(d) which meets the criteria in § 60.5413c(d)(11) and (e), and you must comply with the continuous compliance requirements of § 60.5415c(d).

(iv) Conduct the initial inspections of the closed vent system and bypasses, if applicable, as required in § 60.5416c(a) and (b).

(v) Install and operate the continuous parameter monitoring systems in accordance with § 60.5417c(a) through (g), as applicable.

(vi) Maintain the records as required by § 60.5420c(c)(7) and (c)(9) through (12), as applicable and submit the reports as required by § 60.5420c(b)(10) through (12), as applicable.

(12) You must tag and repair each identified leak as required in § 60.5400c(h) or § 60.5400c(i), as applicable.

(13) You must submit the notice required by § 60.5420c(a)(2).

(14) You must submit the initial semiannual report and subsequent semiannual report as required by § 60.5422c and the annual reports in § 60.5420c(b)(10)(i) through (iv), as applicable.

(15) You must maintain the records specified by § 60.5421c.

(h) *Storage vessel designated facility.* To achieve initial compliance with the GHG standards for each storage vessel designated facility as required by § 60.5396c, you must comply with paragraphs (h)(1) through (9) of this section. To achieve initial compliance with the GHG standards for each storage vessel designated facility that complies by using a floating roof in accordance with § 60.5396c(b)(2), you must comply with paragraph (h)(1) and (10) of this section.

(1) You must determine the potential for methane emissions as specified in § 60.5386c(e)(2).

(2) You must reduce methane emissions by 95.0 percent or greater according to § 60.5396c(a) and as demonstrated by the requirements of § 60.5413c or route to a process.

(3) If you use a control device to reduce emissions, you must equip each storage vessel in the storage vessel designated facility with a cover that meets the requirements of § 60.5411c(b), install a closed vent system that meets the requirements of § 60.5411c(a) and (c) to capture all emissions from the storage vessel designated facility, and route all emissions to a control device that meets the conditions specified in § 60.5412c. If you route emissions to a process, you must equip each storage vessel in the storage vessel affected facility with a cover that meets the requirements of § 60.5411c(b), install a closed vent system that meets the requirements of § 60.5411c(a) and (c) to capture all emissions from the storage vessel affected facility, and route all emissions to a process.

(4) If you use a control device to reduce emissions, you must conduct an initial performance test as required in § 60.5413c within 180 days after initial startup, or within 180 days 36 months after the state plan submittal deadline (as specified in § 60.5362c(c)), whichever date is later, or install a control device tested under § 60.5413c(d) which meets the criteria in § 60.5413c(d)(11) and (e), and you must comply with the continuous compliance requirements of § 60.5415c(h).

(5) You must conduct the initial inspections of the closed vent system and bypasses, if applicable, as required in § 60.5416c(a) and (b).

(6) You must install and operate the continuous parameter monitoring systems in accordance with § 60.5417c(a) through (g), as applicable.

(7) You must maintain the records as required by § 60.5420c(c)(7) through (12), as applicable and submit the reports as required by § 60.5420c(b)(10) through (12), as applicable.

(8) You must submit the initial annual report for your storage vessel designated facility required by § 60.5420c(b)(1) and (7).

(9) You must maintain the records required for your storage vessel designated facility, as specified in § 60.5420c(c)(6) for each storage vessel designated facility.

(10) For each storage vessel designated facility that complies by using a floating roof, you must meet the requirements of § 60.112b(a)(1) or (2) and the relevant monitoring, inspection, recordkeeping, and reporting requirements in subpart Kb of this part. You must submit a statement that you are complying with § 60.112b(d)(a)(1) or (2) in accordance with § 60.5396c(b)(2) with the initial annual report specified in § 60.5420c(b)(1) and (7).

(i) *Fugitive emission components designated facility.* To achieve initial compliance with the GHG standards for fugitive emissions components designated facilities as required by § 60.5397c, you must comply with paragraphs (i)(1) through (5) of this section.

(1) You must develop a fugitive emissions monitoring plan as required in § 60.5397c(b), (c), and (d).

(2) You must conduct an initial monitoring survey as required in § 60.5397c(e) and (f).

(3) You must repair each identified source of fugitive emissions for each designated facility as required in § 60.5397c(h).

(4) You must submit the initial annual report for each fugitive emissions components designated facility as required in § 60.5420c(b)(1) and (8).

(5) You must maintain the records specified in § 60.5420c(c)(13).

§ 60.5411c What additional requirements must I meet to determine initial compliance for my covers and closed vent systems?

For each cover or closed vent system at your well, centrifugal compressor, reciprocating compressor, process controller, pump, storage vessel, and process unit equipment designated facilities, you must comply with the applicable requirements of paragraphs (a) through (c) of this section.

(a) *Closed vent system requirements.*

(1) Reciprocating compressor rod packing, process controllers, and

pumps. You must design the closed vent system to capture and route all gases, vapors, and fumes to a process.

(2) Associated gas wells, gas wells where liquids are being unloaded, centrifugal compressors, reciprocating compressor rod packing, process controllers in Alaska, pumps, storage vessels, and process unit equipment. You must design the closed vent system to capture and route all gases, vapors, and fumes to a process or a control device that meets the requirements specified in § 60.5412c(a) through (d) of this section. For pumps complying with § 60.5395c(b)(3), you must design the closed vent system to capture and route all gases, vapors, and fumes to a control device that meets the requirements specified in § 60.5412c(a) through (d) of this section.

(3) You must design and operate the closed vent system with no identifiable emissions as demonstrated by § 60.5416c(a) and (b).

(4) For bypass devices, you must meet the requirements specified in paragraphs (a)(4)(i) and (ii) of this section if the closed vent system contains one or more bypass devices that could be used to divert all or a portion of the gases, vapors, or fumes from entering the control device or being routed to a process.

(i) Except as provided in paragraph (a)(4)(ii) of this section, you must comply with either paragraph (a)(4)(i)(A) or (B) of this section for each bypass device.

(A) You must properly install, calibrate, maintain, and operate a flow indicator at the inlet to the bypass device. The flow indicator must be capable of taking periodic readings as specified in § 60.5416c(a)(4)(i) and sound an alarm, or initiate notification via remote alarm to the nearest field office, when the bypass device is open such that the stream is being, or could be, diverted away from the control device or process, and sent to the atmosphere. You must maintain records of each time the alarm is activated according to § 60.5420c(c)(9).

(B) You must secure the bypass device valve installed at the inlet to the bypass device in the non-diverting position using a car-seal or a lock-and-key type configuration.

(ii) Low leg drains, high point bleeds, analyzer vents, open-ended valves or lines, and safety devices are not subject to the requirements of paragraph (a)(4)(i) of this section.

(b) *Cover requirements for storage vessels, centrifugal compressors, and reciprocating compressors.* (1) The cover and all openings on the cover (e.g., access hatches, sampling ports, pressure

relief devices and gauge wells) shall form a continuous impermeable barrier over the entire surface area of the liquid in the storage vessel or centrifugal compressor wet seal fluid degassing system, or reciprocating compressor rod packing emissions collection system.

(2) Each cover opening shall be secured in a closed, sealed position (e.g., covered by a gasketed lid or cap) whenever material is in the unit on which the cover is installed except during those times when it is necessary to use an opening as follows:

(i) To add material to, or remove material from the unit (this includes openings necessary to equalize or balance the internal pressure of the unit following changes in the level of the material in the unit);

(ii) To inspect or sample the material in the unit;

(iii) To inspect, maintain, repair, or replace equipment located inside the unit; or

(iv) To vent liquids, gases, or fumes from the unit through a closed vent system designed and operated in accordance with the requirements of paragraph (a) of this section to a control device or to a process.

(3) Each storage vessel thief hatch shall be equipped, maintained, and operated with a weighted mechanism or equivalent, to ensure that the lid remains properly seated and sealed under normal operating conditions, including such times when working, standing/breathing, and flash emissions may be generated. You must select gasket material for the hatch based on composition of the fluid in the storage vessel and weather conditions.

(4) You must design and operate the cover with no identifiable emissions as demonstrated by § 60.5416c(a) and (b), except when operated as provided in paragraphs (b)(2)(i) through (iii) of this section.

(c) *Design requirements.* (1) You must conduct an assessment that the closed vent system is of sufficient design and capacity to ensure that all gases, vapors, and fumes from the designated facility are routed to the control device or process and that the control device or process is of sufficient design and capacity to accommodate all emissions from the designated facility. The assessment must be certified by a qualified professional engineer or an in-house engineer with expertise on the design and operation of the closed vent system in accordance with paragraphs (c)(1)(i) and (ii) of this section.

(i) You must provide the following certification, signed and dated by a qualified professional engineer or an in-house engineer: "I certify that the closed

vent system design and capacity assessment was prepared under my direction or supervision. I further certify that the closed vent system design and capacity assessment was conducted, and this report was prepared pursuant to the requirements of subpart OOOOc of this part. Based on my professional knowledge and experience, and inquiry of personnel involved in the assessment, the certification submitted herein is true, accurate, and complete."

(ii) The assessment shall be prepared under the direction or supervision of a qualified professional engineer or an in-house engineer who signs the certification in paragraph (c)(1)(i) of this section.

§ 60.5412c What additional requirements must I meet for determining initial compliance of my control devices?

You must meet the requirements of paragraphs (a) and (b) of this section for each control device used to comply with the emissions standards for your well, centrifugal compressor, reciprocating compressor, storage vessel, process controller, pump, or process unit equipment designated facility. If you use a carbon adsorption system as a control device to meet the requirements of paragraph (a)(2) of this section, you also must meet the requirements in paragraph (c) of this section.

(a) Each control device used to meet the emissions reduction standard in § 60.5390c(g) for your well designated facility gas well that unloads liquids; § 60.5391c(b) for your well designated facility with associated gas; § 60.5392c(a)(4) for your centrifugal compressor designated facility; § 60.5393c(d)(2) for your reciprocating compressor designated facility; § 60.5396c(a)(2) for your storage vessel designated facility; § 60.5394c(b)(3) for your process controller designated facility in Alaska; § 60.5395c(b)(1) for your pumps designated facility; or either § 60.5400c(f) or § 60.5401c(e) for your process equipment designated facility must be installed according to paragraphs (a)(1) through (3) of this section. As an alternative to paragraphs (a)(1) through (3) of this section, you may install a control device model tested under § 60.5413c(d), which meets the criteria in § 60.5413c(d)(11) and which meets the initial and continuous compliance requirements in § 60.5413c(e).

(1) Each enclosed combustion device (e.g., thermal vapor incinerator, catalytic vapor incinerator, boiler, or process heater) must be designed and operated in accordance with paragraph (a)(1)(i) of this section, meet one of the operating limits specified in paragraphs (a)(1)(ii)

through (v) of this section, and except for boilers and process heaters meeting the requirements of paragraph (a)(1)(iii) of this section and catalytic vapor incinerators meeting the requirements of paragraph (a)(1)(v) of this section, meet the operating limits specified in paragraphs (a)(1)(vi) through (ix) of this section. Alternatively, the enclosed combustion device must meet the requirements specified in paragraph (d) of this section.

(i) You must reduce the mass content of methane in the gases vented to the device by 95.0 percent by weight or greater or reduce the concentration of total organic compounds (TOC) in the exhaust gases at the outlet to the device to a level equal to or less than 275 ppmv as propane on a wet basis corrected to 3 percent oxygen as determined in accordance with the requirements of § 60.5413c(b), with the exceptions noted in § 60.5413c(a).

(ii) For an enclosed combustion device for which you demonstrate during the performance test conducted under § 60.5413c(b) that combustion zone temperature is an indicator of destruction efficiency, you must operate at or above the minimum temperature established during the most recent performance test. During the performance test conducted under § 60.5413c(b), you must continuously record the temperature of the combustion zone and average the temperature for each test run. The established minimum temperature limit is the average of the test run averages.

(iii) For an enclosed combustion device which is a boiler or process heater, you must introduce the vent stream into the flame zone of the boiler or process heater and introduce the vent stream with the primary fuel or use the vent stream as the primary fuel.

(iv) For an enclosed combustion device other than those meeting the operating limits in paragraphs (a)(1)(ii), (iii), and (v) of this section, if the enclosed combustion device is unassisted or pressure-assisted, you must maintain the net heating value (NHV) of the gas sent to the enclosed combustion device at or above the applicable limits specified in paragraphs (a)(1)(iv)(A) and (B) of this section. If the enclosed combustion device is steam-assisted or air-assisted, you must meet the applicable limits specified in paragraphs (a)(1)(iv)(C) and (D) of this section, as appropriate.

(A) For enclosed combustion devices that do not use assist gas or pressure-assisted burner tips to promote mixing at the burner tip, 200 British thermal units (Btu) per standard cubic feet (Btu/scf).

(B) For enclosed combustion devices that use pressure-assisted burner tips to promote mixing at the burner tip, 800 Btu/scf.

(C) For steam-assisted and air-assisted enclosed combustion devices, maintain the combustion zone NHV (NHV_{cz}) at or above 270 Btu/scf.

(D) For enclosed combustion devices with perimeter assist air, maintain the NHV dilution parameter (NHV_{dil}) at or above 22 British thermal units per square foot (Btu/sqft). If the only assist air provided to the enclosed combustion control device is perimeter assist air intentionally entrained in lower and/or upper steam at the burner tip and the effective diameter is 9 inches or greater, you are only required to comply with the NHV_{cz} limit specified in paragraph (a)(1)(iv)(C) of this section.

(v) For an enclosed combustion device which is a catalytic vapor incinerator, you must operate the catalytic vapor incinerator at or above the minimum temperature of the catalyst bed inlet and at or above the minimum temperature differential between the catalyst bed inlet and the catalyst bed outlet established in accordance with § 60.5417c(f) and as determined in your performance test conducted in accordance with § 60.5413c(b).

(vi) Unless you have an enclosed combustion device with pressure-assisted burner tips to promote mixing at the burner tip, you must operate each enclosed combustion control device at or below the maximum inlet gas flow rate established in accordance with § 60.5417c(f) and as determined in your performance test conducted in accordance with § 60.5413c(b).

(vii) You must operate the combustion control device at or above the minimum inlet gas flow rate established in accordance with § 60.5417c(f).

(viii) You must install and operate a continuous burning pilot or combustion flame. An alert must be sent to the nearest control room whenever the pilot or combustion flame is unlit.

(ix) You must operate the enclosed combustion device with no visible emissions, except for periods not to exceed a total of 1 minute during any 15-minute period. A visible emissions test using section 11 of Method 22 of appendix A-7 to this part must be performed at least once every calendar month, separated by at least 15 days between each test. The observation period shall be 15 minutes or once the amount of time visible emissions is present has exceeded 1 minute, whichever time period is less. Alternatively, you may conduct visible emissions monitoring according to

§ 60.5417c(h). Devices failing the visible emissions test must follow manufacturer's repair instructions, if available, or best combustion engineering practice as outlined in the unit inspection and maintenance plan, to return the unit to compliant operation. All inspection, repair, and maintenance activities for each unit must be recorded in a maintenance and repair log and must be available for inspection. Following return to operation from maintenance or repair activity, each device must pass a Method 22 of appendix A-7 to this part visual observation as described in this paragraph or be monitored according to § 60.5417c(h).

(2) Each vapor recovery device (e.g., carbon adsorption system or condenser) or other non-destructive control device must be designed and operated to reduce the mass content of methane in the gases vented to the device by 95.0 percent by weight or greater as determined in accordance with the requirements of § 60.5413c(b). As an alternative to the performance testing requirements of § 60.5413c(b), you may demonstrate initial compliance by conducting a design analysis for vapor recovery devices according to the requirements of § 60.5413c(c). For a condenser, you also must calculate the daily average condenser outlet temperature in accordance with § 60.5417c(e), and you must determine the condenser efficiency for the current operating day using the daily average condenser outlet temperature and the condenser performance curve established in accordance with § 60.5417c(f)(2). You must determine the average TOC emission reduction in accordance with § 60.5415c(e)(1)(ix)(D). For a carbon adsorption system, you also must comply with paragraph (c) of this section.

(3) Each flare must be designed and operated according to the requirements specified in paragraphs (a)(3)(i) through (viii) of this section, as applicable. Alternatively, flares must meet the requirements specified in paragraph (d) of this section.

(i) For unassisted flares, you must maintain the NHV of the vent gas sent to the flare at or above 200 Btu/scf.

(ii) For flares that use pressure-assisted burner tips to promote mixing at the burner tip, you must maintain the NHV of the vent gas sent to the flare at or above 800 Btu/scf.

(iii) For steam-assisted and air-assisted flares, you must maintain the NHV_{cz} at or above 270 Btu/scf.

(iv) For flares with perimeter assist air, you must maintain the NHV_{dil} at or above 22 Btu/sqft. If the only assist air

provided to the flare is perimeter assist air intentionally entrained in lower and/or upper steam at the flare tip and the effective diameter is 9 inches or greater, you are not required to comply with the NHV_{dil} limit.

(v) For flares other than pressure-assisted flares, you must determine the maximum flow rate of vent gas to the control system based on the design considerations of the designated facilities to demonstrate compliance with the flare tip velocity limits in § 60.18(b) according to § 60.5417c(d)(8)(iv). The maximum flare tip velocity limits do not apply for pressure-assisted flares.

(vi) You must operate the flare at or above the minimum inlet gas flow rate. The minimum inlet gas flow rate is established based on manufacturer recommendations.

(vii) You must operate the flare with no visible emissions, except for periods not to exceed a total of 1 minute during any 15-minute period. You must conduct the compliance determination with the visible emission limits using Method 22 of appendix A-7 to this part, or you must monitor the flare according to § 60.5417c(h).

(viii) You must install and operate a continuous burning pilot or combustion flame. An alert must be sent to the nearest control room whenever the pilot flame is unlit.

(b) You must operate each control device installed on your well, centrifugal compressor, reciprocating compressor, storage vessel, process controller, pump, or process unit equipment designated facility in accordance with the requirements specified in paragraphs (b)(1) and (2) of this section.

(1) You must operate each control device used to comply with this subpart at all times when gases, vapors, and fumes are vented from the designated facility through the closed vent system to the control device. You may vent more than one designated facility to a control device used to comply with this subpart.

(2) For each control device monitored in accordance with the requirements of § 60.5417c(a) through (i), you must demonstrate compliance according to the requirements of § 60.5415c(e), as applicable.

(c) For each carbon adsorption system used as a control device to meet the requirements of paragraph (a)(2) of this section, you must comply with the requirements of paragraph (c)(1) of this section. If the carbon adsorption system is a regenerative-type carbon adsorption system, you also must comply with the

requirements of paragraph (c)(2) of this section.

(1) You must manage the carbon in accordance with the requirements specified in paragraphs (c)(1)(i) and (ii) of this section.

(i) Following the initial startup of the control device, you must replace all carbon in the carbon adsorption system with fresh carbon on a regular, predetermined time interval that is no longer than the carbon service life established according to § 60.5413c(c)(2) or (3). You must maintain records identifying the schedule for replacement and records of each carbon replacement as required in § 60.5420c(c)(9) and (11).

(ii) You must either regenerate, reactivate, or burn the spent carbon removed from the carbon adsorption system in one of the units specified in paragraphs (c)(1)(ii)(A) through (F) of this section.

(A) Regenerate or reactivate the spent carbon in a unit for which you have been issued a final permit under 40 CFR part 270 that implements the requirements of 40 CFR part 264, subpart X.

(B) Regenerate or reactivate the spent carbon in a unit equipped with an operating organic air emissions control in accordance with an emissions standard for VOC under another subpart in 40 CFR part 63 or this part.

(C) Burn the spent carbon in a hazardous waste incinerator for which the owner or operator complies with the requirements of 40 CFR part 63, subpart EEE, and has submitted a Notification of Compliance under 40 CFR 63.1207(j).

(D) Burn the spent carbon in a hazardous waste boiler or industrial furnace for which the owner or operator complies with the requirements of 40 CFR part 63, subpart EEE, and has submitted a Notification of Compliance under 40 CFR 63.1207(j).

(E) Burn the spent carbon in an industrial furnace for which you have been issued a final permit under 40 CFR part 270 that implements the requirements of 40 CFR part 266, subpart H.

(F) Burn the spent carbon in an industrial furnace that you have designed and operated in accordance with the interim status requirements of 40 CFR part 266, subpart H.

(2) You must comply with the requirements of paragraph (c)(2)(i) through (iii) of this section for each regenerative-type carbon adsorption system.

(i) You must measure and record the average total regeneration stream mass flow or volumetric flow during each carbon bed regeneration cycle to demonstrate compliance with the total

regeneration stream flow established in accordance with § 60.5413c(c)(2).

(ii) You must check the mechanical connections for leakage at least every month, and you must perform a visual inspection at least every 3 months of all components of the flow continuous parameter monitoring system for physical and operational integrity and all electrical connections for oxidation and galvanic corrosion, if your continuous parameter monitoring system is not equipped with a redundant flow sensor.

(iii) You must measure and record the average carbon bed temperature for the duration of the carbon bed steaming cycle and measure the actual carbon bed temperature after regeneration and within 15 minutes of completing the cooling cycle. You must maintain the average carbon bed temperature above the temperature limit in established accordance with § 60.5413c(c)(2) during the carbon bed steaming cycle and below the carbon bed temperature established in accordance with § 60.5413c(c)(2) after the regeneration cycle.

(d) To demonstrate that a flare or enclosed combustion device reduces methane in the gases vented to the device by 95.0 percent by weight or greater, as outlined in § 60.8(b), you may submit a request for an alternative test method. At a minimum, the request must follow the requirements outlined in paragraphs (d)(1) through (5) of this section.

(1) The alternative method must be capable of demonstrating continuous compliance with a combustion efficiency of 95.0 percent or greater or it must be capable of demonstrating continuous compliance with the following metrics:

(i) NHV_{cz} of 270 Btu/scf or greater.

(ii) NHV_{dil} of 22 Btu/sqft or greater, if the alternative test method will be used for enclosed combustion devices or flares with perimeter assist air.

(2) The alternative method must be validated according to Method 301 in appendix A to 40 CFR part 63 for each type of control device covered by the alternative test method (e.g., air-assisted flare, unassisted enclosed combustion device) or the alternative test method must contain performance-based procedures and indicators to ensure self-validation.

(3) At a minimum the alternative test method must provide a reading for each successive 15-minute period.

(4) The alternative test method must be capable of documenting periods when the enclosed combustion device or flare operates with visible emissions. If the alternative test method cannot

identify periods of visible emissions, you must conduct the inspections required by § 60.5417c(d)(8)(v).

(5) If the alternative test method demonstrates compliance with the metrics specified in paragraphs (d)(1)(i) and (ii) of this section instead of demonstrating continuous compliance with 95.0 percent or greater combustion efficiency, you must still install the pilot or combustion flame monitoring system required by § 60.5417c(d)(8)(i). If the alternative test method demonstrates continuous compliance with a combustion efficiency of 95.0 percent or greater, the requirement in § 60.5417c(d)(8)(i) no longer applies.

§ 60.5413c What are the performance testing procedures for control devices?

This section applies to the performance testing of control devices used to demonstrate compliance with the emissions standards for your well, centrifugal compressor, reciprocating compressor, storage vessel, process controller, pump designated facilities complying with § 60.5393c(b)(1), or process unit equipment designated facility. You must demonstrate that a control device achieves the performance requirements of § 60.5412c(a)(1) or (2) using the performance test methods and procedures specified in this section. For condensers and carbon adsorbers, you may use a design analysis as specified in paragraph (c) of this section in lieu of complying with paragraph (b) of this section. In addition, this section contains the requirements for enclosed combustion device performance tests conducted by the manufacturer applicable to well, centrifugal compressor, reciprocating compressor, storage vessel, process controller, pump designated facilities complying with § 60.5393c(b)(1), or process unit equipment designated facilities.

(a) *Performance test exemptions.* You are exempt from the requirements to conduct initial and periodic performance tests and design analyses if you use any of the control devices described in paragraphs (a)(1) through (6) of this section. You are exempt from the requirements to conduct an initial performance test if you use a control device described in paragraph (a)(7) of this section.

(1) A flare that is designed and operated in accordance with the requirements in § 60.5412c(a)(3). You must conduct the compliance determination using Method 22 of appendix A–7 to this part to determine visible emissions or monitor the flare according to § 60.5417c(h). The net heating value of the vent gas must be

determined according to § 60.5417c(d)(8)(ii).

(2) A boiler or process heater with a design heat input capacity of 44 megawatts or greater.

(3) A boiler or process heater into which the vent stream is introduced with the primary fuel or is used as the primary fuel.

(4) A boiler or process heater burning hazardous waste for which you have been issued a final permit under 40 CFR part 270 and comply with the requirements of 40 CFR part 266, subpart H; you have certified compliance with the interim status requirements of 40 CFR part 266, subpart H; you have submitted a Notification of Compliance under 40 CFR 63.1207(j) and comply with the requirements of 40 CFR part 63, subpart EEE; or you comply with 40 CFR part 63, subpart EEE, and will submit a Notification of Compliance under 40 CFR 63.1207(j) by the date specified in § 60.5420c(b)(11) for submitting the initial performance test report.

(5) A hazardous waste incinerator for which you have submitted a Notification of Compliance under 40 CFR 63.1207(j), or for which you will submit a Notification of Compliance under 40 CFR 63.1207(j) by the date specified in § 60.5420c(b)(11) for

submitting the initial performance test report, and you comply with the requirements of 40 CFR part 63, subpart EEE.

(6) A control device for which performance test is waived in accordance with § 60.8(b).

(7) A control device whose model can be demonstrated to meet the performance requirements of § 60.5412c(a)(1)(i) through a performance test conducted by the manufacturer, as specified in paragraph (d) of this section.

(b) *Test methods and procedures.* You must use the test methods and procedures specified in paragraphs (b)(1) through (4) of this section, as applicable, for each performance test conducted to demonstrate that a control device meets the requirements of § 60.5412c(a)(1) or (2). You must conduct the initial and periodic performance tests according to the schedule specified in paragraph (b)(5) of this section. Each performance test must consist of a minimum of 3 test runs. Each run must be at least 1 hour long.

(1) You must use Method 1 or 1A of appendix A–1 to this part, as appropriate, to select the sampling sites. Any references to particulate mentioned in Methods 1 and 1A do not apply to this section.

(i) Sampling sites must be located at the inlet of the first control device and at the outlet of the final control device to determine compliance with a control device percent reduction requirement.

(ii) The sampling site must be located at the outlet of the combustion device to determine compliance with a TOC exhaust gas concentration limit.

(2) You must determine the gas volumetric flow rate using Method 2, 2A, 2C, or 2D of appendix A–2 of this part, as appropriate.

(3) To determine compliance with the control device percent reduction performance requirement in § 60.5412c(a)(1)(i) or (a)(2), you must use Method 18 of appendix A–6 to this part, Method 320 of appendix A to 40 CFR part 63, or ASTM D6348–12e1 (incorporated by reference, see § 60.17) to measure methane or Method 25A of appendix A–7 to this part to measure TOC, as propane. You must use Method 4 of appendix A–3 to this part to convert the Method 25A results to a dry basis. You must use the procedures in paragraphs (b)(3)(i) through (iii) of this section to calculate percent reduction efficiency.

(i) You must compute the mass rate of methane or TOC using the following equations:

Equations 1 and 2 to paragraph (b)(3)(i)

$$E_i = K_2 C_i M_p Q_i$$

$$E_o = K_2 C_o M_p Q_o$$

Where:

E_i , E_o = Mass rate of methane or TOC at the inlet and outlet of the control device, respectively, dry basis, kilograms per hour.

K_2 = Constant, 2.494×10^{-6} (parts per million) (gram-mole per standard cubic meter) (kilogram/gram) (minute/hour), where standard temperature (gram-mole per standard cubic meter) is 20° degrees Celsius.

C_i , C_o = Concentration of methane of the gas stream as measured by Method 18 of appendix A–6, Method 320 of appendix A to 40 CFR part 63, or ASTM D6348–12e1 or TOC, as propane, of the gas stream as measured by Method 25A of appendix A–7 to this part at the inlet and outlet of the control device, respectively, dry basis, parts per million by volume.

M_p = Molecular weight of methane, if using Method 18 of appendix A–6 to this part, Method 320 of appendix A to 40 CFR

part 63, or ASTM D6348–12e1, 16.04 gram/gram-mole. Molecular weight of propane, if using Method 25A of appendix A–7 to this part, 44.1 gram/gram-mole.

Q_i , Q_o = Flow rate of gas stream at the inlet and outlet of the control device, respectively, dry standard cubic meter per minute.

(ii) You must calculate the percent reduction in TOC as follows:

Equation 3 to paragraph (b)(3)(ii)

$$R_{cd} = \frac{E_i - E_o}{E_i} \times 100\%$$

Where:

R_{cd} = Control efficiency of control device, percent.

E_i = Mass rate of methane or TOC at the inlet to the control device as calculated under

paragraph (b)(3)(i) of this section, kilograms per hour.

E_o = Mass rate of methane or TOC at the outlet of the control device, as calculated

under paragraph (b)(3)(i) of this section, kilograms per hour.

(iii) If the vent stream entering a boiler or process heater with a design

capacity less than 44 megawatts is introduced with the combustion air or as a secondary fuel, you must determine the weight-percent reduction of methane across the device by comparing the methane in all combusted vent streams and primary and secondary fuels with the methane exiting the device, respectively.

(4) You must use Method 25A of appendix A-7 to this part to measure

TOC, as propane, to determine compliance with the TOC exhaust gas concentration limit specified in § 60.5412c(a)(1)(i). You must determine the concentration in parts per million by volume on a wet basis and correct it to 3 percent oxygen. You must use the emission rate correction factor for excess air, integrated sampling and analysis procedures of Method 3A or 3B of appendix A-2 to this part, ASTM

D6522-20, or ANSI/ASME PTC 19.10-1981, Part 10 (manual portion only) (both incorporated by reference, see § 60.17) to determine the oxygen concentration. The samples must be taken during the same time that the samples are taken for determining TOC concentration. You must correct the TOC concentration for percent oxygen as follows:

Equation 4 to paragraph (b)(4)

$$C_c = C_m \left(\frac{17.9}{20.9 - \%O_{2m}} \right)$$

Where:

C_c = TOC concentration, as propane, corrected to 3 percent oxygen, parts per million by volume on a wet basis.

C_m = TOC concentration, as propane, parts per million by volume on a wet basis.

$\%O_{2m}$ = Concentration of oxygen, percent by volume as measured, wet.

(5) You must conduct performance tests according to the schedule specified in paragraphs (b)(5)(i) through (iii) of this section.

(i) You must conduct an initial performance test within 180 days after initial startup for your designated facility. You must submit the performance test results as required in § 60.5420c(b)(11).

(ii) You must conduct periodic performance tests for all control devices required to conduct initial performance tests. You must conduct the first periodic performance test no later than 60 months after the initial performance test required in paragraph (b)(5)(i) of this section. You must conduct subsequent periodic performance tests at intervals no longer than 60 months following the previous periodic performance test or whenever you desire to establish a new operating limit. If a control device is not operational at the time a performance test is due, you must conduct the performance test no later than 30 calendar days after returning the control device to service. You must submit the periodic performance test results as specified in § 60.5420c(b)(11).

(iii) If the initial performance test was conducted by the manufacturer under paragraph (d) of this section, you must conduct the first periodic performance test no later than 60 months after initial installation and startup of the control device. You must conduct subsequent periodic performance tests at intervals no longer than 60 months following the previous periodic performance test. If a

control device is not operational at the time a performance test is due, you must conduct the performance test no later than 30 calendar days after returning the control device to service. You must submit the periodic performance test results as specified in § 60.5420c(b)(11).

(c) *Control device design analysis to meet the requirements of § 60.5412c(a)(2).* (1) For a condenser, the design analysis must include an analysis of the vent stream composition, constituent concentrations, flow rate, relative humidity, and temperature and must establish the design outlet organic compound concentration level, design average temperature of the condenser exhaust vent stream and the design average temperatures of the coolant fluid at the condenser inlet and outlet.

(2) For a regenerable carbon adsorption system, the design analysis shall include the vent stream composition, constituent concentrations, flow rate, relative humidity and temperature and shall establish the design exhaust vent stream organic compound concentration level, adsorption cycle time, number and capacity of carbon beds, type and working capacity of activated carbon used for the carbon beds, design total regeneration stream flow over the period of each complete carbon bed regeneration cycle, design carbon bed temperature after regeneration, design carbon bed regeneration time and design service life of the carbon.

(3) For a nonregenerable carbon adsorption system, such as a carbon canister, the design analysis shall include the vent stream composition, constituent concentrations, flow rate, relative humidity and temperature and shall establish the design exhaust vent stream organic compound concentration level, capacity of the carbon bed, type and working capacity of activated

carbon used for the carbon bed and design carbon replacement interval based on the total carbon working capacity of the control device and source operating schedule. In addition, these systems shall incorporate dual carbon canisters in case of emission breakthrough occurring in one canister.

(4) If you and the Administrator do not agree on a demonstration of control device performance using a design analysis, then you must perform a performance test in accordance with the requirements of paragraph (b) of this section to resolve the disagreement. The Administrator may choose to have an authorized representative observe the performance test.

(d) *Performance testing for combustion control devices—manufacturers' performance test.* (1) This paragraph (d) applies to the performance testing of a combustion control device conducted by the device manufacturer. The manufacturer must demonstrate that a specific model of control device achieves the performance requirements in paragraph (d)(11) of this section by conducting a performance test as specified in paragraphs (d)(2) through (10) of this section. You must submit a test report for each combustion control device in accordance with the requirements in paragraph (d)(12) of this section.

(2) Performance testing must consist of three 1-hour (or longer) test runs for each of the four firing rate settings specified in paragraphs (d)(2)(i) through (iv) of this section, making a total of 12 test runs per test. Propene (propylene) gas must be used for the testing fuel. All fuel analyses must be performed by an independent third-party laboratory (not affiliated with the control device manufacturer or fuel supplier).

(i) 90–100 percent of maximum design rate (fixed rate).

(ii) 70–100–70 percent (ramp up, ramp down). Begin the test at 70 percent of the maximum design rate. During the first 5 minutes, incrementally ramp the firing rate to 100 percent of the maximum design rate. Hold at 100 percent for 5 minutes. In the 10 to 15-minute time range, incrementally ramp back down to 70 percent of the maximum design rate. Repeat three more times for a total of 60 minutes of sampling.

(iii) 30–70–30 percent (ramp up, ramp down). Begin the test at 30 percent of the maximum design rate. During the first 5 minutes, incrementally ramp the firing rate to 70 percent of the maximum design rate. Hold at 70 percent for 5 minutes. In the 10 to 15-minute time range, incrementally ramp back down to 30 percent of the maximum design rate. Repeat three more times for a total of 60 minutes of sampling.

(iv) 0–30–0 percent (ramp up, ramp down). Begin the test at the minimum firing rate. During the first 5 minutes, incrementally ramp the firing rate to 30 percent of the maximum design rate. Hold at 30 percent for 5 minutes. In the 10 to 15-minute time range, incrementally ramp back down to the minimum firing rate. Repeat three more times for a total of 60 minutes of sampling.

(3) All models employing multiple enclosures must be tested simultaneously and with all burners operational. Results must be reported for each enclosure individually and for the average of the emissions from all interconnected combustion enclosures/chambers. Control device operating data must be collected continuously throughout the performance test using an electronic Data Acquisition System. A graphic presentation or strip chart of the control device operating data and emissions test data must be included in the test report in accordance with paragraph (d)(12) of this section. Inlet fuel meter data may be manually recorded provided that all inlet fuel data readings are included in the final report.

(4) Inlet testing must be conducted as specified in paragraphs (d)(4)(i) and (ii) of this section.

(i) The inlet gas flow metering system must be located in accordance with Method 2A of appendix A–1 to this part (or other approved procedure) to measure inlet gas flow rate at the control device inlet location. You must position the fitting for filling fuel sample containers a minimum of eight pipe diameters upstream of any inlet gas flow monitoring meter.

(ii) Inlet flow rate must be determined using Method 2A of appendix A–1 to this part. Record the start and stop

reading for each 60-minute THC test. Record the gas pressure and temperature at 5-minute intervals throughout each 60-minute test.

(5) Inlet gas sampling must be conducted as specified in paragraphs (d)(5)(i) and (ii) of this section.

(i) At the inlet gas sampling location, securely connect a fused silica-coated stainless steel evacuated canister fitted with a flow controller sufficient to fill the canister over a 3-hour period. Filling must be conducted as specified in paragraphs (d)(5)(i)(A) through (C) of this section.

(A) Open the canister sampling valve at the beginning of each test run and close the canister at the end of each test run.

(B) Fill one canister across the three test runs such that one composite fuel sample exists for each test condition.

(C) Label the canisters individually and record sample information on a chain of custody form.

(ii) Analyze each inlet gas sample using the methods in paragraphs (d)(5)(ii)(A) through (C) of this section. You must include the results in the test report required by paragraph (d)(12) of this section.

(A) Hydrocarbon compounds containing between one and five atoms of carbon plus benzene using ASTM D1945–03(R2010) (incorporated by reference, see § 60.17).

(B) Hydrogen (H₂), carbon monoxide (CO), carbon dioxide (CO₂), nitrogen (N₂), oxygen (O₂) using ASTM D1945–03(R2010) (incorporated by reference, see § 60.17).

(C) Higher heating value using ASTM D3588–98(R2003) or ASTM D4891–89(R2006) (incorporated by reference, see § 60.17).

(6) Outlet testing must be conducted in accordance with the criteria in paragraphs (d)(6)(i) through (v) of this section.

(i) Sample and flow rate must be measured in accordance with paragraphs (d)(6)(i)(A) and (B) of this section.

(A) The outlet sampling location must be a minimum of four equivalent stack diameters downstream from the highest peak flame or any other flow disturbance, and a minimum of one equivalent stack diameter upstream of the exit or any other flow disturbance. A minimum of two sample ports must be used.

(B) Flow rate must be measured using Method 1 of appendix A–1 to this part for determining flow measurement traverse point location, and Method 2 of appendix A–1 to this part for measuring duct velocity. If low flow conditions are encountered (*i.e.*, velocity pressure

differentials less than 0.05 inches of water) during the performance test, a more sensitive manometer must be used to obtain an accurate flow profile.

(ii) Molecular weight and excess air must be determined as specified in paragraph (d)(7) of this section.

(iii) Carbon monoxide must be determined as specified in paragraph (d)(8) of this section.

(iv) THC must be determined as specified in paragraph (d)(9) of this section.

(v) Visible emissions must be determined as specified in paragraph (d)(10) of this section.

(7) Molecular weight and excess air determination must be performed as specified in paragraphs (d)(7)(i) through (iii) of this section.

(i) An integrated bag sample must be collected during the moisture test required by Method 4 of appendix A–3 to this part following the procedure specified in (d)(7)(i)(A) and (B) of this section. Analyze the bag sample using a gas chromatograph-thermal conductivity detector (GC–TCD) analysis meeting the criteria in paragraphs (d)(7)(i)(C) and (D) of this section.

(A) Collect the integrated sample throughout the entire test and collect representative volumes from each traverse location.

(B) Purge the sampling line with stack gas before opening the valve and beginning to fill the bag. Clearly label each bag and record sample information on a chain of custody form.

(C) The bag contents must be vigorously mixed prior to the gas chromatograph analysis.

(D) The GC–TCD calibration procedure in Method 3C of appendix A–2 to this part must be modified as follows: For the initial calibration, triplicate injections of any single concentration must agree within 5 percent of their mean to be valid. The calibration response factor for a single concentration re-check must be within 10 percent of the original calibration response factor for that concentration. If this criterion is not met, repeat the initial calibration using at least three concentration levels.

(ii) Calculate and report the molecular weight of oxygen, carbon dioxide, methane and nitrogen in the integrated bag sample and include in the test report specified in paragraph (d)(12) of this section. Moisture must be determined using Method 4 of appendix A–3 to this part. Traverse both ports with the sampling train required by Method 4 of appendix A–3 to this part during each test run. Ambient air must not be introduced into the integrated bag sample required by Method 3C of

appendix A–2 to this part during the port change.

(iii) Excess air must be determined using resultant data from the Method 3C tests and Method 3B of appendix A–2 to this part, equation 3B–1, or ANSI/ASME PTC 19.10–1981, Part 10 (manual portion only) (incorporated by reference, see § 60.17).

(8) Carbon monoxide must be determined using Method 10 of appendix A–4 of this part. Run the test simultaneously with Method 25A of appendix A–7 to this part using the same sampling points. An instrument range of 0–10 parts per million by volume-dry (ppmv) is recommended.

(9) Total hydrocarbon determination must be performed as specified by in paragraphs (d)(9)(i) through (vii) of this section.

(i) Conduct THC sampling using Method 25A of appendix A–7 to this part, except that the option for locating the probe in the center 10 percent of the stack is not allowed. The THC probe must be traversed to 16.7 percent, 50 percent, and 83.3 percent of the stack diameter during each test run.

(ii) A valid test must consist of three Method 25A tests, each no less than 60 minutes in duration.

(iii) A 0 to 10 parts per million by volume-wet (ppmv) (as propane)

measurement range is preferred; as an alternative a 0 to 30 ppmv (as propane) measurement range may be used.

(iv) Calibration gases must be propane in air and be certified through EPA–600/R–12/531—“EPA Traceability Protocol for Assay and Certification of Gaseous Calibration Standards,” (incorporated by reference, see § 60.17).

(v) THC measurements must be reported in terms of ppmv as propane.

(vi) THC results must be corrected to 3 percent CO₂, as measured by Method 3C of appendix A–2 to this part. You must use the following equation for this diluent concentration correction:

Equation 5 to paragraph (d)(9)(vi)

$$C_{corr} = C_{meas} \left(\frac{3}{CO_{2meas}} \right)$$

Where:

C_{meas} = The measured concentration of the pollutant.

CO_{2meas} = The measured concentration of the CO₂ diluent.

3 = The corrected reference concentration of CO₂ diluent.

C_{corr} = The corrected concentration of the pollutant.

(vii) Subtraction of methane or ethane from the THC data is not allowed in determining results.

(10) Visible emissions must be determined using Method 22 of appendix A–7 to this part. The test must be performed continuously during each test run. A digital color photograph of the exhaust point, taken from the position of the observer and annotated with date and time, must be taken once per test run and the 12 photos included in the test report specified in paragraph (d)(12) of this section.

(11) For performance test criteria:

(i) The control device model tested must meet the criteria in paragraphs (d)(11)(i)(A) through (D) of this section. These criteria must be reported in the test report required by paragraph (d)(12) of this section.

(A) Results from Method 22 of appendix A–7 to this part determined under paragraph (d)(10) of this section with no indication of visible emissions.

(B) Average results from Method 25A of appendix A–7 to this part determined under paragraph (d)(9) of this section equal to or less than 10.0 ppmv THC as propane corrected to 3.0 percent CO₂.

(C) Average CO emissions determined under paragraph (d)(8) of this section equal to or less than 10 parts ppmv, corrected to 3.0 percent CO₂.

(D) Excess air determined under paragraph (d)(7) of this section equal to or greater than 150 percent.

(ii) The manufacturer must determine a minimum inlet gas flow rate above which each control device model must be operated to achieve the criteria in paragraph (d)(11)(iii) of this section. The manufacturer must determine a maximum inlet gas flow rate which must not be exceeded for each control device model to achieve the criteria in paragraph (d)(11)(iii) of this section. The minimum and maximum inlet gas flow rate must be included in the test report required by paragraph (d)(12) of this section.

(iii) A manufacturer must demonstrate a destruction efficiency of at least 95.0 percent for THC, as propane. A control device model that demonstrates a destruction efficiency of 95.0 percent for THC, as propane, will meet the control requirement for 95.0 percent destruction of methane required under this subpart.

(12) The owner or operator of a combustion control device model tested under this paragraph (d)(12) must submit the information listed in paragraphs (d)(12)(i) through (vi) of this section for each test run in the test report required by this section in accordance with § 60.5420c(b)(12). Owners or operators who claim that any of the performance test information being submitted is confidential business information (CBI) must submit a complete file including information claimed to be CBI to the OAQPS CBI office. The preferred method to receive CBI is for it to be transmitted electronically using email attachments,

File Transfer Protocol, or other online file sharing services. Electronic submissions must be transmitted directly to the OAQPS CBI Office at the email address oaqpscbi@epa.gov and should include clear CBI markings and be flagged to the attention of the Leader, Measurement Policy Group. If assistance is needed with submitting large electronic files that exceed the file size limit for email attachments, and if you do not have your own file sharing service, please email oaqpscbi@epa.gov to request a file transfer link. If you cannot transmit the file electronically, you may send CBI information through the postal service to the following address: U.S. EPA, Attn: OAQPS Document Control Officer and Measurement Policy Group Leader, Mail Drop: C404–02, 109 T.W. Alexander Drive, P.O. Box 12055, RTP, North Carolina 27711. The mailed CBI material should be double wrapped and clearly marked. Any CBI markings should not show through the outer envelope. The same file with the CBI omitted must be submitted to Oil_and_Gas_PT@EPA.GOV.

(i) A full schematic of the control device and dimensions of the device components.

(ii) The maximum net heating value of the device.

(iii) The test fuel gas flow range (in both mass and volume). Include the minimum and maximum allowable inlet gas flow rate.

(iv) The air/stream injection/assist ranges, if used.

(v) The test conditions listed in paragraphs (d)(12)(v)(A) through (O) of

this section, as applicable for the tested model.

(A) Fuel gas delivery pressure and temperature.

(B) Fuel gas moisture range.

(C) Purge gas usage range.

(D) Condensate (liquid fuel)

separation range.

(E) Combustion zone temperature range. This is required for all devices that measure this parameter.

(F) Excess air range.

(G) Flame arrestor(s).

(H) Burner manifold.

(I) Continuous pilot flame indicator.

(J) Pilot flame design fuel and calculated or measured fuel usage.

(K) Tip velocity range.

(L) Momentum flux ratio.

(M) Exit temperature range.

(N) Exit flow rate.

(O) Wind velocity and direction.

(vi) The test report must include all calibration quality assurance/quality control data, calibration gas values, gas cylinder certification, strip charts, or other graphic presentations of the data annotated with test times and calibration values.

(e) *Initial and continuous compliance for combustion control devices tested by the manufacturer in accordance with paragraph (d) of this section.* This paragraph (e) applies to the demonstration of compliance for a combustion control device tested under the provisions in paragraph (d) of this section. Owners or operators must demonstrate that a control device achieves the performance criteria in paragraph (d)(11) of this section by installing a device tested under paragraph (d) of this section, complying with the criteria specified in paragraphs (e)(1) through (10) of this section, maintaining the records specified in § 60.5420c(c)(10) and submitting the report specified in § 60.5420c(b)(10)(v) and (b)(12).

(1) The inlet gas flow rate must be equal to or greater than the minimum inlet gas flow rate and equal to or less than the maximum inlet gas flow rate specified by the manufacturer.

(2) A pilot or combustion flame must be present at all times of operation. An alert must be sent to the nearest control room whenever the pilot or combustion flame is unlit.

(3) Devices must be operated with no visible emissions, except for periods not to exceed a total of 1 minute during any 15-minute period. A visible emissions test conducted according to section 11 of Method 22 of appendix A-7 to this part must be performed at least once every calendar month, separated by at least 15 days between each test. The observation period shall be 15 minutes

or once the amount of time visible emissions is present has exceeded 1 minute, whichever time period is less. Alternatively, you may conduct visible emissions monitoring according to § 60.5417c(h).

(4) Devices failing the visible emissions test must follow manufacturer's repair instructions, if available, or best combustion engineering practice as outlined in the unit inspection and maintenance plan, to return the unit to compliant operation. All repairs and maintenance activities for each unit must be recorded in a maintenance and repair log and must be available for inspection.

(5) Following return to operation from maintenance or repair activity, each device must pass a visual observation according to Method 22 of appendix A-7 to this part as described in paragraph (e)(3) of this section or be monitored according to § 60.5417c(h).

(6) If the owner or operator operates a combustion control device model tested under this section, an electronic copy of the performance test results required by this section shall be submitted via email to *Oil and Gas PT@EPA.GOV* unless the test results for that model of combustion control device are posted at the following website: <https://www.epa.gov/controlling-air-pollution-oil-and-natural-gas-industry>.

(7) Ensure that each enclosed combustion device is maintained in a leak free condition.

(8) Operate each control device following the manufacturer's written operating instructions, procedures, and maintenance schedule to ensure good air pollution control practices for minimizing emissions.

(9) Install and operate the continuous parameter monitoring systems in accordance with § 60.5417c(a) and (c) through (i).

(10) Comply with the applicable NHV limit specified in § 60.5412c(a)(1)(iv).

Model Rule—Continuous Compliance Requirements

§ 60.5415c How do I demonstrate continuous compliance with the standards for each of my designated facilities?

(a) *Gas well liquids unloading standards for well designated facility.* For each well liquids unloading operation at your well designated facility, you must demonstrate continuous compliance with the requirements of § 60.5390c by submitting the annual report information specified in § 60.5420c(b)(1) and (2) and maintaining the records for each well liquids unloading event that vents to the atmosphere as specified in § 60.5420c(c)(1). For each gas well

liquids unloading well affected facility that complies with the requirements of § 60.5390c(g), you must route emissions to a control device through a closed vent system and continuously comply with the closed vent requirements of § 60.5416c. You also must comply with the requirements specified in paragraph (f) of this section and maintain the records in § 60.5420c(c)(7), (9) and (11).

(b) *Associated gas well standards for well designated facility.* For each associated gas well at your well designated facility, you must demonstrate continuous compliance with the requirements of § 60.5391c by submitting the reports required by § 60.5420c(b)(1) and (3) and maintaining the records specified in § 60.5420c(c)(2). For each associated gas well at your well designated facility that complies with the requirements of § 60.5391c(b) or (c), you must route emissions to a control device through a closed vent system and continuously comply with the closed vent requirements of § 60.5416c. You must also comply with the requirements specified in paragraph (e) of this section and maintain the records in paragraphs (c)(7), (9) and (11) of this section.

(c) *Centrifugal compressor designated facility.* For each centrifugal compressor designated facility complying with the volumetric flow rate measurements requirements in § 60.5392c(a)(1) and (2), you must demonstrate continuous compliance according to paragraph (c)(1) and paragraphs (c)(3) and (4) of this section. Alternatively, for each wet seal and dry seal centrifugal compressor designated facility complying with § 60.5392c(a)(3) and (a)(4) or (5) by routing emissions to a control device or to a process, you must demonstrate continuous compliance according to paragraphs (c)(2) through (4) of this section.

(1) You must maintain volumetric flow rate at or below the volumetric flow rates specified in paragraphs (c)(1)(i) through (iii) of this section for your centrifugal compressor, as applicable, and you must conduct the required volumetric flow rate measurement of your dry or wet seal in accordance with § 60.5392c(a)(1) and (2) on or before 8,760 hours of operation after your last volumetric flow rate measurement which demonstrates compliance with the applicable volumetric flow rate.

(i) For your wet seal centrifugal compressors (including self-contained wet seal centrifugal compressors), you must maintain the volumetric flow rate at or below 3 scfm per seal (or in the case of manifolded groups of seals, 3 scfm multiplied by the number of seals).

(ii) For your Alaska North Slope centrifugal compressor equipped with sour seal oil separator and capture system, you must maintain the volumetric flow rate at or below 9 scfm per seal (or in the case of manifolded groups of wet seals, 9 scfm multiplied by the number of seals).

(iii) For your dry seal compressor, you must maintain the volumetric flow rate at or below 10 scfm per seal (or in the case of manifolded groups of wet seals, 10 scfm multiplied by the number of seals).

(2) For each wet seal and dry seal centrifugal compressor designated facility complying by routing emissions to a control device or to a process, you must operate the wet seal emissions collection system and dry seal system to route emissions to a control device or a process through a closed vent system and continuously comply with the closed vent requirements of § 60.5416c(a) and (b). If you comply with § 60.5392c(a)(4) by using a control device, you also must comply with the requirements in paragraph (e) of this section.

(3) You must submit the annual reports as required in § 60.5420c(b)(1), (4) and (10)(i) through (iv), as applicable.

(4) You must maintain records as required in § 60.5420c(c)(3), (7) through (9) and (11), as applicable.

(d) *Pump designated facility.* To demonstrate continuous compliance with the GHG standards for your pump designated facility as required by § 60.5395c, you must comply with paragraphs (d)(1) through (3) of this section.

(1) For pump designated facilities complying with the requirements of § 60.5395c(a) by routing emissions to a process and for pump designated facilities complying with the requirements of § 60.5395c(b)(1) or (3), you must continuously comply with the closed vent requirements of § 60.5416c(a) and (b). If you comply with § 60.5395c(b)(3), you also must comply with the requirements in paragraph (d) of this section.

(2) You must submit the annual reports for your pump designated facility as required in § 60.5420c(b)(1), and (9) through (12), as applicable.

(3) You must maintain the records for your pump designated facility as specified in § 60.5420c(c)(14), as applicable.

(e) *Additional continuous compliance requirements for well, centrifugal compressor, reciprocating compressor, process controllers in Alaska, storage vessel, process unit equipment, or pump designated facilities.* For each associated

gas well at your well designated facility, each gas well liquids unloading operation at your well designated facility, each centrifugal compressor designated facility, each reciprocating compressor designated facility, each process controller designated facility in Alaska, each storage vessel designated facility, each process unit equipment designated facility, and each pump designated facility referenced to this paragraph from either paragraph (a), (b), (c)(2), (d)(1), (f), (g)(2)(iv), (h) or (i) of this section, you must also install monitoring systems as specified in § 60.5417c, demonstrate continuous compliance according to paragraph (e)(1) of this section, maintain the records in paragraph (e)(2) of this section, and comply with the reporting requirements specified in paragraph (e)(3) of this section.

(1) You must demonstrate continuous compliance with the control device performance requirements of § 60.5412c(a) using the procedures specified in paragraphs (e)(1)(i) through (viii) of this section and conducting the monitoring as required by § 60.5417c. If you use a condenser as the control device to achieve the requirements specified in § 60.5412c(a)(2), you may demonstrate compliance according to paragraph (e)(1)(ix) of this section. You may switch between compliance with paragraphs (e)(1)(i) through (viii) of this section and compliance with paragraph (e)(1)(ix) of this section only after at least 1 year of operation in compliance with the selected approach. You must provide notification of such a change in the compliance method in the next annual report, following the change. If you use an enclosed combustion device or a flare as the control device, you must also conduct the monitoring required in paragraph (e)(1)(x) of this section. If you use an enclosed combustion device or flare using an alternative test method approved under § 60.5412c(d), you must use the procedures in paragraph (e)(1)(xi) of this section in lieu of the procedures in paragraphs (e)(1)(i) through (viii) of this section, but you must still conduct the monitoring required in paragraph (e)(1)(x) of this section.

(i) You must operate below (or above) the site-specific maximum (or minimum) parameter value established according to the requirements of § 60.5417c(f)(1). For flares, you must operate above the limits specified in paragraphs (e)(1)(vii)(B) of this section.

(ii) You must calculate the average of the applicable monitored parameter in accordance with § 60.5417c(e).

(iii) Compliance with the operating parameter limit is achieved when the

average of the monitoring parameter value calculated under paragraph (e)(1)(ii) of this section is either equal to or greater than the minimum parameter value or equal to or less than the maximum parameter value established under paragraph (e)(1)(i) of this section. When performance testing of a combustion control device is conducted by the device manufacturer as specified in § 60.5413c(d), compliance with the operating parameter limit is achieved when the criteria in § 60.5413c(e) are met.

(iv) You must operate the continuous monitoring system required in § 60.5417c(a) at all times the affected source is operating, except for periods of monitoring system malfunctions, repairs associated with monitoring system malfunctions and required monitoring system quality assurance or quality control activities (including, as applicable, system accuracy audits and required zero and span adjustments). A monitoring system malfunction is any sudden, infrequent, not reasonably preventable failure of the monitoring system to provide valid data. Monitoring system failures that are caused in part by poor maintenance or careless operation are not malfunctions. You are required to complete monitoring system repairs in response to monitoring system malfunctions and to return the monitoring system to operation as expeditiously as practicable.

(v) You may not use data recorded during monitoring system malfunctions, repairs associated with monitoring system malfunctions, or required monitoring system quality assurance or control activities in calculations used to report emissions or operating levels. You must use all the data collected during all other required data collection periods to assess the operation of the control device and associated control system.

(vi) Failure to collect required data is a deviation of the monitoring requirements.

(vii) If you use an enclosed combustion device to meet the requirements of § 60.5412c(a)(1) and you demonstrate compliance using the test procedures specified in § 60.5413c(b), or you use a flare designed and operated in accordance with § 60.5412c(a)(3), you must comply with the applicable requirements in paragraphs (e)(1)(vii)(A) through (E) of this section.

(A) For each enclosed combustion device which is not a catalytic vapor incinerator and for each flare, you must comply with the requirements in

paragraphs (e)(1)(vii)(A)(1) through (4) of this section.

(1) A pilot or combustion flame must be present at all times of operation. An alert must be sent to the nearest control room whenever the pilot or combustion flame is unlit.

(2) Devices must be operated with no visible emissions, except for periods not to exceed a total of 1 minute during any 15-minute period. A visible emissions test conducted according to section 11 of Method 22 of appendix A-7 to this part, must be performed at least once every calendar month, separated by at least 15 days between each test. The observation period shall be 15 minutes or once the amount of time visible emissions is present has exceeded 1 minute, whichever time period is less. Alternatively, you may conduct visible emissions monitoring according to § 60.5417c(h).

(3) Devices failing the visible emissions test must follow manufacturer's repair instructions, if available, or best combustion engineering practice as outlined in the unit inspection and maintenance plan, to return the unit to compliant operation. All repairs and maintenance activities for each unit must be recorded in a maintenance and repair log and must be available for inspection.

(4) Following return to operation from maintenance or repair activity, each device must pass a Method 22 of appendix A-7 to this part visual observation as described in paragraph (e)(1)(vii)(D) of this section or be monitored according to § 60.5417c(h).

(B) For flares, you must comply with the requirements in paragraphs (e)(1)(vii)(B)(1) through (6) of this section.

(1) For unassisted flares, maintain the NHV of the gas sent to the flare at or above 200 Btu/scf.

(2) If you use a pressure assisted flare, maintain the NHV of gas sent to the flare at or above 800 Btu/scf.

(3) For steam-assisted and air-assisted flares, maintain the NHV_{cz} at or above 270 Btu/scf.

(4) For flares with perimeter assist air, maintain the NHV_{dil} at or above 22 Btu/sqft. If the only assist air provided to the flare is perimeter assist air intentionally entrained in lower and/or upper steam at the flare tip and the effective diameter is 9 inches or greater, you are not required to comply with the NHV_{dil} limit.

(5) Unless you use a pressure-assisted flare, maintain the flare tip velocity below the applicable limits in § 60.18(b).

(6) Maintain the total gas flow to the flare above the minimum inlet gas flow

rate. The minimum inlet gas flow rate is established based on manufacturer recommendations.

(C) For enclosed combustion devices for which, during the performance test conducted under § 60.5413c(b), the combustion zone temperature is not an indicator of destruction efficiency, you must comply with the requirements in paragraphs (e)(1)(vii)(C)(1) through (5) of this section, as applicable.

(1) Maintain the total gas flow to the enclosed combustion device at or above the minimum inlet gas flow rate and at or below the maximum inlet flow rate for the enclosed combustion device established in accordance with § 60.5417c(f).

(2) For unassisted enclosed combustion devices, maintain the NHV of the gas sent to the enclosed combustion device at or above 200 Btu/scf.

(3) For enclosed combustion devices that use pressure-assisted burner tips to promote mixing at the burner tip, maintain the NHV of the gas sent to the enclosed combustion device at or above 800 Btu/scf.

(4) For steam-assisted and air-assisted enclosed combustion devices, maintain the NHV_{cz} at or above 270 Btu/scf.

(5) For enclosed combustion devices with perimeter assist air, maintain the NHV_{dil} at or above 22 Btu/sqft. If the only assist air provided to the enclosed combustion device is perimeter assist air intentionally entrained in lower and/or upper steam at the flare tip and the effective diameter is 9 inches or greater, you are not required to comply with the NHV_{dil} limit.

(D) For enclosed combustion devices for which, during the performance test conducted under § 60.5413c(b), the combustion zone temperature is demonstrated to be an indicator of destruction efficiency, you must comply with the requirements in paragraphs (e)(1)(vii)(D)(1) and (2) of this section.

(1) Maintain the temperature at or above the minimum temperature established during the most recent performance test. The minimum temperature limit established during the most recent performance test is the average temperature recorded during each test run, averaged across the 3 test runs (average of the test run averages).

(2) Maintain the total gas flow to the enclosed combustion device at or above the minimum inlet gas flow rate and at or below the maximum inlet flow rate for the enclosed combustion device established in accordance with § 60.5417c(f).

(E) For catalytic vapor incinerators you must operate the catalytic vapor incinerator at or above the minimum

temperature of the catalyst bed inlet and at or above the minimum temperature differential between the catalyst bed inlet and the catalyst bed outlet established in accordance with § 60.5417c(f).

(viii) If you use a carbon adsorption system as the control device to meet the requirements of § 60.5412c(a)(2), you must demonstrate compliance by the procedures in paragraphs (e)(1)(viii)(A) and (B) of this section, as applicable.

(A) If you use a regenerative-type carbon adsorption system, you must comply with paragraphs (e)(1)(viii)(A)(1) through (4) of this section.

(1) You must maintain the average regenerative mass flow or volumetric flow to the carbon adsorber during each bed regeneration cycle above the limit established in accordance with § 60.5413c(c)(2).

(2) You must maintain the average carbon bed temperature above the temperature limit established in accordance with § 60.5413c(c)(2) during the carbon bed steaming cycle and below the carbon bed temperature established in accordance with § 60.5413c(c)(2) after the regeneration cycle.

(3) You must check the mechanical connections for leakage at least every month, and you must perform a visual inspection at least every 3 months of all components of the continuous parameter monitoring system for physical and operational integrity and all electrical connections for oxidation and galvanic corrosion if your continuous parameter monitoring system is not equipped with a redundant flow sensor.

(4) You must replace all carbon in the carbon adsorption system with fresh carbon on a regular, predetermined time interval that is no longer than the carbon service life established according to § 60.5413c(c)(2).

(B) If you use a nonregenerative-type carbon adsorption system, you must replace all carbon in the control device with fresh carbon on a regular, predetermined time interval that is no longer than the carbon service life established according to § 60.5413c(c)(3).

(ix) If you use a condenser as the control device to achieve the percent reduction performance requirements specified in § 60.5412c(a)(2), you must demonstrate compliance using the procedures in paragraphs (e)(1)(ix)(A) through (E) of this section.

(A) You must establish a site-specific condenser performance curve according to § 60.5417c(f)(2).

(B) You must calculate the daily average condenser outlet temperature in accordance with § 60.5417c(e).

(C) You must determine the condenser efficiency for the current operating day using the daily average condenser outlet temperature calculated under paragraph (e)(1)(ix)(B) of this section and the condenser performance curve established under paragraph (e)(1)(ix)(A) of this section.

(D) Except as provided in paragraphs (e)(1)(ix)(D)(1) and (2) of this section, at the end of each operating day, you must calculate the 365-day rolling average TOC emission reduction, as appropriate, from the condenser efficiencies as determined in paragraph (e)(1)(ix)(C) of this section.

(1) After the compliance dates specified in § 60.5387c(a), if you have less than 120 days of data for determining average TOC emission reduction, you must calculate the average TOC emission reduction for the first 120 days of operation after the compliance date. You have demonstrated compliance with the overall 95.0 percent reduction requirement if the 120-day average TOC emission reduction is equal to or greater than 95.0 percent.

(2) After 120 days and no more than 364 days of operation after the compliance date specified in § 60.5387c(a), you must calculate the average TOC emission reduction as the TOC emission reduction averaged over the number of days between the current day and the applicable compliance date. You have demonstrated compliance with the overall 95.0 percent reduction requirement if the average TOC emission reduction is equal to or greater than 95.0 percent.

(E) If you have data for 365 days or more of operation, you have demonstrated compliance with the TOC emission reduction if the rolling 365-day average TOC emission reduction calculated in paragraph (e)(1)(ix)(D) of this section is equal to or greater than 95.0 percent.

(x) During each inspection conducted using an OGI camera under § 60.5397c and during each periodic screening event or each inspection conducted using an OGI camera under § 60.5398c, you must observe each enclosed combustion device and flare to determine if it is operating properly. You must determine whether there is a flame present and whether any uncontrolled emissions from the control device are visible with the OGI camera or the technique used to conduct the periodic screening event. During each inspection conducted under § 60.5397c using AVO, you must observe each

enclosed combustion device and flare to determine if it is operating properly. Visually confirm that the pilot or combustion flame is lit and that the pilot or combustion flame is operating properly.

(xi) If you use an enclosed combustion device or flare using an alternative test method approved under § 60.5412c(d), you must comply with paragraphs (e)(1)(xi)(A) through (E) of this section.

(A) You must maintain the combustion efficiency at or above 95.0 percent. Alternatively, if the alternative test method does not directly monitor combustion efficiency, you must comply with the applicable requirements in paragraphs (e)(1)(xi)(A)(1) and (2) of this section.

(1) Maintain the NHV_{cz} at or above 270 Btu/scf.

(2) For flares or enclosed combustion devices with perimeter assist air, maintain the NHV_{dil} at or above 22 Btu/sqft. If the only assist air provided to the flare or enclosed combustion device is perimeter assist air intentionally entrained in lower and/or upper steam at the flare tip and the effective diameter is 9 inches or greater, you are only required to comply with the NHV_{cz} limit specified in paragraph (e)(1)(xi)(A)(1) of this section.

(B) You must calculate the value of the applicable monitored metric(s) in accordance with the approved alternative test method. Compliance with the limit is achieved when the calculated values are within the range specified in paragraph (e)(1)(xi)(A) of this section.

(C) You must conduct monitoring using the alternative test method at all times the affected source is operating, except for periods of monitoring system malfunctions, repairs associated with monitoring system malfunctions and required monitoring system quality assurance or quality control activities (including, as applicable, system accuracy audits and required zero and span adjustments). A monitoring system malfunction is any sudden, infrequent, not reasonably preventable failure of the monitoring system to provide valid data. Monitoring system failures that are caused in part by poor maintenance or careless operation are not malfunctions. You are required to complete monitoring system repairs in response to monitoring system malfunctions and to return the monitoring system to operation as expeditiously as practicable.

(D) You may not use data recorded during monitoring system malfunctions, repairs associated with monitoring system malfunctions, or required

monitoring system quality assurance or control activities in calculations used to report values to demonstrate compliance with the limits specified in paragraph (e)(1)(xi)(A) of this section. You must use all the data collected during all other required data collection periods to assess the operation of the control device and associated control system.

(E) Failure to collect required data is a deviation of the monitoring requirements.

(2) You must maintain the records as specified in § 60.5420c(c)(10) and (12).

(3) You must comply with the reporting requirements in § 60.5420c(b)(10) through (12).

(f) *Reciprocating compressor designated facility.* For each reciprocating compressor designated facility complying with § 60.5393c(a) through (c), you must demonstrate continuous compliance according to paragraphs (f)(1), (3) and (4) of this section. For each reciprocating compressor designated facility complying with § 60.5393c(d), you must demonstrate continuous compliance according to paragraph (f)(4) through (6) of this section. For each reciprocating compressor affected facility complying with § 60.5393c(d)(2), you must demonstrate continuous compliance according to paragraphs (g)(3) through (6) of this section.

(1) You must maintain the volumetric flow rate at or below 2 scfm per cylinder (or at or below the combined volumetric flow rate determined by multiplying the number of cylinders by 2 scfm), and you must conduct the required volumetric flow rate measurement of your reciprocating compressor rod packing vents in accordance with § 60.5393c(b) on or before 8,760 hours of operation after your last volumetric flow rate measurement which demonstrated compliance with the applicable volumetric flow rate.

(2) You must operate the rod packing emissions collection system to route emissions to a control device or to a process through a closed vent system and continuously comply with the cover and closed vent requirements of § 60.5416c. If you comply with § 60.5393c(d) by using a control device, you also must comply with the requirements in paragraph (e) of this section.

(3) You must continuously monitor the number of hours of operation for each reciprocating compressor affected facility since initial startup, since 60 days after the state plan submittal deadline (as specified in § 60.5362c(c)), since the previous flow rate measurement, or since the date of the

most recent reciprocating compressor rod packing replacement, whichever date is latest.

(4) You must replace the reciprocating compressor rod packing on or before the total number of hours of operation reaches 8,760 hours.

(5) You must submit the annual reports as required in § 60.5420c(b)(1), (5), and (b)(10)(i) through (iv), as applicable.

(6) You must maintain records as required in § 60.5420c(c)(4), (7), (9), and (11), as applicable.

(g) *Process controller designated facility.* To demonstrate continuous compliance with GHG emission standards for your process controller designated facility as required by § 60.5394c, you must comply with the paragraphs (g)(1) through (4) of this section.

(1) You must demonstrate that your process controller designated facility does not emit any methane to the atmosphere by meeting the requirements of paragraphs (g)(1)(i) or (ii) of this section.

(i) If you comply by routing the emissions to a process, you must comply with the closed vent system inspection and monitoring requirements of § 60.5416c.

(ii) If you comply by using a self-contained natural gas-driven process controller, you must conduct the no identifiable emissions inspections required by § 60.5416c(b).

(2) For each process controller designated facility located at a site in Alaska that does not have access to electrical power, and that complies by reducing methane emissions from all controllers in the process controller designated facility by 95.0 percent in accordance with § 60.5494c(b)(3), you must comply with the closed vent requirements of § 60.5416c and the requirements in paragraph (f) of this section for the control device.

(3) You must submit the annual report for your process controller as required in § 60.5420c(b)(1), (6), and (10) through (12), as applicable.

(4) You must maintain the records as specified in § 60.5420c(c)(5) for each process controller designated facility, as applicable.

(h) *Storage vessel designated facility.* For each storage vessel designated facility, you must demonstrate continuous compliance with the requirements of § 60.5396c according to paragraphs (h)(1) through (10) of this section, as applicable.

(1) For each storage vessel designated facility complying with the requirements of § 60.5396c(a)(2), you must demonstrate continuous

compliance according to paragraphs (h)(5) and (h)(9) and (10) of this section.

(2) For each storage vessel designated facility complying with the requirements of § 60.5396c(a)(3), you must demonstrate continuous compliance according to paragraphs (h)(2)(i), (ii), or (iii) of this section, as applicable, and (h)(9) and (10) of this section.

(i) You must maintain the uncontrolled actual methane emissions from the storage vessel designated facility at less than 14 tpy.

(ii) You must comply with paragraph (h)(5) of this section as soon as liquids from the well are routed to the storage vessel designated facility following fracturing or refracturing according to the requirements of § 60.5396c(a)(3)(i).

(iii) You must comply with paragraph (h)(5) of this section within 30 days of the monthly determination according to the requirements of § 60.5396c(a)(3)(ii), where the monthly emissions determination indicates that methane emissions from your storage vessel designated facility increase to 14 tpy or greater and the increase is not associated with fracturing or refracturing of a well feeding the storage vessel designated facility.

(3) For each storage vessel designated facility or portion of a storage vessel designated facility removed from service, you must demonstrate compliance with the requirements of § 60.5396c(c)(1), by complying with paragraphs (h)(6) and (7) and (h)(9) and (10) of this section.

(4) For each storage vessel designated facility or portion of a storage vessel designated facility returned to service, you must demonstrate compliance with the requirements of § 60.5396c(c)(1) by complying with paragraphs (h)(8) through (10) of this section.

(5) For each storage vessel designated facility, you must comply with paragraphs (h)(5)(i) and (ii) of this section.

(i) You must reduce methane emissions as specified in § 60.5396c(a)(2).

(ii) For each control device installed to meet the requirements of § 60.5396c(a)(2), you must demonstrate continuous compliance with the performance requirements of § 60.5412c for each storage vessel designated facility using the procedure specified in paragraph (h)(5)(ii)(A) and (B) of this section. When routing emissions to a process, you must demonstrate continuous compliance as specified in paragraph (h)(5)(ii)(A) of this section.

(A) You must comply with § 60.5416c for each cover and closed vent system.

(B) You must comply with the requirements specified in paragraph (e) of this section.

(6) You must completely empty and degas each storage vessel, such that each storage vessel no longer contains crude oil, condensate, produced water or intermediate hydrocarbon liquids. For a portion of a storage vessel designated facility to be removed from service, you must completely empty and degas the storage vessel(s), such that the storage vessel(s) no longer contains crude oil, condensate, produced water or intermediate hydrocarbon liquids. A storage vessel where liquid is left on walls, as bottom clingage or in pools due to floor irregularity is considered to be completely empty.

(7) You must disconnect the storage vessel(s) from the tank battery by isolating the storage vessel(s) from the tank battery such that the storage vessel(s) is no longer manifolded to the tank battery by liquid or vapor transfer.

(8) You must determine the designated facility status of a storage vessel returned to service as provided in § 60.5386c(e)(5).

(9) You must submit the annual reports as required by § 60.5420c(b)(1) and (7).

(10) You must maintain the records as required by § 60.5420c(c)(6) through (9), and (11), as applicable.

(i) *Process unit equipment designated facility.* For each process unit equipment designated facility, you must demonstrate continuous compliance with the requirements of § 60.5400c according to paragraphs (i)(1) through (4) and (11) through (16) of this section, unless you meet and comply with the exception in § 60.5402c(b), (e), or (f) or meet the exemption in § 60.5402c(c). Alternatively, if you comply with the GHG standards for process unit designated facilities using the standards in § 60.5401c, you must comply with paragraphs (i)(5) through (16) of this section, unless you meet the exemption in § 60.5402c(b) or (c) or the exception in § 60.5402c(e) and (f).

(1) You must conduct monitoring for each pump in light liquid service, pressure relief device in gas/vapor service, valve in gas/vapor and light liquid service and connector in gas/vapor and light liquid service as required by § 60.5400c(b).

(2) You must conduct monitoring as required by § 60.5400c(c) for each pump in light liquid service.

(3) You must conduct monitoring as required by § 60.5400c(d) for each pressure relief device in gas/vapor service.

(4) You must comply with the equipment requirements for each open-

ended valve or line as required by § 60.5400c(e).

(5) You must conduct monitoring for each pump in light liquid service as required by § 60.5401c(b).

(6) You must conduct monitoring for each pressure relief device in gas/vapor service as required by § 60.5401c(c).

(7) You must comply with the equipment requirements for each open-ended valve or line as required by § 60.5401c(d).

(8) You must conduct monitoring for each valve in gas/vapor or light liquid service as required by § 60.5401c(f).

(9) You must conduct monitoring for each pump, valve, and connector in heavy liquid service and each pressure relief device in light liquid or heavy liquid service as required by § 60.5401c(g).

(10) You must conduct monitoring for each connector in gas/vapor or light liquid service as required by § 60.5401c(h).

(11) You must collect emissions and meet the closed vent system requirements as required by § 60.5416c for each pump equipped with a dual mechanical seal system that degasses the barrier fluid reservoir to a process or a control device, each pump which captures and transports leakage from the seal or seals to a process or control device, or each pressure relief device which captures and transports leakage through the pressure relief device to a process or control device.

(12) You must comply with the requirements specified in paragraph (f) of this section.

(13) You must tag and repair each identified leak as required in § 60.5400c(h) or § 60.5400c(i), as applicable.

(14) You must submit semiannual reports as required by § 60.5422c and the annual reports in § 60.5420b(b)(10)(i) through (iv), as applicable.

(15) You must maintain the records specified by § 60.5420c(c)(7), (c)(9), and (c)(11) as applicable and § 60.5421c.

(j) *Continuous compliance.* For each fugitive emissions components designated facility, you must demonstrate continuous compliance with the requirements of § 60.5397c(a) according to paragraphs (j)(1) through (4) of this section.

(1) You must conduct periodic monitoring surveys as required in § 60.5397c(e) and (g).

(2) You must repair each identified source of fugitive emissions as required in § 60.5397c(h).

(3) You must submit annual reports for fugitive emissions components

designated facilities as required in § 60.5420c(b)(1) and (8).

(4) You must maintain records as specified in § 60.5420c(c)(15).

§ 60.5416c What are the initial and continuous cover and closed vent system inspection and monitoring requirements?

For each closed vent system and cover at your well, centrifugal compressor, reciprocating compressor, process controller, pump, storage vessel, and process unit equipment designated facilities, you must comply with the applicable requirements of paragraphs (a) and (b) of this section. Each self-contained natural gas process controller must comply with paragraph (b) of this section.

(a) *Inspections for closed vent systems, covers, and bypass devices.* If you install a control device or route emissions to a process, you must inspect each closed vent system according to the procedures and schedule specified in paragraphs (a)(1) and (2) of this section, inspect each cover according to the procedures and schedule specified in paragraph (a)(3) of this section, and inspect each bypass device according to the procedures of paragraph (a)(4) of this section, except as provided in paragraphs (b)(6) and (7) of this section.

(1) For each closed vent system joint, seam, or other connection that is permanently or semi-permanently sealed (e.g., a welded joint between two sections of hard piping or a bolted and gasketed ducting flange), you must meet the requirements specified in paragraphs (a)(1)(i) through (iii) of this section.

(i) Conduct an initial inspection according to the test methods and procedures specified in paragraph (b) of this section to demonstrate that the closed vent system operates with no identifiable emissions within the first 30 calendar days after routing emissions through the closed vent system.

(ii) Conduct annual visual inspections for defects that could result in air emissions. Defects include, but are not limited to, visible cracks, holes, or gaps in piping; loose connections; liquid leaks; or broken or missing caps or other closure devices. You must monitor a component or connection using the test methods and procedures in paragraph (b) of this section to demonstrate that it operates with no identifiable emissions following any time the component is repaired or replaced or the connection is unsealed.

(iii) Conduct AVO inspections in accordance with and at the same frequency as specified for fugitive emissions components designated facilities located at the same type of site

as specified in § 60.5397c(g). Process unit equipment designated facilities must conduct annual AVO inspections concurrent with the inspections required by paragraph (a)(1)(ii) of this section.

(2) For closed vent system components other than those specified in paragraph (a)(1) of this section, you must meet the requirements of paragraphs (a)(2)(i) through (iv) of this section.

(i) Conduct an initial inspection according to the test methods and procedures specified in paragraph (b) of this section within the first 30 calendar days after routing emissions through the closed vent system to demonstrate that the closed vent system operates with no identifiable emissions.

(ii) Conduct inspections according to the test methods, procedures, and frequencies specified in paragraph (b) of this section to demonstrate that the components or connections operate with no identifiable emissions.

(iii) Conduct annual visual inspections for defects that could result in air emissions. Defects include, but are not limited to, visible cracks, holes, or gaps in ductwork; loose connections; liquid leaks; or broken or missing caps or other closure devices. You must monitor a component or connection using the test methods and procedures in paragraph (b) of this section to demonstrate that it operates with no identifiable emissions following any time the component is repaired or replaced or the connection is unsealed.

(iv) Conduct AVO inspections in accordance with and at the same frequency as specified for fugitive emissions components designated facilities located at the same type of site, as specified in § 60.5397c(g). Process unit equipment designated facilities must conduct annual AVO inspections concurrent with the inspections required by paragraph (a)(2)(iii) of this section.

(3) For each cover, you must meet the requirements of paragraphs (a)(3)(i) through (iv) of this section.

(i) Conduct the inspections specified in paragraphs (a)(3)(ii) through (iv) of this section to identify defects that could result in air emissions and to ensure the cover operates with no identifiable emissions. Defects include, but are not limited to, visible cracks, holes, or gaps in the cover, or between the cover and the separator wall; broken, cracked, or otherwise damaged seals or gaskets on closure devices; and broken or missing hatches, access covers, caps, or other closure devices. In the case where the storage vessel is buried partially or entirely

underground, you must inspect only those portions of the cover that extend to or above the ground surface, and those connections that are on such portions of the cover (e.g., fill ports, access hatches, gauge wells, etc.) and can be opened to the atmosphere.

(ii) An initial inspection according to the test methods and procedures specified in paragraph (b) of this section, following installation of the cover to demonstrate that each cover operates with no identifiable emissions.

(iii) Conduct AVO inspections in accordance with and at the same frequency as specified for fugitive emissions components designated facilities located at the same type of site as specified in § 60.5397b(g). Process unit equipment designated facilities must conduct annual AVO inspections concurrent with the inspections required by paragraph (a)(1)(ii) of this section.

(iv) Inspections according to the test methods, procedures, and schedules specified in paragraph (b) of this section to demonstrate that each cover operates with no identifiable emissions.

(4) For each bypass device, except as provided for in § 60.5411c(a)(4)(ii), you must meet the requirements of paragraph (a)(4)(i) or (ii) of this section.

(i) Set the flow indicator to take a reading at least once every 15 minutes at the inlet to the bypass device that could divert the stream away from the control device and to the atmosphere.

(ii) If the bypass device valve installed at the inlet to the bypass device is secured in the non-diverting position using a car-seal or a lock-and-key type configuration, visually inspect the seal or closure mechanism at least once every month to verify that the valve is maintained in the non-diverting position and the vent stream is not diverted through the bypass device.

(b) *No identifiable emissions test methods and procedures.* If you are required to conduct an inspection of a closed vent system and cover as specified in paragraph (a)(1), (2), or (3) of this section or § 60.5398c(b), you must meet the requirements of paragraphs (b)(1) through (9) of this section. You must meet the requirements of paragraphs (b)(1), (2), (4), and (9) of this section for each self-contained process controller at your process controller designated facility as specified at § 60.5394c(a)(2).

(1) *Initial and periodic inspection.* You must conduct initial and periodic no identifiable emissions inspections as specified in paragraphs (b)(1)(i) through (iii) of this section, as applicable.

(i) You must conduct inspections for no identifiable emissions from your

closed vent systems and covers at your well, centrifugal compressor, reciprocating compressor, process controller, pump, or storage vessel designated facility, using the procedures for conducting OGI inspections in § 60.5397c(c)(7). As an alternative you may conduct inspections in accordance with Method 21 of appendix A-7 to this part. Monitoring must be conducted at the same frequency as specified for fugitive emissions components designated facilities located at the same type of site, as specified in § 60.5397c(g).

(ii) For closed vent systems and covers located at onshore natural gas processing plants, OGI inspections for no identifiable emissions must be conducted initially and bimonthly in accordance with appendix K to this part. As an alternative you must conduct quarterly inspections for no identifiable emissions in accordance with Method 21 of appendix A-7 to this part.

(iii) For your self-contained process controller, you must conduct initial and quarterly inspections for no identifiable emissions using the procedures for conducting OGI inspections in § 60.5397c(c)(7). As an alternative you may conduct quarterly inspections in accordance with Method 21 of appendix A-7 to this part.

(2) *OGI inspection.* Where OGI is used, the closed vent system, cover, or self-contained process controller is determined to operate with no identifiable emissions if no emissions are imaged during the inspection. Emissions imaged by OGI constitute a deviation of the no identifiable emissions standard until an OGI inspection conducted in accordance with this paragraph (b)(2) of this section determines that the closed vent system, cover, or self-contained process controller, as applicable, operates with no identifiable emissions.

(3) *AVO inspection.* Where AVO inspections are required, the closed vent system or cover is determined to operate with no identifiable emissions if no emissions are detected by AVO. Emissions detected by AVO constitute a deviation of the no identifiable emissions standard until an AVO inspection determines that the closed vent system or cover operates with no identifiable emissions.

(4) *Method 21 inspection.* Where Method 21 of appendix A-7 to this part is used for the inspection, the requirements of paragraphs (b)(4)(i) through (vii) of this section apply.

(i) The detection instrument must meet the performance criteria of Method 21 of appendix A-7 to this part, except

that the instrument response factor criteria in section 8.1.1 of Method 21 must be for the average composition of the fluid and not for each individual organic compound in the stream.

(ii) You must calibrate the detection instrument before use on each day of its use by the procedures specified in Method 21 of appendix A-7 to this part.

(iii) Calibration gases must be as specified in paragraphs (b)(4)(iii)(A) and (B) of this section.

(A) Zero air (less than 10 parts per million by volume hydrocarbon in air).

(B) A mixture of methane in air at a concentration less than 500 ppmv.

(iv) You may choose to adjust or not adjust the detection instrument readings to account for the background organic concentration level. If you choose to adjust the instrument readings for the background level, you must determine the background level value according to the procedures in Method 21 of appendix A-7 to this part.

(v) Your detection instrument must meet the performance criteria specified in paragraphs (b)(4)(v)(A) and (B) of this section.

(A) Except as provided in paragraph (b)(4)(v)(B) of this section, the detection instrument must meet the performance criteria of Method 21 of appendix A-7 to this part, except the instrument response factor criteria in section 8.1.1 of Method 21 must be for the average composition of the process fluid, not each individual volatile organic compound in the stream. For process streams that contain nitrogen, air, or other inerts that are not organic hazardous air pollutants or volatile organic compounds, you must calculate the average stream response factor on an inert-free basis.

(B) If no instrument is available that will meet the performance criteria specified in paragraph (b)(4)(v)(A) of this section, you may adjust the instrument readings by multiplying by the average response factor of the process fluid, calculated on an inert-free basis, as described in paragraph (b)(4)(v)(A) of this section.

(vi) You must determine if a potential leak interface operates with no identifiable emissions, as applicable, using the applicable procedure specified in paragraph (b)(4)(vi)(A) or (B) of this section.

(A) If you choose not to adjust the detection instrument readings for the background organic concentration level, then you must directly compare the maximum organic concentration value measured by the detection instrument to the applicable value for the potential leak interface as specified in paragraph (b)(4)(vii) of this section.

(B) If you choose to adjust the detection instrument readings for the background organic concentration level, you must compare the value of the arithmetic difference between the maximum organic concentration value measured by the instrument and the background organic concentration value as determined in paragraph (b)(4)(iv) of this section with the applicable value for the potential leak interface as specified in paragraph (b)(4)(vii) of this section.

(vii) A closed vent system, cover, or self-contained process controller is determined to operate with no identifiable emissions if the organic concentration value determined in paragraph (b)(4)(vi) of this section is less than 500 ppmv. An organic concentration value determined in paragraph (b)(4)(vi) of this section of greater than or equal to 500 ppmv constitutes a deviation of the no identifiable emissions standard until an inspection conducted in accordance with this paragraph (b)(4) of this section determines that the closed vent system, cover, or self-contained process controller, as applicable, operates with no identifiable emissions.

(5) *Repairs.* Whenever emissions or a defect is detected, you must repair the emissions or defect as soon as practicable according to the requirements of paragraphs (b)(5)(i) through (iii) of this section, except as provided in paragraph (b)(6) of this section.

(i) A first attempt at repair must be made no later than 5 calendar days after the emissions or defect is detected.

(ii) Repair must be completed no later than 30 calendar days after the emissions or defect is detected.

(iii) For covers, grease or another substance compatible with the gasket material must be applied to deteriorating or cracked gaskets to improve the seal while awaiting repair.

(6) *Delay of repair.* Delay of repair of a closed vent system or cover for which emissions or defects have been detected is allowed if the repair is technically infeasible without a shutdown, or if you determine that emissions resulting from immediate repair would be greater than the emissions likely to result from delay of repair. You must complete repair of such equipment by the end of the next shutdown.

(7) *Unsafe to inspect requirements.* You may designate any parts of the closed vent system or cover as unsafe to inspect if the requirements of paragraphs (b)(7)(i) and (ii) of this section are met. Unsafe to inspect parts are exempt from the inspection

requirements of paragraphs (a)(1) through (3) of this section.

(i) You determine that the equipment is unsafe to inspect because inspecting personnel would be exposed to an imminent or potential danger as a consequence of complying with paragraphs (a)(1), (2), or (3) of this section.

(ii) You have a written plan that requires inspection of the equipment as frequently as practicable during safe-to-inspect times.

(8) *Difficult to inspect requirements.* You may designate any parts of the closed vent system or cover as difficult to inspect if the requirements of paragraphs (b)(8)(i) and (ii) of this section are met. Difficult to inspect parts are exempt from the inspection requirements of paragraphs (a)(1) through (3) of this section.

(i) You determine that the equipment cannot be inspected without elevating the inspecting personnel more than 2 meters above a support surface.

(ii) You have a written plan that requires inspection of the equipment at least once every 5 years.

(9) *Records and reports.* You must maintain records of all inspection results as specified in § 60.5420c(c)(7) through (9). You must submit the reports as specified in § 60.5420c(b)(10).

§ 60.5417c What are the continuous monitoring requirements for my control devices?

You must meet the requirements of this section to demonstrate continuous compliance for each control device used to meet emission standards for your well, centrifugal compressor, reciprocating compressor, process controller, storage vessel, and process unit equipment designated facilities.

(a) For each control device used to comply with the emission reduction standard in § 60.5391c(b) for well designated facilities, § 60.5392c(a)(3) for centrifugal compressor designated facilities, § 60.5393c(d)(2) for reciprocating compressor designated facilities, § 60.5394c(b)(3) for your process controller designated facility in Alaska, § 60.5393c(b)(1) for your pumps designated facility, § 60.5396c(a)(2) for your storage vessel designated facility, or either § 60.5400c(f) or § 60.5401c(e) for your process equipment designated facility, you must install and operate a continuous parameter monitoring system for each control device as specified in paragraphs (c) through (h) of this section, except as provided for in paragraph (b) of this section. If you install and operate a flare in accordance with § 60.5412c(a)(3), you are exempt from the requirements of paragraph (f)

of this section. If you operate an enclosed combustion device or flare using an alternative test method approved under § 60.5412c(d), you must operate the control device as specified in paragraph (i) of this section instead of using the procedures specified in paragraphs (c) through (h) of this section. You must keep records and report in accordance with paragraph (j) of this section.

(b) You are exempt from the monitoring requirements specified in paragraphs (c) through (g) of this section for the control devices listed in paragraphs (b)(1) and (2) of this section.

(1) A boiler or process heater in which all vent streams are introduced with the primary fuel or are used as the primary fuel.

(2) A boiler or process heater with a design heat input capacity equal to or greater than 44 megawatts.

(c) You must meet the specifications and requirements of paragraphs (c)(1) through (4) of this section.

(1) Except for continuous parameter monitoring systems used to detect the presence of a pilot or combustion flame, each continuous parameter monitoring system must measure data values at least once every hour and record the values for each parameter as required in paragraphs (c)(1)(i) or (ii) of this section. Continuous parameter monitoring systems used to detect the presence of a pilot or combustion flame must record a reading at least once every 5 minutes.

(i) Each measured data value.

(ii) Each block average value for each 1-hour period or shorter periods calculated from all measured data values during each period.

(2) You must prepare a monitoring plan that covers each control device for designated facilities within each company-defined area. The monitoring plan must address the monitoring system design, data collection, and the quality assurance and quality control elements outlined in paragraphs (c)(2)(i) through (v) of this section. You must install, calibrate, operate, and maintain each continuous parameter monitoring system in accordance with the procedures in your monitoring plan. Heat sensing monitoring devices that indicate the continuous ignition of a pilot or combustion flame are exempt from the calibration, quality assurance and quality control requirements of this section.

(i) The performance criteria and design specifications for the monitoring system equipment, including the sample interface, detector signal analyzer, and data acquisition and calculations.

(ii) Sampling interface (e.g., thermocouple) location such that the

monitoring system will provide representative measurements.

(iii) Equipment performance checks, system accuracy audits, or other audit procedures.

(iv) Ongoing operation and maintenance procedures in accordance with provisions in § 60.13(b).

(v) Ongoing recordkeeping procedures in accordance with provisions in § 60.7(f).

(3) You must conduct the continuous parameter monitoring system equipment performance checks, system accuracy audits, or other audit procedures specified in the monitoring plan at least once every 12 months.

(4) You must conduct a performance evaluation of each continuous parameter monitoring system in accordance with the monitoring plan. Heat sensing monitoring devices that indicate the continuous ignition of a pilot or combustion flame are exempt from the calibration, quality assurance and quality control requirements of this section.

(d) You must install, calibrate, operate, and maintain a device equipped with a continuous recorder to measure the values of operating parameters appropriate for the control device as specified in paragraphs (d)(1) through (8) of this section, as applicable. Instead of complying with the requirements in paragraphs (d)(1) through (8) of this section, you may install an organic monitoring device equipped with a continuous recorder that measures the concentration level of organic compounds in the exhaust vent stream from the control device to demonstrate compliance with the applicable performance requirement specified in § 60.5412c(a)(1). The monitor must meet the requirements of Performance Specification 8 or 9 of appendix B to this part. You must install, calibrate, and maintain the monitor according to the manufacturer's specifications and the requirements in Performance Specification 8 or 9. You may also request approval from the Administrator to monitor different operating parameters than those specified in paragraphs (d)(1) through (8) of this section in accordance with § 60.13(i).

(1) For an enclosed combustion device that demonstrates during the performance test conducted under § 60.5413c(b) that combustion zone temperature is an accurate indicator of performance, a temperature monitoring device equipped with a continuous recorder. The monitoring device must have a minimum accuracy of ± 1 percent of the temperature being monitored in degrees Celsius, or ± 2.5 °C, whichever

value is greater. You must install the temperature sensor at a location representative of the combustion zone temperature. You must also comply with the requirements of paragraphs (d)(8)(i), (iv), and (v) of this section.

(2) For a catalytic vapor incinerator, a temperature monitoring device equipped with a continuous recorder. The device must be capable of monitoring temperature at two locations and have a minimum accuracy of ± 1 percent of the temperature being monitored in degrees Celsius, or ± 2.5 °C, whichever value is greater. You must install one temperature sensor in the vent stream at the nearest feasible point to the catalyst bed inlet, and you must install a second temperature sensor in the vent stream at the nearest feasible point to the catalyst bed outlet.

(3) For a boiler or process heater, a temperature monitoring device equipped with a continuous recorder. The temperature monitoring device must have a minimum accuracy of ± 1 percent of the temperature being monitored in degrees Celsius, or ± 2.5 °C, whichever value is greater. You must install the temperature sensor at a location representative of the combustion zone temperature.

(4) For a condenser, a temperature monitoring device equipped with a continuous recorder. The temperature monitoring device must have a minimum accuracy of ± 1 percent of the temperature being monitored in degrees Celsius, or ± 2.5 °C, whichever value is greater. You must install the temperature sensor at a location in the exhaust vent stream from the condenser.

(5) For a regenerative-type carbon adsorption system, a continuous monitoring system that meets the specifications in paragraphs (d)(5)(i) and (ii) of this section. You also must monitor the design carbon service life established using a design analysis performed as specified in § 60.5413c(c)(2).

(i) The continuous parameter monitoring system must measure and record the average total regeneration stream mass flow or volumetric flow during each carbon bed regeneration cycle. The flow sensor must have a measurement sensitivity of 5 percent of the flow rate or 10 cubic feet per minute, whichever is greater. You must check the mechanical connections for leakage at least every month, and you must perform a visual inspection at least every 3 months of all components of the flow continuous parameter monitoring system for physical and operational integrity and all electrical connections for oxidation and galvanic corrosion if your flow continuous parameter

monitoring system is not equipped with a redundant flow sensor; and

(ii) The continuous parameter monitoring system must measure and record the average carbon bed temperature for the duration of the carbon bed steaming cycle and measure the actual carbon bed temperature after regeneration and within 15 minutes of completing the cooling cycle. The temperature monitoring device must have a minimum accuracy of ± 1 percent of the temperature being monitored in degrees Celsius, or ± 2.5 °C, whichever value is greater.

(6) For a nonregenerative-type carbon adsorption system, you must monitor the design carbon replacement interval established using a design analysis performed as specified in § 60.5413c(c)(3). The design carbon replacement interval must be based on the total carbon working capacity of the control device and source operating schedule.

(7) For a combustion control device whose model is tested under § 60.5413c(d), continuous monitoring systems as specified in paragraphs (d)(8)(i) through (iv) and (vi) of this section and visible emission observations conducted as specified in paragraph (d)(8)(v) of this section.

(8) For an enclosed combustion device other than those listed in paragraphs (d)(1) through (3) and (7) of this section or for a flare, continuous monitoring systems as specified in paragraphs (d)(8)(i) through (iv) of this section and visible emission observations conducted as specified in paragraph (d)(8)(v) of this section. Additionally, for enclosed combustion devices or flares that are air-assisted or steam-assisted, the continuous monitoring systems specified in paragraph (d)(8)(vi) of this section.

(i) Continuously monitor at least once every five minutes for the presence of a pilot flame or combustion flame using a device (including, but not limited to, a thermocouple, ultraviolet beam sensor, or infrared sensor) capable of detecting that the pilot or combustion flame is present at all times. An alert must be sent to the nearest control room whenever the pilot or combustion flame is unlit. Continuous monitoring systems used for the presence of a pilot flame or combustion flame are not subject to a minimum accuracy requirement beyond being able to detect the presence or absence of a flame and are exempt from the calibration requirements of this section.

(ii) Except as provided in this paragraph (d)(8)(ii) and paragraph (d)(8)(iii) of this section, use one of the following methods to continuously

determine the NHV of the inlet gas to the enclosed combustion device or flare at standard conditions. If the only inlet gas stream to the enclosed combustion device or flare is associated gas from a well designated facility, the NHV of the inlet stream is considered to be sufficiently above the minimum required NHV for the inlet gas, and you are not required to conduct the continuous monitoring in this paragraph (d)(8)(ii) or the demonstration in paragraph (d)(8)(iii) of this section.

(A) A calorimeter with a minimum accuracy of ± 2 percent of span.

(B) A gas chromatograph that meets the requirements in paragraphs (d)(8)(ii)(B)(1) through (5) of this section.

(1) You must follow the procedure in Performance Specification 9 of appendix B to this part, except that a single daily mid-level calibration check can be used (rather than triplicate analysis), the multi-point calibration can be conducted quarterly (rather than monthly), and the sampling line temperature must be maintained at a minimum temperature of 60 °C (rather than 120 °C). Calibration gas cylinders must be certified to an accuracy of 2 percent and traceable to National Institute of Standards and Technology (NIST) standards.

(2) You must meet the accuracy requirements in Performance

Specification 9 of appendix B to this part.

(3) You must use a calibration gas or multiple gases that includes the compounds that are reasonably expected to be present in the flare gas stream. If multiple calibration gases are necessary to cover all compounds, you must calibrate the instrument on all of the gases. You may only use the compounds used to calibrate the gas chromatograph in the calculation of the vent gas NHV.

(4) In lieu of the calibration gas described in paragraph (d)(8)(ii)(B)(3) of this section, you may use a surrogate calibration gas consisting of hydrogen and C1 through C5 normal hydrocarbons. All of the calibration gases may be combined in one cylinder. If multiple calibration gases are necessary to cover all compounds, you must calibrate the instrument on all of the gases. Use the response factor for the nearest normal hydrocarbon (*i.e.*, n-alkane) in the calibration mixture to quantify unknown components detected in the analysis. Use the response factor for n-pentane to quantify unknown components detected in the analysis that elute after n-pentane.

(5) To determine the NHV of the vent gas, determine the product of the volume fraction of the individual component in the vent gas and the net heating value of that individual component. Sum the products for all

components in the vent gas to determine the NHV for the vent gas. For the net heating value of each individual component, use the net heating value at 25 °C and 1 atmosphere.

(C) A mass spectrometer that meets the requirements in paragraphs (d)(8)(ii)(C)(1) through (6) of this section.

(1) You must meet applicable requirements in Performance Specification 9 of appendix B of this part for continuous monitoring system acceptance including, but not limited to, performing an initial multi-point calibration check at three concentrations following the procedure in Section 10.1. A single daily mid-level calibration check can be used (rather than triplicate analysis), the multi-point calibration can be conducted quarterly (rather than monthly), and the sampling line temperature must be maintained at a minimum temperature of 60 °C (rather than 120 °C). Calibration gas cylinders must be certified to an accuracy of 2 percent and traceable to NIST standards.

(2) The average instrument calibration error (CE) for each calibration compound at any calibration concentration must not differ by more than 10 percent from the certified cylinder gas value. The CE for each component in the calibration blend must be calculated using the following equation:

Equation 1 to paragraph (d)(8)(ii)(C)(2)

$$CE = \frac{C_m - C_a}{C_a} \times 100$$

Where:

C_m = Average instrument response (ppm).

C_a = Certified cylinder gas value (ppm).

(3) You must use a calibration gas or multiple gases that includes the compounds that are reasonably expected to be present in the flare gas stream. If multiple calibration gases are necessary to cover all compounds, you must calibrate the instrument on all of the gases. You may only use the compounds used to calibrate the mass spectrometer in the calculation of the vent gas NHV.

(4) In lieu of the calibration gas described in paragraph (d)(8)(ii)(C)(3) of this section, you may use a surrogate calibration gas consisting of hydrogen and C1 through C5 normal hydrocarbons. All of the calibration gases may be combined in one cylinder. If multiple calibration gases are

necessary to cover all compounds, you must calibrate the instrument on all of the gases. For unknown gas components that have similar analytical mass fragments to calibration compounds, you may report the unknowns as an increase in the overlapped calibration gas compound. For unknown compounds that produce mass fragments that do not overlap calibration compounds, you may use the response factor for the nearest molecular weight hydrocarbon in the calibration mix to quantify the unknown component. You may use the response factor for n-pentane to quantify any unknown components detected with a higher molecular weight than n-pentane.

(5) You must perform an initial calibration to identify mass fragment overlap and response factors for the target compounds.

(6) To determine the NHV of the vent gas, determine the product of the volume fraction of the individual component in the vent gas and the net heating value of that individual component. Sum the products for all components in the vent gas to determine the NHV for the vent gas. For the net heating value of each individual component, use the net heating value at 25 °C and 1 atmosphere.

(D) A grab sampling system capable of collecting an evacuated canister sample for subsequent compositional analysis at least once every eight hours. Subsequent compositional analysis of the samples must be performed according to ASTM D1945–14 (R2019) (incorporated by reference, see § 60.17). To determine the NHV of the vent gas, determine the product of the volume fraction of the individual component in the vent gas and the net heating value of that

individual component. Sum the products for all components in the vent gas to determine the NHV for the vent gas. For the net heating value of each individual component, use the net heating value at 25 °C and 1 atmosphere.

(iii) For an unassisted or pressure-assisted flare or enclosed combustion device, if you demonstrate according to the methods described in paragraphs (d)(8)(iii)(A) through (F) of this section that the NHV of the inlet gas to the enclosed combustion device or flare consistently exceeds the applicable operating limit specified in § 60.5415c(e)(1)(vii)(B) or (C)(1), continuous monitoring of the NHV is not required, but you must conduct the ongoing sampling in paragraph (d)(8)(iii)(G) of this section. For flares and enclosed combustion devices that use only perimeter assist air and do not use steam assist or premix assist air, if you demonstrate according to the methods described in paragraphs (d)(8)(iii)(A) through (F) of this section that the NHV of the inlet gas to the enclosed combustion device or flare consistently exceeds 300 Btu/scf, continuous monitoring of the NHV is not required, but you must conduct the ongoing sampling in paragraph (d)(8)(iii)(G) of this section. For an unassisted or pressure-assisted flare or enclosed combustion device, in lieu of conducting the demonstration outlined in paragraphs (d)(8)(iii)(A) through (D) of this section, you may conduct the demonstration outlined in paragraph (d)(8)(iii)(H) of this section, but you must still comply with paragraphs (d)(8)(iii)(E) through (G) of this section.

(A) Continuously monitor or collect a sample of the inlet gas to the enclosed combustion device or flare twice daily to determine the average NHV of the gas stream for 14 consecutive operating days. If you do not continuously monitor the NHV, the minimum time of collection for each individual sample be at least one hour. Consecutive samples must be separated by at least 6 hours. If inlet gas flow is intermittent such that there are not at least 28 samples over the 14 operating day period, you must continue to collect samples of the inlet gas beyond the 14 operating day period until you collect a minimum of 28 samples.

(B) If you collect samples twice per day, count the number of samples where the NHV value is less than 1.2 times the applicable operating limit specified in § 60.5415c(e)(1)(vii)(B) or (C)(1), or paragraph (d)(8)(iii) of this section (*i.e.*, values that are less than 240, 360, or 960 Btu/scf, as applicable) during the

sample collection period in paragraph (d)(8)(iii)(A) of this section.

(C) If you continuously sample the inlet stream for 14 days, count the number of hourly average NHV values that are less than the applicable operating limit specified in § 60.5415c(e)(1)(vii)(B) or (C)(1), or paragraph (d)(8)(iii) of this section (*i.e.*, values that are less than 200, 300, or 800 Btu/scf, as applicable), during the sample collection period in paragraph (d)(8)(iii)(A) of this section.

(D) If there are no samples counted under paragraph (d)(8)(iii)(B) of this section or there are no hourly values counted under paragraph (d)(8)(iii)(C) of this section, the gas stream is considered to consistently exceed the applicable NHV operating limit and ongoing continuous monitoring is not required.

(E) If process operations are revised that could impact the NHV of the gas sent to the enclosed combustion device or flare, such as the removal or addition of process equipment, and at any time the Administrator requires, re-evaluation of the gas stream must be performed according to paragraphs (d)(8)(iii)(A) through (D) of this section to ensure the gas stream still consistently exceeds the applicable operating limit specified in § 60.5415c(e)(1)(vii)(B) or (C)(1), or paragraph (d)(8)(iii) of this section.

(F) When collecting samples under paragraph (d)(8)(iii)(A) of this section, the owner or operator must account for any sources of inert gases that can be sent to the enclosed combustion device or flare (*e.g.*, streams from compressors in acid gas service, streams from enhanced oil recovery facilities). The report in § 60.5420c(b)(10)(v)(I) and the records of the demonstration in § 60.5420c(c)(10)(vi) must note whether the enclosed combustion device or flare has the potential to receive inert gases, and if so, whether the sampling included periods where the highest percentage of inert gases were sent to the enclosed combustion device or flare. If the introduction of inerts is intermittent and does not occur during the initial demonstration, the introduction of inerts will be considered a revision to process operations that triggers a re-evaluation under paragraph (d)(8)(iii)(E) of this section. If conditions at the site did not allow sampling during periods where the introduction of inert gases was at the highest percentage possible, increasing the percentage of inerts will be considered a revision to process operations that triggers a re-evaluation under paragraph (d)(8)(iii)(E) of this section.

(G) You must collect three samples of the inlet gas to the enclosed combustion device or flare at least once every 5 years. The minimum time of collection for each individual sample must be at least one hour. The samples must be taken during the period with the lowest expected NHV (*i.e.*, the period with the highest percentage of inerts). The first set of periodic samples must be taken, or continuous monitoring commenced, no later than 60 calendar months following the last sample taken under paragraph (d)(8)(iii)(A) of this section. Subsequent periodic samples must be taken, or continuous monitoring commenced, no later than 60 calendar months following the previous sample. If any sample has an NHV value less than 1.2 times the applicable operating limit specified in § 60.5415c(e)(1)(vii)(B) or (C)(1), or paragraph (d)(8)(iii) of this section (*i.e.*, values that are less than 240, 360, or 960 Btu/scf, as applicable), you must conduct the monitoring required by paragraph (d)(8)(ii) of this section.

(H) You may request an alternative test method under § 60.5412c(d) to demonstrate that the flare or enclosed combustion device reduces methane and VOC in the gases vented to the device by 95.0 percent by weight or greater. You must use an alternative test method that demonstrates compliance with the combustion efficiency limit; you may not use an alternative test method that demonstrates compliance with NHV_{cz} and NHV_{dil} in lieu of measuring combustion efficiency directly. You must measure data values at the frequency specified in the alternative test method and conduct the quality assurance and quality control requirements outlined in the alternative test method at the frequency outlined in the alternative test method. You must monitor the combustion efficiency of the flare continuously for 14 days. If there are no values of the combustion efficiency measured by the alternative test method that are less than 95.0 percent, the gas stream is considered to consistently exceed the applicable NHV operating limit, and you are not required to continuously monitor the NHV of the inlet gas to the flare or enclosed combustion device.

(iv) Except as noted in paragraphs (d)(8)(iv)(A) through (E) of this section, a continuous parameter monitoring system for measuring the flow of gas to the enclosed combustion device or flare. You may use direct flow meters or other parameter monitoring systems combined with engineering calculations, such as inlet line pressure, line size, and burner nozzle dimensions, to satisfy this requirement. The

monitoring instrument must have an accuracy of ± 10 percent or better at the maximum expected flow rate.

(A) Pressure-assisted flares and pressure-assisted enclosed combustion devices are not required to have a continuous parameter monitoring system for measuring the inlet flow of gas to the device if you install, calibrate, maintain, and operate a backpressure regulator valve calibrated to open at the minimum pressure set point corresponding to the minimum inlet gas flow rate. The set point must be consistent with manufacturer specifications for minimum flow or pressure and must be supported by an engineering evaluation. At least annually, you must confirm that the backpressure regulator valve set point is correct and consistent with the engineering evaluation and manufacturer specifications and that the valve fully closes when not in the open position.

(B) Unassisted flares are not required to have a continuous parameter monitoring system for measuring the inlet flow of gas to the device if you meet the conditions in paragraphs (d)(8)(iv)(B)(1) and (2) of this section.

(1) You must demonstrate, based on the maximum potential pressure of units manifolded to the flare and applicable engineering calculations for the manifolded closed vent system, that the maximum flow rate to the flare cannot cause the flare tip velocity to exceed 18.3 meter/second (60 feet/second). If there are changes to the process or control device that can be reasonably expected to impact the maximum flow rate to the flare, you must conduct a new demonstration to determine whether the maximum flow rate to the flare is less than 18.3 meter/second (60 feet/second).

(2) You must install, calibrate, maintain, and operate a backpressure regulator valve calibrated to open at the minimum pressure set point corresponding to the minimum inlet gas flow rate. The set point must be consistent with manufacturer specifications for minimum flow or pressure and must be supported by an engineering evaluation. At least annually, you must confirm that the backpressure regulator valve set point is correct and consistent with the engineering evaluation and manufacturer specifications and that the valve fully closes when not in the open position.

(C) Unassisted enclosed combustion devices are not required to have a continuous parameter monitoring system for measuring the inlet flow of gas to the device if you meet the

conditions in paragraphs (d)(8)(iv)(C)(1) and (2) of this section.

(1) You must demonstrate, based on the maximum potential pressure of units manifolded to the enclosed combustion device and applicable engineering calculations for the manifolded closed vent system, that the maximum flow rate to the enclosed combustion device cannot cause the maximum inlet flow rate established in accordance with paragraph (f)(1) of this section to be exceeded. If there are changes to the process or control device that can be reasonably expected to impact the maximum flow rate to the enclosed combustion device, you must conduct a new demonstration to determine whether the maximum flow rate to the enclosed combustor is less than the maximum inlet flow rate established in accordance with paragraph (f)(1) of this section.

(2) You must install, calibrate, maintain, and operate a backpressure regulator valve calibrated to open at the minimum pressure set point corresponding to the minimum inlet gas flow rate. The set point must be consistent with manufacturer specifications for minimum flow or pressure and must be supported by an engineering evaluation. At least annually, you must confirm that the backpressure regulator valve set point is correct and consistent with the engineering evaluation and manufacturer specifications and that the valve fully closes when not in the open position.

(D) Air-assisted flares or enclosed combustion devices that use only perimeter assist air and have no assist steam or pre-mix assist air are not required to have a continuous parameter monitoring system for measuring the inlet flow of gas to the device or the flow of assist air if you meet the conditions in paragraphs (d)(8)(iv)(D)(1) and (2) of this section. For these flares and enclosed combustion devices, NHV_{cz} is assumed to be equal to the vent gas NHV .

(1) You must install, calibrate, maintain, and operate a backpressure regulator valve calibrated to open at the minimum pressure set point corresponding to the minimum inlet gas flow rate. The set point must be consistent with manufacturer specifications for minimum flow or pressure and must be supported by an engineering evaluation. At least annually, you must confirm that the backpressure regulator valve set point is correct and consistent with the engineering evaluation and manufacturer specifications and that the

valve fully closes when not in the open position.

(2) You must demonstrate, based on the maximum flow rate of perimeter assist air to the enclosed combustion device or flare and applicable engineering calculations, that the NHV_{dii} can never be less than the minimum required NHV_{dii} . The demonstration must clearly document why the maximum flow rate of perimeter assist air will never exceed the rate used in the demonstration. You must use the minimum flow rate of vent gas allowed by your backpressure regulator valve and the minimum expected value of the NHV of the inlet gas to the enclosed combustion device or flare based on previous sampling results or process knowledge of the streams sent to the enclosed combustion device or flare in your demonstration. You must update this demonstration if there are changes to the backpressure regulator valve, the backpressure regulator valve set point, or the maximum flow rate of perimeter assist air. You must also update this demonstration if any sampling results of the NHV of the inlet gas to the enclosed combustion device or flare under paragraphs (d)(8)(ii) or (iii) of this section are lower than the NHV vent gas value used in your demonstration.

(E) Air-assisted flares or enclosed combustion devices that use only pre-mix assist air and have no assist steam or perimeter assist air are not required to have a continuous parameter monitoring system for measuring the inlet flow of gas to the device or the flow of assist air if you meet the conditions in paragraphs (d)(8)(iv)(E)(1) and (2) of this section.

(1) You must install, calibrate, maintain, and operate a backpressure regulator valve calibrated to open at the minimum pressure set point corresponding to the minimum inlet gas flow rate. The set point must be consistent with manufacturer specifications for minimum flow or pressure and must be supported by an engineering evaluation. At least annually, you must confirm that the backpressure regulator valve set point is correct and consistent with the engineering evaluation and manufacturer specifications and that the valve fully closes when not in the open position.

(2) You must demonstrate, based on the maximum flow rate of pre-mix assist air to the enclosed combustion device or flare and applicable engineering calculations, that the NHV_{cz} will never be less than the minimum required NHV_{cz} . The demonstration must clearly document why the maximum flow rate of pre-mix assist air will never exceed

the rate used in the demonstration. You must use the minimum flow rate of vent gas allowed by your backpressure regulator valve in and the minimum expected value of the NHV of the inlet gas to the enclosed combustion device or flare based on previous sampling results or process knowledge of the streams sent to the enclosed combustion device or flare in your demonstration. You must update this demonstration if there are changes to the backpressure regulator valve, the backpressure regulator valve set point, or the maximum flow rate of pre-mix assist air. You must also update this demonstration if any sampling results of the NHV of the inlet gas to the enclosed combustion device or flare under paragraphs (d)(8)(ii) or (iii) of this section are lower than the NHV vent gas value used in your demonstration.

(v) Conduct inspections monthly and at other times as requested by the Administrator to monitor for visible emissions from the combustion device using section 11 of Method 22 of appendix A to this part or conduct visible emissions monitoring according to paragraph (h) of this section. The observation period shall be 15 minutes or once the amount of time visible emissions is present has exceeded 1 minute. Devices must be operated with no visible emissions, except for periods not to exceed a total of 1 minute during any 15-minute period.

(vi) If you use a flare or enclosed combustion device that is air-assisted or steam-assisted, you must also meet the following requirements.

(A) Except as allowed by paragraph (d)(8)(iv)(E) of this section, you must monitor and calculate NHV_{cz} as specified in § 63.670(m) of this chapter. Additionally, for flares and enclosed combustion devices that use only perimeter assist air and do not use steam assist or pre-mix assist air, the NHV_{cz} is equal to the vent gas NHV. When NHV_{cz} is equal to the vent gas NHV, you are not required to continuously monitor NHV_{cz} if you meet the requirements in paragraph (d)(8)(iii) of this section.

(B) Except as allowed by paragraph (d)(8)(iv)(D) of this section, for each flare using perimeter assist air, you must also monitor and calculate NHV_{dil} as specified in § 63.670(n) of this chapter. If the only assist air provided to the flare or enclosed combustion control device is perimeter assist air intentionally entrained in lower and/or upper steam at the flare tip and the effective diameter is 9 inches or greater, you are only required to comply with the NHV_{cz} limit specified in paragraph (f)(8)(vi)(A) of this section.

(C) Except as allowed by paragraph (d)(8)(iv) of this section, you must monitor the flare vent gas and assist gas as specified in § 63.670(i) of this chapter.

(D) You must determine the flare vent gas net heating value as specified in § 63.670(l) of this chapter using one of the methods specified in paragraph (d)(8)(ii) of this section. Where the phrase “petroleum refinery” is used, for purposes of this subpart, it will refer to flares controlling an affected facility under this subpart. If you are not required to continuously monitor the NHV of the inlet gas because you have demonstrated that it consistently exceeds the applicable operating limit as provided in paragraph (d)(8)(iii) of this section, you must use the lowest net heating value measured in the sampling program in paragraph (d)(8)(iii) of this section for the calculations performed in paragraphs (d)(8)(vi)(A) and (B) of this section. You must update this value if a subsequent sampling result of the NHV of the inlet gas to the enclosed combustion device or flare under paragraph (d)(8)(iii) of this section is lower than the NHV vent gas value used in your calculations.

(e) Calculate the value of the applicable monitored parameter in accordance with paragraphs (e)(1) through (5) of this section.

(1) You must calculate the daily average value for condenser outlet temperature for each operating day, using the data recorded by the monitoring system. If the emissions unit operation is continuous, the operating day is a 24-hour period. If the emissions unit operation is not continuous, the operating day is the total number of hours of control device operation per 24-hour period. Valid data points must be available for 75 percent of the operating hours in an operating day to compute the daily average.

(2) You must use the 5-minute readings from the heat sensing devices to assess the presence of a pilot or combustion flame.

(3) You must use the regeneration cycle time (*i.e.*, duration of the carbon bed steaming cycle) for each regenerative-type carbon adsorption system to calculate the average parameter to compare with the maximum steam mass flow or volumetric flow during each carbon bed regeneration cycle and the maximum carbon bed temperature during the steaming cycle. The carbon bed temperature after the regeneration cycle should not be averaged; you must use the carbon bed temperature measured within 15 minutes of completing the cooling cycle to compare with the

minimum carbon bed temperature after the regeneration cycle.

(4) You must use 15-minute blocks to calculate NHV_{cz} and NHV_{dil} .

(5) For all operating parameters others than those described in paragraphs (e)(1) through (4) of this section, you must calculate the 3-hour rolling average of each monitored parameter. For each operating hour, calculate the hourly value of the operating parameter from your continuous monitoring system. Average the three most recent hours of data to determine the 3-hour average. Determine the 3-hour rolling average by recalculating the 3-hour average each hour.

(f) For each operating parameter monitor installed in accordance with the requirements of paragraph (d) of this section, you must comply with paragraph (f)(1) of this section for all control devices. When condensers are installed, you must also comply with paragraph (f)(2) of this section.

(1) You must establish a minimum operating parameter value or a maximum operating parameter value, as appropriate for the control device, to define the conditions at which the control device must be operated to continuously achieve the applicable performance requirements of § 60.5412c(a)(1) or (2). You must establish each minimum or maximum operating parameter value as specified in paragraphs (f)(1)(i) through (iv) of this section.

(i) If you conduct performance tests in accordance with the requirements of § 60.5413c(b) to demonstrate that the control device achieves the applicable performance requirements specified in § 60.5412c(a)(1) or (2), then you must establish the minimum operating parameter value or the maximum operating parameter value based on values measured during the performance test and supplemented, as necessary, by a condenser or carbon adsorption system design analysis or control device manufacturer recommendations or a combination of both. If you operate an enclosed combustion device, you must establish the maximum inlet flow rate based on values measured during the performance test and you may establish the minimum inlet flow rate based on control device manufacturer recommendations.

(ii) If you use a condenser or carbon adsorption system design analysis in accordance with the requirements of § 60.5413c(c) to demonstrate that the control device achieves the applicable performance requirements specified in § 60.5412c(a)(2), then you must establish the minimum operating

parameter value or the maximum operating parameter value based on the design analysis and supplemented, as necessary, by the manufacturer's recommendations.

(iii) If you operate a control device where the performance test requirement was met under § 60.5413c(d) to demonstrate that the control device achieves the applicable performance requirements specified in § 60.5412c(a)(1), then your control device inlet gas flow rate must be equal to or greater than the minimum inlet gas flow rate and equal to or less than the maximum inlet gas flow rate determined by the manufacturer.

(iv) If you operate an enclosed combustion device where the combustion zone temperature is not an indicator of destruction efficiency or a control device where the performance test requirement was met under § 60.5413c(d), you must maintain the NHV of the gas sent to the enclosed combustion device, the NHV_{cz} , and the NHV_{dil} above the applicable limits specified in § 60.5412c(a)(1)(iv)(A) through (D).

(2) If you use a condenser as specified in paragraph (d)(1)(v) of this section, you must establish a condenser performance curve showing the relationship between condenser outlet temperature and condenser control efficiency, according to the requirements of paragraphs (f)(2)(i) and (ii) of this section.

(i) If you conduct a performance test in accordance with the requirements of § 60.5413c(b) to demonstrate that the condenser achieves the applicable performance requirements of § 60.5412c(a)(2), then the condenser performance curve must be based on values measured during the performance test and supplemented as necessary by control device design analysis, or control device manufacturer's recommendations, or a combination or both.

(ii) If you use a control device design analysis in accordance with the requirements of § 60.5413c(c)(1) to demonstrate that the condenser achieves the applicable performance requirements specified in § 60.5412c(a)(2), then the condenser performance curve must be based on the condenser design analysis and supplemented, as necessary, by the control device manufacturer's recommendations.

(g) A deviation for a control device is determined to have occurred when the monitoring data or lack of monitoring data result in any one of the criteria specified in paragraphs (g)(1) through (7) of this section being met. If you

monitor multiple operating parameters for the same control device during the same operating day and more than one of these operating parameters meets a deviation criterion specified in paragraphs (g)(1) through (7) of this section, then a single excursion is determined to have occurred for the control device for that operating day.

(1) A deviation occurs when the average value of a monitored operating parameter determined in accordance with paragraph (e) of this section is less than the minimum operating parameter limit (and, if applicable, greater than the maximum operating parameter limit) established in paragraph (f)(1) of this section; for flares, when the average value of a monitored operating parameter determined in accordance with paragraph (e) of this section is above the limits specified in § 60.5415c(e)(1)(vii)(B); or when the heat sensing device indicates that there is no pilot or combustion flame present for any time period. If you use a backpressure regulator valve to maintain the inlet gas flow to an enclosed combustion device or flare above the minimum value, a deviation occurs if the annual inspection finds that the backpressure regulator valve set point is not set correctly or indicates that the backpressure regulator valve does not fully close when not in the open position.

(2) If you are subject to § 60.5412c(a)(2), a deviation occurs when the 365-day average condenser efficiency calculated according to the requirements specified in § 60.5415c(e)(1)(ix)(D) is less than 95.0 percent.

(3) If you are subject to § 60.5412c(a)(2) and you have less than 365 days of data, a deviation occurs when the average condenser efficiency calculated according to the procedures specified in § 60.5415c(e)(1)(ix)(D)(1) or (2) is less than 95.0 percent.

(4) A deviation occurs when the monitoring data are not available for at least 75 percent of the operating hours in a day.

(5) If the closed vent system contains one or more bypass devices that could be used to divert all or a portion of the gases, vapors, or fumes from entering the control device, a deviation occurs when the requirements of paragraph (g)(5)(i) or (ii) of this section are met.

(i) For each bypass line subject to § 60.5411c(a)(4)(i)(A), the flow indicator indicates that flow has been detected and that the stream has been diverted away from the control device to the atmosphere.

(ii) For each bypass line subject to § 60.5411c(a)(4)(i)(B), if the seal or

closure mechanism has been broken, the bypass line valve position has changed, the key for the lock-and-key type lock has been checked out, or the car-seal has broken.

(6) For a combustion control device whose model is tested under § 60.5413c(d), a deviation occurs when the conditions of paragraphs (g)(4), (g)(5), or (g)(6)(i) through (vi) of this section are met.

(i) The hourly inlet gas flow rate is less than the minimum inlet gas flow rate or greater than the maximum inlet gas flow rate determined by the manufacturer. If you use a backpressure regulator valve to maintain the inlet gas flow above the minimum value, a deviation occurs if the annual inspection finds that the backpressure regulator valve set point is not set correctly or indicates that the backpressure regulator valve does not fully close when not in the open position.

(ii) Results of the monthly visible emissions test conducted under § 60.5413c(e)(3) or monitoring under paragraph (h) of this section indicate visible emissions exceed 1 minute in any 15-minute period.

(iii) There is no indication of the presence of a pilot or combustion flame for any 5-minute time period.

(iv) The control device is not maintained in a leak free condition.

(v) The control device is not operated in accordance with the manufacturer's written operating instructions, procedures and maintenance schedule.

(vi) The NHV of the vent gas, the NHV_{cz} , or the NHV_{dil} is below the applicable limit specified in § 60.5412c(a)(1)(iv).

(7) For an enclosed combustion device or flare subject to paragraph (d)(8) of this section, a deviation occurs when any of the conditions described by paragraphs (g)(1), (4), or (5) of this section are met or when the results of the visible emissions monitoring conducted under paragraph (d)(8)(v) or (h) of this section exceed 1 minute in any 15-minute period.

(h) For enclosed combustion devices and flares, in lieu of conducting a visible emissions observation using Method 22 of appendix A-7 to this part, you may use a video surveillance camera to continuously monitor and record the flare flame according to the requirements in paragraphs (h)(1) through (6) of this section.

(1) You must provide real-time high-definition video surveillance camera output (*i.e.*, at least 720p) at a frame rate of at least 15 frames per second to the control room or other continuously manned location where the camera

images may be viewed at the same resolution at any time.

(2) You must record at least one frame every 15 seconds with date and time stamp.

(3) The camera must be located at a reasonable distance above the flare flame at an angle suitable for visual emissions observations. The position of the camera should be such that the sun is not in the field of view.

(4) The camera must be located no more than 400 m (0.25 miles) from the emission source.

(5) Operators must look at the video feed at least once daily for an observation period of at least 1 minute to determine if visible emissions are present. If visible emissions are present during a daily observation, the operator must observe the video feed for 15 minutes or until the amount of time visible emissions is present has exceeded 1 minute, whichever time period is less.

(6) Enclosed combustion devices and flares must be operated with no visible emissions, except for periods not to exceed a total of 1 minute during any 15-minute period.

(i) If you use an enclosed combustion device or flare using an alternative test method approved under § 60.5412c(d), you must comply with paragraphs (i)(1) through (6) of this section.

(1) You must measure data values at the frequency specified in the alternative test method.

(2) You must prepare a monitoring plan that covers each control device for designated facilities within each company-defined area. The monitoring plan must address the monitoring system design, data collection, and the quality assurance and quality control elements outlined in the alternative test method and in paragraphs (i)(2)(i) through (iii) of this section. You must operate and maintain each monitoring system in accordance with the procedures in your monitoring plan.

(i) The performance criteria and design specifications for the monitoring system equipment.

(ii) Location of monitoring system in relation to the monitored control device.

(iii) Ongoing reporting and recordkeeping procedures.

(3) You must conduct the quality assurance and quality control requirements outlined in the alternative test method at the frequency outlined in the alternative test method.

(4) If required by § 60.5412c(d)(4), you must conduct the inspections required by paragraph (d)(8)(v) of this section.

(5) If required by § 60.5412c(d)(5), you must install the pilot or combustion

flame monitoring system required by paragraph (d)(8)(i) of this section.

(6) A deviation for the control device is determined to have occurred when the monitoring data or lack of monitoring data result in any one of the criteria specified in paragraphs (i)(6)(i) through (v) of this section being met.

(i) A deviation occurs if the combustion efficiency is less than 95.0 percent, the combustion zone NHV is less than 270 Btu/scf, or the NHV dilution parameter is less than 22 Btu/sqft.

(ii) A deviation occurs when the monitoring data are not available for at least 75 percent of the operating hours in a day.

(iii) A deviation occurs when any of the conditions described by paragraph (g)(5) of this section are met.

(iv) If required by paragraph (i)(4) of this section to conduct visible emissions inspections, a deviation occurs when the results of the visible emissions monitoring conducted under paragraph (d)(8)(v) or (h) of this section exceeds 1 minute in any 15-minute period.

(v) If required by paragraph (i)(5) of this section to install a pilot or combustion flame monitoring system, a deviation occurs when there is no indication of the presence of a pilot or combustion flame for any 5-minute period.

(j) You must submit annual reports for control devices as required in § 60.5420c(b)(1) and (10). You must maintain records as specified in § 60.5420c(c)(10).

Model Rule—Recordkeeping and Reporting

§ 60.5420c What are my notification, reporting, and recordkeeping requirements?

(a) *Notifications.* You must submit notifications according to paragraphs (a)(1) and (2) of this section if you own or operate one or more of the designated facilities specified in § 60.5386c for which you commenced construction, modification, or reconstruction on or before December 6, 2022. You must submit the notification in paragraph (a)(4) of this section if you undertake well closure activities as specified in § 60.5397c(l).

(1) *Notification of Compliance Report.* For each designated facility subject to the requirements specified under this subpart, an owner or operator is required to submit a statement of compliance with the applicable requirements of this subpart on or before 60 days after the state plan compliance date. Where a designated facility's compliance status is consistent with what was specified in the final

compliance plan increment of progress report, the notification of compliance report would include a statement indicating that compliance is consistent with what was specified in the designated facility's final compliance plan. Where a designated facility's compliance status differs from what was specified in the final compliance plan increment of progress report, the notification of compliance report would indicate how the designated facility's status differs from what was stated in the final compliance plan.

(2) *Notifications.* If you own or operate a process unit equipment designated facility located at an onshore natural gas processing plant, you must submit the notifications required in §§ 60.7(a)(1), (3), and (4) and 60.15(d). If you own or operate a well, centrifugal compressor, reciprocating compressor, process controller, pump, storage vessel, collection of fugitive emissions components at a well site, or collection of fugitive emissions components at a compressor station designated facility, you are not required to submit the notifications required in §§ 60.7(a)(1), (3), and (4) and 60.15(d).

(3) *Notification to Administrator.* An owner or operator who commences well closure activities must submit the following notices to the Administrator according to the schedule in paragraph (a)(4)(i) and (ii) of this section. The notification shall include contact information for the owner or operator; the United States Well Number; the latitude and longitude coordinates for each well at the well site in decimal degrees to an accuracy and precision of five (5) decimals of a degree using the North American Datum of 1983. You must submit notifications in portable document format (PDF) following the procedures specified in paragraph (d) of this section.

(i) You must submit a well closure plan to the Administrator within 30 days of the cessation of production from all wells located at the well site.

(ii) You must submit a notification of the intent to close a well site 60 days before you begin well closure activities.

(b) *Reporting requirements.* You must submit annual reports containing the information specified in paragraphs (b)(1) through (13) of this section following the procedure specified in paragraph (b)(14) of this section. You must submit performance test reports as specified in paragraph (b)(11) or (12) of this section, if applicable. The initial annual report is due no later than 90 days after the end of the initial compliance period as determined according to § 60.5410c. Subsequent annual reports are due no later than the

same date each year as the initial annual report. If you own or operate more than one designated facility, you may submit one report for multiple designated facilities provided the report contains all of the information required as specified in paragraphs (b)(1) through (13) of this section. Annual reports may coincide with title V reports as long as all the required elements of the annual report are included. You may arrange with the Administrator a common schedule on which reports required by this part may be submitted as long as the schedule does not extend the reporting period. You must submit the information in paragraph (b)(1)(v) of this section, as applicable, for your well designated facility which undergoes a change of ownership during the reporting period, regardless of whether reporting under (b)(2) through (3) of this section is required for the well designated facility.

(1) The general information specified in paragraphs (b)(1)(i) through (v) of this section is required for all reports.

(i) The company name, facility site name associated with the designated facility, U.S. Well ID or U.S. Well ID associated with the designated facility, if applicable, and address of the designated facility. If an address is not available for the site, include a description of the site location and provide the latitude and longitude coordinates of the site in decimal degrees to an accuracy and precision of five (5) decimals of a degree using the North American Datum of 1983.

(ii) An identification of each designated facility being included in the annual report.

(iii) Beginning and ending dates of the reporting period.

(iv) A certification by a certifying official of truth, accuracy, and completeness. This certification shall state that, based on information and belief formed after reasonable inquiry, the statements and information in the document are true, accurate, and complete. If your report is submitted via CEDRI, the certifier's electronic signature during the submission process replaces the requirement in this paragraph (b)(1)(iv).

(v) Identification of each well designated facility for which ownership changed due to sale or transfer of ownership including the United States Well Number; the latitude and longitude coordinates of the well designated facility in decimal degrees to an accuracy and precision of five (5) decimals of a degree using the North American Datum of 1983; and the information in paragraph (b)(1)(v)(A) or (B) of this section, as applicable.

(A) The name and contact information, including the phone number, email address, and mailing address, of the owner or operator to which you sold or transferred ownership of the well designated facility identified in paragraph (b)(1)(v) of this section.

(B) The name and contact information, including the phone number, email address, and mailing address, of the owner or operator from whom you acquired the well designated facility identified in paragraph (b)(1)(v) of this section.

(2) For each well designated facility that is subject to § 60.5390c(a)(1) or (2), your annual report is required to include the information specified in paragraphs (b)(2)(i) and (ii) of this section, as applicable.

(i) For each well designated facility where all gas well liquids unloading operations comply with § 60.5390c(a)(1), your annual report must include the information specified in paragraphs (b)(2)(i)(A) through (C) of this section, as applicable.

(A) Identification of each well designated facility (U.S. Well ID or U.S. Well ID associated with the well designated facility) that conducts a gas well liquid unloading operation during the reporting period using a method that does not vent to the atmosphere and the technology or technique used. If more than one non-venting technology or technique is used, you must identify all of the differing non-venting liquids unloading methods used during the reporting period.

(B) Number of gas well liquids unloading operations conducted during the year where the well designated facility identified in (b)(2)(i)(A) had unplanned venting to the atmosphere and best management practices were conducted according to your best management practice plan, as required by § 60.5390c(c). If no venting events occurred, the number would be zero. Other reported information required to be submitted where unplanned venting occurs is specified in paragraphs (b)(2)(i)(B)(1) and (2) of this section.

(1) Log of best management practice plan steps used during the unplanned venting to minimize emissions to the maximum extent possible.

(2) The number of liquids unloading events during the year where deviations from your best management practice plan occurred, the date and time the deviation began, the duration of the deviation in hours, documentation of why best management practice plan steps were not followed, and what steps, in lieu of your best management practice plan steps, were followed to

minimize emissions to the maximum extent possible.

(C) The number of liquids unloading events where unplanned emissions are vented to the atmosphere during a gas well liquids unloading operation where you complied with best management practices to minimize emissions to the maximum extent possible.

(ii) For each well designated facility where all gas well liquids unloading operations comply with § 60.5390c(b) and (c) best management practices, your annual report must include the information specified in paragraphs (b)(2)(ii)(A) through (E) of this section.

(A) Identification of each well designated facility that conducts a gas well liquids unloading during the reporting period.

(B) Number of liquids unloading events conducted during the reporting period.

(C) Log of best management practice plan steps used during the reporting period to minimize emissions to the maximum extent possible.

(D) The number of liquids unloading events during the year that best management practices were conducted according to your best management practice plan.

(E) The number of liquids unloading events during the year where deviations from your best management practice plan occurred, the date and time the deviation began, the duration of the deviation in hours, documentation of why best management practice plan steps were not followed, and what steps, in lieu of your best management practice plan steps, were followed to minimize emissions to the maximum extent possible.

(3) For each associated gas well at your well designated facility that is subject to § 60.5391c, your annual report is required to include the applicable information specified in paragraphs (b)(3)(i) through (v) of this section, as applicable.

(i) For each associated gas well at your well designated facility that complies with § 60.5391c(a)(1), (2), (3), or (4) your annual report is required to include the information specified in paragraphs (b)(3)(i)(A) and (B) of this section.

(A) An identification of each existing associated gas well that complies with § 60.5391c(a)(1), (2), (3), or (4).

(B) The information specified in paragraphs (b)(3)(i)(B)(1) through (3) of this section for each incident when the associated gas was temporarily routed to a flare or control device in accordance with § 60.5377c(c).

(1) The reason in § 60.5377c(c)(1), (2), (3), or (4) for each incident.

(2) The start date and time of each incident of routing associated gas to the flare or control device, along with the total duration in hours of each incident.

(3) Documentation that all CVS requirements specified in § 60.5411c(a) and (c) and all applicable flare or control device requirements specified in § 60.5412c were met during each period when the associated gas is routed to the flare or control device.

(ii) For all instances where you temporarily vent the associated gas in accordance with § 60.5391c(d), you must report the information specified in paragraphs (b)(3)(ii)(A) through (D) of this section. This information is required to be reported if you are routinely complying with § 60.5391c(a) or § 60.5391c(b) or temporarily complying with § 60.5391c(c). In addition to this information for each incident, you must report the cumulative duration in hours of venting incidents and the cumulative VOC and methane emissions in pounds for all incidents in the calendar year.

(A) The reason in § 60.5377c(d)(1), (2), or (3) for each incident.

(B) The start date and time of each incident of venting the associated gas, along with the total duration in hours of each incident.

(C) The methane emissions in pounds that were emitted during each incident.

(D) The total duration of venting for all incidents in the year, along with the cumulative methane emissions in pounds that were emitted.

(iii) For each associated gas well at your well designated facility that complies with the requirements of § 60.5391c(b) by routing your associated gas to a control device that reduces methane emissions by at least 95.0 percent, your annual report must include the information specified in paragraphs (b)(3)(iii)(A) through (C) of this section, and paragraph (D) or (E) of this section. The information in paragraphs (b)(3)(iii)(A) and (B) of this section is only required in the initial annual report.

(A) Identification of the associated gas well using the control device and the information in paragraphs (b)(10)(v) of this section.

(B) The information specified in paragraphs (b)(10)(i) through (iv) of this section.

(C) Identification of each instance when associated gas was vented and not routed to a control device that reduces methane emissions by at least 95.0 percent in accordance with paragraph (c)(3)(ii) of this section.

(D) For each associated gas well that complies with the requirements of § 60.5391c(b) because it has

demonstrated that annual methane emissions are 40 tons per year or less, provide records of the calculation of annual methane emissions determined in accordance with § 60.5391c(e)(1).

(E) For each associated gas well facility that complies with the requirements of § 60.5391c(c) because it has demonstrated that it is not feasible to comply with § 60.5391c(a)(1), (2), (3), or (4) due to technical reasons, provide each annual demonstration and certification of the technical reason that it is not feasible to comply with § 60.5377c(a)(1), (2), (3), and (4) in accordance with § 60.5377c(b)(2)(i), (ii), and (iii).

(iv) If you comply with an alternative GHG standard under § 60.5398c, in lieu of the information specified in paragraphs (b)(10)(i) and (ii) of this section, you must provide the information specified in § 60.5424c.

(v) For each deviation recorded as specified in paragraph (c)(2)(iii) of this section, the date and time the deviation began, the duration of the deviation in hours, and a description of the deviation. If no deviations occurred during the reporting period, you must include a statement that no deviations occurred during the reporting period.

(4) For each centrifugal compressor equipped with a wet seal (including self-contained wet seal centrifugal compressors) and centrifugal compressor equipped with sour seal oil separator and capture system that is a designated facility, the information specified in paragraphs (b)(4)(i) through (vii) of this section, as applicable. For each centrifugal compressor equipped with a dry seal that is a designated facility, the information specified in paragraphs (b)(4)(i) through (xi) of this section.

(i) An identification of each centrifugal compressor.

(ii) For each deviation that occurred during the reporting period and recorded as specified in paragraph (c)(3) of this section, the date and time the deviation began, the duration of the deviation in hours, and a description of the deviation. If no deviations occurred during the reporting period, you must include a statement that no deviations occurred during the reporting period.

(iii) If complying with § 60.5392c(a)(1) and (2) wet and dry seal centrifugal compressor requirements, the cumulative number of hours of operation since initial startup, since 36 months after the state plan submittal deadline (as specified in § 60.5362c(c)), or since the previous volumetric flow rate measurement, as applicable, which have elapsed prior to conducting your

volumetric flow rate measurement or emissions screening.

(iv) A description of the method used and the results of the volumetric emissions measurement or emissions screening, as applicable.

(v) If required to comply with § 60.5392c(a)(5), the information specified in paragraphs (b)(10)(i) through (iv) of this section.

(vi) If complying with § 60.5392c(a)(4) with a control device, identification of the centrifugal compressor with the control device and the information in paragraph (b)(10)(v) of this section.

(vii) If you comply with an alternative GHG standard under § 60.5398c, in lieu of the information specified in paragraphs (b)(10)(i) and (ii) of this section, you must provide the information specified in § 60.5424c.

(viii) Number and type of seals on delay of repair and explanation for each delay of repair.

(ix) Date of planned shutdown(s) that occurred during the reporting period if there are any seals that have been placed on delay of repair.

(5) For each reciprocating compressor designated facility, the information specified in paragraphs (b)(5)(i) through (vii) of this section, as applicable.

(i) The cumulative number of hours of operation since initial startup, since 36 months after the state plan submittal deadline (as specified in § 60.5362c(c)), since the previous volumetric flow rate measurement, or since the previous reciprocating compressor rod packing replacement, as applicable, which have elapsed prior to conducting your volumetric flow rate measurement or emissions screening. Alternatively, a statement that emissions from the rod packing are being routed to a process or control device through a closed vent system.

(ii) If applicable, for each deviation that occurred during the reporting period and recorded as specified in paragraph (c)(4)(i) of this section, the date and time the deviation began, duration of the deviation in hours and a description of the deviation. If no deviations occurred during the reporting period, you must include a statement that no deviations occurred during the reporting period.

(iii) A description of the method used and the results of the volumetric flow rate measurement or emissions screening, as applicable.

(iv) If complying with § 60.5393c(d), the information in paragraphs (b)(10)(i) through (v) of this section.

(v) Number and type of rod packing replacements/repairs on delay of repair and explanation for each delay of repair.

(vi) Date of planned shutdown(s) that occurred during the reporting period if there are any rod packing replacements/repairs that have been placed on delay of repair.

(vii) If you comply with an alternative GHG standard under § 60.5398c, in lieu of the information specified in paragraphs (b)(10)(i) and (ii) of this section, you must provide the information specified in § 60.5424c.

(6) For each process controller designated facility, the information specified in paragraphs (b)(6)(i) through (iii) of this section in your initial annual report and in subsequent annual reports for each process controller designated facility that is constructed, modified, or reconstructed during the reporting period. Each annual report must contain the information specified in paragraphs (b)(6)(iv) through (x) of this section for each process controller designated facility.

(i) An identification of each existing process controller that is driven by natural gas, as required by § 60.5394c(d), that allows traceability to the records required in paragraph (c)(5)(i) of this section.

(ii) For each process controller in the designated facility complying with § 60.5394c(a), you must report the information specified in paragraphs (b)(6)(ii)(A) and (B) of this section, as applicable.

(A) An identification of each process controller complying with § 60.5394c(a)(1) by routing the emissions to a process.

(B) An identification of each process controller complying with § 60.5394c(a)(1) by using a self-contained natural gas-driven process controller.

(iii) For each process controller designated facility located at a site in Alaska that does not have access to electrical power and that complies with § 60.5394c(b), you must report the information specified in paragraphs (b)(6)(iii)(A), (B), or (C) of this section, as applicable.

(A) For each process controller complying with § 60.5394c(b)(1) process controller bleed rate requirements, you must report the information specified in paragraphs (b)(6)(iii)(A)(1) and (2) of this section.

(1) The identification of process controllers designed and operated to achieve a bleed rate less than or equal to 6 scfh.

(2) Where necessary to meet a functional need, the identification and demonstration of why it is necessary to use a process controller with a natural gas bleed rate greater than 6 scfh.

(B) An identification of each intermittent vent process controller complying with the requirements in paragraph § 60.5394c(b)(2).

(C) An identification of each process controller complying with the requirements in § 60.5394c(b) by routing emissions to a control device in accordance with § 60.5394c(b)(3).

(iv) Identification of each process controller which changes its method of compliance during the reporting period and the applicable information specified in paragraphs (b)(6)(v) through (ix) of this section for the new method of compliance.

(v) For each process controller in the designated facility complying with the requirements of § 60.5394c(a) by routing the emissions to a process, you must report the information specified in paragraphs (b)(10)(i) through (iii) of this section.

(vi) For each process controller in the designated facility complying with the requirements of § 60.5394c(a) by using a self-contained natural gas-driven process controller, you must report the information specified in paragraphs (b)(6)(vi)(A) and (B) of this section.

(A) Dates of each inspection required under § 60.5416c(b); and

(B) Each defect or leak identified during each natural gas-driven-self-contained process controller system inspection, and the date of repair or date of anticipated repair if repair is delayed.

(vii) For each process controller in the designated facility complying with the requirements of § 60.5394c(b)(2), you must report the information specified in paragraphs (b)(6)(vii)(A) and (B) of this section.

(A) Dates and results of the intermittent vent process controller monitoring required by § 60.5394c(b)(2)(ii).

(B) For each instance in which monitoring identifies emissions to the atmosphere from an intermittent vent controller during idle periods, the date of repair or replacement or the date of anticipated repair or replacement if the repair or replacement is delayed, and the date and results of the re-survey after repair or replacement.

(viii) For each process controller designated facility complying with § 60.5394c(b)(3) by routing emissions to a control device, you must report the information specified in paragraph (b)(10) of this section.

(ix) For each deviation that occurred during the reporting period, the date and time the deviation began, the duration of the deviation in hours, and a description of the deviation. If no deviations occurred during the reporting period, you must include a statement

that no deviations occurred during the reporting period.

(x) If you comply with an alternative GHG standard under § 60.5398c, in lieu of the information specified in paragraphs (b)(6)(ii)(B) and (b)(10)(i) and (ii) of this section, you must provide the information specified in § 60.5424c.

(7) For each storage vessel designated facility, the information in paragraphs (b)(7)(i) through (x) of this section.

(i) An identification, including the location, of each existing storage vessel designated facility. The location of the storage vessel designated facility shall be in latitude and longitude coordinates in decimal degrees to an accuracy and precision of five (5) decimals of a degree using the North American Datum of 1983.

(ii) Documentation of the methane emission rate determination according to § 60.5386c(e)(1) for each tank battery that became a designated facility during the reporting period or is returned to service during the reporting period.

(iii) For each deviation that occurred during the reporting period and recorded as specified in paragraph (c)(6)(iii) of this section, the date and time the deviation began, duration of the deviation in hours and a description of the deviation. If no deviations occurred during the reporting period, you must include a statement that no deviations occurred during the reporting period.

(iv) For each storage vessel designated facility complying with § 60.5396c(a)(2) with a control device, report the identification of the storage vessel designated facility with the control device and the information in paragraph (b)(10)(v) of this section.

(v) If you comply with an alternative GHG standard under § 60.5398c, in lieu of the information specified in paragraphs (b)(10)(i) and (ii) of this section, you must provide the information specified in § 60.5424c.

(vi) If required to comply with § 60.5396c(b)(1), the information in paragraphs (b)(10)(i) through (iv) of this section.

(vii) You must identify each storage vessel designated facility that is removed from service during the reporting period as specified in § 60.5396c(c)(1)(ii), including the date the storage vessel designated facility was removed from service. You must identify each storage vessel that that is removed from service from a storage vessel designated facility during the reporting period as specified in § 60.5396c(c)(2)(iii), including identifying the impacted storage vessel designated facility and the date each

storage vessel was removed from service.

(viii) You must identify each storage vessel designated facility or portion of a storage vessel designated facility returned to service during the reporting period as specified in § 60.5396c(c)(4), including the date the storage vessel designated facility or portion of a storage vessel designated facility was returned to service.

(ix) You must identify each storage vessel designated facility that no longer complies with § 60.5396c(a)(3) and instead complies with § 60.5396c(a)(2). You must identify whether the change in the method of compliance was due to fracturing or refracturing or whether the change was due to an increase in the monthly emissions determination. If the change was due to an increase in the monthly emissions determination, you must provide documentation of the emissions rate. You must identify the date that you complied with § 60.5396c(a)(2) and must submit the information in (b)(7)(iii) through (vii) of this section.

(x) You must submit a statement that you are complying with § 60.112b(a)(1) or (2), if applicable, in your initial annual report.

(8) For the fugitive emissions components designated facility, report the information specified in paragraphs (b)(8)(i) through (iv) of this section, as applicable.

(i)(A) Designation of the type of site (*i.e.*, well site, centralized production facility, or compressor station) at which the fugitive emissions components designated facility is located.

(B) For the fugitive emissions components designated facility at a well site or centralized production facility that became a designated facility during the reporting period, you must include the date of the startup of production or the date of the first day of production after modification. For the fugitive emissions components designated facility at a compressor station that became a designated facility during the reporting period, you must include the date of startup or the date of modification.

(C) For the fugitive emissions components designated facility at a well site, you must specify what type of well site it is (*i.e.*, single wellhead only well site, small wellsite, multi-wellhead only well site, or a well site with major production and processing equipment).

(D) For the fugitive emissions components designated facility at a well site where during the reporting period you complete the removal of all major production and processing equipment such that the well site contains only one

or more wellheads, you must include the date of the change to status as a wellhead only well site.

(E) For the fugitive emissions components designated facility at a well site where you previously reported under paragraph (b)(8)(i)(D) of this section the removal of all major production and processing equipment and during the reporting period major production and processing equipment is added back to the well site, the date that the first piece of major production and processing equipment is added back to the well site.

(F) For the fugitive emissions components designated facility at a well site where during the reporting period you undertake well closure requirements, the date of the cessation of production from all wells at the well site, the date you began well closure activities at the well site, and the dates of the notifications submitted in accordance with paragraph (a)(5) of this section.

(ii) For each fugitive emissions monitoring survey performed during the annual reporting period, the information specified in paragraphs (b)(8)(ii)(A) through (G) of this section.

(A) Date of the survey.

(B) Monitoring instrument or, if the survey was conducted by visual, audible, or olfactory methods, notation that AVO was used.

(C) Any deviations from the monitoring plan elements under § 60.5397c(c)(1), (2), and (7), (c)(8)(i), or (d) or a statement that there were no deviations from these elements of the monitoring plan.

(D) Number and type of components for which fugitive emissions were detected.

(E) Number and type of fugitive emissions components that were not repaired as required in § 60.5397c(h).

(F) Number and type of fugitive emission components (including designation as difficult-to-monitor or unsafe-to-monitor, if applicable) on delay of repair and explanation for each delay of repair.

(G) Date of planned shutdown(s) that occurred during the reporting period if there are any components that have been placed on delay of repair.

(iii) For well closure activities which occurred during the reporting period, the information in paragraphs (b)(8)(iii)(A) and (B) of this section.

(A) A status report with dates for the well closure activities schedule developed in the well closure plan. If all steps in the well closure plan are completed in the reporting period, the date that all activities are completed.

(B) If an OGI survey is conducted during the reporting period, the information in paragraphs (b)(8)(iii)(B)(1) through (3) of this section.

(1) Date of the OGI survey.

(2) Monitoring instrument used.

(3) A statement that no fugitive emissions were found, or if fugitive emissions were found, a description of the steps taken to eliminate those emissions, the date of the resurvey, the results of the resurvey, and the date of the final resurvey which detected no emissions.

(iv) If you comply with an alternative GHG standard under § 60.5398c, in lieu of the information specified in paragraphs (b)(10)(i) and (ii) of this section, you must provide the information specified in § 60.5424c.

(9) For each pump designated facility, the information specified in paragraphs (b)(9)(i) through (iv) of this section in your initial annual report. Each annual report must contain the information specified in paragraphs (b)(9)(v) through (ix) of this section for each pump designated facility.

(i) The identification of each of your pumps that are driven by natural gas, as required by § 60.5395c(a) that allows traceability to the records required by paragraph (c)(14)(i) of this section.

(ii) For each pump designated facility for which there is a control device on site but it does not achieve a 95.0 percent emissions reduction, the certification that there is a control device available on site but it does not achieve a 95.0 percent emissions reduction required under § 60.5395c(b)(5). You must also report the emissions reduction percentage the control device is designed to achieve.

(iii) For each pump designated facility for which there is no control device or vapor recovery unit on site, the certification required under § 60.5395c(b)(6) that there is no control device or vapor recovery unit on site.

(iv) For each pump designated facility for which it is technically infeasible to route the emissions to a process or control device, the certification of technical infeasibility required under § 60.5395c(b)(7).

(v) For any pump designated facility which has previously reported as required under paragraphs (b)(9)(i) through (iv) of this section and for which a change in the reported condition has occurred during the reporting period, provide the identification of the pump designated facility and the date that the pump designated facility meets one of the change conditions described in

paragraphs (b)(9)(v)(A) through (C) of this section.

(A) If you install a control device or vapor recovery unit, you must report that a control device or vapor recovery unit has been added to the site and that the pump designated facility now is required to comply with § 60.5395c(b)(1) or (3), as applicable.

(B) If your pump designated facility previously complied with § 60.5395c(b)(1) or (3), as applicable, by routing emissions to a process or a control device and the process or control device is subsequently removed from the site or is no longer available such that there is no ability to route the emissions to a process or control device at the location, or that it is not technically feasible to capture and route the emissions to another control device or process located on site, report that you are no longer complying with the applicable requirements of § 60.5395c(b)(1) or (3) and submit the information provided in paragraphs (b)(9)(v)(B)(1) or (2) of this section.

(1) Certification that there is no control device or vapor recovery unit on site.

(2) Certification of the engineering assessment that it is technically infeasible to capture and route the emissions to another control device or process located on site.

(C) If any pump affected facility or individual natural gas-driven pump changes its method of compliance during the reporting period other than for the reasons specified in paragraphs (b)(9)(v)(A) and (B) of this section, identify the new compliance method for each natural gas-driven pump within the affected facility which changes its method of compliance during the reporting period and provide the applicable information specified in paragraphs (b)(9)(ii) through (iv) and (vi) through (viii) of this section for the new method of compliance.

(vi) For each pump designated facility complying with the requirements of § 60.5395c(a) or (b)(2) by routing the emissions to a process, you must report the information specified in paragraphs (b)(11)(i) through (iv) of this section.

(vii) For each pump designated facility complying with the requirements of § 60.5395c(b)(3) by routing the emissions to a control device, you must report the information required under paragraph (b)(11) of this section.

(viii) For each deviation that occurred during the reporting period, the date and time the deviation began, the duration of the deviation in hours, and a description of the deviation. If no deviations occurred during the reporting

period, you must include a statement that no deviations occurred during the reporting period.

(ix) If you comply with an alternative GHG standard under § 60.5398c, in lieu of the information specified in paragraphs (b)(10)(i) and (ii) of this section, you must provide the information specified in § 60.5424c.

(10) For each well, centrifugal compressor, reciprocating compressor, storage vessel, process controller, pump, or process unit equipment designated facility which uses a closed vent system routed to a control device to meet the emissions reduction standard, you must submit the information in paragraphs (b)(10)(i) through (v) of this section. For each centrifugal compressor, reciprocating compressor, process controller, pump, storage vessel, or process unit equipment which uses a closed vent system to route to a process, you must submit the information in paragraphs (b)(10)(i) through (iv) of this section. For each centrifugal compressor and storage vessel equipped with a cover, you must submit the information in paragraphs (b)(10)(i) and (ii).

(i) Dates of each inspection required under § 60.5416c(a) and (b).

(ii) Each defect or emissions identified during each inspection and the date of repair or the date of anticipated repair if the repair is delayed.

(iii) Date and time of each bypass alarm or each instance the key is checked out if you are subject to the bypass requirements of § 60.5416c(a)(4).

(iv) You must submit the certification signed by the qualified professional engineer or in-house engineer according to § 60.5411c(c) for each closed vent system routing to a control device or process in the reporting year in which the certification is signed.

(v) If you comply with the emissions standard for your well, centrifugal compressor, reciprocating compressor, storage vessel, process controller, pump, or process unit equipment designated facility with a control device, the information in paragraphs (b)(10)(v)(A) through (L) of this section, unless you use an enclosed combustion device or flare using an alternative test method approved under § 60.5412c(d). If you use an enclosed combustion device or flare using an alternative test method approved under § 60.5412c(d), the information in paragraphs (b)(10)(v)(A) through (C) and (L) through (P) of this section.

(A) Identification of the control device.

(B) Make, model, and date of installation of the control device.

(C) Identification of the designated facility controlled by the device.

(D) For each continuous parameter monitoring system used to demonstrate compliance for the control device, a unique continuous parameter monitoring system identifier and the make, model number, and date of last calibration check of the continuous parameter monitoring system.

(E) For each instance where there is a deviation of the control device in accordance with § 60.5417c(g)(1) through (3) or (5) through (7) include the date and time the deviation began, the duration of the deviation in hours, the type of the deviation (e.g., NHV operating limit, lack of pilot or combustion flame, condenser efficiency, bypass line flow, visible emissions), and cause of the deviation.

(F) For each instance where there is a deviation of the continuous parameter monitoring system in accordance with § 60.5417c(g)(4) include the date and time the deviation began, the duration of the deviation in hours, and cause of the deviation.

(G) For each visible emissions test following return to operation from a maintenance or repair activity, the date of the visible emissions test or observation of the video surveillance output, the length of the observation in minutes, and the number of minutes for which visible emissions were present.

(H) If a performance test was conducted on the control device during the reporting period, provide the date the performance test was conducted. Submit the performance test report following the procedures specified in paragraph (b)(11) of this section.

(I) If a demonstration of the NHV of the inlet gas to the enclosed combustion device or flare was conducted during the reporting period in accordance with § 60.5417c(d)(8)(iii), an indication of whether this is a re-evaluation of vent gas NHV and the reason for the re-evaluation; the applicable required minimum vent gas NHV; if twice daily samples of the vent stream were taken, the number of hourly average NHV values that are less than 1.2 times the applicable required minimum NHV; if continuous NHV sampling of the vent stream was conducted, the number of hourly average NHV values that are less than the required minimum vent gas NHV; if continuous combustion efficiency monitoring was conducted using an alternative test method approved under § 60.5412c(d), the number of values of the combustion efficiency that were less than 95.0 percent; the resulting determination of whether NHV monitoring is required or not in accordance with

§ 60.5417c(d)(8)(iii)(D) or (H); and an indication of whether the enclosed combustion device or flare has the potential to receive inert gases, and if so, whether the sampling included periods where the highest percentage of inert gases were sent to the enclosed combustion device or flare.

(J) If a demonstration was conducted in accordance with § 60.5417c(d)(8)(iv) that the maximum potential pressure of units manifolded to an enclosed combustion device or flare cannot cause the maximum inlet flow rate established in accordance with § 60.5417c(f)(1) or a flare tip velocity limit of 18.3 meter/second (60 feet/second) to be exceeded, an indication of whether this is a re-evaluation of the gas flow and the reason for the re-evaluation; the demonstration conducted; and applicable engineering calculations.

(K) For each periodic sampling event conducted under § 60.5417c(d)(8)(iii)(G), provide the date of the sampling, the required minimum vent gas NHV, and the NHV value for each vent gas sample.

(L) For each flare and enclosed combustion device, provide the date each device is observed with OGI in accordance with § 60.5415c(e)(x) and whether uncombusted emissions were present. Provide the date each device was visibly observed during an AVO inspection in accordance with § 60.5415c(e)(x), whether the pilot or combustion flame was lit at the time of observation, and whether the device was found to be operating properly.

(M) An identification of the alternative test method used.

(N) For each instance where there is a deviation of the control device in accordance with § 60.5417c(i)(6)(i) or (iii) through (v) include the date and time the deviation began, the duration of the deviation in hours, the type of the deviation (*e.g.*, NHV_{cz} operating limit, lack of pilot or combustion flame, visible emissions), and cause of the deviation.

(O) For each instance where there is a deviation of the data availability in accordance with § 60.5417c(i)(6)(ii) include the date of each operating day when monitoring data are not available for at least 75 percent of the operating hours.

(P) If no deviations occurred under paragraphs (b)(11)(v)(N) or (O) of this section, a statement that there were no deviations for the control device during the annual report period.

(Q) Any additional information required to be reported as specified by the Administrator as part of the alternative test method approval under § 60.5412c(d).

(11) Within 60 days after the date of completing each performance test (see § 60.8) required by this subpart, except testing conducted by the manufacturer as specified in § 60.5413c(d), you must submit the results of the performance test following the procedures specified in paragraph (d) of this section. Data collected using test methods that are supported by the EPA's Electronic Reporting Tool (ERT) as listed on the EPA's ERT website (<https://www.epa.gov/electronic-reporting-air-emissions/electronic-reporting-tool-ert>) at the time of the test must be submitted in a file format generated using the EPA's ERT. Alternatively, you may submit an electronic file consistent with the extensible markup language (XML) schema listed on the EPA's ERT website. Data collected using test methods that are not supported by the EPA's ERT as listed on the EPA's ERT website at the time of the test must be included as an attachment in the ERT or alternate electronic file.

(12) For combustion control devices tested by the manufacturer in accordance with § 60.5413c(d), an electronic copy of the performance test results required by § 60.5413c(d) shall be submitted via email to Oil_and_Gas_PT@EPA.GOV unless the test results for that model of combustion control device are posted at the following website: <https://www.epa.gov/controlling-air-pollution-oil-and-natural-gas-industry>.

(13) If you had a super-emitter event during the reporting period, the start date of the super-emitter event, the duration of the super-emitter event in hours, and the designated facility associated with the super-emitter event, if applicable.

(14) You must submit your annual report using the appropriate electronic report template on the Compliance and Emissions Data Reporting Interface (CEDRI) website for this subpart and following the procedure specified in paragraph (d) of this section. If the reporting form specific to this subpart is not available on the CEDRI website at the time that the report is due, you must submit the report to the Administrator at the appropriate address listed in § 60.4. Once the form has been available on the CEDRI website for at least 90 calendar days, you must begin submitting all subsequent reports via CEDRI. The date reporting forms become available will be listed on the CEDRI website. Unless the Administrator or delegated state agency or other authority has approved a different schedule for submission of reports, the report must be submitted by the deadline specified in this subpart,

regardless of the method in which the report is submitted.

(c) *Recordkeeping requirements.* You must maintain the records identified as specified in § 60.7(f) and in paragraphs (c)(1) through (14) of this section. All records required by this subpart must be maintained either onsite or at the nearest local field office for at least 5 years. Any records required to be maintained by this subpart that are submitted electronically via the EPA's CEDRI may be maintained in electronic format. This ability to maintain electronic copies does not affect the requirement for facilities to make records, data, and reports available upon request to a delegated air agency or the EPA as part of an on-site compliance evaluation.

(1) For each gas well liquids unloading operation at your well designated facility that is subject to § 60.5390c(a)(1) or (2), the records of each gas well liquids unloading operation conducted during the reporting period, including the information specified in paragraphs (c)(1)(i) through (iii) of this section, as applicable.

(i) For each gas well liquids unloading operation that complies with § 60.5390c(a)(1) by performing all liquids unloading events without venting of methane emissions to the atmosphere, comply with the recordkeeping requirements specified in paragraphs (c)(1)(i)(A) and (B) of this section.

(A) Identification of each well (*i.e.*, U.S. Well ID or U.S. Well ID associated with the well designated facility) that conducts a gas well liquids unloading operation during the reporting period without venting of methane emissions and the non-venting gas well liquids unloading method used. If more than one non-venting method is used, you must maintain records of all the differing non-venting liquids unloading methods used at the well designated facility complying with § 60.5376c(a)(1).

(B) Number of events where unplanned emissions are vented to the atmosphere during a gas well liquids unloading operation where you complied with best management practices to minimize emissions to the maximum extent possible.

(ii) For each gas well liquids unloading operation that complies with § 60.5390c(b) and (c) best management practices, maintain records documenting information specified in paragraphs (c)(1)(ii)(A) through (D) of this section.

(A) Identification of each well designated facility that conducts liquids unloading during the reporting period

that employs best management practices to minimize emissions to the maximum extent possible.

(B) Documentation of your best management practice plan developed under paragraph § 60.5390c(c). You may update your best management practice plan to include additional steps which meet the criteria in § 60.5390c(c).

(C) A log of each best management practice plan step taken minimize emissions to the maximum extent possible for each gas well liquids unloading event.

(D) Documentation of each gas well liquids unloading event where deviations from your best management practice plan steps occurred, the date and time the deviation began, the duration of the deviation, documentation of best management practice plans steps were not followed, and the steps taken in lieu of your best management practice plan steps during those events to minimize emissions to the maximum extent possible.

(iii) For each well designated facility that reduces methane emissions from well designated facility gas wells that unload liquids by 95.0 percent by routing emissions to a control device through closed vent system under § 60.5390c(g), you must maintain the records in paragraphs (c)(1)(iii)(A) through (E) of this section.

(A) If you comply with the emission reduction standard with a control device, the information for each control device in paragraph (c)(10) of this section.

(B) Records of the closed vent system inspection as specified paragraph (c)(7) of this section.

(C) Records of the cover inspections as specified in paragraph (c)(8) of this section.

(D) If applicable, the records of bypass monitoring as specified in paragraph (c)(9) of this section.

(E) Records of the closed vent system assessment as specified in paragraph (c)(11) of this section.

(2) For each associated gas well, you must maintain the applicable records specified in paragraphs (c)(2)(i) or (ii) and (vi) of this section, as applicable.

(i) For each associated gas well that complies with the requirements of § 60.5391c(a)(1), (2), (3), or (4), you must keep the records specified in paragraphs (c)(2)(i)(A) and (B) of this section.

(A) Documentation of the specific method(s) in § 60.5391c(a)(1), (2), (3), or (4) that was used.

(B) For instances where you temporarily route the associated gas to a flare or control device in accordance with § 60.5377c(c), you must keep the

records specified in paragraphs (c)(2)(i)(B)(1) through (3) of this section.

(1) The reason in § 60.5377c(c)(1), (2), (3), or (4) for each incident.

(2) The date of each incident, along with the times when routing the associated gas to the flare or control device started and ended, along with the total duration of each incident.

(3) Documentation that all CVS requirements specified in § 60.5411c(a) and (c) and all applicable flare or control device requirements specified in § 60.5412c are met during each period when the associated gas is routed to the flare or control device.

(ii) For instances where you temporarily vent the associated gas in accordance with § 60.5377c(d), you must keep the records specified in paragraphs (c)(2)(ii)(A) through (D) of this section. These records are required if you are routinely complying with § 60.5391c(a) or § 60.5391c(b) or temporarily complying with § 60.5391c(c).

(A) The reason in § 60.5391c(d)(1), (2), or (3) for each incident.

(B) The date of each incident, along with the times when venting the associated gas started and ended, along with the total duration of each incident.

(C) The methane emissions that were emitted during each incident.

(D) The cumulative duration of venting incidents and methane emissions for all incidents in each calendar year.

(iii) For each associated gas well that complies with the requirements of § 60.5391c(b) because it has demonstrated that annual methane emissions are 40 tons per year or less at the initial compliance date, maintain records of the calculation of annual methane emissions determined in accordance with § 60.5391c(e)(1).

(iv) For each associated gas well at your well that complies with the requirements of § 60.5391c(b) because it has demonstrated that it is not feasible to comply with § 60.5391c(a)(1), (2), (3), or (4) due to technical reasons, records of each annual demonstration and certification of the technical reason that it is not feasible to comply with § 60.5377c(a)(1), (2), (3), and (4) in accordance with § 60.5377c(b)(2)(i), (ii), and (iii), as well as the records required by paragraph (c)(2)(v) of this section.

(v) For each associated gas well that complies with the requirements of § 60.5391c(b) by routing your associated gas to a flare or control device that achieves a 95.0 reduction in methane emissions, the records in paragraphs (c)(2)(v)(A) through (E) of this section.

(A) Identification of each instance when associated gas was vented and not

routed to a control device that reduces methane emissions by at least 95.0 percent in accordance with paragraph (c)(2)(iii) of this section.

(B) If you comply with the emission reduction standard in § 60.5392c with a control device, the information for each control device in paragraph (c)(10) of this section.

(C) Records of the closed vent system inspection as specified paragraph (c)(7) of this section. If you comply with an alternative GHG standard under § 60.5398c, in lieu of the information specified in paragraphs (c)(7) of this section, you must maintain records of the information specified in § 60.5424c.

(D) If applicable, the records of bypass monitoring as specified in paragraph (c)(9) of this section.

(E) Records of the closed vent system assessment as specified in paragraph (c)(11) of this section.

(vi) Records of each deviation, the date and time the deviation began, the duration of the deviation, and a description of the deviation.

(3) For each centrifugal compressor designated facility, you must maintain the records specified in paragraphs (c)(3)(i) through (iii) of this section.

(i) For each centrifugal compressor designated facility, you must maintain records of deviations in cases where the centrifugal compressor was not operated in compliance with the requirements specified in § 60.5392c, including a description of each deviation, the date and time each deviation began and the duration of each deviation.

(ii) For each wet seal compressor complying with the emissions reduction standard in § 60.5392c(a)(3) and (4), you must maintain the records in paragraphs (c)(3)(ii)(A) through (F) of this section. For each wet seal compressor complying with the alternative standard in § 60.5392c(a)(3) and (5) by routing the closed vent system to a process, you must maintain the records in paragraphs (c)(3)(ii)(C) through (E) of this section.

(A) If you comply with the emission reduction standard in with a control device, the information for each control device in paragraph (c)(10) of this section.

(B) Records of the closed vent system inspection as specified paragraph (c)(7) of this section. If you comply with an alternative GHG standard under § 60.5398c, in lieu of the information specified in paragraphs (c)(7) of this section, you must maintain records of the information specified in § 60.5424c.

(C) Records of the cover inspections as specified in paragraph (c)(8) of this section. If you comply with an alternative GHG standard under § 60.5398c, in lieu of the information

specified in paragraph (c)(8) of this section, you must maintain the information specified in § 60.5424c.

(D) If applicable, the records of bypass monitoring as specified in paragraph (c)(9) of this section.

(E) Records of the closed vent system assessment as specified in paragraph (c)(11) of this section.

(iii) For each centrifugal compressor designated facility using dry seals or wet seals and each self-contained wet seal centrifugal compressor and complying with the standard in § 60.5392c(a)(1) and (2), you must maintain the records specified in paragraphs (c)(3)(iii)(A) through (H) of this section.

(A) Records of the cumulative number of hours of operation since initial startup, since 36 months after the state plan submittal deadline (as specified in § 60.5362c(c)), or since the previous volumetric flow rate measurement, as applicable.

(B) A description of the method used and the results of the volumetric flow rate measurement or emissions screening, as applicable.

(C) Records for all flow meters, composition analyzers and pressure gauges used to measure volumetric flow rates as specified in paragraphs (c)(3)(iii)(C)(1) through (7) of this section.

(1) Description of standard method published by a consensus-based standards organization or industry standard practice.

(2) Records of volumetric flow rate emissions calculations conducted according to § 60.5392c(a)(2), as applicable.

(3) Records of manufacturer operating procedures and measurement methods.

(4) Records of manufacturer's recommended procedures or an appropriate industry consensus standard method for calibration and results of calibration, recalibration and accuracy checks.

(5) Records which demonstrate that measurements at the remote location(s) can, when appropriate correction factors are applied, reliably and accurately represent the actual temperature or total pressure at the flow meter under all expected ambient conditions. You must include the date of the demonstration, the data from the demonstration, the mathematical correlation(s) between the remote readings and actual flow meter conditions derived from the data, and any supporting engineering calculations. If adjustments were made to the mathematical relationships, a record and description of such adjustments.

(6) Record of each initial calibration or a recalibration which failed to meet the required accuracy specification and the date of the successful recalibration.

(D) Date when performance-based volumetric flow rate is exceeded.

(E) The date of successful repair of the compressor seal, including follow-up performance-based volumetric flow rate measurement to confirm successful repair.

(F) Identification of each compressor seal placed on delay of repair and explanation for each delay of repair.

(G) For each compressor seal or part needed for repair placed on delay of repair because of replacement seal or part unavailability, the operator must document: the date the seal or part was added to the delay of repair list, the date the replacement seal or part was ordered, the anticipated seal or part delivery date (including any estimated shipment or delivery date provided by the vendor), and the actual arrival date of the seal or part.

(H) Date of planned shutdowns that occur while there are any seals or parts that have been placed on delay of repair.

(4) For each reciprocating compressor designated facility, you must maintain the records in paragraphs (c)(4)(i) through (vi), (7), (9) and (11) of this section, as applicable. If you comply with an alternative GHG standard under § 60.5398c, in lieu of the information specified in paragraph (c)(7) of this section, you must provide the information specified in § 60.5424c.

(i) For each reciprocating compressor designated facility, you must maintain records of deviations in cases where the reciprocating compressor was not operated in compliance with the requirements specified in § 60.5393c, including a description of each deviation, the date and time each deviation began and the duration of each deviation in hours.

(ii) Records of the date of installation of a rod packing emissions collection system and closed vent system as specified in § 60.5393c(d).

(iii) Records of the cumulative number of hours of operation since initial startup, since 36 months after the state plan submittal deadline (as specified in § 60.5362c(c)), or since the previous volumetric flow rate measurement, as applicable. Alternatively, a record that emissions from the rod packing are being routed to a process through a closed vent system.

(iv) A description of the method used and the results of the volumetric flow rate measurement or emissions screening, as applicable.

(v) Records for all flow meters, composition analyzers and pressure

gauges used to measure volumetric flow rates as specified in paragraphs (c)(4)(v)(A) through (F) of this section.

(A) Description of standard method published by a consensus-based standards organization or industry standard practice.

(B) Records of volumetric flow rate calculations conducted according to paragraphs § 60.5393c(b) or (c), as applicable.

(C) Records of manufacturer's operating procedures and measurement methods.

(D) Records of manufacturer's recommended procedures or an appropriate industry consensus standard method for calibration and results of calibration, recalibration and accuracy checks.

(E) Records which demonstrate that measurements at the remote location(s) can, when appropriate correction factors are applied, reliably and accurately represent the actual temperature or total pressure at the flow meter under all expected ambient conditions. You must include the date of the demonstration, the data from the demonstration, the mathematical correlation(s) between the remote readings and actual flow meter conditions derived from the data, and any supporting engineering calculations. If adjustments were made to the mathematical relationships, a record and description of such adjustments.

(F) Record of each initial calibration or a recalibration which failed to meet the required accuracy specification and the date of the successful recalibration.

(vi) Date when performance-based volumetric flow rate is exceeded.

(vii) The date of successful replacement or repair of reciprocating compressor rod packing, including follow-up performance-based volumetric flow rate measurement to confirm successful repair.

(viii) Identification of each reciprocating compressor placed on delay of repair because of rod packing or part unavailability and explanation for each delay of repair.

(ix) For each reciprocating compressor that is placed on delay of repair because of replacement rod packing or part unavailability, the operator must document: the date the rod packing or part was added to the delay of repair list, the date the replacement rod packing or part was ordered, the anticipated rod packing or part delivery date (including any estimated shipment or delivery date provided by the vendor), and the actual arrival date of the rod packing or part.

(x) Date of planned shutdowns that occur while there are any reciprocating

compressors that have been placed on delay of repair due to the unavailability of rod packing or parts to conduct repairs.

(5) For each process controller designated facility, you must maintain the records specified in paragraphs (c)(5)(i) through (vii) of this section.

(i) Records identifying each process controller that is driven by natural gas and that does not function as an emergency shutdown device.

(ii) For each process controller designated facility complying with § 60.5394c(a), you must maintain records of the information specified in paragraphs (c)(5)(ii)(A) and (B) of this section, as applicable.

(A) If you are complying with § 60.5390c(a) by routing process controller vapors to a process through a closed vent system, you must report the information specified in paragraphs (c)(5)(ii)(A)(1) and (2) of this section.

(1) An identification of all the natural gas-driven process controllers in the process controller designated facility for which you collect and route vapors to a process through a closed vent system.

(2) The records specified in paragraphs (c)(7), (9), and (11) of this section. If you comply with an alternative GHG standard under § 60.5398c, in lieu of the information specified in paragraph (c)(7) of this section, you must provide the information specified in § 60.5424c.

(B) If you are complying with § 60.5394c(a) by using a self-contained natural gas-driven process controller, you must report the information specified in paragraphs (c)(5)(ii)(B)(1) through (3) of this section.

(1) An identification of each process controller complying with § 60.5394c(a) by using a self-contained natural gas-driven process controller;

(2) Dates of each inspection required under § 60.5416c(b); and

(3) Each defect or leak identified during each natural gas-driven-self-contained process controller system inspection, and date of repair or date of anticipated repair if repair is delayed.

(iii) For each process controller designated facility complying with § 60.5394c(b)(1) process controller bleed rate requirements, you must maintain records of the information specified in paragraphs (c)(5)(iii)(A) and (B) of this section.

(A) The identification of process controllers designed and operated to achieve a bleed rate less than or equal to 6 scfh and records of the manufacturer's specifications indicating that the process controller is designed with a natural gas bleed rate of less than or equal to 6 scfh.

(B) Where necessary to meet a functional need, the identification of the process controller and demonstration of why it is necessary to use a process controller with a natural gas bleed rate greater than 6 scfh.

(iv) For each intermittent vent process controller in the designated facility complying with the requirements in § 60.5394c(b)(2), you must keep records of the information specified in paragraphs (c)(5)(iv)(A) through (C) of this section.

(A) The identification of each intermittent vent process controller.

(B) Dates and results of the intermittent vent process controller monitoring required by § 60.5394c(b)(2)(ii).

(C) For each instance in which monitoring identifies emissions to the atmosphere from an intermittent vent controller during idle periods, the date of repair or replacement, or the date of anticipated repair or replacement if the repair or replacement is delayed and the date and results of the re-survey after repair or replacement.

(v) For each process controller designated facility complying with § 60.5394c(b)(3), you must maintain the records specified in paragraphs (c)(5)(v)(A) and (B) of this section.

(A) An identification of each process controller for which emissions are routed to a control device.

(B) Records specified in paragraphs (c)(7) and (9) through (12) of this section. If you comply with an alternative GHG standard under § 60.5398c, in lieu of the information specified in paragraphs (c)(7) of this section, you must provide the information specified in § 60.5424c.

(vi) Records of each change in compliance method, including identification of each natural gas-driven process controller which changes its method of compliance, the new method of compliance, and the date of the change in compliance method.

(vii) Records of each deviation, the date and time the deviation began, the duration of the deviation, and a description of the deviation.

(6) For each storage vessel designated facility, you must maintain the records identified in paragraphs (c)(6)(i) through (vii) of this section.

(i) You must maintain records of the identification and location in latitude and longitude coordinates in decimal degrees to an accuracy and precision of five (5) decimals of a degree using the North American Datum of 1983 of each storage vessel designated facility.

(ii) Records of each methane emissions determination for each storage vessel designated facility made

under § 60.5396c(e) including identification of the model or calculation methodology used to calculate the methane emission rate.

(iii) For each instance where the storage vessel was not operated in compliance with the requirements specified in § 60.5396c, a description of the deviation, the date and time each deviation began, and the duration of the deviation.

(iv) If complying with the emissions reduction standard in § 60.5396c(a)(1), you must maintain the records in paragraphs (c)(6)(iv)(A) through (E) of this section.

(A) If you comply with the emission reduction standard with a control device, the information for each control device in paragraph (c)(10) of this section.

(B) Records of the closed vent system inspection as specified paragraph (c)(7) of this section. If you comply with an alternative GHG standard under § 60.5398c, in lieu of the information specified in paragraph (c)(7) of this section, you must provide the information specified in § 60.5424c.

(C) Records of the cover inspections as specified in paragraph (c)(8) of this section. If you comply with an alternative GHG standard under § 60.5398c, in lieu of the information specified in paragraph (c)(8) of this section, you must provide the information specified in § 60.5424c.

(D) If applicable, the records of bypass monitoring as specified in paragraph (c)(9) of this section.

(E) Records of the closed vent system assessment as specified in paragraph (c)(11) of this section.

(v) For storage vessels that are skid-mounted or permanently attached to something that is mobile (such as trucks, railcars, barges, or ships), records indicating the number of consecutive days that the vessel is located at a site in the crude oil and natural gas source category. If a storage vessel is removed from a site and, within 30 days, is either returned to the site or replaced by another storage vessel at the site to serve the same or similar function, then the entire period since the original storage vessel was first located at the site, including the days when the storage vessel was removed, will be added to the count towards the number of consecutive days.

(vi) Records of the date that each storage vessel designated facility or portion of a storage vessel designated facility is removed from service and returned to service, as applicable.

(vii) Records of the date that liquids from the well following fracturing or refracturing are routed to the storage

vessel designated facility; or the date that you comply with paragraph § 60.5396c(a)(2), following a monthly emissions determination which indicates that methane emissions increase to 14 tpy or greater and the increase is not associated with fracturing or refracturing of a well feeding the storage vessel designated facility, and records of the methane emissions rate and the model or calculation methodology used to calculate the methane emission rate.

(7) Records of each closed vent system inspection required under § 60.5416c(a)(1) and (2) and (b) for your well, centrifugal compressor, reciprocating compressor, process controller, pump, storage vessel, and process unit equipment designated facility as required in paragraphs (c)(7)(i) through (iv) of this section.

(i) A record of each closed vent system inspection or no identifiable emissions monitoring survey. You must include an identification number for each closed vent system (or other unique identification description selected by you), the date of the inspection, and the method used to conduct the inspection (*i.e.*, visual, AVO, OGI, Method 21 of appendix A–7 to this part).

(ii) For each defect or emissions detected during inspections required by § 60.5416c(a)(1) and (2), or (b) you must record the location of the defect or emissions; a description of the defect; the maximum concentration reading obtained if using Method 21 of appendix A–7 to this part; the indication of emissions detected by AVO if using AVO; the date of detection; the date of each attempt to repair the emissions or defect; the corrective action taken during each attempt to repair the defect; and the date the repair to correct the defect or emissions is completed.

(iii) If repair of the defect is delayed as described in § 60.5416c(b)(6), you must record the reason for the delay and the date you expect to complete the repair.

(iv) Parts of the closed vent system designated as unsafe to inspect as described in § 60.5416c(b)(7) or difficult to inspect as described in § 60.5416c(b)(8), the reason for the designation, and written plan for inspection of that part of the closed vent system.

(8) A record of each cover inspection required under § 60.5416c(a)(3) for your centrifugal compressor, reciprocating compressor, or storage vessel as required in paragraphs (c)(8)(i) through (iv) of this section.

(i) A record of each cover inspection. You must include an identification number for each cover (or other unique identification description selected by you), the date of the inspection, and the method used to conduct the inspection (*i.e.*, AVO, OGI, Method 21 of appendix A–7 to this part).

(ii) For each defect detected during the inspection you must record the location of the defect; a description of the defect; the date of detection; the maximum concentration reading obtained if using Method 21 of appendix A–7 to this part; the indication of emissions detected by AVO if using AVO; the date of each attempt to repair the defect; the corrective action taken during each attempt to repair the defect; and the date the repair to correct the defect is completed.

(iii) If repair of the defect is delayed as described in § 60.5416c(b)(5), you must record the reason for the delay and the date you expect to complete the repair.

(iv) Parts of the cover designated as unsafe to inspect as described in § 60.5416c(b)(7) or difficult to inspect as described in § 60.5416c(b)(8), the reason for the designation, and written plan for inspection of that part of the cover.

(9) For each bypass subject to the bypass requirements of § 60.5416c(a)(4), you must maintain a record of the following, as applicable: readings from the flow indicator; each inspection of the seal or closure mechanism; the date and time of each instance the key is checked out; date and time of each instance the alarm is sounded.

(10) Records for each control device used to comply with the emission reduction standard in § 60.5391c(b) for associated gas wells, § 60.5392c(a)(4) for centrifugal compressor designated facilities, § 60.5393c(d)(2) for reciprocating compressor designated facilities, § 60.5394c(b)(3) for your process controller designated facility in Alaska, § 60.5395c(b)(1) for your pump designated facility, § 60.5396c(a)(2) for your storage vessel designated facility, § 60.5390c(f) for well designated facility gas well liquids unloading, or § 60.5400c(f) or 60.5401c(e) for your process equipment designated facility, as required in paragraphs (c)(10)(i) through (viii) of this section. If you use an enclosed combustion device or flare using an alternative test method approved under § 60.5412c(d), keep records of the information in paragraphs (c)(10)(ix) of this section, in lieu of the records required by paragraphs (c)(10)(i) through (iv) and (vi) through (viii) of this section.

(i) For a control device tested under § 60.5413c(d) which meets the criteria in § 60.5413c(d)(11) and (e), keep records of the information in paragraphs (c)(10)(i)(A) through (E) of this section, in addition to the records in paragraphs (c)(10)(ii) through (ix) of this section, as applicable.

(A) Serial number of purchased device and copy of purchase order.

(B) Location of the designated facility associated with the control device in latitude and longitude coordinates in decimal degrees to an accuracy and precision of five (5) decimals of a degree using the North American Datum of 1983.

(C) Minimum and maximum inlet gas flow rate specified by the manufacturer.

(D) Records of the maintenance and repair log as specified in § 60.5413c(e)(4), for all inspection, repair, and maintenance activities for each control device failing the visible emissions test.

(E) Records of the manufacturer's written operating instructions, procedures, and maintenance schedule to ensure good air pollution control practices for minimizing emissions.

(ii) For all control devices, keep records of the information in paragraphs (c)(10)(ii)(A) through (G) of this section, as applicable.

(A) Make, model, and date of installation of the control device, and identification of the designated facility controlled by the device.

(B) Records of deviations in accordance with § 60.5417c(g)(1) through (7), including a description of the deviation, the date and time the deviation began, the duration of the deviation, and the cause of the deviation.

(C) The monitoring plan required by § 60.5417c(c)(2).

(D) Make and model number of each continuous parameter monitoring system.

(E) Records of minimum and maximum operating parameter values, continuous parameter monitoring system data (including records that the pilot or combustion flame is present at all times), calculated averages of continuous parameter monitoring system data, and results of all compliance calculations.

(F) Records of continuous parameter monitoring system equipment performance checks, system accuracy audits, performance evaluations, or other audit procedures and results of all inspections specified in the monitoring plan in accordance with § 60.5417c(c)(2). Records of calibration gas cylinders, if applicable.

(G) Periods of monitoring system malfunctions, repairs associated with monitoring system malfunctions and required monitoring system quality assurance or quality control activities. Records of repairs on the monitoring system.

(iii) For each carbon adsorption system, records of the schedule for carbon replacement as determined by the design analysis requirements of § 60.5413c(c)(2) and (3) and records of each carbon replacement as specified in § 60.5412c(c)(1) and § 60.5415c(e)(1)(viii).

(iv) For enclosed combustion devices and flares, records of visible emissions observations as specified in paragraph (c)(10)(iv)(A) or (B) of this section.

(A) Records of observations with Method 22 of appendix A-7 to this part, including observations required following return to operation from a maintenance or repair activity, which include: company, location, company representative (name of the person performing the observation), sky conditions, process unit (type of control device), clock start time, observation period duration (in minutes and seconds), accumulated emission time (in minutes and seconds), and clock end time. You may create your own form including the above information or use Figure 22-1 in Method 22 of appendix A-7 to this part.

(B) If you monitor visible emissions with a video surveillance camera, location of the camera and distance to emission source, records of the video surveillance output, and documentation that an operator looked at the feed daily, including the date and start time of observation, the length of observation, and length of time visible emissions were present.

(v) For enclosed combustion devices and flares, video of the OGI inspection conducted in accordance with § 60.5415c(e)(x). Records documenting each enclosed combustion device and flare was visibly observed during each inspection conducted under § 60.5397c using AVO in accordance with § 60.5415c(e)(x).

(vi) For enclosed combustion devices and flares, records of each demonstration of the NHV of the inlet gas to the enclosed combustion device or flare conducted in accordance with § 60.5417c(d)(8)(iii). For each re-evaluation of the NHV of the inlet gas, records of process changes and explanation of the conditions that led to the need to re-evaluation the NHV of the inlet gas. For each demonstration, record information on whether the enclosed combustion device or flare has the potential to receive inert gases, and

if so, the highest percentage of inert gases that can be sent to the enclosed combustion device or flare and the highest percent of inert gases sent to the enclosed combustion device or flare during the NHV demonstration. Records of periodic sampling conducted under § 60.5417c(d)(8)(iii)(G).

(vii) For enclosed combustion devices and flares, if you use a backpressure regulator valve, the make and model of the valve, date of installation, and record of inlet flow rating. Maintain records of the engineering evaluation and manufacturer specifications that identify the pressure set point corresponding to the minimum inlet gas flow rate, the annual confirmation that the backpressure regulator valve set point is correct and consistent with the engineering evaluation and manufacturer specifications, and the annual confirmation that the backpressure regulator valve fully closes when not in open position.

(viii) For enclosed combustion devices and flares, records of each demonstration required under § 60.5417c(d)(8)(iv).

(ix) If you use an enclosed combustion device or flare using an alternative test method approved under § 60.5412c(d), keep records of the information in paragraphs (c)(10)(ix)(A) through (H) of this section, in lieu of the records required by paragraphs (c)(10)(i) through (iv) and (vi) through (viii) of this section.

(A) An identification of the alternative test method used.

(B) Data recorded at the intervals required by the alternative test method.

(C) Monitoring plan required by § 60.5417c(i)(2).

(D) Quality assurance and quality control activities conducted in accordance with the alternative test method.

(E) If required by § 60.5412c(d)(4) to conduct visible emissions observations, records required by paragraph (c)(10)(iv) of this section.

(F) If required by § 60.5412c(d)(5) to conduct pilot or combustion flame monitoring, record indicating the presence of a pilot or combustion flame and periods when the pilot or combustion flame is absent.

(G) For each instance where there is a deviation of the control device in accordance with § 60.5417c(i)(6)(i) through (v), the date and time the deviation began, the duration of the deviation in hours, and cause of the deviation.

(H) Any additional information required to be recorded as specified by the Administrator as part of the

alternative test method approval under § 60.5412c(d).

(11) For each closed vent system routing to a control device or process, the records of the assessment conducted according to § 60.5411c(c):

(i) A copy of the assessment conducted according to § 60.5411c(c)(1); and

(ii) A copy of the certification according to § 60.5411c(c)(1)(i) and (ii).

(12) A copy of each performance test submitted under paragraphs (b)(11) or (12) of this section.

(13) For the fugitive emissions components designated facility, maintain the records identified in paragraphs (c)(13)(i) through (vii) of this section.

(i) The date of the startup of production or the date of the first day of production after modification for the fugitive emissions components designated facility at a well site and the date of startup or the date of modification for the fugitive emissions components designated facility at a compressor station.

(ii) For the fugitive emissions components designated facility at a well site, you must maintain records specifying what type of well site it is (*i.e.*, single wellhead only well site, small wellsite, multi-wellhead only well site, or a well site with major production and processing equipment.)

(iii) For the fugitive emissions components designated facility at a well site where you complete the removal of all major production and processing equipment such that the well site contains only one or more wellheads, record the date the well site completes the removal of all major production and processing equipment from the well site, and, if the well site is still producing, record the well ID or separate tank battery ID receiving the production from the well site. If major production and processing equipment is subsequently added back to the well site, record the date that the first piece of major production and processing equipment is added back to the well site.

(iv) The fugitive emissions monitoring plan as required in § 60.5397c(b), (c), and (d).

(v) The records of each monitoring survey as specified in paragraphs (c)(13)(v)(A) through (I) of this section.

(A) Date of the survey.

(B) Beginning and end time of the survey.

(C) Name of operator(s), training, and experience of the operator(s) performing the survey.

(D) Monitoring instrument or method used.

(E) Fugitive emissions component identification when Method 21 of appendix A-7 to this part is used to perform the monitoring survey.

(F) Ambient temperature, sky conditions, and maximum wind speed at the time of the survey. For compressor stations, operating mode of each compressor (*i.e.*, operating, standby pressurized, and not operating-depressurized modes) at the station at the time of the survey.

(G) Any deviations from the monitoring plan or a statement that there were no deviations from the monitoring plan.

(H) Records of calibrations for the instrument used during the monitoring survey.

(I) Documentation of each fugitive emission detected during the monitoring survey, including the information specified in paragraphs (c)(13)(v)(I)(1) through (9) of this section.

(1) Location of each fugitive emission identified.

(2) Type of fugitive emissions component, including designation as difficult-to-monitor or unsafe-to-monitor, if applicable.

(3) If Method 21 of appendix A-7 to this part is used for detection, record the component ID and instrument reading.

(4) For each repair that cannot be made during the monitoring survey when the fugitive emissions are initially found, a digital photograph or video must be taken of that component or the component must be tagged for identification purposes. The digital photograph must include the date that the photograph was taken and must clearly identify the component by location within the site (*e.g.*, the latitude and longitude of the component or by other descriptive landmarks visible in the picture). The digital photograph or identification (*e.g.*, tag) may be removed after the repair is completed, including verification of repair with the resurvey.

(5) The date of first attempt at repair of the fugitive emissions component(s).

(6) The date of successful repair of the fugitive emissions component, including the resurvey to verify repair and instrument used for the resurvey.

(7) Identification of each fugitive emission component placed on delay of repair and explanation for each delay of repair.

(8) For each fugitive emission component placed on delay of repair for reason of replacement component unavailability, the operator must document: the date the component was added to the delay of repair list, the date the replacement fugitive component or part thereof was ordered, the anticipated

component delivery date (including any estimated shipment or delivery date provided by the vendor), and the actual arrival date of the component.

(9) Date of planned shutdowns that occur while there are any components that have been placed on delay of repair.

(vi) For well closure activities, you must maintain the information specified in paragraphs (c)(13)(vi)(A) through (G) of this section.

(A) The well closure plan developed in accordance with § 60.5397c(l) and the date the plan was submitted.

(B) The notification of the intent to close the well site and the date the notification was submitted.

(C) The date of the cessation of production from all wells at the well site.

(D) The date you began well closure activities at the well site.

(E) Each status report for the well closure activities reported in paragraph (b)(8)(iv)(A) of this section.

(F) Each OGI survey reported in paragraph (b)(8)(iv)(B) of this section including the date, the monitoring instrument used, and the results of the survey or resurvey.

(G) The final OGI survey video demonstrating the closure of all wells at the site. The video must include the date that the video was taken and must identify the well site location by latitude and longitude.

(vii) If you comply with an alternative GHG standard under § 60.5398c, in lieu of the information specified in paragraphs (c)(13)(iv) and (v) of this section, you must maintain the records specified in § 60.5424c.

(14) For each pump designated facility, you must maintain the records identified in paragraphs (c)(14)(i) through (viii) of this section.

(i) Identification of each pump that is driven by natural gas and that is in operation 90 days or more per calendar year.

(ii) If you are complying with § 60.5395c(a) or (b)(1) by routing pump vapors to a process through a closed vent system, identification of all the natural gas-driven pumps in the pump designated facility for which you collect and route vapors to a process through a closed vent system and the records specified in paragraphs (c)(7), (9), and (11) of this section. If you comply with an alternative GHG and VOC standard under § 60.5398c, in lieu of the information specified in paragraph (c)(7) of this section, you must provide the information specified in § 60.5424c.

(iii) If you are complying with § 60.5395c(b)(1) by routing pump vapors to control device achieving a 95.0 percent reduction in methane

emissions, you must keep the records specified in paragraphs (c)(7) and (c)(9) through (c)(12) of this section. If you comply with an alternative GHG and VOC standard under § 60.5398c, in lieu of the information specified in paragraph (c)(7) of this section, you must provide the information specified in § 60.5424c.

(iv) If you are complying with § 60.5395c(b)(3) by routing pump vapors to a control device achieving less than a 95.0 percent reduction in methane emissions, you must maintain records of the certification that there is a control device on site but it does not achieve a 95.0 percent emissions reduction and a record of the design evaluation or manufacturer's specifications which indicate the percentage reduction the control device is designed to achieve.

(v) If you have less than three natural gas-driven diaphragm pumps in the pump designated facility, and you do not have a vapor recovery unit or control device installed on site by the compliance date, you must retain a record of your certification required under § 60.5395c(b)(4), certifying that there is no vapor recovery unit or control device on site. If you subsequently install a control device or vapor recovery unit, you must maintain the records required under paragraphs (c)(14)(ii) and (iii) or (iv) of this section, as applicable.

(vi) If you determine, through an engineering assessment, that it is technically infeasible to route the pump designated facility emissions to a process or control device, you must retain records of your demonstration and certification that it is technically infeasible as required under § 60.5395c(b)(7).

(vii) If the pump is routed to a process or control device that is subsequently removed from the location or is no longer available such that there is no option to route to a process or control device, you are required to retain records of this change and the records required under paragraph (c)(14)(vi) of this section.

(viii) Records of each change in compliance method, including identification of each natural gas-driven pump which changes its method of compliance, the new method of compliance, and the date of the change in compliance method.

(ix) Records of each deviation, the date and time the deviation began, the duration of the deviation, and a description of the deviation.

(d) *Electronic reporting.* If you are required to submit notifications or reports following the procedure specified in this paragraph (d), you must

submit notifications or reports to the EPA via CEDRI, which can be accessed through the EPA's Central Data Exchange (CDX) (<https://cdx.epa.gov/>). The EPA will make all the information submitted through CEDRI available to the public without further notice to you. Do not use CEDRI to submit information you claim as CBI. Although we do not expect persons to assert a claim of CBI, if you wish to assert a CBI claim for some of the information in the report or notification, you must submit a complete file in the format specified in this subpart, including information claimed to be CBI, to the EPA following the procedures in paragraphs (g)(1) and (2) of this section. Clearly mark the part or all of the information that you claim to be CBI. Information not marked as CBI may be authorized for public release without prior notice. Information marked as CBI will not be disclosed except in accordance with procedures set forth in 40 CFR part 2. All CBI claims must be asserted at the time of submission. Anything submitted using CEDRI cannot later be claimed CBI. Furthermore, under CAA section 114(c), emissions data is not entitled to confidential treatment, and the EPA is required to make emissions data available to the public. Thus, emissions data will not be protected as CBI and will be made publicly available. You must submit the same file submitted to the CBI office with the CBI omitted to the EPA via the EPA's CDX as described earlier in this paragraph (d).

(1) The preferred method to receive CBI is for it to be transmitted electronically using email attachments, File Transfer Protocol, or other online file sharing services. Electronic submissions must be transmitted directly to the OAQPS CBI Office at the email address oaqpscbi@epa.gov, and as described above, should include clear CBI markings. ERT files should be flagged to the attention of the Group Leader, Measurement Policy Group; all other files should be flagged to the attention of the Oil and Natural Gas Sector Lead. If assistance is needed with submitting large electronic files that exceed the file size limit for email attachments, and if you do not have your own file sharing service, please email oaqpscbi@epa.gov to request a file transfer link.

(2) If you cannot transmit the file electronically, you may send CBI information through the postal service to the following address: U.S. EPA, Attn: OAQPS Document Control Officer, Mail Drop: C404-02, 109 T.W. Alexander Drive, P.O. Box 12055, RTP, NC 27711. ERT files should be sent to the secondary attention of the Group

Leader, Measurement Policy Group, and all other files should be sent to the secondary attention of the Oil and Natural Gas Sector Lead. The mailed CBI material should be double wrapped and clearly marked. Any CBI markings should not show through the outer envelope.

(e) *Claims of EPA system outage.* If you are required to electronically submit a notification or report through CEDRI in the EPA's CDX, you may assert a claim of EPA system outage for failure to timely comply with that requirement. To assert a claim of EPA system outage, you must meet the requirements outlined in paragraphs (e)(1) through (7) of this section.

(1) You must have been or will be precluded from accessing CEDRI and submitting a required report within the time prescribed due to an outage of either the EPA's CEDRI or CDX systems.

(2) The outage must have occurred within the period of time beginning five business days prior to the date that the submission is due.

(3) The outage may be planned or unplanned.

(4) You must submit notification to the Administrator in writing as soon as possible following the date you first knew, or through due diligence should have known, that the event may cause or has caused a delay in reporting.

(5) You must provide to the Administrator a written description identifying:

(i) The date(s) and time(s) when CDX or CEDRI was accessed and the system was unavailable;

(ii) A rationale for attributing the delay in reporting beyond the regulatory deadline to EPA system outage;

(iii) A description of measures taken or to be taken to minimize the delay in reporting; and

(iv) The date by which you propose to report, or if you have already met the reporting requirement at the time of the notification, the date you reported.

(6) The decision to accept the claim of EPA system outage and allow an extension to the reporting deadline is solely within the discretion of the Administrator.

(7) In any circumstance, the report must be submitted electronically as soon as possible after the outage is resolved.

(f) *Claims of force majeure.* If you are required to electronically submit a report or notification through CEDRI in the EPA's CDX, you may assert a claim of *force majeure* for failure to timely comply with that requirement. To assert a claim of *force majeure*, you must meet the requirements outlined in paragraphs (f)(1) through (5) of this section.

(1) You may submit a claim if a *force majeure* event is about to occur, occurs, or has occurred or there are lingering effects from such an event within the period of time beginning five business days prior to the date the submission is due. For the purposes of this section, a *force majeure* event is defined as an event that will be or has been caused by circumstances beyond the control of the designated facility, its contractors, or any entity controlled by the designated facility that prevents you from complying with the requirement to submit a report electronically within the time period prescribed. Examples of such events are acts of nature (e.g., hurricanes, earthquakes, or floods), acts of war or terrorism, or equipment failure or safety hazard beyond the control of the designated facility (e.g., large scale power outage).

(2) You must submit notification to the Administrator in writing as soon as possible following the date you first knew, or through due diligence should have known, that the event may cause or has caused a delay in reporting.

(3) You must provide to the Administrator:

(i) A written description of the *force majeure* event;

(ii) A rationale for attributing the delay in reporting beyond the regulatory deadline to the *force majeure* event;

(iii) A description of measures taken or to be taken to minimize the delay in reporting; and

(iv) The date by which you propose to report, or if you have already met the reporting requirement at the time of the notification, the date you reported.

(4) The decision to accept the claim of *force majeure* and allow an extension to the reporting deadline is solely within the discretion of the Administrator.

(5) In any circumstance, the reporting must occur as soon as possible after the *force majeure* event occurs.

§ 60.5421c What are my additional recordkeeping requirements for process unit equipment designated facilities?

You must maintain a record of each equipment leak monitoring inspection and each leak identified under § 60.5400c and § 60.5401c as specified in paragraphs (b)(1) through (16) of this section. The record must be maintained either onsite or at the nearest local field office for at least 5 years. Any records required to be maintained that are submitted electronically via the EPA's CEDRI may be maintained in electronic format. This ability to maintain electronic copies does not affect the requirement for facilities to make records, data, and reports available

upon request to a delegated air agency or the EPA as part of an on-site compliance evaluation.

(a) You may comply with the recordkeeping requirements for multiple process unit equipment designated facilities in one recordkeeping system if the system identifies each record by each facility.

(b) You must maintain the monitoring inspection records specified in paragraphs (b)(1) through (16) of this section.

(1) Note that connectors need not be individually identified if all connectors in a designated area or length of pipe subject to the provisions of this subpart are identified as a group, and the number of connectors subject is indicated.

(2) Date and start and end times of the monitoring inspection.

(3) Inspector name.

(4) Leak determination method used for the monitoring inspection (*i.e.*, OGI, Method 21, or AVO).

(5) Monitoring instrument identification (OGI and Method 21 only).

(6) Type of equipment monitored.

(7) Process unit identification.

(8) The records specified in Section 12 of appendix K to this part, for each monitoring inspection conducted with OGI.

(9) The records in paragraph (b)(9)(i) through (vii) of this section, for each monitoring inspection conducted with Method 21 of appendix A-7 to this part.

(i) Instrument reading.

(ii) Date and time of instrument calibration and initials of operator performing the calibration.

(iii) Calibration gas cylinder identification, certification date, and certified concentration.

(iv) Instrument scale used.

(v) A description of any corrective action taken if the meter readout could not be adjusted to correspond to the calibration gas value in accordance with section 10.1 of Method 21 of appendix A-7 to this part.

(vi) Results of the daily calibration drift assessment.

(vii) If you make your own calibration gas, a description of the procedure used.

(10) For visual inspections of pumps in light liquid service, keep the records specified in paragraphs (b)(10)(i) through (iii) of this section, for each monitored equipment:

(i) Date of inspection.

(ii) Inspector name.

(iii) Result of inspection (*i.e.*, visual indications of liquids dripping from the pump seal or no visual indications of liquids dripping from the pump seal).

(11) For each leak detected, the records specified in paragraphs (b)(11)(i) through (v) of this section:

(i) The instrument and operator identification numbers and the process unit and equipment identification numbers. For leaks identified via visual, olfactory, audible methods, enter the specific sensory method for instrument identification number.

(ii) The date the leak was detected.

(iii) For each attempt to repair the leak, record:

(A) The date.

(B) The repair method applied.

(C) Indication of whether a leak was still detected following each attempt to repair the leak.

(vi) The date of successful repair of the leak and the method of monitoring used to confirm the repair, as specified in paragraph (b)(11)(vi)(A) through (C) of this section.

(A) If Method 21 of appendix A-7 to this part is used to confirm the repair, maintain a record of the maximum instrument reading measured by Method 21 of appendix A-7 to this part.

(B) If OGI conducted in accordance with appendix K to this part is used to confirm the repair, maintain a record of video footage of the repair confirmation.

(C) If the leak is repaired by eliminating AVO indications of a leak, maintain a record of the specific sensory method used to confirm that the evidence of the leak is eliminated.

(v) For each repair delayed beyond 15 calendar days after detection of the leak, record:

(A) "Repair delayed" and the reason for the delay.

(B) The signature of the certifying official who made the decision that repair could not be completed without a process shutdown.

(C) The expected date of successful repair of the leak.

(D) Dates of process unit shutdowns that occur while the equipment is unrepaired.

(12) A list of identification numbers for equipment that are designated for no detectable emissions complying with the provisions of § 60.5401c.

(13) A list of identification numbers for valves, pumps, and connectors that are designated as unsafe-to-monitor, an explanation for each valve, pump, or connector stating why the valve, pump, or connector is unsafe-to-monitor, and the plan for monitoring each valve, pump, or connector.

(14) A list of identification numbers for valves that are designated as difficult-to-monitor, an explanation for each valve stating why the valve is difficult-to-monitor, and the schedule for monitoring each valve.

(15) A list of identification numbers for equipment that is in vacuum service.

(16) A list of identification numbers for equipment you designate as having the potential to emit methane less than 300 hr/yr.

(17) A list of identification numbers for valves where it was infeasible to replace leaking valves with low-e valves or repack existing valves with low-e packing technology, including the reasoning for why it was infeasible.

§ 60.5422c What are my additional reporting requirements for process unit equipment designated facilities?

(a) You must submit semiannual reports using the appropriate electronic report template on the CEDRI website for this subpart and following the procedure specified in § 60.5420c(d). If the reporting form specific to this subpart is not available on the CEDRI website at the time that the report is due, submit the report to the Administrator at the appropriate address listed in § 60.4. Once the form has been available on the CEDRI website for at least 90 calendar days, you must begin submitting all subsequent reports via CEDRI. The date reporting forms become available will be listed on the CEDRI website. Unless the Administrator or delegated state agency or other authority has approved a different schedule for submission of reports, the report must be submitted within 45 days after the end of the semiannual reporting period, regardless of the method in which the report is submitted.

(b) The initial semiannual report must include the following information:

(1) The general information specified in paragraph (c)(1) of this section.

(2) For each process unit:

(i) Process unit identification.

(ii) Number of valves subject to the monitoring requirements of § 60.5400c(b) and § 60.5401c(f).

(iii) Number of pumps subject to the monitoring requirements of § 60.5400c(b) and § 60.5401c(b).

(iv) Number of connectors subject to the monitoring requirements of § 60.5400c(b) and § 60.5401c(h).

(v) Number of pressure relief devices subject to the monitoring requirements of § 60.5400c(b) and § 60.5401c(c).

(vi) The information in paragraphs (c)(3) and (4) of this section.

(c) All subsequent semiannual reports must include the following information:

(1) The general information specified in paragraphs (c)(1)(i) through (iii) of this section.

(i) The company name, facility site name, and address of the designated facility.

(ii) Beginning and ending dates of the reporting period.

(iii) A certification by a certifying official of truth, accuracy, and completeness. This certification shall state that, based on information and belief formed after reasonable inquiry, the statements and information in the document are true, accurate, and complete. If your report is submitted via CEDRI, the certifier's electronic signature during the submission process replaces the requirement in this paragraph (c)(1)(iii).

(2) Process unit identification for each process unit.

(3) For each month during the semiannual reporting period for each process unit report:

(i) Number of valves for which leaks were detected as described in § 60.5400c(b) or § 60.5401c(f).

(ii) Number of valves for which leaks were not repaired as required in § 60.5400c(h) or § 60.5401c(i) and the number of instances where it was technically infeasible to replace leaking valves with low-e valves or repack existing valves with low-e packing technology, including the reasoning for why it was technically infeasible.

(iii) Number of pumps for which leaks were detected as described in § 60.5400c(b) or § 60.5401c(b).

(iv) Number of pumps for which leaks were not repaired as required in § 60.5400c(h) or § 60.5401c(i).

(v) Number of connectors for which leaks were detected as described in § 60.5400c(b) or § 60.5401c(h).

(vi) Number of connectors for which leaks were not repaired as required in § 60.5400c(h) or § 60.5401c(i).

(vii) Number of pressure relief devices for which leaks were detected as described in § 60.5400c(b) or § 60.5401c(c).

(viii) Number of pressure relief devices for which leaks were not repaired as required in § 60.5400c(h) or § 60.5401c(i).

(ix) Number of open-ended valves or lines for which leaks were detected as described in § 60.5400c(e) or § 60.5401c(d).

(x) Number of open-ended valves or lines for which leaks were not repaired as required in § 60.5400c(h) or § 60.5401c(i).

(xi) Number of pumps, valves, or connectors in heavy liquid service or pressure relief device in light liquid or heavy liquid service for which leaks were detected as described in § 60.5400c(g) or § 60.5401c(g).

(xii) Number of pumps, valves, or connectors in heavy liquid service or pressure relief device in light liquid or heavy liquid service for which leaks

were not repaired as required in § 60.5400c(h) or § 60.5401c(i).

(xiii) The facts that explain each delay of repair and, where appropriate, why a process unit shutdown was technically infeasible.

(4) Dates of process unit shutdowns which occurred within the semiannual reporting period.

(5) Revisions to items reported according to paragraph (b) of this section if changes have occurred since the initial report or subsequent revisions to the initial report.

§ 60.5424c What are my additional recordkeeping and reporting requirements if I comply with the alternative GHG standards for fugitive emissions components designated facilities and covers and closed vent systems?

This section provides notification, reporting, and recordkeeping requirements for owners and operators who choose to comply with an alternative GHG standard as specified in § 60.5398c for fugitive emissions components designated facilities and the alternative continuous inspection and monitoring requirements for covers and closed vent systems. You must submit an annual report in accordance with the schedule in § 60.5420c(b) which includes the information in paragraphs (a)(1), (b), and (d) of this section, as applicable. You must submit the notification in paragraph (a)(2) of this section and maintain the records in paragraphs (c) and (e) of this section, as applicable.

(a) *Notifications.* If you choose to comply with an alternative GHG standard as specified in § 60.5398c for fugitive emissions components designated facilities and the alternative continuous inspection and monitoring requirements for covers and closed vent systems, you must submit the notification in paragraph (a)(1) of this section. If you are required by § 60.5398c(c)(8) to develop a mass emission rate reduction plan, you must submit the notification in paragraph (a)(2) of this section.

(1) A notification to the Administrator of adoption of the alternative standards in the annual report required by § 60.5420c(b)(3) through (10).

(2) A notification, which includes the submittal of the mass emission rate reduction plan required by § 60.5398c(c)(8). You must submit the mass emission rate reduction plan to the Administrator within 60 days of the initial exceedance of the action level.

(b) If you comply with the periodic screening requirements of § 60.5398c(b), you must submit the information in paragraphs (b)(1) through (6) of this

section in the annual report required by § 60.5420c(b)(3) through (10).

(1) Date of each periodic screening during the reporting period and date that results of the periodic screening were received.

(2) Alternative test method and technology used for each screening and the spatial resolution of the technology (*i.e.*, facility-level, area-level, or component level).

(3) Any deviations from the monitoring plan developed under § 60.5398c(b)(1) or a statement that there were no deviations from the monitoring plan.

(4) Results from each periodic screening during the reporting period. If the results of the periodic screening indicate a confirmed detection of emissions from a designated facility, you must submit the information in paragraphs (b)(4)(i) through (iv) of this section.

(i) The date that the monitoring survey of your entire or the required portion of your fugitive emissions components designated facility was conducted.

(ii) The date that you completed the instrument inspections of all required covers and closed vent systems(s).

(iii) The date that you conducted the visual inspection for emissions of all required closed vent systems and covers.

(iv) For each fugitive emission from a fugitive emissions components designated facility and all emissions or defects of each cover and closed vent system, you must submit the information in paragraphs (b)(4)(iv)(A) through (D) of this section.

(A) Number and type of components for which fugitive emissions were detected.

(B) Each emission or defect identified during the inspection for each cover and closed vent system.

(C) Date of repair for each fugitive emission from a fugitive emissions components designated facility or each emission or defect for each cover and closed vent system.

(D) Number and type of fugitive emission components and identification of each cover or closed vent system placed on delay of repair and an explanation for each delay of repair.

(5) The information in paragraphs (b)(5)(i) through (iv) of this section if you are required to conduct OGI surveys in accordance with § 60.5398c(b)(1)(i) or if you replace a periodic screening event with an OGI survey in accordance with § 60.5398c(b)(1)(iv).

(i) The date of the OGI survey.

(ii) Number and type of components for which fugitive emissions were detected.

(iii) Number and type of fugitive emissions components that were not repaired as required in § 60.5397c(h).

(iv) Number and type of fugitive emission components placed on delay of repair and an explanation for each delay of repair.

(6) Any additional information regarding the performance of the periodic screening technology as specified by the Administrator, as part of the alternative test method approval described in § 60.5398b(d).

(c) If you comply with the periodic screening requirements of § 60.5398c(b), you must maintain the records in paragraphs (c)(1) through (11) of this section in addition to the records as specified in § 60.5420c(c)(2) through (8) and (c)(13) and (14).

(1) The monitoring plan as required in § 60.5398c(b)(2).

(2) Date of each periodic screening and date that results of the periodic screening were received.

(3) Name of screening operator.

(4) Alternative test method and technology used for screening, as well as the aggregate detection threshold for the technology and the spatial resolution of the technology (*i.e.*, facility-level, area-level, or component-level).

(5) Records of calibrations for technology used during the screening, if calibration is required by the alternative test method approved in accordance with § 60.5398b(d).

(6) Results from periodic screening. If the results of the periodic screening indicate a confirmed detection of emissions from a designated facility, you must maintain the records in paragraphs (c)(6)(i) through (v) of this section.

(i) The date of the inspection of the fugitive emissions components and inspection of covers and closed vent system, as specified in § 60.5398c(b)(5).

(ii) Name of operator(s) performing the survey or inspection.

(iii) For surveys and instrument inspections, identification of the monitoring instrument(s) used.

(iv) Records of calibrations for the instrument(s) used during the survey or instrument inspection, as applicable.

(v) For each fugitive emission from a fugitive emissions components designated facility and each leak or defect for each cover and closed vent system inspection, you must maintain the records in paragraphs (c)(6)(v)(A) through (F) of this section.

(A) The location of the fugitive emissions identified using a unique

identifier for the source of the emissions and the type of fugitive emissions component.

(B) The location of the emission or defect from a cover or closed vent system using a unique identifier for the source of the emission or defect.

(C) If a defect of a closed vent system, cover, or control device is identified, a description of the defect.

(D) The date of repair for each fugitive emission from a fugitive emissions components designated facility or each emission or defect for each cover and closed vent system.

(E) Number and type of fugitive emission components and identification of each cover or closed vent system placed on delay of repair and an explanation for each delay of repair.

(F) For each fugitive emission component placed on delay of repair for reason of replacement component unavailability, the operator must document: the date the component was added to the delay of repair list, the date the replacement fugitive component or part thereof was ordered, the anticipated component delivery date (including any estimated shipment or delivery date provided by the vendor), and the actual arrival date of the component.

(7) The date the investigative analysis was initiated, and the result of the investigative analysis conducted in accordance with § 60.5398c(b)(5)(vi) and (vii), as applicable.

(8) Dates of implementation and completion of action(s) taken as a result of the investigative analysis and a description of the action(s) taken in accordance with § 60.5398c(b)(5)(vi) and (vii), as applicable.

(9) The information in paragraphs (c)(9)(i) through (vii) of this section if you are required to conduct OGI surveys in accordance with § 60.5398c(b)(1)(i) or if you replace a periodic screening event with an OGI survey in accordance with § 60.5398c(b)(1)(iv).

(i) The date of the OGI survey.

(ii) Location of each fugitive emission identified.

(iii) Type of fugitive emissions component for which fugitive emissions were detected.

(iv) The date of first attempt at repair of the fugitive emissions component(s).

(v) The date of successful repair of the fugitive emissions component(s), including the resurvey to verify the repair.

(vi) Identification of each fugitive emissions component placed on delay of repair and an explanation for each delay of repair.

(vii) For each fugitive emission component placed on delay of repair for reason of replacement component

unavailability, the operator must document: the date the component was added to the delay of repair list, the date the replacement fugitive component or part thereof was ordered, the anticipated component delivery date (including any estimated shipment or delivery date provided by the vendor), and the actual arrival date of the component.

(10) Any deviations from the monitoring plan or a statement that there were no deviations from the monitoring plan.

(11) All records required by the alternative approved in accordance with § 60.5398b(d).

(d) If you comply with the continuous monitoring system requirements of § 60.5398c(c), you must submit the information in paragraphs (d)(1) through (6) of this section in the annual report required by § 60.5420c(b)(3) through (10).

(1) The start date and end date for each period where the emissions rate determined in accordance with § 60.5398c(c)(6) exceeded one of the action levels determined in accordance with § 60.5398c(c)(4). Include which action level was exceeded (the 7-day or 90-day rolling average), the numerical value of the action level, and the mass emission rate calculated by the continuous monitoring system in the report.

(2) The date the investigative analysis was initiated, and the result of the investigative analysis conducted in accordance with § 60.5398c(c)(7), as applicable.

(3) Dates of implementation and completion of action(s) taken to reduce the mass emission rate and a description of the action(s) taken in accordance with § 60.5398c(c)(7), as applicable.

(4) If there are no instances reported under paragraph (d)(1) of this section, report your numerical action levels and the highest 7-day rolling average and highest 90-day rolling average determined by your continuous monitoring system during the reporting period.

(5) The start date for each instance where the 12-month rolling average operational downtime of the system exceeded 10 percent and the value of the 12-month rolling average operational downtime during the period. If there were no instances during the reporting period where the 12-month rolling average operational downtime of the system exceeded 10 percent, report the highest value of the 12-month rolling average operational downtime during the reporting period.

(6) Any additional information regarding the performance of the continuous monitoring system as

specified by the Administrator, as part of the alternative test method approval described in § 60.5398b(d).

(e) If you comply with the continuous monitoring system requirements of § 60.5398c(c), you must maintain the records in paragraphs (e)(1) through (15) of this section.

(1) The monitoring plan required by § 60.5398c(c)(2).

(2) Date of commencement of continuous monitoring with your continuous monitoring system.

(3) The detection threshold of the continuous monitoring system.

(4) The results of checks for power and function in accordance with § 60.5398c(c)(1)(ii).

(5) The beginning and end of each period of operational downtime for the system.

(6) Each rolling 12-month average operational downtime for the system, calculated in accordance with § 60.5398c(c)(1)(ii)(D).

(7) The 7-day rolling average and 90-day rolling average action levels for the site determined in accordance with § 60.5398c(c)(4).

(8) The information in paragraphs (e)(8)(i) through (v) of this section each time you establish site-specific baseline emissions in accordance with § 60.5398c(c)(5).

(i) Records of inspections of fugitive emissions components, covers, and closed vent systems required by § 60.5398c(c)(5)(i), including the date of inspection, location of each emission or defect identified, date of successful repair of each fugitive emissions component, cover, or closed vent system.

(ii) Records of inspections of control devices required by § 60.5398c(c)(5)(ii), including the date of the inspection and the results of the inspection.

(iii) The start date and time and end date and time of any maintenance activities that occurred during the 30 operating day period.

(iv) The site-level emission rate for each day during the 30 operating day period.

(v) The calculated site-specific baseline emission rate.

(9) Each methane mass emission rate reading determined by the system.

(10) Each daily, 7-day, and 90-day average mass emission rate which was determined in accordance with § 60.5398c(c)(6). If you exceed the 90-day action level, you must also keep records of the 30-day average mass emission rate following completion of the initial actions to reduce the average mass emission rate, in accordance with § 60.5398c(c)(8)(i).

(11) The results of each comparison of the emissions rate determined in

accordance with § 60.5398c(c)(6) to the action level determined in accordance with § 60.5398c(c)(4).

(12) The date the investigative analysis was initiated, and the result of the investigative analysis conducted in accordance with § 60.5398c(c)(7), as applicable.

(13) Dates of implementation and completion of action(s) taken to reduce the mass emission rate below the action level and a description of the action(s) taken in accordance with § 60.5398c(c)(7), as applicable.

(14) Each mass emission rate reduction plan developed in accordance with § 60.5398c(c)(8), as applicable. You must keep records of the actions taken in accordance with the plan and the date such actions are taken.

(15) Any additional information regarding the performance of the continuous monitoring technology as specified by the Administrator, as part of the alternative test method approval described in § 60.5398b(d).

§ 60.5425c What parts of the General Provisions apply to me?

Table 4 to this subpart shows which parts of the General Provisions in §§ 60.1 through 60.19 apply to you.

Model Rule—Definitions

§ 60.5430c What definitions apply to this subpart?

As used in this subpart, all terms not defined herein shall have the meaning given them in the Act or in subpart A of this part; and the following terms shall have the specific meanings given them.

Access to electrical power means commercial line power is available onsite, with sufficient capacity to support the required power loading of onsite equipment, and which provides reliable and consistent power.

Acid gas means a gas stream of hydrogen sulfide (H₂S) and carbon dioxide (CO₂) that has been separated from sour natural gas by a sweetening unit.

Alaskan North Slope means the approximately 69,000 square-mile area extending from the Brooks Range to the Arctic Ocean.

API Gravity means the weight per unit volume of hydrocarbon liquids as measured by a system recommended by the American Petroleum Institute (API) and is expressed in degrees.

Artificial lift equipment means mechanical pumps including, but not limited to, rod pumps and electric submersible pumps used to flowback fluids from a well.

Associated gas means the natural gas from wells operated primarily for oil

production that is released from the liquid hydrocarbon during the initial stage of separation after the wellhead. Associated gas production begins at the startup of production after the flow back period ends. Gas from wildcat or delineation wells is not associated gas.

Average aggregate detection threshold means:

(1) For the purposes of § 60.5398c, the average of all site-level detection thresholds from a single deployment (e.g., a singular flight that surveys multiple well sites, centralized production facility, and/or compressor stations) of a technology; and

(2) For the purposes of § 60.5388c, the average of all site-level detection thresholds from a single deployment in the same basin and field.

Bleed rate means the rate in standard cubic feet per hour at which natural gas is continuously vented (bleeds) from a process controller.

Capital expenditure means, as an alternative to the definition in § 60.2, an expenditure for a physical or operational change to an existing facility that:

(1) Exceeds P, the product of the facility's replacement cost, R, and an adjusted annual asset guideline repair allowance, A, as reflected by the following equation: $P = R \times A$, where:

(i) The adjusted annual asset guideline repair allowance, A, is the product of the percent of the replacement cost, Y, and the applicable basic annual asset guideline repair allowance, B, divided by 100 as reflected by the following equation: $A = Y \times (B \div 100)$;

(ii) The percent Y is determined from the following equation: $Y = (\text{CPI of date of construction/most recently available CPI of date of project})$, where the "CPI-U, U.S. city average, all items" must be used for each CPI value; and

(iii) The applicable basic annual asset guideline repair allowance, B, is 4.5.

(2) [Reserved]

Centralized production facility means one or more storage vessels and all equipment at a single surface site used to gather, for the purpose of sale or processing to sell, crude oil, condensate, produced water, or intermediate hydrocarbon liquid from one or more offsite natural gas or oil production wells. This equipment includes, but is not limited to, equipment used for storage, separation, treating, dehydration, artificial lift, combustion, compression, pumping, metering, monitoring, and flowline. Process vessels and process tanks are not considered storage vessels or storage tanks. A centralized production facility is located upstream of the natural gas

processing plant or the crude oil pipeline breakout station and is a part of producing operations.

Centrifugal compressor means any machine for raising the pressure of a natural gas by drawing in low pressure natural gas and discharging significantly higher-pressure natural gas by means of mechanical rotating vanes or impellers. Screw, sliding vane, and liquid ring compressors are not centrifugal compressors for the purposes of this subpart.

Centrifugal compressor equipped with sour seal oil separator and capture system means a wet seal centrifugal compressor system which has an intermediate closed process that degasses most of the gas entrained in the sour seal oil and sends that gas to either another process or combustion device (i.e., degassed emissions are recovered). The de-gas emissions are routed back to a process or combustion device directly from the intermediate closed degassing process; after the intermediate closed process the oil is ultimately recycled for recirculation in the seals to the lube oil tank where any small amount of residual gas is released through a vent.

Certifying official means one of the following:

(1) For a corporation: A president, secretary, treasurer, or vice-president of the corporation in charge of a principal business function, or any other person who performs similar policy or decision-making functions for the corporation, or a duly authorized representative of such person if the representative is responsible for the overall operation of one or more manufacturing, production, or operating facilities with a designated facility subject to this subpart and either:

(i) The facilities employ more than 250 persons or have gross annual sales or expenditures exceeding \$25 million (in second quarter 1980 dollars); or

(ii) The Administrator is notified of such delegation of authority prior to the exercise of that authority. The Administrator reserves the right to evaluate such delegation;

(2) For a partnership (including but not limited to general partnerships, limited partnerships, and limited liability partnerships) or sole proprietorship: A general partner or the proprietor, respectively. If a general partner is a corporation, the provisions of paragraph (1) of this definition apply;

(3) For a municipality, State, Federal, or other public agency: Either a principal executive officer or ranking elected official. For the purposes of this part, a principal executive officer of a Federal agency includes the chief executive officer having responsibility

for the overall operations of a principal geographic unit of the agency (e.g., a Regional Administrator of EPA); or

(4) For designated facilities:

(i) The designated representative in so far as actions, standards, requirements, or prohibitions under title IV of the CAA or the regulations promulgated thereunder are concerned; or

(ii) The designated representative for any other purposes under this part.

Closed vent system means a system that is not open to the atmosphere and that is composed of hard-piping, ductwork, connections, and, if necessary, flow-inducing devices that transport gas or vapor from a piece or pieces of equipment to a control device or back to a process.

Coil tubing cleanout means the process where an operator runs a string of coil tubing to the packed proppant within a well and jets the well to dislodge the proppant and provide sufficient lift energy to flow it to the surface. Coil tubing cleanout includes mechanical methods to remove solids and/or debris from a wellbore.

Collection system means any infrastructure that conveys gas or liquids from the well site to another location for treatment, storage, processing, recycling, disposal, or other handling.

Completion combustion device means any ignition device, installed horizontally or vertically, used in exploration and production operations to combust otherwise vented emissions from completions. Completion combustion devices include pit flares.

Compressor mode means the operational and pressurized status of a compressor. For both centrifugal compressors and reciprocating compressors, "mode" refers to either: Operating-mode, standby-pressurized-mode, or not-operating-depressurized-mode.

Compressor station means any permanent combination of one or more compressors that move natural gas at increased pressure through gathering or transmission pipelines, or into or out of storage. This includes, but is not limited to, gathering and boosting stations and transmission compressor stations. The combination of one or more compressors located at a well site, centralized production facility, or an onshore natural gas processing plant, is not a compressor station for purposes of § 60.5386c(e) and § 60.5397c.

Condensate means hydrocarbon liquid separated from natural gas that condenses due to changes in the temperature, pressure, or both, and remains liquid at standard conditions.

Connector means flanged, screwed, or other joined fittings used to connect two pipe lines or a pipe line and a piece of process equipment or that close an opening in a pipe that could be connected to another pipe. Joined fittings welded completely around the circumference of the interface are not considered connectors for the purpose of this regulation.

Continuous bleed means a continuous flow of pneumatic supply natural gas to a process controller.

Crude oil and natural gas source category means:

(1) Crude oil production, which includes the well and extends to the point of custody transfer to the crude oil transmission pipeline or any other forms of transportation; and

(2) Natural gas production, processing, transmission, and storage, which include the well and extend to, but do not include, the local distribution company custody transfer station.

Custody meter means the meter where natural gas or hydrocarbon liquids are measured for sales, transfers, and/or royalty determination.

Custody meter assembly means an assembly of fugitive emissions components, including the custody meter, valves, flanges, and connectors necessary for the proper operation of the custody meter.

Custody transfer means the transfer of crude oil or natural gas after processing and/or treatment in the producing operations, or from storage vessels or automatic transfer facilities or other such equipment, including product loading racks, to pipelines or any other forms of transportation.

Dehydrator means a device in which an absorbent directly contacts a natural gas stream and absorbs water in a contact tower or adsorption column (absorber).

Delineation well means a well drilled in order to determine the boundary of a field or producing reservoir.

Deviation means any instance in which a designated source subject to this subpart, or an owner or operator of such a source:

(1) Fails to meet any requirement or obligation established by this subpart including, but not limited to, any emission limit, operating limit, or work practice standard;

(2) Fails to meet any term or condition that is adopted to implement an applicable requirement in this subpart and that is included in the operating permit for any designated source required to obtain such a permit; or

(3) Fails to meet any emission limit, operating limit, or work practice

standard of this subpart during startup, shutdown, or malfunction, regardless of whether or not such failure is permitted by this subpart.

Distance piece means an open or enclosed casing through which the piston rod travels, separating the compressor cylinder from the crankcase.

Double block and bleed system means two block valves connected in series with a bleed valve or line that can vent the line between the two block valves.

Duct work means a conveyance system such as those commonly used for heating and ventilation systems. It is often made of sheet metal and often has sections connected by screw or crimping. Hard-piping is not ductwork.

Emergency shutdown device means a device which functions exclusively to protect personnel and/or prevent physical damage to equipment by shutting down equipment or gas flow during unsafe conditions resulting from an unexpected event, such as a pipe break or fire. For the purposes of this subpart, an emergency shutdown device is not used for routine control of operating conditions.

Equipment, as used in the standards and requirements of this subpart relative to the process unit equipment designated facility at onshore natural gas processing plants, means each pump, pressure relief device, open-ended valve or line, valve, and flange or other connector that has the potential to emit methane and any device or system required by those same standards and requirements of this subpart.

Field gas means feedstock gas entering the natural gas processing plant.

Field gas gathering means the system used transport field gas from a field to the main pipeline in the area.

First attempt at repair means an action taken for the purpose of stopping or reducing fugitive emissions to the atmosphere. First attempts at repair include, but are not limited to, the following practices where practicable and appropriate: Tightening bonnet bolts; replacing bonnet bolts; tightening packing gland nuts; or injecting lubricant into lubricated packing.

Flare means a thermal oxidation system using an open (without enclosure) flame. Completion combustion devices as defined in this section are not considered flares.

Flow line means a pipeline used to transport oil and/or gas to a processing facility or a mainline pipeline.

Flowback means the process of allowing fluids and entrained solids to flow from a well following a treatment, either in preparation for a subsequent phase of treatment or in preparation for

cleanup and returning the well to production. The term flowback also means the fluids and entrained solids that emerge from a well during the flowback process. The flowback period begins when material introduced into the well during the treatment returns to the surface following hydraulic fracturing or refracturing. The flowback period ends when either the well is shut in and permanently disconnected from the flowback equipment or at the startup of production. The flowback period includes the initial flowback stage and the separation flowback stage. Screenouts, coil tubing cleanouts, and plug drill-outs are not considered part of the flowback process.

Fuel gas means gases that are combusted to derive useful work or heat.

Fuel gas system means the offsite and onsite piping and flow and pressure control system that gathers gaseous stream(s) generated by onsite operations, may blend them with other sources of gas, and transports the gaseous stream for use as fuel gas in combustion devices or in-process combustion equipment, such as furnaces and gas turbines, either singly or in combination.

Fugitive emissions means, for the purposes of § 60.5397c, any indication of emissions observed from a fugitive emissions component using AVO, an indication of visible emissions observed from an OGI instrument, or an instrument reading of 500 ppmv or greater using Method 21 of appendix A-7 to this part.

Fugitive emissions component means any component that has the potential to emit fugitive emissions of methane at a well site, centralized production facility, or compressor station, such as valves (including separator dump valves), connectors, pressure relief devices, open-ended lines, flanges, devices and closed vent systems not subject to § 60.5411c, thief hatches or other openings on a storage vessel not subject to § 60.5396c, compressors, instruments, meters, and yard piping.

Gas to oil ratio (GOR) means the ratio of the volume of gas at standard temperature and pressure that is produced from a volume of oil when depressurized to standard temperature and pressure.

Hard-piping means pipe or tubing that is manufactured and properly installed using good engineering judgment and standards such as ASME B31.3, Process Piping (available from the American Society of Mechanical Engineers, P.O. Box 2300, Fairfield, NJ 07007-2300).

Hydraulic fracturing means the process of directing pressurized fluids

containing any combination of water, proppant, and any added chemicals to penetrate tight formations, such as shale or coal formations, that subsequently require high rate, extended flowback to expel fracture fluids and solids during completions.

Hydraulic refracturing means conducting a subsequent hydraulic fracturing operation at a well that has previously undergone a hydraulic fracturing operation.

In gas/vapor service means that the piece of equipment contains process fluid that is in the gaseous state at operating conditions.

In heavy liquid service means that the piece of equipment is not in gas/vapor service or in light liquid service.

In light liquid service means that the piece of equipment contains a liquid that meets the conditions specified in § 60.5402c(d)(2) or § 60.5406c.

In vacuum service means that equipment is operating at an internal pressure which is at least 5 kilopascals (kPa) (0.7 psia) below ambient pressure.

In wet gas service means that a compressor or piece of equipment contains or contacts the field gas before the extraction step at a gas processing plant process unit.

Initial calibration value, as used in the standards and requirements of this subpart relative to the process unit equipment designated facility at onshore natural gas processing plants, means the concentration measured during the initial calibration at the beginning of each day required in § 60.5403c, or the most recent calibration if the instrument is recalibrated during the day (*i.e.*, the calibration is adjusted) after a calibration drift assessment.

Initial flowback stage means the period during a well completion operation which begins at the onset of flowback and ends at the separation flowback stage.

Intermediate hydrocarbon liquid means any naturally occurring, unrefined petroleum liquid.

Intermittent vent natural gas-driven process controller means a process controller that is not designed to have a continuous bleed rate but is instead designed to only release natural gas to the atmosphere as part of the actuation cycle.

Liquefied natural gas unit means a unit used to cool natural gas to the point at which it is condensed into a liquid which is colorless, odorless, non-corrosive and non-toxic.

Liquid collection system means tankage and/or lines at a well site to contain liquids from one or more wells or to convey liquids to another site.

Liquids dripping means any visible leakage from the seal, including spraying, misting, clouding, and ice formation.

Liquids unloading means the unloading of liquids that have accumulated over time in gas wells, which are impeding or halting production. Routine well maintenance activities, including workovers, screenouts, coil tubing cleanouts, or any other activity that requires a rig or other machinery are not considered liquids unloading.

Local distribution company (LDC) custody transfer station means a metering station where the LDC receives a natural gas supply from an upstream supplier, which may be an interstate transmission pipeline or a local natural gas producer, for delivery to customers through the LDC's intrastate transmission or distribution lines.

Low-e valve means a valve (including its specific packing assembly) for which the manufacturer has issued a written warranty or performance guarantee that it will not emit fugitives at greater than 100 ppm in the first five years. A valve may qualify as a low-e valve if it is as an extension of another valve that has qualified as a low-e valve.

Low-e packing means a valve packing product for which the manufacturer has issued a written warranty or performance guarantee that it will not emit fugitives at greater than 100 ppm in the first five years. Low-e injectable packing is a type of low-e packing product for which the manufacturer has also issued a written warranty or performance guarantee and that can be injected into a valve during a "drill-and-tap" repair of the valve.

Major production and processing equipment means reciprocating or centrifugal compressors, glycol dehydrators, heater/treaters, separators, control devices, natural gas-driven process controllers, natural gas-driven pumps, and storage vessels or tank batteries collecting crude oil, condensate, intermediate hydrocarbon liquids, or produced water, for the purpose of determining whether a well site is a wellhead only well site.

Maximum average daily throughput means the following:

(1) The earliest calculation of daily average throughput, determined as described in paragraph (2) or (3) of this definition, to a tank battery over the days that production is routed to that tank battery during the 30-day PTE evaluation period employing generally accepted methods specified in § 60.5386c(e)(2).

(2) If throughput to the tank battery is measured on a daily basis (e.g., via level

gauge automation or daily manual gauging), the maximum average daily throughput is the average of all daily throughputs for days on which throughput was routed to the tank battery during the 30-day evaluation period; or

(3) If throughput to the tank battery is not measured on a daily basis (e.g., via manual gauging at the start and end of loadouts), the maximum average daily throughput is the highest, of the average daily throughputs, determined for any production period to that tank battery during the 30-day evaluation period, as determined by averaging total throughput to that tank battery over each production period. A production period begins when production begins to be routed to a tank battery and ends either when throughput is routed away from that tank battery or when a loadout occurs from that tank battery, whichever happens first. Regardless of the determination methodology, operators must not include days during which throughput is not routed to the tank battery when calculating maximum average daily throughput for that tank battery.

Multi-wellhead only well site means a well site that contains two or more wellheads and no major production and processing equipment.

Natural gas-driven diaphragm pump means a positive displacement pump powered by pressurized natural gas that uses the reciprocating action of flexible diaphragms in conjunction with check valves to pump a fluid. A pump in which a fluid is displaced by a piston driven by a diaphragm is not considered a diaphragm pump for purposes of this subpart. A lean glycol circulation pump that relies on energy exchange with the rich glycol from the contactor is not considered a diaphragm pump.

Natural gas-driven piston pump means a positive displacement pump powered by pressurized natural gas that moves and pressurizes fluid by using one or more reciprocating pistons. A pump in which a fluid is displaced by a piston driven by a diaphragm is considered a piston pump for purposes of this subpart. A lean glycol circulation pump that relies on energy exchange with the rich glycol from the contactor is not considered a piston pump.

Natural gas-driven process controller means a process controller powered by pressurized natural gas.

Natural gas liquids means the hydrocarbons, such as ethane, propane, butane, and pentane that are extracted from field gas.

Natural gas processing plant (gas plant) means any processing site engaged in the extraction of natural gas

liquids from field gas, fractionation of mixed natural gas liquids to natural gas products, or both. A Joule-Thompson valve, a dew point depression valve, or an isolated or standalone Joule-Thompson skid is not a natural gas processing plant.

Natural gas transmission means the pipelines used for the long-distance transport of natural gas (excluding processing). Specific equipment used in natural gas transmission includes the land, mains, valves, meters, boosters, regulators, storage vessels, dehydrators, compressors, and their driving units and appurtenances, and equipment used for transporting gas from a production plant, delivery point of purchased gas, gathering system, storage area, or other wholesale source of gas to one or more distribution area(s).

No detectable emissions means, for the purposes of §§ 60.5401c and 60.5406c, that the equipment is operating with an instrument reading of less than 500 ppmv above background, as determined by Method 21 of appendix A-7 to this part.

No identifiable emissions means, for the purposes of covers, closed vent systems, and self-contained natural gas-driven process controllers and as determined according to the provisions of § 60.5416c, that no emissions are detected by AVO means when inspections are conducted by AVO; no emissions are imaged with an OGI camera when inspections are conducted with OGI; and equipment is operating with an instrument reading of less than 500 ppmv above background, as determined by Method 21 of appendix A-7 to this part when inspections are conducted with Method 21.

Nonfractionating plant means any gas plant that does not fractionate mixed natural gas liquids into natural gas products.

Non-natural gas-driven process controller means an instrument that is actuated using other sources of power than pressurized natural gas; examples include solar, electric, and instrument air.

Onshore means all facilities except those that are located in the territorial seas or on the outer continental shelf.

Open-ended valve or line or open-ended vent line means any valves, except safety relief valves, having one side of the valve seat in contact with process fluid and one side open to the atmosphere, either directly or through open piping.

Plug drill-out means the removal of a plug (or plugs) that was used to isolate different sections of the well.

Process controller means an automated instrument used for

maintaining a process condition such as liquid level, pressure, delta-pressure and temperature.

Pressure release means the emission of materials resulting from system pressure being greater than set pressure of the pressure relief device.

Pressure vessel means a storage vessel that is used to store liquids or gases and is designed not to vent to the atmosphere as a result of compression of the vapor headspace in the pressure vessel during filling of the pressure vessel to its design capacity.

Pressurized mode means when the compressor contains natural gas that is maintained at a pressure higher than the atmospheric pressure.

Process improvement means routine changes made for safety and occupational health requirements, for energy savings, for better utility, for ease of maintenance and operation, for correction of design deficiencies, for bottleneck removal, for changing product requirements, or for environmental control.

Process unit means components assembled for the extraction of natural gas liquids from field gas, the fractionation of the liquids into natural gas products, or other operations associated with the processing of natural gas products. A process unit can operate independently if supplied with sufficient feed or raw materials and sufficient storage facilities for the products.

Process unit shutdown means a work practice or operational procedure that stops production from a process unit or part of a process unit during which it is technically feasible to clear process material from a process unit or part of a process unit consistent with safety constraints and during which repairs can be accomplished. The following are not considered process unit shutdowns:

(1) An unscheduled work practice or operational procedure that stops production from a process unit or part of a process unit for less than 24 hours.

(2) An unscheduled work practice or operational procedure that would stop production from a process unit or part of a process unit for a shorter period of time than would be required to clear the process unit or part of the process unit of materials and start up the unit, and would result in greater emissions than delay of repair of leaking components until the next scheduled process unit shutdown.

(3) The use of spare equipment and technically feasible bypassing of equipment without stopping production.

Produced water means water that is extracted from the earth from an oil or

natural gas production well, or that is separated from crude oil, condensate, or natural gas after extraction.

Qualified Professional Engineer means an individual who is licensed by a state as a Professional Engineer to practice one or more disciplines of engineering and who is qualified by education, technical knowledge and experience to make the specific technical certifications required under this subpart. Professional engineers making these certifications must be currently licensed in at least one state in which the certifying official is located.

Quarter means a 3-month period. For purposes of standards for process unit equipment designated facilities at onshore natural gas processing plants, the first quarter concludes on the last day of the last full month during the 180 days following initial startup.

Reciprocating compressor means a piece of equipment that increases the pressure of a process gas by positive displacement, employing linear movement of the driveshaft.

Reciprocating compressor rod packing means a series of flexible rings in machined metal cups that fit around the reciprocating compressor piston rod to create a seal limiting the amount of compressed natural gas that escapes to the atmosphere, or other mechanism that provides the same function.

Recovered gas means gas recovered through the separation process during flowback.

Recovered liquids means any crude oil, condensate or produced water recovered through the separation process during flowback.

Reduced emissions completion means a well completion following fracturing or refracturing where gas flowback that is otherwise vented is captured, cleaned, and routed to the gas flow line or collection system, re-injected into the well or another well, used as an onsite fuel source, or used for other useful purpose that a purchased fuel or raw material would serve, with no direct release to the atmosphere.

Reduced sulfur compounds means H₂S, carbonyl sulfide (COS), and carbon disulfide (CS₂).

Removed from service means that a storage vessel designated facility has been physically isolated and disconnected from the process for a purpose other than maintenance in accordance with § 60.5396c(c)(1).

Repaired means the following:

(1) For the purposes of fugitive emissions components designated facilities, that fugitive emissions components are adjusted, replaced, or otherwise altered, in order to eliminate

fugitive emissions as defined in § 60.5397c and resurveyed as specified in § 60.5397c(h)(4) and it is verified that emissions from the fugitive emissions components are below the applicable fugitive emissions definition.

(2) For the purposes of process unit equipment designated facilities, that equipment is adjusted, or otherwise altered, in order to eliminate a leak as defined in §§ 60.5400c and 60.5401c and is re-monitored as specified in § 60.5400c(b) and (b)(1) or § 60.5403c, respectively, to verify that emissions from the equipment are below the applicable leak definition. Pumps in light liquid service subject to § 60.5400c(c)(2) or § 60.5401c(b)(1)(ii) are not subject to re-monitoring.

Replacement cost means the capital needed to purchase all the depreciable components in a facility.

Returned to service means that a storage vessel designated facility that was removed from service has been:

(1) Reconnected to the original source of liquids or has been used to replace any storage vessel designated facility; or

(2) Installed in any location covered by this subpart and introduced with crude oil, condensate, intermediate hydrocarbon liquids or produced water.

Routed to a process or route to a process means the emissions are conveyed via a closed vent system to any enclosed portion of a process that is operational where the emissions are predominantly recycled and/or consumed in the same manner as a material that fulfills the same function in the process and/or transformed by chemical reaction into materials that are not regulated materials and/or incorporated into a product; and/or recovered.

Salable quality gas means natural gas that meets the flow line or collection system operator specifications, regardless of whether such gas is sold.

Screenout means an attempt to clear proppant from the wellbore to dislodge the proppant out of the well.

Self-contained process controller means a natural gas-driven process controller that releases gas into the downstream piping and not to the atmosphere, resulting in zero methane emissions.

Self-contained wet seal centrifugal compressor means:

(1) A wet seal centrifugal compressor system that is a closed process that ports the degassing emissions into the natural gas line at the compressor suction (*i.e.*, degassed emissions are recovered) or which has an intermediate closed process that degasses most of the gas entrained in the seal oil and sends that gas to another process. The de-gas

emissions are routed back to suction or process directly from the closed or intermediate closed degassing process; after the closed or intermediate closed degassing process the oil is ultimately recycled for recirculation in the seals to the lube oil tank where any small amount of residual gas is released through a vent.

(2) A wet seal centrifugal compressor equipped with mechanical wet seals, where (1) a differential pressure is maintained on the system and there is no off gassing of the lube oil, and (2) the mechanical seal is integrated into the compressor housing.

Sensor means a device that measures a physical quantity or the change in a physical quantity such as temperature, pressure, flow rate, pH, or liquid level.

Separation flowback stage means the period during a well completion operation when it is technically feasible for a separator to function. The separation flowback stage ends either at the startup of production, or when the well is shut in and permanently disconnected from the flowback equipment.

Separator dump valve means, for purposes of the fugitive emission standards in §§ 60.5397c and 60.5398c, a liquid-control valve in a separator that controls the liquid level within the separator vessel.

Single wellhead only well site means a wellhead only well site that contains only one wellhead and no major production and processing equipment.

Small well site means, for purposes of the fugitive emissions standards in §§ 60.5397c and 60.5398c, a well site that contains a single wellhead, no more than one piece of certain major production and processing equipment, and associated meters and yard piping. Small well sites cannot include any controlled storage vessels (or controlled tank batteries), control devices, or natural gas-driven process controllers, or natural gas-driven pumps.

Startup of production means the beginning of initial flow following the end of flowback when there is continuous recovery of salable quality gas and separation and recovery of any crude oil, condensate, or produced water, except as otherwise provided in this definition. For the purposes of the fugitive monitoring requirements of § 60.5397c, *startup of production* means the beginning of the continuous recovery of salable quality gas and separation and recovery of any crude oil, condensate, or produced water.

Storage vessel means a tank or other vessel that contains an accumulation of crude oil, condensate, intermediate hydrocarbon liquids, or produced water,

and that is constructed primarily of nonearthen materials (such as wood, concrete, steel, fiberglass, or plastic) which provide structural support. A well completion vessel that receives recovered liquids from a well after startup of production following flowback for a period which exceeds 60 days is considered a storage vessel under this subpart. A tank or other vessel shall not be considered a storage vessel if it has been removed from service in accordance with the requirements of § 60.5396c(c)(1) until such time as such tank or other vessel has been returned to service. For the purposes of this subpart, the following are not considered storage vessels:

(1) Vessels that are skid-mounted or permanently attached to something that is mobile (such as trucks, railcars, barges or ships), and are intended to be located at a site for less than 180 consecutive days. If you do not keep or are not able to produce records, as required by § 60.5420c(c)(4)(iv), showing that the vessel has been located at a site for less than 180 consecutive days, the vessel described herein is considered to be a storage vessel from the date the original vessel was first located at the site. This exclusion does not apply to a well completion vessel as described above.

(2) Process vessels such as surge control vessels, bottoms receivers or knockout vessels.

(3) Pressure vessels designed to operate in excess of 204.9 kilopascals and without emissions to the atmosphere.

Sulfur production rate means the rate of liquid sulfur accumulation from the sulfur recovery unit.

Sulfur recovery unit means a process device that recovers element sulfur from acid gas.

Surface site means any combination of one or more graded pad sites, gravel pad sites, foundations, platforms, or the immediate physical location upon which equipment is physically affixed.

Sweetening unit means a process device that removes hydrogen sulfide and/or carbon dioxide from the sour natural gas stream.

Tank battery means a group of all storage vessels that are manifolded together for liquid transfer. A tank battery may consist of a single storage vessel if only one storage vessel is present.

Total Reduced Sulfur (TRS) means the sum of the sulfur compounds hydrogen sulfide, methyl mercaptan, dimethyl sulfide, and dimethyl disulfide as measured by Method 16 of appendix A–6 to this part.

Total SO₂ equivalents means the sum of volumetric or mass concentrations of the sulfur compounds obtained by adding the quantity existing as SO₂ to the quantity of SO₂ that would be obtained if all reduced sulfur compounds were converted to SO₂ (ppmv or kg/dscm (lb/dscf)).

UIC Class I oilfield disposal well means a well with a UIC Class I permit that meets the definition in 40 CFR 144.6(a)(2) and receives eligible fluids from oil and natural gas exploration and production operations.

UIC Class II oilfield disposal well means a well with a UIC Class II permit where wastewater resulting from oil and natural gas production operations is injected into underground porous rock formations not productive of oil or gas, and sealed above and below by unbroken, impermeable strata.

Underground storage vessel means a storage vessel stored below ground.

Well means a hole drilled for the purpose of producing oil or natural gas, or a well into which fluids are injected.

Well completion means the process that allows for the flowback of petroleum or natural gas from newly drilled wells to expel drilling and reservoir fluids and tests the reservoir flow characteristics, which may vent produced hydrocarbons to the atmosphere via an open pit or tank.

Well completion operation means any well completion with hydraulic fracturing or refracturing occurring at a well completion designated facility.

Well completion vessel means a vessel that contains flowback during a well completion operation following hydraulic fracturing or refracturing. A well completion vessel may be a lined earthen pit, a tank or other vessel that is skid-mounted or portable. A well completion vessel that receives recovered liquids from a well after startup of production following flowback for a period which exceeds 60 days is considered a storage vessel under this subpart.

Well site means one or more surface sites that are constructed for the drilling and subsequent operation of any oil well, natural gas well, or injection well. For the purposes of the fugitive emissions standards at § 60.5397c, a well site does not include:

(1) UIC Class II oilfield disposal wells and disposal facilities;

(2) UIC Class I oilfield disposal wells; and

(3) The flange immediately upstream of the custody meter assembly and equipment, including fugitive emissions components, located downstream of this flange.

Wellhead means the piping, casing, tubing and connected valves protruding above the earth's surface for an oil and/or natural gas well. The wellhead ends where the flow line connects to a wellhead valve. The wellhead does not include other equipment at the well site except for any conveyance through which gas is vented to the atmosphere.

Wellhead only well site means, for the purposes of the fugitive emissions standards at § 60.5397c and the standards in § 60.5398c, a well site that contains one or more wellheads and no major production and processing equipment.

Wildcat well means a well outside known fields or the first well drilled in

an oil or gas field where no other oil and gas production exists.

Yard piping means hard-piping at a well site, centralized production facility, or compressor station that is not part of a closed vent system.

§§ 60.5431c–60.5439c [Reserved]

TABLE 1 TO SUBPART OOOOc OF PART 60—DESIGNATED FACILITY PRESUMPTIVE STANDARDS AND REGULATED ENTITY COMPLIANCE DATES

Designated facility	Model rule presumptive standards section	Regulated entity compliance dates
Wells	a. Gas wells liquids unloading events—§ 60.5390c	36 months after the state plan submittal deadline specified in § 60.5362c(c).
Centrifugal Compressors	b. Associated gas wells—§ 60.5391c.	
Reciprocating Compressors	§ 60.5392c.	
Process Controller	§ 60.5393c.	
Pump	§ 60.5394c.	
Storage Vessels	§ 60.5395c.	
Fugitive Emissions Components	§ 60.5396c.	
Super Emitter Emissions Events	a. Primary standards—§ 60.5397c.	
Process Unit Equipment	b. Alternative standards for fugitive emissions components and covers and closed vent systems—§ 60.5398c.	
	§ 60.5388c.	
	a. Onshore natural gas processing plants—§ 60.5400c.	
	b. Process unit equipment alternative standards—§ 60.5401c.	
	c. Process unit equipment requirement exceptions—§ 60.5401c.	

TABLE 2 TO SUBPART OOOOc OF PART 60—ALTERNATIVE TECHNOLOGY PERIODIC SCREENING FREQUENCY AT WELL SITES, CENTRALIZED PRODUCTION FACILITIES, AND COMPRESSOR STATIONS SUBJECT TO AVO INSPECTIONS WITH QUARTERLY OGI OR EPA METHOD 21 MONITORING

Minimum screening frequency	Minimum detection threshold of screening technology* (kg/hr)
Quarterly	≤1
Bimonthly	≤2
Bimonthly + Annual OGI	≤10
Monthly	≤5
Monthly + Annual OGI	≤15

* Based on a probability of detection of 90%.

TABLE 3 TO SUBPART OOOOc OF PART 60—ALTERNATIVE TECHNOLOGY PERIODIC SCREENING FREQUENCY AT WELL SITES AND CENTRALIZED PRODUCTION FACILITIES SUBJECT TO AVO INSPECTIONS AND/OR SEMIANNUAL OGI OR EPA METHOD 21 MONITORING

Minimum screening frequency	Minimum detection threshold of screening technology* (kg/hr)
Semiannual	≤1
Triannual	≤2
Triannual + Annual OGI	≤10
Quarterly	≤5
Quarterly + Annual OGI	≤15
Bimonthly	≤15

* Based on a probability of detection of 90%.

TABLE 4 TO SUBPART OOOOc OF PART 60—APPLICABILITY OF GENERAL PROVISIONS TO SUBPART OOOOc

General provisions citation	Subject of citation	Applies to subpart?	Explanation
§ 60.1	General applicability of the General Provisions.	Yes.	
§ 60.2	Definitions	Yes	Additional terms defined in § 60.5430c.
§ 60.3	Units and abbreviations	Yes.	

TABLE 4 TO SUBPART OOOOc OF PART 60—APPLICABILITY OF GENERAL PROVISIONS TO SUBPART OOOOc—Continued

General provisions citation	Subject of citation	Applies to subpart?	Explanation
§ 60.4	Address	Yes.	
§ 60.5	Determination of construction or modification.	Yes.	
§ 60.6	Review of plans	Yes.	
§ 60.7	Notification and record keeping	Yes	Except that § 60.7 only applies as specified in §§ 60.5417c(c) and 60.5420c(a).
§ 60.8	Performance tests	Yes	Except that the format and submittal of performance test reports is described in § 60.5420c(b) and (d). Performance testing is required for control devices used on storage vessels, centrifugal compressors, and pumps, except that performance testing is not required for a control device used solely on pump(s).
§ 60.9	Availability of information	Yes.	
§ 60.10	State authority	Yes.	
§ 60.11	Compliance with standards and maintenance requirements.	No	Requirements are specified in subpart OOOOc.
§ 60.12	Circumvention	Yes.	
§ 60.13	Monitoring requirements	Yes	Continuous monitors are required for storage vessels.
§ 60.14	Modification	Yes	To the extent any provision in § 60.14 conflicts with specific provisions in subpart OOOOc, it is superseded by subpart OOOOc provisions.
§ 60.15	Reconstruction	Yes	Except that § 60.15(d) does not apply to wells (i.e., well completions, well liquids unloading, associated gas wells), process controllers, pumps, centrifugal compressors, reciprocating compressors, storage vessels, or fugitive emissions components designated facilities.
§ 60.16	Priority list	Yes.	
§ 60.17	Incorporations by reference	Yes.	
§ 60.18	General control device and work practice requirements.	Yes.	
§ 60.19	General notification and reporting requirement.	Yes.	

■ 34. Add appendix J and appendix K to part 60 to read as follows:

Appendix J to Part 60 [Reserved]

Appendix K to Part 60—Determination of Volatile Organic Compound and Greenhouse Gas Leaks Using Optical Gas Imaging

1.0 Scope and Application

1.1 Analytes.

Analytes	CAS No.
Volatile Organic Compounds (VOCs).	No CAS number assigned.
Methane	74–82–8.
Ethane	74–84–0.

1.1.1 This protocol is applicable to the detection of VOCs, including hazardous air pollutants, and hydrocarbons, such as methane and ethane.

1.2 *Scope.* This protocol covers surveys of process equipment using Optical Gas Imaging (OGI) cameras in sectors where the majority of constituents (>75 percent by volume) in the emissions streams have a response factor of at least 0.25 when compared to the response factor of propane and can be imaged by the equipment specified in Section 6.0. The specific component focus for the surveys is determined by the referencing subpart, and can include, but is not limited to, valves, flanges, connectors, pumps, compressors, open-ended lines, pressure relief devices, and seal systems.

1.3 *Applicability.* This protocol is applicable to facilities when specified in a referencing subpart. This protocol is intended to help determine the presence and location of leaks and is not currently applicable for use in direct emission rate measurements from sources.

2.0 Summary

2.1 A field portable infrared (IR) camera capable of imaging the target gas species is employed to survey process equipment and locate fugitive or leaking gas emissions. By restricting the amount of incoming thermal radiation to a small bandwidth corresponding to a region of interaction for the gas species of interest, the camera provides an image of an invisible gas to the camera operator. The camera type and manufacturer are not specified in this protocol, but the camera used must meet the specifications and performance criteria presented in Section 6. The keys to becoming proficient and maintaining leak detection proficiency using OGI cameras are proper camera operator training with sufficient field experience and conducting OGI surveys frequently throughout the year.

3.0 Definitions

Ambient air temperature means the air temperature in the general location of the component being surveyed.

Camera configuration means different ways of setting up an OGI camera that affect its detection capability. Examples of camera configurations that can be changed include the operating mode (e.g., standard versus high sensitivity or enhanced), the lens, the

portability (e.g., handheld versus tripod), and the viewer (e.g., OGI camera screen versus an external device like a tablet).

Delta temperature (delta-T or ΔT) means the difference in temperature between the emitted process gas temperature and the surrounding background temperature. It is an acceptable practice in the field to assume that the emitted process gas temperature is equal to the ambient air temperature.

Dwell time means the minimum amount of time required to survey a scene in order to provide adequate probability of leak detection. The dwell time is the active time the operator is looking for potential leaks and does not begin until the scene is in focus and steady.

Fugitive emission or leak means any emissions observed using OGI from components regulated by the referencing subpart.

Imaging is the process of producing a visual representation of emissions that may otherwise be invisible to the naked eye.

Monitoring survey means imaging equipment with an OGI camera at one site on one day. Changing the site being surveyed or changing the day of imaging constitutes a new monitoring survey.

OGI camera operator is someone who has completed the training required in Section 10 and passed the final survey test in Section 10.2.2.4.

Operating envelope means the range of conditions (i.e., wind speed, delta-T, viewing distance) within which a survey must be conducted to achieve the quality objective.

Optical gas imaging camera means any field portable instrumentation that makes

visible emissions that may otherwise be invisible to the naked eye.

Persistent leak is any leak that is not intermittent in nature.

Referencing subpart means a subpart in this part or in 40 CFR part 61, 62, 63, or 65 that requires the monitoring of regulated equipment for fugitive emissions or leaks, for which this protocol is referenced.

Response factor means the OGI camera's response to a compound of interest relative to a reference compound at a concentration path-length of 10,000 parts per million-meter. Response factors are specific to the OGI camera model and can be obtained from peer reviewed articles or may be developed according to procedures specified in Annex 1 of this appendix K.

Senior OGI camera operator is a camera operator who has conducted OGI surveys for a minimum of 1400 survey hours over the entirety of his/her career, including at least 40 survey hours in the past 12 months, and has completed or developed the classroom camera operator training as defined in Section 10.2.1. Previous 12 months means the 365-calendar days prior to the day of the activity that requires a senior OGI camera operator. The survey hours spent by the senior OGI camera operator performing comparative monitoring, either as part of initial training, retraining, or auditing other OGI camera operators, can be included when determining the senior OGI camera operator's experience both over his/her career and the past 12 months.

Simple scene is defined as a scene that contains 10 or fewer components in the field of view.

Survey hour is 60 minutes of observation conducted with an OGI camera. Survey hours do not include periods of time when the OGI camera operator is on a rest break. The 60 minutes do not need to be consecutive but are cumulative.

4.0 Interferences

4.1 Interferences from atmospheric conditions can impact the operator's ability to detect gas leaks. It is recommended that conditions involving steam, fog, mist, rain, solar glint, high particulate matter concentrations, and extremely hot backgrounds are avoided for a survey of acceptable quality.

5.0 Safety

5.1 Site Hazards. Prior to applying this protocol in the field, the potential hazards at the survey site should be considered; advance coordination with the site is critical to understand the conditions and applicable safety policies. Users should be aware of safety concerns with viewing equipment through a camera while walking around an industrial setting. Users should also be aware of hazards related to eye strain, eye fatigue, and mental fatigue that may occur from prolonged periods of viewing equipment with an OGI camera. This protocol does not address all of the safety concerns associated with its use. It is the responsibility of the user of this protocol to establish appropriate health and safety practices and determine the applicability of regulatory limitations prior to implementing this protocol.

5.2 Hazardous Pollutants. Several of the compounds encountered over the course of implementing this protocol may be irritating or corrosive to tissues (e.g., heptane) or may be toxic (e.g., benzene, methyl alcohol, hydrogen sulfide). Nearly all are fire hazards. Chemical compounds in gaseous emissions should be determined from process knowledge of the source. Appropriate precautions can be found in reference documents, such as reference 13.1.

6.0 Equipment and Supplies

6.1 An OGI camera model meeting the following specifications is required. This testing can be performed by the owner or operator, the camera manufacturer, or a third party. As required by Section 8.1, this testing must be performed initially, prior to using the OGI camera to conduct surveys. The determination in Section 6.1.1 must also be made any time the OGI camera will be used to survey components on equipment that was not previously included in monitoring surveys or whenever there are process changes that are expected to cause the gaseous emissions composition to change. The determination in Section 6.1.2 is only required initially and is required for each camera operating mode (e.g., standard versus high sensitivity or enhanced).

6.1.1 The spectral range of infrared radiation measured by the OGI camera must overlap with a major absorption peak for the chemical target of interest, meaning the OGI camera must be sensitive with a response factor of at least 0.25 when compared to the response factor of propane for the majority of constituents (>75 percent by volume) of the expected gaseous emissions composition.

6.1.2 The OGI camera must be capable of detecting (or producing a detectable image of) methane emissions of 19 grams per hour (g/hr) and either n-butane emissions of 29 g/hr or propane emissions of 22 g/hr at a viewing distance of 2.0 meters and a delta-T of 5.0 °C in an environment of calm wind conditions around 1 meter per second (m/s) or less, unless the referencing subpart provides detection rates for a different compound(s) for that subpart.

6.2 The following items are needed for the initial specification confirmation of each OGI camera model, as required by Sections 6.1.2, and development of operating envelopes, as required by Section 8:

6.2.1 Methane test gas, chemically pure grade (99.5 percent) or higher.

6.2.2 n-Butane test gas or propane test gas, chemically pure grade (99 percent) or higher.

6.2.3 Release orifice, ¼ inch (64 millimeter) inner diameter.

6.2.4 Mass flow controller or rotameter, capable of controlling the gas emission rate within an accuracy of 5 percent and traceable to the International System of Units (SI) through an unbroken chain of comparisons, i.e., calibrations.

6.2.5 An industrial fan, capable of adjusting the sustained nominal wind speeds at regular intervals, with the ability to maintain a spatially uniform set speed within 20 percent of the target wind speed over the area of detection.

6.2.6 A meteorological station capable of providing representative data on ambient

temperature, ambient pressure, relative humidity, and wind speed and direction at least once every hour. Follow the calibration and standardization requirements for meteorological measurements in EPA-454/B-08-002 (incorporated by reference, see § 60.17). The equipment must meet the following minimum specifications:

6.2.6.1 Ambient temperature readings accurate to at least 0.50 °C, with a resolution of 0.10 °C or less, and a minimum range of -20 to 70 °C.

6.2.6.2 Ambient pressure readings accurate to at least 5.0 millibar (mbar), with a resolution of 1.0 mbar or less, and a minimum range of 700 to 1100 mbar.

6.2.6.3 Wind speed readings accurate to at least 1.0 m/s, with a resolution of 0.10 m/s or less, and a minimum range of 0.10 to 20 m/s.

6.2.6.4 Wind direction readings accurate to at least 5 degrees, with a resolution of 1 degree or less.

6.2.6.5 Relative humidity readings accurate to at least 5.0 percent, with a resolution of 0.50 percent or less, and a minimum range of 10 to 90 percent noncondensing.

6.2.7 A temperature-controlled background large enough for viewing the emissions plume and capable of maintaining a uniform temperature. Uniform is defined as all points on the background deviating no more than 1.0 °C from the average temperature of the background.

6.2.8 T-type probe thermocouple and readout, accurate to at 1.0 °C and traceable to the SI through an unbroken chain of comparisons, i.e., calibrations, for measuring the test gas at or near the point of release.

6.2.9 T-type surface skin thermocouple and readout, accurate to at 1.0 °C and traceable to the SI through an unbroken chain of comparisons, i.e., calibrations, for measuring the background immediately behind the test gas.

6.2.10 Device to measure the distance between the OGI camera and the release point (e.g., tape measure, laser measurement tool), accurate to at least 2.0 centimeters (cm), with a resolution of at least 1.0 cm and traceable to the SI through an unbroken chain of comparisons, i.e., calibrations.

7.0 Camera Calibration and Maintenance

7.1 The camera does not require routine calibration for purposes of gas leak detection but may require calibration if it is used for thermography (such as with ΔT determination features). Operators should follow manufacturer recommendations regarding maintenance and calibration, as appropriate.

8.0 Camera Specification Confirmation and Development of the Operating Envelope

8.1 Determine that the OGI camera meets the specifications in Section 6.1 prior to conducting surveys with the OGI camera. The determination in Section 6.1.1 must also be made any time the OGI camera will be used to survey components on equipment that was not previously included in monitoring surveys or whenever there are process changes that are expected to cause the gaseous emissions composition to

change. The determination in Section 6.1.2 is only required initially. The results of this determination must be documented.

8.2 Field conditions such as the viewing distance to the component to be monitored, wind speed, ambient air temperature, and the background temperature all have the potential to impact the ability of the OGI camera operator to detect a leak. It is important that the OGI camera has been tested under the full range of expected field conditions in which the OGI camera will be used.

8.3 An operating envelope must be established for field use of the OGI camera. Imaging must not be performed when the conditions are outside of the developed operating envelope.

8.3.1 The operating envelope is specific to each model of OGI camera. The operating envelope can be developed by the owner or operator, the camera manufacturer, or a third party. The operating envelope must be developed initially, prior to conducting surveys with the OGI camera. The operating envelope may be updated or expanded at any time, following the procedures in this section.

8.3.2 The operating envelope must be confirmed for all potential configurations that could impact the detection limit, such as high sensitivity modes, available lenses, and handheld versus tripod. Conversely, separate operating envelopes may be developed for different configurations. If, in addition to or in lieu of the display on the camera itself, an external device (*e.g.*, laptop, tablet) is intended to be used to visualize the leak in the field, the operating envelope must be developed while using the external device. If the external device will not be used at all times, use of the external device is considered a separate configuration, and the operating envelope testing must be performed for both configurations.

8.4 Development of the operating envelope is to be performed using the test gas composition, flow rate, and orifice diameter described in Section 6.1.2, and must include the following variables:

8.4.1 Delta-T, regulated through the use of a temperature-controlled background encompassing approximately 50 percent of the field of view, with no potential for solar interference;

8.4.2 Viewing distance from the OGI camera to the component being imaged; and

8.4.3 Wind speed, controlled through the use of an industrial fan.

8.5 Determine the operating envelope using the following procedure:

8.5.1 Set up the methane test gas at a flow rate of 19 g/hr.

8.5.2 For this flow rate, the ability of the OGI camera to produce an observable image is challenged by ranges of the variables in Sections 8.4.1 through 8.4.3.

8.5.3 A panel of no less than 4 observers who have been trained using the OGI camera and who have a demonstrated capability of detecting gaseous leaks will observe the test gas release for each combination of delta-T, distance, and wind speed. A test emission is determined to be observed when at least 75 percent of the observers (*i.e.*, 3 of the 4 observers) see the image.

8.5.4 Repeat the procedures in Sections 8.5.2 and 8.5.3 using either an n-butane test gas at a flow rate of 29 g/hr or a propane test gas at a flow rate of 22 g/hr.

8.5.5 The operating envelope to be used in the field for each OGI camera configuration tested is the more restrictive operating envelope developed between the two test gases.

8.5.6 Repeat the procedures in Sections 8.5.1–8.5.5 for each camera configuration that will be used to conduct surveys in the field.

8.6 The results of the testing to establish the operating envelope, including supporting videos, must be documented.

8.7 If an operating envelope has not been developed for an OGI camera model or an OGI camera operator wants to expand an operating envelope to account for site-specific conditions, a daily field check for maximum viewing distance must be completed prior to conducting a monitoring survey. This daily field check for maximum viewing distance does not need to be performed if an OGI survey will be conducted within an operating envelope developed according to Sections 8.3 through 8.6.

8.7.1 A complete video record of the daily field check must be retained with the OGI survey records.

8.7.2 Each OGI camera operator who will conduct the monitoring survey must complete their own daily field check for maximum viewing distance using the OGI camera they will use to complete the monitoring survey. The daily field check must be conducted for each camera configuration that will be used during the monitoring survey.

8.7.3 The daily field check must be performed using the test gas composition and orifice diameter described in Section 6.1.2.

8.7.4 The daily field check must be conducted first for methane at a flow rate of 19 g/hr and then for either n-butane at a flow rate of 29 g/hr or propane at a flow rate of 22 g/hr. You must use a flow meter with a minimum accuracy of 5 percent of the mass rate. The daily field check for the two gases must occur at the same delta-T and wind speed conditions.

8.7.5 The OGI camera operator must determine the maximum distance from the gas release point at which the operator is able to visualize the gas release with the OGI camera. The OGI camera operator must document this distance, as well as the delta-T and the wind speed at the time of the daily field check and include this information with the OGI survey records.

8.7.6 If the daily check results in different maximum viewing distances for methane and n-butane/propane, the maximum viewing distance for the day for the OGI camera operator will be the shorter of the two maximum viewing distances.

8.7.7 If the delta-T in the field decreases below the delta-T that was recorded for the daily field check or if the wind speed increases above the wind speed recorded for the daily field check, the maximum viewing distance determination must be repeated for the new delta-T and wind speed conditions.

8.7.8 If multiple camera configurations will be used during the monitoring survey, the OGI camera operator may use the shortest

maximum viewing distance of any configuration for all the configurations that will be used during the survey, or the OGI camera operator may use a different maximum viewing distance for each configuration that will be used during the survey.

9.0 Conducting the Monitoring Survey

Each site must have a monitoring plan that describes the procedures for conducting a monitoring survey. One monitoring plan can be used for multiple sites, as long as the plan contains the relevant information for each site. At a minimum, the monitoring plan must include the elements in this section.

9.1 The monitoring plan must include a description of a daily verification check to be performed prior to imaging to confirm that the camera is operating properly. This verification must consist of the following at a minimum:

9.1.1 Confirm that the OGI camera software loads successfully and does not display any error messages upon startup;

9.1.2 Confirm that the OGI camera focuses properly at the shortest and longest distances that will be imaged;

9.1.3 Confirm that the OGI camera produces a live IR image using a known emissions source, such as a butane lighter or a propane cylinder;

9.1.4 Confirm that the OGI camera can perform the delta-T check function as expected if this function will be used to meet the requirement in Section 9.2.3.

9.2 The monitoring plan must include a procedure for ensuring that the monitoring survey is performed only when conditions in the field are within the operating envelope established in Section 8 or the conditions established by the daily field check in Section 8.7. This procedure must include the following:

9.2.1 If the OGI camera operator will use an operating envelope established under Section 8, a description of how the viewing distance from the surveyed components, the wind speed, and the delta-T will be monitored and how the operator will deal with changes in site conditions during the survey to ensure that the monitoring survey is conducted within the limits of the operating envelope;

9.2.2 If the OGI camera operator performs a daily field check according to Section 8.7, a description of how the OGI camera operator will monitor viewing distance to ensure the viewing distance is less than the daily maximum viewing distance and how the OGI camera operator will monitor the delta-T and wind speed to ensure the delta-T remains above and the wind speed remains below those that occurred during the daily field check;

9.2.3 Description of how the operator will ensure an adequate delta-T is present in order to view potential gaseous emissions, *e.g.*, using a delta-T check function built into the features of the OGI camera or using a background temperature reading in the OGI camera field of view;

9.2.4 Description of how the operator will recognize the presence of and deal with potential interferences and/or adverse monitoring conditions, such as steam, fog,

mist, rain, solar glint, extremely high concentrations of particulate matter, and hot temperature backgrounds.

9.3 The site must conduct monitoring surveys using a methodology that ensures that all the components regulated by the referencing subpart within the unit or area are monitored. This must be achieved using one of the following three approaches or a combination of these approaches. The approach(es) chosen and how the approach(es) will be implemented must be described in the monitoring plan.

9.3.1 Use of a route map or a map with designated observation locations. The map must be included as part of the monitoring plan, with a predetermined sequence of process unit monitoring (such as directional arrows along the monitoring path) depicted or designated observation locations clearly marked.

9.3.2 Use of visual cues. The facility must develop visual cues (e.g., tags, streamers, or color-coded pipes) to ensure that all components regulated by the referencing subpart were monitored. The monitoring plan must describe what visual cue method is used and how it will be used to ensure all components are monitored during the survey.

9.3.3 Use of global positioning system (GPS) route tracing. The facility must document the path taken during the survey by capturing GPS coordinates along the survey path, along with date and time stamps. These locations should be identified by latitude and longitude coordinates in decimal degrees to an accuracy and precision of at least five decimals of a degree using the North American Datum of 1983. GPS coordinates must be recorded frequently enough to document that all components regulated by the referencing subpart were monitored. The monitoring plan must describe how often GPS coordinates will be recorded and how the route tracing will ensure all components regulated by the referencing subpart are monitored.

9.4 The monitoring plan must include a procedure that describes how components will be viewed with the OGI camera.

9.4.1 Components must be imaged from at least two different angles.

9.4.2 For a simple scene, which is a scene that contains 10 or fewer components in the field of view, the OGI camera operator must have a minimum dwell time on each angle of 10 seconds per scene before changing the angle, distance, or focus and dwelling again.

9.4.3 For scenes other than simple scenes, the operator must divide the scene into manageable subsections. The OGI camera operator must have a minimum dwell time of 2 seconds per component in the field of view for each angle.

9.4.4 It may be necessary to reduce distance or change angles in order to reduce the number of components in the field of view. An OGI camera operator may choose to reduce the distance from components in order to create simple scenes.

9.4.5 The required dwell times stated in this section are minimum dwell times. Additional dwell time may be necessary to assess whether each monitored component is leaking or not leaking. OGI camera operators should use training and knowledge of

environmental conditions and component configurations to increase dwell time where appropriate.

9.4.6 The dwell time is the time that the OGI camera is in a particular operating mode and the scene is in focus and held steady such that an OGI camera operator is able to monitor for leaks. Changing OGI camera operating modes or viewing angles requires the OGI camera operator to restart the dwell time.

9.4.7 The procedure must discuss changes, if necessary, to the imaging mode of the OGI camera that are appropriate to ensure that leaks from all components regulated by the referencing subpart can be imaged.

9.5 The monitoring plan must include a plan for avoiding camera operator fatigue, as physical, mental, and eye fatigue are concerns with continuous field operation of OGI cameras. The OGI camera operator should not survey continuously for a period of more than 30 minutes without taking a rest break. Taking a rest break between surveys of process units may satisfy this requirement; however, for process units or complex scenes requiring continuous survey periods of more than 30 minutes, the operator must take a break of at least 5 minutes after every 30 minutes of surveying. Operators can complete tasks related to the monitoring survey, such as documentation, during the 5-minute rest break, so long as the operator is not actively imaging components.

Note: If continuous surveying is desired for extended time periods, two camera operators can alternate between surveying and taking breaks.

9.6 The monitoring plan must include a procedure for documenting monitoring surveys. The information documented must include:

9.6.1 The name of the facility, date, and approximate start and end times for each monitoring survey.

9.6.2 The weather conditions, including ambient temperature, wind speed, relative humidity, and sky conditions at the start and end of each monitoring survey. For monitoring surveys conducted for more than four hours, record the weather conditions every two hours.

9.7 The site must have a procedure for documenting fugitive emissions or leaks found during the monitoring survey.

9.7.1 If a leak is found, capture either a short video clip or photograph of the component associated with the leak. If the leak is not immediately repaired, the leaking component must be tagged for repair. The date, time, location of the leak, and an identification of the component associated with the leak must be recorded and stored with the OGI survey records. A full recording of the survey will suffice for this requirement.

9.7.2 If no emissions are found, no recorded footage is required to demonstrate that the component was not leaking.

9.8 The monitoring plan must include a quality assurance (QA) verification video for each OGI operator at least once each monitoring day. The QA verification video must be a minimum of 5 minutes long and document the procedures the operator uses to survey (e.g., dwell times, angles, distances, backgrounds) and the camera configuration.

9.9 The monitoring plan must describe the process that will be used to ensure the validity of the monitoring data as detailed in Section 11.

10.0 Camera Operator Training

10.1 The facility or company performing the OGI surveys must have a training plan which ensures and monitors the proficiency of the camera operators. Training should include classroom instruction and field training on the OGI camera and external devices, monitoring techniques, best practices, process knowledge, and other regulatory requirements related to leak detection that are relevant to the facility's OGI monitoring efforts. If the facility does not perform its own OGI monitoring, the facility must ensure that the training plan for the company performing the OGI surveys adheres to this requirement.

10.2 Prior to conducting monitoring surveys, camera operators must complete initial training and demonstrate proficiency with the OGI camera and any external devices to be utilized for detecting a potential leak.

10.2.1 At a minimum, the training plan must include the following classroom training elements as part of the initial training. Classroom training can be conducted at a physical location, remotely, or online.

10.2.1.1 Key fundamental concepts of the OGI camera technology, such as the types of images the camera is capable of visualizing and the technology basis (theory) behind this capability.

10.2.1.2 Parameters that can affect image detection (e.g., wind speed, temperature, distance, background, and potential interferences).

10.2.1.3 Description of the components to be surveyed and example imagery of the various types of leaks that can be expected.

10.2.1.4 Operating and maintenance instructions for the OGI camera used at the facility.

10.2.1.5 Procedures for performing the monitoring survey according to the monitoring plan, including the daily verification check; how to ensure the monitoring survey is performed only when the conditions in the field are within the established operating envelope; the number of angles a component or set of components should be imaged from; the minimum dwell time for a scene before changing the angle, distance, and/or focus; how to improve the background visualization; the procedure for ensuring that all components regulated by the referencing subpart are visualized; and required rest breaks.

10.2.1.6 Recordkeeping requirements.

10.2.1.7 Common mistakes and best practices.

10.2.1.8 Discussion of the regulatory requirements related to leak detection that are relevant to the facility's OGI monitoring efforts.

10.2.2 At a minimum, the training plan must include the following field training elements as part of the initial training:

10.2.2.1 A minimum of 3 survey hours with OGI where trainees observe the techniques and methods of a senior OGI

camera operator (see definition in Section 3.0) who reinforces the classroom training elements.

10.2.2.2 A minimum of 12 survey hours with OGI where the trainee performs the initial OGI survey with a senior OGI camera operator verifying the results by conducting a side-by-side comparative survey and providing instruction/correction where necessary.

10.2.2.3 A minimum of 15 survey hours with OGI where the trainee performs monitoring surveys independently with a senior OGI camera operator present and the senior OGI camera operator providing oversight and instruction/correction to the trainee where necessary.

10.2.2.4 A final monitoring survey test where the trainee conducts an OGI survey of at least 2 survey hours and a senior OGI camera operator follows behind with a second camera to confirm the OGI survey results. If there are 10 or more leaks identified by the senior OGI operator, the trainee must achieve no more than 10 percent missed persistent leaks relative to the senior OGI camera operator to be considered authorized for independent survey execution. If there are less than 10 leaks identified by the senior OGI operator, the trainee must achieve zero missed persistent leaks relative to the senior OGI camera operator to be considered authorized for independent survey execution.

10.2.2.5 If the trainee doesn't pass the monitoring survey test in Section 10.2.2.4, the senior OGI operator must discuss the reasons for the failure with the trainee and provide instruction/correction on improving the trainee's performance. Following the discussion with the senior OGI operator, the trainee may repeat the test in Section 10.2.2.4.

10.3 All OGI camera operators must attend a biennial classroom training refresher. This refresher can be shorter in duration than the initial classroom training but must cover all the salient points necessary to operate the camera (*e.g.*, performing surveys according to the monitoring plan, best practices, discussion of lessons learned). Refresher training can be conducted at a physical location, remotely, or online.

10.4 Performance audits for all OGI camera operators must occur on a semiannual basis with at least three months between two consecutive audits. Performance audits must be conducted according to one of the following procedures:

10.4.1 Performance audit by comparative monitoring. Comparative monitoring in near real-time is where a senior OGI camera operator reviews the performance of the employee being audited by performing an independent monitoring survey.

10.4.1.1 Following a survey conducted by the camera operator being audited, the senior OGI camera operator will conduct a survey of at least 2 survey hours in the same area to ensure that no persistent leaks were missed.

10.4.1.2 If there are 10 or more leaks identified by the senior OGI operator, the camera operator being audited must achieve no more than 10 percent missed persistent leaks relative to the senior OGI camera operator. If there are less than 10 leaks identified by the senior OGI operator, the camera operator being audited must achieve zero missed persistent leaks relative to the senior OGI camera operator. If the camera operator being audited does not achieve this benchmark, then the camera operator being audited will need to be retrained as outlined in Section 10.4.3.

10.4.2 Performance audit by video review. The camera operator being audited must submit unedited and uncut video footage of their OGI survey technique to a senior OGI camera operator for review.

10.4.2.1 The videos must contain at least 2 survey hours of survey footage. If a single monitoring survey is less than 2 survey hours, footage from multiple monitoring surveys may be submitted; however, all videos necessary to cover a 2-hour period must be recorded and submitted for review. The senior OGI camera operator will review the survey technique of the camera operator being audited, as well as look for any missed leaks.

10.4.2.2 If the senior OGI camera operator finds that the survey techniques during the video review do not match those described in the monitoring plan, then the camera operator being audited will need to be retrained as outlined in Section 10.4.3. Additionally, if there are 10 or more leaks identified by the senior OGI operator, the camera operator being audited must achieve no more than 10 percent missed persistent leaks relative to the senior OGI camera operator. If there are less than 10 leaks identified by the senior OGI operator, the camera operator being audited must achieve zero missed persistent leaks relative to the senior OGI camera operator. If the camera operator being audited does not achieve this benchmark, then the camera operator being audited will need to be retrained as outlined in Section 10.4.3.

10.4.3 At a minimum, retraining must consist of the following elements:

10.4.3.1 A discussion of the reasons for the failure with the OGI operator being audited and techniques to improve performance.

10.4.3.2 A minimum of 8 survey hours with OGI where the trainee performs the initial OGI survey with a senior OGI camera operator verifying the results by conducting a side-by-side comparative survey and providing instruction/correction where necessary.

10.4.3.3 A minimum of 8 survey hours with OGI where the trainee performs the survey independently with the senior OGI camera operator trainer present and the senior OGI camera operator provides oversight and instruction/correction to the trainee where necessary.

10.4.3.4 The audited camera operator must perform a final monitoring survey test

as described in Section 10.2.2.4 and meet the requirements in Section 10.2.2.4 to be recertified.

10.4.4 If an OGI operator requires retraining in two consecutive semiannual audits, the OGI operator must repeat the initial training requirements in Section 10.2.

10.4.5 If a camera operator is not scheduled to perform an OGI survey during a semiannual period, then the audit must occur with the next scheduled monitoring survey.

10.5 If an OGI camera operator has not conducted a monitoring survey in over 12 months, then the operator must complete the retraining requirements in Section 10.4.3 prior to conducting surveys. If an OGI camera operator has not conducted a monitoring survey in over 24 months, then the operator must complete the biennial classroom training in Section 10.3 and complete the retraining requirements in Section 10.4.3 prior to conducting surveys.

10.6 Previous experience with OGI camera operation can be substituted for some of the initial training requirements in Section 10.2 as outlined in this Section 10.6.1 and 10.6.2.

10.6.1 OGI camera operators with previous classroom training (at a physical location, remotely, or online) that included a majority of the elements listed in Section 10.2.1 do not need to complete the initial classroom training as described in Section 10.2.1, but if the date of training is more than two years before March 8, 2024, the biennial classroom training in Section 10.3 must be completed in lieu of the initial classroom training in Section 10.2.1.

10.6.2 OGI camera operators who have 40 survey hours of experience over the 12 calendar months prior to March 8, 2024 may substitute the retraining requirements in Section 10.4.3, including the final monitoring survey test, for the initial field training requirements in Section 10.2.2.

11.0 Quality Assurance and Quality Control

11.1 As part of the facility's monitoring plan, the facility must have a process which ensures the validity of the monitoring data. Examples may include routine review and sign-off of the monitoring data by the camera operator's supervisor, periodic comparative monitoring using a different camera operator as part of a continuing training verification plan described in Section 10, or other due diligence procedures.

11.2 For each monitoring day, the daily OGI camera verification must be performed as described in Section 9.1. Additionally, the daily QA verification video for each operator must be recorded as described in Section 9.8 for each operator for each monitoring day.

11.3 The following table is a summary of the mandatory QA and quality control (QC) measures in this protocol with the associated frequency and acceptance criteria. All of the QA/QC data must be documented and kept with other OGI records.

SUMMARY TABLE OF QA/QC

Parameter	QA/QC specification	Acceptance criteria	Frequency
OGI Camera Design	Spectral bandpass range.	Must overlap with major absorption peak of the compound(s) of interest.	Once initially (prior to using the OGI camera to conduct surveys), when survey components on equipment that was not previously included in monitoring surveys, whenever there are process changes that are expected to cause the gaseous emissions composition to change.
OGI Camera Design	Initial camera specification confirmation.	Must be capable of detecting (or producing a detectable image of) methane emissions of 19 g/hr and either n-butane emission of 29 g/hr or propane emissions of 22 g/hr at a viewing distance of 2.0 meters and a delta-T of 5.0 °C in an environment of calm wind conditions around 1.0 m/s or less.	Once initially (prior to using the OGI camera to conduct surveys).
Developing the Operating Envelope.	Observation confirmation.	Leak is observed by 3 out of 4 panel observers for specific combinations of delta-T, distance, and wind speed.	Once initially (prior to using the OGI camera to conduct surveys) and prior to using a new camera configuration for which an envelope was not previously established. The operating envelope may be updated or expanded at any time, following the procedures in Section 8.
Daily Field Check	Maximum viewing distance.	Determine distance at which each OGI camera operator can visualize leaks according to Section 8.7.	Each monitoring day. Not required for OGI camera operators using operating envelopes established according to Section 8.
OGI Camera Functionality.	Verification Check	Meet the requirements of Section 9.1 to confirm that the OGI camera software loads successfully and that the camera focuses properly, produces a live IR image, and, as applicable, performs the delta-T check function.	Each monitoring day, prior to conducting a survey.
Camera Operator Training.	Classroom training	Meet the requirements of Sections 10.2.1 and 10.3 with the issuing of a certificate or record of attendance.	Prior to conducting surveys (except as noted in Section 10.6.1), with a biennial refresher.
Camera Operator Training.	Field training	Meet the requirements of Section 10.2.2 while maintaining the records of survey hours by the trainee along with a certificate or record of completion issued upon passing the final monitoring survey test in Section 10.2.2.4 with the date of the survey recorded.	Except as noted in Section 10.6.2, prior to conducting surveys and if retraining is required following two consecutive semi-annual audits.
OGI Camera Operator Performance.	Semiannual performance audits.	Comparative monitoring or video review. Meet the benchmarks in Section 10.4.1.2 or 10.4.2.2.	Every 6 months, with at least 3 months between consecutive audits or at the next scheduled monitoring survey if a camera operator is not scheduled to perform an OGI survey during the semiannual period.
Camera Operator Training.	Field retraining	Meet the requirements of Section 10.4.3 while maintaining the records of survey hours by the trainee along with a certificate or record of completion issued upon passing the final monitoring survey test in Section 10.2.2.4 with the date of the survey recorded.	After failing to meet the benchmarks in Section 10.4.1.2 or 10.4.2.2 during a semi-annual audit or after a prolonged period (greater than 12 months) of not performing OGI surveys. May be substituted for initial field training as noted in Section 10.6.2.
OGI Camera Operator Performance.	QA verification video ..	Record a video that is a minimum of 5 minutes long that documents the procedures the operator uses to survey (e.g., dwell times, angles, distances, backgrounds) and the camera configuration.	Each monitoring day.

12.0 Recordkeeping

12.1 Records must be kept for a period of 5 years, unless otherwise noted below or otherwise specified in a referencing subpart. Records may be retained in hard copy or electronic form.

12.2 The facility must maintain the following records in a manner that is easily accessible to all OGI camera operators. These records must be retained for as long as the site performs OGI surveys. Older versions of

these records that are no longer relevant because they have been replaced by newer versions must be retained for a period of 5 years past the date on which they are replaced.

12.2.1 Complete site monitoring plan with all the required elements.

12.2.2 The OGI camera operating envelope limitations.

12.3 All data supporting the OGI camera specification confirmation (initially and updated as required in Section 8.1) and

development of the operating envelope. While the owner or operator does not need to have a copy of these records onsite if another entity performed the camera specification confirmation or development of the operating envelope, the owner or operator must:

(1) Ensure that the camera specification confirmation and development of the operating envelope were performed in accordance with the requirements of this appendix K,

(2) Ensure easy access to these records, and
(3) Make the records available for review if requested by the Administrator.

These records must be retained for the entire period that the OGI camera is used to conduct surveys at the site plus 5 years.

12.4 The training plan for OGI camera operators. The plan must be retained for as long as the site performs OGI surveys. Older versions of the plan that are no longer relevant because they have been replaced by a newer version must be retained for a period of 5 years past the date on which they are replaced. If the facility does not perform its own OGI monitoring, the owner or operator must:

(1) Ensure that the training plan for the company performing the OGI surveys adheres to the requirements of this appendix K,

(2) Ensure easy access to the plan, and

(3) Make the plan available for review if requested by the Administrator.

12.5 For each OGI camera operator, the following records. These may be kept in a separate location for privacy but must be easily accessible to program administrators and available for review if requested by the Administrator. It may be necessary to retain the records in Section 12.5.3 for longer than 5 years to show the career experience survey hours for senior OGI camera operators. If the facility does not perform its own OGI monitoring, the owner or operator must:

(1) Ensure that the training plan for the company performing the OGI surveys adheres to the requirements of this appendix K,

(2) Be able to easily access these records, and

(3) Make the records available for review if requested by the Administrator.

The records must include the following information.

12.5.1 The date of completion of initial OGI camera operator classroom training;

12.5.2 The date of the passed final site survey test following the initial OGI camera operator field training or retraining;

12.5.3 The number and date of all surveys performed, and if the survey is part of initial field training or retraining, the amount of survey hours and notation of whether the survey was performed by observing a senior OGI camera operator, side-by-side with a senior OGI camera operator, or with oversight from a senior OGI camera operator;

12.5.4 The date and results of semiannual performance audits;

12.5.5 The date of the biennial classroom training refresher; and

12.5.6 Documentation to support the use of previous experience as a substitution for initial training requirements, including the date of previous classroom training and documentation of survey hours over the 12 calendar months prior to March 8, 2024, as appropriate.

12.6 Monitoring survey results shall be kept in a manner that is accessible to those technicians executing repairs and at a minimum must contain the following:

12.6.1 Daily verification check;

12.6.2 Identification of the site surveyed, the survey date, and the start and end times of the survey;

12.6.3 Name of the OGI camera operator performing the survey and identification of the OGI camera used to conduct the survey. The identification of the OGI camera can be the serial number or an assigned name/number labeled on the camera, but it must allow an operator or inspector to tie the camera back to the records associated with the camera (e.g., maintenance, initial specification confirmation);

12.6.4 Weather conditions, including the ambient temperature, wind speed, relative humidity, and sky conditions, at the start and end of the survey and every two hours (if the survey exceeded four hours in length);

12.6.5 Video footage or photograph of any leak detected, or video footage of the entire survey, along with the date, time, and location of the leak, and identification of the component associated with the leak;

12.6.6 The daily QA verification video for each operator; and

12.6.7 GPS coordinates for the route taken, if Section 9.3.3 is used to ensure all components regulated by the referencing subpart are monitored.

12.7 For each instance that an OGI camera operator uses the daily field check outlined in Section 8.7 instead of an operating enveloped established under Section 8, the following records must be kept with the monitoring survey records required by Section 12.6.

12.7.1 Date and time of each daily field check.

12.7.2 Video record of the daily field check.

12.7.3 Maximum viewing distance determined for each test gas in each configuration for each OGI camera operator. The overall maximum viewing distance (or overall maximum viewing distance per configuration) that will be used for the monitoring day for each OGI camera operator.

12.7.4 The delta-T and wind speed at the time of the daily field check.

12.7.5 Documentation of the test gas flow rate and concentrations during the daily field check.

12.8 Camera maintenance and calibration records over the entire period that the OGI camera is used to conduct surveys at the site. Older versions of these records that are no longer relevant because they have been replaced by newer versions must be retained for a period of 5 years past the date on which they are replaced. If the facility does not perform its own OGI monitoring, the owner or operator must be able to easily access these records and must make the records available for review if requested by the Administrator.

13.0 References

13.1 U.S. Department of Health and Human Services. (2010). NIOSH Pocket Guide to Chemical Hazards. NIOSH Publication No. 2010-168c. Also available from <https://www.cdc.gov/niosh/docs/2010-168c/default.html>.

13.2 U.S. Environmental Protection Agency. (2023). Technical Support Document: Optical Gas Imaging Protocol (Appendix K to this part).

13.3 U.S. Environmental Protection Agency. (2020). Optical Gas Imaging

Stakeholder Input Workshop Presentations and Discussion; Summary Letter Report.

13.4 Zimmerle, D., T. Vaughn, C. Bell, K. Bennett, P. Deshmukh, and E. Thoma. (2020). Detection Limits of Optical Gas Imaging for Natural Gas Leak Detection in Realistic Controlled Conditions. *Environmental Science & Technology*, 54(18), 11506–11514. DOI: 10.1021/acs.est.0c01285.

14.0 Annexes

14.1 Annex 1—Development of Response Factors for OGI Cameras.

14.1.1 Introduction.

The purpose of this annex 14.1 is to outline the protocol for the development of response factors (RFs) for optical gas imaging (OGI) cameras. As defined in Section 3.0 of this appendix K, a response factor is the OGI camera's response to a compound of interest relative to a reference compound at a concentration path-length of 10,000 parts per million-meter (ppm-m).

14.1.1.1 Nomenclature.

14.1.1.1.1 The definitions listed in Section 3.0 of this appendix K apply to this annex 14.1.

14.1.1.1.2 Infrared (IR) radiance pixel area. The IR radiance pixel area is the average of a set of pixel IR radiance for an instantaneous measurement. There will be three different areas representing the reference cell, gas cell, and the raw blackbody surface. The pixel count for each area must be at a minimum of 0.5 percent of the total pixels of the detector. The pixel locations selected for an area must not change throughout the test.

14.1.1.1.3 Measurement data set.

Measurement data set is the number of time independent IR radiance pixel areas that are taken. The minimum number of measured IR radiance pixel area within a data set is 1,000 data points. The number of measured IR radiance pixel area within a measurement data set should stay consistent throughout the test.

14.1.1.1.4 Reference Compound. The reference compound is the compound that provides the reference for determination of the RF with the compound of interest. The reference compound for this annex 14.1 is propane, unless otherwise specified in a referencing subpart.

14.1.2 Applicability and Analytical Principle.

14.1.2.1 Applicability. This annex 14.1 applies to the determination of compound specific RFs through empirical testing for use with this appendix K. This annex 14.1 does not apply to other applications of OGI cameras or other instruments. This annex 14.1 does not limit the use of other peer reviewed and published techniques and RFs per Section 3.0 of this appendix K.

14.1.2.2 Analytical Principle. OGI cameras work by providing an image or video with each pixel representing a measurement of the IR radiation. OGI cameras limit measurement to specific wavelengths of IR through the choice of the detector and generally through the addition of a bandpass filter. Limiting the measurement to specific wavelengths of IR allows the OGI camera to focus on a specific region of interest in order to increase the detection capabilities of

particular compounds of interest. The combination of detector and bandpass filter, in addition to limiting the region of interest, will allow varying amounts of IR over the specific wavelength region.

14.1.3.0 Equipment and Supplies.

14.1.3.1 Section 6.0 of this appendix K lists equipment and supplies that may be used in this annex 14.1.

14.1.3.2 Blackbody Source. A sufficiently large blackbody source capable of maintaining high emissivity, as well as temperature stability and homogeneity.

14.1.3.2.1 The blackbody must have an emissivity of 0.95 or higher in the IR region of interest.

14.1.3.2.2 The source emissive area must have a uniform temperature, where uniform is defined as all points on the emissive area deviating no more than 0.10 degree Celsius ($^{\circ}\text{C}$) from the average temperature of the emissive area. The temperature readings must be accurate to at least 0.10 $^{\circ}\text{C}$. The blackbody must be able to maintain its temperature within 0.10 $^{\circ}\text{C}$.

14.1.3.2.3 The source's surface area must be large enough to allow the OGI camera to take IR measurements of two gas cells and allow for the proper measurement of IR radiance through the gas and reference cell and IR radiance of the surface itself.

14.1.3.3 Test gas for each compound of interest, used for determining the RF. The concentration of the gas in the cylinder must be vendor certified to ± 5.0 percent of the cylinder tag value and be in a balance of nitrogen. The concentration of the gas must be such that the gas cell concentration is 10,000 ppm-m with less than 2.0 percent error. Alternatively, the gas standard may be produced with dilution per Method 205 of 40 CFR part 51 Appendix M with the exception that the mid-supply gas may be vendor certified to ± 5.0 percent of the cylinder tag value.

14.1.3.4 Gas Cell. A windowed gas cell that is leak tight and has the ability to flow gas through the cell. The size of the cell should be such to allow for 10,000 ppm-m to be viewed by the OGI camera with less than 2.0 percent error. The windows should be 99 percent transmissive in the IR region of interest and deviate no more than 0.50 percent transmission over than region of interest. The cell must have associated temperature, flow, and pressure measurements.

14.1.3.5 Reference Compound Gas Standard. Propane gas standard, unless a referencing subpart specifies otherwise, used as the reference for determination of the RF. The concentration of the gas in the cylinder must be vendor certified to ± 2.0 percent of the cylinder tag value and be in a balance of nitrogen. The concentration of the gas must be such that the gas cell concentration is 10,000. ppm-m with less than 2.0 percent error.

14.1.3.6 Reference Cell. A gas cell for the reference compound gas standard which meets all of the requirements in Section 14.1.3.4 of this annex 14.1.

14.1.3.7 Zero Gas. A 99.99 percent pure diatomic gas, typically nitrogen, that has no IR response from the OGI camera, used to assess the detection level of the system and baseline response of the gas cells.

14.1.3.8 OGI Camera is the specific OGI camera that is being tested. RFs must be determined for each IR detector and bandpass filter combination. The OGI camera must have the ability to output the raw IR radiance at the pixel level.

14.1.3.8.1 The combination of IR detector and bandpass filter may be consistent over several models such that the developed RFs may be applicable to more than one model of OGI camera.

14.1.3.8.2 If the OGI camera model has exchangeable bandpass filters, more than one set of RFs may be needed for the OGI camera model to account for the differences between filters.

4.0 Pre-Test Preparation and Evaluations.

14.1.4.1 Room Preparation. The room where testing will occur must be prepared by removing all extraneous thermal sources, or at a minimum, isolating extraneous thermal sources with IR absorptive material before any testing is conducted.

14.1.4.2 Reference and Gas Cell Preparation. Perform leak checks on both the reference and gas cells. Ensure that the temperatures of the cells are within 0.10 $^{\circ}\text{C}$ and that the pressure measurements are working.

14.1.4.3 OGI Camera Preparation. Ensure the OGI camera is operating to manufacturer specifications and able to record in raw IR radiance on a per pixel basis.

14.1.4.4 Blackbody Preparation and Verification. Prepare the blackbody by setting the temperature 10.0 $^{\circ}\text{C}$ different than the gas and reference cell temperatures. Ensure the blackbody is working correctly by verifying the IR radiance homogeneity of the blackbody surface with the OGI camera.

14.1.4.5 System Preparation. Ensure the alignment of the cells, blackbody source, and OGI camera are all fixed in place and cannot deviate from their position during the testing.

14.1.4.5.1 The reference and gas cell windows must overlap the blackbody surface in a manner that provides sufficient viewing of the blackbody surface from the vantage point of the camera.

14.1.4.5.2 The reference and gas cells should be placed sufficiently away from the blackbody surface. The distance must be far enough to ensure that the reference and gas cells are not heated or cooled by the blackbody surface.

14.1.4.5.3 The OGI camera should be located at a distance such that the field of view allows the requirements of the IR radiance pixel area to be met. Additionally, the distance must be such that it does not nominally change the path length of the cell.

14.1.4.5.4 For both the reference cell and the gas cell, the depth of the cell and concentration of the gas must result in a concentration 10,000. ppm-m with less than 2 percent error.

14.1.4.6 Initial System Assessment.

14.1.4.6.1 Flow zero gas through both the reference and gas cell, and ensure the gas cell temperatures are within 0.1 $^{\circ}\text{C}$.

14.1.4.6.2 Record the temperatures of the gas and reference cells, the blackbody surface, and the room. Record the pressures in the reference and gas cells. Record the flowrates into the reference and gas cells.

14.1.4.6.3 Measure the IR radiance of the reference cell, the gas cell, and the blackbody

surface for a measurement data set. For the IR radiance pixel area for the blackbody, the blackbody through the reference cell, and the blackbody through the gas cell, calculate the average, the standard deviation, and the 99 percent confidence level for the measurement data set.

14.1.4.6.4 The detection limit for the system will be the highest 99 percent confidence level of the IR radiance measurement of the blackbody, blackbody through the reference cell, or blackbody through the gas cell.

14.1.4.6.5 If the standard deviation of the reference cell's and the gas cell's average pixel areas of interest have a difference greater than 5 percent, take corrective actions and repeat the assessment.

14.1.5.0 Sampling and Analysis Procedure.

14.1.5.1 Flow reference compound gas through the reference cell and test gas for the compound of interest through the gas cell and ensure the cell temperatures are within 0.10 $^{\circ}\text{C}$.

14.1.5.2 Record the temperatures of the gas and reference cells, the blackbody surface, and the room temperature. Record the pressures in the reference and gas cells. Record the flowrates into the reference and gas cells. If using Method 205 of 40 CFR part 51 Appendix M for dilution of the test gas for the compound of interest, record the appropriate parameters required by the method.

14.1.5.3 Adjust the gas flow if the pressure in the cell is not within an inch of water of ambient pressure. Ensure cell temperatures are within 0.10 $^{\circ}\text{C}$ of the room temperature.

14.1.5.4 Measure the IR radiance of the reference cell, the gas cell, and the blackbody surface for a measurement data set. Calculate the average of the IR radiance pixel area and the standard deviation of the IR radiance pixel area for the reference cell, gas cell, and the blackbody surface for the measurement data set.

14.1.6.0 Post-test Requirements.

14.1.6.1 Post-test Assessment.

14.1.6.1.1 Flow zero gas through both the reference and gas cells and ensure the cell temperatures are within 0.1 $^{\circ}\text{C}$.

14.1.6.1.2 Record the temperatures of the gas and reference cells, the blackbody surface, and the room. Record the pressures in the reference and gas cells. Record the flowrates into the reference and gas cells.

14.1.6.1.3 Measure the IR radiance of the reference cell, the gas cell, and the blackbody surface for a measurement data set. Calculate the average of the IR radiance pixel area, and the 99 percent confidence level of the IR radiance pixel area for the reference cell, gas cell, and the blackbody surface for the measurement data set.

14.1.6.1.4 If the average and standard deviation of the reference cell's and the gas cell's average pixel areas of interest have a difference greater than 5.0 percent between the pre-test and post-test assessment, then the test is invalid. Take corrective actions and repeat the test.

14.1.6.2 When the average of the IR radiance pixel areas for the compound of

interest over the measurement set as determined in Section 14.1.5.4 of this annex

14.1 is greater than the detection limit established in Section 14.1.4.6.4 of this

annex 14.1, calculate the RF for the compound of interest as follows:

$$RF = \frac{I_{Blackbody} - (I_{Compound\ of\ Interest} - I_{Gas\ Cell})}{I_{Blackbody} - (I_{Reference\ Compound} - I_{Reference\ Cell})}$$

RF = response factor of the compound of interest (unitless).

$I_{Blackbody}$ = average of the IR radiance pixel areas for the blackbody over the measurement set as determined in Section 14.1.4.6.3 of this annex 14.1, $W \cdot m^{-2} \cdot sr^{-1}$ (watts per square meter per steradian).

$I_{Compound\ of\ interest}$ = average of the IR radiance pixel areas for the compound of interest over the measurement set as determined in Section 14.1.5.4 of this annex 14.1, $W \cdot m^{-2} \cdot sr^{-1}$.

$I_{Gas\ Cell}$ = average of the IR radiance pixel areas for the gas cell over the measurement set during the pre-test assessment as determined in Section 14.1.4.6.3 of this annex 14.1, $W \cdot m^{-2} \cdot sr^{-1}$.

$I_{Reference\ Compound}$ = average of the IR radiance pixel areas for the reference compound over the measurement set as determined in Section 14.1.5.4 of this annex 14.1, $W \cdot m^{-2} \cdot sr^{-1}$.

$I_{Reference\ Cell}$ = average of the IR radiance pixel areas for the reference cell over the measurement set during the pre-test

assessment as determined in Section 14.1.4.6.3 of this annex 14.1, $W \cdot m^{-2} \cdot sr^{-1}$.

14.1.6.3 When the average of the IR radiance pixel areas for the compound of interest over the measurement set as determined in Section 14.1.5.4 of this annex 14.1 is less than the detection limit established in Section 14.1.4.6.4 of this annex 14.1, the RF is equal to zero.

14.1.7.0 Reporting and Recordkeeping Requirements.

14.1.7.1 Records, including all raw data and calculations, must be kept for a period of 5 years, unless otherwise noted below or otherwise specified in a referencing subpart. Records may be retained in hard copy or electronic form.

14.1.7.2 All records supporting the development of RFs under this annex 14.1 must be maintained in a manner that is easily accessible to all OGI camera operators using the RFs. While the owner or operator does not need to have a copy of these records onsite if another entity performed the development of the RFs, the owner or operator must:

(1) Ensure that the RF development was performed in accordance with the requirements of this annex,

(2) Ensure easy access to these records, and
(3) Make the records available for review if requested by the Administrator.

These records must be retained for the entire period that the OGI camera is used to conduct surveys at the site plus 5 years. Previous versions of these records that are no longer relevant because they have been replaced by newer versions or because the specific OGI camera model is no longer being used to conduct surveys at the site must be retained for a period of 5 years past the date on which the records are replaced or the OGI camera model is no longer being used to conduct surveys at the site.

14.1.8.0 References.

14.1.8.1 U.S. Environmental Protection Agency. (2023). Technical Support Document: Optical Gas Imaging Protocol (appendix K to this part).

[FR Doc. 2024-00366 Filed 2-23-24; 4:15 pm]

BILLING CODE 6560-50-P



FEDERAL REGISTER

Vol. 89

Friday,

No. 47

March 8, 2024

Part III

Federal Aviation Administration

14 CFR Part 21

Airworthiness Criteria: Special Class Airworthiness Criteria for the Job
Aero, Inc. Model JAS4-1 Powered-Lift; Final Rule

DEPARTMENT OF TRANSPORTATION**Federal Aviation Administration****14 CFR Part 21**

[Docket No. FAA–2021–0638]

Airworthiness Criteria: Special Class Airworthiness Criteria for the Joby Aero, Inc. Model JAS4–1 Powered-Lift**AGENCY:** Federal Aviation Administration (FAA), DOT**ACTION:** Issuance of final airworthiness criteria.

SUMMARY: The FAA announces the special class airworthiness criteria for the Joby Aero, Inc. (Joby) Model JAS4–1 powered-lift. This document sets forth the airworthiness criteria the FAA finds to be appropriate and applicable for the powered-lift design.

DATES: These airworthiness criteria are effective April 8, 2024.

FOR FURTHER INFORMATION CONTACT: James Clary, Emerging Technology Coordination Section, AIR–611, Policy and Standards Division, Aircraft Certification Service, Federal Aviation Administration, 10101 Hillwood Parkway, Fort Worth, TX 76177; telephone 817–222–5138; email james.clary@faa.gov.

SUPPLEMENTARY INFORMATION:**Background**

The Joby Model JAS4–1 (Model JAS4–1) powered-lift has a maximum gross takeoff weight of 4,800 lbs. and is capable of carrying a pilot and four passengers. The aircraft uses six tilting electric engines with 5-blade propellers attached to a conventional wing and V-tail.¹ The aircraft structure and propellers are constructed of composite materials. As a powered-lift, the Model JAS4–1 has characteristics of both a rotorcraft and an airplane. The Model JAS4–1 is intended to be used for Title 14, Code of Federal Regulations (14 CFR) parts 91 and 135 operations, with a single pilot onboard, under visual flight rules (VFR).

On November 2, 2018, Joby applied for a type certificate for the Model JAS4–1 powered-lift. Under 14 CFR 21.17(c), Joby’s application for type certification is effective for three years. Section 21.17(d) provides that, where a type certificate has not been issued within that three-year time limit, the

applicant may file for an extension and update the designated applicable regulations in the type certification basis. Because the project was not certificated within three years after the application date above, the FAA approved the applicant’s request to extend the application for type certification. As a result, the date of the updated type certification basis is June 14, 2022.

The FAA issued a notice of proposed airworthiness criteria for the Model JAS4–1 powered-lift, which published in the **Federal Register** on November 8, 2022 (87 FR 67399). The FAA issued a notice extending the comment period to December 22, 2022, which published in the **Federal Register** on December 7, 2022 (87 FR 74994).

Discussion

Because the FAA has not yet established powered-lift airworthiness standards in 14 CFR, the FAA type certifies powered-lift as special class aircraft. Under the procedures in § 21.17(b), the airworthiness requirements for special class aircraft, including the engines and propellers installed thereon, are the portions of the requirements in 14 CFR parts 23, 25, 27, 29, 31, 33, and 35 found by the FAA to be appropriate and applicable to the specific type design and any other airworthiness criteria found by the FAA to provide an equivalent level of safety to the existing standards. These final airworthiness criteria announce the applicable regulations and other airworthiness criteria developed, under § 21.17(b), for type certification of the Model JAS4–1 powered-lift.

The Model JAS4–1 powered-lift has characteristics of both a rotorcraft and an airplane. It is designed to function as a rotorcraft for takeoff and landing, and as an airplane cruising at speeds higher than a rotorcraft during the enroute portion of flight operations. The electric engines on the Model JAS4–1 powered-lift will use electrical power instead of air and fuel combustion to propel the aircraft through six 5-bladed composite variable-pitch propellers. Accordingly, the Model JAS4–1 powered-lift proposed airworthiness criteria contained standards from parts 23, 33, and 35 as well as other proposed airworthiness criteria specific for a powered-lift and the engines and propellers installed thereon.

For the existing regulations that were included without modification, the proposed airworthiness criteria included all amendments to the existing parts 23, 33, and 35 airworthiness standards in effect as of the application date of June 14, 2022. These are part 23,

amendment 23–64, part 33, amendment 33–34, and part 35, amendment 35–10.

The Model JAS4–1 powered-lift proposed airworthiness criteria also included new performance-based airworthiness criteria. The FAA developed these criteria because no existing standard captured the powered-lift’s various flight modes and electric engines, and some unique characteristics of their propellers. The new requirements specific to the Model JAS4–1 in the proposed airworthiness criteria used a “JS4.xxxx” section-numbering scheme.

Because many of the proposed airworthiness criteria are performance-based, like the regulations found in part 23, the FAA has proposed to adopt § 23.2010 by reference, which would require that the means of compliance used to comply with the airworthiness criteria be accepted by the Administrator. Because no powered-lift consensus standards are currently accepted by the Administrator, the means of compliance will be accepted through the issue paper process.²

Summary of Changes From the Proposed Airworthiness Criteria

These final airworthiness criteria reflect the following changes, in addition to others as explained in more detail under Discussion of Comments: The FAA made changes to the aircraft performance section to incorporate an optional, “increased performance” approval, which requires greater aircraft performance capabilities beyond that of the baseline “essential performance” approval. The expectations for aircraft performance at both levels are clearly defined at the requirement level. Requirements to address various scenarios involving failures that can lead to loss of thrust were clarified and consolidated into a consistent terminology across all airworthiness criteria. Expectations were added for the aircraft to be capable of a controlled emergency landing following any condition where the aircraft can no longer provide the commanded power or thrust required for continued safe flight and landing (CSFL). The proposed requirement to incorporate a bird strike deterrent system was not adopted in these final airworthiness criteria, nor were other requirements not applicable to the Model JAS4–1, such as requirements for operations on water, approval for aerobatic flight, and others, as discussed in further detail under Discussion of Comments. The FAA

¹ A V-Tail aircraft design incorporates two slanted tail surfaces instead of the horizontal and vertical fins of a conventional aircraft empennage. The two fixed tail surfaces of a V-Tail act as both horizontal and vertical stabilizers and each has a moveable flight-control surface referred to as a ruddervator.

² See Order 8110.112A, *Standardized Procedures for Usage of Issue Papers and Development of Equivalent Levels of Safety Memorandums*.

modified and developed revised aeroelasticity criteria to more directly address concerns expressed by commenters related to “whirl flutter” and aeromechanical stability. The FAA revised requirements in response to numerous comments requesting clarification or recommending changes to address safety gaps in the proposed criteria, particularly in the areas of aircraft handling and control, structural airframe loads and durability, flight controls, protection of occupants, and protection of systems from high-intensity radiated fields (HIRF) and lightning. The FAA updated requirements for electric engines in response to requests for improved clarity on applicability and relationship to the airframe requirements. The FAA also updated definitions for “controlled emergency landing,” “CSFL,” and “sources of lift” and added a definition for “local events.”

Lastly, the FAA clarified that, should Joby apply to amend the type certificate to include another model powered-lift, these airworthiness criteria would apply to that model also, provided the criteria remain appropriate to the changed aircraft in accordance with part 21, subpart D. This change was necessary so that each future change to the aircraft will not necessarily require an application for a new type certificate.

Discussion of Comments

The FAA received responses from 46 commenters. The majority of commenters were government agencies, private companies, and organizations as follows: Alaka'i Technologies Corporation (Alaka'i); Aerospace Industries Association (AIA); AIBOT LLC (AIBOT); Airbus; Air Line Pilots Association (ALPA); Agência Nacional de Aviação Civil (ANAC); Archer Aviation Inc. (Archer); Ascot Aviation Associates (Ascot); Aerospace, Security and Defense Industries Association of Europe (ASD-Europe); Association for Uncrewed Vehicle Systems International (AUVSI); BETA Technologies, Inc. (Beta); United Kingdom Civil Aviation Authority (UKCAA); Civil Aviation Administration of China (CAAC); Diamond Aircraft; EASA; End State Solutions; General Aviation Manufacturers Association (GAMA); Hartzell Propeller (Hartzell); LDR; Japan Civil Aviation Bureau (JCAB); Lilium eAircraft GmbH (Lilium); Martin Aerotech; MTLs Aerostructure (MTLS); National Business Aviation Association (NBAA); Odys Aviation (Odys); Overair Inc. (Overair); Rolls-Royce Deutschland Ltd & Co KG (Rolls-Royce); Rotorcraft Drive Systems; Transport Canada Civil

Aviation (TCCA); Vertical Aerospace; and Volocopter GmbH (Volocopter). The FAA received comments from individual commenters as well.

Support

AIA, AUVSI, ASDIA, NBAA, and individual commenters expressed support for type certification of the Model JAS4-1 as a special class of aircraft and establishing airworthiness criteria under § 21.17(b). ALPA expressed support for the use of 14 CFR part 35 propeller airworthiness standards. An individual commenter expressed support for the CSFL and controlled emergency landing definitions.

Definitions

The FAA proposed criteria that created new or modified definitions for the Model JAS4-1 powered-lift. The FAA received and reviewed comments from AIBOT, Airbus, ASDIA, ALPA, Alaka'i, Beta, Diamond Aircraft, EASA, End State Solutions, GAMA, Hartzell, Lilium, MTLs, Odys, Overair, TCCA, UKCAA, Volocopter, and individual commenters that requested the FAA clarify, revise, or adopt as proposed certain definitions. Specifically, these comments were focused on the topic areas of “CSFL,” “controlled emergency landing (CEL),” and “loss of power/thrust,” along with requests for clarification on other uses of the term “thrust.” GAMA and Overair also proposed modifications to the “source of lift” definition. Additionally, comments from Airbus, ALPA, ASDIA, EASA, Odys, TCCA, UKCAA, and an individual commenter requested the establishment of a higher safety target for powered-lift like the Model JAS4-1. In response, the FAA created an “increased performance” approval that may be granted based on the aircraft's ability to meet higher performance standards for continued flight under certain failure conditions. The FAA modified JS4.2000(a) to provide for the higher safety target of “increased performance” as well as to establish the proposed minimum safety target for CSFL as “essential performance.” The Model JAS4-1 must meet either the essential or increased performance requirements in this certification basis. Additionally, the Model JAS4-1 may be approved for both essential and increased performance with appropriate and different operating limitations.

The FAA has modified the definition of “CSFL” to establish the different expected outcomes based on the performance approval sought. The definition of “CSFL” was modified slightly for the essential performance

approval to include pilot alertness; however the ability to continue to the planned destination or alternate is a requirement to meet the increased performance approval. Increased performance is a higher level of safety that guarantees fly-away capability after any failure not shown to be extremely improbable. Essential performance does not require the aircraft to have the capability to land at the planned or an alternate landing site as is required for increased performance.

Several commenters suggested the FAA adopt EASA's special condition for vertical take-off and landing aircraft (SC-VTOL) requirements for powered-lift. The FAA disagrees and has instead adopted “essential” and “increased” performance approvals. Although the FAA's “essential” and “increased” performance approvals are similar to EASA's “Category Basic” and “Category Enhanced” approvals, differences remain. The FAA is establishing these airworthiness criteria for the Model JAS4-1 to provide a certification basis for aircraft design approval, while the operational approval is accomplished outside of the aircraft certification process. Additionally, both the FAA's and EASA's performance levels include the aircraft's ability to conduct a controlled emergency landing after a condition when the aircraft can no longer provide the commanded power or thrust required for CSFL as specified in JS4.2105(g). To complete the integration of these defined levels of safety requirements, the FAA modified JS4.2115 “Takeoff performance,” JS4.2120 “Climb requirements,” and JS4.2130 “Landing” to incorporate the essential and increased performance requirements.

The FAA received several comments that the proposed definition of a “CEL” was not sufficient to ensure that the relevant instances that may be encountered in operation are addressed beyond a “critical loss of thrust” as required under the proposed JS4.2105(g). The FAA agrees with the concerns raised by these commenters. As such, the FAA revised the proposed CEL definition and the requirements in JS4.2105(g) to establish the minimum level of safety required when the aircraft can no longer provide the commanded power or thrust required for CSFL.

One commenter requested the FAA remove the part of the CEL definition that requires that the pilot be capable of choosing the direction and area of touchdown and instead require a controlled descent. As indicated by the term itself, “controlled emergency landing” is a defined airworthiness attribute in which the design maintains

sufficient control to change direction to an area of touchdown, while reasonably protecting occupants from serious injury. However, the FAA has updated the definition of CEL by relocating the pilot reference to focus the requirement on aircraft functionality. Overall pilot controllability requirements are addressed in JS4.2135, which requires that the aircraft be controllable and maneuverable without requiring exceptional piloting skill, alertness, or strength. The intent of the definition of CEL is to provide equivalency to the part 23 airplane gliding requirements and the part 27 rotorcraft autorotation requirements. Both minimize the aircraft's speed (forward and vertically) while still allowing directional control of the aircraft to an emergency landing.

One commenter requested the FAA clarify the statement "reasonably protecting occupants" in the definition of "CEL" and further commented that non-participants should also be protected since these aircraft plan to operate in highly-populated urban environments. The FAA agrees with the need to provide additional clarity and has modified the definition of CEL to clarify that the expected safety outcome is protection from serious injury, which inherently provides a level of protection for non-participants on the ground. This approach is similar to the level of safety in §§ 23.2270, 23.2320, and 23.2510 for normal category airplanes.

The FAA also received comments seeking clarification of the term "some damage" in the definition of CEL. The allowance for some damage to the aircraft exists in the 14 CFR 23.2000 definition of CSFL. For the Joby Model JAS4-1, this allowance was moved to the definition for CEL. The intent is that, although there may be aircraft damage, the occupants remain protected to the extent that egress may still be achieved following the landing.

The FAA received several comments requesting clarity on the meaning of "loss of thrust" and "critical loss of thrust" in JS4.2000 and throughout the airworthiness criteria. These terms were inherited from the existing airworthiness standards used to create the proposed airworthiness criteria. The FAA agrees that the "loss of thrust" term is inadequate for the Model JAS4-1, which incorporates distributed propulsion with an integrated flight and propulsion control system. Historically, this terminology was used to convey an assumed complete engine failure because of the critical nature that engines, propellers, and transmissions provided regarding continued flight or CSFL capability. With the advent of distributed propulsion, the underlying

assumptions of design features, mitigations, and substantiation of capability under endurance testing established within the legacy requirements are no longer valid, requiring revision.

Distributed propulsion with an integrated flight and propulsion control system adjusts the aircraft's flight path using aerodynamic and/or propulsive forces. In addition to addressing the complete loss of thrust at any individual location and its effects, the design must address additional failures from the flight and propulsion control system that may inadvertently generate more or less thrust than commanded by a pilot. For powered-lift with tilting nacelle designs like the Model JAS4-1, the design must also address the possibility of any given nacelle to fail in an orientation that does not match its commanded position, and account for the subsequent thrust vector that results. In part, some of these failures are identified through the system safety process. However, other considerations exist outside of that process that are necessary for identifying other critical failures. As such, the FAA has included a definition of "critical change of thrust" to address the thrust's magnitude and orientation. Critical change of thrust may consist of more than one condition depending on what flight conditions it adversely affects (performance, handling qualities, or both). A critical change of thrust will require a dedicated assessment encompassing all the above elements.

Further, the proposed definition for "loss of power/thrust" was not adopted in these final airworthiness criteria. Since this term was only used in the proposed JS4.2105(g), the final JS4.2105(g) requirement was rewritten to directly incorporate the previous "loss of power/thrust" definition language and clarify that the condition represents any scenario in which commanded thrust is insufficient to ensure CSFL, regardless of cause.

The FAA also received recommendations to modify the proposed "source of lift" definition to use terminology consistent with the powered-lift definition in 14 CFR part 1. The FAA agrees and has revised this definition to align with the powered-lift definition more closely.

One commenter requested the FAA clarify the meaning of "predominately" and what was meant by "combination" in the definition of "source of lift." The FAA has changed "predominantly" to "principally" in the JS4.2000(b)(3) of these final criteria, as the term "principally" is used in the part 1 definitions of powered-lift and

rotorcraft. The FAA intended for the definition of "source of lift" in JS4.2000(b)(3) to be aligned with the existing regulatory definitions of powered-lift and rotorcraft. The FAA intends the term "combination" to capture instances where the sources of lift involve both engine driven lift devices (e.g., rotors) and non-rotating airfoils (e.g., fixed wings), generally in a manner in which the balance between the two is varying during transition from wing-borne flight to thrust-borne flight and vice-versa.

The FAA received a comment seeking clarification on the use of the term's "transition" and "transitional" within the airworthiness criteria. The term "transition" is used within the airworthiness criteria to describe a change in configuration or mode of operation and is not an indication of a specific source of lift. Within the preamble of the notice of proposed airworthiness criteria, the term "transitional" is intended to mean the same as "semi-thrust borne." As the use of the term "transitional" to mean "semi-thrust borne" was limited to the preamble language, no modification to the airworthiness criteria is needed.

The FAA received a comment asking to replace the term "hover" with "taxi" in the listed phases of flight in JS4.2000(b)(2). The FAA disagrees, as the term "hover" refers to an airborne flight condition and "taxi" refers to movement while on the ground. Another commenter requested that the FAA add "taxi" to the criteria, since the terms is also used in JS4.2225. The FAA disagrees as the term "ground operations" in JS4.2000(b)(2) includes taxi operations. No changes were made as a result of this comment.

The FAA received comments asking that the terms "shutdown," "start," "restart," and "idle" be defined for electric engines. The FAA disagrees. The FAA intends that these terms have the same meaning as for existing engine technology, but recognizes that there may be some differences based on the specific design of the Model JAS4-1 and its engine operations.

The FAA received a comment questioning the applicability of part 33 requirements that used the term "rotorcraft." Upon further review, the FAA found similar issues with the references to "airplane" within part 33 and part 35. The FAA agrees with the concern and updated JS4.2000(c) to clarify that part 33 and part 35 requirements that use the terms "airplane" and "rotorcraft" mean "aircraft." This also prompted the FAA to remove the inappropriate reference to typical airplane installations in

§ 35.37(c)(2). The FAA also received a comment questioning the use of the term “of this part” in part 33. The FAA agrees; the revision to JS4.2000(c) also clarifies that “this part” means “these airworthiness criteria” when used in part 33 and part 35 requirements.

Lastly, the FAA added a definition for the term “local events” in response to comments requesting clarification of this term as used in requirements in subparts H and I.

Applicable Criteria

The FAA proposed applicable criteria by determining the appropriate airworthiness requirements that apply to the Model JAS4–1 powered-lift. These criteria are tailored to the powered-lift’s design, including its engines and propellers, as well as its construction, intended use, and suitability for compliance with operational requirements.

CAAC, EASA, GAMA, Liliium, Martin Aerotech, Odys, Overair, TCCA, Vertical Aerospace, and Volocopter requested the FAA remove sections and terms from the proposed airworthiness criteria that do not specifically apply to the Model JAS4–1 design. The FAA agrees and did not adopt the following in these final airworthiness criteria as they were not specifically applicable to the Model JAS4–1:

- JS4.2225(c);
- JS4.2240(b) (a new JS4.2240(b) has been added);
- § 23.2310;
- JS4.2320(d), (e) (the remaining requirements of JS4.2320 have been transitioned to § 23.2320);
- JS4.2325(h);
- § 23.2420;
- § 23.2435;
- § 23.2530(e);
- JS4.2540; and
- § 35.43.

The following phrases were not adopted in these final airworthiness criteria as they are not specifically applicable to the Model JAS4–1 design:

- JS4.2400(a): “or provides auxiliary power to the aircraft;”
- JS4.2405(a), (b), (c): “reverser system;”
- JS4.2430(a)(3): “and auxiliary power unit;” and
- JS4.2430(c), (c)(1), (c)(3): “refilling or.”

The FAA received comments that questioned the inclusion of HIRF and lightning requirements for aircraft approved for Instrument Flight Rules (IFR) operations. The requirements are conditional for IFR approved designs. The FAA found it prudent to specify basic design requirements for HIRF and lightning based on the expectation that

future design modifications could include an IFR approval. However, additional design and installation requirements beyond those specified in these airworthiness criteria would be needed for the aircraft to be approved to operate under IFR.

Lastly, the FAA received numerous comments noting that the airplane levels prescribed by 23.2005 should no longer be referenced in these criteria, as they apply to conventional airplanes and not to a powered-lift. The FAA agrees and has revised the airworthiness criteria accordingly.

Technical Areas in General Order of the Airworthiness Criteria Sections

Aircraft Performance, Handling, and Control

The FAA received and reviewed comments from Alaka’i, AIBOT, Airbus, ALPA, ANAC, ASDIA, Beta, Diamond Aircraft, EASA, End State Solutions, GAMA, Liliium, MTLs, Odys, Overair, Rolls-Royce, Rotorcraft Drive Systems, TCCA, Vertical Aerospace, Volocopter, and individual commenters requesting the FAA revise, remove, or clarify proposed airworthiness criteria related to aircraft performance, handling, and control for the Model JAS4–1.

The FAA received a comment noting the inconsistent use of terms when referring to the applicable atmospheric references in proposed JS4.2105, JS4.2115, and JS4.2130. Under JS4.2105(a), performance requirements at atmospheric conditions must be applied to all requirements in Subpart B unless otherwise prescribed, including JS4.2115 and JS4.2130. The FAA modified JS4.2115 and JS4.2130 to include fixed performance parameters for takeoff and landing, respectively; however, this does not negate the requirement to account for atmospheric conditions as denoted in JS4.2105(a).

One commenter suggested adding “at sea level” to JS4.2105(a), consistent with the language for levels 1 and 2 low-speed airplanes in part 23. The FAA disagrees. JS4.2105(a) as proposed achieves the intended safety objectives and aligns the airworthiness criteria with the appropriate level of safety intended by utilizing appropriate standards from both parts 23 and part 27, with revisions specific to the Model JAS4–1. The FAA did not modify JS4.2105(a) as a result of this comment.

The FAA received comments that stated a concern that proposed JS4.2105(b)(1) inadvertently limits airport altitudes to 10,000 ft. The FAA agrees and has changed the airworthiness requirement to develop performance data to the maximum

altitude for which certification is being sought.

The FAA also received a comment requesting clarification whether the 10,000 feet specified in JS4.2105(b)(1) should be expressed in either mean sea level or above ground level. The language in JS4.2105 is consistent with the existing airworthiness standard § 23.2105 and is referenced to the altitude above sea level. No change was made as a result of this comment.

One commenter requested revision of JS4.2105(c), stating the rule is too vague and recommending that a minimum crosswind limit be established similar to parts 27 and 29. The FAA received another comment requesting clarification on dealing with wind gusts arising in urban environments. The FAA agrees with the need for a minimum crosswind limit but does not agree that details addressing urban environments belongs in JS4.2105(c). The FAA revised JS4.2135(a)(6) in response to similar comments to specify a minimum of 17 knots all azimuth capability. The FAA did not change JS4.2105(c) as a result of these comments.

The FAA received comments about JS4.2105(f) expressing confusion about what the phrase “critical loss of thrust” means relative to a powered-lift design of the Joby JAS–4 type. As mentioned previously, the FAA replaced the phrase “critical loss of thrust” with a new term, “critical change of thrust,” which is defined in JS4.2000.

Several commenters noted inconsistent utilization of the term “flight envelope” and requested clarification. One such instance was identified in JS4.2135(a), where the criteria referenced an “operating envelope.” The FAA’s intent was not to imply this flight envelope was different from others referenced in these airworthiness criteria. To be consistent, the FAA has generally replaced “operating envelope” with “approved flight envelope” where applicable, such as in JS4.2105(f) and JS4.2135(a), except for JS.2425(b) and JS4.2710(d), where the proposed requirements define operating envelopes specific to the engine.

The FAA received several comments requesting clarification of the new term “loss of power or thrust” defined in proposed JS4.2000(b)(4) and used in proposed JS4.2105(g) to specify the required level of safety after a condition when the aircraft can no longer provide commanded power or thrust required for CSFL. This proposed term generated confusion with similar terminology referring to “loss of thrust” in other sections of the criteria. The FAA agrees that clarification is necessary and

therefore has not adopted the “loss of power/thrust” definition in final JS4.2000. The FAA has also revised JS4.2105(g) by replacing the term “loss of power or thrust” with the definitional language from proposed JS4.2000(b)(4).

Several commenters asked for clarification on JS4.2105(g) and the use of system safety or operational mitigations as the compliance showing. The FAA modified JS4.2105(g) to provide additional clarity. Revised JS4.2105(g) is intended to assure that in the event of cockpit mismanagement, energy exhaustion, improper maintenance, or other failures, a controlled emergency landing can be achieved. JS4.2105(g) establishes safety objectives and the FAA’s acceptance of a specific means of compliance is beyond the scope of these airworthiness criteria.

A commenter asked for clarification on JS4.2105(g) as to whether a conventional forward landing would be an acceptable mitigation for loss of power or thrust. A conventional forward landing may be acceptable if the aircraft is capable of a controlled emergency landing in that configuration. No changes were made as a result of this comment.

The FAA received comments requesting that the FAA more explicitly state that the speed for thrust-borne flight in JS4.2110 and JS4.2150 may include hover. The minimum safe speed determined in JS4.2110 must cover all phases of flight (including hover) and all sources of lift, and JS4.2150 uses that minimum safe speed. As such, no change to the criteria is necessary.

The FAA also received a request to revise JS4.2110 to require minimum safe speed for “each flight condition and configuration” instead of only for each flight condition. The FAA disagrees. The phrase “flight condition” includes the aircraft configuration, phases of flight, and the sources of lift. No change to the criteria is necessary.

Several commenters stated that the proposed airworthiness criteria for takeoff performance in JS4.2115, climb performance in JS4.2120, and landing performance in JS4.2130 do not establish sufficient minimum performance requirements to meet the public’s expectations and levels of safety. One commenter recommended rewording paragraph (b) of JS4.2115, JS4.2120, and JS4.2130 to require the applicant to account for a range of engine or distributed propulsion system failures instead of accounting for loss of thrust.

As explained previously, the FAA recognizes the need to clarify the difference in requirements for

“essential” and “increased” performance levels as defined in JS4.2000(b)(1) for the Model JAS4–1 with respect to the takeoff, climb, and landing performance criteria of JS4.2115, JS4.2120, and JS4.2130, respectively. The FAA has revised these performance requirements to include scenarios for all engines operating and for critical changes of thrust. As revised, JS4.2115, “Takeoff performance” addresses all engines operating, as well as critical change of thrust conditions, for both essential and increased performance levels. Essential performance level requirements ensure all engines operating takeoff capability and the capability to perform either a safe stop or safe landing following a critical change of thrust. Increased performance, while similar for safe stops, defines the requirements for continued takeoff following a critical change of thrust, including the capability to continue the climb and then subsequently achieve the configuration and airspeed specified for increased performance in JS4.2120, “Climb Performance.”

The FAA revised JS4.2120 to establish targets for both essential and increased climb performance for all engines operating, as well as after a critical change of thrust, as defined in JS4.2000. The FAA developed essential and increased climb performance requirements with all engines operating using part 23 requirements. Essential performance also requires that the applicant assess critical change of thrust impacts on takeoff and climb performance capabilities. Increased performance after a critical change of thrust defines minimum criteria utilizing part 23 and part 27 Category A climb requirements, dependent on the takeoff flight path and sources of lift defined in JS4.2000 along that path.

Multiple commenters requested clarity on where glide and autorotation performance are captured. The FAA added JS4.2120(e), which requires the applicant determine the performance for gliding or autorotation.

The FAA received a number of comments noting the lack of specificity in proposed JS4.2130. The comments noted that JS4.2130 was overly vague and did not provide enough substantive detail to support the intent of the criteria. The FAA agrees and has revised JS4.2130 to ensure the level of safety and capability for essential and increased performance for takeoff in JS4.2115 is consistent with the level of safety and capability for essential and increased performance for landing in JS4.2130. Landing under JS4.2130 now contains requirements for both essential

and increased performance levels, such that the aircraft must be able to make a landing upon a critical change of thrust. For increased performance, the FAA has also included a minimum criterion to safely transition to a balked landing condition following a critical change of thrust.

The FAA received a comment that determining the performance for all potential partial loss of power conditions in proposed subpart B may be impractical. The FAA agrees. As mentioned previously, a new term, “critical change of thrust” has been defined in JS4.2000 to identify the most critical thrust-related failure condition(s) for the Model JAS4–1 powered-lift. This term requires consideration of the most adverse effect on performance or handling qualities. The FAA modified JS4.2115, JS4.2120, JS4.2125, and JS4.2130 to use this new definition of critical loss of thrust.

A commenter requested clarification on the phrase “applicable sources of lift” in JS4.2135(a)(2). During a specific phase of flight, an aircraft design may only allow for a singular source of lift during that phase of flight. In other phases of flight, one or more sources of lift may be possible. Therefore, “applicable sources of lift” refers to only those allowable by the aircraft design. No changes were made as a result of the comment.

Multiple commenters requested the FAA establish an additional limit flight envelope which would establish the controllability limits of the aircraft. The FAA does not agree with this request. The FAA intended proposed JS4.2135 to establish the regulatory requirement for controllability that is used to define the approved flight envelope. The FAA recognizes that excursions outside of the aircraft’s approved flight envelope can occur and must be considered from a safety perspective. The FAA has replaced the proposed requirement of § 23.2160(a) with new JS4.2160 to address speed excursions beyond the approved flight envelope.

The FAA received multiple comments requesting the FAA utilize the multiple flight envelope concept in EASA’s SC–VTOL, in lieu of the proposed minimum safe speed requirement in JS4.2110. The commenters stated that the FAA’s proposed requirement may be appropriate for wing-borne flight, but it is not appropriate for other aircraft configurations. The FAA determined that the establishment of a minimum safe speed and an approved flight envelope establishes a level of safety for the Model JAS4–1 that is consistent with the safety levels established in parts 23 and 27.

The FAA also received comments seeking clarification on atmospheric effects, scoping, and sources of lift in regard to JS4.2110. The intent of that requirement is to address flight conditions in normal operation considering the most adverse conditions, which includes adverse atmospheric effects. Accordingly, no change to this requirement is necessary. Establishment of minimum safe speeds in regard to specific sources of lift will be established in the means of compliance.

Regarding controllability, the FAA received comments asking the FAA to adopt the requirement in § 23.2135(a)(3), to address “likely reversible flight control or propulsion system failure” instead of proposed JS4.2135(a)(3), which requires addressing “likely flight-control or propulsion-system failure.” Commenters further clarified that they believed flight controls are fully addressed by the proposed requirement that the Model JAS4–1 comply with § 23.2510. The FAA disagrees and determined that specific airworthiness criteria for controllability are needed to address the integration of the advanced flight-control system and the propulsion-system. In addition, JS4.2135(a)(3) is to ensure that likely failures not included in the system safety process of § 23.2510 are addressed and that failures that are included have an adequate handling quality assessment, which is outside the scope of § 23.2510. No changes were made as a result of these comments.

The FAA received a comment seeking clarity on the difference between JS4.2135(a)(3) and JS4.2135(a)(5), which requires addressing degraded flight control system operating modes not shown to be extremely improbable. The intent of JS4.2135(a)(3) is for the applicant to identify likely failures that can be seen in service that are not addressed by a system safety analysis. These may include mechanical or other single point failures. JS4.2135(a)(5) includes failures that are identified during the formal system safety process. The intent of JS4.2135(a)(5) is to ensure that those failures that result in degraded handling qualities are assessed. No changes were made as a result of the comment.

One commenter asked the FAA to remove JS4.2135(a)(5) because the requirements of proposed Subpart F would sufficiently mitigate this hazard. The FAA disagrees. JS4.2135(a)(5) requires controllability evaluation using approved flight test methods of compliance. The requirements in Subpart F, which apply to equipment,

do not adequately address this concern. No changes were made as a result of this comment.

The FAA received a comment to modify JS4.2135(a)(5) to remove the phrase “not shown to be extremely improbable.” The FAA disagrees. Removing this phrase would require the applicant to address all failure conditions regardless of their probability. The FAA included this phrase to limit the cases where handling qualities are evaluated to those conditions not shown to be extremely improbable to limit the applicants burden. No changes were made as a result of this comment.

Several commenters requested that a minimum level of safety be established with respect to proposed JS4.2135(a)(6), which requires that the aircraft can land safely in wind conditions. Multiple commenters questioned whether JS4.2135(a)(6) was only applicable to thrust-borne flight. The FAA concurs that a minimum level of safety should be defined and has amended JS4.2135(a)(6) to contain a more prescriptive all-azimuth minimum wind speed requirement of 17 knots. This minimum wind limit is applicable to the thrust-borne operations and is consistent with requirements for parts 27 and 29 rotorcraft.

The FAA received a comment that the term “loading” in proposed JS4.2135(a)(1) needed to be revised to include energy level considerations (*i.e.*, degraded or low battery). Energy level considerations are covered under JS4.2135(a)(3), (a)(5), and (b), which address propulsion system failures, flight control system operating modes, and critical control parameters such as limited-control power margins, respectively. Propulsion system failures include the electrical distribution and batteries. The same commenter proposed adopting a new requirement to address a rolling takeoff in maximum crosswind. The situation noted by the commenter is already addressed by JS4.2135(a)(2), which covers all phases of flight (*e.g.*, takeoff for the approved flight envelope including crosswinds). No changes were made as a result of these comments.

Multiple commenters asked for clarity on the phrases “critical control parameters” and “limited control power margins” in JS4.2135(b). The phrase “critical control parameters, such as limited control power margins” is intended to capture parameters or limits in which the aircraft is control or performance limited. The applicant must define these parameters as they apply to their unique design. No

changes were made as a result of these comments.

The FAA received a comment recommending that “change from one flight condition to another” be replaced with “transition from one flight condition to another” in JS4.2135(c). The FAA agrees and has updated JS4.2135(c) accordingly.

Several commenters stated that the language utilized from part 23, pre-amendment 23–64, in the development of proposed JS4.2145 did not provide appropriate granularity between static and dynamic stability and sources of lift for a powered-lift. The FAA agrees and has revised the requirements in JS4.2145 to account for the difference in stability requirements that arise between wing-borne, semi-thrust-borne, and thrust-borne flight for the Model JAS4–1.

The FAA received comments asking the FAA to provide specific likely failure cases to be considered in addition to more detailed control feel requirements in proposed JS4.2145(a). The FAA partially concurs with these comments. The intent of JS4.2145(a) is for the applicant to identify likely failures that may be encountered in service that are not addressed by system safety analysis; those could include mechanical or other single point failures. The FAA has revised the language in JS4.2145(a) to improve clarity but did not concur with the commenters’ request to identify specific failure conditions, including detailed control feel requirements.

The FAA also received a comment seeking clarity on the term “unstable” in JS4.2145(b). The FAA revised proposed JS4.2145(b) (now JS4.2145(c), due to changes discussed previously) to clarify that the intent is to ensure dynamic stability characteristics. The FAA intends “unstable” to mean the same as is stated in the criteria: that the characteristics do not increase the pilot’s workload or otherwise endanger the aircraft and its occupants.

The FAA also received comments regarding aerobatics and whether such proposed criteria are applicable to this class of vehicle or if instead the criteria should be better tailored to Joby’s design. The FAA agreed and revised JS4.2145 and JS4.2150 accordingly with the recognition that Joby is not seeking approval for aerobatics for the Model JAS4–1.

The FAA received a comment that proposed JS4.2150 may be adequate for wing-borne operation but not thrust-borne operation. The FAA agrees and has revised JS4.2150 to address all sources of lift.

The FAA received a comment asking for removal of proposed JS4.2150(b) as it was redundant. The FAA disagrees and finds it necessary to have an airworthiness requirement that the aircraft not inadvertently depart controlled flight.

The FAA also received a comment questioning the terminology “critical loss of thrust” in proposed JS4.2150(b). The FAA agrees this term was inappropriate for an aircraft capable of vertical takeoff and landing operations because it requires a hazardous test condition that would result in an initial adverse environment, which was not the intent. The FAA has updated JS4.2150(c) (previously proposed JS4.2150(b)) to replace “critical loss of thrust” with “sudden change of thrust” to remove this hazardous condition and to distinguish it from the term “critical change of thrust” defined in JS4.2000. The FAA intends the term “sudden change of thrust” to refer to short-term commanded thrust changes, whether directly by the pilot or from the flight control system in normal operation.

The FAA received comments on proposed JS4.2150 that a maximum speed limitation may be necessary to prevent loss of control on a powered-lift. The FAA agrees with the commenters, but because JS4.2150 relates to minimum safe speed requirements, the FAA has revised JS4.2160 to include this safety requirement in JS4.21060(b).

The FAA received a comment requesting clarification on the applicability of § 23.2155. The commenter questioned the necessity for this requirement with the assumption that powered-lift do not taxi under their own power. The FAA disagrees that this requirement should not be adopted as proposed, as the Model JAS4-1 has the ability to taxi. No changes were made as a result of the comment.

The FAA received a comment on JS4.2140(c) requesting removal of the word “likely” from the term “likely abnormal or emergency operations.” The FAA does not agree as the term is needed to appropriately bound the requirement. This is in alignment with § 23.2140(c), the existing airworthiness standard used to develop JS4.2140(c). No changes were made as a result of the comment.

The FAA also received a comment on proposed JS4.2140(c) suggesting the removal of “multi-engine.” The commenter stated that because the Model JAS4-1 is a multi-engine aircraft, including this term adds no value and may create confusion. The FAA agrees and did not adopt the reference to “multi-engine aircraft.”

Finally, the FAA received several comments about JS4.2140(c)’s use of the language, “loss of thrust not shown to be extremely improbable” in the context of trim system requirements. As mentioned previously, a new term, “critical change of thrust” was defined in JS4.2000 to provide an equivalent term adapted to the model JS4 design. The FAA modified JS4.2140(c) to use “critical change of thrust” as a result.

One commenter noted that proposed JS4.2140(a) should not be limited to just cruise flight. The FAA agrees and has removed the reference limiting the requirement to cruise flight.

Additionally, commenters expressed a concern that normal phases of flight utilized in proposed JS4.2140(a) and the flight conditions identified in proposed JS4.2140(b) may create some confusion. The FAA agrees and has revised the language in JS4.2140(a) to specify “normal operations” instead of “normal phases of flight.”

One commenter requested the FAA change the phrase “level flight” to “cruise” in JS4.2140(b)(2). JS4.2140(b)(2) references flight conditions and not phases of flight, and therefore “level flight” is appropriate. The commenter also requested the FAA add “hover” to JS4.2140(b). Hover does not have a longitudinal component, and as such trim in that axis is not applicable. Adjustments of trim may not apply any discontinuities as identified in JS4.2140(c). No changes were made as a result of these comments.

The FAA received comments concerning the use of the term “trim” in proposed JS4.2140 and questioning its appropriateness with fly-by-wire control systems that do not use traditional trimming arrangements. The FAA finds the requirements in JS4.2140 applicable because the Model JAS4-1 fly-by-wire flight controls may implement a trimming function rather than conventional trim device tabs or bias springs. Such a function would be equivalent to a trim or auto-trim device. No changes were made as a result of these comments.

One commenter requested that the FAA replace the term “primary flight controls” in proposed JS4.2140(a) and (b) with the term “inceptor.” The FAA disagrees. Although inceptors and effectors may fall under the term “primary flight controls,” the FAA does not find this change necessary as it prescribes a specific implementation of technology. No changes were made as a result of this comment.

Icing

The FAA received and reviewed comments from ALPA, EASA, GAMA,

Overair, and TCCA requesting the FAA revise, remove, or clarify proposed airworthiness criteria related to flight into known icing (FIKI) conditions as well as inadvertent icing encounters. Specifically, commenters requested the FAA explain why references to icing conditions requirements were excluded, revise the level of prescriptiveness of the criteria, and remove FIKI requirements because the Model JAS4-1 is not seeking FIKI approval at this time. At the same time, the FAA received comments requesting the FAA include more specific requirements for FIKI conditions.

Based on numerous comments received noting that Joby does not seek approval for FIKI on the Model JAS4-1 at this time, the FAA did not adopt proposed JS4.2165(a). Proposed JS4.2165(b) and (c), which address inadvertent icing encounters, remain applicable to the Model JAS4-1, and have been renumbered to JS4.2165(a) and (b), accordingly. JS4.2415 is similarly intended to capture any aircraft icing during an inadvertent encounter that adversely affects powerplant operation.

The FAA received comments requesting the FAA include requirements for recirculating snow and accumulation of ice and snow, because smaller rotors and airfoils, such as those on the Model JAS4-1, are known to be susceptible to the effects of snow and icing. The FAA agrees with concerns regarding the effect of scale on ice accretion, but finds they are addressed by proposed JS4.2165(b) (JS4.2165 (a) in these final criteria) for an inadvertent icing encounter. Recirculating snow and accumulation of snow are foreseeable conditions addressed by § 23.2415(a) for engine operation and by JS4.2600(a) for flightcrew visibility considering accumulations on the windshield due to recirculating snow.

The FAA received requests to remove proposed JS4.2165(b) since the Model JAS4-1 powered-lift is not seeking FIKI approval. The FAA does not agree, as proposed JS4.2165(b) (JS4.2165(a) in these final criteria) addresses inadvertent icing encounters, not FIKI. The relatively low revolution speed and resulting low centrifugal acceleration effect on ice shedding capability, as well as the effect of increased torque on electric engines, need to be addressed in an inadvertent icing encounter.

Lastly, the FAA received several comments on proposed JS4.2165(a), which the FAA did not adopt in the final rule. The commenters requested that the FAA explain why the reference to the icing conditions defined in appendix C of part 25 were excluded

from these airworthiness criteria. The icing conditions for which certification is sought will be defined in future amended airworthiness criteria should Joby seek icing certification after initial type certification. This will allow Joby to seek a standard that reflects their operating limitations.

Structural Design Loads

The FAA received comments from Airbus, ALPA, Diamond Aircraft, EASA, GAMA, Overair, Rolls-Royce, TCCA, Volocopter, and an individual requesting the FAA revise, remove, or clarify proposed airworthiness criteria related to structural design loads for the Model JAS4-1, including vibration and buffeting, flight modes, and wing borne vs. thrust-borne design loads.

The FAA received a comment to modify § 23.2215(a) to cover the whole operational envelope of the aircraft. The FAA does not agree. The objective of this criteria covers the structural design envelope, which may exceed the operational envelope requirement recommended by the commenter. The design envelope loads requirement will be further clarified in the means of compliance. No changes were made as a result of this comment.

A commenter recommended the FAA include the structural requirement for vibration and buffeting and harmonize with EASA's SC-VTOL.2215(b) for powered-lift, by adding "Vibration and buffeting must not result in structural damage up to dive speed, within the limit flight envelope" to § 23.2215.

The FAA agrees that vibration and buffeting must not result in structural damage, but the FAA does not agree to use the SC-VTOL.2215(b) language. The FAA finds that EASA's scope for vibration and buffeting in SC-VTOL is not sufficient for powered-lift. The FAA instead moved the proposed requirement to comply with § 23.2215 to JS4.2215(a) and added a new paragraph (b), which states, "There must be no vibration or buffeting severe enough to result in structural damage, at any speed up to dive speed, within the structural design envelope, in any configuration and power-setting."

Two commenters requested the FAA clarify the transitional flight mode for engine-driven lifting-device assembly provisions per JS4.2225(d). The commenters pointed out that the structural loads requirements for this special class of aircraft include loads resulting from the transitional flight phase that are not considered under loading conditions in parts 23 and 27. Specifically, the commenters were concerned that propellers, when repositioned in-flight relative to the

aircraft primary axis, may introduce unique load cases relative to conventional propeller loads that would impact the static strength evaluations. The commenters recommended the FAA capture requirements for loads in all phases of flight by revising JS4.2225(d). One commenter requested revising JS4.2225(d) to read "Engine-driven lifting-device assemblies, considering loads resulting from flight (including transitional flight mode) and ground conditions, as well limit input torque at any lifting-device rotational speed." Another commenter requested revising JS4.2225(d) to read "(d) Engine-driven lifting device assemblies, considering loads resulting from flight and ground conditions, limit input torque at any lifting-device rotational speed as well as propeller holding or clocking (locking) conditions if applicable."

The FAA agrees that all powered-lift flight configurations need clarification for the calculation of structural design loads for transitional flight phases. The FAA also recognizes that changes in propeller "disk" orientation during flight will affect aircraft loads resulting from the aerodynamic influence of the propellers on the aircraft. Similarly, the FAA considers it likely that aircraft aerodynamics loads will influence the propeller aerodynamic loads. Therefore, the FAA concluded that proposed JS4.2200 Structural Design Envelope should be revised instead of JS4.2225 (as suggested by the commenters) to include, "Thrust-borne, wing-borne, and semi-thrust-borne flight configurations, with associated flight load envelopes." The FAA added JS4.2200(g) accordingly.

Multiple commenters asked for clarity on the requirements in JS4.2225(d) and whether the intent of that criteria could be shown through means of compliance with JS4.2225(a). The FAA disagrees. JS4.2225(a) is specific to loads for the engine mount, whereas JS4.2225(d) is specific to lifting device assemblies.

Multiple commenters requested the FAA provide clarification in JS4.2200(b) with respect to appropriate design maneuvering load factors for powered-lift designs. The intent of JS4.2200 is to describe the various design envelopes that must be considered by the applicant in the loads analysis. No changes were made as a result of these comments.

One commenter requested that the FAA define the term "sufficiently" in JS4.2200(a)(1) and (2). As explained in the notice of proposed criteria, the FAA based proposed JS4.2200 on § 23.2200, with revisions to address the powered-lift structural design envelope. The terms "be sufficiently greater" in

JS4.2200(a)(1) and "provide sufficient margin" in JS4.2200(a)(2) have the same meaning, and will be applied to the Model JAS4-1 in the same manner, as in § 23.2200(a)(1) and (2). No changes were made as a result of the comment.

A commenter stated that JS4.2200(e), which proposed to require that the applicant account for each critical altitude up to the maximum altitude, does not consider redistribution of loads if deflections under load would significantly change the distribution of external or internal loads. EASA requested the FAA revise JS4.2200(e) similar to EASA SC-VTOL.2200(e). The FAA does not concur, as the critical altitude and redistribution of loads requirement in SC-VTOL.2200(e) is already captured by JS4.2200(e) and § 23.2210. No changes were made as a result of this comment.

The FAA received multiple comments questioning the requirement to use service history in the development of the design load maneuvering factors in JS4.2200(b), since the Model JAS4-1 has no service history. One commenter requested the FAA add specific language to the airworthiness criteria that points to using service history from existing normal category aircraft. The FAA agrees that the service history utilized in this showing should come from service experience from both rotorcraft and small airplane service history. However, the FAA disagrees that a change to the airworthiness criteria is necessary.

One commenter recommended the FAA revise proposed JS4.2225 to be more generic by specifying source of loads for any relevant structural components, and not only the components specific to the Model JAS4-1. The FAA disagrees, as these airworthiness criteria are specific to the applicant's design.

Structures

The FAA received and reviewed comments from ASDIA, Airbus, ANAC, EASA, GAMA, Liliium, Martin Aerotech, MTLs, Overair, Odys, TCCA, and Volocopter requesting the FAA revise, remove, or clarify proposed airworthiness criteria related to aircraft structure for the Model JAS4-1.

One commenter requested the FAA incorporate requirements equivalent to EASA SC-VTOL.2240(b) for structural durability. Several commenters suggested adding the level 4 airplane requirements for damage tolerance in § 23.2240(b) to JS4.2240 to incorporate damage tolerance principles. The FAA partially concurs with the recommendations of the commenters and has clarified to JS4.2240(b)

consistent with the FAA's long-standing policies regarding use of fail-safe methodology in conjunction with damage tolerance inspections. Fail-safe methodologies, also referred to as safety-by-design, incorporate multi-load-path structure (*i.e.*, redundant load paths) to act as back-up structure should any one of the original load paths (*i.e.*, fail-safe structure) fail. Damage tolerance (*i.e.*, safety-by-inspection) is a property of structure relating to its ability to sustain defects safely until those defects can be detected.

The FAA does not agree that adoption of § 23.2240(b) is necessary or appropriate, as this requirement is specific to airplanes that meet the definition in § 23.2005 for a Level 4 airplane that can carry 10–19 passengers. The § 23.2240(b) requirement for Level 4 airplanes was derived from § 23.574 at amendment 23–48 and excluded the option to use fail-safe methodologies for commuter category airplanes (Level 4). In addition, § 23.574(a) requires the use of damage tolerance and allows the use of safe-life in § 23.574(b) only when damage tolerance is found to be impractical.

Damage tolerance is one available option to use when complying with JS4.2240(a), along with the options to use safe-life and fail-safe methodologies, provided the fail-safe option relies on damage tolerance or safe life as stipulated in numerous FAA policies including AC 27–1B, “Certification of Normal Category Rotorcraft;” AC 23–13A, “Fatigue, Fail-Safe, and Damage Tolerance Evaluation of Metallic Structure for Normal, Utility, Acrobatic, and Commuter Category Airplanes;” and AC 91–82A, “Fatigue Management Programs for In-Service Issues.” The FAA notes further that the intent of adding JS4.2240(b) to these final criteria was to incorporate inspection when the fail-safe method is used. Incorporating inspections addresses long-standing and known deficiencies with fail-safe methodologies on all part 23 airplanes, as clarified in the preamble to the Notice of Proposed Rulemaking (NPRM) for amendment 23–64, in which the FAA identified potential shortcomings in the ability to detect all possible failure scenarios and ensure that all structural failures would be immediately obvious and corrected before further flight. The intent of structural durability requirements in both §§ 23.2240(a) and 27.571 is to use the appropriate application of safe-life or damage tolerance principles to ensure that fail-safe structure maintains the required safety margins without extended periods of operation with reduced safety margins.

The FAA agrees with the commenters that further clarification on the stipulations that govern use of fail-safe methodologies should be included in the Model JAS4–1 criteria to reiterate the FAA's requirements in this regard. Consequently, the FAA has added a new JS4.2240(b) that reflects the intent of § 27.571(d) together with amendment 23–64 and associated policies to incorporate damage tolerance principles into powered-lift aircraft. The requirements in JS4.2240(b) will mitigate deficiencies in the fail-safe option and will apply to the Model JAS4–1 structure beyond those elements specifically identified by § 27.571. This is consistent with § 21.17(b), which directs the FAA to use the requirements from existing airworthiness standards, as appropriate, to determine the level of safety for the aircraft.

Multiple commenters requested that the FAA align JS4.2240(c) with EASA SC–VTOL.2240(d). The FAA notes that JS4.2240(c) is similar to SC–VTOL.2240(d), although SC–VTOL.2240(d) refers to “lift/thrust unit” instead of “engine.” The EASA term “lift/thrust unit” includes the engine and propeller or rotor assembly. This topic is an ongoing discussion with foreign certification authorities. For the Model JAS4–1, other rotating parts within the system, except for propeller blades or rotors, should be evaluated using typical rotor burst methods, including shielding where practical.

The FAA received a comment to move JS4.2240(c) to outside of Subpart C Structures. The FAA disagrees as JS4.2240(c) is a requirement specific to structural durability and is appropriately included in JS4.2240, which is consistent with § 23.2240. No changes were made as a result of this comment.

Several commenters requested the FAA align § 23.2250(c) with the failure criteria in EASA SC–VTOL.2250(c). SC–VTOL.2250(c) contains a requirement for Category Enhanced that a single failure must not have a catastrophic effect upon the aircraft. The FAA's airworthiness criteria do not contain requirements equivalent to EASA's “Category Enhanced” requirements. However, the changes to JS4.2240(b) in these final criteria require inspections to reliably detect damage before it could result in a structural failure, therefore mitigating that structural failures do not result in a catastrophic failure. The FAA also changed the proposed requirement to comply with § 23.2250(c) to new JS4.2250(c) to require the applicant to prevent single failures from resulting in a catastrophic effect upon the aircraft.

The FAA received a comment requesting the airworthiness criteria include a requirement to address corrosion on metallic or semi-metallic structure components resulting from high voltage difference of electric potential. The FAA does not concur. JS4.2240(a) provides an appropriate regulatory framework for addressing corrosion, as it embodies the safety intent of the prescriptive requirements in pre-amendment 64 regulations § 23.573 and § 23.574, which directly address corrosion, among other factors, in both composite and metallic structure. This framework will be applied to the Model JAS4–1 in the same manner as § 23.2240 for normal category airplanes to address corrosion resulting from any source, including high voltage difference of electric potential. No changes were made as a result of this comment.

Multiple commenters requested clarification on the lack of environmental requirements in § 23.2260(e), which applies to only thermal effects. Environmental effects are addressed in § 23.2260(a), and as such the FAA made no change as a result of these comments.

Aeroelasticity & Aeromechanical Stability

The FAA received and reviewed comments requesting the FAA revise the proposed requirement to comply with § 23.2245 to address whirl flutter. The FAA agrees that whirl flutter and all similar dynamic instabilities related to rotating surfaces, non-aeroelastic aeromechanical stability, and power generating components should be addressed for the Model JAS4–1. However, the FAA disagrees with using the specific term “whirl flutter,” as doing so may incorrectly limit the scope to classical airplane whirl flutter only, and not address all possible instabilities for the Model JAS4–1 configuration.

Based on the commenter's recommendation, the FAA has replaced the proposed requirement to comply with § 23.2245 with new JS4.2245 to require that component and rotating surfaces must be free of any aeroelastic instability under each appropriate speed and power condition. Additionally, the FAA determined that the related issue of aeromechanical stability should similarly be addressed but does not consider it to be covered under the subject of aeroelasticity. Therefore, the FAA created a new section JS4.2241, “Aeromechanical stability,” incorporating requirements from rotorcraft airworthiness standards, similar to ground resonance requirements in § 27.241, to address

aeromechanical instabilities considered possible for the Model JAS4–1 when operating in thrust-borne and semi-thrust-borne flight.

Flight Controls

The FAA received and reviewed comments from Airbus, ASDIA, EASA, GAMA, Lilium, MTLs, Overair, TCCA, and an individual commenter requesting the FAA revise, remove, or clarify, proposed airworthiness criteria related to flight controls for the Model JAS4–1.

The FAA received a comment stating that 14 CFR part 23 amendment 23–64's requirements for flight controls should be sufficient for the Model JAS4–1 and the FAA should use those requirements. The FAA disagrees. Part 23 at amendment 23–64 did not envision the type or complexity of the design of powered-lift flight controls, such as those on the Model JAS4–1. No changes were made as a result of this comment.

The FAA received several comments that raised concerns with the suitability of proposed JS4.2300(b), which was developed from part 23 requirements for trim systems on normal category airplanes, for fly-by-wire powered-lift with distributed propulsion. The FAA concurs with the comments and modifies proposed JS4.2300(b)(2) by replacing the specific trim indications with a requirement that the trim systems and functions provide information necessary for safe operation. The specific indications listed in proposed JS4.2300(b)(2)(i)–(b)(2)(iv), which summarized the prescriptive indications from 23.677(a) and ASTM F3232 section 4.4, may be used as means of compliance with final JS4.2300(b)(2) if they are applicable, or they may be modified for the novel implementation of trim functions on the Joby Model JAS4–1.

Commenters raised concerns over the flightcrew control margin awareness for fly-by-wire flight control systems and recommended including a requirement addressing this issue. The FAA concurs with the comments and has added JS4.2300(a)(3) requiring the flightcrew to be made suitably aware whenever the means of primary flight control approaches the limits of control authority. For the context of this airworthiness criteria, “suitably aware” indicates an appropriate balance between nuisance alerting and necessary operation.

One commenter asked for clarification of the term “indirect flight-control systems” in JS4.2300(c). The FAA agrees that this term caused confusion. The FAA did not adopt this term and instead revised JS4.2300(c) for clarity.

Several commenters stated that proposed JS4.2300 was overly prescriptive because the requirements could be better addressed in means of compliance and could conflict with automation in fly-by-wire flight controls. In contrast, other commenters stated that proposed JS4.2300 was insufficiently prescriptive and noted that regulations need to explicitly guide applicants, especially for novel aircraft, and specific requirements for awareness of reduced flight envelopes should be provided.

The FAA considered these comments and revised proposed JS4.2300 to be less prescriptive in instances where other requirements adequately address the same safety objective. The FAA did not adopt the proposed requirements in JS4.2300(c)(1), (c)(2)(i), and (c)(2)(iii) because they were redundant with other requirements and were unnecessarily prescriptive. The FAA added a more prescriptive requirement specifically for control margin awareness in response to these recommendations.

One commenter suggested a revision to the phrase “the onset characteristics of each protection feature is appropriate for the phase of flight and type of maneuver” in proposed JS4.2300(c)(2)(i). The FAA notes there should be no discontinuous inputs into the flight control system from envelope protection systems, but agrees that abrupt inputs may be necessary in some situations (e.g., preventing stall in response to an atmospheric disturbance). The FAA determined that this requirement is adequately addressed by JS4.2300(a)(1) and therefore did not adopt proposed JS4.2300(c)(2)(i).

The FAA received a comment on § 23.2305 requesting that the FAA add a requirement for parking brakes. The FAA disagrees. Section 23.2305(b) requires a reliable means of stopping the aircraft. One means to accomplish this may include a parking brake; however, the applicant may propose other means. No changes were made as a result of this comment.

Occupant System Design Protection

The FAA received comments from ALPA, ANAC, EASA, GAMA, Lilium, Overair, Rolls-Royce, and TCCA on occupant system design protection requirements.

The FAA received comments seeking clarification on the proposed inclusion of the ditching exclusion in § 23.2315(a)(1) and a comment that this contradicts the proposed requirement to comply with § 23.2310 for seaplanes and amphibians. The FAA concurs that the language proposed caused confusion

and has revised these proposed requirements. The FAA did not adopt the proposed requirement to comply with § 23.2310 as it is not applicable to the Model JAS4–1. The FAA maintained the scope of § 23.2315 (now JS4.2315) specific to the “cabin configured for takeoff or landing” but did not adopt the exclusion for ditching because the Model JAS4–1 is not seeking ditching approval.

One commenter requested that the FAA require shrouding on propellers. The FAA does not concur with the comment. JS4.2315(a)(1), originally proposed as § 23.2315, requires that passenger doors are not located where they would endanger persons using the door. Operational requirements are also used to ensure safety of passengers, ground crews, and property, as required for existing aircraft. No changes were made as a result of the comment.

The FAA received comments regarding aerobatics and whether such criteria are applicable to this class of vehicle or if the proposed criteria for aerobatics should be removed. The FAA agrees and has removed the proposed requirement to comply with § 23.2315(b) because the Model JAS4–1 does not seek approval for aerobatics.

The FAA received comments asking the FAA to include the protection of occupants in proposed JS4.2320(a)(2). Another commenter asked for clarification of proposed JS4.2320(a)(2). Another commenter asked the FAA to modify proposed JS4.2320(a)(2) to protect the pilot, flight controls, and propulsion electrical power and control from propellers. The intent of proposed JS4.2320(a)(2) (now § 23.2320(a)(2) in these final criteria) is to protect the pilot and systems so the pilot can land the aircraft in the event of a propeller failure. Protection of the occupants embarking and disembarking is required by JS4.2315. Propulsion control is required by § 23.2320(a)(2) as a part of the flight controls on the Model JAS4–1. No changes were made as a result of these comments.

Bird Strike

The FAA received and reviewed comments from AIBOT, Airbus, Alaka'i, ALPA, ANAC, ASDIA, Beta, EASA, End State Solutions, GAMA, JCAB, Lilium, MTLs, Odys, Overair, Rolls-Royce, TCCA, UKCAA, Vertical Aerospace, Volocopter, and individual commenters requesting the FAA revise, remove, or clarify proposed airworthiness criteria related to bird strike requirements for the Model JAS4–1.

Some commenters requested that the FAA increase the bird-impact size, while other commenters requested that

the bird mass should not be prescribed, or a lower bird mass should be used with considerations for multiple bird strikes. Some commenters requested complete removal of the requirement, while other commenters only requested removal of the requirement for bird deterrence devices. Several commenters questioned the bird mass differences between the aircraft level requirement in proposed JS4.2320, the propeller requirement in § 35.36, and the bird ingestion evaluation in JS4.2718.

The FAA maintains the rationale presented in the notice of proposed airworthiness criteria for the proposed level of bird strike protection for the Model JAS4-1. The proposed requirements were based on the increased exposure to birds in the environment in which the Model JAS4-1 is expected to operate, the expectation of public safety, and the recommendations presented in the Aviation Rulemaking Advisory Committee (ARAC) Rotorcraft Bird Strike Working Group (RBSWG) report.³

The safety level obtained with the 2.2-lb bird strike requirement for transport category rotorcraft (as established in § 29.631) has been demonstrated in service to be sufficient. Similarly, the existing bird strike requirement with a 4.0-lb bird for type certificated propellers (established in § 35.36) has also been demonstrated in service to be sufficient. The bird ingestion requirements in JS4.2718 are not driven by either of these bird sizes. Therefore, the proposed bird impact protection requirement remains unchanged and will retain the proposed 2.2-lbs at the aircraft level, while maintaining propeller requirements at 4.0-lbs in § 35.36.

The FAA also considered the comments received on the bird deterrent system requirement in proposed JS4.2320(b), and the FAA concurs with not adopting this proposal. Although the FAA is aware of some research supporting the use of such devices, the FAA agrees the data is insufficient to mandate such a system at this time. The FAA encourages applicants such as Joby to consider voluntary implementation of these systems or similar bird deterrence mitigations, as good design practice.

The FAA also received comments that questioned whether the bird strike requirement should be listed under proposed JS4.2320, "Occupant Physical Environment," since as written, it

applies to more than just the occupant physical environment. The FAA agrees with these comments. The bird strike requirement placed in proposed JS4.2320 was intended and described in the notice as an aircraft-level requirement. Therefore, the FAA did not adopt proposed JS4.2320(b) and instead placed some of the requirements from proposed JS4.2320(b) into a new JS4.2311, "Bird Strike" in Subpart D, "Design and Construction," to reinforce its intent as a general, aircraft-level requirement.

Lastly, several commenters expressed concern with flocking bird strikes that could affect multiple engines at the same time and recommended this be addressed by the ingestion requirements in JS4.2718(a). The FAA notes that the airworthiness criteria in Subpart H apply to each single engine used in the aircraft distributed propulsion system. The requirements in JS4.2718(a) address ingestion from likely sources such as foreign objects, birds, ice, and hail, and are intended to capture engine effects from any ingestion source determined to be applicable to the Joby electric engine design. Common cause effects across multiple engines will be addressed under the applicable aircraft-level requirements, including § 23.2510, so no change to the engine airworthiness criteria is necessary.

Fire and High Energy Protection

The FAA received and reviewed comments from Diamond Aircraft, EASA, GAMA, JCAB, Lilium, MTLs, Odys, Overair, TCCA, and Volocopter requesting that the FAA revise, remove, or clarify proposed airworthiness criteria related to fire and high energy protection on the Model JAS4-1.

Several commenters recommended the FAA revise §§ 23.2325 and 23.2270 to protect against fires in baggage and cargo compartments propagating and creating an unsafe condition. The commenters suggested incorporating requirements similar to those in EASA SC-VTOL.2270, and further recommended clarifying proposed § 23.2325 by removing the references to part 23 airplane certification levels.

The FAA agrees with the need to mitigate the risk of fires in baggage and cargo compartments, commensurate with the intended level of safety for the Model JAS4-1. The FAA reviewed the baggage and cargo compartment fire protection requirements in parts 23 and 27, the intended operational uses of the Model JAS4-1, and the EASA SC-VTOL requirements. The proposed airworthiness criteria did not require the design to alert the pilot of a fire in a baggage or cargo compartment, or

require these compartments be constructed of or lined with fire resistant materials to protect the aircraft and occupants if the pilot was unaware of a baggage or cargo compartment fire. However, part 27 contains requirements to protect rotorcraft occupants from the risk of fire in a baggage compartment through the use of flame and fire resistant materials in its construction. The FAA revised proposed § 23.2325 (now JS4.2325) by removing the part 23 airplane certification levels. The FAA also added JS4.2325(e) requiring that the Model JAS4-1 baggage and cargo compartments be constructed of or lined with fire resistant materials, similar to § 27.855(a)(2), or be equipped with a fire or smoke detection system to allow the pilot to take immediate action to land, or be located where a fire would be visible to the pilots and accessible for the manual extinguishing of a fire, which adopts some elements of SC-VTOL.2270.

A commenter recommended the FAA revise proposed § 23.2325 to be more generic by specifying performance-based safety objectives. The FAA does not agree, as the revisions to proposed § 23.2325 (now JS4.2325) discussed previously are specific to the Model JAS4-1.

The FAA received comments recommending retaining the language in § 23.2330 of "designated fire zone" in lieu of the proposed JS4.2330 "fire zone." The term "fire zone" includes designated fire zones and new fire zones developed to address fire threats from new technologies. Much of existing guidance is defined for designated fire zones, which assume a fire involving kerosene or aviation gasoline. Other terms will be determined by the applicant, including designated fire zones, to distinguish between different types of fire zones and the fire threat that exists in those zones. The difference in language does not impose requirements beyond the intent of part 23, and also allows new fire zones to be established for aircraft using non-conventional propulsion and energy supply. No changes were made as a result of these comments.

The FAA received a comment to align the language in JS4.2330(a) and JS4.2330(b) ("fire zone") with the language in SC-VTOL.2330 ("designated fire zone"). As discussed above, the FAA has moved away from using the term "designated fire zone." EASA SC-VTOL.2330(a) is broader than JS4.2330(a) and includes additional components by applying to "flight critical systems" instead of only "flight controls." Although JS4.2330 is not as broad as EASA SC-VTOL.2330(a) as far

³ ARAC RBSWG Report, Rev. B, May 8, 2019, page 15, Section "Bird Mass" (ARAC RBSWG Report), https://www.faa.gov/regulations_policies/rulemaking/committees/documents/media/ARAC%20RBSWG%20Final%20Report%20Rev.%20B.pdf.

as the scope of components, it is broader with respect to the types of fire zones that those components must address, by using the term “fire zone” instead of “designated fire zone.” Protection of flight critical systems other than flight controls and ensuring CSFL after a fire or release of stored energy are addressed in JS4.2440 and § 23.2510.

The FAA received multiple comments to add survivable emergency landing fire protection requirements to § 23.2325. The FAA disagrees as this is covered by JS4.2430(a)(6). No changes are necessary as a result of these comments.

The FAA received a comment to add a requirement to JS4.2335 to minimize the risk of electrical shock to the crew, passengers, service, and maintenance personnel similar to the requirement in § 27.610(d)(2). This concern is adequately addressed by proposed JS4.2335(b), which requires the appropriate protection against hazardous effects caused by accumulation of electrostatic charge. No changes were made as a result of this comment.

The FAA also received a comment to revise JS4.2335(b) to require protection against catastrophic and hazardous effects. The proposed airworthiness criteria state that the aircraft must be protected from hazardous effects, which represent the minimum hazard level that must be addressed; by definition, this requires that catastrophic effects must also be addressed. No changes are necessary as a result of this comment.

The FAA received comments questioning proposed JS4.2440 in lieu of requiring compliance with § 23.2440 for powerplant fire protection. JS4.2440 is more performance-based, allowing for all powerplant related fire protection concerns to be covered by a singular airworthiness criteria. No changes are necessary as a result of this comment.

The FAA received comments recommending replacing the term “powerplant system” in JS4.2440 with “powerplant” or “powerplant installation.” The FAA does not concur as the proposed terminology is consistent with § 23.2410. No changes were made as a result of these comments.

Propulsion Safety and Integration

The FAA received comments from Airbus, ASDIA, EASA, GAMA, Hartzell, JCAB, Lilium, Odys, Overair, TCCA, Rolls-Royce, Volocopter, and an individual commenter requesting that the FAA revise, remove, or clarify the proposed airworthiness criteria related to propulsion safety and integration on the Model JAS4–1.

Proposed JS4.2405(d) specifies “extremely remote” as an acceptable probability of failure for power or thrust control systems, assuming manual backup capability. Several commenters stated that reliance on manual backup control of power or thrust on distributed propulsion powered-lift aircraft is unlikely to be acceptably achievable to ensure CSFL, and that failure of the propulsion control system is potentially catastrophic. Commenters also stated that specifying the power or thrust control system failure probability as extremely remote may be inconsistent with the extremely improbable requirement in JS4.2135.

The FAA agrees the airworthiness criteria should not specify an acceptable failure probability for power or thrust control systems on a distributed propulsion powered-lift. Additionally, the FAA agrees that control of distributed propulsion powered-lift, using manual control of individual engines and propellers, should not be assumed. The FAA revised JS4.2405 by not adopting proposed paragraph (d). The appropriate hazard classification and failure probability for power or thrust control systems will be determined using the aircraft-level system safety process in § 23.2510, as well as JS4.2135, if controllability is affected.

The FAA received a comment that JS4.2405(b) and § 23.2410(a) contradict one another, with the suggestion to remove the phrase “if CSFL cannot be ensured, the hazard has been minimized” from § 23.2410(a). The FAA disagrees. JS4.2405 establishes the safety objective for power or thrust control systems, whereas § 23.2410 is applicable to all powerplant systems and permits minimization of the hazard in limited cases. No changes were made as a result of this comment.

Multiple commenters recommended the FAA replace proposed JS4.2405 (power or thrust control systems) and JS4.2425 (powerplant operational characteristics) with a requirement to comply with § 23.2405 (automatic power or thrust control systems) and 23.2420 (reversing systems), or otherwise address those systems under the safety analysis requirements of § 23.2510. Commenters also recommended the airworthiness criteria be revised to allow the propulsion-control system to be evaluated along with the flight control system within the aircraft-level safety analyses required by § 23.2510. The FAA does not agree with these recommendations and notes that § 23.2405 and 23.2420 are not limited to functions defined in former § 23.904 and 23.933, as discussed in the

preamble to part 23 amendment 23–64.⁴ As noted previously, the FAA agrees that for the Model JAS4–1, the engines and propellers should be considered part of the flight control system, to include at a minimum all equipment and systems used for control of pitch, roll, yaw, and vertical motion. Furthermore, the subsystem analysis required by JS4.2405 for the engine power or thrust control system does not relieve the applicant from aircraft-level requirements such as JS4.2300, § 23.2500, or 23.2510 when incorporated into a system such as the flight control system. Conversely, specific subsystem requirements, such as JS4.2405, are not imposed on other subsystems that make up a higher-level system simply because they become part of a higher-level system. The FAA did not change the proposed criteria as a result of these comments; however, as noted previously, references to the “reverser system” in proposed JS4.2405 have not been adopted because that system is not applicable to the Model JAS4–1.

One commenter requested that the FAA include tilting systems in proposed JS4.2405(a). As stated in the preamble of the notice of proposed airworthiness criteria, JS4.2405 addresses nacelle rotation, which encompasses tilting systems as well as systems in which the nacelle is attached to a movable lifting surface. No changes were made to the criteria.

Multiple commenters requested the FAA consider modifying JS4.2425(b), “Powerplant Operational Characteristics,” to include wording from SC-VTOL.2425(b) that would only require inflight engine shutdown and restart capability if the safety benefits outweigh the hazards. Another commenter requested clarity on JS4.2425, which requires a means for shutdown and restart of the powerplant within an established operational envelope. It does not prohibit procedures or control logic that would restrict engine restart under certain conditions. The FAA disagrees with modifying the criteria. The FAA will address the requirements of appropriate shutdown and restart procedures through the aircraft flight manual limitations and operating procedures. No changes were made as a result of these comments.

One commenter suggested the FAA change JS4.2430(a)(1) to include “control and management systems” along with energy storage and supply systems. The FAA agrees that battery control and management systems are

⁴ 81 FR 96639 (Dec. 30, 2016).

covered by JS4.2430(a)(1) in addition to § 23.2525, but do not consider a change necessary as the FAA considers the term “energy storage and supply systems” to include battery control and management systems. The FAA received another comment requesting to remove § 23.2525(b) as it was duplicative to JS4.2340(a)(1). The FAA does not agree with this proposal and made no changes from the comment as § 23.2525 addresses required power for intended operations for all aircraft systems that use the electrical storage system, whereas JS4.2430(a)(1) contains propulsion criteria that ensures the independence between multiple electrical storage systems providing electrical power to the propulsion system.

Commenters requested the FAA clarify “where the exposure to lightning is likely” in JS4.2430(a)(2), which they believe could be interpreted in different ways. One interpretation suggested by commenters is to consider “likely” as it applies to areas of the aircraft where lightning may strike, while another interpretation is in reference to operating environments where lightning is likely. The FAA agrees with this concern and has revised the airworthiness criteria by removing the phrase “where the exposure to lightning is likely.” The FAA notes that JS4.2430(a)(2) and § 35.38 assume the aircraft will be exposed to lightning regardless of any environmental operating limitations and require protection of the energy system from catastrophic events. The applicant will show compliance with JS4.2430(a)(2) for the Model JAS4–1 consistent with other type certificated products by identifying areas of the powered-lift where direct attachment of lightning is “likely,” along with evaluating the resulting effects.

The FAA received a comment asking the FAA to consider the failure due to overload of the landing system in JS4.2430(a)(6). The Model JAS4–1 is not required to address specific failures due to overload of the landing system since its landing system is not located near its energy storage systems. No changes were made as a result of the comment.

The FAA received a comment requesting that airworthiness criteria be added to protect occupants from possible hazards from the energy systems. The FAA notes that proposed JS4.2430(a)(6), as written, covers this and therefore did not make changes as a result of this comment.

The FAA also received a comment recommending that JS4.2430(a)(6) be expanded to include minimizing hazards to emergency service

responders in addition to occupants. The FAA concurs with this suggestion and adds first responders to the airworthiness criteria.

Commenters requested the FAA explain the reservation of proposed JS4.2430(a)(7) and JS4.2430(c)(2). A commenter also recommended the FAA adopt EASA SC–VTOL.2430(a)(7) and add it as JS4.2430(a)(7) to ensure appropriate power quality within the energy system. The FAA did not incorporate the requirements from 23.2430(a)(7), which are similar to the requirements from EASA SC–VTOL.2430(a)(7), or (c)(2) into the Model JAS4–1 proposed criteria, and instead listed them as “Reserved,” because they cover physical contamination of stored energy. Stored electrical energy is not susceptible to physical contamination in the way that convention fuel is. Damaged or failed electrical storage and distribution systems may prevent delivery of stored electrical energy to an intended load, which is a different condition than contaminated energy. The FAA notes these concerns are covered by uninterrupted energy supply and fluctuation requirements under JS4.2430(a)(4). To avoid confusion, the FAA did not adopt the proposal to “reserve” paragraphs JS4.2430(a)(7) and (c)(2) and renumbered (c)(3) accordingly.

The FAA received a comment that likely hazards for energy systems are not limited to temperature influences as mentioned in JS4.2430(b)(2). The FAA agrees and did not adopt the qualifier “due to unintended temperature influences” in these final airworthiness criteria.

Several commenters suggested clarification on the application of system safety requirements, propulsion requirements, and flight control system requirements due to the integration of these functions on the aircraft. The commenters questioned whether power or thrust control system requirements need to be applied to flight control systems or if flight control system requirements need to be applied to power or thrust control systems. The FAA concurs with the commenters’ request to consider the engines and propellers part of the flight control system. The flight control system includes, at a minimum, all equipment and systems used for control of pitch, roll, yaw, and vertical motion. The FAA notes that the subsystem analysis required by JS4.2405 for the engine power or thrust control system does not relieve the applicant from higher-level requirements such as those in JS4.2300, § 23.2500, or § 23.2510, when engine or

thrust control systems are incorporated into a higher-level system such as the flight control system. Conversely, specific subsystem requirements such as JS4.2405 would not be imposed on other subsystems that make up a higher-level system simply because they become part of that higher-level system. The safety requirements in § 23.2510 apply at the aircraft level to the integrated functions of all systems on the aircraft, in addition to specific system requirements such as JS4.2300 and JS4.2405.

Several commenters expressed concern regarding the appropriateness of the system-level safety objectives in proposed JS4.2405 and § 23.2425 for such highly integrated systems. The commenters suggested JS4.2405 and JS4.2425 are not necessary, since compliance with § 23.2510 can require the applicant to define both system and aircraft level safety objectives.

The FAA recognizes there may be inconsistencies between safety objectives required at the powerplant installation level and those at the aircraft level, but notes this is the case for type certificated airplanes and rotorcraft. Existing powerplant rules define a minimum level of safety that permits certification of a broad range of products for single and multi-engine aircraft. One common requirement for powerplant installations has been the “no single failure” concept, which is practically applied given the number of engines installed. This concept remains critical even for highly integrated and distributed powerplant systems. Aircraft level safety objectives may not drive the level of safety typically provided in a powerplant installation, such as isolation between all engines on a multi-engine aircraft with more than two engines, so the powerplant requirements establish a minimum safety objective that may not always align with those at the aircraft level. As powered-lift and distributed propulsion systems evolve, there may be less need to capture powerplant installation unique safety requirements. Until then, the FAA will use JS4.2405 to capture those requirements for the Model JAS4–1 and ensure the powerplant installation level of safety is appropriate regardless of the aircraft level safety objectives.

Multiple commenters requested clarification regarding the definition of “energy” and the instances in the criteria where liquid fuel is still relevant, despite the consideration of electric propulsion systems. The term “fuel” is used in part 23 and includes any form of energy used by an engine or powerplant installation, such as provided by carbon-based fuels or

electrical potential.⁵ The FAA recognizes that using the term “fuel” instead of “energy” has implied the criteria are limited to non-fossil-fuel-based propulsion systems and is inconsistent with language used by other airworthiness authorities. As such, the FAA has replaced the term “fuel” with “energy” throughout these Model JAS4–1 airworthiness criteria. The FAA notes that “energy” includes any form of energy, including carbon-based fuels, electrical potential, and other means of energy storage or power generation for propulsion.

Several commenters requested that the FAA revise proposed JS4.2400(b) to clarify that the Model JAS4–1 engines and propellers will not be individually issued type certificates, but rather approved under the aircraft’s type certificate, and as such, any requirements mentioning the “type certificate” should be excluded. The FAA agrees and has revised JS4.2400(b) to remove the requirement that each engine and propeller installed on the Model JAS4–1 have a type certificate.

The FAA received comments to add “propeller” to JS4.2400(c) and specifically mention “propeller vibration” in JS4.2400(c)(4). The FAA does not agree. Powerplant installation as defined in JS4.2400(a) includes all components for propulsion, which includes propellers. Thus, propeller vibration and fatigue are covered by the requirement in JS4.2400(c)(4). No changes are necessary as a result of the comments.

The FAA received a comment to distinguish between airplane and engine hazards in JS4.2400(e). The requirement in JS4.2400(e) addresses powerplant components at the aircraft level. Engines are one of many powerplant components installed at the aircraft level, each of which must meet any limitations or installation instruction provided with that component or be shown to not to create a hazard. Engine specific hazards for the Model JS4–1 are found in subpart H of the airworthiness criteria. The FAA disagrees that the distinction requested by the commenter is necessary, and no changes were made as a result of this comment.

The FAA received comments requesting the FAA either remove § 23.2525(c) and modify JS4.2430(a)(3) to explicitly include energy storage systems, or revise § 23.2525(c) to remove the primary source failure consideration. The FAA disagrees. Section 23.2525 addresses required power considering the failures and malfunctions of the primary source at

the aircraft level, whereas the requirements in JS4.2430(a)(3) are specific to energy systems used for propulsion. No changes were made as a result of these comments.

System Safety

The FAA received and reviewed comments from ASDIA, AIBOT, Airbus, ALPA, EASA, End State Solutions, GAMA, Liliium, Odys, Vertical Aerospace, Rolls-Royce, TCCA, UKCAA, Volocopter, and individual commenters requesting the FAA revise, remove, or clarify proposed airworthiness criteria related to system safety and cybersecurity requirements for the Model JAS4–1.

Several commenters cited differences between EASA’s SC–VTOL and the proposed FAA airworthiness criteria for the Model JAS4–1 with regard to EASA’s creation of a “Category Enhanced” set of requirements. EASA included a structural requirement in SC–VTOL.2250, “Design and construction principles,” that for Category Enhanced a single failure must not have a catastrophic effect upon the aircraft. The FAA acknowledges that the airworthiness criteria for the Model JAS4–1 as a special class aircraft differ from the requirements in EASA’s SC–VTOL, which is a set of generalized requirements intended to cover a class of aircraft. The FAA’s long-standing technical practice manages risk due to structural failures through the use of critical or life-limited parts, which mitigates any need to address potential catastrophic structural failure modes under the system safety requirements of § 23.2510. While this practice differs from that of EASA’s approach, the FAA finds both approaches comparable and acceptable for risk mitigation. As discussed previously, the FAA revised proposed § 23.2250(c) (now JS4.2250(c)) to add a requirement that single failures must not result in a catastrophic effect upon the aircraft.

One commenter requested the FAA adopt language from § 29.953(a)(2) to require that the energy system allow power to be supplied to each powerplant through a system independent of those parts of each system supplying energy to other powerplants. The FAA does not concur that this addition is necessary or appropriate. Proposed JS4.2430(a)(1) and (a)(3) were derived from § 27.953 for multi-engine normal category rotorcraft and § 23.953(a) for multi-engine normal category airplanes and are appropriate to address the issue of energy loads required for propulsion for the Model JAS4–1. The FAA notes that these sections capture the intent of what

the commenter seeks to address by incorporating § 29.953, which is applicable to transport category rotorcraft. Section 23.2525(c) ensures power remains available for essential loads to supply other critical systems.

Several commenters identified that these criteria do not include specific failure condition probability targets or required development assurance level criteria and requested that they be included with appropriate rationale. The FAA does not agree, as existing aircraft airworthiness standards (parts 23, 25, 27, and 29) also do not prescribe specific failure condition probability targets or development assurance level criteria. This guidance may be found in advisory circulars or industry consensus standards, which provide one means, but not the only means, for showing compliance with the regulatory requirements. These means will likely need to be modified to consider powered-lift designs such as the Model JAS4–1.

One commenter recommended the FAA revise the proposed requirement to comply with § 23.2510 to include a clarification on the applicability of the standard, as it pertains to systems and equipment installed in the aircraft and how it relates to other requirements contained in other sections of the airworthiness standards. The FAA disagrees. The FAA proposed that the Model JAS4–1 comply with § 23.2510 without modification because the FAA intentionally developed that rule as a regulation of general requirements that do not supersede any requirements contained in other part 23 sections. The FAA intends the same application for the Model JAS4–1.

Several commenters expressed concern over the absence of a “no single failure” catastrophic failure condition criteria in these airworthiness criteria, citing its inclusion in EASA SC–VTOL.2510(a)(1). The FAA does not agree that a specific requirement prohibiting catastrophic single failures is necessary in the airworthiness criteria. Existing parts 23, 25, 26, and 29 airworthiness standards do not contain a “no single failure” requirement for catastrophic failure conditions, and the FAA consider these longstanding existing airworthiness standards acceptable. Although preventing “single failures” is addressed in FAA guidance material (e.g., Advisory Circulars 25.1309–1A and Advisory Circular 27–1B), it is one means, but not the only means, for showing compliance with the regulatory requirements. The FAA intends the same application for the Model JAS4–1.

⁵ 81 FR 96641 (Dec. 30, 2016).

Several commenters recommended the FAA clarify requirements for addressing cybersecurity. The FAA is addressing cybersecurity through JS4.1529 and § 23.2500, § 23.2505 and § 23.2510. The FAA concurs that these aircraft involve many new technologies which are highly integrated, and any cybersecurity vulnerabilities must be appropriately assessed and addressed through an accepted means of compliance. No changes were made as a result of these comments.

Lightning Protection

The FAA received and reviewed comments from EASA, GAMA, Lilium, Overair, and TCCA requesting the FAA revise, remove, or clarify proposed airworthiness criteria intended to address hazards that may result from a lightning attachment on the Model JAS4-1. These requirements include consideration for lightning common cause effects due to the potential for simultaneously affecting multiple systems. The proposed airworthiness criteria considered inadvertent exposure to lightning producing environments, including flight into clouds, as well as cold or icy weather conditions. The FAA determined that the highly integrated systems of the Model JAS4-1 aircraft require lightning protection.

One commenter requested the FAA clarify why the lightning indirect effects requirements are not applicable to systems with major failure conditions. The FAA notes that the lightning requirements are intended to be applicable to systems with major failure conditions for aircraft approved for IFR operations. For aircraft approved for IFR operations, proposed JS4.2515(b) is applicable to systems with hazardous or major failure conditions, similar to § 27.1316(b).

Multiple commenters recommended the FAA revert proposed JS4.2515 to § 23.2515 to limit the applicability of lightning requirements to aircraft approved for IFR operations that cannot show exposure to lightning is unlikely. The Model JAS4-1 incorporates systems that are critical in VFR and IFR operations that require protection against indirect effects of a lightning strike. A lightning attachment may occur during flight, when operating through or in the vicinity of lightning producing environments. Aircraft operating in instrument meteorological conditions (IMC) may encounter lightning, and aircraft operating in day or night visual meteorological conditions may inadvertently encounter lightning producing environments such as flight into clouds and freezing or icy weather conditions. Systems that

perform functions essential to CSFL must demonstrate immunity to lightning for all operations to achieve the intended safety objectives for catastrophic failure conditions. The FAA finds the requirements in JS4.2515 to be appropriate for the systems on the Model JAS4-1 and made no changes as a result of these comments.

The FAA received a comment asking for clarification of JS4.2515(a)(2), stating that it could be incorrectly interpreted as the system could be allowed to fail when exposed to lightning without recovery after exposure. The FAA does not agree that JS4.2515(a)(2) may be misinterpreted. Demonstration of lightning immunity is required for systems with catastrophic failure conditions. The exception for recovery conflicts in JS4.2515(a)(2) is based on aircraft operational or functional requirements independent of lightning exposure. The expectation is that a system recovers normal operation of a function without impact to safety of flight by design. No changes were made as a result of this comment.

Multiple commenters recommended the FAA consider whether systems with hazardous and major failure conditions must meet lightning requirements for aircraft not approved for IFR operations. The FAA notes that aircraft not approved for IFR operations are restricted from flight into IMC and must use outside visual references. An aircraft operating in IMC may encounter lightning producing environments, a hazard which requires more stringent requirements than for aircraft certified exclusively for VFR operations. Limiting JS4.2515(b) to IFR operations therefore maintains the level of safety intended for protection against lightning threats. Section JS4.2515(b) is applicable to IFR operations and systems with hazardous (level B) or major (level C) failure conditions. Section JS4.2515(a) is applicable to all operations and systems with catastrophic failure conditions. This approach achieves the intended safety objectives.

Commenters recommended deleting the word “significantly” from the text of JS4.2515(b) so that the requirement is clearly identified as applicable to electrical and electronic systems with hazardous and major failure conditions. The FAA concurs since JS4.2515(b) is applicable to IFR operations and systems with hazardous or major failure conditions. The FAA did not adopt the term “significantly” from proposed JS4.2515(b) to ensure both major and hazardous failure conditions are appropriately assessed.

HIRF

The FAA received and reviewed comments from EASA, Overair, and TCCA requesting the FAA revise, remove, and clarify proposed airworthiness criteria related to HIRF exposure.

Commenters requested consideration for HIRF common cause effects due to the potential of affecting multiple systems simultaneously, since radio frequency transmitters are continuously evolving, and future spectrum expansions are anticipated. The FAA agrees that the HIRF environment and sources are unpredictable and that the aircraft and highly integrated systems require robust HIRF protection, but considers the proposed requirements adequate to address this concern.

One commenter requested the FAA clarify why operation under IFR is considered to relax the HIRF requirements, but not the lightning criteria. Another commenter requested the FAA clarify why the HIRF requirements are not applicable to systems with major failure conditions. Several commenters also requested the FAA remove the limitation that § 23.2520(b) be only applicable for aircraft approved for IFR operations, similar to SC-VTOL.2520(b).

The FAA notes that proposed JS4.2515 and JS4.2420 provide consistent requirements for the protection of electrical and electronic systems from the effects of lightning and HIRF, respectively. The FAA does not concur that the HIRF requirements are relaxed for IFR. JS4.2520(a) is applicable for all operations and systems with catastrophic failure conditions, aligned with JS4.2515(a). Limiting JS4.2520(b) to IFR operations maintains an acceptable level of safety, as JS4.2520(b) is intended to be applicable to systems with hazardous or major failure conditions. This also aligns with similar requirements in JS4.2515(b) for lightning. The FAA did not adopt the term “significantly” from proposed JS4.2420(b), similar to JS4.2515(b), to ensure that major and hazardous failure conditions are appropriately assessed for HIRF as well as for lightning. This approach achieves the intended safety objectives and aligns the airworthiness criteria with the appropriate level of safety intended by utilizing appropriate standards from both parts 23 and part 27, revised to be appropriate for the Model JAS4-1.

Equipment

AIBOT provided a comment that requirements demarcate lighting patterns subject to flight modes such as

vertical takeoff and landing or fixed-wing operation. The FAA disagrees. FAA lighting requirements for the Model JAS4-1 are defined in § 23.2530, consistent with requirements for normal category airplanes.

Flightcrew Interface

The FAA received and reviewed comments from ALPA, EASA, GAMA, Lilium, Odys, Overair, and TCCA requesting the FAA revise, remove, or clarify proposed airworthiness criteria related to flightcrew interface requirements on the Model JAS4-1.

The FAA received comments requesting that the FAA replace the language in JS4.2600(a) and (b) with the language in § 23.2600(a) and (b). The Model JAS4-1 is capable of using one or more sources of lift to perform a particular phase of flight. Therefore, using the unchanged wording from § 23.2600(a) is not sufficient and does not include hover. JS4.2000 includes definitions for “sources of lift” and “phases of flight,” and those defined terms were used in proposed JS4.2600(a). The FAA included “without excessive concentration, skill, alertness, or fatigue” in proposed JS4.2600(b) to address the human factors elements used to control the aircraft. The Model JAS4-1 includes increased levels of automation and technology that may impact pilot concentration, alertness, and fatigue, so the inclusion of “without excessive concentration, skill, alertness, or fatigue” language is necessary. No changes were made as a result of these comments.

The FAA received a comment to restructure the header paragraph of JS4.2620 such that the manufacturer must present pertinent information for the aircraft for all possible configurations of thrust or flight. The FAA disagrees as the requirement is applicable to the overall aircraft and must contain information concerning aircraft configurations as necessary for defining the required information in JS4.2620. No change is necessary as a result of this comment.

One commenter requested clarification on procedures for the flightcrew following an abnormal battery anomaly. The FAA notes that JS4.2620(a)(5) addresses this concern by requiring information necessary for safe operation because of design, operating, or handling characteristics to be specified in the Airplane Flight Manual, which provides procedural guidance for flightcrew. Procedures following an abnormal battery anomaly are necessary for safe operation. No changes were made as a result of this comment.

One commenter requested that the FAA include JS4.2620(a)(5) as information that must be approved by the FAA. The FAA disagrees, as this requirement is consistent with the existing airworthiness standards for normal category aircraft. No changes were made as a result of this comment.

One commenter requested clarification on whether the requirements in JS4.1529 (ICA) and JS4.2615 (flight, navigation, and powerplant instruments) would also address EASA SC-VTOL.2445, Lift/thrust system installation information. Although the Model JAS4-1 airworthiness criteria do not contain a requirement that directly aligns with EASA’s SC-VTOL.2445, the commenter is correct that JS4.1529 and JS4.2615 address the lift/thrust installation requirements in EASA SC-VTOL.2445. In addition, the lift/thrust installation requirements in EASA SC-VTOL.2445 would be addressed for the Model JAS4-1 by the requirements in §§ 23.2605 and 23.2610.

The FAA received multiple comments to modify § 23.2605 to add a requirement that information related to safety equipment must be easily identifiable and its method of operation must be clearly marked, as specified in SC-VTOL.2605(d). The language requested by the commenters is already required by § 23.2535 and therefore no changes are necessary as a result of these comments.

One commenter requested the FAA revise JS4.2615(b)(2) to delete criteria for single failure and probability. The FAA does not agree and notes that this requirement is essential for CSFL after probable failures, both singular and in combination.

Electric Engines

The FAA received and reviewed comments from Airbus, EASA, GAMA, JCAB, Lilium, MTLs, Odys, Overair, Rolls-Royce, TCCA, Vertical Aerospace, Volocopter and an individual commenter requesting the FAA revise, remove, or clarify proposed airworthiness criteria related to electric engines for the Model JAS4-1.

One commenter recommended replacing the phrase “intended aircraft application” throughout subpart H with language specific to the Model JAS4-1 design. Another commenter recommended replacing “declared environmental limits” with “aircraft environmental and operating limitations” throughout subpart H. The FAA does not agree that more specific language is necessary, as “intended aircraft application” and “declared environmental limits” are sufficient to

meet the electric engine certification requirements. No changes were made as a result of these comments.

The FAA received comments recommending the removal of § 33.5 (a), (b), and (c) and § 33.29 from the engine requirements in Subpart H. One commenter stated these requirements should not be imposed for an engine that is not being type certificated as an independent product, as is the case for the Model JAS4-1. This commenter also stated the engines for the Model JAS4-1 are being certified under the umbrella of the aircraft type certificate; as a result, the installation and operating instructions will already be part of the type design data package at the aircraft level. Other commenters stated that no additional burden from individual “engine-only” requirements for data sheet content is necessary, from § 33.5(a), (b), and (c), JS4.2702, JS4.2706, JS4.2710(j)(2), JS4.2718(c) and (d), JS4.2719(b) and (e), and JS4.2733(d)(2). The FAA recognizes the engines will be approved with the Model JAS4-1 aircraft, but instructions for installing and operating the engines are required, as well as other engine airframe interfaces such as instruments, connections, sensors, etc., whether the engines are approved with the aircraft or certificated under their own type certificate. The FAA made no changes in response to these recommendations.

The FAA received comments on the applicability of subsystems equipment installed in an electric hybrid propulsion system (EHPS), as referenced in EASA Special Condition E-19 EHPS.330. The FAA acknowledges these comments but notes that they are not applicable to the Model JAS4-1, since the Joby engine architecture does not include the electric hybrid propulsion systems associated with E-19 EHPS.330.

One commenter questioned whether the requirements of EASA Special Condition E-19 EHPS.80, which accounts for the complete inability to isolate components that could cause a hazard to aircraft, should be added to airworthiness criteria for the Model JAS4-1. The FAA does not agree, as the requirement to isolate components that could cause a hazard to the aircraft is in EHPS.350(d), EHPS Control System, not in EHPS.80. The requirement in EHPS.350 raised by the commenter is addressed by JS4.2710 Engine Control Systems, JS4.2717 Safety Analysis, and JS4.2733 Engine Electrical Systems. Since the Joby JAS4-1 is a special class aircraft and the engines will be approved with the aircraft, the means by which components prevent a hazard from developing may be implemented

either at the engine-level or at the aircraft-level. No changes were made as a result of these comments.

Another commenter noted the proposed requirement to comply with § 33.75(e)(1) includes a reference to § 33.4 (ICA), although the proposed airworthiness criteria do not include a requirement to comply with § 33.4. The commenter recommended either removing the reference to § 33.4 or adding a reference to Appendix 1, §§ AJS4.2701, A33.2, A33.3, and A33.4. The FAA agrees with the comment. The FAA proposed JS4.2717 to include those safety analysis standards from § 33.75 that could not be required directly for the Model JAS4–1 without modification. Proposed JS4.2717(c) contained requirements for how the applicant must comply with § 33.75(e). The FAA has modified proposed JS4.2717(c) to reference the ICA in JS4.1529 for compliance with § 33.75(e)(1).

The FAA received a comment asking for clarification of the term “duty cycle” in JS4.2702(b). The FAA also received a comment to remove the requirement in JS4.2702(b) to list the duty cycle on the type certificate data sheet. The FAA disagrees. A duty cycle is intrinsic with engine ratings. Engine ratings are declared to support aircraft performance objectives, whereas duty cycles are an electric engine property that limits the usage of the ratings. The duty cycle, combined with the rating at that duty cycle, establishes the capability and the limits for engine usage. A commenter also noted that the takeoff power time limitation is not defined. A duty cycle and rating at each duty cycle must be declared, which covers this concern. No changes were made as a result of these comments.

The FAA received a comment to add specific operating limits to JS4.2702. The FAA also received a comment to add § 33.7(d) to the airworthiness criteria to address the accuracy of the engine control system and necessary instrumentation. Section 33.7(d) applies to engine performance and operating limitations. The FAA did not propose to require that the Model JAS4–1 comply with § 33.7(d), because § 33.7(d) focuses on engine control system components (e.g., speed sensors, actuators, feedback mechanisms) that typically operate using low voltage power and hydraulic systems. Electric engines, such as those that are part of the Model JAS4–1 design, are controlled differently. In addition, the Model JAS4–1 engine electrical systems are integrated with aircraft systems instruments that are necessary for control of the engine, which would not be addressed by § 33.7(d). Instead, for the Model JAS4–

1, the engine performance and operating limitations referenced by § 33.7(d) are addressed by the airworthiness criteria for the engine control system in JS4.2710 and the engine electrical system in JS4.2733. No changes were made as a result of these comments.

The FAA also received a comment that JS4.2702 provided a redundant definition of the engine ratings with that in § 33.8. The FAA disagrees. These two engine requirements accomplish different objectives. JS4.2702 establishes the engine’s ratings and limits, while § 33.8 ensures each rating applies to the lowest power that all engines of the same type may be expected to produce under the conditions used to determine that rating. No changes were made as a result of this comment.

A commenter suggested the FAA remove the word “turbine” from § 33.17(a), as it is not applicable to the Joby Model JAS4–1. The FAA notes that proposed JS4.2704, “Fire Protection,” was initially drafted to consider potential arc-fault-initiated fires occurring anywhere inside or outside the electric engine. However, the commenter highlighted that the second statement in § 33.17(a) specifically applies to internal fires in turbine engines and is not relevant to Joby engines. Consequently, the FAA has modified the airworthiness criteria to remove the applicability of § 33.17(a) to the Model JAS4–1 and add a new statement to JS4.2704 emphasizing the design and construction requirements to minimize the occurrence and spread of fire during normal operation and failure conditions. This modification results in JS4.2704 having two paragraphs, (a) and (b). This modification makes a suggestion by another commenter to change the title of the airworthiness criteria to “High Voltage Arc Faults and Fire Protection” inapplicable.

The FAA received a comment questioning the applicability of § 33.17(b) through (g), which address flammable fluids. The FAA notes that flammable fluids and flammable fluid storage components could be used in the Model JAS4–1 design. As such, the FAA finds these criteria applicable, and no changes were made.

The FAA received a comment that pass and fail criteria should be defined for the requirement in JS4.2705 to minimize the development of an unsafe condition in the engine and recommended using the criteria in JS4.2717(d)(2). The FAA does not concur. An unsafe condition is determined by a risk assessment and not solely by the hazards identified by the hazardous effects in JS4.2717(d)(2). No

changes were made as a result of this comment.

The FAA also received a comment to add “removal from service” to the maintenance actions in proposed JS4.2705. The FAA disagrees. The statement “removal from service” is appropriate to address simple engine designs that are life limited. However, this statement is not needed in the Model JAS4–1 airworthiness criteria because any maintenance involving a life limited engine is addressed by JS4.2729(b) and JS4.2713. No changes were made as a result of this comment.

The FAA received two comments requesting clarification regarding whether proposed JS4.2729 (b) allows the applicant the option of not performing the teardown inspection. The FAA clarifies that the agency intends JS4.2729(b) to require a teardown inspection except for any engine parts or components that cannot be torn down. The FAA has changed proposed JS4.2729(b) to clarify that it only applies to engine components where a teardown cannot be performed in a non-destructive manner.

A commenter requested clarification on the difference between the durability requirements of JS4.2705 and JS4.2726. JS4.2705 is criteria for durability requirements for design and construction of the engine, whereas JS4.2726 provides requirements for a durability demonstration. The FAA modified JS4.2726 to distinguish it from JS4.2705 by explaining its purpose, which is to establish when the initial maintenance is required.

A commenter questioned where the requirements in EASA’s E–19 EHPS.200 are captured. The FAA notes that § 33.23 establishes the loads associated with the engine mounting attachments and structure similar to what would be expected under EHPS.200 for an electric engine such as in the Model JAS4–1. No changes were made as a result of this comment.

Multiple commenters requested clarification on JS4.2709 concerning failure conditions leading to rotor overspeed. JS4.2709 was based on § 33.27 “Turbine, Compressor, Fan, and Turbosupercharger Rotor Overspeed.” The FAA intended the approach used for establishing the highest possible rotor overspeed in proposed JS4.2709 to be consistent with the approach in § 33.27(b), except for the prescriptive overspeed margins. The margins in § 33.27(b) are based on the physics of what drives the rotors in turbine engines and turbosupercharger rotors. The mechanisms that can drive electric engines to an overspeed condition are different from those that govern

combustion engines. No changes were made as a result of these comments.

One commenter suggested that JS4.2710(a) should refer to engine operations as well as engine tilting devices unless engine control systems are linked to one engine. The FAA notes that JS4.2710 addresses individual engines used in the Joby distributed propulsion system; however, the FAA identified an error in JS4.2710(j)(2), which was originally intended to cover all engine electrical systems, leading to confusion regarding the applicability in paragraph (a). The FAA clarifies that the engine control requirements in JS4.2710 apply to any aspects of the engine control that interface with aircraft control systems that are necessary for safe flight and landing. The FAA has corrected this error in the final criteria by removing the reference to electrical power supplied to the aircraft by energy regeneration from paragraph (j)(2).

One commenter recommended that the pertinent characteristics and capabilities of the Model JAS4-1 that the applicant must analyze should be prescriptively included in JS4.2710(g) and JS4.2717(e). The FAA does not agree that all the pertinent aircraft details that must be analyzed under JS4.2710(g) and JS4.2717(e) should be prescribed within the airworthiness criteria as existing aircraft airworthiness standards also do not prescribe these pertinent aircraft details. This guidance may be found in advisory circulars or industry consensus standards, which provide one means, but not the only means, for showing compliance with the existing regulatory requirements. These means will likely need to be modified to consider powered-lift designs such as the Model JAS4-1.

One commenter recommended that the FAA clarify that JS4.2710(i)(2) be applicable throughout the flight envelope. The FAA agrees that JS4.2710(i)(2), which requires the engine control system be able to detect and accommodate any single failure related to the aircraft-supplied data as specified in JS4.2710(i), is applicable throughout the flight envelope. However, the FAA did not make any changes as a result of this comment, as JS4.2710(d) already specifies that the engine control system must perform the intended functions, throughout the declared operational envelope. This includes the control system requirements in JS4.2710(i)(2) and will be captured as part of the aircraft's approved flight envelope.

The FAA received a comment to update JS4.2710(e) to declare the engine control system and the engine electrical environmental limits, similar to

JS4.2823(a)(2). This concern is already addressed by the airworthiness criteria. Since the engines are approved with the aircraft, environmental conditions and limits that were used to substantiate the Model JAS4-1 aircraft and its engines will be used to develop compliance with JS4.2620, "Aircraft Flight Manual." No changes were made to JS4.2710(e) as a result of this comment. However, this comment revealed a need to clarify the requirement in proposed JS4.2727. The purpose of JS4.2727 is to supplement engine testing with additional component-level and systems-level tests that expose engine components and systems to operational conditions that cannot not be achieved in the engine test environment or with the specified test duration. Also, demonstration shortfalls for certain electrical properties might occur with other engine tests, such as the durability demonstration, because the test duration required to show deterioration in electrical hardware may be impracticable.

One commenter requested the FAA remove proposed JS4.2711(b)(2), which specifies that the aircraft design is not required to enable the flight crew to monitor the engine cooling system for a cooling system failure that would not result in a hazardous engine effect. The FAA disagrees. Removing proposed JS4.2711(b)(2) would result in a requirement for instrumentation enabling the flightcrew to monitor the engine cooling system regardless of the hazard level resulting from a cooling system failure. Although monitoring the engine cooling system would enable the crew to respond to leading indicators to an overheated engine and prevent the aircraft from the subsequent effects, the severity of the effects from an overheated engine, and the appropriate engine-level protection and mitigation standards are addressed by the engine safety analysis. No changes were made as a result of the comment.

One commenter suggested changing the word "electromagnetic" to "electrical" in proposed JS4.2712(a). The FAA does not concur with this change, as electrical system hazards are covered in JS4.2733. However, the FAA acknowledges that the requirement in proposed JS4.2712(a) could be clarified and made changes to that effect.

Multiple commenters recommended adding the demonstration to operate above temperature limits on turbine engines for short-duration ratings in JS4.2724, and to consider updating JS4.2709 and JS4.2730 to add the requirements in E-19 EHPS.250(a), "the failure of any rotating component or part of an equipment, electric engine or

generator must not lead to the release of high energy debris." The FAA has revised JS4.2724 to remove its applicability to all engine ratings and also revised the introductory text of JS4.2730 to be more aligned with part 33 subpart B. The FAA did not find the recommended language appropriate for JS4.2709 and did not make any changes to JS4.2709.

The FAA received a comment asking for clarification on whether JS4.2715(c) only applies to engines having torque operating limitations. JS4.2715(c) applies to an electric engine regardless of whether the engine is torque limited. Joby can propose ratings and limits in accordance with JS4.2702 using relevant engine parameters such as horsepower, torque, rotational speed, and temperature. JS4.2715 and JS4.2725 require tests that range from ground idle and flight idle, to the rated power or thrust prescribed by these rules. Electric engines can create torque much faster than combustion engines, and sudden changes in torque could present a hazard to the aircraft installation. Therefore, the power response characteristics must account the intended aircraft application to ensure the torque characteristics of the engine and intended aircraft are compatible. These requirements correspond to § 33.73 and § 33.89 respectively, so the minimum torque or power settings are established in the procedures that assess the operational capabilities of the electric engines. The FAA modified proposed JS4.2715(c) to clarify that this is an engine-level requirement.

One commenter requested the FAA consider EASA's Special Condition E-19 EHPS.260. The commenter states that proposed JS4.2716 only addresses hazardous engine effects and applicants should evaluate, as required by EHPS.260, the effects of any continued rotation on the system, such as windmilling propellers. The concerns raised by the commenter are addressed by JS4.2733, "Engine Electrical Systems." JS4.2733(b) (both proposed and final) ensures that the generation and transmission of electrical power, and electrical load shedding, do not result in any unacceptable engine operating characteristics or cause the engine to exceed its operating limits. New JS4.2733 (e)(2) requires the characteristics of any electrical power supplied from the engine to the aircraft via energy regeneration to be identified and declared in the engine installation manual.

One commenter requested clarification on the applicability of JS4.2717(a) and (c). The FAA notes that JS4.2717(a) is necessary because

§ 33.75(a)(1) and (a)(2), which are required as part of these airworthiness criteria, refer to hazardous engine effects as defined in § 33.75(g). Similarly, JS4.2717(c) is necessary because § 33.75(d) and (e), which are required as part of these airworthiness criteria, also refer to hazardous engine effects. When showing compliance with § 33.75(a)(1), (a)(2), (d), and (e), Joby must use the definitions in JS4.2717(d) in lieu of the definitions in § 33.75(g), as stated in JS4.2717(a) and (c). No changes were made as a result of this comment.

The FAA received multiple comments to change the proposed definition of a minor engine effect in JS4.2717(d)(1). The commenters recommended using the criteria in § 33.75(g)(1) to classify the effects of a partial or total loss of engine power in the Model JAS4–1. The Model JAS4–1 engine airworthiness criteria do not classify the engine effect from a complete loss of engine power because the aircraft level assumptions are different than those used in § 33.75(g)(1). The Model JAS4–1 engine airworthiness criteria allow a complete loss of power in one engine to be classified based on the effects on the aircraft. No changes were made as a result of these comments.

Multiple commenters stated that due to the integrated nature of the Model JAS4–1, the system safety analyses required in support of § 23.2510 are adequate and sufficient, and that § 33.75, JS4.2717, and JS4.2733(f) and (g) should be removed from these airworthiness criteria. The FAA does not agree with this recommendation, and notes that § 23.2510 establishes the safety objective for aircraft systems and equipment “whose failure or abnormal operation has not been specifically addressed by another requirement.” The proposed subpart H and I requirements include specific engine and propeller design and testing requirements not covered under aircraft-level airworthiness criteria and establish a minimum level of safety equivalent to the existing part 33 and part 35 airworthiness standards as required under § 21.17(b). Additionally, these airworthiness criteria prescribe the same requirements for installed engines and propellers on the Model JAS4–1 that would apply to these engines and propellers if they received separate type certificates under parts 33 and 35, respectively. The aircraft-level requirements of § 23.2510 are not sufficient on their own to ensure engines and propellers will meet the intended level of safety required by § 21.17(b) for parts 33 and 35. Since the engines will be approved with the Joby aircraft, these compliance details may

be documented in the appropriate aircraft-level documents with references to the engine-level requirements in Subpart H.

One commenter recommended removing the prescriptive airworthiness criteria of subparts H and I and to defer their development to the means of compliance. Another commenter proposed to use performance-based aircraft requirements that consign the engines and propellers to aircraft equipment or systems and relegate engine and propeller certification requirements to a means of compliance to an aircraft requirement. The FAA does not agree with these comments and considers the requirements in subparts H and I to provide an equivalent level of safety for the Model JAS4–1. No changes were made as a result of these comments.

A commenter requested the FAA reword proposed JS4.2717(d)(1) to remove an extraneous phrase “does not prohibit the engine from meeting its type-design requirements.” The FAA concurs that the phrase was unclear and updated JS4.2717(d)(1) for clarity.

A commenter requested clarification regarding why blockage of a cooling system as described in JS4.2717(d)(2)(ii) is considered a hazardous engine effect. The FAA notes that the blockage of a cooling system is not by itself a hazardous engine condition, but it could contribute to the development of one. Accordingly, the FAA modified JS4.2717(d)(2)(ii).

A commenter requested the FAA align JS4.2713 with the safety expectations in EASA’s SC–VTOL. The commenter recommended changing JS4.2713 to specify that no single failure may lead to a catastrophic event and to exclude the criteria for critical parts. The FAA does not find the level of safety outlined in SC–VTOL for “Category Enhanced” to be applicable to the Model JAS4–1 engine failure classifications, which could be minor, major, or hazardous, but not catastrophic. The FAA will apply failure classifications that are consistent with those established in part 33 to provide the equivalent level of safety required by § 21.17(b). No changes were made as a result of this comment.

A commenter requested clarification as to whether JS4.2713 would require the same activity for both critical parts and life-limited parts. An engineering plan, manufacturing plan, and service management plan will be needed for critical parts and for life-limited parts as stated in JS4.2713(b).

Commenters requested the FAA clarify what is meant by the definition of a “life limited part” in proposed

JS4.2713(a)(2), as it includes phrases that make it open-ended and indistinguishable from the definition of a critical part in JS4.2713(a)(1). The FAA agrees regarding the need for clarification in the definition of life-limited parts. While retaining the examples in the definition, the FAA has revised the definition of life-limited part in JS4.2713(a)(2) to be distinguished by the failure mode related to low-cycle fatigue mechanisms. The revised definition specifies that life-limited parts may involve rotors or major structural static parts, among other parts with failure potentially leading to hazardous engine effects due to low-cycle fatigue mechanisms.

A commenter noted that the FAA made a reference to § 33.70 in proposed JS4.2713(b) when § 33.70 was not included as a part of the Model JAS4–1 airworthiness criteria and recommended adding § 33.70. The FAA agrees and § 33.70(a), (b), and (c) have been added to the airworthiness criteria. The introductory paragraph of § 33.70, however, is not part of the airworthiness criteria.

A commenter also requested that the FAA specifically address high-cycle fatigue (HCF) effects in JS4.2713. HCF effects are included in the life limit calculation under § 33.70. The influence of HCF on life limits is addressed as part of the vibration requirement in JS4.2720, which characterizes and quantifies all vibration stresses in a part. It also requires the vibration stresses to be less than the material endurance limits, when combined with steady stresses. No changes were made as a result of this comment.

A commenter noted that the FAA has historically not applied the classification of “critical part” in FAA airworthiness standards and asked for clarification. The use of critical parts is consistent with the FAA’s certification approach for electric engines and is necessary for an acceptable level of safety. No changes were made as a result of this comment.

One commenter questioned why the FAA included transient maximum overtemperature and transient maximum overspeed as part of the endurance demonstration in proposed JS4.2721. The FAA notes that electric engines typically establish power or thrust ratings using shaft torque. Therefore, torque is managed directly, or by another governing parameter, such as electrical current. The airworthiness criteria in JS4.2721 are performance-based, but the applicant may use the procedures in § 33.84(a) as a means of compliance with the overtorque requirement. Transient rotor speed in

electric and combustion engines is controlled by different technologies. Transient overspeed in a combustion engine is typically a design feature that allows an engine to exceed a maximum steady state rotor speed temporarily in order to meet certain performance requirements. Electric engines use electrical current and have fast response times, so transient rotor overspeed is not typically needed to meet performance requirements and would most likely occur from a failure or design flaw, which are occurrences within the scope of JS4.2721. No changes were made as a result of this comment.

The FAA received a comment requesting clarity on the endurance demonstration requirement in JS4.2723(b). The FAA notes that the endurance demonstration is an accelerated severity test intended to demonstrate the engine has acceptable performance characteristics throughout the operating range, up to and including engine ratings and operating limits without the need for maintenance after being exposed to these extreme conditions. Therefore, the engine cycles that are used for the endurance demonstration do not correlate well with the engine cycles that are used during in-service operation. The FAA concurs with the commenter that additional clarification is needed and modified JS4.2723(b) to require that the endurance demonstration must be for a duration sufficient to verify the limit capabilities of the engine.

One commenter identified a need for clarification regarding electromagnetic stresses in proposed JS4.2712, "Stress Analysis," which also corresponds to § 33.62. The FAA has updated JS4.2712(a) to address the interaction between electrical systems and magnetic components, specifically considering electromagnetic forces, which are not covered in existing airworthiness standards for aircraft engines. The revised paragraph (a) requires a comprehensive stress analysis, including mechanical, thermal, and electromagnetic forces, to ensure an adequate design margin that prevents hazardous engine effects and unacceptable operating characteristics.

Another commenter requested that the FAA add "at the declared operating limits" to proposed JS4.2712(a). The FAA does not concur. JS4.2712 includes mechanical, thermal, and electromagnetic stress. These criteria were created to account for design limits specific to electric engines that, if exceeded, could develop into hazardous engine conditions. The airworthiness criteria ensure design margins account for any relevant declared operating

limits. No changes were made as a result of this comment.

A commenter asked for clarification of the term "minimum material properties" in JS4.2712(b). JS4.2712(b) requires determining maximum stresses in the engine without exceeding minimum material properties. The Model JAS4-1 must comply with § 33.15, which establishes the requirements for engine materials. Compliance with § 33.15 will determine "minimum material properties." No changes were made as a result of this comment.

One commenter proposed that the FAA consider that the single fault tolerance criteria in proposed JS4.2710(f)(2) be understood at the aircraft "propulsion system level" rather than at the engine level when addressing Loss of Power Control (LOPC). Commenters requested similar clarification regarding the single fault criteria in proposed JS4.2733(f)(2). The FAA disagrees that the requested change would be appropriate. The airworthiness criteria in Subpart H apply to a single engine, not to the entire distributed propulsion system. No changes were made to the airworthiness criteria in response to this comment.

Multiple commenters requested that the FAA qualitatively and quantitatively define LOPC in the airworthiness criteria. The FAA does not agree. The LOPC airworthiness criteria for the Model JAS4-1 are contained in portions of § 33.28 and JS4.2710. Existing engine airworthiness standards in part 33 do not prescribe the level of detail requested by the commenters. LOPC will depend on the performance data and system analysis for the Model JAS4-1 and its intended aircraft application. No changes were made as a result of these comments.

One commenter noted that § 33.28(d)(4) effectively requires that the engine control system be resilient to local events, while the proposed airworthiness criteria in JS4.2710(f)(4) does not allow local events to occur. The commenter requested the FAA revise JS4.2710(f)(4) to maintain the safety intent of § 33.28(d)(4). The FAA agrees with the suggested change. JS4.2710(f)(4) has been changed to require the engine control system to "ensure failures or malfunctions that lead to local events in the aircraft do not result in hazardous engine effects as defined in JS4.2717(d)(2) due to engine control system failures or malfunctions."

One commenter proposed that the FAA differentiate between the ingestions that must not lead to a hazardous event (such as a large bird

impact) and the ones that cannot lead to a loss of power that would become incompatible with the aircraft performances and CSFL capabilities. Another commenter questioned the use of the broad term "foreign objects" in JS4.2718. The FAA modified JS4.2718 to incorporate ingestion sources identified in §§ 33.68, 33.76, 33.77, and 33.78. Revised JS4.2718 uses general terminology when distinguishing abnormal operation, hazardous engine effects, and unacceptable power loss which accounts for aircraft level effects and clarifies the term "foreign objects" by specifying the ingestion source.

Multiple commenters requested clarification regarding applicability differences between § 33.28 and JS4.2710. The FAA notes that the applicability of both requirements is covered by JS4.2710(a). The FAA intends the applicant to employ the elements of § 33.28 specified as applicable to the Model JAS4-1 in combination with the additional requirements of JS4.2710.

One commenter asked if compliance with § 33.64 is necessary to satisfy the proposed pressurized cooling requirements in § 33.21 and JS4.2706, as stated in ASTM Standard F3338-21 section 5.7.4. The ASTM Standard applies to liquid engine cooling systems, but the requirements in § 33.21 and JS4.2706 apply to air and liquid engine cooling systems. The FAA notes that although § 33.64, which contains requirements for pressurized engine static parts, is not part of the Joby airworthiness criteria, the concern raised in this comment is addressed by other Joby airworthiness criteria. Pressurized engine static parts are addressed by JS4.2719. Paragraph (a) specifies requirements for liquid systems used for lubrication or cooling engine components. Paragraph (c) includes airworthiness criteria for static parts subjected to pressurized liquid systems. The FAA also revised the heading of JS4.2719 from "Liquid Systems" to "Liquid and Gas Systems" to clarify the applicability of the requirement and to differentiate it from ASTM Standard F3338-21.

Another commenter requested the FAA clarify that § 33.29(f), which requires a safety assessment of incorrect fit of instruments, sensors, or connectors, applies to the Model JAS4-1. The FAA disagrees and notes that § 33.29(f) references a § 33.75 turbine engine safety analysis that is not relevant to the Joby electric engines. The airworthiness criteria have been revised to exclude paragraph (f) from the requirement to comply with certain paragraphs of § 33.29.

The same commenter requested the FAA generalize the terminology in JS4.2728 to recognize electro-mechanical implementations in addition to traditional mechanisms and functions. The commenter proposed replacing “locking” with “holding” and “unlocking” with “release.” JS4.2728 does not prescribe specific implementation of the rotor lock, other than the prevention of the rotor from turning. A rotor locking (or holding) function in an electric engine could have both mechanical and electro-mechanical purposes. The FAA determined the criteria in JS4.2728 will achieve the intended objectives for the Model JAS4–1. No changes are necessary as a result of the comment.

A commenter questioned the use of service limits in determining acceptability during the teardown evaluation in proposed JS4.2729(a)(1), as the service limits can be lower than those demonstrated as a part of the certification process. The FAA agrees that the intent is that each engine part must conform to the type design and be eligible for incorporation into an engine for continued operation and updated JS4.2729(a)(1) to remove the reference to service limits.

The FAA received multiple comments asking to define or qualify what would be an acceptable margin for purposes of JS4.2730(a) and whether a rotor burst analysis is required at the aircraft level. The FAA disagrees. The FAA will determine an acceptable margin similar to the way the agency determines acceptable margins for engines under part 33. No changes were made as a result of these comments.

In regard to compliance with the functional demonstrations required by JS4.2731, a commenter asked whether there will be a basic standard test-run program, or whether the demonstration will depend on the individual case. The FAA notes that JS4.2731 uses performance-based language to describe the functional demonstrations if they are not accomplished concurrent with other required engine tests. Currently, there are no industry-wide accepted standards for conducting electric engine tests with variable pitch propellers, so the demonstration will depend on the individual case.

A commenter requested the FAA merge JS4.2733(c)(1), which addresses the electrical-power distribution system, and JS4.2733(d)(1), which addresses protection systems. Paragraph (c) addresses the safe transfer of power throughout the power plant whereas paragraph (d) addresses a protection system’s response to power conditions that exceed design limits. These systems

perform different functions, and therefore they are treated by separate airworthiness criteria. No changes were made as a result of the comment.

The same commenter noted that the type of electrical fault isolation required in JS4.2733(c)(3) should be linked to the possible effects of the fault on the safety of flight and the aircraft. JS4.2733(c) protects engine electrical systems from faulted electrical energy generation or storage devices. The means of compliance should be tied to the safety assessment, which includes aircraft-level effects from faulted electrical-energy generation or storage device. The FAA updated JS4.2733(c)(3) to recognize this link.

A commenter questioned the numbering scheme of the airworthiness criteria in proposed JS4.2733(d). The FAA agrees that the numbering scheme needed better clarity. JS4.2733(d)(1) was merged with the introductory text of JS4.2733(d). Proposed JS4.2733(d)(2) does not fit under Protection Systems and was moved to JS4.2733(e). Proposed JS4.2733(e) through (g) have been renumbered as JS4.2733(f) through (h).

The same commenter noted that proposed JS4.2733(d) was too prescriptive in specifically requiring transmission interruption. The FAA agrees and changed the language to reflect that the Model JAS4–1 must be designed such that certain conditions would not result in a hazardous engine effect.

Lastly, the commenter requested that the FAA revise proposed JS4.2733(e), which addresses environmental limits, to make it less prescriptive. The commenter suggested that proposed JS4.2733(e) contain similar language as that in the equivalent requirement for the propeller control system in JS4.2823(a)(2). The FAA disagrees. JS4.2733(e) and JS4.2823(a)(2) are not equivalent requirements as stated by the commenter. Proposed JS4.2733(e) (JS4.2733(f) in these final criteria) requires demonstrating environmental limits through system and component tests when substantiation methods are insufficient, while JS4.2823(a)(2) requires ensuring propeller control system functionality remains unaffected by declared environmental conditions and documenting validated environmental limits in propeller manuals. No changes were made as a result of this comment.

Propellers

The FAA received and reviewed comments from ALPA, Airbus, ASDIA, EASA, GAMA, Hartzell, Overair, TCCA, and Volocopter requesting the FAA revise, remove, or clarify proposed

airworthiness criteria related to propellers for the Model JAS4–1.

Multiple commenters requested changes to proposed JS4.2823 regarding the causal direction of hazardous propeller effects and local events. One commenter suggested that “local event” needs to be defined. The FAA concurs and has revised JS4.2823(b)(2) to require that local events not cause hazardous propeller effects. The FAA also concurs that the definition of “local events,” in the context of JS4.2823, should be as defined as it is in AC 33.28–3, “Guidance Material for 14 CFR § 33.28, Engine Control Systems,” with minor wording changes that are appropriate for the Model JAS4–1. The FAA has added this definition to JS4.2000(b)(6).

Another commenter noted that two requirements from § 35.23 were missing in the proposed airworthiness criteria for the Model JAS4–1 and suggested that they be added. The FAA concurs and added § 35.23(b)(3) and 35.23(b)(4) to the airworthiness criteria as paragraphs JS4.2823(b)(3) and JS4.2823(b)(4).

Additionally, commenters suggested that the number of propeller pitch cycles be increased from thirteen hundred to fifteen hundred in proposed JS4.2840(a) to align it with § 35.40(b). The FAA agrees and has revised JS4.2840(a) accordingly.

One commenter asked why the functional test in proposed JS4.2840 is limited to forward pitch and not to the entire pitch range. The FAA notes that the test is limited because the Model JAS4–1 does not have reversible pitch capability.

Several commenters requested the FAA elaborate on how the FAA differentiated between requirements for rotors compared to propellers, and whether icing ingestion requirements are needed for propellers. The FAA does not concur with suggestions to add additional requirements for lift generating rotors or ice ingestion requirements for the JS4.2800 series criteria. The design and the expected failure modes of Joby’s propellers are expected to be similar to conventional propellers type certificated under part 35 despite being used in the vertical thrust mode. Ice ingestion requirements for the engines already exist in other parts of the Model JAS4–1 airworthiness criteria.

Commenters suggested that proposed JS4.2815, which requires a safety analysis of the propeller system, is inadequate because the rate of hazardous propeller effects was not conservative enough and propeller release and unbalance should be treated as catastrophic events and not as hazardous propeller effects. Further,

commenters suggested that determining the rate of hazardous propeller effects should be less ambiguous. The FAA does not concur with the suggestion that the acceptable hazardous propeller failure rate is too high. The criteria are derived from part 35 requirements, which provide an acceptable level of safety for both part 23 and 25 airplanes. The FAA does not concur with the suggestion that propeller release and unbalance should be treated as catastrophic and not hazardous effects. Catastrophic effects are treated at the aircraft level and the criteria for single propellers provide an acceptable level of safety. The FAA does not concur with the request to make the quantitative prediction of a hazardous propeller effect less ambiguous due to inherent limitations on the availability of reliable data.

One commenter questioned the need for a propeller critical part designation. The FAA does not concur with the suggestion to not make the propellers critical parts. The critical part requirements are integral for creating a propeller with an equivalent level of safety and are retained for the Model JAS4-1.

Commenters suggested that the current § 35.35 centrifugal load requirements are inappropriately prescriptive and that overspeed requirements derived from parts 27 or 29 rotorcraft rules are more appropriate. The FAA does not concur with the suggestion to substitute rotorcraft overspeed requirements for the propeller centrifugal load tests in § 35.35(a) and (b) because the design and failure modes of Joby's propellers are expected to be similar to conventional propellers type certificated under part 35. The consequential propeller loads are expected to primarily be centrifugal loads, and therefore the prescriptive centrifugal test requirement of § 35.35, with its requirement for a large margin of safety, is needed to ensure an equivalent level of safety.

A commenter requested clarification on the requirements in § 35.36 and whether it includes secondary impact hazards on other aircraft systems or personnel. The § 35.36 airworthiness standard requires that the propeller must withstand a 4-lb bird impact without major or hazardous effects. This prohibits the release of the propeller or any major portion of the propeller, which could result in secondary impact hazards on other aircraft systems or personnel, or result in an excessive imbalance. No changes were made as a result of this comment.

A commenter stated that the propeller-specific lightning strike requirements of § 35.38, which prevent major or hazardous effects, are inconsistent with aircraft-level lightning requirement in JS4.2335, which prevents catastrophic effects. The commenter proposed modifying the airworthiness criteria to remove the inconsistency. The FAA disagrees. The propeller requirements prescribe a particular safety level for an uninstalled propeller only; an uninstalled propeller does not need the same safety requirement as the aircraft. The aircraft safety analysis uses the propeller failure rate data to show that the aircraft will not experience any catastrophic effects. No changes were made as a result of this comment.

One commenter requested a definition for maximum propeller overspeed and overtorque as used in § 35.41. The FAA does not concur with the request to define propeller overspeed or overtorque because the applicant defines these ratings, if applicable, to show compliance with JS4.2805 and § 35.41. No changes were made as a result of this comment.

Another commenter requested a definition of acceptable "propellers of similar design" for purposes of compliance with JS4.2840(c). By a propeller of "similar design" in JS4.2840(c), the FAA means that expected failure modes, materials, construction, normal operating characteristics, and features of the propeller are unchanged or have only insignificant differences compared to another propeller. No changes were made as a result of this comment.

Requests To Include Additional Criteria

The FAA received comments from Airbus, ALPA, ANAC, ASDIA, CAAC, EASA, GAMA, JCAB, Lilium, Martin Aerotech, MTLs, TCCA, and individual commenters that additional criteria should be added for the Model JAS4-1 powered-lift.

One commenter requested the FAA provide reasoning on the omission of § 23.2005, which defines certification levels for normal category airplanes based on maximum seating configuration and speed, or an equivalent airworthiness criterion. The commenter requested the FAA discuss how the agency is establishing the minimum safety requirements for various special class powered-lift products to provide an equivalent level of safety. The FAA did not include § 23.2005 in these airworthiness criteria as that regulation was developed specifically for part 23 airplanes. The Model JAS4-1 is a powered-lift with

novel flight phases that are not representative of airplanes; instead, the FAA is establishing a level of safety for the Model JAS4-1 that is equivalent with the level of safety in both part 23 and part 27 for airplanes and rotorcraft performing similar operations. Additionally, the criteria in this notice are specific for the Model JAS4-1 and are not generally applicable to powered-lift of various sizes.

An individual requested more criteria for HIRF environment applied to urban air mobility operations and vertiports. The FAA notes JS4.2520(a), HIRF protection, requires compliance for systems associated with catastrophic failure conditions. No changes were made as a result of this comment.

Several commenters requested the FAA require provisions for in-service monitoring such as a Health and Usage Monitoring System to validate assumptions pertaining to airframe structure designs. The FAA is charged under § 21.17(b) to provide an equivalent level of safety to the existing airworthiness standards. The FAA does not currently require in-service monitoring for critical parts on other aircraft types, and the FAA does not plan to require any provisions for in-service monitoring of critical parts for powered-lift. No changes were made as a result of this comment.

Several commenters noted that no specific requirement is mentioned for aircraft batteries and recommended the FAA create new, specific criteria to address topics such as fire protection, fire propagation, crashworthiness, high-voltage current disconnection, protection from lightning transients, punctures and leakage of toxic gas or liquid, and effects of temperature and battery health on battery performance. The FAA acknowledges the risk posed by these hazards but does not agree that additional specific requirements are necessary. All risks identified are adequately addressed by the requirements of Subparts E and F, JS4.1529, and the Appendix A ICA requirements for airframe, engines, and propellers, with specific safety objectives and means of compliance to address these risks that will be developed and tailored to the specific aspects of the Model JAS4-1 powered-lift.

Out of Scope Comments

The FAA received and reviewed numerous comments that were general, stated the commenter's viewpoint or opposition without a suggestion specific to the proposed criteria, did not make a request the FAA can act on, requested clarification on existing airworthiness

standards, requested changes or clarification to means of compliance, requested changes to type certification procedures defined in 14 CFR part 21, requested requirements for features not included on the Model JAS4–1, improperly assumed the Model JAS4–1 was an Unmanned Aircraft System, addressed issues covered by operational requirements including IFR under which the Model JAS4–1 will not be operating or other 14 CFR parts not related to airworthiness, or asked generalized questions about the Model JAS4–1 powered-lift. These comments are beyond the scope of this document. The FAA also reviewed several comments relating to the pursuit of future rulemaking for powered-lift, which is beyond the scope of these airworthiness criteria.

Additional Changes Made to the Proposed Criteria

From October 31, 2023, through November 2, 2023, the FAA met with representatives from the European Union Aviation Safety Agency (EASA) regarding the proposed airworthiness criteria. This discussion did not pertain specifically to the Model JAS4–1, but instead concerned harmonization activities between EASA and FAA on the requirements and means of compliance for type certification of powered-lift/VTOL aircraft generally. As a result of this meeting, and for consistency with the harmonized general criteria, the FAA changed the proposed requirement to comply with § 23.2250(c). The FAA added the sentence “The applicant must prevent single failures from resulting in a catastrophic effect upon the aircraft” to § 23.2250(c) (now JS4.2250(c)) to clarify that while single point failures are allowed in the design, they must be prevented from resulting in a catastrophic effect on the aircraft.

Applicability

These airworthiness criteria, established under the provisions of § 21.17(b), are applicable to the Joby Model JAS4–1 powered-lift. Should Joby apply at a later date for a change to the type certificate to include another model, these airworthiness criteria would apply to that model as well, provided the FAA finds them appropriate in accordance with the requirements of subpart D to part 21.

Conclusion

This action affects only certain airworthiness criteria for the Model JAS4–1 powered-lift. It is not a standard of general applicability.

Authority Citation

The authority citation for these airworthiness criteria is as follows: Authority: 49 U.S.C. 106(g), 40113, 44701–44702, 44704.

Airworthiness Criteria

Pursuant to the authority delegated to me by the Administrator, the following airworthiness criteria are issued as part of the type certification basis for the Model JAS4–1 powered-lift. The FAA finds these criteria to be appropriate for the aircraft and applicable to the specific type design and provide an equivalent level of safety to existing airworthiness standards.

Aircraft-Level Requirements

§ 23.1457 Cockpit Voice Recorders

(a) through (g) [Applicable to Model JAS4–1]

§ 23.1459 Flight Data Recorders

(a) through (e) [Applicable to Model JAS4–1]

JS4.1529 Instructions for Continued Airworthiness

The applicant must prepare Instructions for Continued Airworthiness (ICA), in accordance with Appendices A, A1, and A2, that are acceptable to the Administrator. ICA for the aircraft, engines, and propellers may be shown in a single aircraft ICA manual if the engine and propeller approvals are sought through the aircraft certification program. Alternatively, the applicant may provide individual ICA for the aircraft, engines, and propellers. The instructions may be incomplete at the time of type certification if a program exists to ensure their completion prior to delivery of the first aircraft, or issuance of a standard certificate of airworthiness, whichever occurs later.

Subpart A—General

JS4.2000 Applicability and Definitions

(a) These airworthiness criteria prescribe airworthiness standards for the issuance of a type certificate, and changes to that type certificate, for the Joby Aero, Inc. Model JAS4–1 powered-lift. This aircraft must be certificated in accordance with either the “essential performance” or “increased performance” requirements of these airworthiness criteria. This aircraft may also be type certificated as both “essential performance” and “increased performance” with appropriate and different operating limitations for each approval.

(b) For purposes of these airworthiness criteria, the following definitions apply:

(1) *Continued safe flight and landing*—

(i) for powered-lift approved for “essential performance” means the aircraft is capable of continued controlled flight and landing, possibly using emergency procedures, without requiring exceptional pilot skill, strength, or alertness.

(ii) for powered-lift approved for “increased performance” means the aircraft is capable of climbing to a safe altitude, on a flightpath clear of obstacles, and maintaining level flight to a planned destination or alternate landing, possibly using emergency procedures, without requiring exceptional pilot skill, strength, or alertness.

(2) *Phases of flight* means ground operations, takeoff, climb, cruise, descent, approach, hover, and landing.

(3) *Source of lift* means one of three sources of lift: thrust-borne, wing-borne, and semi-thrust-borne. Thrust-borne is defined as when the weight of the aircraft is principally supported by lift generated by engine-driven lift devices. Wing-borne is defined as when the weight of the aircraft is principally supported by aerodynamic lift from fixed airfoil surfaces. Semi-thrust-borne is the combination of thrust-borne and wing-borne, where both forms of lift are used to support the weight of the aircraft.

(4) *Controlled emergency landing* means the aircraft design retains the capability to allow the pilot to choose the direction and area of touchdown while reasonably protecting occupants from serious injury. Upon landing, some damage to the aircraft may be acceptable.

(5) *Critical change of thrust* means the most adverse effect on performance or handling qualities resulting from failures of the flight control or propulsive system, either singular or in combination, not shown to be extremely improbable.

(6) *Local events* are failures of aircraft systems and components, other than the engine and propeller control system, that may affect the installed environment of the engine and propeller control system.

(c) Terms used in the part 23, part 33, and part 35 provisions that are adopted in these airworthiness criteria will have the following meaning:

“Airplane” means “aircraft.”

“This part” means “these airworthiness criteria.”

“Rotorcraft” means “aircraft.”

§ 23.2010 Accepted Means of Compliance

(a) through (b) [Applicable to Model JAS4-1]

Subpart B—Flight Performance**§ 23.2100 Weight and Center of Gravity**

(a) through (c) [Applicable to Model JAS4-1]

JS4.2105 Performance Data

(a) Unless otherwise prescribed, the aircraft must meet the performance requirements of this subpart in still air and standard atmospheric conditions.

(b) Unless otherwise prescribed, the applicant must develop the performance data required by this subpart for the following conditions:

(1) Altitudes from sea level to the maximum altitude for which certification is being sought; and

(2) Temperatures above and below standard day temperature that are within the range of operating limitations, if those temperatures could have a negative effect on performance.

(c) The procedures used for determining takeoff and landing performance must be executable consistently by pilots of average skill in atmospheric conditions expected to be encountered in service.

(d) Performance data determined in accordance with paragraph (b) of this section must account for losses due to atmospheric conditions, cooling needs, installation losses, downwash considerations, and other demands on power sources.

(e) The hovering ceiling, in and out of ground effect, must be determined over the ranges of weight, altitude, and temperature, if applicable.

(f) Continued safe flight and landing must be possible from any point within the approved flight envelope following a critical change of thrust.

(g) The aircraft must be capable of a controlled emergency landing, following a condition when the aircraft can no longer provide the commanded power or thrust required for continued safe flight and landing, by gliding or autorotation, or an equivalent means to mitigate the risk of loss of power or thrust.

JS4.2110 Minimum Safe Speed

The applicant must determine the aircraft minimum safe speed for each flight condition encountered in normal operations, including applicable sources of lift and phases of flight, to maintain controlled safe flight. The minimum safe speed determination must account

for the most adverse conditions for each flight configuration.

JS4.2115 Takeoff Performance

(a) The applicant must determine takeoff performance accounting for:

(1) All sources of lift for each takeoff flight path for which certification is sought,

(2) Minimum safe speed safety margins,

(3) Minimum control speeds, and

(4) Climb requirements.

(b) For aircraft approved for essential performance, the applicant must determine the takeoff performance to 50 feet above the takeoff surface such that a rejected takeoff resulting in safe stop or landing can be made at any point along the takeoff flight path following a critical change of thrust.

(c) For aircraft approved for increased performance, the applicant must determine the takeoff performance so that—

(1) Following a critical change of thrust prior to reaching the takeoff decision point, a rejected takeoff resulting in a safe stop or landing can be made. The takeoff decision point may be a speed, an altitude, or both; and

(2) Following a critical change of thrust after passing the takeoff decision point, the aircraft can—

(i) Continue the takeoff and climb to 50 feet above the takeoff surface; and

(ii) Subsequently achieve the configuration and airspeed used in compliance with JS4.2120.

JS4.2120 Climb Requirements

(a) The applicant must demonstrate minimum climb performance at each weight, altitude, and ambient temperature within the operating limitations using the procedures published in the flight manual.

(b) For aircraft approved for essential and increased performance, the applicant must determine the following all engines operating (AEO) climb performance requirements:

(1) A steady climb gradient at sea level of at least 8.3 percent in the initial takeoff configuration(s) and a climb speed selected by the applicant or V_y , and

(2) For a balked landing, a climb gradient of 3 percent without creating undue pilot workload with the landing gear extended and flaps in the landing configuration(s).

(c) For aircraft approved for essential performance, the climb performance after a critical change of thrust must be determined—

(1) Using applicable sources of lift along the takeoff flight path for which certification is being sought at the

speeds and configurations selected by the applicant; and

(2) For the transition from the takeoff to the enroute configuration. The total altitude loss must be determined for the weight, altitude, and ambient temperature where level flight cannot be maintained.

(d) For aircraft approved for increased performance, the climb performance after a critical change of thrust must be such that—

(1) In thrust-borne and semi-thrust-borne flight:

(i) The steady rate of climb without ground effect, 200 feet above the takeoff surface, is at least 100 feet per minute,

(ii) The steady rate of climb without ground effect, 1,000 feet above the takeoff surface, is at least 150 feet per minute,

(iii) The steady rate of climb (or descent) enroute is determined in feet per minute, at each weight, altitude, and temperature at which the aircraft is expected to operate for which certification is requested.

(2) In wing-borne flight, the steady gradient of climb:

(i) During takeoff at the takeoff surface, is at least 0.5 percent with the aircraft in its takeoff configuration(s),

(ii) During takeoff at 400 feet above the takeoff surface, is at least 2.6 percent with the aircraft in its second segment configuration,

(iii) Enroute at 1,500 feet above the takeoff or landing surface, as appropriate, is at least 1.7 percent with the aircraft in a cruise configuration, and

(iv) During a discontinued approach at 400 feet above the landing surface, is not less than 2.7 percent in an approach configuration.

(e) The applicant must determine the performance accordingly for the appropriate sources of lift for gliding, autorotation, or the equivalent means established under JS4.2105(g).

JS4.2125 Climb Information

(a) The applicant must determine climb performance at each weight, altitude, and ambient temperature within the operating limitations using the procedures published in the flight manual.

(b) The applicant must determine climb performance accounting for any critical change of thrust.

JS4.2130 Landing

The applicant must determine the following, for standard temperatures at critical combinations of weight and altitude within the operational limits:

(a) The approach and landing speeds and procedures, which allow a pilot of

average skill to land within the published landing distance consistently and without causing damage or injury, and which allow for a safe transition to the balked landing conditions of these airworthiness criteria accounting for:

- (1) All sources of lift for each approach and landing flight path for which certification is sought,
- (2) Any minimum or maximum speed safety margins, and
- (3) Minimum control speeds.

(b) For aircraft approved for essential performance, the applicant must determine the landing performance from a height of 50 feet above the landing surface. Additionally, the aircraft must be capable of performing a safe landing at any point along the approach flight path following a critical change of thrust.

(c) For aircraft approved for increased performance, the applicant must determine the landing performance from a height of 50 feet above the landing surface so that, following a critical change of thrust that occurs prior to the landing decision point, the aircraft can—

- (1) Land and stop safely on the landing surface; or
- (2) Transition to the balked landing condition and performance established in JS4.2120.

Flight Characteristics

JS4.2135 Controllability

(a) The aircraft must be controllable and maneuverable, without requiring exceptional piloting skill, alertness, or strength, within the approved flight envelope—

- (1) At all loading conditions for which certification is requested;
- (2) During all phases of flight while using applicable sources of lift;
- (3) With likely flight control or propulsion system failure;
- (4) During configuration changes;
- (5) In all degraded flight control system operating modes not shown to be extremely improbable;
- (6) In thrust-borne operation, and must be controllable in wind velocities from zero to at least 17 knots from any azimuth angle; and
- (7) The aircraft must be able to safely complete a landing using the steepest approach gradient procedures.

(b) The applicant must determine critical control parameters, such as limited control power margins, and if applicable, account for those parameters in appropriate operating limitations.

(c) It must be possible to make a smooth transition from one flight condition to another (changes in configuration and in source of lift and

phase of flight) without exceeding the approved flight envelope.

JS4.2140 Trim

(a) The aircraft must maintain lateral and directional trim without further force upon, or movement of, the primary flight controls or corresponding trim controls by the pilot, or the flight control system, under all normal operations while using applicable sources of lift.

(b) The aircraft must maintain longitudinal trim without further force upon, or movement of, the primary flight controls or corresponding trim controls by the pilot, or the flight control system, under the following conditions:

- (1) Climb.
- (2) Level flight.
- (3) Descent.
- (4) Approach.

(c) Residual control forces must not fatigue or distract the pilot during normal operations of the aircraft and likely abnormal or emergency operations, including a critical change of thrust.

JS4.2145 Stability

(a) The aircraft must exhibit static stability characteristics inclusive of likely failures.

(b) The aircraft must exhibit suitable short period dynamic stability inclusive of likely failures.

(c) For wing borne and semi-thrust-borne operations:

(1) No aircraft may exhibit any divergent longitudinal dynamic stability characteristics so unstable as to increase the pilot's workload or otherwise endanger the aircraft and its occupants, and

(2) The aircraft must exhibit lateral-directional dynamic stability inclusive of likely failures.

(d) For thrust borne operations, no aircraft may exhibit any divergent dynamic stability characteristics so unstable as to increase the pilot's workload or otherwise endanger the aircraft and its occupants.

JS4.2150 Minimum Safe Speed Characteristics and Warning

(a) When part of the lift is generated from a fixed wing, the aircraft must have controllable stall characteristics in straight flight, turning flight, and accelerated turning flight with a clear and distinctive stall warning that provides sufficient margin to prevent inadvertent stalling and not have a tendency to inadvertently depart controlled safe flight.

(b) For other sources of lift, the aircraft must have controllable

characteristics in straight flight, turning flight, and accelerated turning flight with a clear and distinctive warning that provides sufficient margin to prevent inadvertent departures from controlled safe flight.

(c) For all sources of lift, the aircraft must not have the tendency to inadvertently depart controlled safe flight after a sudden change of thrust.

§ 23.2155 Ground and Water Handling Characteristics

[Applicable to Model JAS4–1]

JS4.2160 Vibration, Buffeting, and High-Speed Characteristics

(a) Each part of the aircraft must be free from excessive vibration and buffeting under each appropriate speed and power condition. Vibration and buffeting, for operations up to V_D/M_D , must not interfere with the control of the aircraft or cause excessive fatigue to the flightcrew. Stall warning buffet within these limits is allowable.

(b) For inadvertent excursions beyond the maximum approved speed, the aircraft must be able to safely recover back to its approved flight envelope without requiring exceptional piloting skill, strength, or alertness. This recovery may not result in structural damage or loss of control.

JS4.2165 Performance and Flight Characteristics Requirements for Flight in Atmospheric Icing Conditions

(a) The applicant must provide a means to detect icing conditions for which certification is not requested and show the aircraft's ability to avoid or exit those icing conditions.

(b) The applicant must develop an operating limitation to prohibit intentional flight, including takeoff and landing, into icing conditions for which the aircraft is not certified to operate.

Subpart C—Structures

JS4.2200 Structural Design Envelope

The applicant must determine the structural design envelope, which describes the range and limits of aircraft design and operational parameters for which the applicant will show compliance with the requirements of this subpart. The applicant must account for all aircraft design and operational parameters that affect structural loads, strength, durability, and aeroelasticity, including:

(a) Structural design airspeeds, landing descent speeds, and any other airspeed limitation at which the applicant must show compliance to the requirements of this subpart. The structural design airspeeds must—

(1) Be sufficiently greater than the minimum safe speed of the aircraft to safeguard against loss of control in turbulent air; and

(2) Provide sufficient margin for the establishment of practical operational limiting airspeeds.

(b) Design maneuvering load factors not less than those, which service history shows, may occur within the structural design envelope.

(c) Inertial properties including weight, center of gravity, and mass moments of inertia, accounting for—

(1) Each critical weight from the aircraft empty weight to the maximum weight; and

(2) The weight and distribution of occupants, payload, and energy-storage systems.

(d) Characteristics of aircraft control systems, including range of motion and tolerances for control surfaces, high lift devices, or other moveable surfaces.

(e) Each critical altitude up to the maximum altitude.

(f) Engine-driven lifting-device rotational speed and ranges, and the maximum rearward and sideward flight speeds.

(g) Thrust-borne, wing-borne, and semi-thrust-borne flight configurations, with associated flight load envelopes.

§ 23.2205 Interaction of Systems and Structures

[Applicable to Model JAS4–1]

Structural Loads

§ 23.2210 Structural Design Loads

(a) through (b) [Applicable to Model JAS4–1]

JS4.2215 Flight Load Conditions

(a) The applicant must determine the structural design loads resulting from the following flight conditions:

(1) Atmospheric gusts where the magnitude and gradient of these gusts are based on measured gust statistics.

(2) Symmetric and asymmetric maneuvers.

(3) Asymmetric thrust resulting from the failure of a powerplant unit.

(b) There must be no vibration or buffeting severe enough to result in structural damage, at any speed up to dive speed, within the structural design envelope, in any configuration and power setting.

§ 23.2220 Ground and Water Load Conditions

[Applicable to Model JAS4–1]

JS4.2225 Component Loading Conditions

The applicant must determine the structural design loads acting on:

(a) Each engine mount and its supporting structure such that both are designed to withstand loads resulting from—

(1) Powerplant operation combined with flight gust and maneuver loads; and

(2) For non-reciprocating powerplants, sudden powerplant stoppage.

(b) Each flight control and high-lift surface, their associated system and supporting structure resulting from—

(1) The inertia of each surface and mass balance attachment;

(2) Flight gusts and maneuvers;

(3) Pilot or automated system inputs;

(4) System induced conditions, including jamming and friction; and

(5) Taxi, takeoff, and landing operations on the applicable surface, including downwind taxi and gusts occurring on the applicable surface.

(c) [Reserved]

(d) Engine-driven lifting-device assemblies, considering loads resulting from flight and ground conditions, as well limit input torque at any lifting-device rotational speed.

§ 23.2230 Limit and Ultimate Loads

(a) through (b) [Applicable to Model JAS4–1]

Structural Performance

§ 23.2235 Structural Strength

(a) through (b) [Applicable to Model JAS4–1]

JS4.2240 Structural Durability

(a) The applicant must develop and implement inspections or other procedures to prevent structural failures due to foreseeable causes of strength degradation, which could result in serious or fatal injuries, or extended periods of operation with reduced safety margins. Each of the inspections or other procedures developed under this section must be included in the Airworthiness Limitations Section of the ICA, required by JS4.1529.

(b) If safety-by-design (fail-safe) is used to comply with paragraph (a) of this section, safety-by-inspection (damage tolerance) must also be incorporated to reliably detect structural damage before the damage could result in structural failure.

(c) The aircraft must be designed to minimize hazards to the aircraft due to structural damage caused by high-energy fragments from an uncontained engine or rotating machinery failure.

JS4.2241 Aeromechanical Stability

The aircraft must be free from dangerous oscillations and aeromechanical instabilities for all

configurations and conditions of operation on the ground and in flight.

JS4.2245 Aeroelasticity

(a) The aircraft must be free from flutter, control reversal, and divergence—

(1) At all speeds within and sufficiently beyond the structural design envelope;

(2) For any configuration and condition of operation;

(3) Accounting for critical structural modes, and

(4) Accounting for any critical failures or malfunctions.

(b) The applicant must establish tolerances for all quantities that affect aeroelastic stability.

(c) Each component and rotating aerodynamic surface of the aircraft must be free from any aeroelastic instability under each appropriate speed and power condition.

Design

JS4.2250 Design and Construction Principles

(a) The applicant must design each part, article, and assembly for the expected operating conditions of the aircraft.

(b) Design data must adequately define the part, article, or assembly configuration, its design features, and any materials and processes used.

(c) The applicant must determine the suitability of each design detail and part having an important bearing on safety in operations. The applicant must prevent single failures from resulting in a catastrophic effect upon the aircraft.

(d) The control system must be free from jamming, excessive friction, and excessive deflection when the aircraft is subjected to expected limit airloads.

(e) Doors, canopies, and exits must be protected against inadvertent opening in flight, unless shown to create no hazard when opened in flight.

§ 23.2255 Protection of Structure

(a) through (c) [Applicable to Model JAS4–1]

§ 23.2260 Materials and Processes

(a) through (g) [Applicable to Model JAS4–1]

§ 23.2265 Special Factors of Safety

(a) through (c) [Applicable to Model JAS4–1]

Structural Occupant Protection

§ 23.2270 Emergency Conditions

(a) through (e) [Applicable to Model JAS4–1]

Subpart D—Design and Construction**JS4.2300 Flight Control Systems**

(a) The applicant must design flight control systems to:

- (1) Operate easily, smoothly, and positively enough to allow proper performance of their functions;
- (2) Protect against likely hazards; and
- (3) Ensure that the flightcrew is made suitably aware whenever the means of primary flight control approaches the limits of control authority.

(b) The applicant must design trim systems or trim functions, if installed, to:

- (1) Protect against inadvertent, incorrect, or abrupt trim operation; and
- (2) Provide information that is required for safe operation.

(c) Features that protect the aircraft against loss of control or exceeding critical limits must be designed such that there are no adverse flight characteristics in aircraft response to flight-control inputs, unsteady atmospheric conditions, and other likely conditions, including simultaneous limiting events.

§ 23.2305 Landing Gear Systems

(a) through (c) [Applicable to Model JAS4–1]

JS4.2311 Bird Strike

The aircraft must be capable of continued safe flight and landing after impact with a 2.2-lb (1.0 kg) bird.

Occupant System Design Protection**JS4.2315 Means of Egress and Emergency Exits**

(a) With the cabin configured for takeoff or landing, the aircraft is designed to:

- (1) Facilitate rapid and safe evacuation of the aircraft in conditions likely to occur following an emergency landing.
- (2) Have means of egress (openings, exits, or emergency exits), that can be readily located and opened from the inside and outside. The means of opening must be simple and obvious and marked inside and outside the aircraft.
- (3) Have easy access to emergency exits when present.

(b) [Reserved]

§ 23.2320 Occupant Physical Environment

(a) and (c) [Applicable to Model JAS4–1]

(b), (d), and (e) [Not applicable to Model JAS4–1]

Fire and High Energy Protection**JS4.2325 Fire Protection**

(a) The following materials must be self-extinguishing—

- (1) Insulation on electrical wire and electrical cable; and
 - (2) Materials in the baggage and cargo compartments inaccessible in flight.
- (b) The following materials must be flame resistant—

- (1) Materials in each compartment accessible in flight; and
 - (2) Any equipment associated with any electrical cable installation and that would overheat in the event of circuit overload or fault.
- (c) Thermal/acoustic materials in the fuselage, if installed, must not be a flame propagation hazard.
- (d) Sources of heat within each baggage and cargo compartment that are capable of igniting adjacent objects must be shielded and insulated to prevent such ignition.

(e) Each baggage and cargo compartment must—

- (1) Be located where a fire would be visible to the pilots and be accessible for the manual extinguishing of a fire,
- (2) Be equipped with a smoke or fire detection system that warns the pilot, or
- (3) Be constructed of, or lined with, fire resistant materials.

(f) There must be a means to extinguish any fire in the cabin such that the pilot, while seated, can easily access the fire extinguishing means.

(g) Each area where flammable fluids or vapors might escape by leakage of a fluid system must—

- (1) Be defined; and
- (2) Have a means to minimize the probability of fluid and vapor ignition, and the resultant hazard, if ignition occurs.

JS4.2330 Fire Protection in Fire Zones and Adjacent Areas

(a) Flight controls, engine mounts, and other flight structures within or adjacent to fire zones must be capable of withstanding the effects of a fire.

(b) Engines in a fire zone must remain attached to the aircraft in the event of a fire.

(c) In fire zones, terminals, equipment, and electrical cables used during emergency procedures must perform their intended function in the event of a fire.

JS4.2335 Lightning and Static Electricity Protection

(a) The aircraft must be protected against catastrophic effects from lightning.

(b) The aircraft must be protected against hazardous effects caused by an accumulation of electrostatic charge.

Subpart E—Powerplant**JS4.2400 Powerplant Installation**

(a) For the purpose of this subpart, the aircraft powerplant installation must include each component necessary for propulsion, which affects propulsion safety.

(b) Each aircraft engine and propeller must be approved under the aircraft type certificate using standards found in subparts H and I.

(c) The applicant must construct and arrange each powerplant installation to account for—

- (1) Likely operating conditions, including foreign-object threats;
- (2) Sufficient clearance of moving parts to other aircraft parts and their surroundings;
- (3) Likely hazards in operation including hazards to ground personnel; and
- (4) Vibration and fatigue.

(d) Hazardous accumulations of fluids, vapors, or gases must be isolated from the aircraft and personnel compartments and be safely contained or discharged.

(e) Powerplant components must comply with their component limitations and installation instructions or be shown not to create a hazard.

JS4.2405 Power or Thrust Control Systems

(a) Any power or thrust control system or powerplant control system must be designed so no unsafe condition results during normal operation of the system.

(b) Any single failure or likely combination of failures or malfunctions of a power or thrust control system or powerplant control system must not prevent continued safe flight and landing of the aircraft.

(c) Inadvertent flightcrew operation of a power or thrust control system or powerplant control system must be prevented, or if not prevented, must not prevent continued safe flight and landing of the aircraft.

§ 23.2410 Powerplant Installation Hazard Assessment

(a) through (c) [Applicable to Model JAS4–1]

§ 23.2415 Powerplant Ice Protection

(a) through (b) [Applicable to Model JAS4–1]

JS4.2425 Powerplant Operational Characteristics

(a) Each installed powerplant must operate without any hazardous characteristics during normal and emergency operation within the range of

operating limitations for the aircraft and the engine.

(b) The design must provide for the shutdown and restart of the powerplant in flight within an established operational envelope.

JS4.2430 Energy Systems

(a) Each energy system must—

(1) Be designed and arranged to provide independence between multiple energy-storage and supply systems, so that failure of any one component in one system will not result in loss of energy storage or supply of another system;

(2) Be designed to prevent catastrophic events due to lightning strikes, taking into account direct and indirect effects on the aircraft;

(3) Provide the energy necessary to ensure each powerplant functions properly in all likely operating conditions;

(4) Provide the flightcrew with a means to determine the total useable energy available and provide uninterrupted supply of that energy when the system is correctly operated, accounting for likely energy fluctuations;

(5) Provide a means to safely remove or isolate the energy stored in the system from the aircraft; and

(6) Be designed to retain energy under all likely operating conditions and to minimize hazards to occupants and first responders following an emergency landing or otherwise survivable impact (crash landing).

(b) Each energy-storage system must—

(1) Withstand the loads under likely operating conditions without failure; and

(2) Be isolated from personnel compartments and protected from likely hazards.

(c) Each energy-storage recharging system must be designed to—

(1) Prevent improper recharging; and

(2) Prevent the occurrence of hazard to the aircraft or to persons during recharging.

JS4.2440 Powerplant Fire Protection

There must be means to isolate and mitigate hazards to the aircraft in the event of a powerplant system fire or overheat in operation.

Subpart F—Equipment

§ 23.2500 Airplane Level Systems Requirements

(a) through (b) [Applicable to Model JAS4–1]

§ 23.2505 Function and Installation

[Applicable to Model JAS4–1]

§ 23.2510 Equipment, Systems, and Installations

(a) through (c) [Applicable to Model JAS4–1]

JS4.2515 Electrical- and Electronic-System Lightning Protection

(a) Each electrical or electronic system that performs a function, the failure of which would prevent the continued safe flight and landing of the aircraft, must be designed and installed such that—

(1) The function at the aircraft level is not adversely affected during and after the time the aircraft is exposed to lightning; and

(2) The system recovers normal operation of that function in a timely manner after the aircraft is exposed to lightning unless the system's recovery conflicts with other operational or functional requirements of the system.

(b) For an aircraft approved for operation under instrument flight rules (IFR), each electrical and electronic system that performs a function, the failure of which would reduce the capability of the aircraft or the ability of the flightcrew to respond to an adverse operating condition, must be designed and installed such that the system recovers normal operation of that function in a timely manner after the aircraft is exposed to lightning.

JS4.2520 High-Intensity Radiated Fields (HIRF) Protection

(a) Each electrical or electronic system that performs a function, the failure of which would prevent the continued safe flight and landing of the aircraft, must be designed and installed such that—

(1) The function at the aircraft level is not adversely affected during and after the time the aircraft is exposed to the HIRF environment; and

(2) The system recovers normal operation of that function in a timely manner after the aircraft is exposed to the HIRF environment, unless the system's recovery conflicts with other operational or functional requirements of the system.

(b) For aircraft approved for IFR operations, each electrical and electronic system that performs a function, the failure of which would reduce the capability of the aircraft or the ability of the flightcrew to respond to an adverse operating condition, must be designed and installed such that the system recovers normal operation of that function in a timely manner after the aircraft is exposed to the HIRF environment.

§ 23.2525 System Power Generation, Storage, and Distribution

(a) through (c) [Applicable to Model JAS4–1]

§ 23.2530 External and Cockpit Lighting

(a) through (d) [Applicable to Model JAS4–1]

(e) [Not applicable to Model JAS4–1]

§ 23.2535 Safety Equipment

[Applicable to Model JAS4–1]

§ 23.2545 Pressurized Systems Elements

[Applicable to Model JAS4–1]

§ 23.2550 Equipment Containing High-Energy Rotors

[Applicable to Model JAS4–1]

Subpart G—Flightcrew Interface and Other Information

JS4.2600 Flightcrew Interface

(a) The pilot compartment, its equipment, and its arrangement to include pilot view, must allow each pilot to perform their duties for all sources of lift and phases of flight and perform any maneuvers within the approved flight envelope of the aircraft, without excessive concentration, skill, alertness, or fatigue.

(b) The applicant must install flight, navigation, surveillance, and powerplant controls and displays, as needed, so qualified flightcrew can monitor and perform defined tasks associated with the intended functions of systems and equipment, without excessive concentration, skill, alertness, or fatigue. The system and equipment design must minimize flightcrew errors, which could result in additional hazards.

§ 23.2605 Installation and Operation

(a) through (c) [Applicable to Model JAS4–1]

§ 23.2610 Instrument Markings, Control Markings, and Placards

(a) through (c) [Applicable to Model JAS4–1]

JS4.2615 Flight, Navigation, and Powerplant Instruments

(a) Installed systems must provide the flightcrew member who sets or monitors parameters for the flight, navigation, and powerplant, the information necessary to do so during each source of lift and phase of flight. This information must—

(1) Be presented in a manner that the crewmember can monitor the parameter and determine trends, as needed, to operate the aircraft; and

(2) Include limitations, unless the limitations cannot be exceeded in all intended operations.

(b) Indication systems that integrate the display of flight or powerplant parameters to operate the aircraft, or are required by the operating rules of title 14, chapter I, must—

(1) Not inhibit the primary display of flight or powerplant parameters needed by any flightcrew member in any normal mode of operation; and

(2) In combination with other systems, be designed and installed so information essential for continued safe flight and landing will be available to the flightcrew in a timely manner after any single failure or probable combination of failures.

JS4.2620 Aircraft Flight Manual

The applicant must provide an Aircraft Flight Manual that must be delivered with each aircraft.

(a) The Aircraft Flight Manual must contain the following information—

(1) Aircraft operating limitations;

(2) Aircraft operating procedures;

(3) Performance information;

(4) Loading information; and

(5) Other information that is necessary for safe operation because of design, operating, or handling characteristics.

(b) The portions of the Aircraft Flight Manual containing the information specified in paragraphs (a)(1) through (a)(4) of this section must be approved by the FAA in a manner specified by the Administrator.

Subpart H—Electric Engine Requirements

§ 33.5 Instruction Manual for Installing and Operating the Engine

(a) through (c) [Applicable to Model JAS4–1]

§ 33.7 Engine Ratings and Operating Limitations

(a) [Applicable to Model JAS4–1]

(b) through (d) [Not applicable to Model JAS4–1]

JS4.2702 Engine Ratings and Operating Limits

Ratings and operating limits must be established and included in the type certificate data sheet based on:

(a) Shaft power, torque, rotational speed, and temperature for:

(1) Rated takeoff power;

(2) Rated maximum continuous power; and

(3) Rated maximum temporary power and associated time limit.

(b) Duty cycle and the rating at that duty cycle. The duty cycle must be declared in the type certificate data sheet.

(c) Cooling fluid grade or specification.

(d) Power-supply requirements.

(e) Any other ratings or limitations that are necessary for the safe operation of the engine.

§ 33.8 Selection of Engine Power and Thrust Ratings

(a) through (b) [Applicable to Model JAS4–1]

§ 33.15 Materials

(a) through (b) [Applicable to Model JAS4–1]

§ 33.17 Fire Protection

(a) [Not applicable to Model JAS4–1]

(b) through (g) [Applicable to Model JAS4–1]

JS4.2704 Fire Protection

(a) The design and construction of the engine and the materials used must minimize the probability of the occurrence and spread of fire during normal operation and failure conditions and must minimize the effect of such a fire.

(b) High-voltage electrical wiring interconnect systems must be protected against arc faults that can lead to hazardous engine effects as defined in JS4.2717(d)(2). Non-protected electrical wiring interconnects must be analyzed to show that arc faults do not cause a hazardous engine effect.

JS4.2705 Durability

The engine design and construction must minimize the development of an unsafe condition of the engine between maintenance intervals, overhaul periods, or mandatory actions described in the applicable ICA.

§ 33.21 Engine Cooling

[Applicable to Model JAS4–1]

JS4.2706 Engine Cooling

If cooling is required to satisfy the safety analysis as described in JS4.2717, the cooling-system monitoring features and usage must be documented in the engine installation manual.

§ 33.23 Engine Mounting Attachments and Structure

(a) through (b) [Applicable to Model JAS4–1]

§ 33.25 Accessory Attachments

[Applicable to Model JAS4–1]

JS4.2709 Overspeed

(a) A rotor overspeed must not result in a burst, rotor growth, or damage that results in a hazardous engine effect, as defined in JS4.2717(d)(2). Compliance with this paragraph must be shown by

test, validated analysis, or a combination of both. Applicable assumed rotor speeds must be declared and justified.

(b) Rotors must possess sufficient strength with a margin to burst above approved operating conditions and above failure conditions leading to rotor overspeed. The margin to burst must be shown by test, validated analysis, or a combination thereof.

(c) The engine must not exceed the rotor-speed operational limitations that could affect rotor structural integrity.

§ 33.28 Engine Control Systems

(b)(1)(i), (b)(1)(iii), and (b)(1)(iv)

[Applicable to Model JAS4–1]

(a), (b)(1)(ii), and (b)(2) through (m) [Not applicable to Model JAS4–1]

JS4.2710 Engine Control Systems

(a) Applicability.

These requirements apply to any system or device that is part of the engine type design that controls, limits, monitors, or protects engine operation and is necessary for the continued airworthiness of the engine.

(b) Engine control.

The engine control system must ensure the engine does not experience any unacceptable operating characteristics or exceed its operating limits, including in failure conditions where the fault or failure results in a change from one control mode to another, from one channel to another, or from the primary system to the back-up system, if applicable.

(c) Design assurance.

The software and complex electronic hardware, including programmable logic devices, must be—

(1) Designed and developed using a structured and systematic approach that provides a level of assurance that the logic commensurate with the hazard associated with the failure or malfunction of the systems in which the devices are located; and

(2) Substantiated by a verification methodology acceptable to the Administrator.

(d) Validation.

All functional aspects of the control system must be substantiated by test, analysis, or a combination thereof, to show that the engine control system performs the intended functions throughout the declared operational envelope.

(e) Environmental limits.

Environmental limits that cannot be adequately substantiated by endurance demonstration, validated analysis, or a combination thereof must be demonstrated by the system and component tests in JS4.2727.

(f) Engine control system failures.

The engine control system must—

(1) Have a maximum rate of Loss of Power Control (LOPC) that is suitable for the intended aircraft application. The estimated LOPC rate must be specified in the engine installation manual;

(2) When in the full-up configuration, be single fault tolerant, as determined by the Administrator, for electrical, electrically detectable, and electronic failures involving LOPC events;

(3) Not have any single failure that results in hazardous engine effects as defined in JS4.2717(d)(2); and

(4) Ensure failures or malfunctions that lead to local events in the aircraft do not result in hazardous engine effects as defined in JS4.2717(d)(2) due to engine control system failures or malfunctions.

(g) System safety assessment.

The applicant must perform a system safety assessment. This assessment must identify faults or failures that affect normal operation, together with the predicted frequency of occurrence of these faults or failures. The intended aircraft application must be taken into account to assure the assessment of the engine control system safety is valid.

(h) Protection systems.

The engine control devices and systems' design and function, together with engine instruments, operating instructions, and maintenance instructions, must ensure that engine operating limits that can lead to a hazard will not be exceeded in-service.

(i) Aircraft-supplied data.

Any single failure leading to loss, interruption, or corruption of aircraft-supplied data (other than power command signals from the aircraft), or aircraft-supplied data shared between engine systems within a single engine or between fully independent engine systems, must—

(1) Not result in a hazardous engine effect, as defined in JS4.2717(d)(2), for any engine installed on the aircraft; and

(2) Be able to be detected and accommodated by the control system.

(j) Engine control system electrical power.

(1) The engine control system must be designed such that the loss, malfunction, or interruption of the control system electrical power source will not result in a hazardous engine effect, as defined in JS4.2717(d)(2), the unacceptable transmission of erroneous data, or continued engine operation in the absence of the control function. The engine control system must be capable of resuming normal operation when aircraft-supplied power returns to within the declared limits.

(2) The applicant must identify and declare, in the engine installation manual, the characteristics of any electrical power supplied from the aircraft to the engine control system, including transient and steady-state voltage limits, and any other characteristics necessary for safe operation of the engine.

§ 33.29 Instrument Connection

(a), (e), and (g) [Applicable to Model JAS4–1]

(b) through (d), (f), and (h) [Not applicable to the Model JAS4–1]

JS4.2711 Instrument Connection

(a) In addition, as part of the system safety assessment of JS4.2710(g) and JS4.2733(h), the applicant must assess the possibility and subsequent effect of incorrect fit of instruments, sensors, or connectors. Where practicable, the applicant must take design precautions to prevent incorrect configuration of the system.

(b) The applicant must provide instrumentation enabling the flightcrew to monitor the functioning of the engine cooling system unless evidence shows that:

(1) Other existing instrumentation provides adequate warning of failure or impending failure;

(2) Failure of the cooling system would not lead to hazardous engine effects, as defined in JS4.2717(d)(2), before detection; or

(3) The probability of failure of the cooling system is extremely remote.

JS4.2712 Stress Analysis

(a) A mechanical and thermal stress analysis, as well as an analysis of the stress caused by electromagnetic forces, must show a sufficient design margin to prevent unacceptable operating characteristics and hazardous engine effects as defined in JS4.2717(d)(2).

(b) Maximum stresses in the engine must be determined by test, validated analysis, or a combination thereof, and must be shown not to exceed minimum material properties.

§ 33.70 Engine Life Limited Parts

Introductory paragraph [Not applicable to Model JAS4–1]

(a) through (c) [Applicable to Model JAS4–1]

JS4.2713 Critical and Life-Limited Parts

(a) The applicant must show, by a safety analysis or means acceptable to the Administrator, whether rotating or moving components, bearings, shafts, static parts, and non-redundant mount components should be classified,

designed, manufactured, and managed throughout their service life as critical or life-limited parts.

(1) *Critical part* means a part that must meet prescribed integrity specifications to avoid its primary failure, which is likely to result in a hazardous engine effect as defined in JS4.2717(d)(2).

(2) *Life-limited parts* may include but are not limited to a rotor and major structural static part, the failure of which can result in a hazardous engine effect, as defined in JS4.2717(d)(2), due to low-cycle fatigue.

(b) In establishing the integrity of each critical part or life-limited part, the applicant must provide to the Administrator the following three plans for approval: an engineering plan, a manufacturing plan, and a service-management plan, as defined in § 33.70.

JS4.2714 Lubrication System

(a) The lubrication system must be designed and constructed to function properly between scheduled maintenance intervals in all flight attitudes and atmospheric conditions in which the engine is expected to operate.

(b) The lubrication system must be designed to prevent contamination of the engine bearings and lubrication system components.

(c) The applicant must demonstrate by test, validated analysis, or a combination thereof, the unique lubrication attributes and functional capability of paragraphs (a) and (b) of this section.

JS4.2715 Power Response

The design and construction of the engine, including its control system, must enable an increase—

(a) From the minimum power setting to the highest rated power without detrimental engine effects;

(b) From the minimum obtainable power while in flight, and while on the ground, to the highest rated power within a time interval determined to be appropriate for the intended aircraft application; and

(c) From the minimum torque to the highest rated torque without detrimental engine effects in the intended aircraft application.

JS4.2716 Continued Rotation

If the design allows any of the engine main rotating systems to continue to rotate after the engine is shut down while in-flight, this continued rotation must not result in hazardous engine effects, as specified in JS4.2717(d)(2).

§ 33.75 Safety Analysis

(a)(1) through (a)(2), (d), (e), and (g)(2) [Applicable to Model JAS4–1]

(a)(3) through (c), (f), (g)(1), and (g)(3) [Not applicable to Model JAS4-1]

JS4.2717 Safety Analysis

(a) The applicant must comply with § 33.75(a)(1) and (2) using the failure definitions in paragraph (d) of this section.

(b) The primary failure of certain single elements cannot be sensibly estimated in numerical terms. If the failure of such elements is likely to result in hazardous engine effects as defined in paragraph (d)(2) of this section, then the applicant may show compliance by reliance on the prescribed integrity requirements such as § 33.15, JS4.2709, JS4.2713, or combinations thereof, as applicable. The failure of such elements and associated prescribed integrity requirements must be stated in the safety analysis.

(c) The applicant must comply with § 33.75(d) using the failure definitions in paragraph (d) of this section, with § 33.75(e)(1) using the ICA in JS4.1529 Appendix 1, and with § 33.75(e)(4) using the failure definitions in paragraph (d) of this section.

(d) Unless otherwise approved by the Administrator, the following definitions apply to the engine effects when showing compliance with these airworthiness criteria:

(1) A minor engine effect does not prohibit the engine from performing its intended functions in a manner consistent with § 33.28(b)(1)(i), (b)(1)(iii), and (b)(1)(iv), and the engine complies with the operability requirements such as JS4.2715, JS4.2725, and JS4.2731, as appropriate.

(2) The engine effects in § 33.75(g)(2) are hazardous engine effects, as are:

(i) Electrocution of the crew, passengers, operators, maintainers, or others; and

(ii) Blockage of cooling systems that could cause the engine effects described in § 33.75(g)(2) and paragraph (d)(2)(i) of this section.

(3) Any other engine effect is a major engine effect.

(e) The intended aircraft application must be taken into account to assure that the analysis of the engine system safety is valid.

JS4.2718 Ingestion

(a) Rain, ice, and hail ingestion must not result in an abnormal operation such as shutdown, power loss, erratic operation, or power oscillations throughout the engine operating range.

(b) Ingestion from other likely sources (birds, induction system ice, foreign objects—ice slabs) must not result in hazardous engine effects, as defined in

JS4.2717(d)(2), or unacceptable power loss.

(c) If the design of the engine relies on features, attachments, or systems that the installer may supply, for the prevention of unacceptable power loss or hazardous engine effects as defined in JS4.2717(d)(2) following potential ingestion, then the features, attachments, or systems must be documented in the engine installation manual.

(d) Ingestion sources described in paragraph (b) of this section that are not evaluated must be declared in the engine installation manual.

JS4.2719 Liquid and Gas Systems

(a) Each system used for lubrication or cooling of engine components must be designed and constructed to function properly in all flight attitudes and atmospheric conditions in which the engine is expected to operate.

(b) If a system used for lubrication or cooling of engine components is not self-contained, the interfaces to that system must be defined in the engine installation manual.

(c) The applicant must establish by test, validated analysis, or a combination of both, that all static parts subject to significant pressure loads will not:

(1) Exhibit permanent distortion beyond serviceable limits or exhibit leakage that could create a hazardous condition when subjected to normal and maximum working pressure with margin.

(2) Exhibit fracture or burst when subjected to the greater of maximum possible pressures with margin.

(d) Compliance with paragraph (c) of this section must take into account:

(1) The operating temperature of the part;

(2) Any other significant static loads in addition to pressure loads;

(3) Minimum properties representative of both the material and the processes used in the construction of the part; and

(4) Any adverse physical geometry conditions allowed by the type design, such as minimum material and minimum radii.

(e) Approved coolants and lubricants must be listed in the engine installation manual.

JS4.2720 Vibration Demonstration

(a) The engine must be designed and constructed to function throughout its normal operating range of rotor speeds and engine output power, including defined exceedances, without inducing excessive stress in any of the engine parts because of vibration and without

imparting excessive vibration forces to the aircraft structure.

(b) Each engine design must undergo a vibration survey to establish that the vibration characteristics of those components that may be subject to induced vibration are acceptable throughout the approved flight envelope and engine operating range for the specific installation configuration. The possible sources of the induced vibration that the survey must assess are mechanical, aerodynamic, acoustical, internally induced electromagnetic, installation induced effects that can affect the engine vibration characteristics, and likely environmental effects. This survey must be shown by test, validated analysis, or a combination thereof.

JS4.2721 Overtorque

When approval is sought for a transient maximum engine overtorque, the applicant must demonstrate by test, validated analysis, or a combination thereof, that the engine can continue operation after operating at the maximum engine overtorque condition without maintenance action. Upon conclusion of overtorque tests conducted to show compliance with this subpart, or any other tests that are conducted in combination with the overtorque test, each engine part or individual groups of components must meet the requirements of JS4.2729.

JS4.2722 Calibration Assurance

Each engine must be subjected to calibration tests to establish its power characteristics and the conditions both before and after the endurance and durability demonstrations specified in JS4.2723 and JS4.2726.

JS4.2723 Endurance Demonstration

(a) The applicant must subject the engine to an endurance demonstration, acceptable to the Administrator, to demonstrate the engine's limit capabilities.

(b) The endurance demonstration must include increases and decreases of the engine's power settings, energy regeneration, and dwellings at the power settings or energy regeneration for sufficient durations that produce the extreme physical conditions the engine experiences at rated performance levels, operational limits, and at any other conditions or power settings that are required to verify the limit capabilities of the engine.

JS4.2724 Temperature Limit

The engine design must demonstrate its capability to endure operation at its temperature limits plus an acceptable

margin. The applicant must quantify and justify the margin to the Administrator. The demonstration must be repeated for all declared duty cycles and ratings, and operating environments, that would impact temperature limits.

JS4.2725 Operation Demonstration

The engine design must demonstrate safe operating characteristics, including but not limited to power cycling, starting, acceleration, and overspeeding throughout its declared flight envelope and operating range. The declared engine operational characteristics must account for installation loads and effects.

JS4.2726 Durability Demonstration

The engine must be subjected to a durability demonstration to show that each part of the engine has been designed and constructed to minimize any unsafe condition of the system between overhaul periods or between engine replacement intervals if the overhaul is not defined. This test must simulate the conditions in which the engine is expected to operate in service, including typical start-stop cycles, to establish when the initial maintenance is required.

JS4.2727 System and Component Tests

The applicant must show that systems and components that cannot be adequately substantiated in accordance with the endurance demonstration or other demonstrations will perform their intended functions in all declared environmental and operating conditions.

JS4.2728 Rotor Locking Demonstration

If shaft rotation is prevented by locking the rotor(s), the engine must demonstrate:

- (a) Reliable rotor locking performance;
- (b) Reliable unlocking performance; and
- (c) That no hazardous engine effects, as specified in JS4.2717(d)(2), will occur.

JS4.2729 Teardown Inspection

- (a) Teardown evaluation.
 - (1) After the endurance and durability demonstrations have been completed, the engine must be completely disassembled. Each engine component and lubricant must be eligible for continued operation in accordance with the information submitted for showing compliance with JS4.1529.
 - (2) Each engine component having an adjustment setting and a functioning

characteristic that can be established independent of installation on or in the engine must retain each setting and functioning characteristic within the established and recorded limits at the beginning of the endurance and durability demonstrations.

(b) Non-Teardown evaluation.

If a teardown cannot be performed for all engine components in a non-destructive manner, then the inspection or replacement intervals for these components and lubricants must be established based on the endurance and durability demonstrations and documented in the ICA in accordance with JS4.1529.

JS4.2730 Containment

The engine must be designed and constructed to protect against likely hazards from rotating components as follows—

(a) The design of the case surrounding rotating components must provide for the containment of the rotating components in the event of failure, unless the applicant shows that the margin to rotor burst precludes the possibility of a rotor burst.

(b) If the margin to burst shows the case must have containment features in the event of failure, the case must provide for the containment of the failed rotating components. The applicant must define by test, validated analysis, or a combination thereof, and document in the engine installation manual, the energy level, trajectory, and size of fragments released from damage caused by the main rotor failure, and that pass forward or aft of the surrounding case.

JS4.2731 Operation With a Variable-Pitch Propeller

The applicant must conduct functional demonstrations including feathering, negative torque, negative thrust, and reverse thrust operations, as applicable, with a representative propeller. These demonstrations may be conducted in a manner acceptable to the Administrator as part of the endurance, durability, and operation demonstrations.

JS4.2732 General Conduct of Tests

(a) Maintenance of the engine may be made during the tests in accordance with the service and maintenance instructions submitted in compliance with JS4.1529, ICA.

(b) The applicant must subject the engine or its parts to maintenance and additional tests that the Administrator finds necessary if—

- (1) The frequency of the service is excessive;

(2) The number of stops due to engine malfunction is excessive;

(3) Major repairs are needed; or

(4) Replacement of a part is found necessary during the tests or due to the teardown inspection findings.

(c) Upon completion of all demonstrations and testing specified in these airworthiness criteria, the engine and its components must be—

(1) Within serviceable limits;

(2) Safe for continued operation; and

(3) Capable of operating at declared ratings while remaining within limits.

JS4.2733 Engine Electrical Systems

(a) Applicability.

Any system or device that provides, uses, conditions, or distributes electrical power, and is part of the engine type design, must provide for the continued airworthiness of the engine and maintain electric engine ratings.

(b) Electrical systems.

The electrical system must ensure the safe generation and transmission of power, electrical load shedding, and that the engine does not experience any unacceptable operating characteristics or exceed its operating limits.

(c) Electrical-power distribution.

(1) The engine electrical-power distribution system must be designed to provide the safe transfer of electrical energy throughout the electrical power plant. The system must be designed to provide electrical power so that the loss, malfunction, or interruption of the electrical power source will not result in a hazardous engine effect, as defined in JS4.2717(d)(2).

(2) The system must be designed and maintained to withstand normal and abnormal conditions during all ground and flight operations.

(3) The system must provide mechanical or automatic means to mitigate a faulted electrical-energy generation or storage device from leading to hazardous engine effects, as defined in JS4.2717(d)(2), or detrimental effects in the intended aircraft application.

(d) Protection systems.

The engine electrical system must be designed such that the loss, malfunction, interruption of the electrical power source, or power conditions that exceed design limits will not result in hazardous engine effects, as defined in JS4.2717(d)(2), or detrimental effects in the intended aircraft application.

(e) Electrical Power Characteristics.

The applicant must identify and declare, in the engine installation manual, the characteristics of any electrical power—

- (1) Supplied from the aircraft to the engine electrical system, for starting and

operating the engine, including transient and steady-state voltage limits, or

(2) Supplied from the engine to the aircraft via energy regeneration, and any other characteristics necessary for safe operation of the engine.

(f) Environmental limits.

Environmental limits that cannot be adequately substantiated by endurance demonstration, validated analysis, or a combination thereof must be demonstrated by the system and component tests in JS4.2727.

(g) Electrical-system failures.

The engine electrical system must—

(1) Have a maximum rate of Loss of Power Control (LOPC) that is suitable for the intended aircraft application;

(2) When in the full-up configuration, be single fault tolerant, as determined by the Administrator, for electrical, electrically detectable, and electronic failures involving LOPC events;

(3) Not have any single failure that results in hazardous engine effects as defined in JS4.2717(d)(2); and

(4) Not have any likely failure or malfunction that leads to local events in the intended aircraft application.

(h) System safety assessment.

The applicant must perform a system safety assessment. This assessment must identify faults or failures that affect normal operation, together with the predicted frequency of occurrence of these faults or failures. The intended aircraft application must be taken into account to assure the assessment of the engine system safety is valid.

Subpart I—Propeller Requirements

JS4.2805 Propeller Ratings and Operating Limitations

Propeller ratings and operating limitations must be established by the applicant and approved by the Administrator, including ratings and limitations based on the operating conditions and information specified in this subpart, as applicable, and any other information found necessary for safe operation of the propeller.

§ 35.7 Features and Characteristics

(a) through (b) [Applicable to Model JAS4-1]

JS4.2815 Safety Analysis

(a) The applicant must:

(1) Analyze the propeller system to assess the likely consequences of all failures that can reasonably be expected to occur. This analysis will take into account, if applicable:

(i) The propeller system when installed on the aircraft. When the analysis depends on representative components, assumed interfaces, or

assumed installed conditions, the assumptions must be stated in the analysis.

(ii) Consequential secondary failures and dormant failures.

(iii) Multiple failures referred to in paragraph (d) of this section, or that result in the hazardous propeller effects defined in paragraph (g)(1) of this section.

(2) Summarize those failures that could result in major propeller effects or hazardous propeller effects defined in paragraph (g) of this section, and estimate the probability of occurrence of those effects.

(3) Show that hazardous propeller effects are not predicted to occur at a rate in excess of that defined as extremely remote (probability of 10^{-7} or less per propeller flight hour). Because the estimated probability for individual failures may be insufficiently precise to enable the applicant to assess the total rate for hazardous propeller effects, compliance may be shown by demonstrating that the probability of a hazardous propeller effect arising from an individual failure can be predicted to be not greater than 10^{-8} per propeller flight hour. In dealing with probabilities of this low order of magnitude, absolute proof is not possible, and reliance must be placed on engineering judgment and previous experience, combined with sound design and test philosophies.

(b) If significant doubt exists as to the effects of failures or likely combination of failures, the Administrator may require assumptions used in the analysis to be verified by test.

(c) The primary failures of certain single propeller elements (for example, blades) cannot be sensibly estimated in numerical terms. If the failure of such elements is likely to result in hazardous propeller effects, those elements must be identified as propeller critical parts. For propeller critical parts, the applicant must meet the prescribed integrity specifications of JS4.2816. These instances must be stated in the safety analysis.

(d) If reliance is placed on a safety system to prevent a failure progressing to hazardous propeller effects, the possibility of a safety system failure, in combination with a basic propeller failure, must be included in the analysis. Such a safety system may include safety devices, instrumentation, early warning devices, maintenance checks, and other similar equipment or procedures.

(e) If the safety analysis depends on one or more of the following items, those items must be identified in the analysis and appropriately substantiated.

(1) Maintenance actions being carried out at stated intervals. This includes verifying that items that could fail in a latent manner are functioning properly. When necessary to prevent hazardous propeller effects, these maintenance actions and intervals must be published in the ICA required under JS4.1529. Additionally, if errors in maintenance of the propeller system could lead to hazardous propeller effects, the appropriate maintenance procedures must be included in the relevant propeller manuals.

(2) Verification of the satisfactory functioning of safety or other devices at pre-flight or other stated periods. The details of this satisfactory functioning must be published in the appropriate manual.

(3) The provision of specific instrumentation not otherwise required. Such instrumentation must be published in the appropriate documentation.

(4) A fatigue assessment.

(f) If applicable, the safety analysis must include, but not be limited to, assessment of indicating equipment, manual and automatic controls, governors and propeller-control systems, synchrophasers, synchronizers, and propeller thrust reversal systems.

(g) Unless otherwise approved by the Administrator and stated in the safety analysis, the following failure definitions apply to compliance with these airworthiness criteria.

(1) The following are regarded as hazardous propeller effects:

(i) The development of excessive drag.

(ii) A significant thrust in the opposite direction to that commanded by the pilot.

(iii) The release of the propeller or any major portion of the propeller.

(iv) A failure that results in excessive unbalance.

(2) The following are regarded as major propeller effects for variable-pitch propellers:

(i) An inability to feather the propeller for feathering propellers.

(ii) An inability to change propeller pitch when commanded.

(iii) A significant uncommanded change in pitch.

(iv) A significant uncontrollable torque or speed fluctuation.

JS4.2816 Propeller Critical Parts

The integrity of each propeller critical part identified by the safety analysis required by JS4.2815 must be established by:

(a) A defined engineering process for ensuring the integrity of the propeller critical part throughout its service life,

(b) A defined manufacturing process that identifies the requirements to

consistently produce the propeller critical part as required by the engineering process, and

(c) A defined service-management process that identifies the continued airworthiness requirements of the propeller critical part as required by the engineering process.

§ 35.17 Materials and Manufacturing Methods

(a) through (c) [Applicable to Model JAS4–1]

§ 35.19 Durability

[Applicable to Model JAS4–1]

JS4.2821 Variable- and Reversible-Pitch Propellers

(a) No single failure or malfunction in the propeller system will result in unintended travel of the propeller blades to a position below the in-flight low-pitch position. The extent of any intended travel below the in-flight low-pitch position must be documented by the applicant in the appropriate manuals. Failure of structural elements need not be considered if the occurrence of such a failure is shown to be extremely remote under JS4.2815.

(b) For propellers incorporating a method to select blade pitch below the in-flight low-pitch position, provisions must be made to sense and indicate to the flightcrew that the propeller blades are below that position by an amount defined in the installation instructions. The method for sensing and indicating the propeller blade pitch position must be such that its failure does not affect the control of the propeller.

§ 35.22 Feathering Propellers

(a) through (c) [Applicable to Model JAS4–1]

JS4.2823 Propeller Control System

The requirements of this section apply to any system or component that controls, limits, or monitors propeller functions.

(a) The propeller control system must be designed, constructed and validated to show that:

(1) The propeller control system, operating in normal and alternative operating modes and in transition between operating modes, performs the functions defined by the applicant throughout the declared operating conditions and approved flight envelope.

(2) The propeller control system functionality is not adversely affected by the declared environmental conditions, including temperature, electromagnetic interference (EMI), high intensity radiated fields (HIRF), and

lightning. The environmental limits to which the system has been satisfactorily validated must be documented in the appropriate propeller manuals.

(3) A method is provided to indicate that an operating mode change has occurred if flightcrew action is required. In such an event, operating instructions must be provided in the appropriate manuals.

(b) The propeller control system must be designed and constructed so that, in addition to compliance with JS4.2815:

(1) No single failure results in a hazardous propeller effect;

(2) Local events in the intended aircraft installation will not result in hazardous propeller effects;

(3) The loss of normal propeller pitch control does not cause a hazardous propeller effect under the intended operating conditions; and

(4) The failure or corruption of data or signals shared across propellers does not cause a hazardous propeller effect.

(c) Electronic propeller-control-system embedded software must be designed and implemented by a method approved by the Administrator that is consistent with the criticality of the performed functions and that minimizes the existence of software errors.

(d) The propeller control system must be designed and constructed so that the failure or corruption of aircraft-supplied data does not result in hazardous propeller effects.

(e) The propeller control system must be designed and constructed so that the loss, interruption, or abnormal characteristic of aircraft-supplied electrical power does not result in hazardous propeller effects. The power quality requirements must be described in the appropriate manuals.

§ 35.24 Strength

[Applicable to Model JAS4–1]

§ 35.33 General

(a) through (c) [Applicable to Model JAS4–1]

§ 35.34 Inspections, Adjustments, and Repairs

(a) through (b) [Applicable to Model JAS4–1]

§ 35.35 Centrifugal Load Tests

(a) through (c) [Applicable to Model JAS4–1]

§ 35.36 Bird Impact

[Applicable to Model JAS4–1]

§ 35.37 Fatigue Limits and Evaluation

(a) through (c)(1) [Applicable to Model JAS4–1, except replace the reference to § 35.15 with JS4.2815, and

the reference to “§ 23.2400(c) or § 25.907” with JS4.2400(c)]

(c)(2) [Not applicable to Model JAS4–1]

§ 35.38 Lightning Strike

[Applicable to Model JAS4–1]

§ 35.39 Endurance Test

(a) through (c) [Applicable to Model JAS4–1, except replace the reference to “part 33” with “these airworthiness criteria”]

JS4.2840 Functional Test

The variable-pitch propeller system must be subjected to the applicable functional tests of this section. The same propeller system used in the endurance test of § 35.39 must be used in the functional tests and must be driven by a representative engine on a test stand or on the aircraft. The propeller must complete these tests without evidence of failure or malfunction. This test may be combined with the endurance test for accumulation of cycles.

(a) Governing and reversible-pitch propellers. Fifteen hundred complete cycles must be made across the range of forward pitch and rotational speed. In addition, 200 complete cycles of control must be made from lowest normal pitch to maximum reverse pitch. During each cycle, the propeller must run for 30 seconds at the maximum power and rotational speed selected by the applicant for maximum reverse pitch.

(b) Feathering propellers. Fifty cycles of feather and unfeather operation must be made.

(c) An analysis based on tests of propellers of similar design may be used in place of the tests of this section.

§ 35.41 Overspeed and Overtorque

(a) through (b) [Applicable to Model JAS4–1]

§ 35.42 Components of the Propeller Control System

[Applicable to Model JAS4–1]

Appendix A to Part 23—Instructions for Continued Airworthiness

A23.1 through A23.3(g) and A23.4

[Applicable to Model JAS4–1]

A23.3(h) [Not applicable to Model JAS4–1]

Appendix A1—Instructions for Continued Airworthiness (Electric Engine)

AJS4.2701 General

(a) This appendix specifies requirements for the preparation of ICA for the engines as required by JS4.1529.

(b) The ICA for the engine must include the ICA for all engine parts.

(c) The applicant must submit to the FAA a program to show how the applicant's changes to the ICA will be distributed, if applicable.

A33.2 Format

(a) through (b) [Applicable to Model JAS4-1]

A33.3 Content

(a) and (b) [Applicable to Model JAS4-1]
(c) [Not applicable to Model JAS4-1]

A33.4 Airworthiness Limitations Section

(a) [Applicable to Model JAS4-1]
(b) [Not applicable to Model JAS4-1]

Appendix A2—Instructions for Continued Airworthiness (Propellers)**AJS4.2801 General**

(a) This appendix specifies requirements for the preparation of ICA for the propellers as required by JS4.1529.

(b) The ICA for the propeller must include the ICA for all propeller parts.

(c) The applicant must submit to the FAA a program to show how changes to the ICA made by the applicant or by the manufacturers of propeller parts will be distributed, if applicable.

A35.2 Format

(a) through (b) [Applicable to Model JAS4-1]

A35.3 Content

(a) through (b) [Applicable to Model JAS4-1]

A35.4 Airworthiness Limitations Section

[Applicable to Model JAS4-1]

Issued in Des Moines, WA, on February 29, 2024.

James E. Wilborn,

Acting Manager, Certification Engagement Branch, Policy and Standards Division, Aircraft Certification Service.

[FR Doc. 2024-04690 Filed 3-7-24; 8:45 am]

BILLING CODE 4910-13-P

Reader Aids

Federal Register

Vol. 89, No. 47

Friday, March 8, 2024

CUSTOMER SERVICE AND INFORMATION

Federal Register/Code of Federal Regulations	
General Information, indexes and other finding aids	202-741-6000
Laws	741-6000
Presidential Documents	
Executive orders and proclamations	741-6000
The United States Government Manual	741-6000
Other Services	
Electronic and on-line services (voice)	741-6020
Privacy Act Compilation	741-6050

ELECTRONIC RESEARCH

World Wide Web

Full text of the daily Federal Register, CFR and other publications is located at: www.govinfo.gov.

Federal Register information and research tools, including Public Inspection List and electronic text are located at: www.federalregister.gov.

E-mail

FEDREGTOC (Daily Federal Register Table of Contents Electronic Mailing List) is an open e-mail service that provides subscribers with a digital form of the Federal Register Table of Contents. The digital form of the Federal Register Table of Contents includes HTML and PDF links to the full text of each document.

To join or leave, go to <https://public.govdelivery.com/accounts/USGPOOFR/subscriber/new>, enter your email address, then follow the instructions to join, leave, or manage your subscription.

PENS (Public Law Electronic Notification Service) is an e-mail service that notifies subscribers of recently enacted laws.

To subscribe, go to <http://listserv.gsa.gov/archives/publaws-l.html> and select *Join or leave the list (or change settings)*; then follow the instructions.

FEDREGTOC and **PENS** are mailing lists only. We cannot respond to specific inquiries.

Reference questions. Send questions and comments about the Federal Register system to: fedreg.info@nara.gov

The Federal Register staff cannot interpret specific documents or regulations.

FEDERAL REGISTER PAGES AND DATE, MARCH

15011-15430.....	1
15431-15724.....	4
15725-15948.....	5
15949-16442.....	6
16443-16682.....	7
16683-17264.....	8

CFR PARTS AFFECTED DURING MARCH

At the end of each month the Office of the Federal Register publishes separately a List of CFR Sections Affected (LSA), which lists parts and sections affected by documents published since the revision date of each title.

2 CFR		Proposed Rules:	
3474.....	15671	21.....	16709
Proposed Rules:		33.....	16474
Ch. XVI.....	16701	39.....	15517, 15965, 16486, 16489, 16710
		71.....	15065
3 CFR		15 CFR	
Proclamations:		Proposed Rules:	
10703.....	15933	7.....	15066
10704.....	15935	922.....	15272
10705.....	15937	16 CFR	
10706.....	15939	461.....	15017
10707.....	15949	Proposed Rules:	
10708.....	15953	461.....	15072
Executive Orders:		17 CFR	
13288 (revoked by EO 14118).....	15945	Proposed Rules:	
13391 (revoked by EO 14118).....	15945	1.....	15312
13469 (revoked by EO 14118).....	15945	22.....	15312
13873 (Amended by EO 14117).....	15421	30.....	15312
14034 (Amended by EO 14117).....	15421	39.....	15312
14117.....	15421	48.....	15083
14118.....	15945	18 CFR	
Administrative Orders:		157.....	16683
Notices		19 CFR	
Notice of March 4, 2024.....	15947	24.....	15958
Notice of March 5, 2024.....	16443	21 CFR	
6 CFR		14.....	15959
19.....	15671	Proposed Rules:	
7 CFR		50.....	15094
16.....	15671	22 CFR	
982.....	15955	205.....	15671
Proposed Rules:		24 CFR	
966.....	16471	5.....	15671
9 CFR		26 CFR	
201.....	16092	Proposed Rules:	
1.....	15523	28 CFR	
10 CFR		38.....	15671
Proposed Rules:		Proposed Rules:	
37.....	16701	202.....	15780
13 CFR		29 CFR	
127.....	16445	2.....	15671
14 CFR		31 CFR	
21.....	17230	344.....	15440
39.....	15431, 15725, 15728, 15733	501.....	15740
71.....	15011, 15014, 15015, 15434, 15435, 15736, 15738, 16446, 16447, 16448, 16449	510.....	15740
73.....	15016	535.....	15740
97.....	15437, 15439	536.....	15740
		546.....	15744
		547.....	15740

548.....15740
 551.....15740
 552.....15740
 553.....15740
 558.....15740
 561.....15740
 566.....15740
 570.....15740
 578.....15740
 587.....16450
 588.....15740, 16452
 589.....15740
 590.....15740
 591.....16452
 592.....15740
 594.....15740
 597.....15740
 598.....15740

33 CFR

100.....16685
 117.....16688, 16690
 165.....16453, 16455, 16693,
 16695
 401.....15959

34 CFR

75.....15671
 76.....15671

Proposed Rules:
 Ch. III.....15525

36 CFR

1202.....16697

37 CFR

Proposed Rules:
 42.....15531

38 CFR

0.....15450
 3.....15753
 17.....15451
 50.....15671
 61.....15671
 62.....15671

Proposed Rules:
 36.....16491

39 CFR

20.....15474
 111.....15474

40 CFR

50.....15962
 52.....15031, 15035, 16202,
 16460, 16698
 53.....16202

58.....16202
 60.....16820
 62.....15038
 63.....16408
 180.....15040, 15046
 300.....16463

Proposed Rules:
 52.....15096, 15098, 16496,
 16712
 63.....15101
 180.....16714
 260.....15967
 261.....15967
 270.....15967
 300.....16498

42 CFR

493.....15755

45 CFR

87.....15671
 98.....15366
 170.....16469
 171.....16469
 305.....15475

47 CFR

64.....15061, 15480, 15756
 73.....15480, 15481

Proposed Rules:
 11.....16504
 15.....15540
 64.....15802

48 CFR

22.....15763
 25.....15763
 52.....15763

49 CFR

107.....15636
 171.....15636
 172.....15636
 173.....15636
 178.....15636
 180.....15636

50 CFR

17.....15763, 16624
 648.....15482, 15484
 665.....15062
 679.....15484

Proposed Rules:
 29.....15806
 680.....16510

LIST OF PUBLIC LAWS

Note: No public bills which have become law were received by the Office of the Federal Register for inclusion

in today's **List of Public Laws**.

Last List March 4, 2024

Public Laws Electronic Notification Service (PENS)

PENS is a free email notification service of newly

enacted public laws. To subscribe, go to https://portalguard.gsa.gov/_layouts/PG/register.aspx.

Note: This service is strictly for email notification of new laws. The text of laws is not available through this service. **PENS** cannot respond to specific inquiries sent to this address.