

CONSUMER PRODUCT SAFETY COMMISSION

16 CFR Parts 1112, 1130, and 1242

[CPSC Docket No. 2023–0037]

Safety Standard for Nursing Pillows

AGENCY: Consumer Product Safety Commission.

ACTION: Final rule.

SUMMARY: Pursuant to the Danny Keysar Child Product Safety Notification Act, section 104 of the Consumer Product Safety Improvement Act of 2008 (CPSIA), the U.S. Consumer Product Safety Commission (Commission or CPSC) is issuing this final rule establishing a consumer product safety standard for nursing pillows. CPSC is also amending its regulations regarding third party conformity assessment bodies, to include the safety standard for nursing pillows in the list of notices of requirements (NORs), along with identifying nursing pillows as a durable infant or toddler product subject to consumer registration requirements.

DATES: This rule will become effective April 23, 2025. The incorporation by reference of certain material listed in this rule is approved by the Director of the Federal Register as of April 23, 2025.

FOR FURTHER INFORMATION CONTACT: Will Cusey, Small Business Ombudsman, U.S. Consumer Product Safety Commission, 4330 East-West Highway, Bethesda, MD 20814; email: sbo@cpsc.gov; telephone: (301) 504–7945 or (888) 531–9070.

SUPPLEMENTARY INFORMATION:

I. Background and Statutory Authority

A. Background

Although nursing pillows are primarily intended to support an infant during breast or bottle feeding, they are sometimes used to support infants for sleep or lounging. These sleep and lounging uses have led to infant deaths and serious injuries from suffocation, entrapment, or falls.

In 1992, under the Federal Hazardous Substances Act (FHSA), CPSC adopted a ban on certain types of hazardous “infant pillows” that contain loosely filled granular materials that conform to an infant’s face or body. This ban is codified at 16 CFR 1500.18(a)(16) (Infant Pillow Ban). 57 FR 27912 (June 23, 1992). Certain nursing pillows are exempt from the Infant Pillow Ban, while others, such as pillows with a non-granular fill, do not fall within its scope. 16 CFR 1500.86(a)(9). Many products are currently marketed for both nursing and “lounging,” despite the

suffocation hazard posed by propping up very young infants with these products.

On September 26, 2023, the Commission issued a notice of proposed rulemaking (NPR) under section 104 of the CPSIA that proposed a mandatory consumer product safety standard for nursing pillows, to address risks of death and injury associated with these products. 88 FR 65865. The proposed safety standard for nursing pillows addressed the suffocation, entrapment, and fall hazards associated with infants in nursing pillows by including performance requirements, labeling and instructional literature requirements, and a prohibition on the use of infant restraints.

On April 23, 2024, CPSC published a notice of availability (NOA) with a 30-day comment period that closed on May 23, 2024. 89 FR 30294. The NOA announced the availability of, and sought comments from the public on, the incident data relied upon for the NPR. The NOA also sought public comments on how the final rule for nursing pillows should address removable nursing pillow covers, or slipcovers.

On September 10, 2024, after the NPR was published, ASTM International (ASTM) published a voluntary standard, ASTM F3669–24, *Standard Consumer Safety Specification for Nursing Pillows*. A detailed discussion of the voluntary standard can be found in section IV of this preamble. The Commission is finalizing this rule to establish mandatory performance and labeling requirements for nursing pillows based on the proposal in the NPR, public comments on both the NPR and the NOA, and staff’s assessment of the recent ASTM voluntary standard for nursing pillows, discussed below in sections VI and VII.

In particular, while a number of provisions of ASTM’s voluntary standard are substantially similar to provisions of the NPR and the final rule, the Commission determines that more stringent standards set forth in the final rule would further reduce the risk of injury associated with these products.¹

¹ On September 18, 2024, the Commission voted (5–0) to publish this final rule as drafted. Chair Hoehn-Saric and Commissioners Trumka and Boyle issued statements in connection with their vote, available at: <https://www.cpsc.gov/About-CPSC/Chairman-Alexander-Hoehn-Saric/Statement/Statement-of-Chair-Alexander-Hoehn-Saric-on-Commission-Approval-of-a-Final-Rule-Establishing-a-Safety-Standard-for-Nursing-Pillows>; <https://www.cpsc.gov/About-CPSC/Commissioner/Richard-Trumka/Statement/Commissioner-Trumka-Safety-Changes-for-Nursing-Pillows-Will-Save-Babies%E2%80%99-Lives>; and <https://www.cpsc.gov/About-CPSC/Commissioner/Mary-T-Boyle/Statement/Commissioner-Mary-T-Boyle-Statement-on-Vote-to-Issue-Final-Rule-on-Nursing-Pillows>.

B. Statutory Authority

Section 104(b) of the CPSIA, part of the Danny Keysar Child Product Safety Notification Act, requires the Commission to (1) examine and assess the effectiveness of voluntary consumer product safety standards for durable infant or toddler products, in consultation with representatives of consumer groups, juvenile product manufacturers, and independent child product engineers and experts; and (2) promulgate consumer product safety standards for durable infant and toddler products. 15 U.S.C. 2056a(b)(1). Standards issued under section 104 are to be “substantially the same as” the applicable voluntary standards, or more stringent than the voluntary standard, if the Commission determines that more stringent requirements would further reduce the risk of injury associated with the product. *Id.* at 2056a(b)(1)(B).

The Commission has examined and assessed the effectiveness of the ASTM voluntary consumer product safety standard for nursing pillows, ASTM F3669–24, *Standard Consumer Safety Specification for Nursing Pillows*. Regarding the consultation requirement in section 104(b)(1) of the CPSIA, CPSC staff regularly participates in the juvenile products subcommittee meetings of ASTM International (ASTM). ASTM subcommittees consist of members who represent producers, users, consumers, government, and academia.² CPSC began the consultation process for this rulemaking in December 2021, via a letter from CPSC staff requesting that ASTM form a working group to develop a voluntary standard to reduce the risk of death and injury from hazards associated with infant pillow products, including nursing pillows.³ CPSC staff provided ASTM with incident data associated with both nursing pillows and infant support cushions. In response, ASTM formed the following subcommittees to develop two separate voluntary standards:

- F15.16 Nursing Pillows subcommittee,⁴ intended to develop a standard for nursing pillows; and
- F15.21 Infant Loungers subcommittee, with a remit including

² ASTM International website: www.astm.org, About ASTM International.

³ <https://www.cpsc.gov/s3fs-public/Nursing-and-Support-Pillow-VS-request.pdf>.

⁴ Since the subcommittee’s formation, the name of the subcommittee has evolved and gone through the following variants: Feeding and Infant Support Products subcommittee, Infant Feeding Support Products subcommittee, and Infant Feeding Supports subcommittee.

nursing pillows that are also intended for lounging.

CPSC staff actively participated in the ASTM's F15.16 Nursing Pillows subcommittee to develop ASTM F3669—24 with requirements that address the hazards associated with these products.⁵

Consistent with CPSC staff's assessment of the voluntary standard, the Commission determines that the more stringent requirements included in this final rule would further reduce the risk of injury associated with nursing pillows. In part, the mandatory consumer product safety standard for nursing pillows is "substantially the same as" ASTM F3669—24 because it includes similar performance and labeling/instructional material requirements. However, portions of the CPSC mandatory standard are more stringent than the ASTM voluntary standard, as these requirements would further reduce the risk of injury associated with the use of nursing pillows. For example, the definition of a "nursing pillow" in the final rule states that these products include removable covers, or slipcovers, that are sold on or together with the nursing pillow. The ASTM standard does not contain any safety requirements for the cover element of nursing pillows. In addition, the product warning in the final rule includes a statement to instruct consumers to move the baby to an infant sleep product if the baby falls asleep or if the caregiver feels drowsy. This scenario is associated with three infant fatalities known to CPSC. Yet the warnings specified in the ASTM standard do not specifically address it. Section 104(d) of the CPSIA requires manufacturers of durable infant or toddler products to establish a product registration program and comply with CPSC's implementing rule, 16 CFR part 1130. Any product defined as a "durable infant or toddler product" in part 1130 must comply with the product registration requirements, as well as testing and certification requirements for children's products, as codified in 16 CFR parts 1107 and 1109. Section 104(f)(1) of the CPSIA defines a "durable infant or toddler product" as a "durable product intended for use, or that may be reasonably expected to be used, by children under the age of 5 years." 15 U.S.C. 2056a(f)(1). Section 104(f)(2) of the CPSIA includes a non-exhaustive list of categories of products

that are durable infant or toddler products, including products used for feeding support, such as high chairs, booster chairs, and hook-on chairs. *Id.* 2056a(f)(2)(C); *See Requirements for Consumer Registration of Durable Infant or Toddler Products*, 74 FR. 68668–68669 (Dec. 29, 2009).

This final rule amends part 1130 to include "nursing pillow" as a durable infant or toddler product, as proposed in the NPR, because they are: (1) intended for use, and may be reasonably expected to be used, by children under the age of 5 years; (2) similar to other feeding support products listed in section 104(f)(2) of the CPSIA, such as high chairs, booster chairs, and hook-on chairs; and (3) commonly available for resale or "handed down" for use by other children over a period of years.

Lastly, products subject to a consumer product safety rule under the Consumer Product Safety Act (CPSA) must be certified as complying with all applicable CPSC-enforced requirements, based on testing conducted by a CPSC-accepted third party conformity assessment body. 15 U.S.C. 2063(a). The Commission must publish an NOR for the accreditation of third party conformity assessment bodies to assess conformity with a children's product safety rule to which a children's product is subject. *Id.* 2063(a)(3). Accordingly, we now finalize an amendment to part 1112, as proposed in the NPR, to add the new *Safety Standard for Nursing Pillows*, 16 CFR part 1242, to the list of NORs for children's product safety rules. The amendment allows test laboratories applying for CPSC acceptance to seek accreditation to test nursing pillows within the scope of the rule.

C. NPR

The scope of the NPR included all "nursing pillows," defined as any product intended, marketed, or designed to position and support an infant close to a caregiver's body while breastfeeding or bottle feeding. These products rest upon, wrap around, or are worn by a caregiver in a seated or reclined position. The NPR proposed exemptions for (1) maternity pillows, as defined in 16 CFR 1242.2, because they are not intended primarily for nursing and are intended to support the body of a pregnant adult, and (2) sling carriers, as defined in 16 CFR part 1228, because they are subject to the *Safety Standard for Sling Carriers*. 16 CFR part 1228.

The proposed nursing pillow safety standard included performance requirements and labeling and instructional literature requirements to address the following hazards

associated with an infant's use of a nursing pillow:

(1) suffocation hazards from the product conforming to an infant's face and occluding the infant's airways;

(2) entrapment hazards posed when the product restricts an infant's head movements;

(3) suffocation and fall risks resulting from the presence of infant restraints that could suggest that infants can safely be left unattended in the product; and

(4) suffocation, entrapment, or fall risks when an infant is left unattended in the product.

In the NPR, the Commission also proposed to amend the consumer registration rule, 16 CFR part 1130, to identify "nursing pillows" as a category of "durable infant or toddler products" subject to the consumer registration rule and testing and certification as a children's product. Finally, the Commission proposed to amend its regulation at 16 CFR part 1112 to add "nursing pillows" to the list of products that require third party testing as a basis for certification.

D. Overview of the Final Rule

Pursuant to section 104 of the CPSIA, the Commission is issuing a mandatory standard for nursing pillows. 15 U.S.C. 2056a. However, based on comments on the NPR and staff's assessment of the draft and published ASTM voluntary standard for nursing pillows in section IV, the final rule contains the following clarifications and changes from the NPR:

- The scope has been clarified to explain that slipcovers sold on or together with a nursing pillow are considered part of the nursing pillow, as defined in 16 CFR 1242.2, within the scope of the rule. Accordingly, the definition of "nursing pillow" has been amended to clarify that nursing pillows include any removable covers, or slipcovers, sold on or together with the product.

- Soft infant and toddler carriers, as defined in 16 CFR part 1226, have been added to the list of products outside the scope of the rule.

- The definition of "caregiver attachment" has been revised to clarify that a caregiver attachment is not an infant support surface.

- The definition of "conspicuous" has been revised to mean visible to the caregiver while placing the nursing pillow on or against the caregiver's body.

- The Small Parts requirement language has been revised to clarify that the cited small parts regulation does not specifically "define" a small part, but rather determines whether an item is a

⁵ The docket for this rulemaking on [Regulations.gov](https://www.regulations.gov) (CPSC-2023-0037) contains meeting logs for all CPSC staff-attended ASTM meetings related to the nursing pillow voluntary standard that occurred between issuance of the NPR and completing this final rule.

small part. The language for the Hazardous Sharp Edges or Points requirement has been clarified similarly.

- The Permanency of Labels and Warnings requirement has been corrected by changing a reference from “infant feeding supports” to “nursing pillows.”

- The figure illustrating the firmness test probe, Figure 1, has been revised for clarity.

- The Infant Support Surface Firmness test method has been revised to specify that, when selecting test locations, the edge of the test probe shall not extend beyond the edge of the nursing pillow. However, if the design or size of the product is such that the edge of the probe must extend beyond the product, then the probe must be centered over as much of the test surface as possible. The test method also has been revised to specify that the final force measurement at each location is taken only after the force has stabilized, meaning that it has not changed more than 0.1 Newtons (N) over 30 seconds.

- The Infant Containment test method has been reordered, so products with a caregiver attachment are tested first without the caregiver attachment secured, and then again with the caregiver attachment secured. This test method also revises references from “inner surfaces” of the nursing pillow to “inner wall,” for clarity, and revises the referenced figure, Figure 4, to clarify the test method and to show additional examples of passing and failing tests.

- The Caregiver Attachment Strength test method has been revised to clarify that the requirement applies to all fastening methods, not just buckles and clasps. The section name has also been corrected to add the term “Strength.”

- The figure showing the example product warning, Figure 7, has been revised to reflect changes in warning content in response to public comments. These changes include revising the initial sentence to state that “BABIES HAVE DIED USING NURSING PILLOWS FOR SLEEP OR LOUNGING,” stating explicitly that nursing pillows are for feeding only, revising and deleting some of the statements to reduce length, and adding a line or border to separate the sleep and suffocation-related warning content from the fall-related warning content.

Section VII of this preamble describes the final rule in more detail.

II. The Product Category

A. Scope of Products Within the Final Rule

The scope of the final rule includes all nursing pillows, as defined in 16

CFR 1242.2. Nursing pillows are infant products intended to position and support an infant during breastfeeding—also referred to as nursing—or bottle feeding. These products generally rest upon or are “worn” by the caregiver while seated or partially reclined.

Nursing pillows are most commonly C-, U-, or crescent- (or horseshoe-) shaped to fit closely around the caregiver’s torso. However, other designs exist, including a V- or boomerang-shaped product, a round pod with a recessed center to support the infant, a stack of multiple petal-shaped pillows attached to a central tubular pillow, and E-shaped products for twins. Most nursing pillows are filled with synthetic batting or foam, but products filled with cotton, wool, or dried grains are available.

The Commission considers removable nursing pillow covers, or slipcovers, that are sold on or together with the nursing pillow, to be a part of the nursing pillow and are therefore within the scope of the final rule. This comports with the broad definition of a “consumer product” in the CPSA as including any “component part” of a product. 15 U.S.C. 2052(a)(5). Slipcovers that are sold separately from a nursing pillow, not installed on the pillow or included in the price of the nursing pillow, are not within the scope of the final rule because they are not considered to be intended, marketed or designed as part of the product. Accordingly, the Commission is finalizing the definition of nursing pillow to include this clarification: “*Nursing pillow* means any product intended, marketed, or designed to position and support an infant close to a caregiver’s body while breastfeeding or bottle feeding, *including any removable covers, or slipcovers, sold on or together with such a product.* These products rest upon, wrap around, or are worn by a caregiver in a seated or reclined position.” (Emphasis added.) ASTM F3669 defines a nursing pillow using similar language about support while feeding but does not explicitly address slipcovers.

In addition to providing a support surface for infants, nursing pillows raise the infant to the desired height for feeding, thereby reducing muscular strain on the caregiver, and provide a buffering surface between the infant and the caregiver, reducing pressure on the caregiver’s abdomen. This latter function is especially helpful where the caregiver has abdominal stitches from a caesarean section. Some products include a strap or belt, sometimes with a buckle, to secure the product to the caregiver’s body (*i.e.*, a caregiver attachment), and a few have restraints

that attach the infant to the product. Many products come with removable fabric covers, and some products have small infant head support bolsters or fabric toys attached.⁶

B. Market Description

As discussed in the NPR, CPSC estimates that annual sales of new nursing pillows likely total approximately \$67 million. New nursing pillows range in price from \$15 to \$100, with most products in the \$25 to \$65 range. The more expensive models tend to have removable covers. The Commission’s estimate of \$67 million per year in sales of new nursing pillows assumes an average price of approximately \$50 and annual sales of 1.34 million units. The number of infants who feed with a nursing pillow is greater than this, however. Some parents may already own a pillow that was purchased for an older child, make a pillow, or buy a used pillow to use for nursing. Used nursing pillows and replacement covers for nursing pillows are commonly available from secondary marketplaces such as eBay and Mercari, where prices are observed to range from less than \$7 to more than \$120. The widespread availability of replacement covers extends the useful life and durability of nursing pillows, allowing covers to be cleaned or swapped for other colors, styles or designs.

Although more than a thousand businesses sell nursing pillows and nursing pillow covers online, just nine companies supply the models commonly sold in brick-and-mortar stores. Individual stores typically have fewer than four models of nursing pillows in stock, which limits consumers’ ability to assess the safety-related characteristics of the products and to make selections on that basis.

C. Infant Cushion/Pillow Ban and Nursing Pillow Exemption

Unlike the Infant Pillow Ban, this final rule sets a performance standard pursuant to the CPSIA that allows for the sale of nursing pillows that meet the requirements in the standard. As described below, this final rule is based in part on data concerning incidents that occurred between January 2010 through December 2022, many of which were fatal. The final rule does not alter either the Infant Pillow Ban at 16 CFR 1500.18(a)(16) or the exemption

⁶ See Staff Briefing Package: Staff’s Draft Proposed Rule for Nursing Pillows (Aug. 23, 2023) (Staff’s NPR Briefing Package) at 5, figures 1 and 2, for examples of nursing pillow designs, available at: <https://www.cpsc.gov/content/Commission-Briefing-Package-Notice-of-Proposed-Rulemaking-Safety-Standard-for-Nursing-Pillows>.

codified at 16 CFR 1500.86(a)(9), both of which remain in place. Thus, products that are not banned under the Infant Pillow Ban but that meet this rule's definition of a nursing pillow need to comply with the final rule.

III. Incident Data and Hazard Patterns

As described in the NPR, CPSC staff's search of the Consumer Product Safety Risk Management System (CPSRMS)⁷ and National Electronic Injury Surveillance System (NEISS)⁸ databases identified 154 fatal incidents and 88 nonfatal incidents and consumer concerns associated with nursing pillows, involving infants up to 12 months old, and reported to have occurred between January 1, 2010, and December 31, 2022. Accordingly, for the final rule, the Commission is aware of 242 incident reports associated with nursing pillows. Sixty-four percent of the incidents reported in the NPR involved a fatality.⁹ Nearly all (144 of the 154, or 94 percent) of the reported fatalities associated with nursing pillows involved infants 6 months old and younger, and most (110 out of 154, or 71 percent) were deaths of infants 3 months old or younger. Of the nonfatal incidents, 73 percent resulted in an injury and 27 percent reported no injury.¹⁰

A. Fatalities and Associated Hazard Patterns

The Commission is aware of 142 fatalities that involved use of the

⁷ CPSRMS is the epidemiological database that houses all anecdotal reports of incidents received by CPSC, "external cause"-based death certificates purchased by CPSC, all in-depth investigations of these anecdotal reports, as well as investigations of select NEISS injuries. CPSRMS documents include hotline reports, online reports, news reports, medical examiner's reports, death certificates, retailer/manufacture reports, and documents sent by state and local authorities, among others.

⁸ NEISS is a statistically valid surveillance system for collecting injury data. NEISS is based on a nationally representative probability sample of hospitals in the U.S. and its territories. Each participating NEISS hospital reports patient information for every emergency department visit associated with a consumer product or a poisoning to a child younger than five years of age. The total number of product-related hospital emergency department visits nationwide can be estimated from the sample of cases reported in the NEISS. See <https://www.cpsc.gov/Research--Statistics/NEISS-Injury-Data>.

⁹ More than half of the fatalities of which CPSC is aware were reported to have occurred since 2019. Staff's NPR Briefing Package at Tab A. However, staff noted that because the reported data are anecdotal, fluctuations in the numbers of reported incidents could simply reflect changes in reporting rather than an actual change in incident frequency. *Id.*

¹⁰ Among the reported incidents without injury, some included concerns such as product integrity or the smell of the nursing pillow that are unrelated to the hazards this proposed rule is intended to address.

nursing pillow for sleep; these cases often involved additional unsafe sleep conditions including sleep-surface sharing—also known as co-sleeping—or the presence of other soft bedding such as pillows or blankets. As described in the NPR, nursing pillows are intended to be used for feeding when both the infant and caregiver are awake, and the caregiver can ensure that the infant's airways are not covered by the pillow. However, consumers often placed infants on or in nursing pillows for sleep.

In addition, because infants frequently fall asleep during or after feeding and because nursing pillows appear to be comfortable sleeping environments and are small enough to fit within other sleep products such as a crib or bassinet, nursing pillows are foreseeably used for infant sleep, which creates a potential hazard for the infant. For example, if a sleeping infant rolls over so their face is pressed against the nursing pillow, the infant's airways may be blocked, causing suffocation. Similarly, if an infant falls into the opening where the caregiver is positioned during feeding, the infant can land face-down with the pillow surrounding their head, causing entrapment against the surface on which the pillow rests. Even if the infant remains with their back against the top of the nursing pillow, if the infant's position shifts so that their head falls against their chest or tilts backwards over the top of the pillow, the hyperextension or hyperflexion of the infant's neck can prevent breathing.

For the most part, no witnesses observed the fatal incidents, and 60 of the 154 fatal cases (39 percent) had insufficient details to enable CPSC staff to determine the hazard pattern or scenario. However, CPSC staff classified the remaining 94 reported fatalities by hazard patterns, based on the best available information about the position in which the victim was found. These positions include the following: face into product, face into other object/bedding outside product, face down in opening, neck extension/flexion, bedding over face, face into product or bedding (unknown),¹¹ entrapment/overlay while nursing, and overlay.

One hundred twenty-four fatalities (81 percent) involved the nursing pillow being used in or on a sleep product. Specifically, 62 fatalities (40 percent) involved the nursing pillow product being used in an infant sleep product,

¹¹ This hazard pattern includes cases where the infant was found with their face into either the nursing pillow or other bedding, but the specific product is unknown.

such as a crib, portable playpen, or bassinet; 61 fatalities (40 percent) involved use of the product on an adult bed or mattress; and one fatality involved a mattress of unknown size. Eighteen reported fatalities (12 percent) involved the product being used on a couch, sofa, or loveseat; one fatality involved the product being used on the caregiver's lap in a recliner chair; and the use location for 11 fatalities is unknown.

B. Nonfatal Incidents

CPSC is aware of 88 nonfatal incidents associated with nursing pillows in which 64 resulted in an injury to the infant and 24 did not lead to a reported injury. Of the 64 injury victims, 19 infants were known to have been treated and released from the emergency department, and all 19 involved the infant falling or rolling off, or out, of the nursing pillow. An additional three injuries, one involving a burn, one due to a fall, and one due to cardiopulmonary arrest after the infant was laying on the nursing pillow, resulted in hospital admission. The remaining 42 injuries, where the level of care was not known, included falls, near suffocation, near strangulation, choking, and skin irritation or allergy. In 66 percent (42 of 64) of the nonfatal injuries, the location was unknown, but the most common locations among the remaining incidents were couches and beds. The Commission is aware of following hazard patterns for the nursing pillow-related nonfatal incidents: skin allergy/irritation; fall/rollout from an elevated surface, from the same or unknown level, and while carrying the infant in the product; filling coming out/choking hazard; product integrity; and strong smell, among others.

IV. ASTM's Voluntary Standard for Nursing Pillows

On September 10, 2024, ASTM published a new voluntary standard for nursing pillows, ASTM F3669—24, *Standard Consumer Safety Specification for Nursing Pillows*. This section examines and assesses the ASTM standard.

A. Terminology

As noted in section II.A., the voluntary standard defines a nursing pillow similarly to the definition of "nursing pillow" in the final rule; however, the voluntary standard's definition does not include language clarifying that nursing pillows include slipcovers that are sold on or together with the product. By expressly including such slipcovers in the

definition, the final rule is more stringent than the ASTM standard and further reduces the risk of injury and death relative to the voluntary standard, as explained in section II.A.

The ASTM voluntary standard's definition of "caregiver attachment" is similar to the definition in the final rule but appears less protective by referring to the caregiver attachment as a "device or other mechanism," whereas the rule describes a "caregiver attachment" more broadly as a "portion of the product." Unlike the voluntary standard, the final rule also clarifies that portions of the product that function as an infant support surface are not considered caregiver attachments.

The ASTM voluntary standard defines "caregiver opening" differently than the final rule and adds a new definition for "inner wall," which is not included in the final rule. The voluntary standard's definition of inner wall implies that it includes any surface of the nursing pillow intended to fit against the caregiver's torso during use, even if that surface is part of a caregiver attachment. This contradicts the final rule's definition of "caregiver opening," which excludes caregiver attachments.

The voluntary standard defines "infant support surface" differently than the final rule. The ASTM standard differs functionally from the definition in the final rule by specifying that the infant support surface is necessarily horizontal. The Commission is aware of some nursing pillows where the infant support surface is not strictly horizontal during use or where only a portion of the full infant support surface is horizontal. Because the ASTM standard is more restrictive in what it considers to be an infant support surface that is subject to performance requirements, the definition used in the final rule results in a more stringent standard that further reduces the risk of injury associated with nursing pillows, relative to the voluntary standard.

The ASTM voluntary standard does not include definitions for "maternity pillow" or "safety alert symbol," both of which are included in the final rule. Maternity pillows are defined in the rule because they are included among the exemptions; however, the voluntary standard does not exempt these products.

The ASTM voluntary standard does not define "safety alert symbol" because this is one of the formatting elements for product warnings, and the product warning requirements refer the reader to the requirements of ANSI Z535.4, *Product Safety Signs and Labels* (ANSI Z535.4-11), which already defines this term. Thus, the omission of this

definition in the ASTM voluntary standard is inconsequential. The voluntary standard includes other definitions not included in the final rule, specifically for "fabric," "manufacturer's recommended use position," "non-paper label," "paper label," and "seam." These definitions are generally consistent with definitions included in other mandatory and voluntary juvenile product safety standards, and thus not essential for inclusion in this rule.

B. General Requirements

ASTM F3669—24 includes general requirements typically found in other ASTM juvenile product standards, such as requirements limiting lead in paints; prohibitions against small parts, hazardous sharp edges or points, and removable components that are accessible to the infant; requirements for toy accessories that are attached to, removable from, or sold with the products; and permanency requirements for product labels and warnings. The voluntary standard's requirements for Lead in Paints, Small Parts, Hazardous Sharp Edges or Points, Removal of Components, and Permanency of Labels and Warnings, and the associated test methods for those requirements, match the same requirements and test methods in the final rule (§ 1242.3(a)–(e)), with one exception: the voluntary standard's Tension Test (section 7.7.4) in the Removal of Components test method does not specify the tension test adapter clamp that may be used if the gap between the back of the component and the base material is 0.04 inches or more. Although the use of such a clamp is optional, the rule's provision of this information is helpful to testers.

ASTM F3669—24 adds a requirement for toy accessories that are attached to, removable from, or sold with a nursing pillow. This requirement is not in the final rule, but CPSC is not aware of any incidents involving toys connected to these products. In addition, the ASTM voluntary standard includes a general requirement that nursing pillows that can be converted into another product or that has features for which a consumer safety specification exists must comply with the applicable requirements of all applicable standards.

C. Performance Requirements

ASTM F3669—24 includes five performance requirements intended to address safety hazards specifically associated with nursing pillows:

- *Infant Restraints*: This requirement prohibits nursing pillows from including an infant restraint system,

which could entangle an infant and could suggest to caregivers that it is acceptable to leave an infant unattended on the nursing pillow. Aside from editorial differences, the requirement matches the same requirement in the final rule (§ 1242.4(c)).

- *Firmness*: This requirement limits the amount by which certain portions of the product can deflect, or displace, when a 3-inch diameter hemispheric probe is applied with a certain force. Testing is performed at three locations at least 3 inches apart on each of two surfaces: the infant support surface and the inner wall of the caregiver opening (*i.e.*, the surface of the nursing pillow intended to fit against the caregiver's torso during use). After the product is cleaned according to the manufacturer's instructions, the tests are repeated. Although written in the ASTM standard as a three-part requirement (*i.e.*, infant support surface firmness, inner wall firmness, and product conditioning firmness), rather than a single requirement that refers to three separate test methods as in the final rule (§ 1242.4(a)), this requirement is functionally equivalent to the firmness requirement and associated test methods in the final rule, with one exception: the ASTM firmness test method specifies that if the design of the product does not allow for testing three locations that are 3 inches apart, then firmness testing is performed on three separate available locations. The firmness test method in the final rule does not specifically address products that might not allow for testing three locations that are 3 inches apart. The ASTM voluntary standard and the final rule also differ in specific procedure to arrive at the final, stabilized firmness measurement for each location, but the two procedures are functionally equivalent.

- *Infant Containment*: This requirement is intended to reduce the potential for an infant's head to become entrapped within the caregiver opening, and to reduce the extent to which these products are used for infant propping or lounging, by limiting the amount of lateral support available to young infants if they were placed within the opening. The requirement applies a 9-inch diameter head probe to the caregiver opening of a nursing pillow. No contact is permitted between the outer half of the probe and the inner wall of the caregiver opening, and the probe must extend beyond the caregiver opening. When the probe is moved laterally out of the caregiver opening, the outer half of the probe must, again, not contact the inner wall of the product. If the product includes a

caregiver attachment, which is intended to secure the product to the caregiver, the test is performed twice: once with the caregiver attachment unsecured, and again with the caregiver attachment secured and adjusted to its minimum length. Aside from editorial differences and additional figures that illustrate the various elements of the test method, the ASTM requirement and associated test method are functionally equivalent to those in the final rule (§ 1242.4(b)).

- *Seam Strength*: This requirement is intended to address product integrity issues, such as seam failures and material breakage, by applying a specified pull test along each seam and attachment point. Other than editorial differences, this requirement and its associated test method match those in the final rule (§ 1242.4(d)).

- *Caregiver Attachment Strength*: This requirement is intended to address possible failures of the caregiver attachment by requiring each element of the caregiver attachment system (e.g., strap, buckle) to withstand a static load of 20 pounds. Other than editorial differences, this requirement and its associated test method match those in the final rule (§ 1242.4(e)).

D. Marking, Labeling, and Instructional Requirements

ASTM F3669—24 includes marking, labeling, and instructional literature requirements, which include requirements for warnings that must appear on nursing pillows covered by the standard.

The warning label in ASTM F3669—24 is nearly identical to the warning in the final rule (§ 1242.6), which was amended based on public comments on the NPR, as discussed in detail in section V and section VI.E. However, the final rule includes an additional warning statement: “Move baby to an infant sleep product, like a crib or bassinet, if baby falls asleep or if you feel drowsy.” This statement reinforces the safe-sleep message that consumers should move the baby to a product intended for infant, like a crib or bassinet, if the baby falls asleep during or after feeding, and reminds consumers to stop using the product if the consumer feels themselves falling asleep, which is a scenario associated with three infant fatalities.

ASTM F3669—24 requires the warnings to be permanent and “conspicuous,” which the voluntary standard defines as “visible to the caregiver when the product is being placed onto their body in the manufacturer’s use position.” Other than editorial differences, the definition of “conspicuous” is equivalent to the

definition included in the final rule, which was amended based on public comments on the NPR, as discussed in section V and section VI.E.

The voluntary standard also includes requirements for the product package to include warnings against using nursing pillows for sleep or in sleep products, and to state the manufacturer’s recommended weight, height, age, developmental level, or combination thereof, of the infant. In addition, the package cannot include warnings, statements, or graphics that indicate or imply that the infant may be left in the product without an adult caregiver in attendance. These requirements match the requirements in the final rule (§ 1242.6(f)).

Lastly, ASTM F3669—24 includes requirements for instructional literature to be provided with products covered by the standard. In addition to repeating the warnings on the product, the instructions must warn consumers to: (1) read all instructions before using the product; (2) keep the instructions for future use; and (3) not use the product if it is damaged or broken. The instructions also must indicate the manufacturer’s recommended maximum weight, height, age, developmental level, or combination thereof, of the infant. If the product is not intended for use by a child for a specific reason (e.g., a disability that would prevent safe use of the product), the instructions must state this limitation. These requirements match the requirements in the final rule (§ 1242.7).

Staff assesses that ASTM F3669—24 largely aligns with the final rule, with the primary exceptions being related to scope—with the final rule defining nursing pillows to include slipcovers sold on or together with the nursing pillow, while the ASTM voluntary standard does not mention slipcovers—and the product warning—with the final rule including an additional warning statement instructing the consumer to move the baby to an infant sleep product if the baby falls asleep or if the caregiver feels drowsy. In all, the final rule is more stringent and protective of infants than the ASTM voluntary standard.

Although, as explained, there are many similarities between the ASTM voluntary standard and the Commission’s rule, we choose not to incorporate portions of the ASTM standard into our rule at this time, for two reasons. First, the Administrative Procedure Act (APA) prevents incorporation by reference of a number of the ASTM provisions that differ from the NPR’s provisions absent an additional notice and comment period.

Such a process would delay unnecessarily adoption of this rule, and the Commission declines to do so. See 5 U.S.C. 553. Second, the CPSC rule contains a number of provisions that are more stringent than the ASTM standard. Adoption of a piecemeal rule, even after an additional notice and comment period, containing some elements of the ASTM standard along with the more stringent requirements of the Commission rule would risk needless complexity and industry confusion. To the extent changes are made to the voluntary standard in the future such that it conforms to the final rule, the Commission may consider incorporating the standard by reference at that time.

V. Response to Comments

The Commission received 129 comments on the NPR before the comment period closed on November 27, 2023.¹² The Commission also received three public comments on the NOA before its comment period closed on May 23, 2024.

You can access comments by searching for docket number CPSC–2020–0023 at <http://www.regulations.gov>. The topics addressed in these comments fell into several broad categories: (1) scope of the rule; (2) performance requirements; (3) marking and labeling requirements; (4) effective date; (5) small business issues; and (6) procedure. Below we summarize and respond to the comments by topic. Public comments related to the effective date and small business issues are discussed in their respective sections, X and XI.

A. Scope of the Rule

1. Slipcovers

Comments: First Candle, the Boppy Company, the Juvenile Products Manufacturers Association (JPMA) and the Breastfeeding Infant Development Support Alliance (BFIDSA) requested, in response to the NPR, clarification whether removable nursing pillow covers, or slipcovers, are included within the scope of the rule. The Boppy Company, JPMA, and a consumer commented, in response to the NOA, on whether nursing pillow covers, or slipcovers, should be subject to the requirements of the rule. The consumer comment stated that nursing pillow covers, or slipcovers, and anything else that is sold as part of the product (e.g.,

¹² The rulemaking docket for the Safety Standard for Nursing Pillows (CPSC–2023–0037, <https://www.regulations.gov/document/CPSC-2023-0037-0002>) includes nearly 850 emails received prior to the comment period that are essentially identical to these 53 public comments.

buttons, zippers) should be included within the nursing pillow definition and subject to the requirements of the rule. The Boppy Company and JPMA stated that slipcovers should not be subject to the requirements of the rule and the Commission should instead work with ASTM to create a relevant slipcover rule through the Infant Bedding subcommittee. The asserted bases for these two comments include the following:

- Slipcovers are nondurable accessories to nursing pillows, and regulating these accessories under the proposed rule is an overreach of the Commission's legal authority. The comments state that slipcovers sold with nursing pillows should be excluded from the definition of nursing pillows, with one of the comments stating that even slipcovers that are sold pre-installed on the nursing pillow are not subject to CPSIA section 104 regulation, as accessories.

- Regulating slipcovers under the proposed rule for nursing pillows contradicts the precedent set for crib mattresses, which similarly must have a permanent warning, and crib sheets, which are sometimes sold with crib mattresses and would cover up such a warning. Moreover, one of the comments asserts that crib mattresses are even more likely to be used with a sheet than a nursing pillow is to be used with a slipcover.

- Regulating slipcover manufacturers who also manufacture nursing pillows while excluding aftermarket slipcover manufacturers is improper, arbitrary, and capricious. Because most aftermarket slipcover manufacturers are based in China and do not manufacture nursing pillows, commenters state that such action is discriminatory towards U.S. small businesses.

JPMA stated that data do not support that slipcovers present a distinct hazard that should be regulated.

Response: Although not all nursing pillows include slipcovers, some nursing pillows are marketed and sold with slipcovers and these covers, though removable (e.g., for washing), are intended, marketed and designed as part of the product to position and support an infant close to a caregiver's body while breastfeeding or bottle feeding, as defined in 16 CFR 1242.2. For example, some products are sold with a slipcover that directly encases the filling material of the product; that is, the slipcover does not cover another exterior fabric cover or casing that itself contains filling material. In such cases, the nursing pillow is not intended to be used without a slipcover.

Staff also found that for nursing pillows with both slipcovers and caregiver attachments, the caregiver attachment is typically sewn onto, or otherwise a part of, the slipcover. Thus, the caregiver attachment, which allows the nursing pillow to perform its intended function by ensuring the product can rest upon, wrap around, or be worn by a caregiver in a seated or reclined position, as defined in 16 CFR 1242.2, cannot be used without the slipcover being installed on the product.

Lastly, there are nursing pillows that can be used without a slipcover but are sold with a slipcover on or accompanying the nursing pillow. This indicates that these nursing pillows are intended, marketed, or designed to be used with the slipcover that is provided with the product. Such slipcovers are also considered to be part of the nursing pillow as defined in 16 CFR 1242.2.

Considering these findings, the Commission clarifies that nursing pillow slipcovers installed on a pillow, or sold together with a pillow for a single price, are considered a part of the nursing pillow product, and therefore are within the scope of the final rule. The Commission has authority to regulate consumer products under the CPSA, which defines consumer products to include their component parts. 15 U.S.C. 2052(a)(5). Accordingly, the Commission is finalizing the definition of "nursing pillow" to include any removable covers, or slipcovers, sold on or together with the product. The Commission also clarifies that slipcovers that are sold separately, not on or together with a pillow, are not within the scope of the final rule because they are not component parts intended, marketed or designed as part of the product.

In response to the commenters' suggestion that a slipcover cannot be regulated because it is an accessory, there are no exemptions in the CPSA for "accessories" nor is the term "accessories" included in the definition of a "consumer product." Regardless, the Commission does not consider a slipcover sold on or together with a nursing pillow to be an accessory, but rather to be a component part of the consumer product subject to this final rule, the nursing pillow.

Comments asserting that the *Safety Standard for Crib Mattresses*, 16 CFR part 1241, which excluded crib sheets, sets a precedent contradicting this regulation are not persuasive. The decision to exclude crib sheets from the crib mattress mandatory standard was based on the nature and use of the product with other products. 87 FR 8640 (Feb. 15, 2022). Unlike crib sheets,

which are frequently interchangeable and, as commenters describe, are sometimes used by consumers for other products such as playpens, play yards, and bassinets, a slipcover provided with a nursing pillow can only be used for, and is intended to be used as part of, a nursing pillow. In addition, unlike cribs, nursing pillows are sold in a variety of shapes and sizes, and therefore slipcovers are designed to fit a specific brand and model of nursing pillow.

The comment stating that slipcovers do not pose a distinct hazard does not recognize the concern that these parts would cover the permanent warning on rule-compliant nursing pillows. Nursing pillow slipcovers that lack the final rule's required product warnings therefore could reduce consumer awareness of the hazards associated with nursing pillows. For this reason, the Commission urges ASTM to address hazards associated with slipcovers that are sold separately. In the meantime, the Commission encourages all manufacturers of out-of-scope slipcovers to protect infants against death and injury by ensuring that their products are consistent with the marking and labeling and other requirements of this safety standard.

Regarding the comment that the rule is discriminatory against U.S. small businesses because it does not include aftermarket or third-party manufacturers of slipcovers that are described as being produced mostly outside of the U.S., the final rule applies uniformly to all products within the scope of the rule, as well as all products outside its scope, independently of where they are manufactured.

2. Exemptions

Comments: The ERGO Baby Carrier, Inc. stated that, in addition to sling carriers, the final rule should exempt soft infant and toddler carriers, hip seat carriers, and products that are unable to rest flat on horizontal surfaces. The commenter stated that soft infant and toddler carriers are regulated under 16 CFR part 1226; that "hip seats," or "hip seat carriers," do not have a standard but are often used with an infant partially supported by the caregiver and product, and could foreseeably be viewed as having a slightly u-shaped base that slightly conforms to the caregiver's body and brings the product within the definition of a nursing pillow; and that products that are unable to rest flat on a horizontal surface in its intended use position are unlikely to be used as an infant support product.

Response: The Commission recognizes that, like nursing pillows, soft infant and toddler carriers position and support an infant close to a caregiver's body and could possibly be used for nursing or bottle feeding. However, unlike nursing pillows, soft infant and toddler carriers are intended primarily for carrying the infant or child and are unlikely to be used for independent infant propping, lounging, or sleep. In addition, as noted in one of the public comments, these products are already regulated under 16 CFR part 1226. Therefore, the Commission is exempting soft infant and toddler carriers from the final rule for nursing pillows.

Although the "hip seats" described in the comment are similar to soft infant and toddler carriers, in that they are intended primarily for carrying the infant or child and are unlikely to be used for independent infant propping, lounging, or sleep, a mandatory standard for these products does not yet exist. Thus, the Commission concludes that an exemption for hip seats from the final rule is not appropriate, and that hip seats intended, designed, or marketed for breastfeeding or bottle feeding, and that otherwise meet the definition of a nursing pillow, will be considered a nursing pillow under the final rule.

The Commission disagrees with the suggestion to exempt products that are unable to rest flat on a horizontal surface in their intended use position because there may be nursing pillows with an uneven bottom surface that still lend themselves to infant propping or lounging. Therefore, the Commission concludes that all nursing pillows, regardless of shape, are subject to the requirements of the final rule.

3. Use of Substitute Products

Comments: Seven consumers, five anonymous individuals, a product safety consultant, Perspective Enterprises, the Boppy Company, and BFIDSA, claimed that consumers may use substitute products such as bed pillows or throw pillows, or may obtain noncompliant products from the secondhand market, instead of using nursing pillows that comply with the final rule. Most of these comments asserted that the use of substitute products instead of compliant nursing pillows will be due to the rule's firmness requirement (specifically, mattress-like firmness), the infant containment requirement, or both. Commenters attribute the reason for consumers using substitute products to comfort levels for the infant, caregiver, or both; difficulty of use; heavier weight

and transport difficulty; laundering issues; and reduced amount of support surface for one or more infants. One consumer suggested that CPSC consult an expert on nursing products and user experience and design the products to adequately address those concerns. Kids in Danger expressed support for the requirements in the NPR, stating that they will lead to safer products without a negative impact on the use of the product as a nursing pillow.

Response: CPSC acknowledges that some consumers already choose to use products other than nursing pillows, such as bed pillows or rolled up towels, to support infants during breastfeeding. In fact, some websites that promote breastfeeding indicate that consumers often already use these other products, rather than dedicated nursing pillows, for breastfeeding and find nursing pillows to be unnecessary. The CPSIA requires CPSC to promulgate safety standards for all categories of durable infant and toddler products, even if consumers also use alternatives to those products. Ensuring that nursing pillows prevent hazards that could result in serious injury or death to infants, however, both complies with this Congressional directive and is likely to encourage safety-conscious caregivers to use nursing pillows that meet a mandatory safety standard instead of unregulated alternatives that may pose hazards for infants.

The incident data show that the primary hazard associated with nursing pillows is the use of these products for lounging and sleeping, not breastfeeding, and the design of most nursing pillows on the market lends themselves to lounging and sleeping. Nursing pillows that are soft and can envelop and support an infant for lounging are likely to continue to be used in this way if the Commission does not finalize this safety standard. The CPSIA requires that the Commission act to prevent these hazards.

Regarding the firmness and infant containment requirements, some nursing pillows on the market already have firmness and caregiver opening dimensions that would meet the requirements of the rule, and consumers have purchased and successfully used these products.¹³ Staff is not aware of widespread reports or complaints of these products being less comfortable or more difficult to use in comparison to other products without these features.

¹³ Analysis by staff of CPSC's Directorate for Economic Analysis (EC) finds that one of the nursing pillows currently on the market that meets the final rule's firmness requirement is a Top 10 bestseller on *Amazon.com* and sells more than 18,000 units per month on Amazon alone.

Moreover, contrary to comments arguing that the firmness requirements will result in heavier products that are more difficult to transport, one of the nursing pillows on the market that meets the final rule's firmness requirement is one of the lightest nursing pillows examined by staff.¹⁴

Further, while the infant containment provision would reduce the amount of the nursing pillow that wraps around the caregiver for some existing products and could reduce the overall available infant support surface, infants generally do not take up the entire infant support surface of existing nursing pillows during use, and as noted above, consumers are successfully using products that already would meet the infant containment provision.

4. Impact on Breastfeeding

Comments: Many commenters, including 71 consumers, one anonymous individual, Perspectives Enterprises, the Boppy Company, a Boppy consultant, and BFIDSA, discussed the possible impact of the rule's requirements on breastfeeding. Most of these comments assert that the NPR failed to consider data around the safety, utility, and intended purpose of nursing pillows, and the required changes to nursing pillows will reduce the availability of nursing pillows and have a negative effect on breastfeeding and its associated benefits. One of the commenters, a Congressional representative, asserted that these requirements fundamentally alter the function of the product and effectively prohibit the use of nursing supports for breastfeeding mothers. Commenters reasoned that this is due to reduced comfort for the infant, caregiver, or both; reduced ease of use; increased weight and difficulty in transporting; and difficulty laundering the product. Some comments from consumers also expressed concerns about rule-compliant nursing pillows having to use crib mattress material or being less adjustable to the caregiver's body shape.

Response: None of the comments provide data to support the claim that the requirements in the proposed rule would adversely affect the effectiveness or prevalence of breastfeeding. To the contrary, ensuring that nursing pillows are compliant with a safety standard that prevents known hazards resulting in injury or death could encourage

¹⁴ One nursing pillow that Boise State University (Mannen et al., 2022) found to meet the firmness requirement weighed 0.48 kg (1.06 lb.). This was the lightest of all examined nursing pillows, which weighed up to 1.84 kg. Even the next lightest nursing pillow was nearly twice the weight, at 0.88 kg (1.94 lb.).

caregivers to use compliant nursing pillows, due to concerns for infant safety. According to CPSC staff's testing, some nursing pillows on the market already have infant support surfaces with a level of firmness that is consistent with the level specified in the proposed rule and have caregiver openings that would meet the proposed infant containment provision. These findings indicate that such requirements are unlikely to decrease the utility of nursing pillows for breastfeeding, particularly because nursing pillows with these already-compliant features tend to be single-function products that are designed specifically for this activity. Furthermore, nursing pillows that do *not* comply with the rule's infant containment provision are less likely to fit a caregiver to enable nursing; their small openings generally appear designed and intended to fit and support a small infant for lounging.

The rule does not require nursing pillow manufacturers to use crib mattress material. The rule establishes a firmness standard but does not dictate the product's material or construction. The Commission is also not aware of widespread reports or complaints of existing nursing products that have increased firmness and are less capable of containing an infant being less adjustable or fitting poorly in comparison to other nursing pillows.

5. Product Misuse and Education

Comments: CPSC received comments from 20 consumers, 13 anonymous individuals, Perspective Enterprises, Kids In Danger, a product safety consultant, and JPMA, expressing concerns with consumers' alleged misuse of nursing pillows, disregard for warnings, or allegedly inattentive/neglectful/irresponsible parenting. Many of these commenters suggested increased and consistent education, educational campaigns, or safety alert/guidelines about safe sleep, appropriate nursing pillow use, and similar topics, and either implied or explicitly stated that changes to the products are not needed. Several commenters, however, pointed out that nursing pillows already have warnings that directly address sleep and other misuse patterns. A childbirth and nursing educator commented that while education is important, it is not enough to address the hazards. One commenter, Kids in Danger, recommended that more education should be combined with adoption of the requirements in the NPR.

Response: The Commission agrees that using nursing pillows for sleep or naps is hazardous and that education

about safe sleep and the safe use of nursing pillows is important and useful. However, the Commission also agrees with the comment that states that education alone is not enough to address the hazards associated with nursing pillows. As noted in the comments, virtually all nursing pillows on the market already warn against using the products for sleep, which is a foreseeable use pattern given that infants are likely to fall asleep or to be put to sleep on products intended for lounging or rest, and many nursing pillows either are or have been marketed for infant lounging.

The improved product warnings and instructional requirements in the final rule should increase the likelihood that affected consumers will be better informed about the dangers of using nursing pillows for sleep and may reduce unsafe use of nursing pillows. However, providing warnings and instructions about hazards is less effective at eliminating or reducing exposure to hazards than either designing a hazard out of a product or guarding the consumer from a hazard. Indeed, the commenters' recognition that consumers are disregarding existing warnings confirms the limited effectiveness of warnings in addressing this issue and supports the need for performance requirements. Educational campaigns or programs might offer more opportunities to present hazard information in varied ways and in greater detail than traditional warnings, but these programs suffer from similar limitations and cannot be expected to eliminate hazardous use.

B. Performance Requirements

1. Small Parts Requirement

Comment: An anonymous commenter stated that the rule should specify that the foam cores of nursing pillows must pass small parts testing, because they are accessible on some products currently on the market, once the zipper is opened.

Response: All nursing pillows are subject to the small parts testing, 16 CFR 1242.3(b), which requires that there shall be no small parts before testing or liberated as a result of testing. The Commission agrees that products filled with foam and a covering secured with a zipper would allow access to the foam filling, if the zipper were opened, and CPSC staff is aware of nonfatal choking incidents involving infants placing accessible filling into their mouths. This potential hazard is addressed by the rule's tension test requirement for nursing pillow components that are accessible to an infant, which includes

a zipper pull. Any part, including filling, that is liberated thereafter is subject to the small parts requirement. The rule also includes a firmness test procedure that requires the product to be laundered according to the manufacturer's instruction. Any part, including filling, that is liberated as a result of this test will also be subject to the small parts testing requirement.

CPSC, however, is not aware of any incident reports where an infant has accessed a foam core of a nursing pillow by opening the zipper. Thus, adding a specific requirement to address the scenario described by the commenter is not supported by the data at this time. CPSC will continue to monitor incidents after the rule becomes effective.

2. Infant Restraint Prohibition

Comments: Comments from three consumers, a Boppy consultant, the American Academy of Pediatrics (AAP), Kids in Danger, a product safety consultant, Consumer Reports, the Consumer Federation of America and the National Center for Health Research (CFA/NCHR), and Safe Kids Worldwide agreed that infant restraints and harnesses should not be permitted. In contrast, a comment from China's WTO/TBT National Notification & Enquiry Center and China's National Center of Standards Evaluation, Notification and Comment Center on TBT of the State Administration for Market Regulation (collectively, SAMR) expressed support for infant restraints and stated that these features are intended to fasten infants in a position to facilitate breastfeeding and to reduce the risks of suffocation and falls, among other risks. This commenter further added that products with infant restraints include warnings against leaving a child unattended during use. This comment also included a recommendation to further research the risk of falls for nursing pillows with restraints compared to those without restraints.

Response: The Commission will retain the prohibition against infant restraints in the final rule. There is no evidence provided to support that breastfeeding caregivers require such features for support of the infant. Caregivers actively hold and position infants while breastfeeding, and fall-related incidents of which the Commission is aware tend to involve unattended infants who were left propped or lounging in the product. Consumers may interpret the presence of an infant restraint to imply that such unattended use is acceptable.

3. Seam Strength Requirement

Comments: Commenters from the AAP, a Boppy consultant, and a product safety consultant generally supported the seam strength requirement. One consumer, a lactation consultant, commented that she is not aware of any problems with seams.

Response: Reported incident data include infants gaining access to the filling within nursing pillow products because of seam openings. Therefore, the Commission is finalizing the proposed seam strength requirement in this rule.

4. Caregiver Attachment Strength Requirement

Comment: Public comments from the AAP and Consumer Reports generally supported the requirement for caregiver attachment strength. Consumer Reports, however, stated that it was unclear how buckle- or clasp-free attachments—for example, those that rely on ties—would be assessed or if those attachment methods are prohibited.

Response: The caregiver attachment strength requirement was not intended to be applied only to buckles and clasps. The definition “caregiver attachment” states that it “may comprise components including, but not limited to, straps, buckles, or latches.” Therefore, ties are included among the components that comprise a caregiver attachment. However, to clarify that fasteners of all types are subject to the caregiver attachment strength requirement, the Commission is revising the Caregiver Attachment Strength Test Method to add “other fastener,” in addition to buckle and clasps, to better describe the range of possible elements of a caregiver attachment.

5. Firmness Requirement

Comments: Nine consumers, one anonymous individual, a Congressional representative, and Perspectives Enterprises commented that the firmness requirement, alone or possibly when combined with the infant containment requirement, will reduce or eliminate the effectiveness of the product for breastfeeding and will possibly discourage caregivers from using compliant products. Perspectives Enterprises claimed that firm nursing pillows are not as popular as softer ones. Comments from three consumers and a product safety consultant stated that the changes will drive consumers to substitute products, such as adult pillows, or to the secondhand market, possibly increasing the risks to infants. One comment from an anonymous individual questioned whether there is

any research on the negative effects of a firmer surface and whether it is possible that current products have made breastfeeding safer overall.

Comments from 13 consumers, one anonymous individual, a product safety consultant, and Perspectives Enterprises stated that greater firmness will reduce the comfort of nursing pillows for the infant, caregiver, or both. Nine consumers, a product safety consultant, and Perspectives Enterprises expressed concerns about mattress-like firmness, with some comments stating that nursing pillows need to have pillow-like softness or that they should be soft enough to accommodate and adjust to different caregiver body sizes and shapes.

The AAP, Kids in Danger, Consumer Reports, CFA/NCHR, Perspectives Enterprises, and a consumer supported the proposed rule’s requirement for mattress-like firmness, primarily because the requirement will effectively eliminate or reduce the likelihood of an infant’s face conforming to the product’s surface and, when combined with the infant containment requirement, will lessen the likelihood the product will be used as a lounger or sleep surface.

Comments from a testing lab representative, a safety engineer, JPMA, the Boppy Company, the ERGO Baby Carrier, Inc., and BFIDSA recommended revisions to the firmness test method, including:

- Adopting the recommended test method for firmness that was being developed by the ASTM Infant Bedding subcommittee at the time of the comment period;
- Changing the firmness probe figure to address missing information on the probe diameter, the type of material, and dimensional units, and to remove the term “recommended” from the specified probe length; this comment recommends changing the figure to mirror Figure 11 in ASTM F833—21;
- Using the probe figure from the firmness test method being developed by the ASTM Infant Bedding subcommittee; and
- Specifying that the final firmness measurement should be taken after the measured force stabilizes, which should be defined as when the force does not change by 0.1 N in 30 seconds, and that multiple firmness measurements should be taken at each test location.

Comments from a safety engineer, JPMA, the Boppy Company, the ERGO Baby Carrier, Inc., and BFIDSA expressed concerns about the accuracy of the firmness test method and the test locations proposed in the NPR, with most recommending that the rule should specify that when choosing a test

location, the edge of the test probe shall not extend beyond the edge of the product. The ERGO Baby Carrier, Inc. further recommended that the test method should specify the most pertinent parts of concern for the nursing pillow, as there may be some areas where the product tapers to a smaller dimension that is not firm but nevertheless does not present a suffocation risk.

Response: Comments regarding the impact of the firmness requirement on breastfeeding and use of substitute products are addressed earlier, in sections V.A.3 and 4. Regarding comments about the relative popularity of softer nursing pillows, soft bedding poses a known suffocation risk to infants while firmer products consistent with the rule do not have suffocation incidents. Therefore, the argument for softer products is contradictory to the rule’s intent to reduce such hazards for infants.¹⁵

Regarding the recommendation to adopt the firmness test method being developed by the ASTM Subcommittee F15.19 on Infant Bedding, the ASTM draft test method has not yet been finalized or published and it is unclear whether and when publication will occur. Staff, however, has participated in the development of this test method and continues to participate in related ASTM task group meetings.

Regarding the recommendation to reference Figure 11 of ASTM F833 in the final rule, this figure is not appropriate for the firmness test method in the final rule because it is associated with an occupant retention requirement, not a firmness requirement.

The specific recommended changes to the firmness probe figure, to add units of measure, set an overall length, and specify probe material composition and surface finish, are warranted and will improve the consistency of probe construction among testing laboratories. Accordingly, the Commission is revising the figure in the final rule as suggested by commenters. These changes will not affect the substantive outcome of firmness testing.

The comments recommending changes to the firmness test method to take the final firmness measurement only after the force has stabilized would result in an improvement to the

¹⁵ In addition, many comments express general concern about nursing pillows having to be as “hard” as crib mattresses. Yet, the final rule’s firmness requirement, which requires that the force to displace the test probe 1 inch be greater than 10 N, represents the low end of crib mattress firmness. The overall average of all tested crib mattresses during the development of this requirement was greater than 15 N.

reliability and repeatability of the test. Accordingly, the Commission is revising the firmness requirement test method by adding language to specify that the final force is based on the measurement not changing more than 0.1 N in successive 30 second periods.

It does not follow, however, that performing multiple firmness tests at the same locations, as suggested by some comments, would be beneficial. If a firmness test is repeated at the same specified location, the product surface will be compressed, and the forces required to reach the 1.00 in (25.4 cm) deflection in the subsequent tests will likely result in different, most likely higher, forces. The commenter who recommended this change, a safety engineer, does not describe how multiple results in a single location will be used to determine compliance. As proposed in the NPR, the final rule requires that the test locations are placed 3 inches apart to reduce the effect of previous tests.

The Commission agrees with the comments expressing concern about the accuracy of the test method and the testing locations where the edge of the test probe extends beyond the edge of the product. Testing with a probe that extends beyond the edge of the product would be analogous to an infant's face being only partially in contact with the product surface. Such a scenario is unlikely to result in the infant's face being enveloped by the product, and therefore is unlikely to represent a suffocation scenario. In addition, testing at an unsupported edge could result in a (false) test failure due to the deflection measurement including the edge bending away. Therefore, the final rule limits test locations to those in which the profile of the head probe is fully within the confines of the product surface. However, it is possible that some nursing pillows could be of a size or shape that would require the edge of the probe to extend beyond the edge of the product to perform firmness testing. Thus, the final rule specifies that if the design or size of the product is such that the edge of the probe must extend beyond the product, then the probe must be centered over as much of the test surface as possible. Additionally, the proposed rule did not explicitly state to zero the force gauge before the probe is advanced onto the product. This step is good laboratory practice to follow and is implied by the low force needed when setting the deflection to 0.0 inches. However, to ensure the accuracy of the test results as the probe is moved from location to location, the final rule now explicitly states to zero the force gauge after the probe has been

oriented and before the probe is advanced onto the product.

6. Infant Containment Provision

Comments: Comments from the AAP, Kids In Danger, Consumer Reports, CFA/NCHR, and Safe Kids Worldwide supported the infant containment requirements, stating that the changes based on this requirement will discourage the use of these products for non-nursing purposes such as lounging or sleeping.

Three consumers, a product safety consultant, and Perspective Enterprises stated that the infant containment requirements will negatively impact the effectiveness of breastfeeding and deter the product's use for nursing, driving consumers to use substitute products.

Comments from two consumers, a product safety consultant, the Boppy Company, and BFIDSA expressed concerns about the reduced lateral support resulting from the infant containment requirement, including claims that it will reduce the product's ability to support multiple infants, that the requirement is not supported by data, and that the requirement was not included among the recommendations in the Boise State University (BSU) report to CPSC on infant pillows (Mannen et al., 2022).

Two consumers and Perspective Enterprises expressed concerns about the infant containment provision's effect on caregiver fit, particularly for larger caregivers.

A consumer and the ERGO Baby Carrier, Inc. sought clarifications for the infant containment requirements, including distinguishing between a caregiver opening and a caregiver attachment in products where the transition between the two might be ambiguous, and identifying the recovery time between testing a product with a caregiver attachment secured and unsecured. Lastly, the ERGO Baby Carrier, Inc. commented that the minimum-length setting requirement for the caregiver attachment is not supported by incident data and that if the caregiver attachment is removable, the test should be performed without it.

Response: The Commission agrees with commenters who support an infant containment provision that will discourage the use of nursing pillows for sleep and lounging. Comments regarding the impact of the infant containment provision on breastfeeding and use of substitute products were addressed earlier, in sections V.A.3 and 4.

Regarding concerns about reduced lateral support making nursing pillows unable to accommodate multiple infants

for simultaneous breastfeeding, just as with solo infants, the potential loss of this feature is outweighed by the safety benefits of not providing lateral support that would enable young infants to be propped up in these products for lounging or sleep. Moreover, to CPSC staff's knowledge, all nursing pillows currently on the market that are designed solely for nursing or feeding would meet the infant containment provision in the final rule. The fact that the BSU report did not specifically consider a requirement for reduced lateral support for infants, and therefore did not include such a requirement among its recommendations, is not a valid reason to refrain from making this safety improvement.

The Commission disagrees with comments expressing concern about the infant containment provision's effect on caregiver fit, particularly for larger mothers. As noted in the staff briefing package supporting the NPR,¹⁶ many nursing pillows currently on the market have openings whose size and shape seem designed with the specific intention of supporting a small infant, not primarily to fit a caregiver's body, with opening sizes smaller than the waist size of even the likely smallest-waisted adult user of these products. The infant containment provision would require caregiver opening sizes that more closely match the expected shape and size of a caregiver's body. Moreover, as that briefing package also noted, adult anthropometric data demonstrate that a nursing pillow that meets the infant containment provision would still allow the sides, or "arms," of the worn product to extend more than half of the caregiver's full abdominal depth, even among caregivers with the largest abdominal depths.

Regarding the test method for assessing infant containment, the Commission agrees that for certain products that have a more gradual transition between the infant support surface and the caregiver attachment, as described by the commenter, there could be confusion about what qualifies as part of the caregiver attachment. Accordingly, the Commission is amending the definition of "caregiver attachment" in the final rule to mean, "a portion of the product that is not an infant support surface and is intended to secure the nursing pillow to the caregiver. A caregiver attachment may comprise components including, but not limited to, straps, buckles, or latches." This revised definition explicitly excludes any part of the product that functions as an infant support surface.

¹⁶ See Staff's NPR Briefing Package, 62–63.

The Commission is retaining the rule provision that provides for testing for infant containment with the caregiver attachment adjusted to its minimum length. Assessing infant containment after adjusting the caregiver attachment to its minimum length determines whether a nursing pillow with a caregiver attachment would allow the caregiver opening to be adjusted to an opening size that is useful to prop an infant who is not feeding. The requirement is intended to prevent this known hazardous use of nursing pillows.

The Commission agrees with the comment stating that the infant containment test method should require a recovery time between the steps where the caregiver attachment is secured at the minimum allowable length and tested with the 9-inch probe, and where the attachment is then unsecured and the test repeated. Securing a caregiver attachment typically draws together the sides of the caregiver opening, which may leave the opening temporarily deformed after the caregiver attachment is released, resulting in a caregiver opening that is temporarily smaller. To address this, the final rule reverses the order of the steps in the Infant Containment test method, so the product is tested first with the caregiver attachment unsecured, and then with the caregiver attachment secured at its minimum length. By applying this revised sequence to the test method, a waiting period is not needed between the two tests, because the unsecured test does not affect the secured test. The Commission also revised the accompanying figure to account for the revised sequence and to more clearly illustrate passing and failing nursing pillows, both with and without caregiver attachments.

7. Air Flow Requirement

Comment: A product safety consultant, the AAP, Consumer Reports, and Safe Kids Worldwide provided comments that addressed the airflow requirement that the Commission considered, but did not include, in the proposed rule. All of these commenters, except for Safe Kids Worldwide, agreed with the Commission's decision not to include an airflow requirement, stating that such a requirement is unnecessary or inappropriate. Safe Kids Worldwide appeared to believe that such an airflow requirement was included in the proposed rule. The AAP recommended that the Commission continue to monitor incidents and to consider adding an airflow requirement in the future, if necessary.

Response: Consistent with the NPR and the comments, the Commission does not include an airflow requirement in the final rule.

8. Angular Requirement

Comments: Comments from a product safety consultant, the Boppy Company, and BFIDSA agreed with the Commission's decision not to include an angular requirement (*i.e.*, requiring nursing pillows to have sharper edges or corners, rather than cylindrical sides) in the proposed rule. These commenters stated that an angular requirement would make nursing pillows uncomfortable for nursing, that it is unclear what would be an appropriate test method to assess the hazard and to determine compliance with such a requirement, and that the requirement is unnecessary and redundant for safety, as the suffocation risk is addressed by the other performance requirements in the rule. Kids in Danger recommended that the Commission consider adding an angular requirement in the future if propping or similar lounging-related uses continue.

Two commenters, AAP and Consumer Reports, stated that an angular requirement should be added to the rule because it is necessary to convey to caregivers that the products are not suitable for uses other than nursing or feeding. CFA/NCHR also recommended adding an angular requirement, stating that the requirement will ensure there is no reasonable way to prop up or lounge a baby on the product.

Response: CPSC continues to have concerns about appropriate pass-fail criteria for an angular requirement and the potential risks associated with such a requirement, which include the risk of positional asphyxia by neck hyperflexion or hyperextension if the nursing pillow is used as a support cushion for lounging, particularly because many nursing pillows on the market that are intended solely for nursing, which have not been involved in fatalities, are not "angular." In addition, the final rule's infant containment provision is likely to achieve the goal of discouraging infant lounging by limiting the amount of lateral support these products provide to an infant. Thus, the Commission agrees with the comments supporting the NPR's proposal not to include such a requirement at this time.

C. Marking and Labeling Requirements

1. General

Comments: Eight comments, from three consumers, the AAP, Kids in Danger, Consumer Reports, CFA/NCHR,

and Safe Kids Worldwide, generally support the product warning and labeling requirements in the proposed rule, with three specifically supporting the warning permanence requirement intended to prevent free-hanging labels. A consumer and SBA's Office of Advocacy took the view that warning requirements alone are sufficient to address the hazards and performance requirements are not necessary.

Response: Providing warnings and instructions about hazards is less effective at eliminating or reducing exposure to hazards than either designing the hazard out of a product or guarding the consumer from the hazard. Virtually all nursing pillows on the market already warn against using the products for sleep, yet consumers continue to use the products in this way. Thus, although improved warnings can help, the Commission disagrees with the comments stating that warnings alone should be sufficient to address nursing pillow hazards.

2. Warning Content

Comments: Perspective Enterprises and BFIDSA objected to the proposed warning's initial sentence about sleep and naps, stating that the sentence is unnecessarily alarming, with BFIDSA stating that the sentence should be changed to be consistent with other juvenile product standards that typically describe a hazard causing "serious injury or death." This latter comment also disagreed with use of the terms "turn" and "scoot" in the warning, stating that they are unnecessary, and stated that nursing pillows can be used safely for naps in the lap of a caregiver, under direct supervision and supported by the caregiver's arms. A product safety consultant and a consumer suggested an alternative, briefer warning to improve the likelihood that it will capture attention and will be read by consumers. These two comments recommend limiting the text of the warning, after "WARNING," to the following: "Do not use for infant sleep. Baby can move during sleep and suffocate against nursing pillow." The consumer stated that the smaller size of the resulting warning would allow it to fit entirely in a conspicuous location and stated that the warning could include a reference for additional guidance, if needed. Lastly, CFA/NCHR recommended the addition of non-English language warnings and instructions, as well as diagrams that can be easily understood, regardless of language.

Response: The Commission disagrees with the comments claiming that the

proposed rule's initial warning statement, "USING THIS PRODUCT FOR INFANT SLEEP OR NAPS CAN KILL," is unnecessarily alarming. The use of nursing pillows for sleep is the most common fatal hazard pattern for these products, even though warnings about the potential for death by suffocation if the products are used for sleep are prevalent on nursing pillows. The continued use of these products for sleep despite these warnings indicates that current messaging is not sufficient. The comments' primary concern with the initial warning statement appears to be the use of the phrase, "CAN KILL," and the ASTM Nursing Pillows subcommittee received similar comments from ASTM F15 members, with some claiming that "kill" implies intentional violence and is not appropriate for a juvenile product. The Commission does not agree with these claims. However, in the final rule, the Commission is replacing "CAN KILL" because consumers may interpret this language as referencing something hypothetical that may not happen to their child. Instead, the Commission is finalizing the following statement that more concretely states the hazard: "BABIES HAVE DIED USING NURSING PILLOWS FOR SLEEP OR LOUNGING."

Like the original initial statement, this revised statement immediately communicates to consumers the actual and potential deadly consequences of using nursing pillows for sleep, which is the primary use pattern that has resulted in fatalities with these products. However, the revised wording also identifies the dangers of using the product for lounging and places emphasis on the fact that deaths *have occurred* when the product is used for sleeping and lounging, and thus

communicates that the stated hazard is not merely hypothetical. Mentioning actual deaths should increase the perceived threat or hazardousness of the situation, which has been shown to motivate precautionary intent and behavior (Riley, 2006; Tannenbaum et al., 2015).

The Commission disagrees with the comment suggesting that the statement be reworded to say that using the product for sleep can cause "serious injury or death." Although use of this phrase would be consistent with other juvenile product standards, the common use of this phrase elsewhere is likely to undercut its effectiveness in capturing attention and motivating warning compliance, compared to the language in the NPR and the final rule.

The Commission disagrees with the comments proposing very brief warning content that only tells consumers not to use the product for infant sleep and that the baby can move during sleep and suffocate against the nursing pillows. This omits important hazard information about, for example, consumers leaving the infant unattended in the product for reasons other than sleep (*e.g.*, lounging, propping); consumers using the product where the infant sleeps (*e.g.*, cribs, bassinets); and falls from elevated surfaces.

Nevertheless, the Commission does concur that revisions to the warning content could eliminate redundancy and potentially unnecessary information, thereby reducing the overall length of the warning without reducing the warning's effectiveness. The warning language in the final rule replaces "turn, scoot, or roll over" with "move" and "in only a few minutes" with "within minutes." The Commission also revises the warning

label to better reflect that nursing pillows are intended solely for feeding. Specifically, in the final rule the warning statement "Use only with an awake baby" will be revised to "Only use this product to feed baby."

To be more clear and actionable, the Commission also changes subsequent warning statements from "a firm, flat sleep surface" to "an infant sleep product," and from "Never use in sleep products like cribs, bassinets or play yards," to "Never place this product where baby sleeps." Furthermore, the Commission is removing warning statements that communicate redundant messages, which include: "Use only with an awake baby"; "KEEP baby in arm's reach during use"; and "Stop using if you feel yourself falling asleep." Lastly, for brevity and to emphasize a specific use that has led to falls, the Commission is revising "Never carry or move product with baby in it," to "Do not use to carry baby."

In addition to the changes outlined above, the final rule provides for the addition of a border, or line, to separate the sleep- and suffocation-related warning language from the fall-related language. Grouping the warning text into separate, conceptually related sections in this way will allow consumers to more easily differentiate between the two distinct hazards, facilitating the search and acquisition of information (Tullis, 1997 as cited in Wogalter & Vigilante, 2006). In addition, this change visually communicates to consumers the limited information that must be processed on each topic, so consumers are not overwhelmed by a single mass of text that might otherwise dissuade them from reading.

Thus, the Commission is adopting the following warning for the final rule:

▲ WARNING
BABIES HAVE DIED USING NURSING PILLOWS FOR SLEEP OR LOUNGING Babies can move without warning and CAN SUFFOCATE within minutes if their airway is blocked.
<ul style="list-style-type: none"> • Only use this product to feed baby. Move baby to an infant sleep product, like a crib or bassinet, if baby falls asleep or if you feel drowsy. • Never leave or prop up baby alone on this product. • Never place this product where baby sleeps.
Babies have been injured from FALLS.
<ul style="list-style-type: none"> • Do not use to prop up baby on beds, sofas, or other raised surfaces. • Do not use to carry baby.

The Commission recognizes the potential usefulness of providing warnings and instructions in multiple languages, and many nursing pillow manufacturers already do so. At this time, the Commission will not impose a mandatory requirement that departs from the traditional approach of only English-language warnings; however, manufacturers may add additional languages on the warnings to best reach their customers. In addition, the Commission is not aware of any pictograms or similar graphics that would effectively communicate the primary hazard or the appropriate avoidance behaviors to most consumers. Some graphics thought to be obvious are poorly understood and even can give rise to interpretations that are opposite of the intended meaning (cf. Johnson, 2006; Wogalter, Silver, Leonard, & Zaikina, 2006).

3. Warning Format

Comments: CPSC received comments from a product safety consultant and a consumer discussing the warning format. Both commenters recommend replacing the orange-and-black “WARNING” signal word panel with the word “STOP!” The product safety consultant suggested that this will address consumer habituation to warnings that have become nearly identical in appearance and format.

Response: The warning format requirements in the proposed rule are based in part on the recommendations of the ASTM Ad Hoc Language task group (Ad Hoc TG), which developed its warning format recommendations specifically to address concerns raised by ASTM F15 members about the lack of consistency in warning requirements across ASTM juvenile product

standards.¹⁷ Ad Hoc TG’s recommended requirements are further based on the requirements of ANSI Z535.4–11 which are the benchmark against which warning labels are evaluated for adequacy. Research generally shows that the individual elements or components of the ANSI Z535 format (e.g., signal word, color) can be effective in improving noticeability, perceived hazard, and intended compliance.¹⁸

Changing the appearance of a warning can be helpful in reducing the potential for habituation, and the specific revisions proposed in the comments might accomplish this goal during initial exposures to the warning while conveying a similar level of hazardousness as the warning format specified in the proposed rule.¹⁹ However, CPSC is unaware of any nursing pillows with prominent warnings affixed to the product in a conspicuous location similar to what the final rule requires; rather, most product warnings on these products appear to be on free-hanging, easily

¹⁷ In 2015, more than 30 ASTM members—representatives that included juvenile product manufacturers, independent consultants who participate in ASTM, consumer groups, and other supply-chain stakeholders—sent a letter to CPSC’s then-Chairman Kaye, expressing concern with inconsistent warning formats across the standards and seeking consensus-based, consistent warnings. See <https://cdn.ymaws.com/www.jpma.org/resource/collection/DAD0B69F-A001-4829-931E-1131DAF39D79/Warning%20Labels%20Final.pdf>.

¹⁸ See Staff’s NPR Briefing Package, 72–73.

¹⁹ The alternative signal word proposed by the comment, “STOP,” has been studied and the perceived hazardousness of this term compared to “WARNING” is mixed; the perceived hazard levels of these two terms generally appear to be similar (Wogalter & Silver, 1995). It conceivable, though, that using “STOP,” particularly if printed in red, could be at least as effective as an ANSI Z535-style “WARNING” signal word panel in communicating the hazardousness of the scenario described in the nursing pillow warning.

removable tags. Even if consumers generally are habituating to the appearance of ANSI Z535-style warnings, caregivers are unlikely to be dismissive of brief, conspicuous warnings on products intended for infants and are likely to read and process at least the initial sentence of the warning, “BABIES HAVE DIED USING NURSING PILLOWS FOR SLEEP OR LOUNGING,” which immediately communicates to consumers the deadly consequences of using nursing pillows for sleep and is likely to motivate further reading by the caregiver.²⁰ The reduced length of the warnings required by the final rule, compared to the NPR, further increases the likelihood that consumers will read the warning. The Commission thus will not change the format requirements of the warning for the final rule.

4. Warning Placement

Comments: The AAP, Perspective Enterprises, a product safety consultant, Consumer Reports, and CFA/NCHR discussed issues related to the placement of the warning on the product. The AAP, Consumer Reports, and CFA/NCHR support the proposed rule’s “conspicuous” requirement and definition. Perspective Enterprises stated that based on the proposed “conspicuous” definition, there will have to be multiple warning labels on products that can be used in various positions. A product safety consultant

²⁰ In their discussion of warning research related to attention capture and maintenance, Wogalter and Vigilante (2006) acknowledge the potential for standardized warning formats to lead to habituation but still recommend maximizing attention to visual warnings by, among other things, including “features that add prominence such as a signal word panel containing a signal word, color, and an alert symbol” (p. 261).

recommended that the warning be positioned in the “crook” or the center of the nursing pillow, where the caregiver is inclined to prop up the infant, as this will be visible regardless of the pillow position at the time of the critical decision of where to place the infant.

CPSC also received comments from two anonymous individuals, Kids In Danger, a product safety consultant, and a consumer discussing the placement of warnings or other markings on nursing pillow slipcovers. The comments indicated: warnings already exist on nursing pillows and their covers; covers could have printed instructions and diagrams; warnings should be included on any slipcovers for the product, whether sold with the product or separate, and in particular aftermarket slipcover manufacturers should be required to label just like nursing pillow manufacturers; warnings are needed on slipcovers because slipcovers can block the visibility of the warning on the nursing pillow itself; and a smaller warning label could fit entirely in conspicuous locations on both the pillow product and any covers. The Boppy Company and BFIDSA noted that a slipcover could obscure a permanent warning on the pillow, but did not explicitly state that a warning should be required on slipcovers.

Response: The Commission agrees that a revised definition of “conspicuous” is appropriate for the final rule. The proposed rule defined this term as, “visible, when the nursing pillow is in each manufacturer’s recommended use position, to a person while placing an infant into or onto the nursing pillow.” Staff worked with the ASTM Nursing Pillows subcommittee to develop this definition; however, since then, the subcommittee has expressed concerns about the definition, similar to those in the public comments. See staff’s log of the February 1, 2024, meeting of the F15.16 Infant Feeding Supports subcommittee.²¹ The definition used in the proposed rule could require multiple warning labels on certain products; for example, products with multiple infant support surfaces would likely require multiple, identical warnings.²²

The primary messages in the product warning relate to use of the product for

²¹ <https://www.cpsc.gov/s3fs-public/ASTM-F1516-Infant-Feeding-Supports-Subcommittee-Meeting-Log.pdf>.

²² For example, CPSC is aware of a nursing pillow consisting of a stack of multiple petal-shaped pillows attached to a central tubular pillow. Based on the “conspicuous” definition in the proposed rule, such a product would likely require a warning on nearly every adjustable pillow.

sleep or lounging, and incidents involving the use of nursing pillows in these ways consistently involve consumers propping or placing the infant in the caregiver opening. Thus, requiring the warning to be visible when the consumer is facing, or placing an infant into, the caregiver opening places the warning where the consumer is likely to be looking while placing an infant into or onto the product for lounging. However, some products that fall under the scope of the final rule might not have a caregiver opening, and the ASTM Infant Feeding Supports Scope task group shared the same concern. (See staff’s log of the March 19, 2024, meeting of the F15.16 Infant Feeding Supports Scope task group.)²³ Based on these considerations, the Commission concludes that a preferred approach would be to require the warning to be visible to the caregiver while placing the nursing pillow onto themselves. This would mean the warning would be in a readily visible location and would allow products with a caregiver opening to have a single warning in this location, even if there are multiple infant support surfaces. Accordingly, the Commission is revising the definition of conspicuous to be the following: “visible to the caregiver while placing the product in the manufacturer’s recommended use position on or against the caregiver’s body.”

Regarding the placement of warnings or other markings on nursing pillow slipcovers, slipcovers sold on or together with the nursing pillow are within the scope of the rule. The Commission shares commenters’ concerns about slipcovers that are sold separately from the nursing pillow covering the otherwise conspicuous warnings on rule-compliant nursing pillows and encourages slipcover makers to adopt the rule’s warning label for their products even if not legally required, and ASTM to form a working group to develop a voluntary standard for slipcovers that are sold separately.

5. Additional Warnings

Comment: One commenter, Kids in Danger, suggested that the Commission also consider an additional, removable warning with strong messaging about safe sleep and the danger posed by leaving a child in the product unattended or sleeping, that consumers must handle (*i.e.*, remove) to use the product. This message could be

²³ <https://www.cpsc.gov/s3fs-public/2024-03-19-ASTMF15-16Infant-Feeding-Supports-Scope-Task-Group-Meeting-Log.pdf>.

repeated on the product itself for future users.

Response: Considering that the final rule already includes a requirement for a permanent, prominent, strongly worded warning that will be visible to both new and future product users, the Commission concludes that a removable warning or label about safety sleep and the use of nursing pillows for sleep, as recommended by this commenter, is not warranted at this time.

D. Stockpiling Concern

Comment: Comments from the AAP and CFA/NCHR advised CPSC to take measures to avoid a sell-off of inventory for products that would be noncompliant after the effective date.

Response: Commenters who expressed a concern about potential selling off of inventory did not provide specific information as to actual stockpiling of nursing pillows that will be noncompliant under the final rule. Pursuant to 15 U.S.C. 2058(g)(1), the rule requires all products manufactured after the effective date to comply with the standard.

E. Procedure and Constitutional Issues

1. Statutory Authority

Comments: The Boppy Company, JPMA, and BFIDSA commented that the Commission is required to examine and assess the effectiveness of voluntary standards, and the Boppy Company and BFIDSA stated that the Commission can only promulgate a section 104 rule where a voluntary standard already exists.

Response: Under section 104 of the CPSIA, there is no statutory prerequisite requiring an existing voluntary standard in order for the Commission to promulgate a safety standard for a durable infant or toddler product. 15 U.S.C. 2056a(b)(2); *Finnbin, LLC v. Consumer Prod. Safety Comm’n*, 45 F.4th 127, 134 (D.C. Cir. 2022). In this instance, however, CPSC examined and assessed the effectiveness of the voluntary standard, ASTM F3669, as discussed in section IV of this preamble.

2. Regulatory Procedure

Comments: CPSC received three comments from JPMA, the Boppy Company, and BFIDSA that disagreed that nursing pillows are durable infant products subject to section 104 of the CPSIA. The comments argued that the product is primarily intended to support adult caregivers and is not for use by infants, whose contact is incidental. Commenters also asserted that nursing pillows are soft textile products that are used for a year or less. Lastly, the Boppy

Company and BFIDSA stated that nursing pillows are unlike other feeding support items and products under the original list of durable infant or toddler products in section 104 because they are soft, textile products, rather than hard, rigid, plastic, or wooden products. They also contended that while nursing pillows may be resold or “handed down,” the same can be true of nondurable goods like infant clothing.

Response: Nursing pillows meet the statutory requirement for “durable infant or toddler products” in section 104(f)(1) of the CPSIA because they are intended for use, and may be reasonably expected to be used, by children under the age of 5 years and routinely have a life span of several years with multiple children. Specifically, CPSC staff’s assessment indicates that nursing pillows are commonly purchased in “used” condition on marketplaces such as eBay, often at prices approaching half their original sale price, in addition to commonly being used by the original owner to nurse or feed additional siblings after being used for the first infant. Replacement covers are available for nursing pillows, which further confirms the extended service life of the pillow and differentiates nursing pillows from non-durable items such as infant clothing.

The Commission has previously added to the statutory list of durable infant or toddler products by including other products for young infants, such as changing products and infant bouncers, that also have a market for secondary use. As the Commission explained in 2009, “[b]ecause the statute has a broad definition of a durable infant or toddler product but also includes 12 specific product categories, additional items can and should be included in the definition.” *Requirements for Consumer Registration of Durable Infant or Toddler Products*, 74 FR 68668, 68669 (Dec. 29, 2009). Nursing pillows are intended for use by very young breast-fed and bottle-fed infants. The product is primarily designed to be used by infants to allow them to be nursed or fed successfully and comfortably by a caregiver. Contrary to commenters’ suggestion, the fact that caregivers also interact with nursing pillows and find the products useful does not negate their use by and benefit for the infant. Infant carriers, for example, are worn by caregivers and have utility for them, but are on the statutory list of durable infant products. 15 U.S.C. 2056a(f)(2)(H).

3. Data

Comments: In response to the NPR, JPMA, the Boppy Company, and

BFIDSA expressed concerns about the availability of incident data supporting the rule.

In response to the NOA, after CPSC made the data available, JPMA and the Boppy Company commented that the data was not causative and that incidents involved misuse of the product in unsafe environments despite warnings. JPMA specifically commented that focus should be on increasing consumer awareness of safe sleep and the safe use of nursing pillows, rather than re-engineering and reducing the utility of nursing pillows.

Also, the Boppy Company objected to references within the incident reports to the nursing pillow being the “first product” associated with these incidents.

One consumer commenting on the NOA stated that the incident data demonstrated the need for adopting the proposed safety standard to reduce the identified risks.

Response: In the NOA, CPSC announced the availability of incident data relied upon for the NPR. The data made available to the public for their review and comments included in-depth investigations (IDIs) and incident reports providing materials such as death certificates and information from medical examiners, consumers, and manufacturers. CPSC also released a list of NEISS data that included incidents and injuries treated in U.S. hospital emergency departments.

The Commission disagrees with the suggestion that the proposed rule is not based on causative data. As noted in staff’s NPR briefing package, at least 32 of the 154 fatalities associated with nursing pillows during the timeframe examined involved an infant who was found with their face into the nursing pillow, and an additional 13 fatalities involved an infant found in contact with the nursing pillow, with their neck hyper-flexed and the head pressed against their chest or the neck hyperextended and the head tilted backward over the top of the product. Unsafe uses for lounging or sleep are foreseeable, regardless of the presence of warnings against using these products for sleep, given that many of these products previously were marketed and seemingly intended for infant propping and lounging, and infants who are lounging or resting on the product are likely to fall asleep. The final rule’s primary performance requirements are intended to address these known hazard patterns; for example, and as discussed in the NPR, firmness reduces the potential for the product to conform to an infant’s face, which addresses incidents of infants being found

deceased with their face into the nursing pillow, while the infant containment provision reduces the likelihood that consumer can and will use the product for infant lounging or sleep. There are nursing pillows currently on the market that are intended solely for nursing that meet these requirements, and CPSC is not aware of any fatalities associated with these single-function, nursing-only products.

The Commission’s response to public comments stating that the focus should be on increasing consumer awareness of safe sleep and the safe use of nursing pillows, rather than re-engineering nursing pillows, is provided above.

Lastly, in response to the comment about references within the incident reports to the nursing pillow being the “first product” associated with these incidents, the commenter is misinterpreting the use of this term. In-depth investigation reports list the products that are associated with the incident, and these products may be identified as the “first product” and “second product.” Investigators generally give priority to products that were involved in the incident for which CPSC has manufacturer information, as opposed to products for which CPSC does not have such information, particularly if the manufacturer has a U.S. presence. The terms “first product” and “second product” do not necessarily communicate the degree to which the product in question is the cause of the incident.

3. Constitutional Issues

Comments: CPSC received comments from the Boppy Company and BFIDSA that contended the proposed rule is unconstitutional because it violates the non-delegation doctrine and the Separation of Powers and Appointments Clause of the U.S. Constitution.

Response: The final rule is promulgated under the Danny Keysar Child Product Safety Notification Act, section 104 of CPSIA, which directs the Commission to promulgate consumer product safety standards for durable infant or toddler products. CPSC is finalizing a safety standard for nursing pillows pursuant to this detailed statutory instruction.

CPSC is an independent agency and its Commissioners do not exercise Executive power, consistent with the Supreme Court’s holding in *Humphrey’s Executor v. United States*, 295 U.S. 602 (1935). Federal Courts of Appeals have recently rejected Constitutional arguments like the ones made by the commenters here. *Consumers’ Rsch. v. Consumer Prod. Safety Comm’n*, 91

F.4th 342 (5th Cir. 2024), petition for cert. filed, (*Consumers' Rsch. v. Consumer Prod. Safety Comm'n*, No. 23–1323 (petition for cert. filed on July 18, 2024)), and *Leachco, Inc. v. Consumer Prod. Safety Comm'n*, 103 F.4th 748 (10th Cir. 2024), petition for cert. filed, (*Leachco, Inc. v. Consumer Prod. Safety Comm'n*, No. 22–7060 (petition for cert. filed on Aug. 9, 2024)).

VI. Mandatory Standard for Nursing Pillows

As required in section 104 of the CPSIA, the final safety standard for nursing pillows establishes mandatory performance and labeling requirements for nursing pillows to address the risks of death and injury associated with infant suffocations, entrapments, and falls. Below we summarize the requirements in the final safety standard, including changes from the NPR.

A. Scope

The final rule defines nursing pillow as any product intended, marketed, or designed to position and support an infant close to a caregiver's body while breastfeeding or bottle feeding, including any removable covers, or slipcovers, sold on or together with such a product. These products rest upon, wrap around, or are worn by a caregiver in a seated or reclined position. As explained in section V.A.1, in response to public comments, the Commission is clarifying that slipcovers sold on or together with a nursing pillow are a part of a nursing pillow, as defined, and are therefore included within the scope of the rule. The Commission, therefore, is amending the nursing pillow definition to include clarifying language. Expressly including slipcovers within the definition and scope of the final rule further reduces the risk of injury associated with nursing pillows by requiring slipcovers that are part of the nursing pillow to include the conspicuous product warning that will inform consumers about the primary hazards with nursing pillows. The definition of "nursing pillow" is similar to the definition in ASTM F3669–24. However, as discussed in section IV, the ASTM voluntary standard does not specifically address slipcovers in its definition. The Commission encourages all slipcover manufacturers to ensure that their products align with the requirements of this safety standard to further reduce the risk of death and injury associated with nursing pillows and encourages ASTM to form a working group to develop a voluntary standard for slipcovers.

The final rule does not include the additional language used in the non-mandatory "Discussion" portion of the ASTM voluntary standard's definition of "nursing pillow," which states that the products are "typically stuffed, filled or molded foam." That language is intended to exclude sling carriers from the definition's scope without explicitly exempting these products and is unnecessary given the specific exclusions discussed below.

In the NPR, the definition of "nursing pillow" excluded maternity pillows, as defined in § 1242.2, and sling carriers, as defined in 16 CFR part 1228. In the final rule, in response to public comments discussed in section V, CPSC is retaining these exclusions and also adding an exclusion for soft infant and toddler carriers, as defined in 16 CFR part 1226, because there is an existing mandatory rule that addresses the hazards associated with those products. As discussed in section IV, ASTM F3669–24 does not define or exempt maternity pillows.

B. General Requirements

The final safety standard for nursing pillows includes many of the general requirements included in ASTM F3669–24 to address the potential hazards associated with lead in paints; small parts; sharp edges or points; and the removal of components that are accessible to infants; however, as discussed in section IV, the voluntary standard's Tension Test (7.7.4) in the Removal of Components test method does not specify the tension test adapter clamp that may be used if the gap between the back of the component and the base material is 0.04 inches or more, as is done in the final rule. Although the use of such a clamp is optional, providing this information is helpful to the tester. Like ASTM F3669–24, the final rule also includes requirements that assess the permanence of warning labels, whether paper, non-paper, or applied directly to the surface of the product, and require warning labels that are attached with seams to remain in contact with the fabric around the entire perimeter of the label when the product is in all manufacturer-recommended use positions. Thus, the final rule includes general requirements that are substantially the same as those in the ASTM voluntary standard.

The final rule, however, does not include the ASTM voluntary standard's general requirements for toy accessories that are attached to, removable from, or sold with a nursing pillow, and for nursing pillows that can be converted into another product or that have features for which a consumer safety

specification exists to comply with the applicable requirements of all applicable standards. The Commission did not propose these two additional general requirements at the NPR stage, and therefore, these requirements were not subject to public notice and comment procedures of the APA. As a result, consistent with procedural requirements for rulemaking, the final rule does not include these provisions at this time.

C. Performance Requirements

1. Infant Restraint Prohibition

To address a potential entanglement hazard, the final rule prohibits nursing pillows from including an infant restraint system. This requirement is substantially the same as Infant Restraint requirement (section 6.1) in ASTM F3669–24. Proper use of a nursing pillow involves actively attending to the infant during use for feeding, and the presence of restraints could suggest to consumers that infants properly can be left unattended on the product.

2. Seam Strength

The seams of the nursing pillows secure the filling material that, if released, can be swallowed by the infant. The Commission is aware of incidents involving seams opening and incidents in which infants accessed, and in one case choked on, filling materials. To address potential injuries associated with seam failures, the final rule adopts the NPR's requirement that nursing pillows not fail at any seams or points of attachment when subjected to a seam strength test similar to the tension test applied to toys intended for children up to 18 months old under ASTM F963, *Standard Consumer Safety Specification for Toy Safety* (the toy standard),²⁴ but tested at a higher tension force of 15 pounds rather than 10 pounds. However the final rule corrects a unit conversion error in the proposed rule, which incorrectly identified 0.5 pounds as equivalent to 1.1 N, rather than 2.2 N. The corrected requirement of the rule is substantially the same as the Seam Strength requirement (section 6.6) in ASTM F3669–24.

3. Caregiver Attachment Strength

To address the potential for infant falls if the buckled belts, straps, or other features intended to secure the product to the caregiver fail, the final rule includes a requirement and test method for the strength of caregiver

²⁴ Incorporated by reference in 16 CFR part 1250, *Safety Standard Mandating ASTM F963 for Toys*.

attachments. Specifically, the final rule requires that each element of the caregiver attachment system (*e.g.*, strap, buckle) that is included on nursing pillows be required to withstand a static load of 20 pounds. The test method also has been revised slightly for the final rule to clarify that the requirements apply to all fasteners, not just buckles or clasps. This requirement is substantially the same as the Caregiver Attachment Strength requirement (section 6.7) in ASTM F3669—24; however, the definition of “caregiver attachment” in the voluntary standard is more limited in scope by referring to the caregiver attachment as a “device or other mechanism” rather than more broadly as a “portion of the product.” Thus, the definition included in the final rule is more stringent than the voluntary standard and further reduce the risk of injury associated with the use of nursing pillows.

4. Firmness

To reduce the likelihood that the nursing pillow will conform to an infant’s face and suffocate the child, the final rule includes a firmness requirement that applies to each nursing pillow’s infant support surface, as well as the inner wall of the nursing pillow’s caregiver opening (*e.g.*, the wall within the crescent-like opening). The firmness requirement and test method are based on the recommendations of the BSU Final Report, with modifications including a requirement to test the inner wall of the opening. The test applies a 3-inch diameter hemispheric probe, which is similar in size and shape to an infant’s face, to three test locations on each surface: one at the location of maximum thickness and two others at locations most likely to fail. To avoid passing pillows with soft areas, and to minimize any influence that conducting the test can have on the firmness of foam near the test location, these test locations must be at least 3 inches apart. In addition, addressing public

comments, the final rule specifies that the locations must be selected so the edge of the probe does not extend beyond the edge of the product—unless the design or size of the product is such that the edge of the probe must extend beyond the product, in which case, the probe must be centered over as much of the test surface as possible—and the force gauge must be set to zero before the probe is advanced onto the test surface on the product.

To meet the firmness requirement, the force required to displace the probe 1 inch into each test location must exceed 10 N (about 2.25 pounds), which results in product firmness that is comparable to the minimum firmness of crib mattresses. In response to public comments, the final rule revises the test method to specify that the final force measurement at each test location is taken only after the force measurement has stabilized, meaning that it has not changed more than 0.1 N over 30 seconds. After laundering the product according to the manufacturer’s instructions, the infant support surface and inner wall firmness tests are repeated. The final rule requirement is substantially the same as the three firmness requirements in ASTM F3669—24 (section 6.2 Infant Support Surface Firmness, 6.3 Inner Wall Firmness, and 6.4 Product Conditioning Firmness). However, as discussed in section IV, the ASTM firmness test method specifies that if the design of the product does not allow for testing three locations that are 3 inches apart, then firmness testing is performed on three separate available locations. The firmness test method in ASTM 3669—24 also includes additional figures not included in the proposed rule to illustrate the firmness probe and relevant aspects of the test method. Although not within the scope of the current proceeding as defined by the NPR, the Commission could assess the potential safety implications of these differences in a future proceeding to

consider incorporating the ASTM voluntary standard by reference.

As discussed in section IV, the voluntary standard also defines certain terms that are used in the Firmness test method differently than the final rule. For example, ASTM F3669—24 defines “infant support surface” in a more limited way, by specifying that the infant support surface is necessarily “horizontal.” Thus, the definition included in the final rule is more stringent than the voluntary standard and further reduces the risk of injury associated with nursing pillows. The voluntary standard also defines “caregiver opening” differently than the proposed rule and adds a new definition for “inner wall,” which is not included in the final rule. The voluntary standard’s definition of inner wall implies that it includes any surface of the nursing pillow intended to fit against the caregiver’s torso during use, even if that surface is part of a caregiver attachment. This contradicts the final rule’s definition of caregiver opening, which excludes caregiver attachments.

5. Infant Containment

To reduce the hazards associated with a nursing pillow opening that could be used for lounging or sleeping, the final rule requires nursing pillow openings to be of a size that is more appropriate for an adult user, rather than an infant, and limiting the amount of lateral support for young infants who might be placed within the nursing pillow opening. In case the infant is placed in the opening, this requirement will reduce the potential for an infant’s head to become entrapped in the nursing pillow’s opening or for the product to restrict a young infant’s head movements.

As shown in Figure 3, a 9-inch probe is used to ensure that the product opening is wider than the probe and that the probe can be moved outward from inside the nursing pillow without contacting its surface.

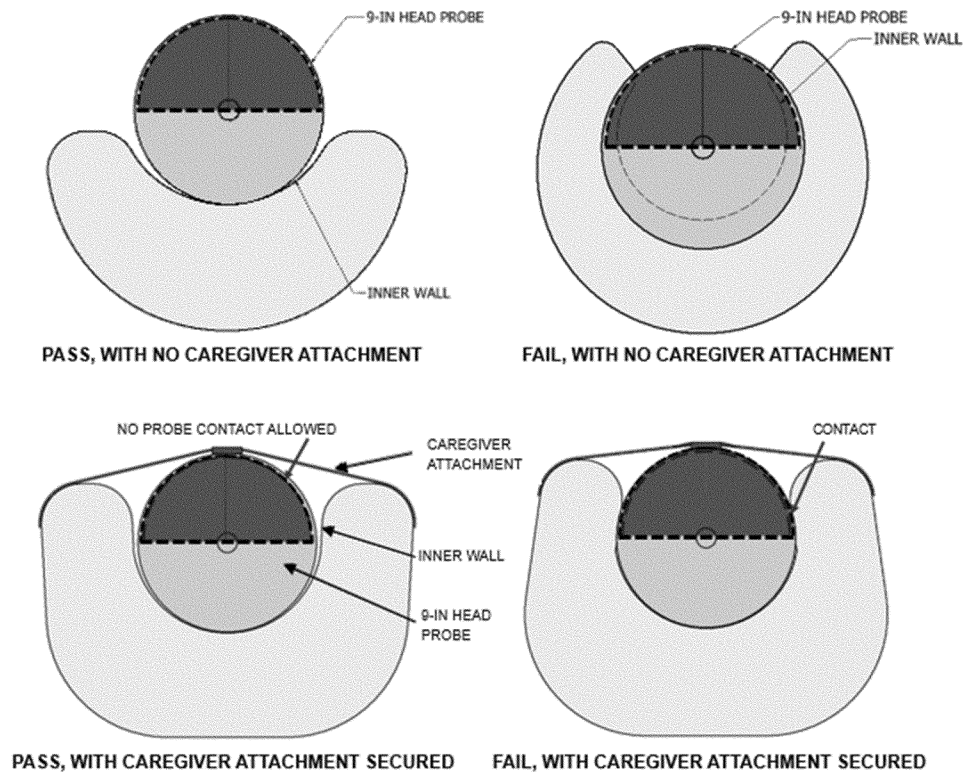

Figure 3: Illustration of nursing pillows with and without a caregiver attachment that pass (left) and fail (right) CPSC's infant containment provision.

If the nursing pillow has a caregiver attachment, during testing the attachment is unlatched, or otherwise unsecured, and moved away from the caregiver opening. To perform the test, the 9-inch probe is placed against the innermost surface of the caregiver opening. The inner wall of the caregiver opening cannot contact the outer half of the probe and the probe must extend beyond a line projected across the outside limits of the caregiver opening. The probe is then slid horizontally out of the caregiver opening, and the outer half of the probe cannot contact the inner wall of the caregiver opening. Contact with a caregiver attachment is not included in these assessments. Then, if the nursing pillow has a caregiver attachment, the caregiver attachment is adjusted to its minimum length and secured, and the same tests are repeated. In the NPR, testing would initially be performed with the caregiver attachment secured and then repeated with the attachment unsecured. However, to allow the product to return

to its original shape, as recommended in public comments, the order of testing is reversed for the final rule. The final rule also includes a revised figure—the one shown in Figure 3—to clarify some of the pass-fail criteria for different nursing pillows. The requirement in the final rule is substantially the same as the Infant Containment requirement (section 6.5) in ASTM F3669—24, although the illustrative figures differ.

E. Warning and Instructional Requirements

As a secondary safety mechanism that provides consumers important information about the hazards associated with nursing pillows and appropriate behaviors to avoid those hazards, the final rule includes requirements for on-product warnings that address the primary hazards associated with nursing pillows, with revisions to address public comments related to warning content and length. The changes include the following:

- Revising the initial sentence from, “USING THIS PRODUCT FOR INFANT

SLEEP OR NAPS CAN KILL,” to, “BABIES HAVE DIED USING NURSING PILLOWS FOR SLEEP OR LOUNGING.”

- Stating explicitly that nursing pillows should be used for feeding only.
- Revising some language for brevity; for example, changing “turn, scoot, or roll over” to “move;” changing “in only a few minutes” to “within minutes;” and changing “Never carry or move product with baby in it” to “Do not use to carry baby.”

- Deleting some statements that communicate redundant messages, for example removing the statements “Use only with an awake baby,” “Keep baby in arm’s reach during use,” and “Keep baby’s face visible and airway clear.”

In addition, the example warning has been reformatted to include a line, or border, to separate the sleep/suffocation-related warning content from the fall-related content.

Figure 5 shows the warning statements and format that would be required on all nursing pillows:

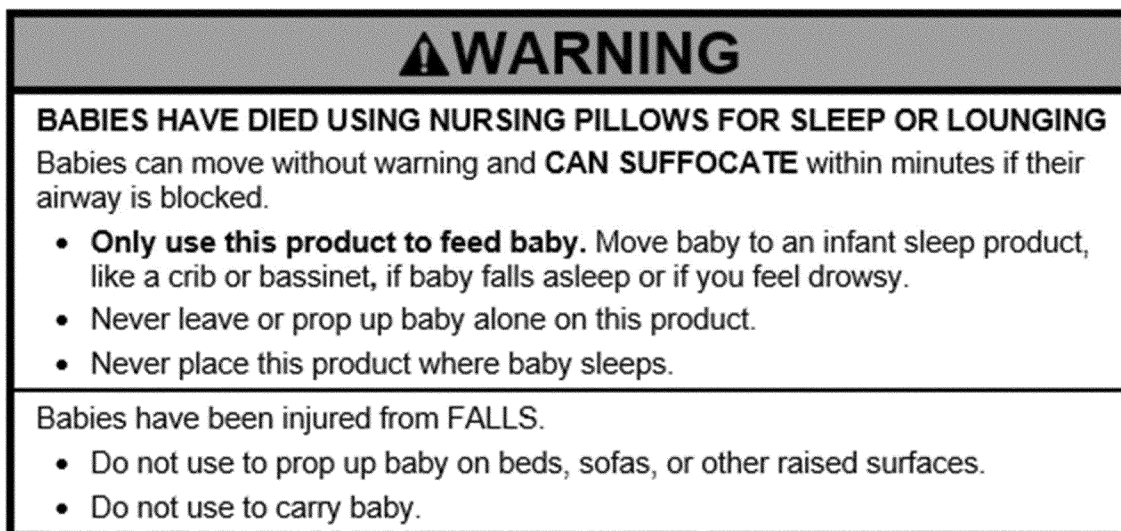

Figure 5: Warning Statement Required on All Nursing Pillows

The warning content and format requirements in the final rule are nearly identical to those in section 8 of ASTM F3669—24. The key difference is that the warning in the final rule includes the statement, “Move baby to an infant sleep product, like a crib or bassinet, if baby falls asleep or if you feel drowsy,” at the end of the first bullet. This statement, which is similar to content in the NPR’s proposed rule warning, is needed (1) to reinforce the safe-sleep message that consumers should move the baby to a product intended for infant, like a crib or bassinet, if the baby falls asleep during or after feeding, and (2) to remind consumers to stop using the product if the consumer feels themselves falling asleep, which is a scenario associated with three infant fatalities. Thus, the warning required in the final rule is more stringent than the voluntary standard and will further reduce the risk of injury associated with the use of nursing pillows.

The final rule also includes a revision to the definition of “conspicuous” to address public comments expressing concerns that the original definition used in the NPR, “visible, when the nursing pillow is in each manufacturer’s recommended use position, to a person while placing an infant into or onto the nursing pillow,” would require multiple identical warning labels on products with multiple infant support surfaces. The final rule defines “conspicuous” to mean “visible to the caregiver while placing the product in the manufacturer’s recommended use position on or against the caregiver’s body.” This definition is substantially the same as the definition included in ASTM F3669—24.

The final rule incorporates by reference the National Electrical Manufacturers Association’s (NEMA’s) ANSI Z535.4–2011(R2017), American National Standard for Product Safety Signs and Labels (ANSI Z535.4–2011), which is the primary U.S. voluntary standard pertaining to the design, application, use, and placement of product safety signs and labels. ANSI Z535.4–2011 includes the following warning format requirements: sections 6.1–6.4, which include requirements related to safety alert symbol use, signal word selection, and warning panel format, arrangement, and shape; sections 7.2–7.6.3, which include color requirements for each panel; and section 8.1, which addresses letter style.

The final rule also incorporates ASTM D3359–23, Standard Test Methods for Rating Adhesion by Tape Test, which covers procedures for assessing the adhesion of relatively ductile coating films to metallic substrates by applying and removing pressure-sensitive tape over cuts made in the film. Many ASTM juvenile product standards use one of the procedures in this standard to assess the permanency of warnings that are applied directly to the surface of a product.

In addition to on-product warnings, the final rule includes basic warning requirements for the packaging that accompanies nursing pillows, largely based on the ASTM Ad Hoc Language task group’s recommended requirements for package warnings. The requirements include warning statements about not using the product for sleep or in sleep products such as cribs, bassinets, or play yards; information about the manufacturer’s recommended weight, height, age, or developmental stage; and

a prohibition against other warnings, statements, or graphics that indicate or imply that an infant can be left in the product without an adult caregiver present. The package warnings also are required to have formatting similar to the on-product warnings. Section 8.6 of ASTM F3669—24 includes the same requirements.

The final rule also includes requirements for the instructional literature to include all on-product warnings and to instruct consumers to read all instructions before using the product, to keep the instructions for future use, and not to use the product if it is damaged or broken. Like the package requirements, the instructions must provide information about the manufacturer’s recommended weight, height, age, or developmental stage, at a minimum. Section 9 of ASTM F3669—24 also includes these instructional literature requirements.

F. Severability

If any requirements in the final rule are stayed or determined to be invalid by a court, the Commission intends that the remaining requirements in the rule will continue in effect and finds that the individual requirements in the rule each independently promote the safety of infants. This applies to all provisions adopted as part of the safety standard for nursing pillows under section 104 of the CPSIA, to reflect the Commission’s intent that part 1242 be given its greatest effect.

VII. Amendment to 16 CFR Part 1112 To Include NOR for Nursing Pillows

The CPSA establishes requirements for product certification and testing. Products subject to a consumer product

safety rule under the CPSA, or to a similar rule, ban, standard, or regulation under any other act enforced by the Commission, must be certified as complying with all applicable CPSC-enforced requirements. 15 U.S.C. 2063(a). Certification of children's products subject to a children's product safety rule must be based on testing conducted by a CPSC-accepted third party conformity assessment body. *Id.* 2063(a)(2). The Commission must publish an NOR for the accreditation of third party conformity assessment bodies to assess conformity with a children's product safety rule to which a children's product is subject. *Id.* 2063(a)(3). The final rule establishing the *Safety Standard for Nursing Pillows*, to be codified as 16 CFR part 1242, is a children's product safety rule that requires the issuance of an NOR.

The Commission published a final rule, *Requirements Pertaining to Third Party Conformity Assessment Bodies*, 78 FR 15836 (March 12, 2013), which is codified at 16 CFR part 1112. Part 1112 became effective on June 10, 2013, and establishes requirements for accreditation of third-party conformity assessment bodies (or laboratories) to test for conformance with a children's product safety rule in accordance with section 14(a)(2) of the CPSA. Part 1112 also lists the NORs that the CPSC has published. 16 CFR 1112.15. All new NORs for new children's product safety rules, such as the nursing pillow standard, require an amendment to part 1112. Accordingly, in the NPR, the Commission proposed to amend part 1112 to add part 1242, *Safety Standard for Nursing Pillows*, in the list of NORs.

Laboratories applying for acceptance as a CPSC-accepted third party conformity assessment body to test to the new standard for nursing pillows are required to meet the third party conformity assessment body accreditation requirements in part 1112. When a laboratory meets the requirements as a CPSC-accepted third party conformity assessment body, the laboratory can apply to the CPSC to have 16 CFR part 1242, *Safety Standard for Nursing Pillows*, included in the laboratory's scope of accreditation of CPSC safety rules listed on the CPSC website at: www.cpsc.gov/labsearch.

VIII. Amendment to Definitions in Product Registration Rule

The statutory definition of "durable infant or toddler product" in section 104(f) applies to all of section 104 of the CPSIA. In addition to requiring the Commission to issue safety standards for durable infant or toddler products, section 104 of the CPSIA also directed

the Commission to issue a rule requiring that manufacturers of durable infant or toddler products establish a program for consumer registration of those products. 15 U.S.C. 2056a(d).

In 2009, the Commission issued a rule implementing the consumer registration requirement. 74 FR 68668 (Dec. 29, 2009) (establishing 16 CFR part 1130). As the CPSIA directs, the consumer registration rule requires each manufacturer of a durable infant or toddler product to provide a postage-paid consumer registration form with each product; keep records of consumers who register their products with the manufacturer; and permanently place the manufacturer's name and certain other identifying information on the product.

When issuing the consumer registration rule, the Commission identified six additional products as durable infant or toddler products: children's folding chairs; changing tables; infant bouncers; infant bathtubs; bed rails; and infant slings. *Id.* at 68669. See 16 CFR 1130.2. The Commission explained that the specified statutory categories were not exclusive, and that the Commission is charged with identifying the product categories that are covered. "Because the statute has a broad definition of a durable infant or toddler product but also includes 12 specific product categories," the Commission noted, "additional items can and should be included in the definition, but should also be specifically listed in the rule." *Id.* at 68669.

In the NPR, the Commission proposed to amend part 1130 to include "Nursing pillows," as defined, as durable infant or toddler products. The Commission proposed to include nursing pillows as a category of "durable infant or toddler product" for purposes of CPSIA section 104 because they: (1) are intended for use, and may be reasonably expected to be used, by children under the age of 5 years; (2) are products similar to the other feeding support products listed in section 104(f)(2), such as high chairs, booster chairs, and hook-on chairs; and (3) are commonly available for resale or "handed down" for use by other children over a period of years. 88 FR 65865, 65877. The Commission received comments on this proposal, which are addressed in section V of this preamble. After considering the comments, the Commission now finalizes the amendment to part 1130 to add "Nursing pillows" to the list of durable infant or toddler products.

IX. Incorporation by Reference

Sections 1242.6(d)(4) and 1242.7(d) of the final rule provide that each nursing pillow must comply with applicable provisions of ANSI Z535.4–11. The Office of the Federal Register (OFR) has regulations concerning incorporation by reference. 1 CFR part 51. For a final rule, agencies must discuss in the preamble to the rule the way in which materials that the agency incorporates by reference are reasonably available to interested persons, and how interested parties can obtain the materials. Additionally, the preamble to the rule must summarize the material. 1 CFR 51.5(b).

In accordance with regulations of the OFR's requirements, section VI of this preamble summarizes ANSI Z535.4–2011 and ASTM D3359–23, which the Commission is incorporating by reference. ANSI Z535.4–2011 and ASTM D3359–23 are copyrighted. Before the effective date of this rule, you can view a copy of these standards at:

- <https://ibr.ansi.org/Standards/nema.aspx> for ANSI Z535.4–2011, and
- https://astm-my.sharepoint.com/:w/g/personal/mpezzella_astm_org/ES8zruHHM5tJmEuwfwl3j3IBLRgSRMUlwHQ?rtm=sUx8dRbu3Eg for ASTM D3359–23.

Once the rule becomes effective, the standards can be viewed free of charge as a read-only document at:

- <https://ibr.ansi.org/Standards/nema.aspx> for ANSI Z535.4–2011, and
- <https://www.astm.org/products-services/reading-room.html> for ASTM D3359–23.

To download or print the standard, interested persons may purchase a copy of the standards from:

- ASTM International (ASTM), 100 Barr Harbor Drive, P.O. Box CB700, West Conshohocken, Pennsylvania 19428–2959; phone: (800) 262–1373; website: www.astm.org for ASTM D3359–23 Standard Test Methods for Rating Adhesion by Tape Test, approved February 1, 2023,
- National Electrical Manufacturers Association (NEMA), 1300 17th St. N, Arlington, VA 22209; phone: (703) 841–3200; website: www.nema.org for ANSI Z535.4–2011(R2017), American National Standard for Product Safety Signs and Labels, ANSI-approved October 20, 2017. This standard is also available from ANSI via its website, <https://www.ansi.org>, or by mail from ANSI, 25 West 43rd Street, 4th Floor, New York, NY 10036, USA, telephone: (212) 642–4900.

Alternatively, interested parties can inspect a copy of the standard at CPSC's Office of the Secretary by contacting Alberta E. Mills, Commission Secretary, U.S. Consumer Product Safety Commission, 4330 East-West Highway, Bethesda, MD 20814; telephone: (301) 504-7479; email: cpsc-os@cpsc.gov.

X. Effective Date

The Administrative Procedure Act (APA) generally requires that the effective date of a rule be at least 30 days after publication of the final rule. 5 U.S.C. 553(d). The Commission proposed an effective date of 180 days after publication of the final rule. Commenters both supported and opposed the 180-day effective date. The AAP, Consumer Reports, and CFA/NCHR supported the 180-day effective date, with two commenters who recommended that CPSC adopt the rule expeditiously, or as early as feasible.

Four comments, from PM&J, LLC; JPMA; the Boppy Company; and BFIDSA, recommend a later effective date of 1 year. The commenters stated that as a result of the rule nursing pillows will need extensive product redesign and will need to meet registration card requirements. They suggested that the additional time is needed to review, understand, and apply the requirements, to design the product to meet the requirements, to perform prototyping and sampling, to perform preproduction testing to ensure compliance, and to perform final random inspections and lab testing, and a shorter timeframe could result in a gap in product availability in the market that would result in people using substitute products.

SAMR noted that Section 1242.1 of the proposed rule specifies an effective date of March 25, 2024, and suggests that CPSC specify at least 6 months after publication of the final rule, rather than a specific date.

The Commission agrees with the comments in support of the 180 day or 6-month effective date to urgently address the hazards associated with nursing pillows. The request to delay the effective date to one year is not supported by any specific information as to why the redesign and testing process for a nursing pillow would require 1 year rather than 6 months. Instead, the justification for 1 year is based on the precedent of the registration card rule published in 2009. Some products on the market already meet most of the requirements in the final rule, as discussed in the NPR briefing package,²⁵ and the testing

process is relatively simple and can be completed using minimal equipment by the testing labs. The commenter who stated that manufacturers need "additional time" to develop compliant products did not provide any details as to why 6 months would not be sufficient. That commenter specifically mentions that it could take a full month for final product inspections and testing to the new rule, but that does not explain why 6 months is not sufficient to comply.

The comments also do not provide any specifics as to the extent to which the effort required is more or less than the 200 hours of labor estimated in the NPR. For one person working alone, 200 hours represents 5 weeks of full-time effort. Comments do not provide any specific data as to why the level of effort to redesign and distribute a nursing pillow would require 1 year to complete. Delaying the rule by an additional 6 months would delay the benefits of hazard reduction by 6 months, therefore, the Commission does not adopt a later effective date.

The portion of the proposed rule stating that the effective date of the rule is March 25, 2024, was in error. The commenter expressing concern about this date is correct that the final rule should specify an effective date of 6 months after publication of the final rule, rather than a date before the final rule is even published.

After considering the comments, the Commission now finalizes the rule with a 180-day effective date, because this amount of time is typical for rules issued under section 104 of the CPSIA and commenters have not justified a different period. Six months is also the period that JPMA typically allows for products in their certification program to shift to a new standard once that new standard is published. Therefore, juvenile product manufacturers are accustomed to adjusting to new standards within this time. A 180-day effective date should also be sufficient for manufacturers to comply with this rule because the requirements do not demand significant preparation by testing laboratories. For example, no new complex testing instruments or devices would be required to test nursing pillows for compliance with the final rule.

XI. Regulatory Flexibility Act

The Regulatory Flexibility Act (RFA); 5 U.S.C. 601–612, requires that agencies review a proposed rule's potential economic impact on small U.S. entities, including small businesses. Section 604 of the RFA generally requires that agencies make a final regulatory

flexibility analysis (FRFA) available when a final rule is published. A FRFA must describe the impact of the rule on small entities and identify significant alternatives that accomplish the statutory objectives and minimize any significant economic impact of the proposed rule on small entities. It must also describe issues raised by public comments, and by the U.S. Small Business Administration's Office of Advocacy (SBA's Office of Advocacy) on the Initial Regulatory Flexibility Analysis (IRFA) that was prepared for the proposed rule and any changes to the final rule made in response to those comments. CPSC staff prepared an IRFA for this rulemaking that was included in the NPR and the staff's briefing package to the Commission for the NPR.²⁶ For the final rule, an FRFA is provided below.

A. Need for and Objectives of This Rule

The objective of the final rule is to reduce the risk of injury and death associated with nursing pillows. A detailed analysis of the objectives and statutory basis for the rule is set forth in section I of the preamble. As discussed in sections VI, VII, and VIII of this preamble, the rule sets mandatory requirements for nursing pillows to address the suffocation, entrapment, and fall hazards associated with these products, adds nursing pillows to the list of products for which a registration card is required, and adds nursing pillows to the list of durable infant products for which a NOR is required.

B. Issues Raised by Public Comments Concerning Impact on Small Entities; Changes in Response to Those Comments

Comments from the SBA's Office of Advocacy and Unrattled, LLC addressed small business impacts. A small business, Unrattled, LLC, commented that the amount of time and money associated with redesigning, remanufacturing, and relaunching could cause them to go out of business. The commenter did not provide any data to support this assertion. The comment requested a "6 months or more" timeframe for compliance. The NPR included and the final rule provides 180 days or 6 months for compliance. The other comment was from the SBA's Office of Advocacy and this comment is addressed below. There were no other public comments in response to the IRFA.

²⁵ See Staff's NPR Briefing Package at Tab B.

²⁶ See Staff's NPR Briefing Package at Tab E.

C. Issues Raised by the Staff of the Small Business Administration's Chief Counsel for the Office of Advocacy; Changes in Response to Those Comments

The SBA's Office of Advocacy did not file public comments but shared small business concerns with CPSC that the safety standard will drastically increase the cost of labor, materials, and testing associated with nursing pillows.²⁷ This is consistent with the analysis in the IRFA that the burden would be significant for a substantial number of small entities. SBA's Office of Advocacy provided specific estimates that the use of firmer pillow filling would cost 22 to 30 percent more than a baseline, and that newly designed products would require 38 percent more fabric. SBA's Office of Advocacy also estimated that sewing the new designs would be more difficult, increasing labor costs by 10 to 15 percent. The Commission is not making any changes to burden estimates based on this input because SBA Advocacy did not provide data for their specific estimates, denying CPSC the opportunity to validate these claims. The final rule is a performance-based standard, not a design standard. Moreover, SBA's Office of Advocacy did not provide a source for their estimates, did not include a specific amount of estimated burden, and did not include a baseline for their estimates of increased percentages.

SBA's Office of Advocacy also commented that the cost of the rule should be annualized over a ten-year period that is discounted at 7 percent. CPSC, however, is not obligated by the RFA to provide such a calculation for the cost of a rule, and does not do so for this rule, where, consistent with SBA Office of Advocacy's fundamental position, CPSC has independently concluded that this rule would have a significant impact to a substantial number of small businesses.

In addition, SBA's Office of Advocacy suggested the regulatory alternatives of requiring only a warning label with no performance requirements and delaying implementation of the final rule to reduce the burden on small entities. The IRFA for the NPR discussed delaying implementation to wait for the ASTM standard. The specific alternatives recommended by SBA's Office of Advocacy are considered below, in section XII, G.

²⁷ CPSC received comments from SBA's Office of Advocacy via email; they are included on the public docket for the NPR: <https://www.regulations.gov/comment/CPSC-2023-0037-0428>.

D. Small Entities To Which the Rule Would Apply

Small entities subject to this rule include small businesses that supply nursing pillows to the U.S. market, which includes manufacturers and importers. The SBA size standard for what constitutes a "small" business is typically 500 to 750 employees, depending on the North American Industry Classification Series (NAICS) category.²⁸ Manufacturers and importers of nursing pillows may fall into a diverse range of NAICS categories, depending on their primary line of business, which is typically in a broader category of children's products or other consumer goods.

CPSC staff identified 22 small U.S. manufacturers that design nursing pillows in the U.S. and ship from a U.S. address, although production may be in a foreign country.²⁹ In addition, staff identified six small U.S. importers³⁰ that do not appear to have U.S. design staff but do ship from a U.S. address. Staff also identified more than 500 U.S. small crafters that ship from the United States.

The final rule clarifies that slipcovers sold on or together with the nursing pillow are subject to the requirements of the safety standard. Manufacturers of nursing pillows and the nursing pillow covers they sell with their nursing pillows are the same entities that were included in the IRFA of the NPR and are included in this FRFA for the final rule.

The final rule does not apply to manufacturers or suppliers of aftermarket nursing pillow covers by a third-party manufacturer (*i.e.*, not the nursing pillow manufacturer). There could be an indirect impact on these companies if nursing pillow manufacturers change the size or shape of nursing pillows to comply with the rule and thereby require changes to aftermarket slipcover designs. There are

²⁸ The size standards are based on the number of employees or the annual revenue of the firm, and there is a specific size standard for each 6-digit North American Industry Classification Series (NAICS) category. The North American Industry Classification System (NAICS) is the standard used by Federal statistical agencies in classifying business establishments for the purpose of collecting, analyzing, and publishing statistical data related to the U.S. business economy. For more information, see <https://www.census.gov/naics/>. Some programs use 6-digit NAICS codes, which provide more specific information than programs that use more general 3- or 4-digit NAICS codes.

²⁹ Based on staff's assessment of prominent online and brick and mortar retail stores for nursing pillows in the Spring of 2023.

³⁰ See, in 13 CFR 121.103, SBA's regulations for considering foreign and domestic affiliated companies in determining the size standard that applies to a particular company. The determinations differ by program and corporate structure.

hundreds of these suppliers, the majority of which are small businesses.

The final rule also does not apply to any small U.S. retailers. As specified in 16 CFR part 1109, retailers may rely on a certificate of compliance provided by their suppliers.

E. Compliance, Reporting, Paperwork, and Recordkeeping Requirements of the Rule

Suppliers will be required to meet the performance, warning label, consumer registration card, and user instruction requirements of the rule, and conduct third-party testing to demonstrate compliance. A detailed discussion of mandatory requirements is set forth in section VII of the preamble. Section III of this preamble describes the products subject to this final rule.

1. Costs Associated With Modifying Products

Most of the nursing pillows on the market will require modification, which will result in most of the costs to be incurred in the first year as a result of redesigning the product to meet the requirements in the final rule. With an estimated 1,000 models to be redesigned across all firms who sell to the U.S., the total cost of redesign to the industry in the first year could be as high as \$15 million. This cost is slightly higher than the estimate in the IRFA because the labor rates have been updated to reflect the most current Bureau of Labor Statistics (BLS) data.

The effort required for a one-time redesign is estimated to require 200 hours of professional staff (*i.e.*, designers and testers) time per model, including in-house testing of the prototypes and development of labels, customer registration forms, and instruction materials. Using the BLS Employer Costs of Employee Compensation as of March 2024,³¹ the estimated cost per model is \$13,648, at a current cost for professional labor of \$68.24 per hour, rounded for the purpose of analysis to \$14,000 per model. Materials costs for prototyping are estimated to be minimal, likely under \$1,000, given that nursing pillows typically are made of fabric and stuffing materials. Therefore, the total cost of redesign, including redesigning slipcovers, is approximately \$15,000 per model (\$14,000 for labor and \$1,000 for materials).

Although some manufacturers may offer a wide selection of fabric

³¹ https://www.bls.gov/news.release/archives/ecec_06182024.htm. Table 2. Total Compensation for "Professional and related." These costs reflect the employers' cost for salaries, wages, and benefits for civilian workers.

coverings, most manufacturers offer three or fewer physically different models with different dimensions or features that might impact compliance. Thus, the high-end cost estimate of redesign per manufacturer is, based on three different models, \$45,000. In most cases, particularly for small companies, the cost is likely less because most companies usually have one or at most two physically distinct models. Manufacturers that sell into the U.S. market have mostly outsourced production to foreign countries, but generally still design their products in North America. Therefore, the estimate for the cost of redesign reflects U.S. labor and materials costs for prototype designs.³² In addition, even though importers do not directly pay for the cost of redesign, the cost of redesign is likely reflected in the wholesale price.

The clarification in the final rule that slipcovers sold on or together with the nursing pillow are within the scope of the rule does not change or add to the burden estimate per company or the number of small entities impacted by the rule, because the impact on these entities for these requirements, as noted above, was included in the NPR and the final rule.

Changes to labeling and instructions will be necessary on nursing pillows, including their slipcovers. Generally, costs associated with marking and labeling, as well as providing instructional materials, are low on a per-unit basis. The final rule provides the text and graphics for the required labels and instructions. Therefore, specialized expertise in graphic design will not be required to develop the warnings and instructions.

The reporting and recordkeeping requirements in this rule will be new for all suppliers. The labeling and instruction requirements constitute a “paperwork” burden under the Paperwork Reduction Act (PRA). See section XIII for a detailed discussion. The ongoing cost of the new labels, registration forms, and instruction manuals is estimated at about \$1 per item for materials. The initial cost for labor of developing the labels and instruction manuals is included in the

cost of redesigning models to comply with this rule. CPSC’s Office of the Small Business Ombudsman provides additional online resources for small businesses to assist with the recordkeeping requirements.³³

Suppliers must also provide product registration cards. CPSC’s public website provides instructions and examples for how to develop the certificates of compliance and product registration cards.³⁴

2. Third-Party Testing Costs

The final rule will require all manufacturers and importers of nursing pillows to meet additional third-party testing requirements under section 14 of the CPSA. As specified in 16 CFR part 1109, entities that are not manufacturers of children’s products, such as importers and wholesalers, may rely on the certificate of compliance provided by others. It is reasonable to anticipate that while foreign manufacturers may bear most of the initial cost of testing, due to the prevalence of overseas manufacturing for this product sector, those manufacturers would pass on at least some of the cost of testing for compliance to U.S.-based importers and wholesalers.

Third-party testing costs for nursing pillows under the final rule are estimated at \$500 to \$1,000 per model. The annual cost of samples for testing is estimated at around \$150, bringing the overall annual cost to an estimated \$650 to \$1,150 per model. However, some small-volume suppliers would likely be able to raise retail prices to cover at least some of their testing costs. For example, a crafter selling 200 nursing pillows a year could cover the entire testing cost by raising the price by \$3.25.

3. Summary of Impacts

Generally, based on SBA’s Office of Advocacy’s guidelines, CPSC considers impacts that exceed 1 percent of a firm’s revenue to be potentially significant. Staff determined that an average of \$45,000 is a conservative estimate of the redesign cost per manufacturer. Therefore, any firms with revenue less than \$4.5 million in revenue (about 90,000 units at an average price of \$50 per unit) could incur a significant impact, because their redesign costs

could exceed 1 percent of their revenue. For small firms with just one product, the redesign cost would be \$15,000, and their revenue threshold would be \$1.5 million. Staff estimates that 14 U.S. firms exceed the threshold and therefore the rule would not have a significant impact: nine of these firms offer their products in brick and mortar stores, and five sell their products online only. Of these 14 firms, nine are small U.S. businesses. There are, however, more than 1,000 suppliers to the U.S. market—with annual sales for the whole industry estimated at 1.34 million units—nearly all of which fall below the threshold of 90,000 units sold per year. For this reason, the costs of redesign are likely to be significant for a substantial number of small firms, particularly small home crafters.³⁵

Firms may be able to reduce the impact of the redesign costs by raising the retail price of nursing pillows by a few dollars, which may reduce the impact of the rule for small businesses. Since warning labels, registration forms, and instruction manuals could add up to \$1 to the cost of the product, firms may decide to pass this on to the consumer. In addition, if companies decide to pass the ongoing cost of testing onto consumers, the additional retail price increase of perhaps \$1, added to the additional \$1 cost of the warning labels and instruction manuals, would total \$2, or 4 percent of the price of a \$50 item. The overall market for nursing pillows is relatively inelastic, meaning that an increase or decrease in price will not have a proportional increase or decrease in demand, because many parents perceive a nursing pillow as a necessity and are therefore likely willing to pay an increased price.

As noted above, the retail price increase to cover redesign costs could be relatively minor, even for relatively small-volume suppliers. For example, a firm supplying 5,000 nursing pillows per year could cover the entire cost of redesign by raising the price by \$3. Small-volume hand crafters, however, may not have enough sales to cover the expense of redesign and testing, while small-volume importers may not be able to find compliant suppliers. But again, even relatively small-volume suppliers may be able to reduce the impact of the rule by raising prices to cover costs of testing and redesign. A retail price increase of less than \$5 could cover all the testing costs and a substantial

³² See the following: The Pros and Cons of Outsourcing: A Look at American Clothing Manufacturers | by clothing manufacturers | Medium; Outsourcing Manufacturing in the Fashion Industry: Pros & Cons for Small Businesses—ApparelMagic; Outsourcing Clothing Manufacturing: Challenges and Solutions Strategy—Uphance, available at: <https://usaclthingmanufacturers.medium.com/the-pros-and-cons-of-outsourcing-a-look-at-american-clothing-manufacturers-8a772b00302c> and <https://www.uphance.com/blog/outsourcing-fashion-manufacturing/>.

³³ For instance, see: <https://www.cpsc.gov/Business-Manufacturing/Small-Business-Resources>.

³⁴ For instance, see: <https://www.cpsc.gov/Business-Manufacturing/Testing-Certification/Childrens-Product-Certificate> and <https://www.cpsc.gov/Business-Manufacturing/Business-Education/Durable-Infant-or-Toddler-Products/FAQs-Durable-Infant-or-Toddler-Product-Consumer-Registration>.

³⁵ Several hundred foreign direct shippers, including small home crafter businesses, will also likely be impacted, but the RFA requires analysis of the impact on U.S. small businesses.

portion of the redesign costs, even for a very small supplier.

Since most nursing pillows will need to be redesigned, as described above, large businesses may also have to raise their prices to cover compliance costs, which means that small businesses would not necessarily be less competitive if they also had to raise their prices to cover compliance costs. Some public commenters stated that the current nursing pillow market will not be able to support any retail price increases; however, the commenters did not provide any data to support this assertion.

In addition, the best-selling nursing pillows are from companies, including small U.S. companies, that have sufficient sales volume to spread the cost of compliance over thousands of units and are unlikely to exit the market. It is likely that the products currently in stores, and the best-selling online-only products, would still be available, with modest redesigns.

Consumers may not experience a significant loss of consumer utility as some small-volume sellers exit online marketplaces, since the selection in brick-and-mortar stores is already limited to the products of only nine companies. Also, many of the best-selling products online are from the same group of firms that sell in stores, which include small businesses. It is likely that the products currently in stores, and the best-selling online-only products, will still be available, with modest redesigns. However, there may be some loss in sales of specific products because of the requirements of the final rule, if the redesigned products are less appealing to consumers.

F. Other Federal Rules That May Duplicate, Overlap, or Conflict With the Final Rule

CPSC has not identified any other federal rules that duplicate, overlap, or conflict with the final rule.

G. Alternatives Considered To Reduce the Impact on Small Entities

The Commission considered the following alternatives to minimize the significant economic impact on small businesses.

1. Not Establishing a Safety Standard

The Commission considered not establishing a safety standard for nursing pillows. Although this alternative would result in no regulatory impact on small businesses, deaths and injuries from the use of nursing pillows would likely continue to occur at similar rates as those observed between 2010 and 2022. Therefore, the

Commission is issuing a final rule to establish a safety standard for nursing pillows to reduce the likelihood of injuries and deaths from the use of nursing pillows, as required by CPSIA section 104.

2. Different Effective Date

The Commission is establishing a 180-day effective date after publication of the final rule in the **Federal Register** for the reasons discussed in section X. In the NPR, the Commission rejected adopting an effective date earlier than 180 days because of concerns that it would have increased the burden on small businesses and could have resulted in temporary shortages of nursing pillows due to testing laboratory capabilities.

Some public comments on the NPR requested a later effective date of one year to allow suppliers more time to comply, to redesign and to ship the product. The commenters, however, did not provide any specific data (such as amount of labor needed for redesign or current shipping times from foreign manufacturers) on why it would take more than 6 months to redesign and distribute a pillow. Other public comments received recommended effective dates of 180 days or 6 months as proposed in the NPR. Therefore, the Commission does not have a basis to delay implementation of the rule beyond 6 months, especially inasmuch it could result in additional injuries and deaths.

3. “Angular” Performance Requirement

In the NPR, the Commission requested comments on whether to include an “angular” performance requirement in the safety standard for nursing pillows, discussed above in section V. Some commenters supported this requirement; however, none provided specific data to support such a requirement. SBA’s Office of Advocacy commented that this alternative might increase the burden on small businesses, without effectively reducing the hazard and agreed with the Commission’s preliminary decision to not include the requirement in the NPR. As discussed above, the Commission is not including such a requirement in the final rule, thereby eliminating a potential burden on small businesses.

4. Warning Label Requirement Only

In response to comments by SBA’s Office of Advocacy and a consumer, the Commission considered the impact of only requiring warning labels in the safety standard of nursing pillows. Warning about hazards is less effective at eliminating or reducing exposure to

hazards than either designing the hazard out of a product or guarding the consumer from the hazard; therefore, the use of warnings is lower in the hazard control hierarchy than the other two approaches.³⁶ This alternative would reduce the burden on small entities. However, because it would also reduce benefits of the regulation leading to additional deaths of infants, the Commission is not adopting the alternative to only require warning labels.

H. Impact on Testing Labs

Section 14 of the CPSA requires that all products that are subject to a children’s product safety rule must be tested by a third-party conformity assessment body that has been accredited by CPSC. One of the roles of these third-party conformity assessment bodies is to test products for compliance with applicable children’s product safety rules. Testing laboratories that want to conduct testing must meet the NOR for third-party conformity testing. See 16 CFR part 1112.

The Commission does not expect a significant adverse impact on any testing laboratories as a result of this rule. Laboratories will not need to acquire complex or costly testing instruments or devices to test nursing pillows for compliance, and laboratories will decide for themselves whether to offer testing services for nursing pillow compliance.

XII. Environmental Considerations

Certain categories of CPSC actions normally have “little or no potential for affecting the human environment” and therefore do not require an environmental assessment or an environmental impact statement. Safety standards providing requirements for consumer products come under this categorical exclusion. 16 CFR 1021.5(c)(1). The final rule for nursing pillows falls within the categorical exclusion.

XIII. Paperwork Reduction Act

This final rule for nursing pillows contains information collection requirements that are subject to public comment and review by the Office of Management and Budget (OMB) under the Paperwork Reduction Act of 1995 (PRA; 44 U.S.C. 3501–3521). In this document, pursuant to 44 U.S.C. 3507(a)(1)(D), we set forth:

- Title for the collection of information;
- Summary of the collection of information;

³⁶ See Staff’s NPR Briefing Package at Tab C.

- Brief description of the need for the information and the proposed use of the information;
 - Description of the likely respondents and proposed frequency of response to the collection of information;
 - Estimate of the burden that shall result from the collection of information; and
 - Notice that comments may be submitted to the OMB.
- The preamble to the NPR discussed the information collection burden of the proposed rule and specifically requested

comments on the accuracy of our estimates. 85 FR 67927–28. The OMB assigned control number 3041–0197 for this information collection. CPSC did not receive any comment regarding the information collection burden of the proposal in the NPR. In accordance with PRA requirements, the Commission provides the following information:

Title: Safety Standard for Nursing Pillows.

Description: The final rule requires each nursing pillow within the scope of the rule to meet the rule’s new

performance and labeling requirements. It also requires suppliers to conduct third party testing to demonstrate compliance and provide the specified warning label and instructions. These requirements fall within the definition of a “collection of information,” as defined in 44 U.S.C. 3502(3).

Description of Respondents: Persons who manufacture or import nursing pillows.

Estimated Burden: We estimate the burden of this collection of information as follows:

TABLE 7—ESTIMATED ANNUAL REPORTING BURDEN

Burden type	Number of respondents	Frequency of responses	Total annual responses	Hours per response	Total burden hours
Labeling and instructions	844	1	844	2	1,688

While some products currently have labels, all products would have to meet the specific labeling requirements and instructions specified in the rule, which provides the text and graphics for the required labels and instructions. Specialized expertise in graphics design would not be required to develop the warnings and instructions. Most reporting and recordkeeping requirements in this rule would be new for all suppliers.

CPSC estimates there are 844 entities that would respond to this collection annually.³⁷ We estimate that the time required to create and modify labeling and instructions is about 2 hours per response. Therefore, the estimated burden associated with this collection is 844 responses × 1 response per year × 2 hours per response = 1,688 hours annually.

We estimate the hourly compensation for the time required to respond to the collection is \$41.76.³⁸ Therefore, the estimated annual labor cost of the collection is \$70,491 (\$41.76 per hour × 1,688 hours = \$70,490.88). Based on this analysis, the mandatory safety standard for nursing pillows will impose an additional burden to industry of 1,688 hours at a total cost of \$70,491. In compliance with the Paperwork Reduction Act of 1995 (44 U.S.C.

3507(d)), CPSC has submitted the information collection requirements of this final rule to the OMB.

XIV. Preemption

Section 26(a) of the CPSA, 15 U.S.C. 2075(a), provides that when a consumer product safety standard is in effect and applies to a product, no state or political subdivision of a state may either establish or continue in effect a standard or regulation that prescribes requirements for the performance, composition, contents, design, finish, construction, packaging, or labeling of such product dealing with the same risk of injury unless the state requirement is identical to the federal standard. Section 26(c) of the CPSA also provides that states or political subdivisions of states may apply to the Commission for an exemption from this preemption under certain circumstances. Section 104(b) of the CPSIA refers to the rules to be issued under that section as “consumer product safety standards.” Therefore, once this final rule is issued, the rule will preempt state laws in accordance with section 26(a) of the CPSA.

XV. Congressional Review Act

The Congressional Review Act (CRA; 5 U.S.C. 801–808) states that, before a rule may take effect, the agency issuing the rule must submit the rule, and certain related information, to each House of Congress and the Comptroller General. 5 U.S.C. 801(a)(1). The submission must indicate whether the rule is a “major rule.” The CRA states that the Office of Information and Regulatory Affairs (OIRA) determines whether a rule qualifies as a “major rule.” Pursuant to the CRA, OIRA designated this rule as not a “major

rule,” as defined in 5 U.S.C. 804(2). To comply with the CRA, CPSC will submit the required information to each House of Congress and the Comptroller General.

XVI. References

Daniel A. Johnson, *Practical Aspects of Graphics Related to Safety Instructions and Warnings*, in *Handbook of Warnings* 463–476 (Michael S. Wogalter ed., 2006).

Michael J. Kalsher et al., *Reconsidering the Role of Design Standards in Developing Effective Safety Labeling: Monolithic Recipes or Collections of Separable Features?*, 61(6) *Human Factors*, 920–952 (2019).

Kenneth R. Laughery, Sr. & Danielle Paige Smith, *Explicit Information in Warnings*, in *Handbook of Warnings* 419–428 (Michael S. Wogalter ed., 2006).

Mary F. Lesch, *Consumer Product Warnings: Research and Recommendations*, in *Handbook of Warnings* 137–146 (Michael S. Wogalter ed., 2006).

Erin M. Mannen, U.S. Consumer Prod. Safety Comm’n, *Pillows Product Characterization and Testing* (2022). Available: <https://www.cpsc.gov/content/Pillows-Product-Characterization-and-Testing>.

Donna M. Riley, *Beliefs, Attitudes, and Motivation*, in *Handbook of warnings* 289–300 (Michael S. Wogalter ed., 2006).

Melanie B. Tannenbaum et al., *Appealing to Fear: A meta-analysis of fear appeal effectiveness and theories*, 141(6) *Psychological Bulletin*, 1178–1204 (2015).

Michael S. Wogalter & N. Clayton Silver, *Warning signal words: Connoted strength and understandability by children, elders, and non-native English speakers*, 38(11) *Ergonomics*, 2188–2206 (1995).

Michael S. Wogalter et al., *Warning Symbols*, in *Handbook of Warnings* 159–176 (Michael S. Wogalter ed., 2006).

³⁷ Although the total number of nursing pillow suppliers to the United States is estimated to be more than 1,000, only a portion of those suppliers will respond to the collection each year based on when they introduce new product models or redesign previous models.

³⁸ U.S. Bureau of Labor Statistics, “Employer Costs for Employee Compensation,” March 2024, Table 4, total compensation for all sales and office workers in goods-producing private industries: https://www.bls.gov/news.release/archives/eccec_06182024.htm.

Michael S. Wogalter, *Attention Switch and Maintenance*, in Handbook of Warnings 245–265 (Michael S. Wogalter ed., 2006).

List of Subjects

16 CFR Part 1112

Administrative practice and procedure, Audit, Consumer protection, Reporting and recordkeeping requirements, Third party conformity assessment body.

16 CFR Part 1130

Administrative practice and procedure, Business and industry, Consumer protection, Reporting and recordkeeping requirements.

16 CFR Part 1242

Consumer protection, Imports, Incorporation by reference, Infants and children, Labeling, Law enforcement, Nursing, Pillows, and Toys.

For the reasons discussed in the preamble, the Commission proposes to amend title 16, chapter II, of the Code of Federal Regulations as follows:

PART 1112—REQUIREMENTS PERTAINING TO THIRD PARTY CONFORMITY ASSESSMENT BODIES

■ 1. The authority citation for part 1112 continues to read as follows:

Authority: 15 U.S.C. 2063.

■ 2. Amend § 1112.15 by adding paragraph (b)(56) to read as follows:

§ 1112.15 When can a third party conformity assessment body apply for CPSC acceptance for a particular CPSC rule and/or test method?

* * * * *

(b) * * * (56) 16 CFR part 1242, Safety Standard for Nursing Pillows.

* * * * *

PART 1130—REQUIREMENTS FOR CONSUMER REGISTRATION OF DURABLE INFANT OR TODDLER PRODUCTS

■ 3. The authority citation for part 1130 continues to read as follows:

Authority: 15 U.S.C. 2056a(d), 2065(b).

■ 4. Amend § 1130.2 by:

■ a. Removing the semicolons at the ends of paragraphs (a)(1) through (16) and adding periods in their place;

■ b. Removing “; and” at the end of paragraph (a)(17) and adding a period in its place; and

■ c. Adding paragraph (a)(19).

The addition reads as follows:

§ 1130.2 Definitions.

* * * * *

(a) * * *

(19) Nursing pillows.

* * * * *

■ 5. Add part 1242 to read as follows:

PART 1242—SAFETY STANDARD FOR NURSING PILLOWS

Sec.

1242.1 Scope, purpose, application, and exemptions.

1242.2 Definitions.

1242.3 General requirements.

1242.4 Performance requirements.

1242.5 Test methods.

1242.6 Marking and labeling.

1242.7 Instructional literature.

1242.8 Incorporation by reference.

1242.9 Severability.

Authority: 15 U.S.C. 2056a

§ 1242.1 Scope, purpose, application, and exemptions.

(a) Scope and purpose. This part, a consumer product safety standard, prescribes requirements intended to reduce the risk of death and injury from hazards associated with nursing pillows, as defined in § 1242.2.

(b) Application. Except as provided in paragraph (c) of this section, all nursing pillows that are manufactured after April 23, 2025, are subject to the requirements of this part.

(c) Exemptions. The following products are exempt from this part:

(1) Maternity pillows, as defined in § 1242.2,

(2) Sling carriers, as defined in 16 CFR part 1228, and

(3) Soft infant and toddler carriers, as defined in 16 CFR part 1226.

§ 1242.2 Definitions.

Caregiver attachment means a portion of the product that is not an infant support surface and is intended to secure the nursing pillow to the caregiver. A caregiver attachment may comprise components including, but not limited to, straps, buckles, or latches.

Caregiver opening means the surface of the nursing pillow, excluding the caregiver attachment, intended to fit against the caregiver’s torso during use. This surface is typically, but not necessarily, crescent-like in shape.

Conspicuous means visible to the caregiver while placing the product in the manufacturer’s recommended use position on or against the caregiver’s body.

Infant restraint system means a portion of a product intended to secure or hold an infant in place on the product. These typically take the form of straps or harnesses that are secured by the caregiver.

Infant support surface means the manufacturer’s intended support surface for the infant during nursing or feeding.

Maternity pillow, also known as a pregnancy pillow, means a large body pillow intended, marketed, and designed to provide support to a pregnant adult’s body during sleep or while lying down.

Nursing pillow means any product intended, marketed, or designed to position and support an infant close to a caregiver’s body while breastfeeding or bottle feeding, including any removable covers, or slipcovers, sold on or together with such a product. These products rest upon, wrap around, or are worn by a caregiver in a seated or reclined position.

Safety alert symbol means a symbol consisting of an exclamation mark surrounded by an equilateral triangle, or an equilateral triangle with a contrasting superimposed exclamation mark. The safety alert symbol precedes the signal word “WARNING,” or other signal word, in the signal word panel of a warning.

§ 1242.3 General requirements.

(a) Lead in paints. All paint and surface coatings on the product shall comply with the requirements of 16 CFR part 1303.

(b) Small parts. There shall be no small parts, as determined by 16 CFR part 1501, before testing or liberated as a result of testing.

(c) Hazardous sharp edges or points. There shall be no hazardous sharp points or edges, as determined by 16 CFR 1500.48 and 1500.49, before or after testing.

(d) Removal of components. When tested in accordance with § 1242.5(b), any removal of components that are accessible to an infant while in the product or from any position around the product shall not present a small part, sharp point, or sharp edge as required in paragraphs (b) and (c) of this section.

(e) Permanency of labels and warnings. (1) Warning labels (whether paper or non-paper) shall be permanent when tested in accordance with § 1242.5(c)(1) through (3).

(2) Warning statements applied directly onto the surface of the product by hot stamping, heat transfer, printing, wood burning, etc. shall be permanent when tested in accordance with § 1242.5(c)(4).

(3) Non-paper labels shall not liberate small parts when tested in accordance with § 1242.5(c)(5).

(4) Warning labels that are attached to the fabric of nursing pillows with seams shall remain in contact with the fabric around the entire perimeter of the label, when the product is in all manufacturer-recommended use positions, when tested in accordance with § 1242.5(c)(3).

§ 1242.4 Performance requirements.

(a) *Firmness.* When tested in accordance with § 1242.5(d), (e) and (f), the force required for a 1.00-in. (2.54

cm) displacement of the 3-inch (76.2 mm) diameter hemispheric probe (figure 1 to this paragraph (a)—3-in. head

probe) at any measurement location shall be greater than 10.0 N (2.24 lb).

Figure 1 to Paragraph (a)—3-in Head Probe

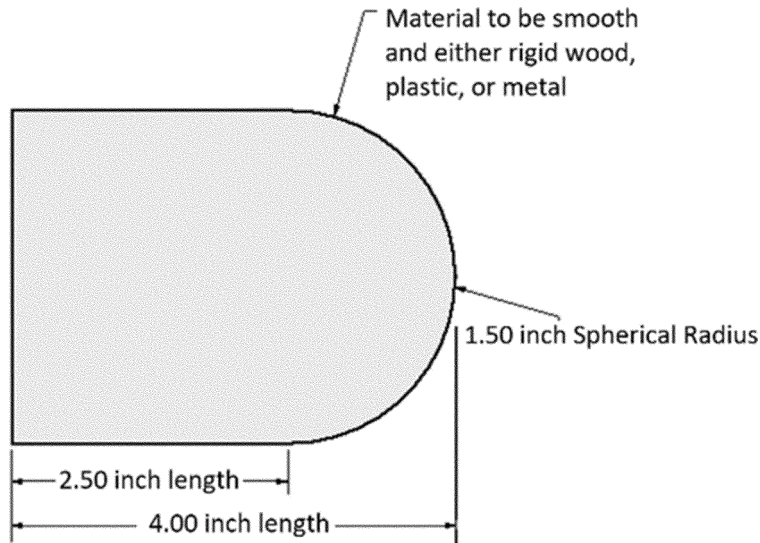

(b) *Infant containment.* When tested in accordance with § 1242.5(g), the surfaces within the caregiver opening of the product shall not contact the 9-inch (230 mm) diameter head probe (figure 2

to this paragraph (b)—9-in. head probe) such that the probe is constrained within the caregiver opening and, when placed according to § 1242.5(g)(6), the

probe must extend past the caregiver opening.

Figure 2 to Paragraph (b)—9-in. Head Probe

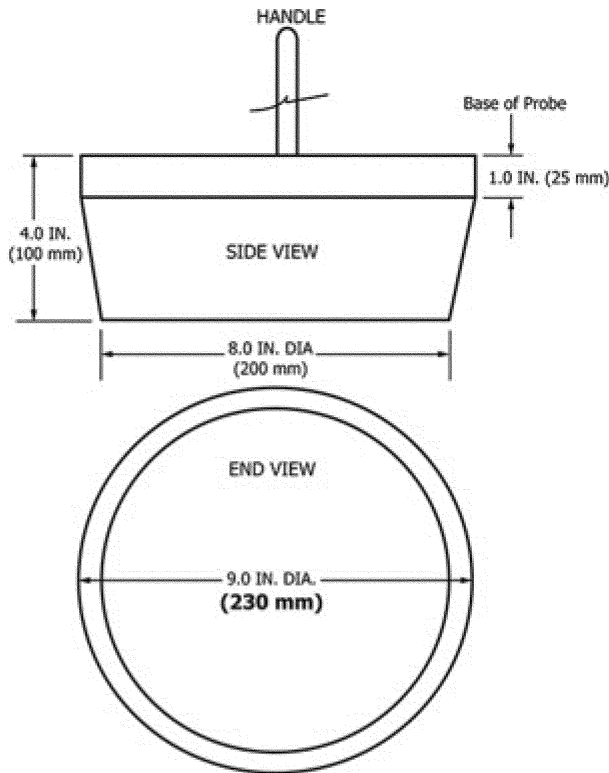

(c) *Infant restraints.* Nursing pillows shall not include any infant restraint system.

(d) *Seam strength.* When tested in accordance with § 1242.5(h), fabric/mesh seams and points of attachment shall not fail such that a small part, sharp point, or sharp edge is presented, as required in § 1242.3(b) and (c).

(e) *Caregiver attachment strength.* When tested in accordance with § 1242.5(i), material seams, points of attachment, and attachment components shall not fail, and shall create no hazardous conditions, such as small parts or sharp edges, as required in § 1242.3(b) and (c).

§ 1242.5 Test methods.

(a) *Test conditions.* (1) Condition the product for 48 hours at 23 °C +/- 2 °C (73.4 °F +/- 3.6 °F) and a relative humidity of 50% +/- 5%.

(2) Secure the firmness fixture to a test base such that the 3-in. head probe (figure 1 to § 1242.4(a)) does not deflect more than 0.01 in. (0.025 cm) under a 10 N (2.2 lb) load applied in each orientation required in the test methods.

(b) *Removal of components test method*—(1) *Equipment.* For torque and tension tests, any suitable device may be used to grasp the component, provided that it does not interfere with the attachment elements that are stressed during the tests.

(2) *Torque test.* Gradually apply a 4 lb-in. (0.4 N-m) torque over 5 seconds (s.) in a clockwise rotation to 180 degrees or until 4 lb-in. has been reached. Maintain for 10 s. Release and allow component to return to relaxed state. Repeat the torque test in a counterclockwise rotation.

(3) *Tension test.* For components that can reasonably be grasped between thumb and forefinger, or teeth, apply a 15 lb (67 N) force over 5 s., in a direction to remove the component. Maintain for 10 s. A clamp such as shown in figure 1 to this paragraph (b)(3) may be used if the gap between the back of the component and the base material is 0.04 in. (0.1 cm) or more.

Figure 1 to Paragraph (b)(3)—Tension Test Adapter Clamp



(c) *Permanency of labels and warnings.* (1) A paper label (excluding labels attached by a seam) shall be considered permanent if, during an attempt to remove it without the aid of tools or solvents, it cannot be removed, it tears into pieces upon removal, or such action damages the surface to which it is attached.

(2) A non-paper label (excluding labels attached by a seam) shall be considered permanent if, during an attempt to remove it without the aid of tools or solvents, it cannot be removed or such action damages the surface to which it is attached.

(3) A warning label attached by a seam shall be considered permanent if it does not detach when subjected to a 15-lbf (67-N) pull force applied in the direction most likely to cause failure using a 3/4-in. (1.9 cm) diameter clamp surface. Gradually apply the force within a period of 5 s. and maintain for an additional 10 s.

(4) *Adhesion Test for Warnings Applied Directly onto the Surface of the Product:*

(i) Apply the tape test defined in Test Method B of ASTM D3359-23 (incorporated by reference, see § 1242.8), eliminating parallel cuts.

(ii) Perform this test once in each different location where warnings are applied.

(iii) The warning statements will be considered permanent if the printing in the area tested is still legible and attached after being subjected to this test.

(5) A non-paper label, during an attempt to remove it without the aid of tools or solvents, shall not fit entirely within the small parts cylinder defined

in 16 CFR part 1501 if it can be removed.

(d) *Infant support surface firmness test method.* Perform the following steps to determine the infant support surface firmness of the product as received from the manufacturer.

(1) Conduct tests at three locations on the surface to be tested, with 3 in. (7.62 cm) or more separation: maximum thickness perpendicular to the test surface and two other locations most likely to fail. When selecting these locations, the edge of the probe shall not extend beyond the edge of the product. If the design or size of the product is such that the edge of the probe must extend beyond the edge of the product, the probe shall be centered over as much of the test surface as possible.

(2) Lay the product, with the infant support surface facing up, on a test base that is horizontal, flat, firm, and smooth.

(3) Prevent movement of the product in a manner that does not affect the force or deflection measurement of the product surface under test. Provide no additional support beneath the product.

(4) Orient the axis of the 3-in. head probe (figure 1 to § 1242.4(a)) perpendicular to the test surface and aligned with a force gauge and parallel to a distance measurement device or gauge. Zero the force gauge.

(5) Using a lead screw or similar device to control movement along a single direction, advance the probe onto the product and set the deflection to 0.0 in. when a force of 0.1 N (0.02 lb) is reached.

(6) Continue to advance the head probe into the product at a rate not to exceed 0.1 inch per second and pause when the force exceeds 10.0 N (2.24 lb), or the deflection is equal to 1.00 in. (2.54 cm).

(7) Monitor the force and wait for it to stabilize, meaning the force has not changed more than 0.1 N (0.02 lb) for at least 30 s. If, after the force stabilizes, the deflection is less than 1.00 in. and the force is 10.0 N or less, repeat paragraphs (d)(6) and (7) of this section.

(8) Record the final force and deflection amounts.

(9) Repeat the infant support surface firmness tests on any other infant support surface and in all manufacturer-intended configurations that could affect the infant support surface, such as the folding or layering of parts of the product.

(e) *Inner wall firmness test method.* For nursing pillows with a caregiver opening, perform the steps in paragraphs (d)(1) through (8) of this section on the inner wall of the caregiver opening, and perform the following, to determine the inner wall

firmness as received from the manufacturer. Repeat the inner wall firmness tests in all manufacturer-intended configurations that could affect the inner wall firmness.

(f) *Product conditioning firmness test method.* Following the firmness testing in paragraphs (d) and (e) of this section, perform the following steps to determine the product firmness after conditioning.

(1) Launder and dry the product according to the manufacturer's instructions.

(2) Repeat paragraph (d) of this section.

(3) Repeat paragraph (e) of this section.

(g) *Infant containment test method.*

(1) Lay the product, with the infant support surface facing up, on a test base that is horizontal, flat, firm, and smooth.

(2) For nursing pillows with a caregiver attachment, unsecure and move the caregiver attachment away from the caregiver opening.

(3) Place the 9-in. head probe (figure 2 to § 1242.4(b)) inside the caregiver opening such that the flat bottom of the probe rests on the test surface and the

probe's perimeter contacts the innermost surface of the caregiver opening.

(4) If the inner wall of the caregiver opening contacts the outwardly facing portions of the probe, or the inner wall interferes with placing the probe down, the caregiver opening is considered to constrain the probe. See figure 2 to this paragraph (g)(4). Do not include in the assessment any contact with a caregiver attachment.

Figure 2 to Paragraph (g)(4)—Infant Containment, Example

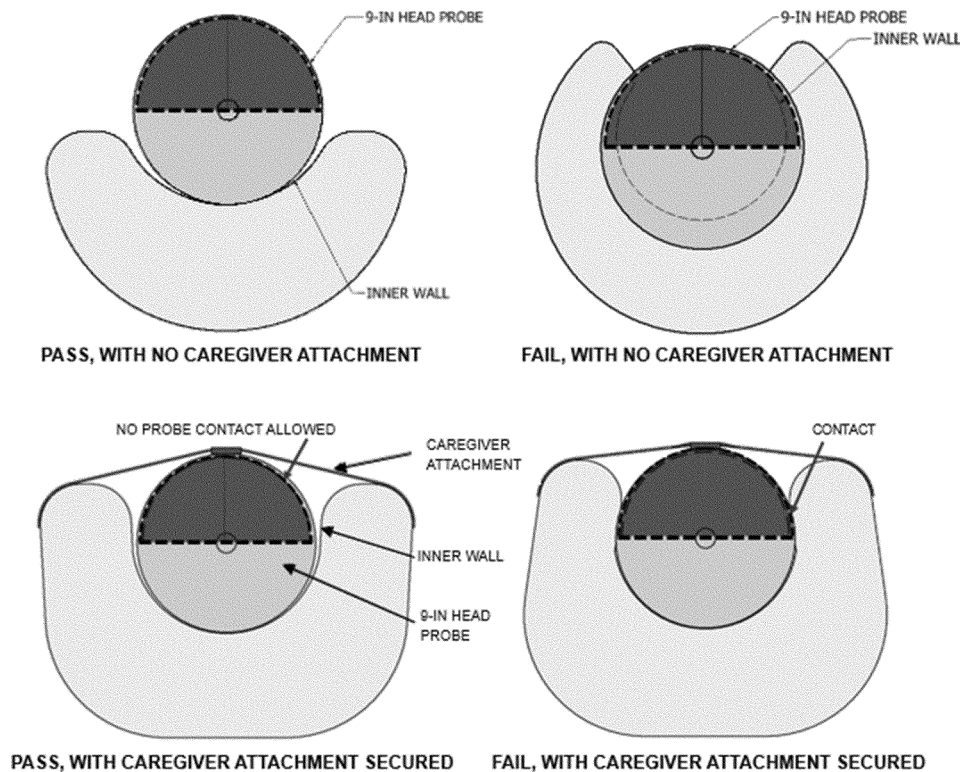

(5) With the probe at the position contacting the innermost surface within the caregiver opening, determine if any portion of the probe extends beyond a line projected across the outside limits of the caregiver opening.

(6) Slide the probe horizontally out of the caregiver opening to the outside of the nursing pillow. Determine if the probe is constrained by the inner wall of the caregiver opening contacting the

outwardly facing portions of the probe. See figure 2 to paragraph (g)(4) of this section. Do not include in the assessment any contact with a caregiver attachment.

(7) For nursing pillows with a caregiver attachment, adjust and secure the caregiver attachment to the minimum length allowed by the product and repeat paragraphs (g)(3) through (g)(5).

(h) *Seam strength test method.* (1) Equipment shall include clamps with 0.75 in. (1.9 cm) diameter clamping surfaces capable of holding fabric and with a means to attach a force gauge. Figure 3 to this paragraph (h)(1), or equivalent. The force gauge must have an accuracy of ± 0.5 lb (2.2 N).

Figure 3 to Paragraph (h)(1)—Seam Clamp

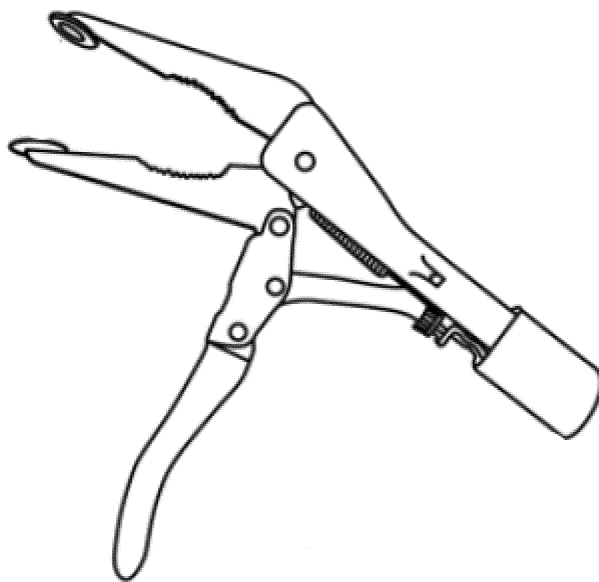

(2) Clamp the fabric of the nursing pillow on each side of the seam under test with the 0.75 in. clamping surfaces placed not less than 0.5 in. (1.2 cm) from the seam.

(3) Apply a tension of 15 lb (67 N) evenly over 5 s. and maintain for an additional 10 s.

(4) Repeat the test on every distinct seam and every 6 in. (15 cm) along each seam.

(i) *Caregiver attachment strength test method.* (1) Any suitable clamping devices with means to attach a force gauge with accuracy of 0.5 lb (1.2 N) may be used. The clamping surfaces shall grasp across the entire width of the strap or attachment element.

(2) Support the nursing pillow to resist the pull forces and release the buckle, clasp, or other fastener of the caregiver attachment.

(3) Clamp one side of the attachment or strap of the nursing pillow not less than 0.5 in. (1.2 cm) from the attachment to the nursing pillow.

(4) Apply a tension of 20 lb (89 N) evenly over 5 s. and maintain for an additional 10 s.

(5) Repeat the test on the other side of the attachment or strap.

(6) Join the buckle, clasp, or other fastener of the attachment or straps.

(7) Clamp both sides of the attachment or straps across the buckle, clasp, or other fastener, one on each side and not less than 0.5 in. (1.2 cm) from the fastener.

(8) Apply a tension of 20 lb (89 N) evenly over 5 s. and maintain for an additional 10 s.

§ 1242.6 Marking and labeling.

(a) Each product and its retail package shall be marked or labeled clearly and legibly to indicate the following:

(1) The name, place of business (city, state, and mailing address, including zip code), and telephone number of the manufacturer, distributor, or seller.

(2) A code mark or other means that identifies the date (month and year as a minimum) of manufacture.

(3) The marking or labeling in paragraphs (a)(1) and (2) of this section are not required on the retail package if they are on the product and are visible in their entirety through the retail package. When no retail packaging is used to enclose the product, the information provided on the product shall be used for determining compliance paragraphs (a)(1) and (2). Cartons and other materials used exclusively for shipping the product are not considered retail packaging.

(b) The marking and labeling on the product shall be permanent.

(c) Any upholstery labeling required by law shall not be used to meet the requirements of this section.

(d) Warning design for product:

(1) The warnings shall be easy to read and understand and be in the English language at a minimum.

(2) Any marking or labeling provided in addition to those required by this section shall not contradict or confuse the meaning of the required information or be otherwise misleading to the consumer.

(3) The warnings shall be conspicuous and permanent.

(4) The warnings shall conform to sections 6.1 through 6.4, 7.2 through 7.6.3, and 8.1 of ANSI Z535.4–2011, (incorporated by reference, see § 1242.8), with the following changes.

(i) In sections 6.2.2, 7.3, 7.5, and 8.1.2, replace “should” with “shall.”

(ii) In section 7.6.3, replace “should (when feasible)” with “shall.”

(iii) Strike the word “safety” when used immediately before a color (for example, replace “safety white” with “white”).

Note 1 to paragraph (d)(4). For reference, ANSI Z535.1, *American National Standard for Safety Colors*, provides a system for specifying safety colors. See note 1 to § 1242.8(b) for ANSI contact information.

(5) The safety alert symbol and the signal word “WARNING” shall be at least 0.2 in. (5 mm) high. The remainder of the text shall be in characters whose upper case shall be at least 0.1 in. (2.5 mm), except where otherwise specified.

Note 2 to paragraph (d)(5). For improved warning readability, avoid typefaces with large height-to-width ratios, which are commonly identified as “condensed,” “compressed,” “narrow,” or similar.

(6) The message panel shall meet the following text layout requirements.

(i) The text shall be left-aligned, ragged-right for all but one-line text messages, which can be left-aligned or centered.

Note 3 to paragraph (d)(6)(i). Left-aligned means that the text is aligned along the left margin, and in the case of multiple columns of text, along the left side of each individual column. See figure 1 to this paragraph (d)(6)(i) for examples of left-aligned text.

Figure 1 to Paragraph (d)(6)(i)—
Examples of Left-Aligned Text

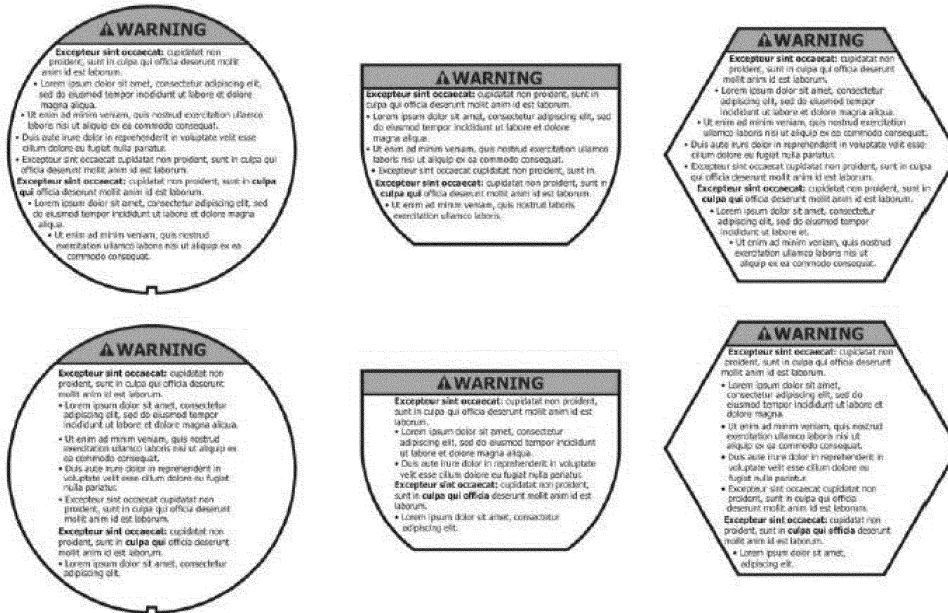

Note 4 to figure 1 to paragraph (d)(6)(i). The text shown for these warnings is filler text, known as lorem ipsum, commonly used to demonstrate graphic elements.

(ii) The text in each column should be arranged in list or outline format, with

precautionary (hazard avoidance) statements preceded by bullet points. Multiple precautionary statements shall be separated by bullet points if paragraph formatting is used.

(7) An example warning in the format described in this section is shown in figure 2 to this paragraph (d)(7).

Figure 2 to Paragraph (d)(7)—Example of Warning

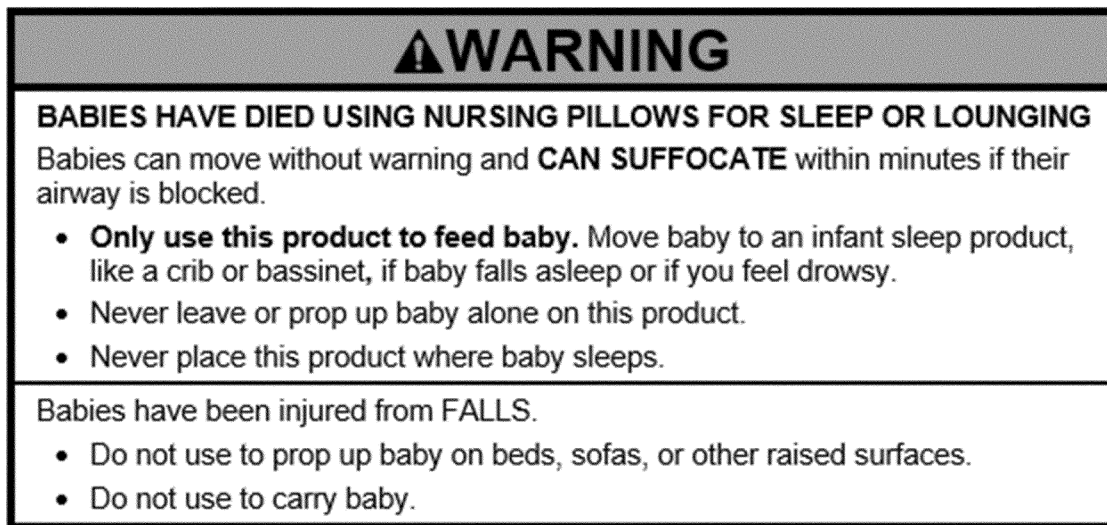

(e) *Warning statements.* Each product shall have warning statements. The text must address the warnings as shown in figure 2 to paragraph (d)(7) of this section.

Note 5 to paragraph (e). “Address” means that verbiage other than what is shown can be used as long as the meaning is the same or information that is product-specific is presented.

(f) *Package warnings.* (1) The warnings and statements are not required on the retail package if they are on the product and are visible in their entirety through the retail package. Cartons and other materials used exclusively for shipping the product are not considered retail packaging.

(2) Each product’s package shall have warning statements to address the

following, at a minimum, as specified in paragraphs (d)(1) and (2) and (4) through (6) of this section:

- (i) Do not use for sleep.
- (ii) Do not use in sleep products like cribs, bassinets, or play yards.
- (3) Each product’s retail package shall address the manufacturer’s recommended weight, height, age, or

developmental stage or combination thereof of the infant.

(4) Warnings, statements, or graphic pictorials on the product and package shall not indicate or imply that the infant may be left in the product without an adult caregiver in attendance.

§ 1242.7 Instructional literature.

(a) Instructions shall be provided with the product and shall be easy to read and understand and shall be in the English language at a minimum. These instructions shall include information on assembly, maintenance, cleaning, and use, where applicable.

(b) The instructions shall include all warnings specified in § 1242.6(e).

(c) The instructions shall address the following additional warnings:

(1) Read all instructions before using this product.

(2) Keep instructions for future use.

(3) Do not use this product if it is damaged or broken.

(4) Instructions shall indicate the manufacturer's recommended maximum weight, height, age, developmental level, or combination thereof, of the infant for whom the nursing pillow is intended. If this product is not intended for use by a child for a specific reason, the instructions shall so state this limitation.

(d) The cautions and warnings in the instructions shall meet the requirements specified in § 1242.6(d)(4) through (6) of this section, except that sections 6.4 and 7.2 through 7.6.3 of ANSI Z535.4—2011, need not be applied. However, the signal word and safety alert symbol shall contrast with the background of the signal word panel, and the cautions and warnings shall contrast with the

background of the instructional literature.

Note 1 to paragraph (d). For example, the signal word, safety alert symbol, and the warnings may be black letters on a white background, white letters on a black background, navy blue letters on an off-white background, or some other high-contrast combination.

(e) Any instructions provided in addition to those required by this section shall not contradict or confuse the meaning of the required information or be otherwise misleading to the consumer.

Note 2 to paragraph (e). For additional guidance on the design of warnings for instructional literature, please refer to ANSI Z535.6, *American National Standard: Product Safety Information in Product Manuals, Instructions, and Other Collateral Materials*. See note 1 to § 1242.8(b) for ANSI contact information.

§ 1242.8 Incorporation by reference.

Certain material is incorporated by reference into this part with the approval of the Director of the Federal Register approves this incorporation by reference in accordance with 5 U.S.C. 552(a) and 1 CFR part 51. All approved incorporation by reference (IBR) material is available for inspection at the U.S. Consumer Product Safety Commission and at the National Archives and Records Administration (NARA). Contact the U.S. Consumer Product Safety Commission at: the Office of the Secretary, U.S. Consumer Product Safety Commission, 4330 East-West Highway, Bethesda, MD 20814, phone (301) 504-7479, email: cpsc-os@cpsc.gov. For information on the availability of this material at NARA, go to: www.archives.gov/federal-register/cfr/ibr-locations. or email [\[nara.gov\]\(http://nara.gov\). The material may be obtained from the following sources:](mailto:fr.inspection@</p>
</div>
<div data-bbox=)

(a) ASTM International (ASTM), 100 Barr Harbor Drive, P.O. Box CB700, West Conshohocken, Pennsylvania 19428-2959; phone: (800) 262-1373; website: www.astm.org.

(1) ASTM D3359-23 Standard Test Methods for Rating Adhesion by Tape Test, approved February 1, 2023; § 1242.5(c).

(2) [Reserved]

(b) National Electrical Manufacturers Association (NEMA), 1300 17th St. N, Arlington, VA 22209; phone: (703) 841-3200; website: www.nema.org.

(1) ANSI Z535.4-2011(R2017), American National Standard for Product Safety Signs and Labels, ANSI-approved October 20, 2017 (ANSI Z535.4-2011); §§ 1242.6(d).

(2) [Reserved]

Note 1 to paragraph (b). NEMA standards are also available from ANSI, which provides a free, read-only copy of the standard at <https://ibr.ansi.org/Standards/nema.aspx>. American National Standards Institute (ANSI), 25 West 43rd Street, 4th Floor, New York, NY 10036, USA, telephone: (212) 642-4900, www.ansi.org.

§ 1242.9 Severability.

The provisions of this part are separate and severable from one another. If any provision is stayed or determined to be invalid, it is the Commission's intention that the remaining provisions shall continue in effect.

Alberta E. Mills,

Secretary, Consumer Product Safety Commission.

[FR Doc. 2024-24403 Filed 10-24-24; 8:45 am]

BILLING CODE 6355-01-P