

1
Ag 84 Ah

FORAGE FIBER ANALYSES

(Apparatus, Reagents, Procedures,
and Some Applications)

Agriculture Handbook No. 379

Agricultural Research Service

UNITED STATES DEPARTMENT OF AGRICULTURE

Trade names are used in this publication solely for the purpose of providing specific information. Mention of a trade name does not constitute a guarantee or warranty of the product by the U.S. Department of Agriculture or an endorsement by the Department over other products not mentioned.

ACKNOWLEDGMENTS

The authors wish to acknowledge the following for their contributions in developing the detergent apparatus:

W. R. Delauder, formerly of the Animal Husbandry Research Division* and presently research technician, Jello Division, General Foods, Dover, Del.

W. P. Flatt, formerly of the Animal Husbandry Research Division and presently Director of the Experiment Station, University of Georgia, Athens, Ga.

B. Deinum, who formerly worked in the Animal Husbandry Research Division on a fellowship of The Netherlands Organization for the Advancement of Pure Science, and now at the Department of Field Crops and Grassland Husbandry, Agricultural University, Wageningen, The Netherlands.

*The name has been changed to Animal Science Research Division.

CONTENTS

	Page
Introduction	1
Chemical-fiber determinations	1
Apparatus	1
Materials	2
Description	4
Reagents	5
Analytical procedures	8
Neutral-detergent (cell-wall)	8
Acid-detergent fiber	8
Acid-detergent lignin	9
Permanganate lignin, cellulose, insoluble ash, and silica.....	9
Acid-detergent cutin	11
Crucible cleaning	11
Acid-detergent nitrogen	11
Pepsin-insoluble nitrogen	12
Hot-water-insoluble matter and its nitrogen content	12
In vitro rumen digestibility determination	12
Apparatus	12
Materials	12
Description	13
Reagents	13
Procedure	14
Sampling techniques	15
Sampling of dry feeds	15
Sampling of wet materials	15
Comparison of hot and cold sample weighing	17
Estimation of nutritive value from chemical data	18
Literature cited	20

FORAGE FIBER ANALYSES

(Apparatus, Reagents, Procedures, and Some Applications)

By H. K. GOERING, *research dairy husbandman*, and P. J. VAN SOEST, formerly ¹ *chemist*,
Animal Science Research Division, Agricultural Research Service

INTRODUCTION

This handbook has been written as a guide for those who wish to (1) set up the newer detergent system of fiber fractionation (4, 5, 9, 13),² (2) adapt their apparatus and equipment to the new analyses, and (3) estimate the digestibility directly by a modified (15) Tilley and Terry (3) two-stage in vitro rumen fermentation procedure.

Laboratory evaluation of forage is essentially aimed at obtaining analytical data that predict the extent of biological degradation under specified conditions, animals, organisms, and time. In general, an in vitro rumen fermentation reflects the factors known and unknown limiting availability of forage to the digesting organism. The analyst can assay only known constituents. The assays are for things that are expedient to handle, are known, or are considered important, and its evaluation is valid only if the principals

concerned are dominant in the sample. For example, it makes little sense to expect lignin to be a good predictor of digestibility if silica or some other factor is a more important variable. In vitro fermentations will be influenced by all factors and inhibitors known and unknown. The in vitro, however, does not disclose anything regarding the nature of the limiting factor. This latter task of identification remains the duty of chemical studies.

An attempt has been made to cover the principal problems in technique encountered in these procedures. These include sample preparation, filtration and washing, and efficiency in handling large numbers of samples. Ultimate laboratory efficiency is tied to the precision of duplicates and the repeatability of values. Handling of samples in drying and weighing and in ashing and reweighing is also discussed.

CHEMICAL-FIBER DETERMINATIONS

Apparatus

In general, equipment that is used for crude fiber may be adapted to the detergent fiber procedures. The reflux apparatus described is more convenient and cheaper than many other types available. However, if a laboratory contains a reflux apparatus for crude fiber, it may be used without modification. Other types of reflux apparatus probably are suitable if they conform to the following criteria: (1) a minimum of six

plates for reflux, (2) each plate or burner is individually regulatable and has sufficient power so that boiling solutions keep fibers in continuous suspension, (3) reflux containers are straight-sided and not conical, and (4) the condenser system is sufficient to keep volume of boiling solutions constant. In general, oil baths and large hotplates are not satisfactory for quantitative work.

The filtration apparatus described is highly recommended. In general, filtration manifolds suitable for crude fiber do not adapt well unless they conform to the following specifications. Samples that contain appreciable amounts of

¹ Presently associate professor, Animal Science Department, Cornell University, Ithaca, N.Y.

² Italic numbers in parentheses refer to Literature Cited, p. 20.

starch, protein, or other mucilaginous substance are often hard to filter when detergent-fiber analyses are being performed. Much difficulty is avoided by having an adequate filtering apparatus and by using proper technique. The main requirement is a filter manifold system with receivers for at least six crucibles. Filtration must be individually controlled for each crucible. Experience has shown that filtration of a difficult sample must begin with little to no vacuum and then be gradually increased. Often a very significant volume can be filtered without any vacuum. The addition of asbestos to the sample may help filtration, but this involves the laborious operation of preparing the asbestos before use and also makes subsequent analyses on the residue more difficult or impossible.

For convenience and most efficient routine operations, equipment must be situated so that the operator can perform on a regularly timed basis; also some extra time for incidental operations that arise should be allowed. It is very important to have solutions near areas of use and quantities large enough to last for several days of continuous analyses. An ashing oven equipped with a temperature regulator to prevent the glass crucibles from melting is required for cleaning the crucibles. With temperatures from 500° to 550° C. complete ashing of organic matter is accomplished in 2 to 3 hours.

Standardized methods in the laboratory are mandatory for obtaining precise analytical results. Enough equipment is required to adequately run a basic analysis, such as cell walls (neutral-detergent fiber), continuously for an 8-hour period. A 12-unit refluxing apparatus and a drying oven large enough to hold 80 crucibles make this possible. Technicians tend to make fewer mistakes when a standard laboratory procedure is used for all activities; and, if erratic results arise, the cause can be detected more easily. The possibility of overlooking a step in the procedure is also reduced.

Materials

1. Refluxing apparatus (figs. 1 and 2):
 - a. Beakers, Berzelius without spout, 600-ml. capacity
 - b. Crucibles, Gooch-type, high form Pyrex

fritted glass, 50-ml. capacity, coarse porosity. Type sold by Fisher Scientific, Silver Spring, Md., Cat. No. 8-237

- c. Scimatco rubber tubing, black, thick wall, $\frac{5}{16}$ -in. (8.0-mm.) bore, $\frac{3}{22}$ -in. (3.5-mm.) wall
- d. Hotplate, Thermolyne (HP-A8805B), blue-porcelain, steel flattop, 120 v., 3.3 a., 400 w., 3 $\frac{3}{4}$ -in. (9.5-cm.) diameter
- e. Multielectric 6-receptacle box, 20 a., 115 v. (needed if more than one hotplate is going to be used)
- f. Condensers, reflux, crude-fiber, Pyrex. E. H. Sargent and Company, Philadelphia, Pa., Cat. No. S-22742 or equivalent



BN-36457

FIGURE 1.—Arrangement of hotplates, rings, beakers, condensers, and hose.

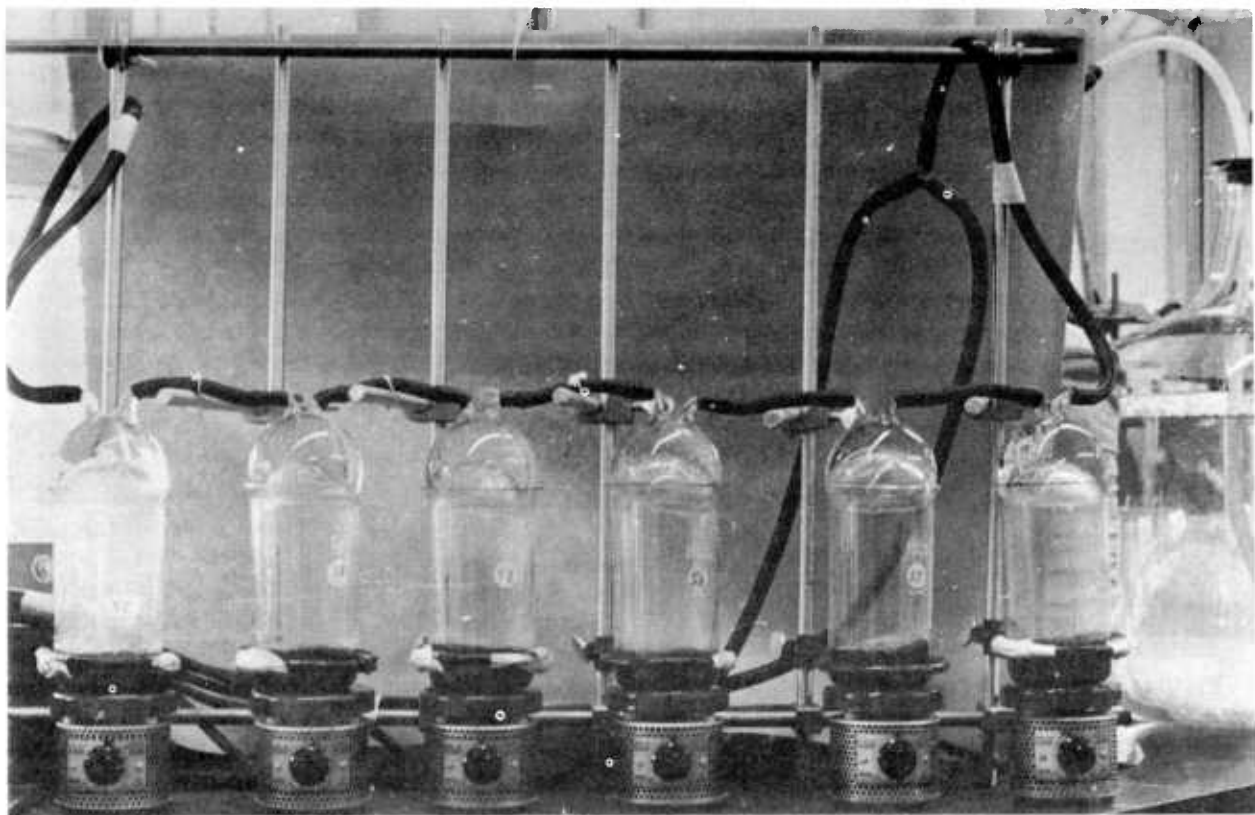
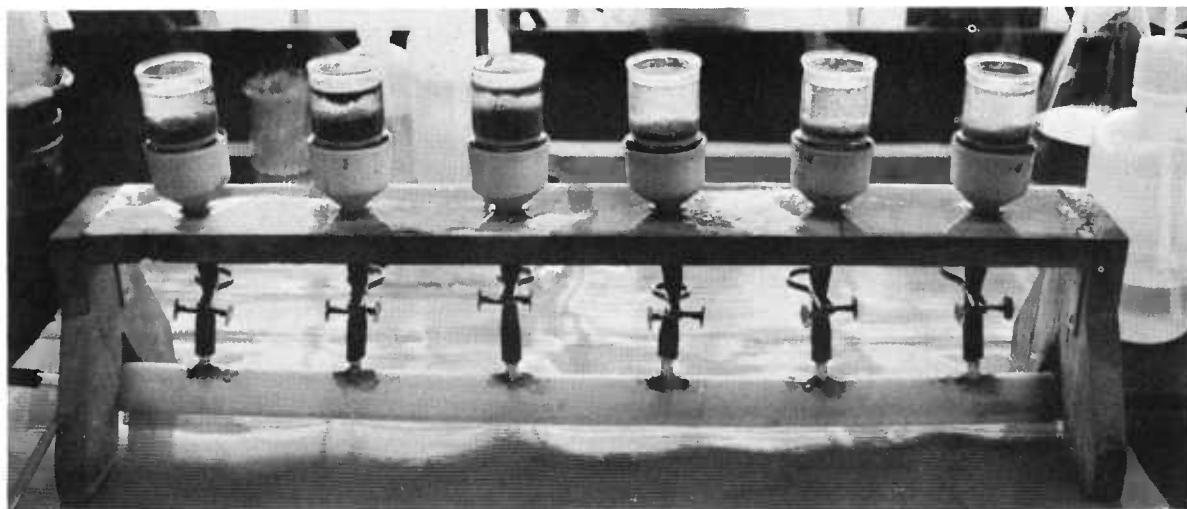

FIGURE 2.—Arrangement of six units of refluxing apparatus, with flexaframe support.

BN-36455

- g. Flexaframe hook connectors (need approximately 36 for a set of six hotplates)
- h. Rings, cast iron, 4-in. (10-cm.) OD
- i. Flexaframe rods:
 - 12 in. (30 cm.) (need 5)
 - 24 in. (60 cm.) (need 3)
 - 36 in. (90 cm.) (need 2)
- 2. Filter manifold (figs. 3-5):
 - a. Polyethylene pipe, 1-in. (2.5-cm.) ID, $\frac{1}{8}$ -in. (3-mm.) wall, 2 ft. (60 cm.)
 - b. Funnels, Büchner, porcelain, Coors 490, size-0
 - c. Flasks, filtering, Pyrex, 4-l. capacity
 - d. Clamps, pinchcocks, Mohr
 - e. Rubber adapter, size-B. Fisher Scientific Co., Silver Spring, Md., Cat. No. 8-239
 - f. Rubber tubing, $\frac{1}{4}$ -in. (6-mm.) ID, $\frac{1}{8}$ -in. (3-mm.) wall
 - g. Glass tubing, 5-mm. OD, 3-mm. ID
 - h. Polyethylene tubing, $\frac{1}{8}$ -in. (3-mm.) ID, $\frac{1}{16}$ -in. (1.5-mm.) wall
 - i. Screw clamp
- 3. Water heater (fig. 6):
 - a. Ring support, cast iron with clamp, 6-in. (15-cm.) OD
 - b. Flask, distilling, 2 l., 3 neck
 - c. Quartz immersion heater, 1,000 or 500 w., 120 v. Ace Glass, Inc., Vineland, N. J., Cat. No. 2145-12 or 2145-10
 - d. Crucible holder, filter tubes, Pyrex, 10-mm. diameter (for automatic filling of large flask)
 - e. Bottle, Pyrex, 5-gal. (18-l.) capacity
 - f. Transformer, variable, 10 a.
 - g. Condenser
 - h. Flexaframe rods, 18 in. and 48 in. (45 cm. and 120 cm.)
 - i. Clamp, versatile, vinylized jaws, medium size (need 2)
 - j. Clamps, pinchcock, Day
 - k. Y connection, $\frac{3}{16}$ -in. (48-mm.) OD, metal
 - l. Burette tip



BN-36409

FIGURE 3.—Filter manifold.

Description

Figure 1 shows a section of the refluxing apparatus. Ceramic hotplates, $3\frac{3}{4}$ -inch, 120 v., are used to produce sufficient heat to boil 200 ml. of liquid in the beaker. Ceramic plates protect coils from liquids spilled on the plate, which avoids electrical problems. Special Pyrex glass reflux condensers rest on top of the beaker, which are otherwise supported by the rubber tubing connected to the condensers. Thick-wall $\frac{5}{16}$ -in. (8.0-mm.) bore rubber tubing is used to connect the condensers in a series of six. Parts of refluxing apparatus are supported with flexaframe unit. Rings covered with rubber tubing are placed above the hotplate to prevent knocking off the beaker. Figure 2 shows the complete six-unit refluxing apparatus, which requires a multielectric six-receptacle box with a minimum of 20 a.

The filter manifold is shown in figures 3, 4, and 5. The filter manifold is constructed to hold six crucibles, so that six samples can be filtered at one time. The manifold is made from large polyethylene pipe, 2 feet (60 cm.) in length with a 1-inch (2.5-cm.) inside diameter (ID). Six polyethylene tubes are attached into the larger tube. A glass lining (5-mm. outside diameter (OD) tubing) is inserted inside each small polyethylene tube. The joints are welded with a polyethylene welding rod to prevent leakage and maintain vacuum. Thick-wall rubber tubing

connects each of these small tubes to size 0 Büchner funnels, to prevent collapsing from the vacuum. The funnels are supported on a 1- x 4-in. wooden frame, constructed as shown in figures 3 and 4. Holes are drilled to hold the funnels to give adequate working room for filtering the sample. The rubber adapters (Fisher 8-239) are inserted into the Büchner funnels to give a vacuum seal. Heavy-wall rubber tubing connects from the manifold to two 4-l. side-arm flasks, which serve as traps. Vacuum level is controlled by attaching a rubber tube with a screw clamp to the opposite end of the polyethylene manifold. A pinch type clamp closes each tube coming from the Büchner funnel, which makes it possible to control each crucible individually.

The third component of the detergent apparatus, the hot-water system, is constructed directly above the filtering manifold (fig. 6). Water is stored in an elevated carboy reservoir above and to the side of the heater. A closed siphon is connected with a leveling device (seen on the left of the large flask in figure 6), a 2-l., 3-neck distilling flask with a well at the bottom to allow space for the immersion heater (about 50 x 120 mm.), and a water inlet to the bottom of the well. Water enters from the reservoir into the leveling device and then goes directly to the bottom of the well. A tube connects from the leveling device to the reservoir to serve as an air vent. Also, an air vent is placed on the level-

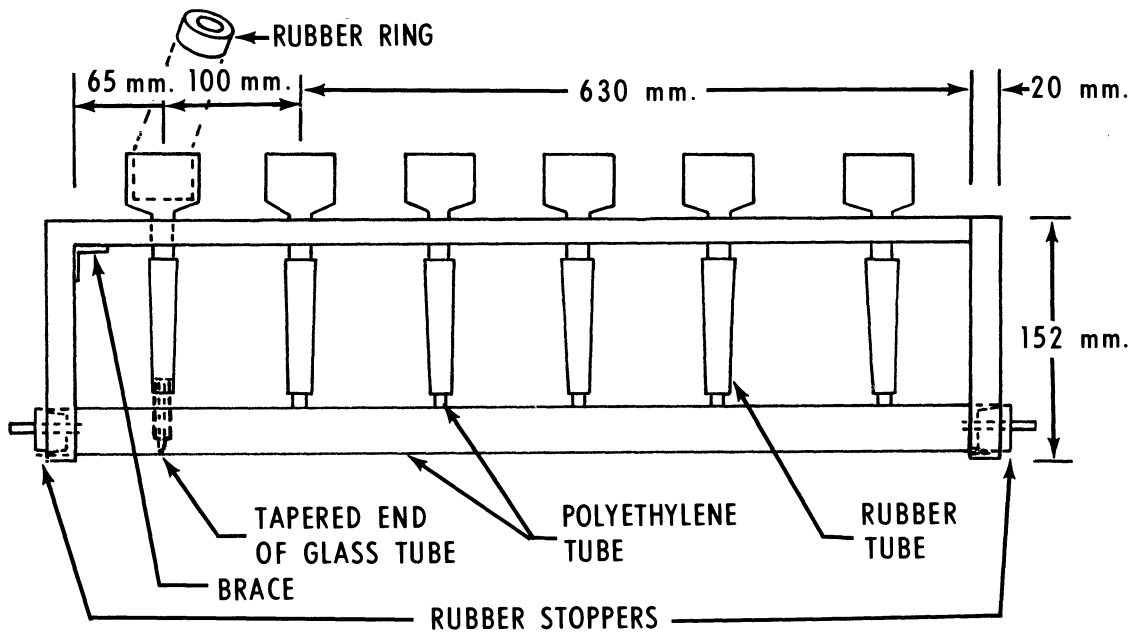

FIGURE 4.—Side diagram of filter manifold.

ing device. The 2-l. flask then fills automatically; a constant supply of hot water is thus maintained. A condenser at the top of the flask prevents loss of steam. The water-heating apparatus is supported on one flexaframe rod. Vinylized clamps are used to allow for expansion of glassware due to temperature change. A thick-wall hose feeds water to the filtering manifold.

The hose terminates with a Y connector, fitted on one end with a burette tip end and on the other with a tube, which allows each to be clamped off. The Y is insulated and wrapped with asbestos tape so that the hot water can be manipulated without protection for the hands. A workable water system is essential for the fast washing of the detergent from the residues in the crucibles. A variable transformer with a capacity of 10 a. and a 1,000-w. water heater (Ace glass quartz heater) should be used to control water temperature.

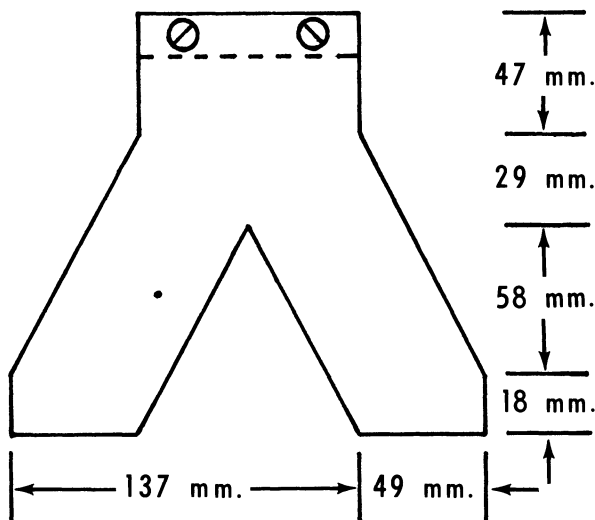

FIGURE 5.—End diagram of filter-manifold frame.

A convenient setup is shown in figure 7. The water system is directly above the filter manifold with two sets of six refluxing units on each side. This setup allows for refluxing detergents continuously and also allows the technician sufficient time for filtering and washing of the residues.

Reagents

1. Neutral-detergent solution—

Distilled water	l	1	18	40
Sodium lauryl sulfate, USP	g	30	540	1,200
Disodium ethylenediaminetetraacetate						

tate (EDTA), dihydrate crystal, reagent grade.....	g	18.61	335.0	744.4
Sodium borate de- cahydrate, re- agent grade	g	6.81	122.6	272.4
Disodium hydrogen phosphate, anhy- drous, reagent grade	g	4.56	82.1	182.4
2-ethoxyethanol (ethylene glycol monoethyl ether), purified grade ..	ml	10	180	400

Put EDTA and $\text{Na}_2\text{B}_4\text{O}_7 \cdot 10\text{H}_2\text{O}$ together in a large beaker, add some of the distilled water, and heat until dissolved; then add to solution containing sodium lauryl sulfate and 2-ethoxyethanol (ethylene glycol monoethyl ether). Put Na_2HPO_4 in beaker, add some of the distilled water, and heat until dissolved; then add to solution containing other ingredients.

Check pH to range 6.9 to 7.1. If solution is properly made, pH adjustment will rarely be required.

2. Decahydronaphthalene—Reagent grade.
3. Acetone—Use grade that is free from color and leaves no residue upon evaporation.
4. Sodium sulfite—Anhydrous, reagent grade.
5. Acid-detergent solution—

Sulfuric acid, reagent grade standardized to 1 N. (100 = percent assay)	g	49.04	882.72
Cetyl trimethylam- monium bromide (CTAB), technical grade	g	20	360

Weigh sulfuric acid and make up to volume with distilled water at 20° C. Check normality by titration before addition of detergent. Then add CTAB and stir.

6. n-Hexane—Technical grade.
7. Asbestos—Place 100 g. (long fiber) in a 3-l. flask with 850 ml. water. Add 1,400 ml. concentrated H_2SO_4 (technical grade), mix, and let cool at room temperature for 2 hours. Filter on a large Büchner funnel, and wash with water. Resuspend mat in water and pour into

a square bag sewn from a rectangle of fiber-glass window screening of 14 x 18 mesh (about 1 mm.) (the bag should be at least 18 inches (46 cm.) wide by 12 inches (30 cm.) deep). Wash by immersion and agitation in water to remove fine particles. Ash the recovered asbestos in a furnace at 800° C. for 16 hours. Store in dry form until needed. Used asbestos can be rewashed, ashed, and reused.

8. Sulfuric acid, 72 percent by weight—Calculate grams acid and water needed in 1 l. of solution by:

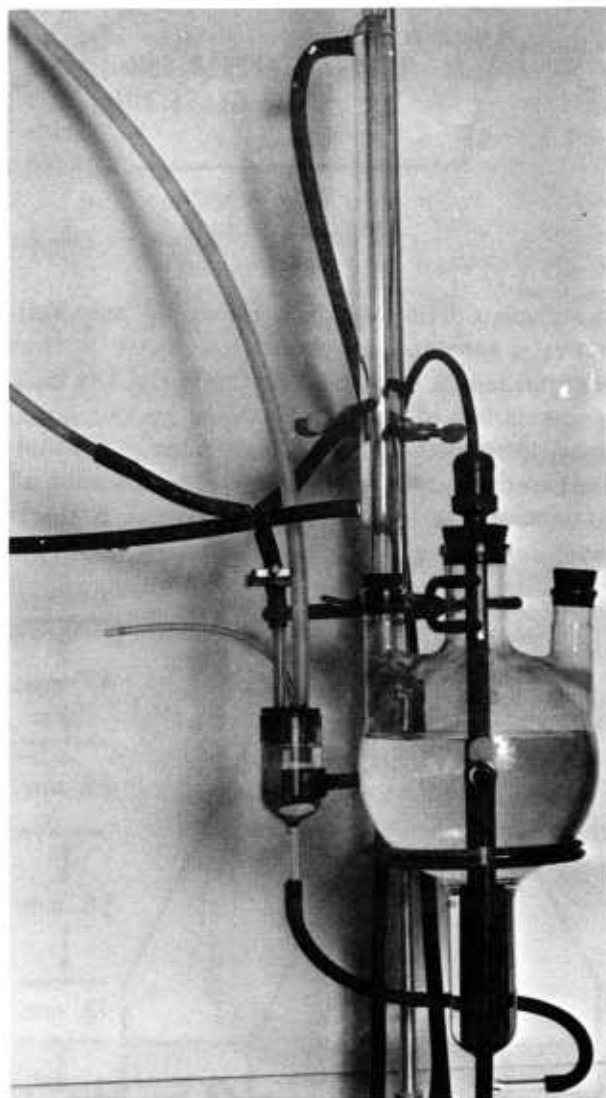

BN-36456

FIGURE 6—Hot-water heating system.



BN-36458

FIGURE 7.—Assembly of 12 units of refluxing apparatus with filter manifold and hot-water system.

$$\frac{100 \times 98.08 \times 12 \text{ moles}}{\text{H}_2\text{SO}_4 \text{ assay (percent)}} = \text{grams acid needed}$$

$$(1,000 \times 1.634)^3 - \text{grams acid} = \text{grams water needed}$$

Weigh amount of water into a 1-l. MCA volumetric flask (with a bulb in the neck) and add the calculated amount of H_2SO_4 slowly with occasional swirling. Caution! Flask must be cooled in a water bath (sink) in order to add the required weight of sulfuric acid. Cool to 20°C . and check if volume is correct. If volume is too small, take out about 1.5 ml. and add 2.5 ml. water. Repeat, if necessary. If volume is too large, take out 5 ml. and add 4.45 ml. H_2SO_4 . Meniscus should be within a 0.5 cm. of calibration mark at 20° .

³ Weight of 1 l. of 72 percent H_2SO_4 .

9. Saturated potassium permanganate—

Distilled water	1	1	18
KMnO_4 , reagent grade .. g	50		900
Ag_2SO_4 , reagent grade .. g	0.05		0.9

Dissolve KMnO_4 and Ag_2SO_4 in distilled water. Keep out of direct sunlight. Add silver sulfate to dehalogenate the reagent.

10. Lignin buffer solution—

	1 l.	12 l.	
Ferric nitrate nonahydrate	g	6	72
Silver nitrate	g	.15	1.8
Acetic acid, glacial .. ml	500		6,000
Potassium acetate ... g	5		60
Tertiary butyl alcohol	ml	400	4,800
Distilled water	ml	100	1,200

Dissolve ferric nitrate nonahydrate [Fe

(NO₃)₃ · 9H₂O] and silver nitrate in distilled water. Combine with acetic acid and potassium acetate. Add tertiary butyl alcohol and mix. Use grades of acid and solvent passing dicromate test (ACS).

11. Combined permanganate solution—Combine and mix saturated potassium permanganate and lignin buffer solution in the ratio of 2:1, by volume, before use. Unused mixed solution may be kept about a week in a refrigerator in the absence of light. Solution is usable if purple and containing no precipitate. Old solutions assume a reddish color and should be discarded.

12. Demineralizing solution—

	1 l.	18 l.
Oxalic acid dihydrate	g 50	900
95 percent ethanol	ml 700	12,600
Concentrated (about 12 N) hydrochloric acid	ml 50	900
Distilled water	ml 250	4,500

Dissolve oxalic acid dihydrate in 95 percent ethanol. Add concentrated hydrochloric acid and distilled water and mix.

13. Ethanol 80 percent—

	1 l.	18 l.
95 percent ethanol	ml 845	15,200
Distilled water	ml 155	2,800

14. Hydrobromic acid, reagent grade.

15. Cleaning solution—

Distilled water	l 1	1
Disodium ethylenediaminetetraacetate (EDTA), dihydrate crystal, reagent grade	g 5	
Trisodium phosphate, laboratory grade	g 50	
Potassium hydroxide	g 200	

16. 0.1 N HCl—Add 17 ml. 6 N HCl to 1 l. of distilled water. Need not be standardized.

17. Pepsin—NF (Fisher Scientific, Cat. No. P-53).

Analytical Procedures⁴

Neutral-detergent (cell-wall)

The neutral-detergent procedure for cell-wall constituents is a rapid method for analyzing the

⁴ Numbers given after "Reagents required" refer to numbers in the reagent section, p. 5.

total fiber in vegetable feedstuffs (13). It appears to divide the dry matter of feeds very near the point that separates the nutritively available (98 percent) and soluble constituents from those that are incompletely available and dependent on a microbial fermentation.

Reagents required: 1 through 4.

1. Weigh 0.5- to 1.0-g. air-dry sample ground to pass 20 to 30 mesh (1-mm.) or equivalent into a beaker of the refluxing apparatus.

2. Add in order, 100 ml. cold (room temperature) neutral-detergent solution, 2 ml. decahydronaphthalene, and 0.5 g. sodium sulfite with a calibrated scoop. Heat to boiling in 5 to 10 minutes. Reduce heat as boiling begins, to avoid foaming. Adjust boiling to an even level and reflux for 60 minutes, timed from onset of boiling.

3. Place previously tared Gooch crucibles on filter manifold. Swirl beaker to suspend solids, and fill crucible. Do not admit vacuum until after crucible has been filled. Use low vacuum at first and increase it only as more force is needed. Rinse sample into crucible with minimum of hot (90°–100° C.) water. Remove vacuum, break up mat, and fill crucible with hot water. Filter liquid and repeat washing procedure.

4. Wash twice with acetone in same manner and suck dry. Dry crucibles at 100° C. for 8 hours or overnight and weigh.

5. Report yield of recovered neutral-detergent fiber as percent of cell-wall constituents. Estimate cell soluble material by subtracting this value from 100.

6. Ash residue in the crucible for 3 hours at 500° to 550° C. and weigh. Report ash content as ash insoluble in neutral-detergent.

Acid-detergent fiber

The acid-detergent fiber procedure provides a rapid method for lignocellulose determination in feedstuffs (4, 5). The residue also includes silica. The difference between the cell walls and acid-detergent fiber is an estimate of hemicellulose; however, this difference does include some protein attached to cell walls. The acid-detergent fiber is used as a preparatory step for lignin determination.

Reagents required: 2, 3, and 5.

1. Weigh 1-g. air-dry sample ground to pass 20- to 30-mesh (1-mm.) screen or the approximate equivalent of wet material into a beaker suitable for refluxing.
2. Add 100 ml. cold (room temperature) acid-detergent solution and 2 ml. decahydronaphthalene. Heat to boiling in 5 to 10 minutes. Reduce heat as boiling begins, to avoid foaming. Reflux 60 minutes from onset of boiling; adjust boiling to a slow, even level.
3. Filter on a previously tared Gooch crucible, which is set on the filter manifold; use light suction. Break up the filtered mat with a rod and wash twice with hot water (90°–100° C.). Rinse sides of the crucible in the same manner.
4. Repeat wash with acetone until it removes no more color; break up all lumps so that the solvent comes into contact with all particles of fiber.
5. Optional wash with hexane. Hexane should be added while crucible still contains some acetone. (Hexane can be omitted if lumping is not a problem in lignin analysis.) Suck the acid-detergent fiber free of hexane and dry at 100° C. for 8 hours or overnight and weigh.
6. Calculate acid-detergent fiber:

$$(W_o - W_t) (100) / S = ADF$$

where: W_o = weight of oven-dry crucible including fiber;

W_t = tared weight of oven-dry crucible;

S = oven-dry sample weight

Acid-detergent lignin

In the acid-detergent lignin procedure, the acid-detergent fiber (*ADF*) procedure is used as a preparatory step (5). The detergent removes the protein and other acid-soluble material that would interfere with the lignin determination. The *ADF* residue consists of cellulose, lignin, cutin, and acid-insoluble ash (mainly silica). Treatment with 72 percent sulfuric acid dissolves cellulose. Ashing of the residue will determine the crude lignin fraction including cutin. For silica determination and separation of cutin and lignin, see the Permanganate and Acid-Detergent Cutin Procedures.

Reagents required: 2, 3, 5, 7, and 8.

1. Prepare the acid-detergent fiber (p. 8).
2. Add to the crucible containing the acid-detergent fiber an amount of asbestos about equal to the volume of fiber. Cover the contents of the crucible with cooled (15° C.) 72 percent H_2SO_4 and stir with a glass rod to a smooth paste, breaking all lumps. Fill crucible about half full with acid and stir. Let glass rod remain in crucible; refill with 72 percent H_2SO_4 and stir at hourly intervals as acid drains away. Crucibles do not need to be kept full at all times. Three additions suffice. Keep crucible at 20° to 23° C. After 3 hours, filter off as much acid as possible with vacuum; then wash contents with hot water until free from acid. Rinse and remove stirring rod.
3. Dry crucible at 100° C. and weigh.
4. Ignite crucible in a muffle furnace at 500° to 550° C. for 3 hours, and then cool to 100° and weigh.
5. Calculate acid-detergent lignin:

$$(Lx100)/S = ADL$$

where: L = loss upon ignition after 72 percent H_2SO_4 treatment;

S = oven-dry sample weight

Permanganate lignin, cellulose, insoluble ash, and silica

An indirect method to determine lignin was developed that makes possible the preparation of cellulose and insoluble ash in the same sample (14). The insoluble ash is an estimate of total silica content, which in many grasses is a primary factor in reducing digestibility. The permanganate lignin method is an alternative procedure to the 72 percent sulfuric acid method; each has its own advantages. Choice of methods depends on materials analyzed and on the purpose for which the values are to be used.

Advantages of the permanganate method over the 72 percent acid method include a shorter procedure for lignin *per se* while the residue is reserved for further analysis of cellulose and silica. The permanganate reagents are much less corrosive and require no standardization. The residue requires no filter aids, and lignin values are not subject to some interferences that affect 72 percent sulfuric acid lignin. Values are less affected by heat-damage artifacts and are closer to a true lignin figure.

However, cutin, which is important in many seed hulls, is not measured. A variation for the analysis of seed hulls is to prepare the permanganate cellulose and treat with 72 percent H_2SO_4 and asbestos for 3 hours as described in the acid-detergent lignin procedure. This results in the partitioning of crude lignin into two fractions as described in the acid-detergent cutin procedure.

One disadvantage to permanganate lignin is that large particles are poorly penetrated by the reagents and yield low values. Consequently, all materials must be dried and ground to pass through a 20- to 30-mesh (less than 1 mm.) screen, and the method is not applicable to fresh feces and forages that have been ground in a meat grinder. Because of high sensitivity to heat damage, 72 percent acid is preferred for assaying artifact lignin.

Theory of the method—Interfering matter is removed by preparing acid-detergent fiber, which is chiefly composed of lignin, cellulose, and insoluble minerals. Lignin is oxidized with an excess of acetic acid-buffered potassium permanganate solution, containing trivalent iron and monovalent silver as catalysts. Deposited manganese and iron oxides are dissolved with an alcoholic solution of oxalic and hydrochloric acids, which leaves cellulose and insoluble minerals. Lignin is measured as the weight lost by these treatments; whereas, cellulose is determined as the weight loss upon ashing. The ash residue is mainly silica and much of the non-silica matter can be removed by leaching with concentrated hydrobromic acid.

Reagents required: 2, 3, 5, 6, 9 through 14.

1. Dry samples at less than 65° C. and grind through 20- to 30-mesh (1-mm.) screen. Prepare and determine acid-detergent fiber according to standard procedure. Use a 1-g. sample, except on samples containing a high amount of lignin (15 percent or more) use 0.5-g. sample. Place previously weighed crucibles in a shallow enamel pan containing cold water to a depth of about 1 cm. Fiber in crucibles should not be wet.
2. Add about 25 ml. of combined saturated potassium permanganate and lignin buffer solution (2:1 by volume) to the crucibles in the enamel pan containing cold water. Adjust level (2–3 cm.) of water in pan to reduce flow of solution out of crucibles. Place a short glass rod in each crucible to stir contents, to break lumps, and to draw permanganate solution up on sides of crucibles to wet all particles.
3. Allow crucibles to stand at 20° to 25° C. for 90 ± 10 minutes; add more mixed permanganate solution if necessary. Purple color must be present at all times.
4. Remove crucibles to filtering apparatus. Suck dry. Do not wash. Place in a clean enamel pan, and fill crucibles no more than half full with demineralizing solution. Demineralizing solution may be added directly to crucibles in case filtering is difficult. Care must be taken to avoid spillage by foaming. After about 5 minutes, suck dry on filter and refill half full with demineralizing solution. Repeat after second interval if solution is very brown. Rinse sides of crucibles with solution from a wash bottle with a fine stream. Treat until fiber is white. Total time required is 20 to 30 minutes.
5. Fill and thoroughly wash crucible and contents with 80 percent ethanol. Suck dry and repeat two times. Wash twice in similar manner with acetone. Suck dry.
6. Dry at 100° C. overnight and weigh. Calculate lignin content as loss in weight from acid-detergent fiber.
7. Ash at 500° C. for 3 hours, cool, and weigh. Calculate residual ash as the difference between this weight and original tare of crucible. Calculate cellulose by weight loss upon ashing.
8. A presumptive analysis for silica may be obtained by hydrobromic acid treatment of the ashed permanganate lignin or *ADF* residue. This determination has its greatest value when the residual ash is greater than 2 percent. Ash and weigh, then add enough drops of 48 percent HBr to moisten all particles. Use no more than 4 ml. acid. Allow to stand 1 to 2 hours. Add more drops of HBr if much red color forms. Suck off excess acid on vacuum and wash once with acetone. *Use no water.* Dry and ash briefly at 500° C. Cool and weigh. Report silica as the difference between this weight and the original tare.

Precautions—Crucibles containing fiber of a high lignin content require more permanganate solution; however, avoid additions of more solution than is necessary. Appearance of a yellow or brown color indicates exhaustion of permanganate. If crucible is full, filter solution off on a vacuum and add more reagent. A yellow color persisting after treatment of fiber with demineralizing solution indicates incomplete removal of lignin. This occurs only in materials of a very high lignin content. Cutin material present in seedcoats and other plant parts is not oxidized by permanganate; thus, it is neither determined as lignin nor bleached with the treatments. Seedcoats appear as colored flecks among white cellulose particles, and thus they should not be confused with incomplete oxidation.

Excessive flow of permanganate solution through the crucibles should be avoided with samples of low lignin content, particularly in samples of immature grasses. With these, a single addition of permanganate solution suffices. Fiber from immature grasses is very rapidly delignified, and, therefore, there is danger of loss of cellulosic carbohydrates if the flow is too great. Reduction in flow is accomplished by adjusting the water level in the pan to near that in crucibles. These precautions are not needed with the demineralizing solution.

Acid-detergent cutin (2)

The fraction of plant material referred to as cutin is the fraction that is not oxidized by KMnO_4 and resists hydrolysis by 72 percent H_2SO_4 acid. This fraction can be very large, as in some seed hulls, or not important, as in the common forages. The relation of cutin to the nutritive value of the other plant constituents is not understood. However, the cutin factor is resistant to microbial degradation.

Reagents required: 2, 3, 5 through 13.

1. Follow procedure for KMnO_4 lignin and cellulose preparation up to the step where lignin can be calculated but the residue has not been ashed (steps 1–6, p. 10).
2. Treat the unashed residue with 72 percent H_2SO_4 , as in the acid-detergent lignin procedure.
3. Calculate cutin as loss in weight upon ashing.

Crucible cleaning

Reagents required: 15.

1. Empty contents and ash crucibles briefly, 1 to 2 hours, at 500° to 550° C. (not necessary if crucible already ashed in lignin or silica determination).
2. Wash crucible with tapwater.
3. Force distilled water upward through the crucible; use a No. 7 rubber stopper with tube through middle connected to the distilled water outlet. Rinse outside with distilled water and place in oven. Proceed to next step if the crucible does not give normal filtering properties.
4. Place crucible that has been ashed in 500° to 550° C. in a shallow enamel pan. Add about 50 ml. crucible cleaning solution to each crucible. Heat (such as steam bath) should be placed under the pan. Let cleaning solution filter through crucible. Bore hole in a No. $9\frac{1}{2}$ rubber stopper and insert one end of a 50-ml. pipette and attach a tube to the upper end of the pipette. Place the stopper assembly in the top of the crucible and apply vacuum until the crucible is approximately one-half full of cleaning solution. Wait for solution to filter through crucible again. Refill the crucible with the solution again. The cleaning solution may be saved and reused.
5. Repeat steps 2 and 3.

Acid-detergent nitrogen

Heat-drying of forages at temperatures above 50° C. shows analytically significant increases in yield of lignin and fiber. The increased yield of acid-detergent fiber (*ADF*) can be accounted for largely by the production of artifact lignin via the nonenzymic browning reaction. Value for *ADF* and lignin in dried forages can be corrected on the basis of the nitrogen content of the *ADF* (1, 9). The nitrogen content of the *ADF* is suggested as a sensitive assay for nonenzymic browning due to overheating of feeds.

Reagents required: 2, 3, and 5.

1. Follow step 1 and 2 of acid-detergent fiber procedure using a 2-g. sample, page 8.
2. Filter with suction on previously tared 12.5-cm. Whatman No. 54 paper. Fold paper into

- a cone and use 60° angle funnel and a filter cone (Fisher No. 9-760) to protect tip.
- Wash paper with hot water and then acetone until acid free. Dry at 100° C. for 8 hours or overnight and weigh.
 - Transfer paper residue into Kjeldahl flask. Run nitrogen on residue in flask according to standard Kjeldahl procedure.
 - Calculate *ADF*:

$$(W_o - W_t)(100)/S = ADF$$
 where: W_o = weight of oven-dry filter paper including fiber;
 W_t = tared weight of oven-dry filter paper;
 S = oven-dry sample weight
 - Express *ADF-N* as percent of total DM:

$$N(100)/S = ADF-N$$
 where: N = grams of nitrogen;
 S = oven-dry sample weight.
 Another way of expressing the *ADF-N* is *ADF-N*/total nitrogen (100).

Pepsin-insoluble nitrogen (1)

Reagents required: 16 and 17.

- Weight 0.5-g. of air dry sample ground to pass 20- to 30-mesh (less than 1-mm.) screen, into 125-ml. Erlenmeyer flask.
- Add 0.5 g. of pepsin and 50 ml. of 0.1 N HCl to flask, stopper, and swirl. Place in oven or water bath at about 39° C. for 20 hours.
- Filter on 12.5-cm. Whatman No. 4, 41, or 54 filter paper. Leach thoroughly with distilled water. One way to ascertain if all soluble nitrogen is leached out is to determine if all traces of HCl has been removed from the filter paper. The taste test can be used for this.
- Take filter paper containing pepsin insoluble residue and place in a Kjeldahl flask. Run

nitrogen according to standard Kjeldahl procedure.

- Calculate pepsin-insoluble nitrogen:

$$(g. N/oven-dry sample)(100)$$
 which can be expressed as:

$$(pepsin-insoluble N/total sample N)(100)$$

Hot-water-insoluble matter and its nitrogen content

This procedure gives an estimate of true protein nitrogen in forages. The forage sample is boiled in water, which coagulates the protein causing it to become water insoluble and remain in the cell of the forage.

- Weigh 2.0-g. sample into 600-ml. Berzelius beaker.
- Add 200 ml. distilled water to beaker and boil for 1 hour on refluxing apparatus.
- Filter with vacuum on a previously tared 12.5-cm. Whatman No. 54 filter paper on a 60° funnel and a filter cone to protect tip. Wash four times with hot water. Place in 100° C. oven for 8 hours and weigh.
- Take weighed filter paper residue and transfer to a Kjeldahl flask. Run nitrogen on residue and filter paper according to standard Kjeldahl procedure. Correct for filter by running Kjeldahl on filter paper itself.
- Calculate hot-water-insoluble matter (*HwIM*) including nitrogen (*HwIN*):

$$(W_r - W_t/oven-dry sample weight)(100) = HwIM$$

$$(g.N/oven-dry sample weight)(100) = HwIN;$$
 where: W_r = weight of filter paper plus insoluble residue;
 W_t = weight of filter paper
 This insoluble nitrogen can be used as an estimate of true protein in forages only (hot water insoluble N x 6.25).

IN VITRO RUMEN DIGESTIBILITY DETERMINATION

Apparatus

Materials

- Rumen-content source from an animal on a high cell-wall roughage (preferably a fistulated animal)
- Erlenmeyer flasks, 125 ml. (Pyrex, requiring No. 6 stoppers)
- Shaking water bath at 40° C. with holder for 18 flasks
- Manifold for 18 flasks constructed over water bath

5. Waring Blendor
6. CO₂ source
7. Cheesecloth
8. Glass wool and enclosed funnel assembly
9. Automatic syringe, 10 ml.
10. Glassware refluxing apparatus as used for detergent preparations

Description

Fermentations are conducted in 125-ml. Pyrex Erlenmeyer flasks (wide-mouth); 0.5-g. substrate, 40-ml. medium, and 10-ml. inoculum are used. Fermentation flasks are placed in a shaking water bath (capacity 18) and closed with No. 6 rubber stoppers. Stoppers are fitted with three openings: an inlet tube, a bunsen valve—both flush with the bottom of the stopper—and a gassing tube connected to a common manifold. The inlet tube is closed on the outside with a rubber sleeve and glass rod. The gassing tube should stop about 1 cm. above the surface of the liquid. The manifold is connected to a

supply of carbon dioxide and in parallel with a water manometer with a capacity of 60-cm. water pressure. Figure 8 shows the shaking water bath and CO₂ manifold apparatus.

Reagents

Trypticase—A pancreatic digest of casein, USP.
Sodium sulfide nonahydrate—Reagent grade.
1 N sodium hydroxide—Dissolve 4 g. in water and dilute to a liter.

Cysteine·HCl—J. T. Baker Co. grade or equivalent.

Resazurin—0.1 percent w/v solution.

6 N HCl—Dilute concentrated HCl (about 12 N) with an equal amount of water. Need not be standardized.

Pepsin—NF (Fisher Scientific, Cat. No. P-53).
Toluene—Commercial grade.

In vitro rumen buffer solution —

Distilled water	1	18
Ammonium bicarbonate ..	g	72
Sodium bicarbonate	g	630



BN-36454

FIGURE 8.—Arrangement of water bath for in vitro fermentations.

In vitro rumen macromineral solution —

Distilled water	l	1	18
Na ₂ HPO ₄ , anhydrous	g	5.7	102.6
KH ₂ PO ₄ , anhydrous	g	6.2	111.6
MgSO ₄ ·7H ₂ O	g	.6	10.5

In vitro micromineral solution —

CaCl ₂ ·2H ₂ O	g	13.2
MnCl ₂ ·4H ₂ O	g	10.0
CoCl ₂ ·6H ₂ O	g	1.0
FeCl ₃ ·6H ₂ O	g	8.0

Add to volumetric and bring volume to 100 ml. with distilled water.

Procedure

The in vitro rumen procedure is designed so that a true or apparent digestibility value can be obtained. The predicted true digestibility value is based on undigested cell-wall constituents. The predicted apparent digestibility value or value that is equal in magnitude to in vivo apparent values is based on the Tilley and Terry in vitro digestion technique that may contain bacterial residues and other pepsin-insoluble material. The in vitro procedure yielding true digestibility values is a faster method and requires little extra equipment in a laboratory containing a detergent apparatus.

The first five steps are common to both procedures.

- 1. Weigh sample.*—Weigh 0.5-g. sample (20 mesh or 1 mm.) into 125-ml. Erlenmeyer flask.
- 2. Prepare medium.*—Add in order 2 g. trypticase, 400 ml. water, and 0.1 ml. micromineral solution, and agitate to dissolve. Then add 200 ml. buffer solution, 200 ml. macromineral solution, and 1 ml. resazurin. Mix and add 40 ml. per 125-ml. flask.
- 3. Equilibration.*—Assemble and put stoppers and flasks in bath, admit carbon dioxide pressure (about 30 to 40 cm. water), and check bunsen valves. Open the inlet tubes and swirl flask while open and then close. Next prepare the reducing solution. Add 625 mg. cysteine hydrochloric acid, 95 ml. water, 4 ml. 1 N sodium hydroxide and dissolve; then add 625 mg. sodium sulfide nonahydrate and dissolve. Reduce carbon dioxide pressure to 3 or 4 cm., and inject 2 ml. reducing solution through the inlet tube with an automatic syringe; open and close each tube in turn. Swirl all flasks. Watch for reduction of medium, which is a change from a red color (oxidized) to colorless (reduced).
- 4. Prepare inoculum.*—Collect ingesta from a fistulated animal in a liter beaker, fill, cover with a watchglass to eliminate airspace. Discard the top layer of the ingesta, and blend 400 ml. of the remainder in a Waring Blendor for 2 minutes under carbon dioxide. Squeeze the blended mass through cheesecloth and filter through glass wool into a warm flask; thereafter keep the filtrate under carbon dioxide. Inoculate 10 ml. of the filtrate with an automatic syringe through inlet tubes of each fermentation flask.
- 5. Fermentation.*—Seal tubes and incubate 48 hours with shaking at a rate not to produce splashing. Adjust carbon dioxide pressure to 2 cm. water.
At the end of fermentation one of two procedures can be followed: The Tilley and Terry (3) filtration procedure (step 6) or treatment with neutral detergent (step 7). Flasks may be stored before proceeding with step 6 or 7. Add 1 ml. toluene as a preservative and refrigerate. Stopper with cork.
- 6. Tilley and Terry procedure (3, 15).*—Add 2 ml. 6 N HCl to each flask carefully to avoid excessive foaming. (This is sufficient to lower pH below 2.) Add 0.5 g. pepsin National Formulary grade (may be measured with a scoop). Swirl to dissolve. Add 1 ml. toluene, replace flasks in water bath, and incubate 48 hours. Remove flasks from water bath and filter on previously tared Whatman No. 4, 41, or 54 filter paper without suction. Rinse filter twice by filling (almost to overflowing) and allowing to drain to a low level. Fill filter with acetone and allow to drain and air-dry. Fold papers, dry at 100° C., and weigh. Dry matter on paper is done on separate circles. Use dry-matter factor to calculate dry weight for tared paper circles used in filtering. Separate blanks containing inoculum and medium, but not substrate, must be run simultaneously. Whatman No. 4, 41, or 54 filter paper and a

common forage such as orchardgrass are used as standards.

7. *Neutral-detergent procedure for estimation of true digestibility.*—Remove flasks from water bath after digestion or from refrigerator if stored. Wash with 100 ml. neutral-detergent solution into 600-ml. Berzelius beaker to make a total volume of 150 ml. Add 2 ml. decahydronaphthalene. Reflux for 1 hour, and filter on previously tared 50-ml., 40-mm. plate, coarse-porosity fritted-glass crucibles. Wash twice with hot water and twice with acetone,

and suck dry. Dry in oven at 100° C. and weigh. Blanks are not necessary.

8. *Calculations.*—Calculate true dry-matter digestibility:

100 – percent *ND* residue = true digestibility

Calculate by Tilley and Terry method:

$[1.00 - [(R - F) - \text{blank/oven-dry sample weight}]] \times 100 = \text{percentage digestibility}$

where: *R* = weight of residue and filter paper;

F = weight of filter paper;

Blank value is *R - F* when substrate is not added to medium.

SAMPLING TECHNIQUES

Preparatory and drying procedures cannot be standardized to one method that would be satisfactory for all conditions; the experimenter must choose intelligently those that suit his purpose. A variety of preparatory and drying methods are presented. Incompatibilities are generally noted.

laborative work should be obtained from existing stocks in this manner.

Subsampling for chemical analyses

Roll bottle thoroughly to obtain mixing. Insert spatula into different places to obtain sample for analytical work.

Sampling of Dry Feeds

Digestion trial

Chop hay to 1½ inches (about 3.5 cm.) through 1-inch (2.5-cm.) screen. Weigh and bag hay for individual feedings before digestion trial but after intake level has been established. Composite samplings from the bags to comprise not less than 5 kg. Dry sampled forage if necessary, but at less than 65° C. Grind in a large Wiley mill through 2-mm. (10-mesh) screen. Return all contents of mill to the sample. Collect in a large plastic bag and mix, by rolling partially filled bag on floor. Subsample from all parts of the bag to an amount of at least 2 kg. and grind through 1-mm. (about 20-mesh) screen. Allow ground material to equilibrate with air overnight before placing in enclosed containers.

Subsampling

Spread material on a smooth surface, preferably metal, and divide the pile into quarters. Select at least eight increments from all parts equally to obtain subsample. Samples for col-

Sampling of Wet Materials

Gross sampling

Cattle feces.—Mix (by hand or with a mechanical mixer) daily collection thoroughly on a clean surface, quarter, and subsample 1 kg. or 10 percent of wet weight. Store in a plastic container in a freezer. Daily samples may be thawed, composited, mixed, and subsampled at a later date.

Sheep feces.—Collect cumulative feces from at least 5 days' collection, and pass through a meat grinder with a 6-mm. plate. Clean grinder, add all contents to the ground mass, mix thoroughly, and subsample 1 kg. A salad chopper can be used in place of meat grinder. Store in a plastic container in a freezer.

Silages and fresh forages.—Pass not less than 2 kg. frozen silage through meat grinder with 6-mm. plate. Tie large plastic bag over the end of the grinder to collect ground material. Clean grinder and add all contents to ground mass, and mix thoroughly. A salad chopper can be used in

place of a meat grinder. Store bag and contents in a freezer.

Subsampling and handling of wet samples for laboratory analyses⁵

Thaw and empty contents of forage subsamples from the gross sampling onto a clean surface and cover with a large sheet of plastic. Mix material with hands under the plastic. Quarter and subsample forage and fill an 8-oz. (250-ml.) wide-mouth plastic polyethylene bottle not more than two-thirds full. For fecal material, mix in a plastic beaker with a food mixer (electric eggbeater) and subsample material to fill bottle two-thirds full. Close bottle with a plastic cap (puncture the cap with a spatula allowing the spatula to remain in place primarily within the bottle). Weigh closed container to 1 mg. and remove an amount of material with spatula equivalent to 0.5 to 2 gm. of dry matter to a requisite sample container. Replace cap-spatula assembly and reweigh bottle. Take difference between first and second weights as weight of sample taken. Weigh samples for dry-matter determination in conjunction with matter weighed for other determinations. Mix sample contents of bottle between weighing by stirring with spatula.

Technique is devised so that the loss of weight in wet sampled material and material adhering to the spatula does not effect the determination of net sample weight. Weighing the cap-spatula assembly as well as the sample bottle and contents before and after removing the sample eliminates this source of error. The cap-spatula assembly is removed after weighing is completed and then replaced with an ordinary cap. Bottles are refrozen; they may be rethawed, mixed, and subsampled for further analyses at a later time.

Alternate techniques for handling wet samples

Wet grinding with a Wiley mill.—Grind frozen material through an intermediate Wiley mill with a 2-mm. (10-mesh) screen. Add charges of dry ice to keep sample frozen. This procedure is equivalent to the grinding in a meat grinder, but it is not amenable to the handling of large samples.

Oven drying.—Weigh 500-g. sample into a 18-x 30-cm. tared pan and dry at 65° C. in a forced-draft oven. Remove pan and allow to equilibrate with air at room temperature for 24 hours. Weigh and calculate yield. Grind dried material through 1-mm. (about 25-mesh) screen in a Wiley mill. Grinding through finer screens (30- to 40-mesh) may tend to induce filtering problems.

Caution.—In feces and silages, loss of nitrogen as ammonia results from oven drying. In silages there is also a serious loss of volatile organic acids and caloric value. Damage to lignin, protein, and carbohydrates can occur in all oven-dried materials, so that true values of individual components may not be obtained.

Freeze drying.—Wet samples can be freeze dried and ground through a Wiley mill. Heat-damage is avoided, but loss of nitrogen in the form of ammonia occurs in feces and silages. Volatile fatty acids are lost in freeze drying.

Acetone drying (Suitable for lignin and other components of fiber and cell wall.)—Weigh 100 g. of wet ingesta into a 500-ml. wide-mouth Erlenmeyer flask and add 400 ml. of reagent-grade acetone. Shake thoroughly and allow to stand with occasional shaking for 1 hour. Shake and pour mixed contents into a 10-cm. fritted-glass, coarse-porosity, Büchner funnel previously tared to 0.1 g. Allow to settle before applying suction. Suck off excess acetone with vacuum. Remove vacuum and add 400 ml. fresh acetone, while stirring to wash any remaining fiber from Erlenmeyer flask. One washing is sufficient. Preparation need not be washed free of pigment. Preparation is sucked dry on the filter. Allow to air-dry for 24 hours at room temperature. If humidity is high, funnels containing fiber may be dried at 40° C. for 4 hours in a forced-draft oven. Weigh funnel plus contents and calculate yield of acetone-dried powder. Dry-matter determinations should be made on original wet ingesta. Dried acetone powders are ground in an intermediate Wiley mill. Store in a tightly stoppered container. Calculate oven-dry sample weight by multiplying acetone dry sample weight with the following correction factor:

$$\text{OD sample factor} = \frac{\text{dry matter of wet ingesta}}{\text{acetone powder yield}}$$

⁵ See below for alternate techniques.

COMPARISON OF HOT AND COLD SAMPLE WEIGHING

Problem.—Fiber and lignin determinations are made in open crucibles that cannot be covered or otherwise protected from the pickup of moisture. Since fiber and lignin are hygroscopic materials, great care must be taken to avoid errors due to moisture pickup. A "hot" weighing procedure was compared with a "cold" one when two types of desiccators were used.

Apparatus.—A forced-draft oven set at 100° C. in proximity to a single-pan automatic balance sensitive to 0.1 mg. and two desiccators, one containing silica gel and the other phosphorous pentoxide, were used.

Procedure.—For hot weighing, dry crucibles were placed in a forced-draft oven for a minimum of 2 hours before weighing. Crucibles were removed one at a time for weighing, placed on balance pan, and weighed rapidly. This weight was obtained 20 to 30 seconds after placing crucible on balance pan. The minimum weight attained on the vernier scale was recorded. After removal of the crucible, any deflection of the balance setting from zero was recorded. The zero deflection due to temperature change of the balance was subtracted or added (positive or negative) for each weight. The balance was readjusted to zero before weighing the next crucible.

For cold weighing, dry crucibles were placed in a forced-draft oven a minimum of 2 hours before placing in desiccators. Crucibles were placed in desiccators for a minimum of 20 minutes and then weighed.

Conclusions.—Since water absorption will be evidenced as an apparently higher fiber yield, the technique resulting in the lowest fiber yield is assumed to be most accurate. The data show that the hot-weighing technique is reproducible (table 1) and this technique gives lighter crucibles than the cold technique (table 2). Crucibles weighed from desiccators picked up moisture; hence, they weighed 2.8 (P₂O₅ desiccant) and 3.8 percent (silica gel desiccant) higher than those weighed hot.

TABLE 1.—*Reproducibility with the hot weighing procedure*

Crucible	Hot weight after drying for —			Average deviation
	3 hr.	6 hr.	24 hr.	
	G.	G.	G.	
1	34.6911	34.6924	34.6928	0.0007
2	34.7861	34.7856	34.7850	.0006
3	34.0462	34.0451	34.0470	.0015
4	34.1868	34.1877	34.1867	.0009
5	35.4202	35.4203	35.4205	.0001

From this comparison it is evident that the hot-weighing procedure is superior. The precision of the hot-weighing technique is dependent on reading the minimum weight within 20 to 30 seconds. The shifting from zero can be nonsignificant if a series of crucibles are weighed with a minimum but equal time between crucibles. Precision can be attained with practice. In the Beltsville laboratory, the procedure was found to be more rapid and precise than cold weighing. This technique is also used on filter paper.

TABLE 2.—*Difference in weight and yield of fiber from the hot technique when weighed by the cold technique with two desiccants*

Crucible	Tare weight ¹		Tare plus sample ¹		Relative fiber yield ²	
	Silica gel	P ₂ O ₅	Silica gel	P ₂ O ₅	Silica gel	P ₂ O ₅
	Mg.	Mg.	Mg.	Mg.	Percent	Percent
1	22.2	19.8	36.0	26.1	103.8	102.7
2	20.5	17.6	35.0	26.2	103.7	102.7
3	20.4	17.3	35.9	26.3	103.7	102.7
4	23.2	22.1	36.7	26.4	103.8	102.8
5	23.1	21.5	35.2	26.4	103.7	102.8
6	22.5	22.7	35.8	26.6	103.8	102.8
7	20.9	21.0	36.6	26.1	103.8	102.7

¹ Difference from hot weight.

² Apparent fiber as percentage of yield obtained by hot technique.

ESTIMATION OF NUTRITIVE VALUE FROM CHEMICAL DATA

A summative system of calculation of nutritive value is based on the assumption that individual chemical factors additively limit nutritive value. The most basic division in plant dry matter is between cellular contents and plant cell wall (7, 10, 13). As a result the summative digestibility equation can be formulated:

$$\text{Percent digestible dry matter} = 0.98S + WD_c - M$$

where: S = cellular contents of an average digestibility of 98 percent;

W = the percent cell-wall contents;

D_c = the estimated digestion coefficient of the cell walls;

M = estimated metabolic fecal losses.

The estimated metabolic losses for sheep average 12.9 units of digestibility, which value is always used. In estimating metabolic losses for cattle the following regression should be used:

$$M = 36.57 - 0.275X$$

where: M = estimated metabolic fecal losses;

X = estimated true digestibility;

if: $X = 50, 60, 70, 80, 90$

then: $M = 22.8, 20.1, 17.3, 14.5, 11.8,$ respectively.

Digestibility of cell walls is variable and depends on lignification, silicification, and other factors. Lignin is most important and is best expressed as a percentage of acid-detergent fiber (L/ADF). Cell-wall digestibility (D_c) can be estimated by the use of the appropriate equation for either permanganate or 72 percent acid lignin or, alternatively, values may be interpolated from table 3. Values above 80 percent digestibility deviate from the equations; the table allows for this.

There is one precaution to the use of lignin to estimate cell-wall digestibility; that is, artifact lignins produced by heating or drying forage can cause errors (6, 9). Corrections should be made if the forage in question is known to have undergone a history of heating. In order to correct lignin and acid-detergent fiber for heat damage, it is necessary to know the nitrogen content of acid-detergent fiber. This requires an extra Kjeldahl determination. Correction of lignin is made through a regression equation:

TABLE 3.—Conversion of $KMnO_4$ and 72 percent acid L/ADF ¹ ratios to estimated cell-wall digestibility

72 percent acid	Estimated cell-wall digestibility ² (D_c)	$KMnO_4$	Estimated cell-wall digestibility ³ (D_c)
4	90	5	92
6	85	8	88
7	81	10	84
8	76	11	80
9	72	12	76
10	68	13	73
11	65	14	70
12	62	15	67
13	59	16	65
14	57	17	62
15	55	18	60
16	52	19	57
17	50	20	55
18	48	21	53
19	46	22	51
21	43	24	48
23	40	26	44
25	37	28	41
27	34	30	38
30	30	35	32
35	25	40	28
40	21	45	24
45	17	50	21
50	13	60	14

¹ L/ADF , percentage of lignin in acid-detergent fiber.

² $147.3 - 78.9 \log_{10} [(L/ADF) 100]$.

³ $180.8 - 96.6 \log_{10} [(L/ADF) 100]$.

$$L_c = 1.208 L_o - 10.75 N_o + 0.42$$

where: L_c = corrected lignin;

L_o = the observed lignin;

N_o = the amount of nitrogen in acid-detergent fiber expressed on a whole-feed basis.

Artifact lignin = $L_o - L_c = L_a$. Acid-detergent fiber and cell-wall values are corrected by subtracting L_a . If heat damage has occurred, corrected lignin and acid-detergent fiber values must be used in the summative scheme.

In grasses, silica (SiO_2) is an important factor affecting digestibility, and a special term is introduced into the summative equation (11, 12). Plant metabolic silica causes a decline of 3.0 units per 1 percent of silica. This factor must not be applied when there is sand or soil contamination; the factor 1.4 should be used in such cases.

A detailed scheme of calculations is shown in table 4, where the successive effects of lignifica-

TABLE 4.—Scheme for using the summative equation

Component	Analytical value ¹	Factor	Digestible amount ²
Cellular contents	100—cell-wall constituents	0.98	Add
Lignification of cell wall ³	Cell-wall constituent analysis	From table 3	Add
Silica correction	SiO ₂ analysis	⁴ 3.0	Subtract
Heat-damage effect	Artifact lignin ³	1.0	Subtract
Estimated true DDM ⁵	Sum
Metabolic fecal matter ⁶	Subtract
Estimated apparent DDM ⁵	Difference

¹ All values must be expressed as percentage of whole dry matter.

² Analytical value is multiplied by factor to obtain the digestible amount and then the process indicated in this column is performed.

³ Acid-detergent fiber and lignin must be corrected if heat damage exists. Follow directions as given with equation.

⁴ The factor 3.0 is not appropriate for silicates of sand or soil contamination in forage. The silica correction can be ignored if insoluble ash is less than 2.0 percent.

⁵ DDM, digestible dry matter.

⁶ See discussion on variation of metabolic fecal matter, p. 18.

tion, silicification, heat damage, and metabolic losses from digestion are outlined.

An example of a poor-quality orchardgrass hay is given as a sample calculation. Forage was brown, showing visible evidence of having heated; it yielded the following analysis: cell walls of 72.0 percent, acid-detergent fiber 43.1 percent, and apparent acid-detergent lignin 5.51 percent, silica 5.40 percent (from appearance, obviously metabolic),⁶ and nitrogen content of acid-detergent fiber 0.58 percent.

First step is to calculate the correct lignin. This is done by substitution in the lignin-correction equation:

$$L_c = 1.208 \times 5.51 - (0.58 \times 43.1/100 \times 10.75) + 0.42 = 4.4$$

Then

$$\text{Artifact lignin} = 5.5 - 4.4 = 1.1.$$

and

$$\text{Corrected acid-detergent fiber} = 43.1 - 1.1 = 42.0.$$

Next step is to calculate the estimated cell-wall digestibility. This is done by dividing the corrected lignin by the corrected ADF to yield:

$$(L/ADF) 100 = (4.4/42.0) 100 = 10.5$$

This value is substituted in the regression:

⁶ Metabolic silica appears fibrous and white like filter paper cellulose. Soil contamination is usually colored and shows grains of sand.

$$D_c = 147.3 - 78.9 \log_{10} [(L/ADF) 100] = 67 \text{ percent.}$$

Values may also be interpolated from table 3. The summative relation is then set up as shown in table 5.

Estimation of voluntary intake (8).—Voluntary intake based on sheep data and cell-wall contents (CWC) has given the following regression:

$$\text{Intake as g/kg}^{.75} = 110.4 - \frac{1,716}{(100 - CWC)}$$

Intake estimates based on this regression are subject to large errors, and hence, should be used with caution. The relations between chemical compositions and intake are fairly consistent in some forage species but unpredictable in others.

TABLE 5.—Example of calculation of digestible dry matter (DDM) for orchardgrass hay

Component	Analytical value	Factor	Digestible amount ¹
Cellular contents	28	0.98	+27.4
Lignification of cell wall	72	.67	+48.2
Silica correction	5.4	3.0	-16.2
Heat-damage effect	1.1	1.0	- 1.1
Estimated true DDM	58.3
Metabolic fecal matter	-12.9
Estimated DDM	45.4

¹ Analytical value is multiplied by factor to obtain the digestible amount and then the process indicated in this column is performed.

LITERATURE CITED

- (1) GOERING, H. K., and VAN SOEST, P. J.
1967. EFFECT OF MOISTURE, TEMPERATURE, AND pH ON THE RELATIVE SUSCEPTIBILITY OF FORAGES TO NON-ENZYMIC BROWNING. *Jour. Dairy Sci.* 50:989 (Paper No. 103).
- (2) MEARA, M.L.
1955. THE WAXES, CUTIN AND SUBERIN. Peach, K., and Tracy, M. V., Eds., *Moderne Methoden der Pflanzenanalyse* 2:380-402.
- (3) TILLEY, J. M. A., and TERRY, R. A.
1963. A TWO-STAGE TECHNIQUE FOR THE IN VITRO DIGESTION OF FORAGE CROPS. *Jour. Brit. Grassland Soc.* 18:104-111.
- (4) VAN SOEST, P. J.
1963. USE OF DETERGENTS IN THE ANALYSIS OF FIBROUS FEEDS. I. PREPARATION OF FIBER RESIDUES OF LOW NITROGEN CONTENT. *Assoc. Off. Agr. Chem. Jour.* 46:825-829.
- (5) ———
1963. USE OF DETERGENTS IN THE ANALYSIS OF FIBROUS FEEDS. II. A RAPID METHOD FOR THE DETERMINATION OF FIBER AND LIGNIN. *Assoc. Off. Agr. Chem. Jour.* 46:829-835.
- (6) ———
1964. SYMPOSIUM ON NUTRITION AND FORAGE AND PASTURES: NEW CHEMICAL PROCEDURES FOR EVALUATING FORAGES. *Jour. Anim. Sci.* 23:838-845.
- (7) ———
1965. NON-NUTRITIVE RESIDUES: A SYSTEM OF ANALYSIS FOR THE REPLACEMENT OF CRUDE FIBER. *Assoc. Off. Agr. Chem. Jour.* 49:546-551.
- (8) ———
1965. SYMPOSIUM ON FACTORS INFLUENCING THE VOLUNTARY INTAKE IN RELATION TO CHEMICAL COMPOSITION AND DIGESTIBILITY. *Jour. Anim. Sci.* 24:834-843.
- (9) ———
1965. USE OF DETERGENTS IN ANALYSIS OF FIBROUS FEEDS. III. STUDY OF EFFECTS OF HEATING AND DRYING ON YIELD OF FIBER AND LIGNIN IN FORAGES. *Assoc. Off. Agr. Chem. Jour.* 48:785-790.
- (10) ———
1967. DEVELOPMENT OF COMPREHENSIVE SYSTEM OF FEED ANALYSES AND ITS APPLICATION TO FORAGES. *Jour. Anim. Sci.* 26:119-128.
- (11) ———
1968. STRUCTURAL AND CHEMICAL CHARACTERISTICS WHICH LIMIT THE NUTRITIVE VALUE OF FORAGES. *Forage: Economics/Quality*, ASA Spec. Pub. No. 13:63-76.
- (12) ——— and JONES, L. H. P.
1968. EFFECT OF SILICA IN FORAGES UPON DIGESTIBILITY. *Jour. Dairy Sci.* 51:1644-1648.
- (13) ——— and WINE, R. H.
1967. USE OF DETERGENTS IN THE ANALYSIS OF FIBROUS FEEDS. IV. DETERMINATION OF PLANT CELL-WALL CONSTITUENTS. *Assoc. Off. Analytical Chem. Jour.* 50:50-55.
- (14) ——— and WINE, R. H.
1968. DETERMINATION OF LIGNIN AND CELLULOSE IN ACID-DETERGENT FIBER WITH PERMANGANATE. *Assoc. Off. Analytical Chem. Jour.* 51:780-785.
- (15) ——— WINE, R. H., and MOORE, L. A.
1966. ESTIMATION OF THE TRUE DIGESTIBILITY OF FORAGES BY THE IN VITRO DIGESTION OF CELL WALLS. *Proc. 10th Internatl. Grassland Cong.*, pp. 438-441.