



A11107 259977

U.S. DEPARTMENT OF COMMERCE  
National Bureau of Standards

*NBS Special Publication 702*

# *Standards and Metadata Requirements for Computerization of Selected Mechanical Properties of Metallic Materials*

*Jack H. Westbrook*

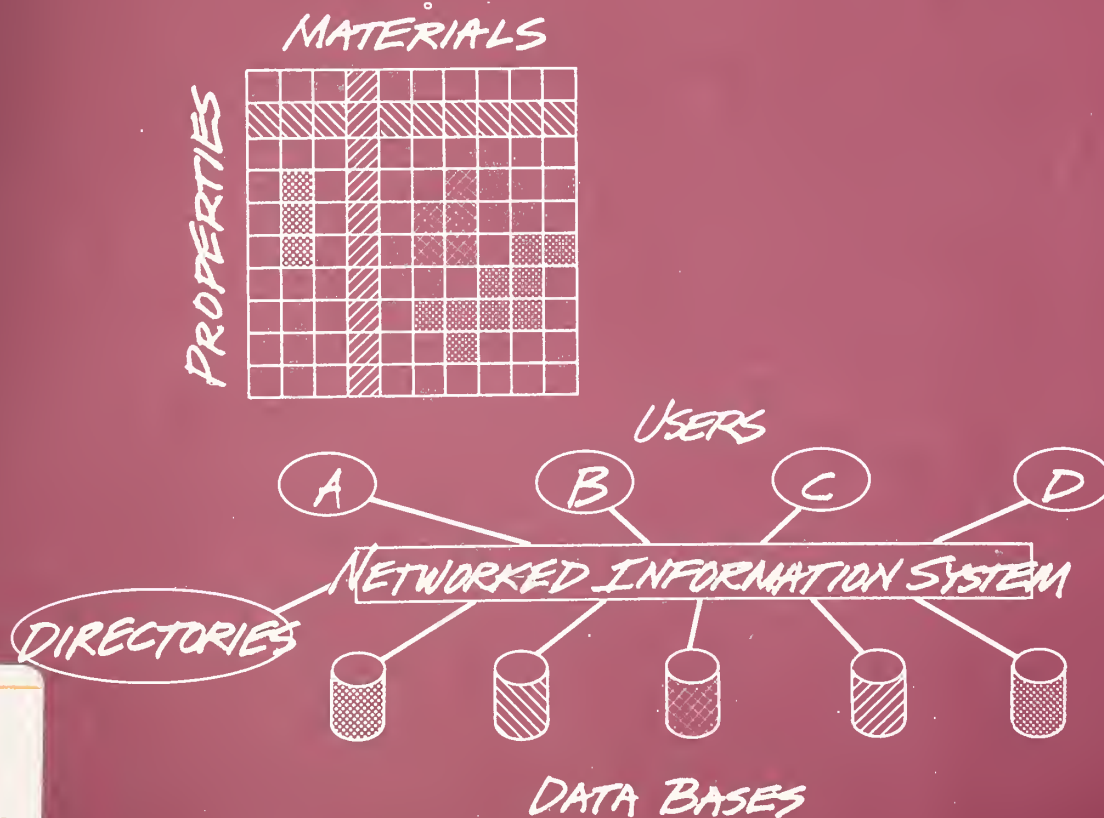

QC  
100  
.U57  
No. 702  
1985  
C. 2



The National Bureau of Standards<sup>1</sup> was established by an act of Congress on March 3, 1901. The Bureau's overall goal is to strengthen and advance the nation's science and technology and facilitate their effective application for public benefit. To this end, the Bureau conducts research and provides: (1) a basis for the nation's physical measurement system, (2) scientific and technological services for industry and government, (3) a technical basis for equity in trade, and (4) technical services to promote public safety. The Bureau's technical work is performed by the National Measurement Laboratory, the National Engineering Laboratory, the Institute for Computer Sciences and Technology, and the Institute for Materials Science and Engineering.

### *The National Measurement Laboratory*

Provides the national system of physical and chemical measurement; coordinates the system with measurement systems of other nations and furnishes essential services leading to accurate and uniform physical and chemical measurement throughout the Nation's scientific community, industry, and commerce; provides advisory and research services to other Government agencies; conducts physical and chemical research; develops, produces, and distributes Standard Reference Materials; and provides calibration services. The Laboratory consists of the following centers:

- Basic Standards<sup>2</sup>
- Radiation Research
- Chemical Physics
- Analytical Chemistry

### *The National Engineering Laboratory*

Provides technology and technical services to the public and private sectors to address national needs and to solve national problems; conducts research in engineering and applied science in support of these efforts; builds and maintains competence in the necessary disciplines required to carry out this research and technical service; develops engineering data and measurement capabilities; provides engineering measurement traceability services; develops test methods and proposes engineering standards and code changes; develops and proposes new engineering practices; and develops and improves mechanisms to transfer results of its research to the ultimate user. The Laboratory consists of the following centers:

- Applied Mathematics
- Electronics and Electrical Engineering<sup>2</sup>
- Manufacturing Engineering
- Building Technology
- Fire Research
- Chemical Engineering<sup>2</sup>

### *The Institute for Computer Sciences and Technology*

Conducts research and provides scientific and technical services to aid Federal agencies in the selection, acquisition, application, and use of computer technology to improve effectiveness and economy in Government operations in accordance with Public Law 89-306 (40 U.S.C. 759), relevant Executive Orders, and other directives; carries out this mission by managing the Federal Information Processing Standards Program, developing Federal ADP standards guidelines, and managing Federal participation in ADP voluntary standardization activities; provides scientific and technological advisory services and assistance to Federal agencies; and provides the technical foundation for computer-related policies of the Federal Government. The Institute consists of the following centers:

- Programming Science and Technology
- Computer Systems Engineering

### *The Institute for Materials Science and Engineering*

Conducts research and provides measurements, data, standards, reference materials, quantitative understanding and other technical information fundamental to the processing, structure, properties and performance of materials; addresses the scientific basis for new advanced materials technologies; plans research around cross-country scientific themes such as nondestructive evaluation and phase diagram development; oversees Bureau-wide technical programs in nuclear reactor radiation research and nondestructive evaluation; and broadly disseminates generic technical information resulting from its programs. The Institute consists of the following Divisions:

- Inorganic Materials
- Fracture and Deformation<sup>3</sup>
- Polymers
- Metallurgy
- Reactor Radiation

<sup>1</sup>Headquarters and Laboratories at Gaithersburg, MD, unless otherwise noted; mailing address Gaithersburg, MD 20899.

<sup>2</sup>Some divisions within the center are located at Boulder, CO 80303.

<sup>3</sup>Located at Boulder, CO, with some elements at Gaithersburg, MD.

*NBS Special Publication 702*

---

*Standards and Metadata  
Requirements for Computerization of  
Selected Mechanical Properties of  
Metallic Materials*

---

Jack H. Westbrook  
General Electric Corporation

Work Sponsored by:

National Bureau of Standards and  
U.S. Army DARCOM

August 1985



**U.S. Department of Commerce**  
Malcolm Baldrige, Secretary  
National Bureau of Standards  
Ernest Ambler, Director

---

Library of Congress  
Catalog Card Number 85-600585  
National Bureau of Standards  
Special Publication 702  
Natl. Bur. Stand. (U.S.),  
Spec. Publ. 702,  
47 pages (Aug. 1985)  
CODEN: XNBSAV

U.S. Government Printing Office  
Washington: 1985

For sale by the Superintendent  
of Documents,  
U.S. Government Printing Office,  
Washington, DC 20402

## FOREWORD

Over the past few years, a number of activities have been started with the ultimate goal being to develop easy-to-use materials data systems which contain a large amount of data on a wide variety of materials. In 1982, a meeting of experts on materials, data systems, and databases was held in Fairfield Glade, Tennessee. The report of that workshop—*Computerized Materials Data Systems*—concluded that no major barriers existed to developing such systems and recommended that work begin immediately.

Since then, The Metal Properties Council, Inc. and the National Bureau of Standards have taken many steps toward realizing the goals set forth in that report. Work has begun on building databases of evaluated data on mechanical properties and corrosion. Workshops have been held in various industries for engineers who are potential users to determine their precise needs for materials data. The Metal Properties Council has established the National Materials Property Data Network, Inc. as the focal point for industrial involvement, and that group has already raised substantial industry support. A project to build a demonstration system has started under the sponsorship of the National Bureau of Standards and the Office of Scientific and Technical Information of the Department of Energy.

One of the major areas of concern are the materials data themselves since most mechanical and corrosion properties are not intrinsic but rather result from standard tests which over the years have been correlated to service performance. Questions have been raised concerning the adequacy of these tests with respect to computer storage and delivery of the data. Many tests have several variations, and often the tests themselves change in time. Consequently, combining data generated by two similar but not equivalent test methods may or may not be valid engineering practice.

This report is an attempt to identify some of the issues and problems relating to standards of mechanical properties of metallic materials. The work was sponsored by the Office of Standard Reference Data of NBS using funds provided by the U.S. Army DARCOM. It is anticipated that the discussion and recommendations given here, while representing one view, may also be used to generate action within the engineering standards community to look into the coming age of computerized materials data and to address the associated issues.

David R. Lide, Jr.  
Director  
Standard Reference Data

## EXECUTIVE SUMMARY

To assist in building a computerized information system on the engineering properties of materials, the standards and metadata requirements for a representative group of mechanical property categories are considered. These categories include: tensile behavior, hardness numbers, notch-bar impact test parameters and fatigue properties. For each property group, definitions of terms, synonyms (and non-synonyms), standard test methods, standards for reporting data, precision and accuracy, and correlations of properties are addressed.

The principal findings and recommendations are as follows. Existing test methods are generally adequate for the properties considered but better standards are needed for data reporting. Appraisal of materials variability and testing machine variability would be assisted by access to standard reference materials, certified as to their mechanical properties. All properties considered for inclusion in a computerized system can be categorized as: parameters for direct search, parameters retrievable with extraction of all data stored for a given material, and parameters which are derived from an analytical representation of experimental data. Drafting of some general standards on computerized file structures and metadata files suitable for the engineering field is advised.

### Recommendations

The recommendations set forth below apply strictly only to the specific mechanical properties examined in the study. Many, however, are broadly generalizable to all standards and metadata requirements for computerized data on engineering properties of metallic materials.

#### Testing Standards

1. Adequate ASTM standards exist for the several mechanical property groups examined, except for fatigue. Here standards need to be issued for rotational fatigue, plane bending, and torsion, or one of the existing foreign standards should be endorsed.
2. ASTM standards are often inadequate in the extent to which information to be reported is specified. Since computerized data systems have enhanced capability for both merger and intercomparison of separate data sets, it is imperative that testing and reporting standards be improved so as to permit such treatments of the data. It is suggested that ASTM E 21.11-79 be used as a starting point for reporting data.
3. Wherever data obtained from foreign tests are to be included in an information system, careful comparison needs to be made of standardized test methods to assess the possibility for interconversion.
4. There is a need for a complete compilation of all definitions used in ASTM standards on mechanical property testing including resolution of conflicting definitions. Such a list would allow more uniform nomenclature in databases as they are built.

#### Computerization Standards

ASTM should consider the advisability of drafting some general standards on computerized file structures, metadata files, etc. These could then be made particular by existing committees focused on individual materials or test methods. An example of such standards is the classification of different classes of mechanical property data included in databases. One possible scheme shown below would distinguish three broad classes of these data based on how engineers might search databases.

#### Classes of Data

Three broad classes of properties data may be distinguished:

1. *Parameters for Direct Search*—examples include yield strength, fatigue strength at N cycles, Charpy V-notch impact strength, elastic modulus, etc.
2. *Parameters Retrievable with Extraction of all Data Stored for a Given Material*—examples include hardness values, tensile elongation, reduction in area, etc. In other words, these are data which it might

be desirable to the user to know but which would rarely if ever be involved in a search for materials exhibiting a specified profile of properties.

3. *Parameters Derived from an Analytical Representation of Experimental Data*—examples include impact transition temperature, Ramberg-Osgood exponent, fatigue life parameters, etc. The concept here is that the database manager may choose to store the pertinent raw experimental data in the file and then subject these to a certain type of analysis to yield the derived parameters. The user of the database may be permitted to access and search upon only the derived parameters or, alternatively, to retrieve a whole data set for a particular material together with its analytical representation but not individual data points.

In any specific computerized system, allocation of individual parameters to the above three data classes depends in part on the database management system being used and in part on user preference decisions built into the information systems design. However, ASTM may wish to differentiate in their standards the data reporting requirements according to these three classes.

### Other Recommendations

*Specific Database Comparisons*—The observations and conclusions reported here result from a broad reconnaissance of the general literature on mechanical properties. Once work on an integrated data system has started and specific candidate databases have been identified, their terminology, referenced test methods, etc., need to be checked against the dictionaries, cross-references, and other assists advocated here.

*Standard Reference Materials*—A great need exists for standard reference materials for the several mechanical properties considered here. None exist within the national NBS collection and none anywhere for tensile and fatigue behavior. Only for hardness and impact data have standard reference materials been privately developed.

*Extension of this Study*—Implementation of any broad materials information system covering several overlapping data compilations will require extension of the above pattern of information and analysis, not only in the remaining important mechanical behaviors—torsion, compression, fracture (toughness and crack growth rate), creep and stress rupture, stress corrosion and corrosion-fatigue—but also in other property areas—electrical, magnetic, processibility, safety and health, etc. However, because of the relative newness of certain of these areas, the multiplicity of terms and test methods, coupled with the paucity of standards, will make the extension of the study more difficult. Yet the results of such a study could provide the basis for a standard covering presentation of engineering property data for any purpose whatsoever.

# CONTENTS

	Page
Foreword .....	iii
Executive Summary and Recommendations .....	iv
Introduction .....	1
Chapter 1 – Tensile Behavior .....	4
Chapter 2 – Hardness Numbers .....	16
Chapter 3 – Notch Bar Impact Test Parameters .....	23
Chapter 4 – Fatigue Properties .....	30

## List of Figures

	Page
<b>Chapter 1</b>	
Figure 1. Relationship of stress-strain curve to kinetic modulus .....	4
Figure 2. Stress-strain relationship showing 0.1% and 0.2% proof stress, and proportional limit .....	5
Figure 3. Stress-strain diagram for determination of yield strength by the offset method.	7
Figure 4. Stress-strain diagram for determination of yield strength by the extension-under-load method .....	7
Figure 5. Tensile strength versus hardness for 4340 and 8630 steel.....	13
<b>Chapter 2</b>	
Figure 1. Correlation lines for metals and ionic crystals relating hardness numbers and yield stresses .....	20
Figure 2. Correlation of hardnesses and elastic moduli for pure fcc metals and covalent crystals .....	21
Figure 3. Vickers hardness softening coefficient (B) for metals (including low-expansion alloy, Nilo 36) and thermal coefficient of expansion.....	21
<b>Chapter 3</b>	
Figure 1. Dimensional details of Izod and Charpy test specimens as called for in ASTM E23-82.....	23
Figure 2. Schematic of the hyperbolic tangent function representing the temperature dependence of impact toughness .....	24
Figure 3. Reproducibility of impact test results derived from extensive testing of AMMRC.....	27
Figure 4. Variation in impact behavior of a steel tempered to various strength levels ...	28
Figure 5. Correlation between fracture toughness $K_{Ic}$ and Charpy V-notch-impact strength in the upper shelf region .....	28



	Page
<b>Chapter 4</b>	
Figure 1. Typical fatigue loadings and definitions of stress terms . . . . .	31
Figure 2. Typical constant-life fatigue diagram for heat-treated AISI 4340 alloy steel (bar), $F_{tu} = 125$ ksi . . . . .	33
Figure 3. Cyclic stress-strain curve drawn through stable loop tips . . . . .	34
Figure 4. Cyclic stress-plastic strain plot, 1020 H. R. Steel . . . . .	34
Figure 5. Strain amplitude versus reversals to failure, 1020 H. R. Steel . . . . .	34
Figure 6. S-N diagram retrieved in the condition of smooth bar specimen, S35C alloy in JIS Standard; $\sigma_y = 20\text{--}50$ kg/mm <sup>2</sup> , in air, temperature = 0–30°, mean stress $\sigma_m = 0$ , and rotating bending or axial loading . . . . .	36
Figure 7. Distribution of fatigue lifetimes. Results of simulated service tests of front suspension torsion bar springs of 5260H steel. Size of hexagonal bar section was 32 mm (1.25 in). Mean service life 134,000 cycles; standard deviation 37,000 cycles; coefficient of variation 0.28 . . . . .	38
Figure 8. Relation of tensile strength and fatigue limit retrieved in the condition of carbon steel, smooth bar specimen, in air, temperature = 0–30°, and rotating bending . . . . .	38

### List of Tables

	Page
<b>Chapter 1</b>	
Table 1. Recommended values for rounding test data . . . . .	12
<b>Chapter 2</b>	
Table 1. Rockwell test scales, indenting conditions, and typical applications . . . . .	18
Table 2. Standard Brinell Test Loads . . . . .	18
Table 3. Repeatability of the Rockwell hardness test . . . . .	19
Table 4. Repeatability of the Vickers hardness test . . . . .	19
<b>Chapter 4</b>	
Table 1. Coefficients of variation experienced in testing for mechanical properties . . . . .	37

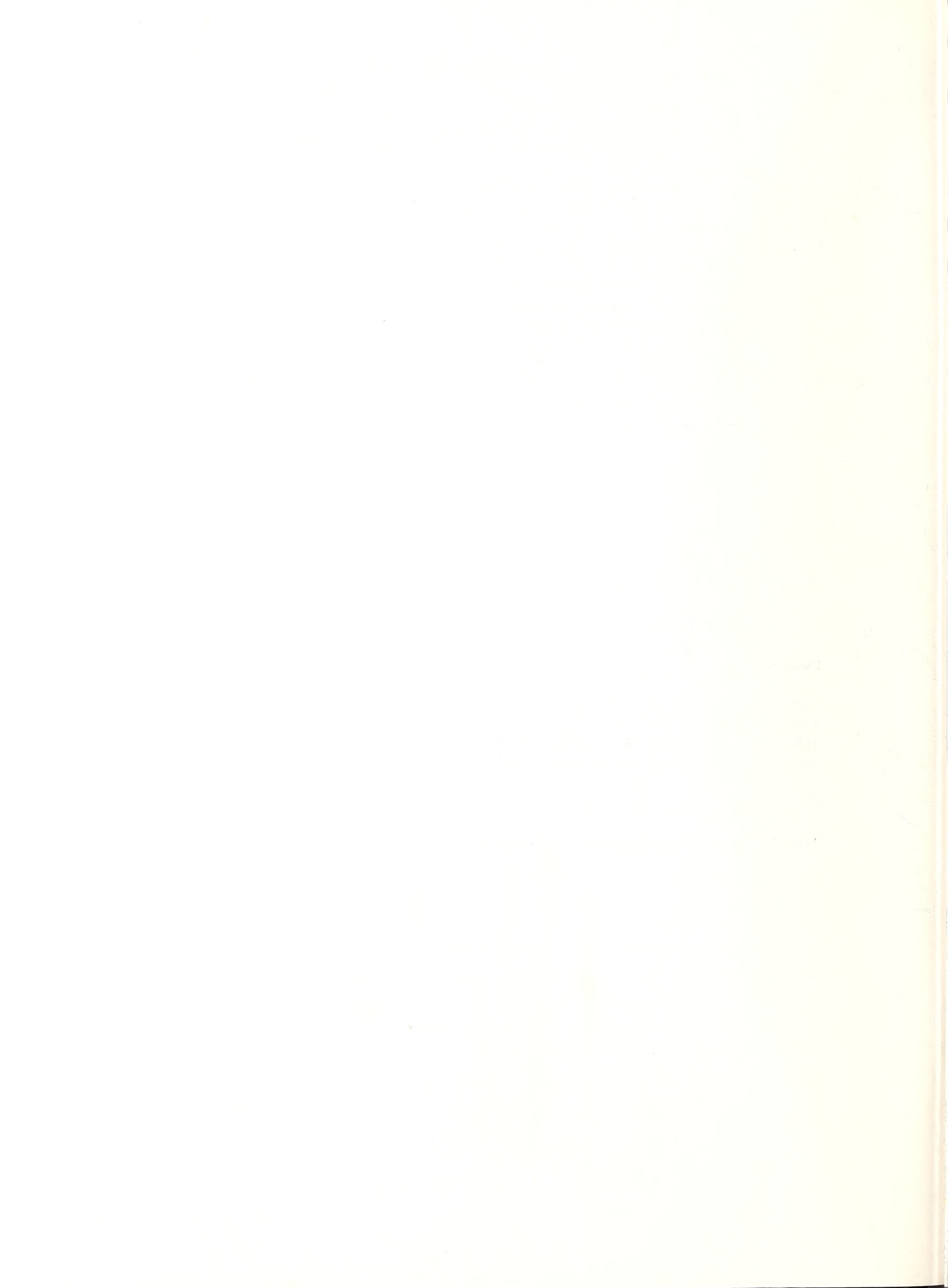

# INTRODUCTION

Current thinking on building an effective computerized information system covering the engineering properties of materials envisions the merger or electronic linkage (networking) of several existing machine-readable databases [1,2]\*. By a network system we understand a system of inter-connected, independent, machine-readable databases accessed by the user via a so-called "gateway" computer.<sup>†</sup> The gateway connects the user to that database or databases which best answers his query; performs search, retrieval and display functions; and offers a modest variety of post-processing operations—graphics, statistical analysis, re-formatting, etc. In order that the system appear to the user as a virtually integrated single database it is essential that transparent means be implanted to assure the interconvertibility of all material and property descriptors. The need for "translation" of descriptors and interpretation of data values goes beyond the requirements implied by any particular set of independent databases. Study of the materials/properties coverage offered by any chosen set of candidate databases would undoubtedly disclose both broad gaps in certain parts of the materials/properties matrix and isolated omissions of data for certain key properties of materials which would have to be filled by extraction from the literature [3]. Thus, an even broader array of descriptors would be introduced which would require conversion to the standard terms of the computerized system.

Whichever aspect of the development of a computerized materials properties system is considered—merger of separate databases, concurrent use of several in a linked system, or incorporation of new, additional data, there are numerous problems of definition to be addressed before the integration of data of different origin can be made intelligible and effective for the user of the system. The generic term to cover all descriptive, cross-reference, or indexed forms of data needed to identify and define a specific set of data values in a computerized database is "metadata" [4-6].

Although the range of metadata required for materials and properties in a full-blown system is quite large, this study confines attention to certain mechanical properties of metals with the thought that the findings and recommendations arrived at would not only have value in themselves but also that collectively they might serve as a model for what is needed in other materials/property areas.

Mechanical properties of metallic materials have been identified in several studies [1,2] as the first and most important component of any comprehensive system of computerized engineering materials information. Existing machine-readable files of mechanical properties, not to mention the general literature, are not readily integrable because of their use of different terminology, definitions, units, test methods, etc. What is needed then is a system support dictionary which will show, wherever possible, the *synonyms*—words, phrases, or symbols—for each pertinent property. Furthermore by providing, as one of the "helps" in a network, a *definition* of each important term, a system would aid the user in the interpretation of data and in ascertaining the degree of incongruency of non-synonymous terms. Provision of exemplary sets of such definitions and synonym lists are an important output of this study. It was further anticipated that other major results of this study would be:

- encouragement of full reporting of all the necessary metadata for data recording and
- strengthening of the use of standard methods of materials testing and data analysis.

There are three main uses to be made of metadata of this type within a computerized data system:

1. The availability in the system of a synonym dictionary which will be used, transparent to the user, to "translate" user terms (such as property designations and units), to standardized internal system terms during search and retrieval.
2. The availability of a series of content directories covering such areas as terms, test methods, and property titles for user viewing purposes, either prior to or during search and retrieval activities.
3. The availability of a "HELP" thesaurus, including term definitions, relationships, etc., with associated explanatory text as covered in this report, to support the user in the intellectual aspects of accessing and utilizing the system of databases.

The specific task statement for this study included:

1. Develop definitions of nomenclature and properties, referenced wherever possible to existing standards.

---

\*Figures in brackets indicate literature references.

<sup>†</sup>This concept embraces both direct access to the network itself as well as down-loading any arbitrarily customized subset(s) of the whole for use "off-line" in a personal computer.

2. Recommend new standards for reporting data.
3. Consider the desirability of recommending standard reference materials for mechanical property determination.
4. Compile a dictionary of synonyms and cross-reference terms to mechanical properties in order to facilitate entry to an information system.
5. Recommend standard test methods
  - a. where none satisfactory are found, define the need
  - b. where rigorous tests are impractical, because of time or cost limitations, recommend correlative tests.
6. Distinguish, where appropriate, between properties which should be searchable vs. those which are merely retrievable with the entire record for a given material.

The organization of this report is as follows. The specific mechanical property categories considered include:

- tensile behavior
- hardness numbers
- notch bar impact test parameters
- fatigue properties

These property categories are representative of the types of mechanical property tests most commonly conducted and of the property parameters most frequently recorded. The tensile test shows the response of a material (usually as a cylindrical or flat sheet specimen) to uniaxial tensile loading. Not only are many service parts loaded essentially in pure tension but experience has shown that results of the tensile test may be used to a degree to predict behaviors under more complex circumstances. Hardness numbers are derived from indenting a material with an indenter of known geometry under a specified load. This crude but quick and inexpensive test is very widely used, especially as an inspection tool, and often correlates well with other mechanical properties. Notch bar impact tests measure the ability of a material to absorb energy under a rapidly applied load and convey information not imparted by the tensile parameters. Fatigue tests measure the resistance of a material to repeated application of stress or strain, a characteristic important in many cases of moving machinery, for example. Each of the above categories is considered in a separate chapter with individual referencing, figure numbers, etc., so as to facilitate later extension of the work to other mechanical property groups in a possible supplement to the study. It is not the intent to prepare, at this time, a concise treatise on *all* mechanical properties but rather to present a reconnaissance of the problems of database compatibility and "user friendliness" in computer networking in that subject area, with only sufficient general background as to make the report intelligible on its own.

Clearly there is much more work like this to be done. Other property areas—even some closely related to those reported on here such as fracture toughness and crack growth rates—are equally or even more important for similar examination. Even collectively, what has been done to date represents only a generalized model approach. In planning the interconnection of two or more specific databases one must consider what particular terms, test methods, and derived parameters still lie outside the definitions and equivalency lists presented here. Furthermore, designation of a particular application area or user community for the system might modify the scope of mechanical property coverage.

Finally, despite the above limitations, the extent of the study has been such that some broad recommendations can be offered. These are summarized in the executive summary at the beginning.

## References

- [1] Graham, J. A., "The Metal Properties Council Activities on a National Materials Property Data Network," in "An On-Line Materials Property Base", J. A. Graham, ed. (American Society of Mechanical Engineers, New York, 1983), pp. 1-14.
- [2] Westbrook, J. H., and Rumble, J. R., eds. "Computerized Materials Data Systems," Nov. 1982, available from OSRD, National Bureau of Standards, Gaithersburg, MD 20899.
- [3] Westbrook, J. H., "Extraction and Compilation of Numerical and Factual Data," AGARD Lecture Series #130 *Development and Use of Numerical and Factual Databases*, Neuilly sur Seine, France (1984).

- [4] Date, C. J. "Introduction to Database Systems", 3d ed. Addison-Wesley, Reading, MA (1981).
- [5] McCarthy, J. L., "Metadata Management for Large Statistical Databases," *Proc. 8th Int. Conf. on Very Large Databases*, Mexico City (1982) 234-243.
- [6] Westbrook, J. H., "Some Considerations in the Design of Properties Files for a Computerized Materials Information System" *Proc. 9th Int. CODATA Conf.*, Jerusalem, Israel, June 1984 (to be published).

# Chapter 1

## TENSILE BEHAVIOR

### Introduction

The behavior of a material when subjected to uniaxial tensile loading is perhaps the most common and most informative of mechanical property tests. Basically, the deformation of the material is observed as it is incrementally stressed through the elastic and plastic regions to ultimate failure. From the specimen dimensions and the load-deformation response, a number of different parameters may be derived (yield strength, elongation, ultimate strength, etc.) which have been adopted as descriptive of the material behavior. Such data are used for comparison of materials, for alloy development, for quality control, and for some aspects of design. Definitions are provided in ASTM Standard E6-81, [1] extracts from which are shown below.

### Definitions ([1] except as noted)

Figures 1 to 4 will aid in the interpretation of these definitions and in appreciating the distinction between synonyms and non-synonymous terms to be discussed subsequently.

*elastic limit* [ $FL^{-2}$ ]<sup>1</sup>—the greatest stress which a material is capable of sustaining without any permanent strain remaining upon complete release of the stress.

ASTM Note—Due to practical consideration in determining the elastic limit, measurements of strain, using a small load rather than zero load, are usually taken as the initial and final reference.

*elongation*—the increase in gage length (Note 1) of a tension test specimen, usually expressed as percentage of the original gage length.

ASTM Note 1—The increase in gage length may be determined either *at* or *after* fracture, as specified for the material under test.

ASTM Note 2—The term elongation, when applied to metals, generally means measurement *after* fracture; when applied to plastics and elastomers, measurement *at* fracture. Such interpretation is usually applicable to values of elongation reported in the literature when no further qualification is given.

ASTM Note 3—In reporting values of elongation the gage length shall be stated.

*modulus of elasticity* [ $FL^{-2}$ ]<sup>1</sup>—the ratio of stress to corresponding strain below the proportional limit. (Author's note: for other types of modulus, secant modulus, tangent modulus, etc., see fig. 1)

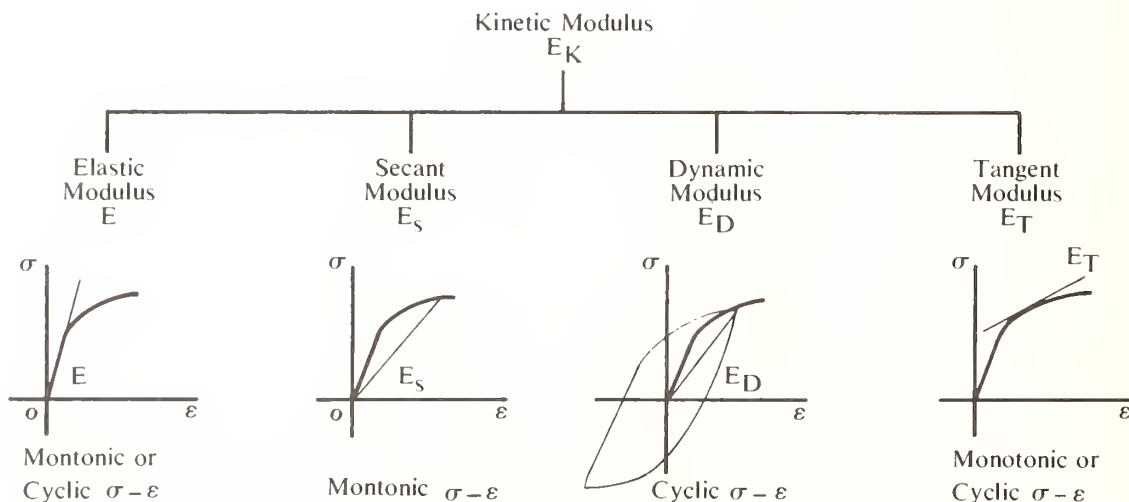

Figure 1. Relationship of stress-strain curve to kinetic modulus (after Kasper et al., SAE Tech Paper 790003 (1979)).

<sup>1</sup>Dimensional analysis; F=force, L=lineal dimension

*Poisson's ratio*—the absolute value of the ratio of transverse strain to the corresponding axial strain resulting from uniformly distributed axial stress below the proportional limit of the material.

ASTM Note 1—Above the proportional limit, the ratio of transverse strain to axial strain will depend on the average stress and on the stress range for which it is measured and, hence, should not be regarded as Poisson's ratio. If this ratio is reported, nevertheless, as a value of "Poisson's ratio" for stresses beyond the proportional limit, the range of stress should be stated.

ASTM Note 2—Poisson's ratio will have more than one value if the material is not isotropic.

*proof stress* [ $FL^{-2}$ ]<sup>2</sup>—the stress that will cause a specified small permanent set in a material. (From ASM Handbook, 9th ed.) (See fig. 2.)

*proportional limit* [ $FL^{-2}$ ]<sup>2</sup>—the greatest stress which a material is capable of sustaining without any deviation from proportionality of stress to strain (Hooke's law). (See fig. 2.)

ASTM Note—Many experiments have shown that values observed for the proportional limit vary greatly with the sensitivity and accuracy of the testing equipment, eccentricity of loading, the scale to which the stress-strain diagram is plotted, and other factors. When determination of proportional limit is required, the procedure and the sensitivity of the test equipment should be specified.

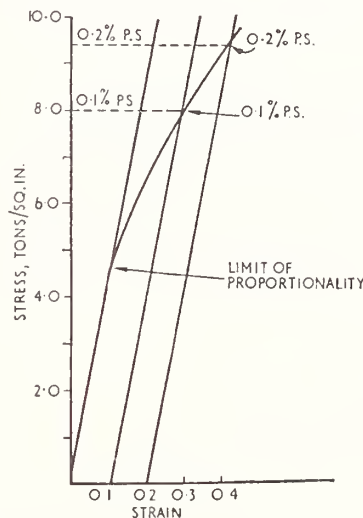

Figure 2. Stress-strain relationship showing 0.1% and 0.2% proof stress, and proportional limit (after Merriman, "Concise Encyclopedia of Metallurgy" McDonald and Evans (1965)).

*reduction of area*—the difference between the original cross-sectional area of a tension test specimen and the area of its smallest cross section (Note 1). The reduction of area is usually expressed as a percentage of the original cross-sectional area of the specimen.

ASTM Note 1—The smallest cross section may be measured at or after fracture as specified for the material under test.

ASTM Note 2—The term reduction of area when applied to metals generally means measurement after fracture; when applied to plastics and elastomers, measurement at fracture. Such interpretation is usually applicable to values for reduction of area reported in the literature when no further qualification is given.

*strain-hardening exponent* ( $n$ )—the exponent in the empirical relationship between true stress and true strain,  $\sigma = K\epsilon^n$ . It is computed as the slope of the assumed linear relationship between logarithm true stress and logarithm true strain.<sup>2</sup> [2]

<sup>2</sup>True stress is load divided by instantaneous cross-sectional area [prior to necking,  $\sigma = S(1 + e)$ ] and true strain is the natural logarithm of the ratio of the length at the moment of observation to the original gage length, [ $\epsilon = \ln(1 + e)$ ].

*strain rate exponent*<sup>3</sup> (*m*)—the exponent in the empirical relationship between true stress and strain rate,  $\sigma = K\dot{\epsilon}^m$ , taken at constant strain,  $\epsilon$ . It is computed as the slope of the assumed linear relationship between logarithm true stress and logarithm true strain rate.

*tensile strength* [ $FL^{-2}$ ]<sup>2</sup>—the maximum tensile stress which a material is capable of sustaining. Tensile strength is calculated from the maximum load during a tension test carried to rupture and the original cross-sectional area of the specimen.

*true fracture stress* [ $FL^{-2}$ ]<sup>2</sup>—the true normal stress on the minimum cross-sectional area at the beginning of fracture. (Author's note: This value must be corrected for the effect of triaxial stress once necking has begun. One such correction has been suggested by Bridgman.)

ASTM Note—This term usually applies to tension tests of unnotched specimens.

*yield point* [ $FL^{-2}$ ]<sup>2</sup>—the first stress in a material, less than the maximum attainable stress, at which an increase in strain occurs without an increase in stress.

ASTM Note—It should be noted that only materials that exhibit the unique phenomenon of yielding have a "yield point."

*yield strength* [ $FL^{-2}$ ]<sup>2</sup>—the stress at which a material exhibits a specified limiting deviation from the proportionality of stress to strain. The deviation is expressed in terms of strain.

ASTM Note—It is customary to determine yield strength by:

- (a) Offset Method (usually a strain of 0.2% is specified), (see fig. 3)
- (b) Total-Extension-Under-Load Method (see fig. 4; usually a strain of 0.5% is specified although other values of strain may be used). An equation for calculating strain is:

$$x = [Y/E + \text{specified offset (strain)}] \times 100$$

where:

*x* = limiting strain, in percent,

*Y* = specified yield strength, in psi, and

*E* = nominal modulus of elasticity of the material, in psi.

(This strain, *x*, is multiplied by the gage length to determine the total extension under load.)

Whenever yield strength is specified, the method of test must be stated along with the percent offset or the total strain under load. The values obtained by the two methods may differ.

---

<sup>3</sup>Not defined by ASTM; composed by author.



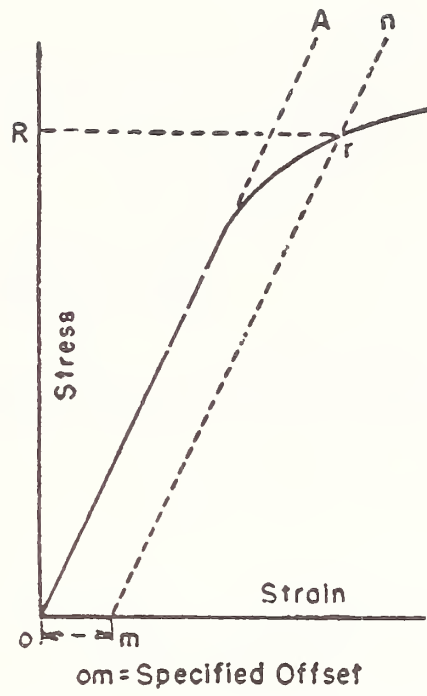

Figure 3. Stress-strain diagram for determination of yield strength by the offset method (ASTM A-370-77).

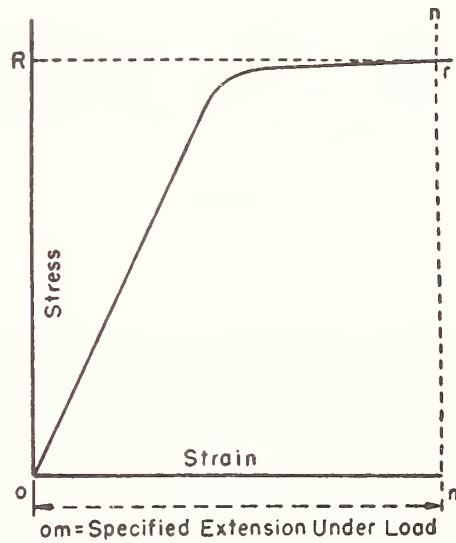

Figure 4. Stress-strain diagram for determination of yield strength by the extension-under-load method (ASTM A-370-77).

## Data Analysis

Where it is desired to have a more complete analytical description of tensile behavior, other methods can be employed. For engineering stress-strain properties beyond yielding, the so-called Ramberg-Osgood equation [3]<sup>4</sup> is often used:

$$e = S/E + 0.002 (S/S_y)^r \quad (1)$$

where  $e$  = strain  
 $S$  = stress  
 $E$  = elastic modulus

$S_y$  = 0.2% offset yield stress  
 $r$  = Ramberg-Osgood exponent<sup>5</sup>

Analytical methods for determination of  $r$  are discussed in Mil Handbook 5 [4].

In the plastic region, true stress and true strain are related by an empirical expression

$$\sigma = \sigma_0 \epsilon^n \quad (2)$$

where  $\sigma$  = true stress  
 $\sigma_0$  = a constant  
 $\epsilon$  = true strain  
 $n$  = strain hardening exponent

Analogously, engineering stress-strain in the plastic region may be represented by a power law, up to the point of maximum load

$$S = A \epsilon^p \quad (3)$$

where  $A$  = strain hardening coefficient  
 $p$  = strain hardening exponent

The functional equivalence of eq (3) and eq (1) is readily seen by algebraic manipulation.

Even when no attempt is made to record the full stress-strain curve, notation is frequently made of the strain hardening exponent  $n$  or  $p$ . Likewise strain rate sensitivity is measured by the exponent,  $m$ , in the expression

$$\sigma = K \dot{\epsilon}^m \quad (4)$$

where  $\dot{\epsilon}$  = strain rate  
 $K$  = constant

By modification of the test specimen or apparatus, it is possible to conduct a tensile test under conditions of plane strain to which many practical sheet forming operations approximate. Such tests, as described by Sang and Nishikawa [5] can yield both the plane strain limit strain and the ductility in plane strain.

It should be noted that, in analysis of experimental data according to equations such as (1) to (4) involving exponentials, least squares treatment of linear relations in a log-log plot biases the results due to the fact that equal weight is given to the least accurate portion of the records, the low values of strain or strain rate.

## Synonyms

In design of computerized systems it is important, both in the loading of data from diverse sources as well as to accommodate the varied terminology employed by different users, that the system be provided with thesauri which allow automatic translation of terms frequently encountered. To this end we list here synonymous terms for each of the major parameters associated with each class of properties. Also noted are other terms of possible relevance which should not be confused with the parameter in question.

<sup>4</sup>Other functional representations have also been proposed, for example:

Voce  $\sigma = a + (b - a)[1 - \exp(-c\epsilon)]$

and Swift  $\sigma = c(a + \epsilon)^n$

where  $a, b, c$  and  $n$  are constants and  $\epsilon$  is true strain.

<sup>5</sup> $n$  is often used but is replaced here by  $r$  to avoid confusion with the strain hardening exponent  $n$ .

**Synonymous Terms**

*Yield Strength*

Yield  
Y.S.  
Tensile yield  
Proof stress  
P.S.  
 $F_{ty}$

*Tensile Strength*

Ultimate strength  
U.T.S.  
U.S.  
Tensile strength  
Ultimate tensile strength  
Maximum tensile stress  
Tenacity  
Tensile ultimate  
 $F_{tu}$

*True Fracture Stress*

Breaking strength  
Breaking stress  
Fracture strength  
Fracture stress

*Modulus of Elasticity*

Elastic modulus  
Young's modulus  
Modulus of extensibility  
Stretch modulus  
Monotonic modulus  
Static modulus  
Tensile modulus  
Coefficient of elasticity  
E

*Elongation*

Elongation at break  
Elongation at fracture  
Ductility  
Tensile ductility  
Tensile elongation  
e

*Reduction of Area*

R.A.  
Area reduction  
Reduction in area

*Poisson's Ratio*

Poisson's ratio  
Poisson's number

*Proportional Limit*

Limit of proportionality

*Elastic Limit*

**Not Synonymous**

Yield point  
Upper yield  
Lower yield  
Flow stress

Rupture strength  
Modulus of rupture  
Maximum fiber stress

Rupture strength  
Modulus of rupture  
Rupture modulus

Tangent modulus  
Secant modulus  
Chord modulus  
Initial tangent modulus  
Dynamic modulus  
Kinetic modulus

True fracture ductility

Plastic strain ratio

Elastic limit

Proportional limit

### *Strain Rate Exponent*

Strain rate sensitivity  
m

### *Strain Hardening Exponent*

n

## Standard Test Methods

The tensile test is based upon well-established test methods, both because of its long history of use and its wide application. The basic test method for tension testing of metallic materials is ASTM E8-82 [6]. This document is supplemented by the following ASTM test methods:

Those specific to various material classes:

		Ref.
Steel	A370	[7]
Copper alloys	B598	[8]
Aluminum and magnesium alloys	B557	[9]
Aluminum and magnesium alloys (metric)	B557M	[10]

Those specific to form:

Foil	E345	[11]
Fasteners	F606	[12]
Wire	F113, F219	[13,14]

Those specific to particular test conditions:

Sharp notch sheet	E338	[15]
Sharp notch cylindrical bar	E602	[16]
Elevated temperature	E21	[17]

Those specific to particular parameters:

Plastic strain ratio	E517	[18]
Poisson's ratio	E132	[19]
Young's modulus	E231	[20]
Young's modulus, tangent modulus and chord modulus	E111	[21]
Strain hardening exponent	E646	[2]

These procedural standards provide for testing of foil, sheet, plate, wire and round specimens in both standard and subsizes. A point of importance is that for the common cylindrical test bars the gage length to diameter ratio needs be maintained at 4:1 if elongation values are to be comparable. It should be noted further that European and Japanese practice is for a 5:1 ratio, which has been adopted for ISO standards and may become future ASTM practice. One way of estimating 5D elongation from 4D data is described below under *correlations*.

## Standards for Reporting Data

In order that tensile data be fully assessable they must be completely documented; that is, it is necessary that results be accompanied by a full description of material, specimen, test method, and data reduction techniques. Curiously, despite all the detail provided on recommended test methods in ASTM standards for tensile testing, most such standards are silent or carry only implied guidance as to reporting of data. A notable

exception is that on elevated temperature tensile testing [17], the pertinent section of which is quoted in full below because of its useful detail:

## 11. *Report*

11.1 The report shall include the following:

11.1.1 Description of material tested, including method of manufacture, type and size of product, and other pertinent processing information, as well as heat treatment, microstructure, and chemical composition.

11.1.2 Specimen dimensions, including cross-sectional dimensions, fillet radius, length of reduced section, adjusted length of reduced section (if used), type of end connection, and whether machined, partially machined, or as cast.

11.1.3 Temperature of test.

11.1.4 Strain rate during yielding and strain rate after yielding.

11.1.5 Yield strength, if required, and drop-of-beam yield point if such a yield point occurs.

11.1.5.1 When one or more values of yield strength are required, the amount of the offsets should be shown with the numerical values.

11.1.5.2 If the extensometer was attached to the specimen shoulders, this fact should be stated in a footnote to the values.

11.1.5.3 If an extensometer was not attached directly to the specimen, the value should be listed as approximate yield strength (offset=0.2%).

11.1.6 Tensile strength.

11.1.7 Elongation and gage length. If elongation was measured from gage marks not on the reduced section of the specimen this fact should be included in the designation of the quantity, for example "elongation from shoulder measurements" or "elongation from overall measurements." If elongation was measured from the extensometer record at fracture instead of after fracture, this should be noted.

11.1.8 Reduction of area for specimens with circular cross section.

11.1.9 Time to attain test temperature and time at temperature before testing.

11.1.10 Other special conditions, such as nonstandard atmosphere and heating methods, exceptions to required dimensional accuracy and axiality of loading, amount and duration of temperature overshoot.

11.1.11 Location and description of fracture. The description should include any defects, evidence of corrosion, and type of fracture (such as cup and cone, brittle, shear).

11.1.12 Identification of equipment used including make and capacity of testing machine, make and class of extensometer, make and size of furnace, type of temperature controller, and description of thermocouples including material, wire size, attachment, technique and shielding.

11.1.13 Name of tester and date of test.

While this text might in general be taken as a model for reporting of tensile data, it too is incomplete in some respects:

- a) orientation and location of the sample relative to the original stock (e.g. rolling direction, location in a casting, forging, etc.).
- b) surface finish in gage length (variability in test results in specimens of high strength and low ductility is particularly attributable to this factor).
- c) method of calculating or determining specific parameters (often covered in specification of test method but should appear in reporting of data where pertinent).

- d) estimated precision of the results.  
 e) recommendations for rounding of test data. An example from ASTM's steel testing standard is appropriate:

Table 1. Recommended values for rounding test data

Test Quantity	Test Data Range	Level of Rounded Value <sup>A</sup>
Yield Point, Yield Strength, Tensile Strength	up to 50 000 psi, excl.	100 psi
	50 000 to 100 000 psi, excl.	500 psi
	100 000 psi and above	1000 psi
Elongation	up to 500 MPa, excl.	1 MPa
	500 to 1000 MPa, excl.	5 MPa
	1000 MPa and above	10 MPa
Reduction of Area	0 to 10%, excl.	0.5%
	10% and above	1%

<sup>A</sup>Round test data to the nearest integral multiple of the values in this column. If the data value is exactly midway between two rounded values, round to the higher values.

## Precision and Accuracy

Despite the long history of use of tensile testing, no body of reliable test data exists to form a basis for determination of precision and accuracy. Almost every ASTM tensile testing standard comments on this point and notes that precision is "being established." No such results have been found in its literature. Standard reference materials, available for testing of tensile parameters, with certified values of their tensile data, would be very valuable in establishing accuracy and precision and in distinguishing between material variability and test variability. None such exists at present. It is recommended that the Standard Reference Materials Program at NBS investigate the feasibility of producing and certifying such standards.

## Correlations

**Hardness.** The property which is most often correlated with tensile parameters is hardness, largely because of its convenience as a quality control tool. A typical result is shown in figure 5. Unfortunately such correlations are not broadly generalizable but are restricted to a narrow family of materials with similar elastic constants, work hardening characteristics, etc. Nonetheless if this restriction be realized and accepted, the correlation can be a very useful one. A particular problem with such correlations arises with the possible absence of through-hardening in large sections of certain steels resulting in a hardness gradient. Other kinds of gradients in the thickness direction (grain size, texture, residual stresses, etc.) can also affect the correlation between tensile properties and surface indentation hardness.

**Elongation, Round to Flat.** A procedure for conversion of percent elongation in a standard cylindrical tensile bar to that for a standard flat test specimen is incorporated in ASTM standard for testing of steel [7]. This relationship is expressed as:

$$e_f = e_o(4.47 \sqrt{A/L})^2$$

where  $e_f$  = elongation in flat specimen of gage length  $L$  and cross-sectional area  $A$

$e_o$  = elongation in cylindrical specimen with 2" gage length and 0.500" diameter

$a$  = a constant characteristic of the test material

**Elongation, conversion of 4D to 5D elongations [22,23].** Two steel alloys are compared to illustrate differences in material response to testing. The numbers shown in the calculations and tables below pertain only to the specific materials used for illustration and are not to be applied elsewhere. The approach, however, is generalizable.

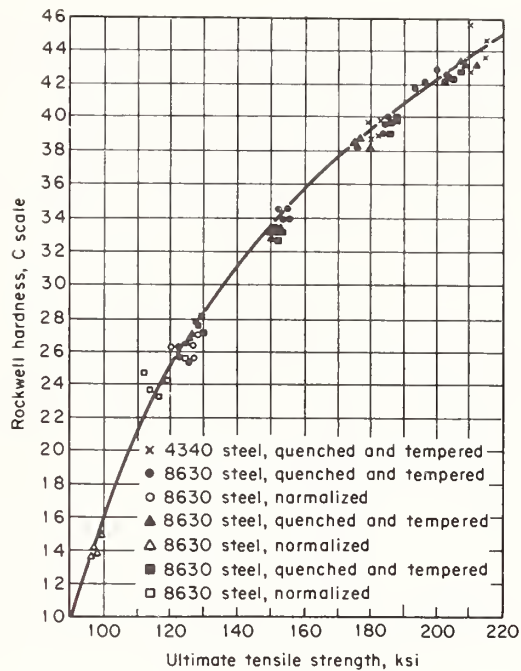

Figure 5. Tensile strength versus hardness for 4340 and 8630 steel. Reference curve plotted from ANC-5 "Strength of Aircraft Elements," Govt. Printing Office, Washington, DC (1955) p. 4.

Adjusted only for strain in the increased gage length, the values of elongation in 5D are as shown below:

	elongation %		
	Measured at 4D	Calculated for 5D from 4D	Measured at 5D
Low alloy steel	16.0	13.8	14.5
Carbon steel	31.0	27.4	27.5

It would be expected that the tensile strength, yield strength, and reduction in area would be the same for two specimens tested, if one assumes no strain in the added gage length. A more accurate assumption is that the unit strain in the added length is equal to the "uniform strain" where uniform strain is defined as the unit strain before neck down. However, it can be shown that significant differences in tensile properties of some materials occur in specimens taken side by side. In the case of carbon steels, the tensile results are within the expected range of repeatability for uniform material and the calculated result for elongation in 5D agrees very well with the measured result.

For low alloy steels, the agreement is not good when the 4D properties are used directly. The calculated value for 5D is 13.8 while the measured is 14.5. However, the yield strength is lower and the reduction in area is higher for the 5D specimen than for the 4D specimen indicating that the material responds differently. A higher elongation is to be expected for the 5D material even if the same gage length is used for both specimens. Therefore, the difference between the calculated and measured 5D elongation is qualitatively consistent with the difference in the strain of the two specimens as shown by the other tensile properties.

Material	Properties	4D gage length	5D gage length
Low Alloy Steel	Tensile Strength (T) ksi	154.0	156.0
	Yield Strength (Y) ksi	139.0	135.0
	Elongation (E) percent	16.0	14.5
	Red. of Area (R) percent	48.6	50.1

To quantitatively estimate this difference, the uniform strain is calculated from the yield strength, tensile strength and the reduction of area of each material separately using an empirical formula (1) below. Then the elongation for each material is calculated at 4D and the measured elongation at 4D multiplied by the ratio of

these calculated values to adjust for material differences [formula (2)]. Then this adjusted elongation is used to calculate the elongation at 5D using the other tensile properties measured on the material tested at 5D [formula (3)].

It is possible to estimate the elongation at 5D from that measured at 4D with useful accuracy for normal structural steels using the following scheme (only for structural steels):

$$\frac{Y}{T}^{0.84} = \frac{4.33(1+0.01U)^{0.84}}{U^{0.51}} \quad (1)$$

Solve for U

For 4D: U' = 4.816%

For 5D: U'' = 5.242%

$$U = \frac{E^2}{\sqrt{E^2 + R^2}} + 0.001 E^2 \quad (2)$$

Solve for E

For 4D: E' = 15.32% in 4D

For 5D: E'' = 16.21% in 4D

Measured elongation in 4D corrected for material difference is:

$$(16.0) \left( \frac{16.21}{15.32} \right) = 16.93\%$$

$$E_{5D} = 0.8 E_{4D} + 0.2U \quad (3)$$

Sample Calculation:

Using (2)

$$U = \frac{(16.93)^2}{\sqrt{(16.93)^2 + (50.1)^2}} + (0.001)(16.93)^2 = 5.706\%$$

From (3)

$$E_{5D} = (0.8)(16.93) + (0.2)(5.706) = 14.7\%$$

As is shown, the calculated value of 14.7 now agrees well with the value of 14.5 obtained from actual testing using a 5D gage length.

*Modulus of Elasticity.* The value derived from the tensile test itself is sometimes referred to as the *static modulus*. Alternatively a *dynamic modulus* may be determined in one or the other of two different types of experiment. In the first a specimen is put in resonance (Kilocycle frequencies and about 0.01 kg/mm<sup>2</sup> peak stress) and the modulus calculated from the theory of resonance. In the second, wave pulses, whose wavelength is small compared to specimen dimensions, are propagated through a specimen and their transit time measured. Frequencies are in megacycles and peak stresses are about 0.001 kg/mm<sup>2</sup> or less. Dynamic values do not always agree closely with static values of the modulus. Attenuation due to grain size effects is one complication. A definitive comparison of modulus data obtained by tests over a wide variety of materials with these techniques has not yet been attempted. It must also be remarked that elastic modulus may also be obtained by x-ray diffraction techniques even with very small samples. In general, however, these results are less precise and may not conform to the more direct, mechanically derived values because they sample only an arbitrary fraction of randomly (?) oriented grains whose orientations happen to be favored for diffraction of the x-rays.

## References

- [1] ASTM E6-81 "Standard Definitions of Terms Relating to Methods of Mechanical Testing".
- [2] ASTM E646-78 "Tensile Strain-Hardening Exponents (n-values) of Metallic Sheet Materials".
- [3] Ramberg, W. and Osgood, W. R., "Description of Stress-Strain Curves by Three Parameters" NACA TN 902, July 1943.



- [4] ———, Military Standardization Handbook, Mil Handbook 5C, "Metallic Materials and Elements for Aerospace Vehicle Structures" (1976) with supplements.
- [5] Sang, H. and Nishikawa, Y., "A Plane Strain Tensile Apparatus" *J. Metals* (1983) 30.
- [6] ASTM E8-82 "Tension Testing of Metallic Materials".
- [7] ASTM A370-77 "Mechanical Testing of Steel Products".
- [8] ASTM B598-74 "Offset Yield Strength for Copper Alloys".
- [9] ASTM B557-81 "Tension Testing of Wrought and Cast Aluminum and Magnesium Alloy Products".
- [10] ASTM B557M-81 "Tension Testing Wrought and Cast Aluminum and Magnesium Alloy Products (Metric)".
- [11] ASTM E345-81 "Tension Testing of Metallic Foil".
- [12] ASTM F606-79A "Conducting Tests to Determine the Mechanical Properties of . . . .Fasteners. . . ."
- [13] ASTM F113-65 "Stiffness Testing of Wire for Electron Devices and Lamps".
- [14] ASTM F219-79 "Testing Fine Round and Flat Wire for Electron Devices and Lamps".
- [15] ASTM E338-81 "Sharp Notch Testing of High-Strength Sheet Materials".
- [16] ASTM E602-81 "Sharp Notch Testing with Cylindrical Specimens".
- [17] ASTM E21-79 "Elevated Temperature Tension Test of Metallic Materials".
- [18] ASTM E517-81 "Plastic Strain Ratio  $r$  for Sheet Metal".
- [19] ASTM E132-61 "Poisson's Ratio at Room Temperature".
- [20] ASTM E231-69 "Static Determination of Young's Modulus at Low and Elevated Temperatures".
- [21] ASTM E111-82 "Young's Modulus, Tangent Modulus and Chord Modulus".
- [22] AK Schmieder (private communications).
- [23] Rudolf, W., "Comparison of Mechanical Properties Determined According to DIN Norms and to ASTM Specifications" *Praktiker* (4), (1981) 80.

## Chapter 2

# HARDNESS NUMBERS

### Introduction

Hardness differs from most other mechanical properties of metals in that it is never used directly in a design calculation and only seldom is a parameter involved in final materials selection. Nonetheless it is one of the most frequently used (an estimated 50 million tests performed each *day* in the United States [1]) and most frequently recorded mechanical characteristics and hence cannot be ignored. Yet it is scoffed at by many scientists as being an unanalyzable complex of many mechanical properties and not susceptible to fundamental interpretation. The explanation for this apparent contradiction may be found in the many practical advantages attendant to the hardness test:

- simplicity of application with saving of labor, time and expense
- convenience—simple, often portable, equipment sometimes permitting testing in situ
- non-destructiveness
- small effective sample size
- direct correlation with service performance

These attractive features make it preeminent for two broad classes of application: initial screening for determination of suitability of a material for a given purpose and maintenance of product uniformity (i.e. processing and compositional controls).

Systematic tests for measurement of hardness date back at least to Reaumur (1722). The methods that have been devised over the years include a) abrasion, b) penetration, c) elastic, d) magnetic, and e) electrical types. Of these, the penetration or indentation type is far and away the most widely used; the remainder of the discussion will be confined to this type.

Common to all the indentation tests is the concept that an indenter of known geometry is impressed upon a flat, smooth surface of the specimen and subjected to a known load, applied perpendicular to the specimen surface. The extent of penetration is determined either concurrently or subsequently by measurement of the depth or diametral extent of the indentation produced. The various standard tests which have been developed over the years differ primarily in indenter material and geometry, load and method of loading, and means of characterizing the resultant indentation. For these reasons, as well as the fact that any hardness test is measuring a combination of mechanical properties, the interconvertibility of the different hardness scales is usually poor and always questionable.

So-called micro-indentation hardness testing, using loads less than 1 kg, is more often applied in scientific studies than engineering work (except for coatings) and therefore will not be discussed here.

### Definitions

*Indentation Hardness*<sup>1</sup>—the hardness as evaluated from measurements of area or depth of the indentation made by pressing a specified indenter into the surface of a material under specified static loading conditions.

*Brinell Hardness Test*<sup>2</sup>—an indentation hardness test using calibrated machines to force a hard ball, under specified conditions, into the surface of a material under test and to measure the diameter of the resulting impression after removal of the load.

*Brinell Hardness Number, HB*<sup>2</sup>—a number related to the applied load and to the surface area of the permanent impression made by a ball indenter computed from the equation:

$$HB = 2P / \pi D (D - \sqrt{D^2 - d^2})$$

where:

P=applied load, kgf,	Ball diameter	10 mm
D=diameter of the ball, mm, and	Load	3000 kgf
d=mean diameter of the impression, mm.	Duration of loading	10 to 15 s

<sup>1</sup>See ASTM E6-81

<sup>2</sup>See ASTM E10-78

For other conditions, the hardness numbers and symbol HB are supplemented by numbers indicating the test conditions in the following order: diameter of ball, load, and duration of loading.

*Rockwell Hardness Test*<sup>3</sup>—an indentation hardness test using a calibrated machine to force a diamond spheroconical penetrator (diamond penetrator), or hard steel ball under specified conditions, into the surface of the material under test in two operations, and to measure the permanent depth of the impression under the specified conditions of minor and major loads.

*Rockwell Hardness Number, HR*<sup>3</sup>—a number derived from the net increase in the depth of impression as the load on a penetrator is increased from a fixed minor load to a major load and then returned to the minor load. This number must always be associated with a particular scale symbol which implies the penetrator, load, and dial used in the test.

Note 1—Penetrators for the Rockwell hardness test include a diamond spheroconical penetrator having an included angle of 120° with a spherical tip having a radius of 0.20 mm and steel balls of several specified diameters.

Note 2—Rockwell hardness numbers are always quoted with a scale symbol representing the penetrator, load, and dial used.

*Vickers Hardness Test*<sup>4</sup>—an indentation hardness test using calibrated machines to force a square-based pyramidal diamond indenter having specified face angles, under a predetermined load, into the surface of the material under test and to measure the diagonals of the resulting impression after removal of the load.

*Vickers Hardness Number, HV*<sup>4</sup>—a number related to the applied load and the surface area of the permanent impression made by a square based pyramidal diamond indenter having included face angles of 136° computed from the equation:

$$HV = 2P \sin(\alpha/2)/d^2 = 1.8544P/d^2$$

where:

P=load, kgf,

d=mean diagonal of impression, mm, and

$\alpha$ =face angle of diamond=136°

NOTE—The Vickers pyramid hardness number is followed by the symbol HV with a suffix number denoting the load and a second suffix number indicating the duration of loading when the latter differs from the normal loading time, which is 10 to 15 s.

## Synonyms

*Vickers hardness number*

VHN

HV

Diamond Pyramid Hardness (DPH)<sup>5</sup>

DHN

DPN<sup>5</sup>

*Brinell hardness number*

Brinell

BHN

HB

R<sub>C</sub>

*Rockwell hardness number*

HRC, HRB, etc.

<sup>3</sup>See ASTM E18-79

<sup>4</sup>See ASTM E92-82

<sup>5</sup>Some writers distinguish DPH and DPN from HV or VHN in that projected rather than pyramidal area is used in calculating the hardness number. This is by no means the general practice.

## Standard Test Methods

The three principal indentation hardness techniques have been thoroughly defined by the standards setting bodies as follows:

	ASTM	B.S.	ISO
Brinell	E10-78	240-1962	R6505-1981
Rockwell	E18-79	891-1962	R80-1968, 2713-1973
Vickers	E92-82	427-1961	R81-1967 R192-1971 R399-1964

In addition to specifying indenter geometry tolerances, loading, calibration and readout procedures, the other important factors covered by the standard test methods are the preparation of the specimen surface and the requisite size of the effective sample relative to the size of the indentation. The latter requirement implies a minimum thickness of the specimen, a minimum separation of indentations and a minimum spacing of any indentation from the edge of the specimen. Factors that may not be adequately controlled, despite conformance otherwise with the testing specification, include vibration, rate of loading or time of indentation. Choice of a load/ball combination inappropriate to the hardness level of the specimen may also be a factor in ball indentation. For the Rockwell test, the combinations of table 1 are specified.

Table 1. Rockwell test scales, indenting conditions, and typical applications

Scale Symbol	Penetrator	Major Load, kgf	Dial Figures	Typical Applications of Scales
B	1/16-in. (1.588-mm) ball	100	red	Copper alloys, soft steels, aluminum alloys, malleable iron, etc.
C	diamond	150	black	Steel, hard cast irons, pearlitic malleable iron, titanium, deep case hardened steel, and other materials harder than B 100.
A	diamond	60	black	Cemented carbides, thin steel, and shallow case-hardened steel.
D	diamond	100	black	Thin steel and medium case hardened steel, and pearlitic malleable iron.
E	1/8-in. (3.175-mm) ball	100	red	Cast iron, aluminum and magnesium alloys, bearing metals.
F	1/16-in. (1.588-mm) ball	60	red	Annealed copper alloys, thin soft sheet metals.
G	1/16-in. (1.588-mm) ball	150	red	Malleable irons, copper-nickel-zinc and cupro-nickel alloys. Upper limit G 92 to avoid possible flattening of ball.
H	1/8-in. (3.175-mm) ball	60	red	Aluminum, zinc, lead.
K	1/8-in. (3.175-mm) ball	150	red	
L	1/4-in. (6.350-mm) ball	60	red	
M	1/4-in. (6.350-mm) ball	100	red	Bearing metals and other very soft or thin materials. Use smallest ball and heaviest load that does not give anvil effect.
P	1/4-in. (6.350-mm) ball	150	red	
R	1/2-in. (12.70-mm) ball	60	red	
S	1/2-in. (12.70-mm) ball	100	red	
V	1/2-in. (12.70-mm) ball	150	red	

For the Brinell test, the load is selected for a particular ball diameter to give the ratio of indentation diameter to ball diameter approximating the ideal of .375.

Table 2. Standard Brinell Test Loads (ASTM E10-78)

Ball Diameter, mm	Load, kgf	Recommended Range, HB
10	3000	96 to 600
10	1500	48 to 300
10	500	16 to 100

## Standards for Reporting Data

The data report should include beside the hardness number, the test conditions regarding load, indenter and time of loading whenever these differ from conditions required by the testing specifications. In addition, although not called out in these documents, assurance should be given that processing conditions were such as to yield a homogeneous specimen, both laterally in the test surface and in depth (at least to distances sensed by the penetrating indenter).

## Precision and Accuracy

Examples of the repeatability which should be achievable under the Rockwell and Vickers tests are shown in tables 3 and 4. Standard reference blocks, referred to in the tables, having certified hardness values and exceptional uniformity, are available from many hardness tester manufacturers.

**Table 3.** Repeatability of the Rockwell hardness test

Range of Standardized Hardness Test Blocks	The Repeatability <sup>A</sup> of the Machine Shall Be Not Greater Than:
<i>Rockwell C Scale:</i>	
20 to 30	2.0
35 to 55	1.5
59 to 65	1.0
<i>Rockwell B Scale:</i>	
40 to 59	2.5
60 to 79	2.0
80 to 100	2.0
<i>Rockwell 30N Scale:</i>	
40 to 50	2.0
55 to 73	1.5
75 to 80	1.0
<i>Rockwell 30T Scale:</i>	
43 to 56	2.5
57 to 70, incl	2.0
Over 70 to 82	2.0

<sup>A</sup> The repeatability of machines on Rockwell or Rockwell superficial hardness scales other than those given in Table 20 shall be the equivalent converted difference in hardness for those scales, except for the 15N and 15T scales. In the case of the 15N and 15T scales, the repeatability shall be no greater than 1.0 for all ranges.

*Example*—At C 60, typical readings of a series of impressions might range from 59 to 60, 59.5 to 60.5, 60 to 61, etc. Thus, converted A-scale values corresponding to C 59 to 60 (see Table II of Standard Tables E 140) would be A 80.7 to 81.2 and the repeatability for the A-scale would be 0.5.

**Table 4.** Repeatability of the Vickers hardness test

Range of Standardized Hardness of Test Blocks	The Repeatability of the Machine Should be Less Than:	Examples of Equivalents in Hardness Units
100 to 240, incl	4 % of $d^{A,B}$	8 at 100 HV; 16 at 200 HV
Over 240 to 600, incl	3 % of $d^{A,B}$	18 at 300 HV; 36 at 600 HV
Over 600	2 % of $d^{A,B}$	28 at 700 HV

<sup>A</sup>  $d = (d_1 + d_2 + \dots + d_n)/5$ .

<sup>B</sup> In all cases the repeatability is the percentage given or 1  $\mu\text{m}$  (0.001 mm), whichever is the greater.

## Correlations

Because of the great variety of hardness tests in use and the existence of different scales for the same basic test, there is naturally a great desire for interconversion. Yet recognition of the fact that hardness is not a fundamental property but a combination of several properties whose mix changes from test to test foredooms any exact conversion to failure. For example, differences in elastic modulus or in strain hardening capacity of different metals will inevitably cause differences in the hardness conversion relationships. Even differences in the state of cold work of a single material will affect the conversion. Despite these difficulties, hardness conversion tables for various families of materials have been published by the standardizing bodies (ASTM E140-79 and BS860). All such tables, charts or graphs should be employed with great caution and viewed *as estimates only*, in the absence of a direct, ad hoc calibration for the particular material and pair of tests at hand.

Correlations of hardness with other properties of a material are also inexact for the same reason but are nonetheless useful. For example, the fact that electrical and magnetic properties are sensitive to composition, mechanical and thermal treatment as is hardness opens the way to non-contact measurement of relative hardness. Such comparative techniques are generally satisfactory for inspection control of a given material or for scrap sorting.

Correlations of hardness with other mechanical properties are more direct and in that sense more useful even though inexact and perhaps confined to a narrow family of materials. Examples are shown in figures 1 to 3.

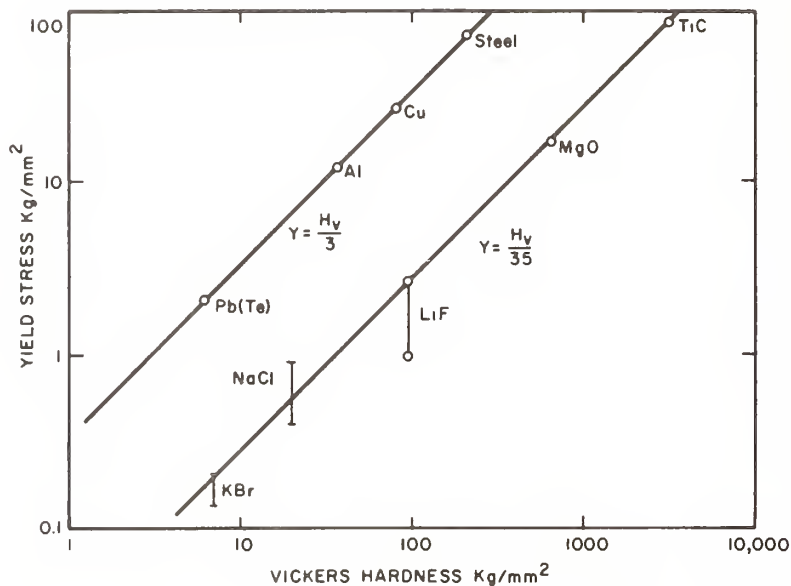

Figure 1. Correlation lines for metals and ionic crystals relating hardness numbers and yield stresses (after J. H. Westbrook [2]).

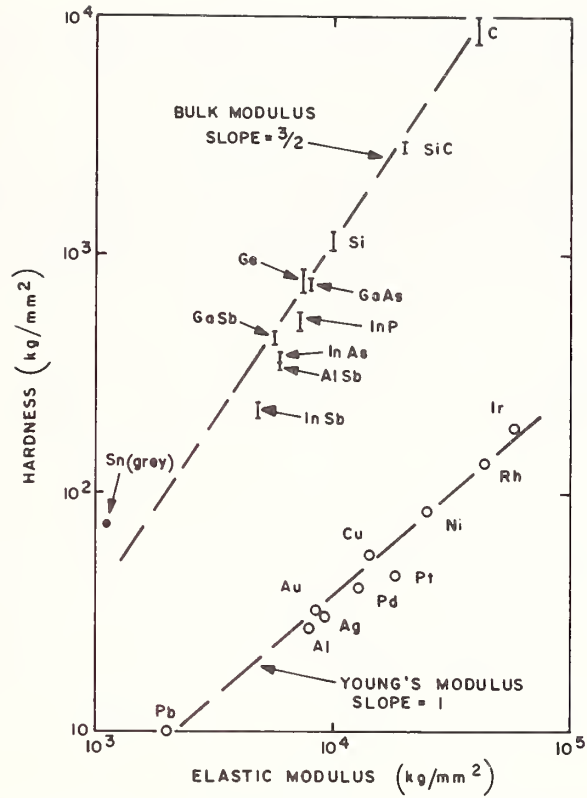

Figure 2. Correlation of hardnesses and elastic moduli for pure fcc metals and covalent crystals (after J. J. Gilman [2]).

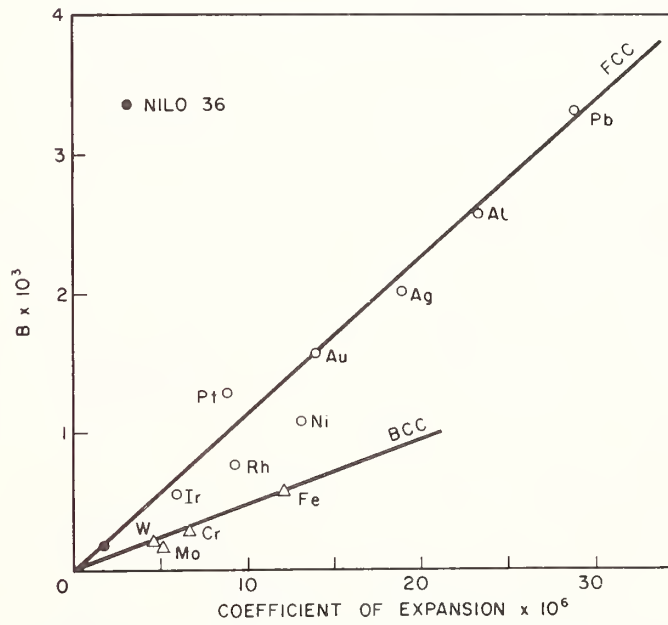

Figure 3. Vickers hardness softening coefficient ( $B$ ) for metals (including low-expansion alloy, Nilo 36) and thermal coefficient of expansion (Petty and O'Neill, *Metallurgia*, Jan. 1961 [3]).

## References

- [1] Petty, E. R., "Hardness Testing" in *Techniques of Metals Research* v, part 2, R. F. Bunshah, ed., Interscience, NY (1971) 157.
- [2] Westbrook, J. H., and Conrad, H., eds., "The Science of Hardness Testing and Its Research Applications," ASM, Metals Park, OH (1973).
- [3] O'Neill, H., "Hardness Measurement of Metals and Alloys," Chapman and Hall, London (1967).
- [4] Williams, S. R., "Hardness and Hardness Measurements," ASM, Cleveland, OH (1942).



# Chapter 3

## NOTCH BAR IMPACT TEST PARAMETERS

### Introduction

It was discovered quite early that catastrophic failures sometimes occurred in structural members where the mean stress was clearly well below the yield stress as measured in a conventional tensile test. In practice such failures were alarming, not just because they were not predictable from prior testing, but also because little warning by way of deformation preceded failure and the failure itself was a low energy process. Further experience indicated that failures of this type, particularly in ferrous materials, were associated with the presence of notches, with high rates of loading and with low temperatures. Such observations were not always correctly interpreted: notches introduce extra rigidity, not simply stress concentration; high strain rates are not intrinsically embrittling but they do raise the temperature at which brittle failure occurs. In any event both materials engineers and designers finally recognized that a new type of test was needed to characterize this behavior [1].

The beam loaded impact test, as a measure of toughness or energy absorption capacity, was introduced by Tetmajer in 1883 and brought to its current form by Izod in 1903 and Charpy in 1904. The latter tests differ both in mode of loading (cantilever beam vs simple beam) and in notch geometry (V-notch vs U-notch vs keyhole notch) as shown in figure 1. Although the original hope that parameters from such tests might be used directly in design calculations has now been vitiated, the value of the Charpy V-notch (CVN) test as a reliable comparative measure of the impact behavior of materials has never been greater. It is only this form of impact test that will be addressed here.

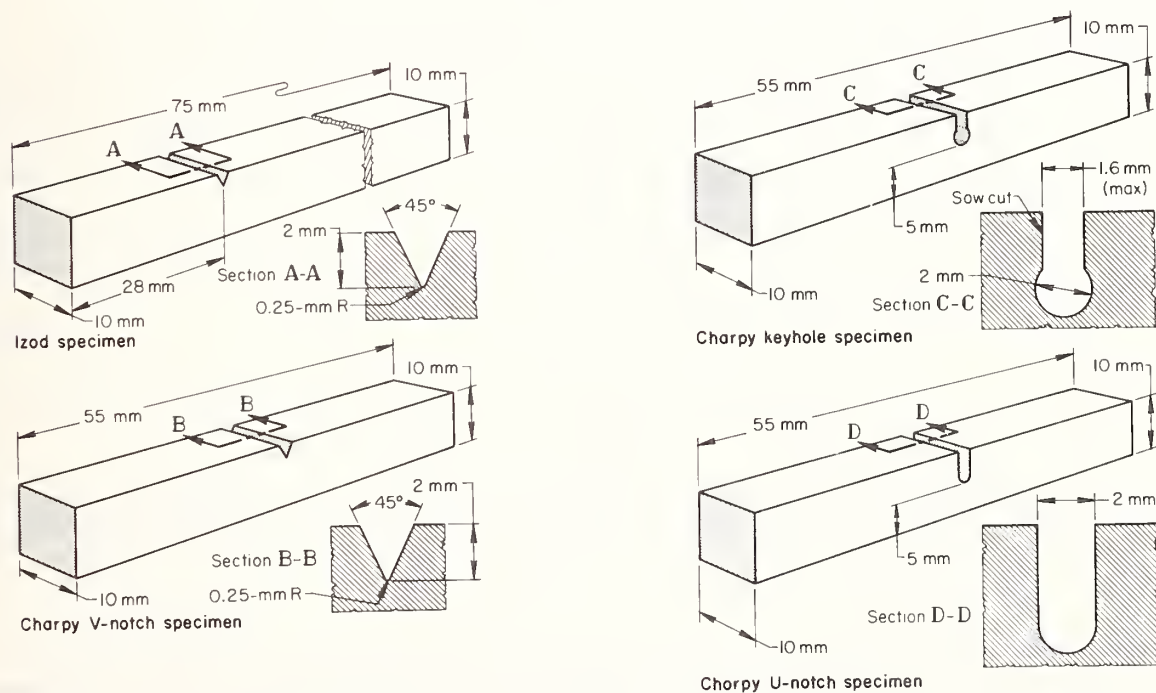

Figure 1. Dimensional details of Izod and Charpy test specimens as called for in ASTM E23-82 (from ASM Handbook, 8th ed.).

An important aspect of this test is that steels and other strong materials frequently exhibit a suddenly reduced capacity for energy absorption as the temperature is lowered in the vicinity of room temperature. This characteristic behavior has led to some debate as to which parameters of the impact strength-temperature curve are most useful in characterizing material behavior or should the entire curve be somehow represented analytically. Oldfield [2] has proposed representing the Charpy-temperature characteristic by the function

$$Y = A + B \tanh\left(\frac{T - T_0}{C}\right)$$

where  $Y$  is the fracture property (CVN energy, % shear, or lateral expansion),  $A$ ,  $B$ ,  $C$  and  $T_0$  are constants and  $T$  is the test temperature. From the representation shown in figure 2, it may be seen that  $A + B$  and  $A - B$  may be taken as the upper and lower shelf energies respectively and that  $T_0$  is the transition temperature corresponding to an energy median definition (see below). Not only was this function found to give a fair representation of a wide variety of impact data but the fitting parameters can be transformed by a specified procedure [2] to produce an analogous function predicting the fracture toughness relationship, both mean values and tolerance bounds.

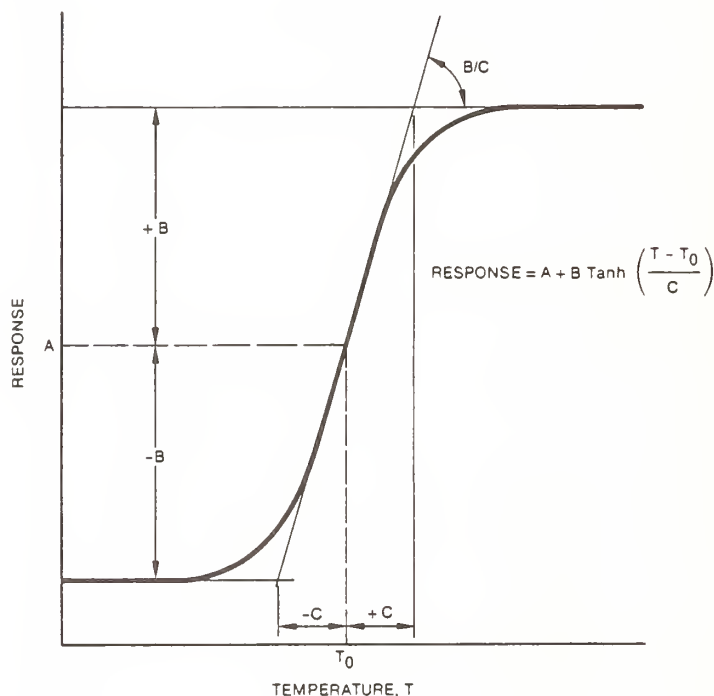

Figure 2. Schematic of the hyperbolic tangent function representing the temperature dependence of impact toughness (after Oldfield [3]).

Mention must also be made of the so-called “instrumented Charpy impact test” which can provide load-time information as well as energy absorption [4]. This additional information is derived from strain gages applied to the Charpy striker and read out through an oscilloscope. By analysis of the load-time trace, the total energy absorbed can be divided into the energy required to initiate fracture, the energy to propagate brittle fracture and the energy associated with the shear-lip formation.

### Definitions<sup>1</sup>

*Impact Value*—The energy absorbed in breaking the specimen, equal to the difference between the energy in the striking member of the impact apparatus at the instant of impact with the specimen and the energy remaining after breaking.

<sup>1</sup>Neither ASTM E6-81 (Standard Definitions of Terms Relating to Methods of Mechanical Testing) nor ASTM E23-82 (Notched Bar Impact Testing) contains these definitions in explicit form. These definitions have been composed by the author.

*Transition Temperature*—That temperature at which a material exhibits a transition from ductile to brittle behavior as variously defined:

*Average Energy Transition Temperature*—The temperature corresponding to the median between the maximum energy (high temperature region) and the minimum energy (low temperature region).

*Temperature for Stated Energy Absorption*—The temperature at which an arbitrary level of energy is absorbed, typically 15 or 30 ft. lbs. Gross [5] has suggested that this level should be increased with increasing tensile strength so as to ensure a constant notch ductility (lateral expansion).

*Average Temperature Transition Temperature*—The median temperature of the transition temperature range.

*Fracture Appearance Transition Temperature (FATT)*—The temperature at which the ratio of the area of fibrous (shear) to crystalline (cleavage) fracture is at a specified level, e.g. equal parts—50% FATT; or 100% shear—100% FATT.

*Lateral Expansion Transition Temperature*—The temperature at which the lateral expansion in the fractured specimen (increase in specimen width on the compression side, opposite the notch) is some specified amount.

*Brittle Fracture Transition Temperature*—Temperature at which maximum load first equals load to brittle fracture (determinable from the instrumented Charpy test).

*Nil Ductility Transition Temperature (NDTT)*—A transition temperature, derived from a drop weight test, defined as the maximum temperature where a standard drop weight specimen fractures when tested as specified in ASTM E208. This parameter does *not* relate to the Charpy notch bar impact test.

*Upper Shelf Energy*—The level of the energy plateau above the transition temperature.

*Lower Shelf Energy*—The level of the energy plateau below the transition temperature.

*Per Cent Shear Fracture*—A subjective determination of the relative cross-sectional area of the impact specimen exhibiting shear (ductile or fibrous) fracture.

## Synonyms

### *Charpy V-Notch Impact Strength*

	Synonymous Terms	Not Synonymous
notch toughness	Charpy V-notch impact	fracture toughness
impact strength	Charpy V-notch IE	Izod strength
Charpy V-notch	Charpy V-impact energy	Izod impact strength
CVN	Charpy strength	DT strength
impact toughness	impact energy	
impact value	Cv	

## Standard Test Methods

The basic ASTM method for notched bar impact testing of metallic materials is ASTM E23-82. This is supplemented by the following ASTM methods which also bear on impact testing:

ASTM A370-77	Mechanical Testing of Steel Products
ASTM A673-82	Sampling Procedure for Impact Testing of Structural Steel
ASTM A327-72	Impact Testing of Cast Irons

Numerous factors can affect the results obtained from the Charpy impact test. The most important are:

*Specimen-related*

- notch dimensions<sup>2</sup>
- tool marks left in notch
- specimen size

*Machine-related*

- rigidity
- linear velocity of pendulum (16 to 19 ft/sec)
- anti-jamming provisions<sup>3</sup>
- energy range<sup>4</sup>
- relative mass of tup and anvil
- geometry of tup and hammer ("C"-type vs "U"-type)

The ISO standard corresponding to ASTM E23 is R442-1965. In general R442's allowable variations in geometric tolerances and its failure to specify rigid mounting of the machine to an adequate foundation are such as to yield impact values different by as much as 20% from those obtained under the ASTM specification.

## Standards for Reporting Data

ASTM E23-82 calls for reporting of various factors in addition to energy values themselves. Among these are:

- type of specimen
- size of specimen
- temperature
- presence of anti-jamming features

Particular specifications may also call for recording

- orientation of specimen relative to processing direction
- nature of sampling
- fracture appearance
- lateral expansion
- average energy value
- minimum energy value

The writer also recommends that the yield strength or hardness be recorded as a crude measure of the result of heat treatment and other processing in establishing equivalent structures.

## Precision and Accuracy

Tests run by the Army Materials and Mechanics Research Center (AMMRC) under carefully controlled conditions show that the Charpy V-notch impact test is both reliable and highly reproducible. The results on 1200 specimens of a single heat of steel, heat-treated to three different hardness levels and tested in two different machines, are shown in figure 3. The spreads in impact energy observed were essentially independent of the test machine and were typically within  $\pm 10\%$  at the highest impact strength level and  $\pm 15\%$  at the lowest impact strength level tested. Still, heat-to-heat variations, differences in processing history and sampling location can add considerably to the spread in test results even when the testing is most rigorously controlled. The AMMRC laboratory has continued to be active in establishing the reliability of this test and calibration of test machines. Calibration specimens of AISI 4340 are available at the 15, 30 (formerly), and 70 ft-lb levels, and current work with ASTM Committee 28.07 is being conducted for the 150 ft-lb level. No determination of precision or accuracy in impact testing yet bears ASTM imprimatur.

---

<sup>2</sup>Modest variation in notch dimensions from those of standard specimens have been shown by Fahey [6] to lead to  $\pm 5\%$  changes in impact energy in high energy specimens ( $\sim 76$  ft lbs) and  $+27\%$ ,  $-14\%$  in low energy specimens ( $\sim 12.5$  ft lbs).

<sup>3</sup>The broken pieces of the test specimen must be free to leave the machine with a minimum of interference and not rebound into the pendulum before the pendulum completes its swing.

<sup>4</sup>The energy values from the test should be within 80% of the machine capacity, typically 220 ft lbs.

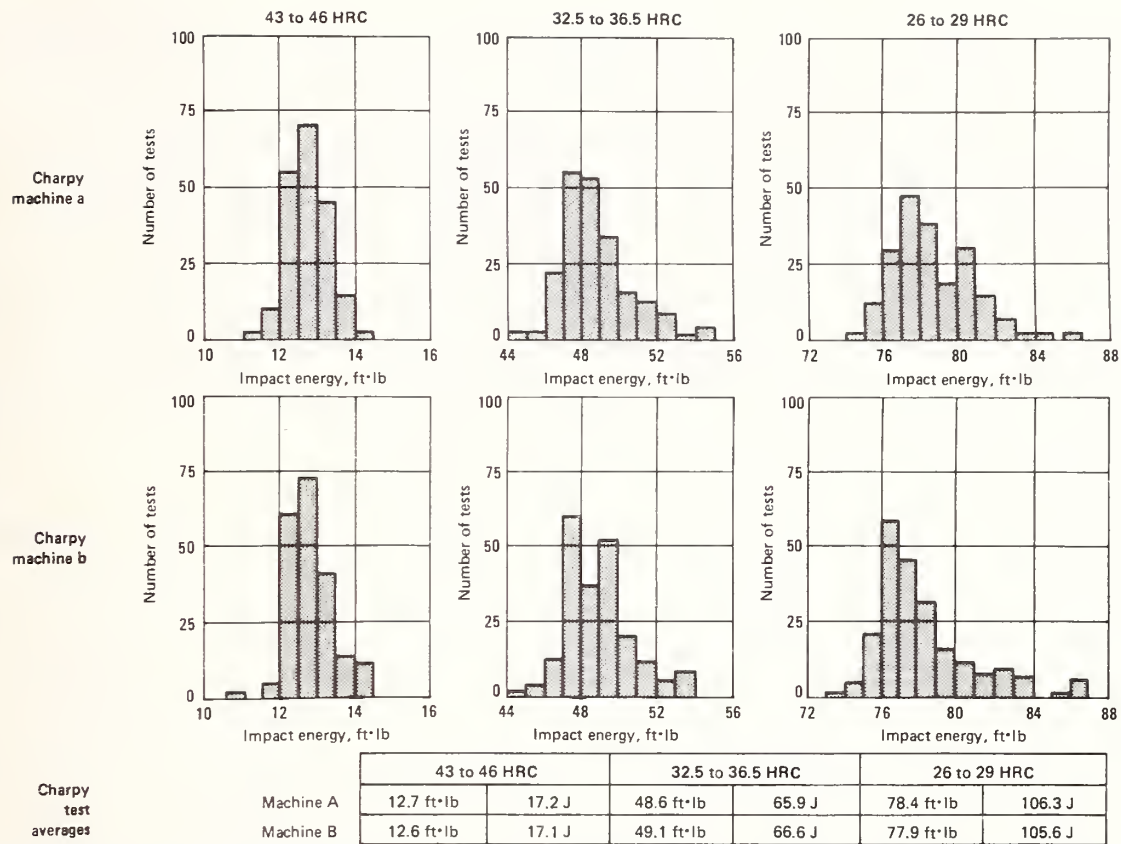

Comparison of test results from two Charpy impact machines manufactured by two companies. 1200 specimens were made from a single heat of aircraft-quality 4340 steel. Specimens were hardened and tempered to three hardness levels: 43 to 46 HRC, 32.5 to 36.5 HRC and 26 to 29 HRC. 200 specimens at each of the three hardness levels were tested at 21 °C (70 °F) on each of the impact machines. (Ref 1)

Figure 3. Reproducibility of impact test results derived from extensive testing of AMMRC (from ASM Handbook, 9th ed.).

The Community Bureau of Reference (BCR) of the European Economic Community (EEC) has also been working to establish reliable reference materials for the notch-bar impact test. Working with four different laboratories in the EEC, the BCR had round robin tests on AISI 4340 steel conducted to ascertain the contribution to scatter of heat treatment, testing laboratory, sample direction, and steel making and refining practices [7]. The major finding of this study is that increased purity and homogeneity of the steel afforded by electroslag remelting as compared to vacuum arc remelting or normal air melting increased the mean impact energy (at the 100 J, 74 ft·lb level), reduced the difference between the longitudinal and transverse directions, and narrowed the dispersion of the results.

## Correlations

Notch bar impact behavior is not predictable from parameters from simpler tests such as tensile ductility. Specimens exhibiting equal ductility will frequently be found to have radically different notch impact strengths. Another illustration of the unique character of the notch toughness parameter is found in figure 4 which shows the variation in impact behavior of a medium carbon steel tempered to various strength levels. Significant variations are seen in the upper shelf energy, much lesser changes in transition temperature, and almost no change in the lower shelf energy. Of much greater importance is the use of impact energy measurements to predict plane strain fracture toughness,  $K_{IC}$ , because of the greater complexity and expense of the latter test. Such correlations have been reported by Barsom and Rolfe [8], Groves and Wallace [9], Goode et al. [10], and Wullaert [11]. An example is shown in figure 5. Much further work needs to be done to establish fully the conditions under which reliable correlations may be expected.

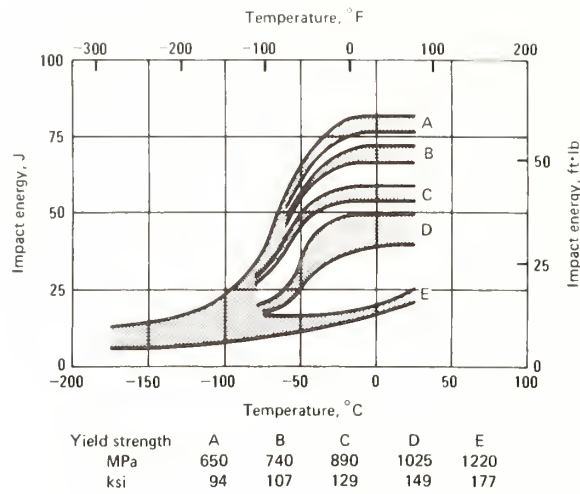

Figure 4. Variation in impact behavior of a steel tempered to various strength levels (from ASM Handbook, 9th ed.).

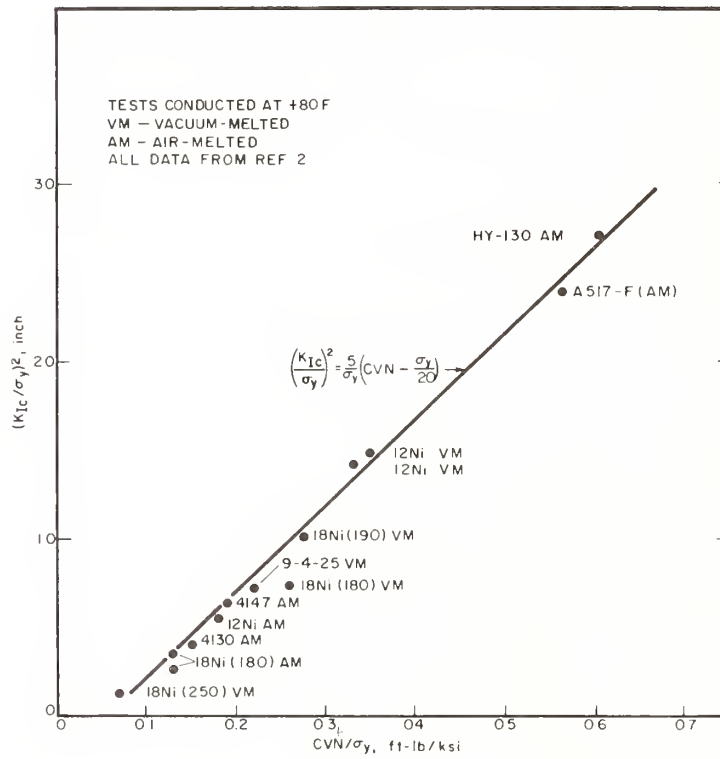

Figure 5. Correlation between fracture toughness  $K_{Ic}$  and Charpy V-notch-impact strength in the upper shelf region (after Barsom and Rolfe [8]).

## Concluding Remarks

In considering what numbers should be stored in a computer file to describe some property, compromise must always be effected between those fundamental parameters that are most meaningful and the values one is likely to find available for a broad range of materials. This is certainly true of the notch impact situation. While one might desire the full characterization of the impact-temperature curve or the additional information afforded by the instrumented Charpy test, what one is most likely to find tabulated is a simple impact energy value, usually at room temperature, or a transition temperature. In any event, it is most important, however skimpy the impact data themselves may be, that the other descriptive parameters relative to the test or the specimen be included in the computer file as well.

It is recommended that standard test procedures for notched bar impact behavior include explicit definitions of critical terms and the reporting requirement of some parameter characterizing the strength level of the specimen.

## References

- [1] Hoyt, S. L., "Notch Bar Testing—Theory and Practice," ASTM Symp. on Impact Testing, STP 176, (1955) 3.
- [2] Oldfield, W., "Development of Fracture Toughness Reference Curves," *J. Eng. and Materials Technology* **102** (1980) 107.
- [3] Oldfield, W. and Marston, T. U., "Fracture Toughness Prediction Method for Ferritic Steels," SMIRT-7, Post Conference Seminar (1983).
- [4] Turner, C. E., "Measurement of Fracture Toughness by Instrumented Impact Test," fm. *Impact Testing*, ASTM STP 466 (1970) 93.
- [5] Gross, J. H., "Effect of Strength and Thickness on Notch Ductility," *ibid.* p. 21.
- [6] Fahey, N. H., "Effects of Variables in Charpy Impact Testing," *Materials Research and Standards* **1**, No. 11 (1961) 872.
- [7] Helms, R. and Ledworuski, S., "Reference Material for Proof Tests of Method and Apparatus for Notched-Bar Impact Tests," fm. *Production and Use of Reference Materials*, B. F. Schmitt, ed., Bundesanstalt fur Materialprufung, Berlin (1980).
- [8] Barsom, J. M., and Rolfe, S. T., "Correlations Between  $K_{Ic}$  and Charpy V-Notch Test Results in the Transition Temperature Range," fm. *Impact Testing*, ASTM STP 466 (1970) 281.
- [9] Groves, M. T., and Wallace, J. F., "Cast Steel Plane Fracture Toughness, Charpy V-Notch and Dynamic Tear Test Correlations," *J. Steel Castings Res.*, No. 70 (1975) 1.
- [10] Goode, R. W. et al., "Metallurgical Characteristics of High Strength Structural Materials," NRL Report 6607 (Sept. 1967).
- [11] Wullaert, R. H., "Fracture Toughness Predictions from Charpy V-Notch Data," AIME Meeting, Denver, CO (Feb. 1978).

## Chapter 4

# FATIGUE PROPERTIES

### Introduction

Fatigue is the progressive damage suffered by a material subjected to repeated application of stress. At some point the loading regime leads to the formation of a crack. This crack grows in extent with each successive application of tensile stress until the remaining, uncracked portion is unable to carry the load, at which time sudden, complete fracture occurs. Systematic testing and analysis of the fatigue phenomenon has been going on since the pioneering work of Wöhler over a century ago.

Much information has been gained, to the point that general precepts can be laid down that will help avoid fatigue failure, and the beginnings of a quantitative approach to engineering design from a fatigue viewpoint have been established. However, fundamental understanding is still somewhat limited as is our ability to deal with complex stress (strain) history and concomitant effects of environment, surface condition, etc. Not only is the process inherently probabilistic, but the many variables may differently affect the initiation and propagation of a crack.

We will consider here only fatigue properties associated with conventional room temperature testing. The important but more complex behaviors associated with high temperature fatigue, stress-corrosion fatigue, fretting fatigue and complex loading will not be treated, because so little consensus has yet been achieved in these areas with respect to definitions and test methods. Existing ASTM standards do not read on these more complex behaviors and loading conditions, excepting appendix X4 to E606-80 which provides "guidance" for elevated temperature, low cycle fatigue testing. The Fatigue Design and Evaluation Steering Committee of the Society of Automotive Engineers (SAE) has also been active in these areas with respect to standardizing test methods, collecting and analyzing data, etc. Thomas [13] and Coffin [14] have provided useful overviews of high temperature fatigue with respect to testing standards and phenomenology, respectively.

### Definitions (From ASTM E206-72 or E513-74 except where noted)

*cycle*—one complete sequence of values of stress or strain that is repeated periodically.

*hysteresis diagram*—the stress-strain path during one cycle.

*fatigue*—the process of progressive localized permanent structural change occurring in a material subjected to conditions which produce fluctuating stresses and strains at some point or points and which may culminate in cracks or complete fracture after a sufficient number of fluctuations.

(ASTM Notes omitted)

*fatigue life, N*—the number of cycles of stress or strain of a specified character that a given specimen sustains before failure of a specified nature occurs.

*S-N diagram*—a plot of stress against the number of cycles to failure. The stress can be  $S_{min}$ ,  $S_{max}$ , or  $S_a = [\text{one half the range of stress, } (S_{max} - S_{min})/2]$ . (See fig. 1 for graphical representation of these definitions.) The diagram indicates the S-N relationship for a specified value of  $S_m = [\text{mean stress, } (S_{min} + S_{max})/2]$ ,  $A = [S_a/S_m]$  or  $R = [S_{min}/S_{max}]$  and a specified probability of survival. For N a log scale is almost always used. For S a linear scale is used most often, but a log scale is sometimes used.

*fatigue strength at N cycles, S* [ $FL^{-2}$ ]—a hypothetical value of stress for failure at exactly N cycles as determined from an S-N diagram. The value of S thus determined is subject to the same conditions as those which apply to the S-N diagram.

(ASTM Note omitted)

*median fatigue life*—the middlemost of the observed fatigue life values, arranged in order of magnitude, of the individual specimens in a group tested under identical conditions.

(ASTM Note omitted)



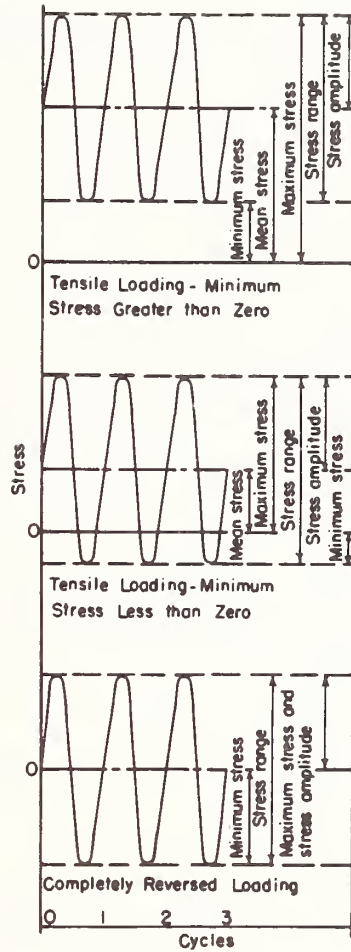

Figure 1. Typical fatigue loadings and definitions of stress terms.

*range of stress,  $S_r$ ,  $[FL^{-2}]$* —the algebraic difference between the maximum and minimum stresses in one cycle, that is  $S_r = S_{\max} - S_{\min}$ .

*stress ratio,  $A$  or  $R$* —the algebraic ratio of two specified stress values in a stress cycle. Two commonly used stress ratios are: The ratio of the alternating stress amplitude to the mean stress, that is,

$$A = S_a / S_m \quad (1)$$

and the ratio of the minimum stress to the maximum stress, that is,

$$R = S_{\min} / S_{\max} \quad (2)$$

*median fatigue strength at  $N$  cycles  $[FL^{-2}]$* —an estimate of the stress level at which 50 percent of the population would survive  $N$  cycles.

Note—The estimate of the median fatigue strength is derived from a particular point of the fatigue life distribution, since there is no test procedure by which a frequency distribution of fatigue strength at  $N$  cycles can be directly observed.

Note—This is a special case of the more general definition (see immediately below).

*fatigue strength for  $p$  percent survival at  $N$  cycles  $[FL^{-2}]$* —an estimate of the stress level at which  $p$  percent of the population would survive  $N$  cycles;  $p$  may be any number, such as 95, 90, etc.

Note—The estimates of the fatigue strengths for p percent survival values are derived from particular points of the fatigue life distribution, since there is no test procedure by which a frequency distribution of fatigue strengths at N cycles can be directly observed.

*fatigue limit,  $S_f[FL^{-2}]$* —the limiting value of the median fatigue strength as N becomes very large.

Note—Certain materials and environments preclude the attainment of a fatigue limit. Values tabulated as “fatigue limits” in the literature are frequently (but not always) values of  $S_n$  for 50 percent survival at N cycles of stress in which  $S_m=0$ .

*cycle ratio, C*—the ratio of the number of stress cycles, n, of a specified character to the hypothetical fatigue life, N, obtained from the S-N diagram, for stress cycles of the same character, that is,  $C=n/N$ .

*fatigue notch factor,  $K_f$* —the ratio of the fatigue strength of a specimen with no stress concentration to the fatigue strength at the same number of cycles with stress concentration for the same conditions.

Note—In specifying  $K_f$  it is necessary to specify the geometry and the values of  $S_{max}$ ,  $S_m$ , and N for which it is computed.

*constant life fatigue diagram*—a plot (usually on rectangular coordinates) of a family of curves, each of which is for a single fatigue life, N, relating  $S_m$ ,  $S_{max}$  and/or  $S_{min}$  to the mean stress  $S_m$ . The constant life fatigue diagram is generally derived from a family of S-N curves, each of which represents a different stress ratio (A or R) for a 50 percent probability of survival. (See fig. 2.) Author’s note: This is also referred to as a modified Goodman diagram.

*cyclic stress-strain curve*<sup>1</sup>—the cyclic stress-strain curve is defined as the locus of tips of stable “true” stress-strain hysteresis loops obtained from companion test specimens tested under axial cyclic strain control. See figure 3.

*cyclic yield strength (0.2%  $\sigma_{ys}$ )*<sup>1</sup>—is the stress to cause 0.2% inelastic strain as measured on a cyclic stress-strain curve. It is usually determined by constructing a line parallel to the slope of the cyclic stress-strain curve at zero stress through 0.2% strain and zero stress. The stress where the constructed line intercepts the cyclic stress-strain curve is taken as the 0.2% cyclic yield strength.

*cyclic strain hardening exponent ( $n'$ )*<sup>1</sup>—is the power to which “true” plastic strain amplitude must be raised to be proportional to “true” stress amplitude. It is taken as the slope of the log  $\Delta\sigma/2$  versus log  $\Delta\epsilon_p/2$  plot, where  $\Delta\epsilon_p/2$  and  $\Delta\sigma/2$  are measured from cyclically stable hysteresis loops.

$$\Delta\sigma/2 = K'(\Delta\epsilon_p/2)^{n'}$$

where  $\Delta\epsilon_p/2$  = “true” plastic strain amplitude. The line defined by this equation is illustrated in figure 4.

*cyclic strength coefficient ( $K'$ )*<sup>1</sup>—is the “true” stress at a “true” plastic strain of unity in eq 11. It may be necessary to extrapolate as indicated in figure 4.

*fatigue ductility exponent ( $c$ )*<sup>1</sup>—is the power to which the life in reversals must be raised to be proportional to the “true” strain amplitude. It is taken as the slope of the log  $(\Delta\epsilon_p/2)$  versus log  $(2N_f)$  plot. (See fig. 5.)

*fatigue ductility coefficient ( $\epsilon'_f$ )*<sup>1</sup>—is the “true” strain required to cause failure in one reversal. It is taken as the intercept of the log  $(\Delta\sigma/2)$  versus log  $(2N_f)$  plot. (See fig. 5.)

*fatigue strength exponent ( $b$ )*<sup>1</sup>—is the power to which life in reversals must be raised to be proportional to “true” stress amplitude. It is taken as the slope of the log  $(\Delta\sigma/2)$  versus log  $(2N_f)$  plot.

*fatigue strength coefficient ( $\sigma'_f$ )*<sup>1</sup>—is the “true” stress required to cause failure in one reversal. It is taken as the intercept of the log  $(\Delta\sigma/2)$  versus log  $(2N_f)$  plot at  $2N_f=1$ .

*transition fatigue life ( $2N_t$ )*<sup>1</sup>—is the life where elastic and plastic components of the total strain are equal. It is the life at which the plastic and elastic strain-life lines cross. (See fig. 5.)

<sup>1</sup>From SAE J1099 [1].

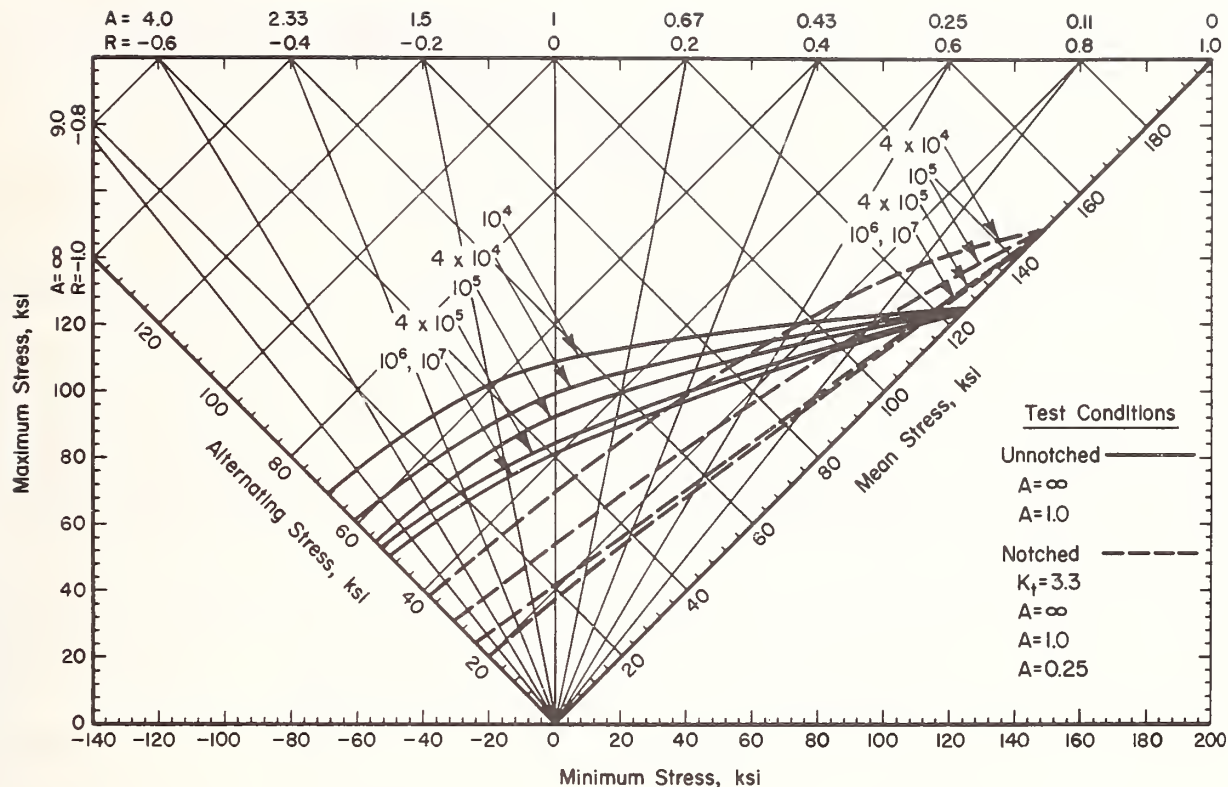

Correlative Information for Figure 2

Product Form: Rolled Bar, 1-1/8 inches diameter

Test Parameters:  
 Loading—Axial  
 Frequency—2000 to 2500 cpm  
 Temperature—RT  
 Atmosphere—Air

Properties:	TUS, ksi	TYS, ksi	Temp. F
	125.0	—	RT (Unnotched)
	150.2	—	RT (Notched)

Specimen Details:	Unnotched:	Notched, V-Groove, $K_t=3.3$
	0.400-inch diameter	0.450-inch gross diameter
		0.400-inch net diameter
		0.010-inch root radius, r
		60° flank angle, $\omega$

$$K_N = 2.34, \rho = 0.0023 \text{ inch, where } K_N = 1 + \frac{K_t - 1}{1 + \frac{\pi}{\pi - \omega} \sqrt{\frac{\rho}{r}}}$$

Surface Condition:	Unnotched:	Hand polished to 10 microinches RMS
	Notched:	Lathe turned to 10 microinches RMS

Figure 2. Typical constant-life fatigue diagram for heat-treated AISI 4340 alloy steel (bar),  $F_w = 125$  ksi. (from Mil Handbook 5).

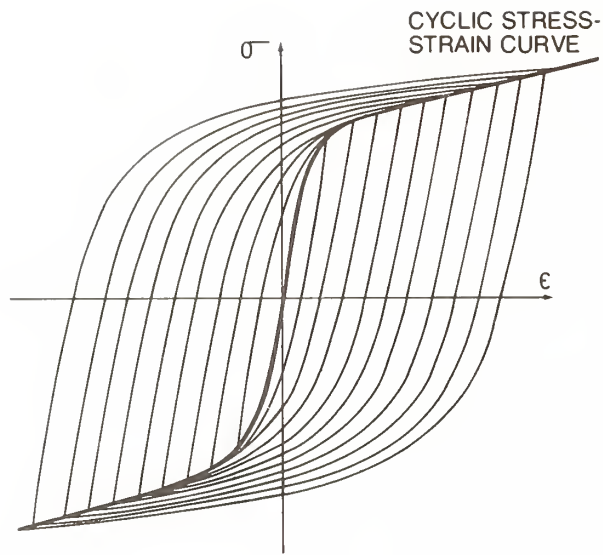

Figure 3. Cyclic stress-strain curve drawn through stable loop tips [1].

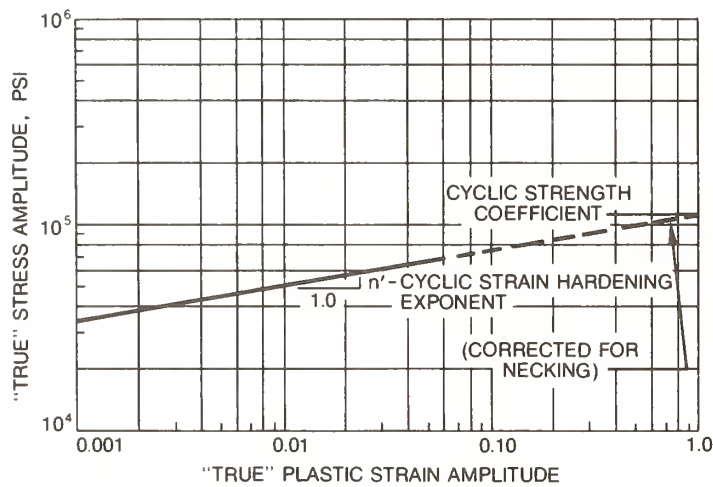

Figure 4. Cyclic stress-plastic strain plot, 1020 H. R. Steel. [1].

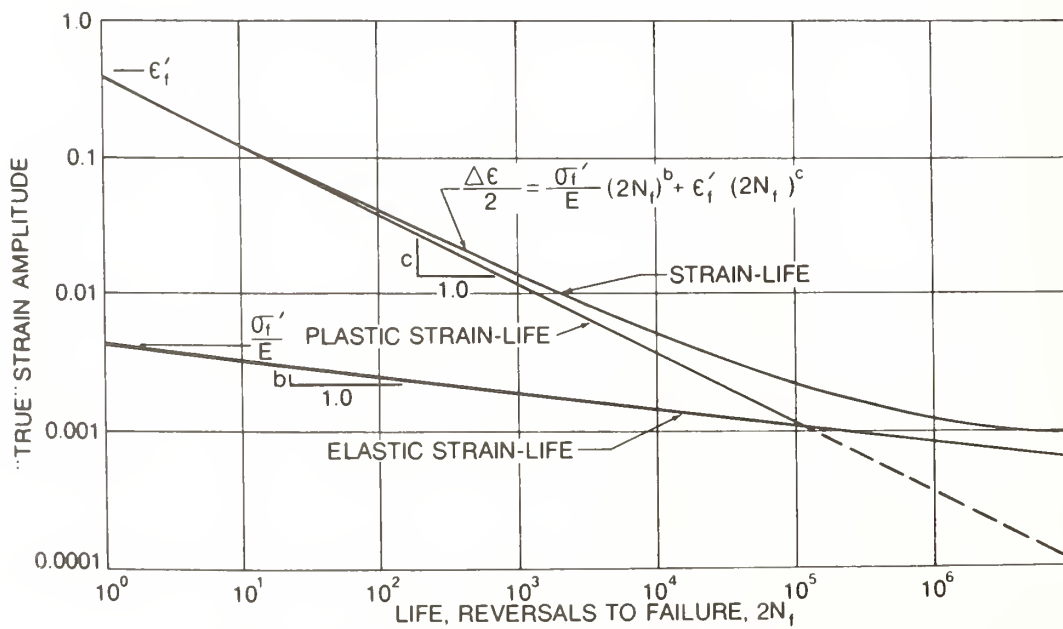

Figure 5. Strain amplitude versus reversals to failure, 1020 H. R. Steel. [1].

*maximum strain*,  $\epsilon_{\max}$ —the greatest algebraic value of strain in a cycle, tensile strain being considered positive and compressive strain negative.

*mean strain*,  $\epsilon_m$ —the algebraic average of the maximum and minimum strains in one cycle.

*minimum strain*,  $\epsilon_{\min}$ —the least algebraic value of strain in a cycle, tensile strain being considered positive and compressive strain negative.

*reversal*—the point at which the first derivative of the stress or strain-time function changes sign. For constant amplitude cycling, the number of reversals is equal to twice the number of cycles.

*strain amplitude*—one half the range of any strain cycle.

*strain range*,  $\Delta\epsilon$ —the algebraic difference between the maximum and minimum strains in one cycle.

Note—The strain range is often separated into elastic and plastic components. For many metals and alloys, the elastic strain range,  $\Delta\epsilon_e$ , is equal to the stress range divided by the modulus of elasticity with the plastic strain range,  $\Delta\epsilon_p$ , taken as the difference between the strain range and the elastic strain range (see 2.2).

*strain ratio*—the algebraic ratio of two specified strain values in a strain cycle. Two commonly used ratios are (a)  $A_e$ , the ratio of the strain amplitude to the mean strain, and (b)  $R_e$ , the ratio of the minimum strain to the maximum strain.

## Synonyms

*fatigue life*  
endurance

*fatigue limit*  
endurance limit  
endurance strength

*cycle ratio*  
fatigue ratio  
endurance ratio

*range of stress*  
stress range  
endurance range  
fatigue range

*fatigue notch factor*  
fatigue strength reduction factor

## Standard Test Methods

There are many test methods for studying fatigue behavior which have become broadly used over the years, among them:

- rotating testing – in which the specimen is bent about a neutral plane which rotates with respect to the test piece. The specimen may be subjected to 3 point, 4 point or cantilever loading
- plane bending – in which the specimen is repeatedly bent about a particular neutral plane
- torsion – in which the specimen is subjected to twisting in alternating directions about a fixed axis
- axial stressing – in which the material is uniaxially loaded and is cycled between tension and compression or between two levels of tension. Both stress and strain control of the cyclic amplitude are practiced

Curiously, although all the above testing techniques are widely practiced and results reported thereon, ASTM has written testing standards *only* for tests of the axial loading type:

- E466-82 Constant amplitude axial fatigue where strains are predominantly elastic both upon initial loading and throughout the test
- E606-80 Constant amplitude low cycle fatigue where strains may be inelastic but are not time dependent

Standards setting bodies in other countries have prepared standards for the other types of test, e.g., the Japanese JIS Z 2274 (1974), German DIN 50113, and British BS 3518, Pt.2 for rotating bending fatigue. Such tests are not in general correlatable with axially stressed tests as may be seen from figure 6.

Testing may also be complicated by the introduction of notches, multiaxial stressing, use of more elaborate loading regimes than simple sawtooth or sinusoidal—hold times, spectral loading simulative of service, etc., or the provision of creep and environmental conditions. Such matters are beyond the scope of this report.

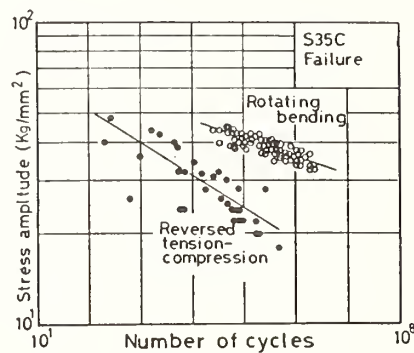

Figure 6. *S-N diagram retrieved in the condition of smooth bar specimen, S35C alloy in JIS Standard;  $\sigma_y = 20-50$  kg/mm<sup>2</sup>, in air, temperature = 0-30°, mean stress  $\sigma_m = 0$ , and rotating bending or axial loading [6]*

## Standards for Reporting Data

The sensitivity of fatigue behavior to numerous factors is such that a very detailed recording of these is essential to permit full analysis of the test results or intercomparison of two sets of experiments. These matters are covered in ASTM 468-82 (cyclic stress), ASTM 606-80 (cyclic strain) and are also discussed by Radziminski et al. [9] and by Uenishi et al. [6]. The pertinent factors desirable or essential to include with the test report comprise:

### *material*

- designation
- form and section size
- heat number and manufacturer
- melting practice
- thermal and mechanical processing
- chemical composition
- mechanical properties (hardness, tensile, and impact)
- microstructure

### *specimen*

- geometry and dimensions
- orientation relative to processing
- preparation technique
- surface condition
- theoretical stress concentration factor
- critical stress intensity factor

*testing*

- experimental design
- machine
- test method
- loading conditions
- frequency of loading (if other than a sinusoidal stress cycle is used, the shape should be described)
- ambient conditions

*test termination*

- criteria
  - crack incidence
  - crack propagation rate
  - total strain
  - failure
  - “run-out”
- location of fracture
- appearance of fracture

Presentation of the test results themselves may be tabular or graphical, either the common S-N curves or  $\epsilon$ -N curves or one form or another of the so-called constant life diagram. (Fig. 2.)

Increasingly, an analytical approach is being taken, especially for strain controlled testing. True strain can be viewed as the sum of an elastic component and a plastic component. It therefore can be shown [1] that each of these components of true strain amplitude,

$$\Delta\epsilon/2 = \Delta\epsilon_e/2 + \Delta\epsilon_p/2, \quad (4)$$

can be related to the number of reversals to failure ( $2N_f$ ) in a strain-controlled fatigue test, giving:

$$\Delta\epsilon/2 = (\sigma'_f/E)(2N_f)^b + \epsilon'_f(2N_f)^c \quad (5)$$

Thus four fatigue constants  $\sigma'_f$ ,  $\epsilon'_f$ , b, c and the elastic modulus can describe the whole of fatigue life, both low cycle and long-life data. This set of constants, therefore constitutes the preferred parameters for characterizing fatigue behavior.

A useful discussion of data requirements for characterizing the fatigue behavior of a material, including fatigue data analysis, combining data from multiple sources and regression analysis of fatigue data is presented in Mil Handbook 5 [11].

## Precision and Accuracy

Fatigue is intrinsically a probabilistic phenomenon and is further complicated by extraordinary sensitivity to a large number of factors as just reviewed. It is therefore not surprising that a substantially larger coefficient of variation (the standard deviation divided by the mean value) is experienced with fatigue data than with other mechanical properties. Some representative results are shown in table 1.

**Table 1.** *Coefficients of variation experienced in testing for mechanical properties [5].*

<i>Mechanical Property</i>	<i>Coefficient of Variation</i>
Elastic Modulus	0.03
Ultimate Tensile Strength	0.05
Brinell Hardness	0.05
Tensile Yield Strength	0.07
Fracture Toughness	0.07
Fatigue Strength	0.08 to 1.0

Another view of the typical scatter to be expected is afforded by the histogram of figure 7 for 300 parts in 25 lots of a spring steel, 5160H. The coefficient of variation for this set of experiments was 0.28 in terms of fatigue life; naturally, near the fatigue limit this approach is meaningless and coefficient of variation there should be calculated for the fatigue limit. Generally speaking, the scatter in fatigue data tends to increase with increasing

strength, decreasing purity and homogeneity and decreasing sample size. A special standard practice (E739-80) has been issued by ASTM for statistical analysis of linear or linearized stress-life or strain-life fatigue data.

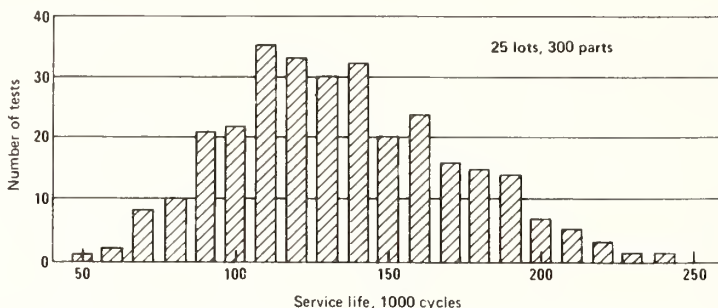

Figure 7. Distribution of fatigue lifetimes. Results of simulated service tests of front suspension torsion bar springs of 5260H steel. Size of hexagonal bar section was 32 mm (1.25 in). Mean service life 134,000 cycles; standard deviation 37,000 cycles; coefficient of variation 0.28 (after Boardman [5]).

### Correlations

The correlation between monotonic properties of materials and their cyclic behavior depends on whether we are considering alternating stress loading (usually elastic) or alternating strain loading (predominantly plastic). A good correlation is often obtained for alternating stress tests between the fatigue limit and the tensile strength as shown in figure 8. Low cycle (high stress, strain control) fatigue data tend to relate more to the ductility of the material than to its strength. Apart from these crude empirical generalizations it is not yet possible to predict fatigue behavior from simpler and quicker tests. The lack of good correlations between the various types of fatigue tests has already been cited.

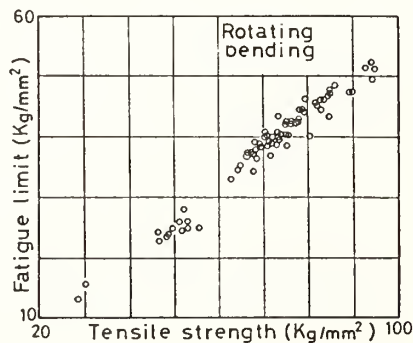

Figure 8. Relation of tensile strength and fatigue limit retrieved in the condition of carbon steel, smooth bar specimen, in air, temperature = 0–30°, and rotating bending (after Uenishi et al. [6]).

### References

- [1] \_\_\_\_\_, "Technical Report on Fatigue Properties," SAE J1099 Society of Automotive Engineers (1977).
- [2] Graham, J. A., ed., "Fatigue Design Handbook," Society of Automotive Engineers, Inc., 400 Commonwealth Drive, Warrendale, PA 15096 (1968).
- [3] Jaske, C. E., Feddersen, C. E., Davies, K. B., Rice, R. C., "Analysis of Fatigue, Fatigue Crack Propagation and Fracture Data," NASA CR 13233. Battelle-Columbus Labs, Columbus, OH (Nov. 1973).
- [4] Sandor, B. I., "Fundamentals of Cyclic Stress and Strain," U. Wisconsin Press, Madison, WI.
- [5] Boardman, B. E., "Fatigue Resistance of Steels," fm. *ASM Metals Handbook* 9th ed., p. 665, American Society for Metals, Metals Park, OH (1978).



- [6] Uenishi, M., et al., "Computer Program System for Fatigue Strength Analysis," *J. Jap. Soc. for Metals* (1980) 1108.
- [7] Koehler, J., Heckel, K., and Munich, T. U., "Scatter and Statistical Size Effect in the Fatigue Behavior of Metallic Specimens," *Proc. 2nd Int. Conf. on Mechanical Behavior of Materials*, ASM (1980) 193.
- [8] \_\_\_\_\_, "NRRIM Fatigue Data Sheet Series," National Research Institute for Metals, Tokyo, Japan (1978-).
- [9] Radzinski, J. B., et al., "Fatigue Data Bank and Data Analysis Investigation," U. Illinois Report, NTIS PB-240261, June 1973.
- [10] Dabell, B. J., and Hill, S. J., "The Use of Computers in Fatigue Design and Development," *Int. J. of Fatigue* 1 (1979) 29.
- [11] \_\_\_\_\_, *Military Standardization Handbook, 5C, "Metallic Materials and Elements for Aerospace Vehicle Structures,"* 15 Sept. 1976, 2 vols with later supplements.
- [12] Swanson, S., ed., "Handbook of Fatigue Testing," ASTM STP 566 (1974) 232 pp.
- [13] Thomas, G. B. "Standards for High Temperature Fatigue" in "Measurement of High Temperature Mechanical Properties of Metals," Loveday, M. S., Day, M. F. and Dyson, B. F. eds., National Physical Laboratory (1982).
- [13] Coffin, L. F. "Overview of Temperature and Environmental Effects on Fatigue of Structural Metals," *Proc. 27th Sagamore Army Materials Research Conf.* (1982).



U.S. DEPT. OF COMM. <b>BIBLIOGRAPHIC DATA SHEET</b> <i>(See instructions)</i>	1. PUBLICATION OR REPORT NO. NBS/SP-702	2. Performing Organ. Report No.	3. Publication Date August 1985
4. TITLE AND SUBTITLE STANDARDS AND METADATA REQUIREMENTS FOR COMPUTERIZATION OF SELECTED MECHANICAL PROPERTIES OF METALLIC MATERIALS			
5. AUTHOR(S) J. H. Westbrook			
6. PERFORMING ORGANIZATION <i>(If joint or other than NBS, see instructions)</i> <del>NATIONAL BUREAU OF STANDARDS</del> <del>DEPARTMENT OF COMMERCE</del> <del>WASHINGTON, D.C. 20234</del> General Electric Corporation Materials Information Services 120 Erie Boulevard Schenectady, NY		7. Contract/Grant No.	8. Type of Report & Period Covered Final
9. SPONSORING ORGANIZATION NAME AND COMPLETE ADDRESS <i>(Street, City, State, ZIP)</i> U.S. Army DARCOM                      NBS Code DRCLD                              Office of Standard Reference Data 5001 Eisenhower Avenue              A323 Physics Building Alexandria, VA 22333                  Gaithersburg, MD 20899			
10. SUPPLEMENTARY NOTES Library of Congress Catalog Card Number: 85-600585 <input type="checkbox"/> Document describes a computer program; SF-185, FIPS Software Summary, is attached.			
11. ABSTRACT <i>(A 200-word or less factual summary of most significant information. If document includes a significant bibliography or literature survey, mention it here)</i> To assist in building a computerized information system on the engineering properties of materials, the standards and metadata requirements for a representative group of mechanical property categories are considered. These categories include: tensile behavior, hardness numbers, notch-bar impact test parameters, and fatigue properties. For each property group, definitions of terms, synonyms (and non-synonyms), standard test methods, standards for reporting data, precision and accuracy, and correlations of properties are addressed. The principal findings and recommendations are as follows. Existing test methods are generally adequate for the properties considered, but better standards are needed for data reporting. Appraisal of materials variability and testing machine variability would be assisted by access to standard reference materials, certified as to their mechanical properties. All properties considered for inclusion in a computerized system can be categorized as parameters for direct search, parameters retrievable with extraction of all data stored for a given material, and parameters which are derived from an analytical representation of experimental data. Drafting of some general standards on computerized file structures and metadata files suitable for the engineering field is advised.			
12. KEY WORDS <i>(Six to twelve entries; alphabetical order; capitalize only proper names; and separate key words by semicolons)</i> computerized materials data; fatigue; hardness; materials data; materials metadata; materials property; mechanical properties; notch-bar impact test; tensile behavior; tensile strength			
13. AVAILABILITY <input checked="" type="checkbox"/> Unlimited <input type="checkbox"/> For Official Distribution. Do Not Release to NTIS <input checked="" type="checkbox"/> Order From Superintendent of Documents, U.S. Government Printing Office, Washington, D.C. 20402. <input type="checkbox"/> Order From National Technical Information Service (NTIS), Springfield, VA. 22161		14. NO. OF PRINTED PAGES 47	15. Price







# NBS *Technical Publications*

## *Periodical*

---

**Journal of Research**—The Journal of Research of the National Bureau of Standards reports NBS research and development in those disciplines of the physical and engineering sciences in which the Bureau is active. These include physics, chemistry, engineering, mathematics, and computer sciences. Papers cover a broad range of subjects, with major emphasis on measurement methodology and the basic technology underlying standardization. Also included from time to time are survey articles on topics closely related to the Bureau's technical and scientific programs. Issued six times a year.

## *Nonperiodicals*

---

**Monographs**—Major contributions to the technical literature on various subjects related to the Bureau's scientific and technical activities.

**Handbooks**—Recommended codes of engineering and industrial practice (including safety codes) developed in cooperation with interested industries, professional organizations, and regulatory bodies.

**Special Publications**—Include proceedings of conferences sponsored by NBS, NBS annual reports, and other special publications appropriate to this grouping such as wall charts, pocket cards, and bibliographies.

**Applied Mathematics Series**—Mathematical tables, manuals, and studies of special interest to physicists, engineers, chemists, biologists, mathematicians, computer programmers, and others engaged in scientific and technical work.

**National Standard Reference Data Series**—Provides quantitative data on the physical and chemical properties of materials, compiled from the world's literature and critically evaluated. Developed under a worldwide program coordinated by NBS under the authority of the National Standard Data Act (Public Law 90-396).

NOTE: The Journal of Physical and Chemical Reference Data (JPCRD) is published quarterly for NBS by the American Chemical Society (ACS) and the American Institute of Physics (AIP). Subscriptions, reprints, and supplements are available from ACS, 1155 Sixteenth St., NW, Washington, DC 20056.

**Building Science Series**—Disseminates technical information developed at the Bureau on building materials, components, systems, and whole structures. The series presents research results, test methods, and performance criteria related to the structural and environmental functions and the durability and safety characteristics of building elements and systems.

**Technical Notes**—Studies or reports which are complete in themselves but restrictive in their treatment of a subject. Analogous to monographs but not so comprehensive in scope or definitive in treatment of the subject area. Often serve as a vehicle for final reports of work performed at NBS under the sponsorship of other government agencies.

**Voluntary Product Standards**—Developed under procedures published by the Department of Commerce in Part 10, Title 15, of the Code of Federal Regulations. The standards establish nationally recognized requirements for products, and provide all concerned interests with a basis for common understanding of the characteristics of the products. NBS administers this program as a supplement to the activities of the private sector standardizing organizations.

**Consumer Information Series**—Practical information, based on NBS research and experience, covering areas of interest to the consumer. Easily understandable language and illustrations provide useful background knowledge for shopping in today's technological marketplace.

*Order the above NBS publications from: Superintendent of Documents, Government Printing Office, Washington, DC 20402.*

*Order the following NBS publications—FIPS and NBSIR's—from the National Technical Information Service, Springfield, VA 22161.*

**Federal Information Processing Standards Publications (FIPS PUB)**—Publications in this series collectively constitute the Federal Information Processing Standards Register. The Register serves as the official source of information in the Federal Government regarding standards issued by NBS pursuant to the Federal Property and Administrative Services Act of 1949 as amended, Public Law 89-306 (79 Stat. 1127), and as implemented by Executive Order 11717 (38 FR 12315, dated May 11, 1973) and Part 6 of Title 15 CFR (Code of Federal Regulations).

**NBS Interagency Reports (NBSIR)**—A special series of interim or final reports on work performed by NBS for outside sponsors (both government and non-government). In general, initial distribution is handled by the sponsor; public distribution is by the National Technical Information Service, Springfield, VA 22161, in paper copy or microfiche form.

**U.S. Department of Commerce**  
National Bureau of Standards  
Gaithersburg, MD 20899

Official Business  
Penalty for Private Use \$300