

Fire Research Information Services
National Bureau of Standards
Bldg. 225, Rm. A46
Washington, D.C. 20234

Handwritten:
R7700907

NATIONAL BUREAU OF STANDARDS REPORT

4869

QUARTERLY REPORT

ON

EVALUATION OF REFRACTORY QUALITIES OF
CONCRETES FOR JET AIRCRAFT WARM-UP, POWER CHECK,
MAINTENANCE APRONS, AND RUNWAYS

by

W. L. Pendergast, E. C. Tuma, L. E. Mong
and R. A. Clevenger

Approved for public release by the
Director of the National Institute of
Standards and Technology (NIST)
on October 9, 2015.



U. S. DEPARTMENT OF COMMERCE
NATIONAL BUREAU OF STANDARDS

U. S. DEPARTMENT OF COMMERCE

Sinclair Weeks, *Secretary*

NATIONAL BUREAU OF STANDARDS

A. V. Astin, *Director*



THE NATIONAL BUREAU OF STANDARDS

The scope of activities of the National Bureau of Standards at its headquarters in Washington, D. C., and its major field laboratories in Boulder, Colorado, is suggested in the following listing of the divisions and sections engaged in technical work. In general, each section carries out specialized research, development, and engineering in the field indicated by its title. A brief description of the activities, and of the resultant reports and publications, appears on the inside back cover of this report.

WASHINGTON, D. C.

Electricity and Electronics. Resistance and Reactance. Electron Tubes. Electrical Instruments. Magnetic Measurements. Process Technology. Engineering Electronics. Electronic Instrumentation. Electrochemistry.

Optics and Metrology. Photometry and Colorimetry. Optical Instruments. Photographic Technology. Length. Engineering Metrology.

Heat and Power. Temperature Measurements. Thermodynamics. Cryogenic Physics. Engines and Lubrication. Engine Fuels.

Atomic and Radiation Physics. Spectroscopy. Radiometry. Mass Spectrometry. Solid State Physics. Electron Physics. Atomic Physics. Nuclear Physics. Radioactivity. X-rays. Betatron. Nucleonic Instrumentation. Radiological Equipment. AEC Radiation Instruments.

Chemistry. Organic Coatings. Surface Chemistry. Organic Chemistry. Analytical Chemistry. Inorganic Chemistry. Electrodeposition. Gas Chemistry. Physical Chemistry. Thermochemistry. Spectrochemistry. Pure Substances.

Mechanics. Sound. Mechanical Instruments. Fluid Mechanics. Engineering Mechanics. Mass and Scale. Capacity, Density, and Fluid Meters. Combustion Controls.

Organic and Fibrous Materials. Rubber. Textiles. Paper. Leather. Testing and Specifications. Polymer Structure. Organic Plastics. Dental Research.

Metallurgy. Thermal Metallurgy. Chemical Metallurgy. Mechanical Metallurgy. Corrosion.

Mineral Products. Ceramic Engineering. Porcelain and Pottery. Glass. Refractories. Enameled Metals. Concreting Materials. Constitution and Microstructure.

Building Technology. Structural Engineering. Fire Protection. Heating and Air Conditioning. Floor, Roof, and Wall Coverings. Codes and Specifications.

Applied Mathematics. Numerical Analysis. Computation. Statistical Engineering. Mathematical Physics.

Data Processing Systems. Components and Techniques. Digital Circuitry. Digital Systems. Analogue Systems. Applications Engineering.

● Office of Basic Instrumentation

● Office of Weights and Measures

BOULDER, COLORADO

Cryogenic Engineering. Cryogenic Equipment. Cryogenic Processes. Properties of Materials. Gas Liquefaction.

Radio Propagation Physics. Upper Atmosphere Research. Ionospheric Research. Regular Propagation Services.

Radio Propagation Engineering. Frequency Utilization Research. Tropospheric Propagation Research.

Radio Standards. High Frequency Standards Branch: High Frequency Electrical Standards. Radio Broadcast Service. High Frequency Impedance Standards. Microwave Standards Branch: Extreme High Frequency and Noise. Microwave Frequency and Spectroscopy. Microwave Circuit Standards.

NATIONAL BUREAU OF STANDARDS REPORT

NBS PROJECT

NBS REPORT

0903-20-4428

October 5, 1956

4869

QUARTERLY REPORT
ON
EVALUATION OF REFRACTORY QUALITIES OF
CONCRETES FOR JET AIRCRAFT WARM-UP, POWER CHECK,
MAINTENANCE APRONS, AND RUNWAYS

by

W. L. Pendergast, E. C. Tuma, L. E. Mong
and R. A. Clevenger

Refractories Section
Mineral Products Division

Sponsored by
Department of the Navy
Bureau of Yards and Docks

Reference: NT4-59/NY 420 008-1
NBS File No. 9.3/1134-C

Approved:
Dr. Samuel Zerfoss
Chief, Refractories Section



U. S. DEPARTMENT OF COMMERCE
NATIONAL BUREAU OF STANDARDS

The publication, or
unless permission
25, D. C. Such pe
cially prepared if

Approved for public release by the
Director of the National Institute of
Standards and Technology (NIST)
on October 9, 2015.

In part, is prohibited
standards, Washington
eport has been specifi-
report for its own use.

QUARTERLY REPORT
ON
EVALUATION OF REFRACTORY QUALITIES OF
CONCRETES FOR JET AIRCRAFT WARM-UP, POWER CHECK,
MAINTENANCE APRONS, AND RUNWAYS

1. INTRODUCTION

This phase of the project includes the determination of the cause or causes of failure that occur in concrete aprons and runways exposed to jet exhaust gases. A combustion chamber that delivers hot gases at velocities and temperatures approximating those of field conditions is being used. The approach includes instrumentation of the concrete test panels to determine the heat gradients and stresses set up during flame impingement at several locations on the test area and at varying depths below the surface.

2. ACTIVITIES

An Advisory Group, formed for the guidance in furthering the study of pavements resistant to the action of jet and rocket exhaust, at a meeting, held at the Ohio River Division Laboratories, suggested that a crushed rock of fine grained texture might be used to advantage as an aggregate in such concretes. A survey of rock deposits resulted in the selection of a diabase from Centerville, Virginia. Figure 1 is a photomicrograph of a thin section of this diabase between crossed nicols. Interlaced bladed grains of feldspar and the dark mineral pyroxene hornblende are apparent. The rock has a low porosity and is practically quartz free. The latter two items offer much promise for a stable nonabsorbent aggregate. This material has been substituted for olivine formerly included in the list of aggregates under study. Three tons of this diabase has been received. The material was crushed on receipt,

1. The first part of the document discusses the importance of maintaining accurate records of all transactions.

Section 2

2. The second part of the document details the various methods used to collect and analyze data from different sources.

Section 3

3. The third part of the document describes the results of the analysis and the implications of the findings.



Figure 1. Photomicrograph (150 X) (Crossed nicols) Showing Feldspar and Pyroxene grains [practically no quartz] in a Diabase from Centerville, Virginia.



however, a screen analysis indicated that additional sizing would be necessary to obtain the desired fineness moduli for the coarse and fine aggregate. The results of such preliminary tests on the aggregate as Los Angeles abrasion test, bulk specific gravity of coarse and fine, percent absorption of coarse and fine indicate that a concrete could be designed that would develop the required flexural strength using the same percentages of coarse and fine aggregate, same cement content, and water-cement ratio as reported for concretes using Bluestone aggregate, NBS Report No. 2832, September 30, 1953, Table II (P-BS-1, 2 or 3). A batch of this design has been mixed and five test panels, 18 x 18 x 6 inches, together with other test specimens, were fabricated and are being cured.

A series of five test panels were subjected to the jet blast during the period covered by this report. These panels were fabricated with concrete designed using crushed olivine aggregate and portland cement. All were cured for 28 days in the fog-room and tested after storing at 73°F and 50 percent relative humidity for 14, 28, 42, 56, and 70 days. Due to the rapid destruction of the test area the usual five-minute interval of test was reduced to 1, 1, 2, 3, and 3 minutes respectively. Even with this modified time of impingement the six-inch diameter test area of each panel was spalled away. The depth of the cavity at the center of the test area reaching two inches.

Additional work was done in an effort to determine the effect of the water absorbed by the aggregate during the soaking and curing periods on the resistance of the concrete after partial drying. Three



sets, each set comprising of one sample (+ No. 1 screen) of each of the four aggregate olivine, White Marsh gravel, crushed building brick, and diabase, were dried at 110° to constant weight. One set was immersed in a water repellent silicone resin for 24 hours, dried at room temperature and immersed in water till tested. A second set received the drying treatment only and was stored in desiccator till tested. A third set was saturated and immersed in water till tested. All specimens were exposed to the jet blast (1200°F - 1200 ft/sec. velocity) for two minutes. The quartzite (White Marsh) specimens all cracked badly, the cracks eminenting from the original irregular surface fractures. The specimens of olivine and building brick treated by immersion in water cracked, especially the olivine which sugared, but previously dried specimens withstood the test. Water-proofed specimens of brick and olivine did not crack in the jet blast tests. There was no indication of failure in any set of the diabase particles.

A study of the concentration of water in concrete during curing and drying is being continued. The three variables, type of aggregate, cement content, and mixing water, involved in the composition of concrete are factors in the concentration of water in concrete during curing and drying. The drying of tile shape specimens, three by three inches, having different thicknesses has been continued. The one-half-inch thick specimens, vapor proofed on all but one three by three inch face have reached water equilibrium in an atmosphere of 73°F and 50 percent relative humidity. The thicker specimens continue to lose weight even after a four month exposure.



Additional specimens have been fabricated using separately weighed batches for each specimen. This was done to eliminate possible variation in composition which may have occurred in the first set of specimens all cast from the same batch. Such variations were indicated by anomalous results.

A second set of tile specimens have been fabricated. This set was made in two series similar in shape and size to the set under study but one tile of each thickness was cast with a cavity. The dimensions of the specimens and positions of the cavities are given in Figure 2. All specimens are now in the fourth week of the curing period. The weight and volume changes of the specimens have been determined at seven-day intervals.

The relative humidities in the cavities, indicated in Figure 2, will be determined during the drying cycle by means of a hygrometer illustrated in Figure 2. These miniature ceramic hygrometer sensing elements are $3/8" \times 3/8" \times 1/4"$. They have a range of 50 to 99 percent relative humidity and are calibrated for use with an electric hygrometer indicator. It is planned to correlate humidity and weight loss during the drying period especially in the specimen of one and one and one-half thickness. The variations in humidity with the depth below the exposed face, after various drying intervals, will also be determined. Similar studies have been reported by Menzel.^{1/} The miniature size of these hygrometers, furnished by the American Instrument Company, will facilitate a more critical study.

^{1/}
"A Method for Determining the Moisture Condition of Hardened Concrete in Terms of Relative Humidity," Reprint of the Proceedings of the A.S.T.M., Vol. 55, 1955, Portland Cement Association Bulletin D-4.



No. of cavity	Specimen thickness A (inches)	Distance from exposed face to cavity B (inches)
1	1	$\frac{1}{4}$
1	$1\frac{1}{2}$	$\frac{1}{2}$
2	2	$\frac{1}{4}, 1\frac{1}{4}$
3	4	$\frac{1}{2}, 1\frac{1}{2}, 2\frac{1}{2}$
5	6	$\frac{1}{4}, 1\frac{1}{4}, 2\frac{1}{2}, 3\frac{1}{2}, 4\frac{1}{2}$

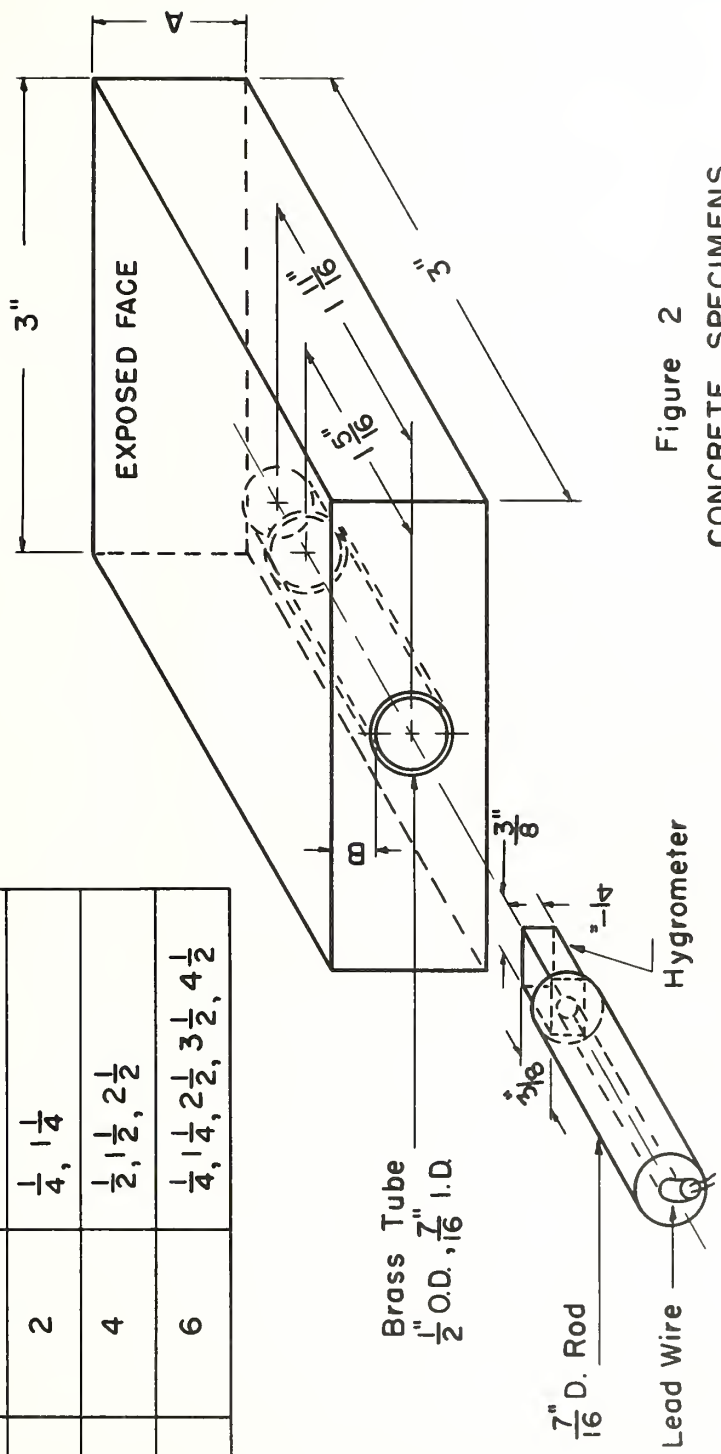

Figure 2
CONCRETE SPECIMENS
FOR
HUMIDITY STUDIES

3. DISCUSSION OF STEAM PRESSURE AS A FACTOR IN THE FAILURE OF CONCRETE IN THE JET IMPINGEMENT TEST

The measurement of water vapor pressure developed in a concrete specimen during heating is being considered. While pressures developed by water alone can be obtained from the steam tables, the temperatures for the same pressure may be altered greatly in concrete by the chemical bonding of water with the cementing material.^{2/} The pressure-temperature relation for water in concrete would be expected to be a factor in the disintegration of concrete during heating along with other factors such as strength, thermal stresses, thermal conductivity, heat capacity, and permeability to fluid flow. Most of these properties have essentially constant values, but permeability may vary over a wide range and affect the extent of the steam pressure developed. The purpose of the experimental work would be to obtain some measure of the net pressure resulting from the relief by fluid flow of the total pressure developed in the pressure-temperature relation.

The significance of the forces resulting from volatilization of water in fracturing concrete during heating is evident from the jet impingement tests. In these tests, fractures occur at temperatures in the range of water evolution rather than in the higher ranges where thermal spalling stresses are developed by non-uniform thermal gradients. An exception to this is the concrete made of White Marsh gravel whose larger particles alone may spall in the lower temperature range even when the sample is dry.

^{2/} "Studies of the Physical Properties of Hardened Portland Cement Paste," T. C. Powers and T. L. Brownyard Research Laboratories of the Portland Cement Association, Journal American Concrete Institute, Vol. 43, 101, October-April 1947.

In order to develop a sufficiently large steam pressure to cause fracture of the concrete during heating, the supply of available water and rate of evolution must overbalance the flow of steam to the surface. The importance of permeability and the rate of heating in setting up this condition is evident.

The factors affecting water permeability of cement paste and rocks has been discussed by Powers et al.^{2/} The factors of interest here were:

- 1) Permeability decreases approximately 1 million times during setting and curing of portland cement. Low permeabilities were obtained after 24 days.
- 2) Permeability increases rapidly for the high W/C ratios, and the rate changes rapidly at about a W/C = .45.
- 3) Coefficients of permeability were extremely small for cured cements and ranged from approximately 5 to 75×10^{-12} cm per sec.
- 4) Gentle drying (208 days at 93 percent relative humidity, 1,040 days at 79 percent relative humidity, and 238 days at 100 percent relative humidity) increased the permeability about 70 times.
- 5) Permeabilities of 12 kinds of rocks, often used as aggregates (traprock, quartzitic types, limestone, sandstone, granite), were in the range of the permeabilities of pastes having a W/C ratios from .38 to .71.
- 6) The amount of evaporable water in a paste, having the same permeability as a given rock, was from 10 to 30 times more than in the rock.

^{2/} "Permeability of Portland Cement Paste", T. C. Powers, L. E. Copeland, J. C. Hayes and H. M. Mann. PCA Research Dept. Bulletin 53, April 1955, Journal American Concrete Institute, Proceedings 51, 285 (1955).

These data indicated that:

- 1) The cured cement paste and aggregate of the concrete have about the same low permeabilities.
- 2) Drying greatly increases the permeability of the paste; and this finding is in accordance with the lack of spalling in the jet impingement tests on dried concrete slabs.
- 3) The use of portland cement as a cementing material in concrete necessarily introduces the major part of the destructive water for the jet impingement tests.
- 4) The major improvement in performance of the concrete slab in the jet impingement test would result from a large increase in the permeability of the cured and treated cement paste which constitutes the continuous phase.
- 5) A minor improvement in performance would be expected from a large increase in the permeability of the aggregate.

3.1 Plans for Next Quarter

It is possible that the steam pressure generated in concrete may not be so high that it necessarily causes failure. It is suggested that the pressure-temperature relation of concrete and water mixture be determined. The determination of this relation at several rates of heating may give some data on the thermal gradient and temperature at fracture. The concrete would be placed in a bomb having temperature and pressure indicators. A better procedure would be the determination of pressures within the concrete during the jet impingement test, but miniature pressure-sensing elements for such studies have not been developed.

THE NATIONAL BUREAU OF STANDARDS

Functions and Activities

The functions of the National Bureau of Standards are set forth in the Act of Congress, March 3, 1901, as amended by Congress in Public Law 619, 1950. These include the development and maintenance of the national standards of measurement and the provision of means and methods for making measurements consistent with these standards; the determination of physical constants and properties of materials; the development of methods and instruments for testing materials, devices, and structures; advisory services to Government Agencies on scientific and technical problems; invention and development of devices to serve special needs of the Government; and the development of standard practices, codes, and specifications. The work includes basic and applied research, development, engineering, instrumentation, testing, evaluation, calibration services, and various consultation and information services. A major portion of the Bureau's work is performed for other Government Agencies, particularly the Department of Defense and the Atomic Energy Commission. The scope of activities is suggested by the listing of divisions and sections on the inside of the front cover.

Reports and Publications

The results of the Bureau's work take the form of either actual equipment and devices or published papers and reports. Reports are issued to the sponsoring agency of a particular project or program. Published papers appear either in the Bureau's own series of publications or in the journals of professional and scientific societies. The Bureau itself publishes three monthly periodicals, available from the Government Printing Office: The Journal of Research, which presents complete papers reporting technical investigations; the Technical News Bulletin, which presents summary and preliminary reports on work in progress; and Basic Radio Propagation Predictions, which provides data for determining the best frequencies to use for radio communications throughout the world. There are also five series of nonperiodical publications: The Applied Mathematics Series, Circulars, Handbooks, Building Materials and Structures Reports, and Miscellaneous Publications.

Information on the Bureau's publications can be found in NBS Circular 460, Publications of the National Bureau of Standards (\$1.25) and its Supplement (\$0.75), available from the Superintendent of Documents, Government Printing Office. Inquiries regarding the Bureau's reports and publications should be addressed to the Office of Scientific Publications, National Bureau of Standards, Washington 25, D. C.

