

REFERENCE

NBS  
PUBLICATIONS



NBSIR 83-1681

# Interim Progress Report: MATERIALS SELECTION CRITERIA FOR CRACK ARRESTER STRAKES IN NAVAL VESSELS

---

R.B. King

National Bureau of Standards  
U.S. Department of Commerce  
Boulder, Colorado 80303

January 1983

QC  
100  
.U56  
83-1681  
1983



NBSR  
26100  
1056  
10.83-1  
1983

NBSIR 83-1681

# Interim Progress Report: MATERIALS SELECTION CRITERIA FOR CRACK ARRESTER STRAKES IN NAVAL VESSELS

---

R.B. King

Fracture and Deformation Division  
National Measurement Laboratory  
National Bureau of Standards  
U.S. Department of Commerce  
Boulder, Colorado 80303

January 1983

Sponsored by:  
Naval Sea Systems Command (SEA 95R15)

Directed by:  
David Taylor Naval Ship R&D Center



---

U.S. DEPARTMENT OF COMMERCE, Malcolm Baldrige, Secretary

NATIONAL BUREAU OF STANDARDS, Ernest Ambler, Director



Interim Progress Report: MATERIALS SELECTION CRITERIA FOR CRACK ARRESTER  
STRAKES IN NAVAL VESSELS

R. B. King  
Fracture and Deformation Division  
National Bureau of Standards  
Boulder, Colorado 80303

Research has been conducted on the problem of developing quantitative criteria for materials selection for crack arrester strakes in naval vessels. Quantitative analysis of material performance in service requires application of dynamic elastic-plastic fracture mechanics. Results of an extensive literature survey in the area of dynamic fracture mechanics with specific attention given to the crack arrest application are presented. The research program that has been developed is described in detail.

Key words: crack arrest; crack propagation; dynamic fracture mechanics; elastic-plastic fracture mechanics; materials selection; toughness.

## 1. Introduction

In structures where the initiation of crack extension cannot be prevented, crack arrest becomes a vital line of defense for the prevention of catastrophic failure. In naval vessels the design strategy for ensuring crack arrest is to provide high toughness strakes at key locations in the ship's hull. After an event occurs which causes initiation of a running crack in the hull, the crack will propagate until it encounters an arrest strake. The high toughness of the strake is intended to cause the crack to arrest. Criteria for selection of materials for arrester strakes are needed.

Existing criteria for materials selection, based on experimental procedures such as the drop weight test [1] and the explosion-bulge test [2], are qualitative in nature. They provide a means for assessing the performance of a steel relative to that of other steels, and were the basis for selection of HY80 for use in crack arrester stakes. Quantitative criteria for materials selection are desirable because they would potentially permit substitution of other steels for HY80 while still giving assurance of adequate crack arrest performance in service. The overall objective of the NBS research program is to develop such quantitative materials selection criteria for crack arrester stakes.

Development of materials selection criteria for crack arrester stakes requires an understanding of the phenomenon of rapid crack propagation and how it is terminated when the crack encounters a ductile material (i.e. the arrester strake). Fracture in high-toughness steels is accompanied by extensive plastic deformation. In fact, such deformation likely contributes substantially to the dissipation of crack energy which accompanies arrest. Thus, it is outside the realm of linear elastic fracture mechanics (LEFM) and must be studied using elastic-plastic fracture mechanics (EPFM). As will become apparent, the application of elastic-plastic fracture mechanics to

the dynamic phenomenon of rapid crack propagation is in its infancy, and there is a need for combined experimental and analytical approach to the problem. Extensive instrumentation will be used to provide adequate characterization of the arrest event, and finite element analysis techniques will be used to model the tests. The specific objectives of the research program are: 1) develop a test method for studying the crack propagation and arrest event under conditions simulating those actual ship structures, 2) develop instrumentation capability to permit thorough experimental investigation of dynamic elastic-plastic crack propagation and arrest, 3) develop an analytical capability for modelling dynamic elastic-plastic crack propagation, 4) formulate materials selection criteria to ensure adequate performance in the arrester strake application.

This is a progress report on this program. First, the results of a literature survey that has been conducted on material relevant to crack arrest in high-toughness steels and the results of a literature survey on dynamic instrumentation are summarized. Then specific plans that have been developed for the NBS research program are discussed.

## 2. Literature Survey on Crack Arrest

An extensive survey has been conducted of literature concerned with crack arrest and the experimental techniques applicable to the crack arrest problem. Attention was limited to research that is relevant to the specific problem of crack arrest that occurs when a crack propagates in a relatively low toughness plate, and then through a weld into a high-toughness arrester plate.

Research, both experimental and theoretical, on the problem of dynamic fracture dates back to the 1950s, and it is difficult to categorize the considerable effort in this area. However, research relevant to the engineering problem of ensuring crack arrest by high-toughness strakes can be divided

into two broad categories, which will be referred to as the "small scale approach" and the "large-scale approach".

#### Small Scale Approach

An overview of the "small-scale approach", which has largely been followed in the United States, is given in [3]. Application of this approach to crack arrester strake design is discussed in [4]. In this approach, a parameter that represents a material property governing arrest is identified, and its value is measured from tests on relatively small specimens. (Typical specimen designs used in crack arrest studies are shown in fig. 1). To provide confidence in the approach, it is attempted to demonstrate that the critical value of the arrest-governing parameter is a geometry-independent material property by making measurements on different specimen configurations.

Research to date has been conducted within the framework of linear elastic fracture mechanics. The Griffith-Irwin-Orowan energy balance criterion is extended to the dynamic case as follows [3]: The total energy release rate associated with crack growth is

$$G = -1/B (dW/da + dU/da + dT/da) \quad (1)$$

where  $B$  is thickness at the crack tip,  $a$  is crack length, and  $U$ ,  $W$ ,  $T$  represent the potential energy of applied loads, strain energy, and kinetic energy, respectively. All irreversible processes (e.g., creation of new surfaces and plastic deformation) are assumed to occur in a small zone at the crack tip and to be characterized by a single parameter,  $R$ , which represents the resistance of the material to crack extension. The criterion for continued crack propagation is

$$G \geq R \quad (2)$$



and arrest will occur when the value of  $G$  becomes less than  $R$ . To account for high-strain-rate effects in the crack-tip region [5],  $R$  is assumed to be a function of crack speed. An equivalent fracture criterion can be expressed in terms of the stress intensity factor,  $K$ , which characterizes the singular deformation fields in the vicinity of the crack tip: crack propagation occurs when

$$K \geq K_D \quad (3)$$

and ceases when  $K < K_D$ . The equivalence between eq (1) and (2) can be established by a near tip evaluation of  $G$  [6], which results in

$$G = \frac{1-\nu^2}{E} A(\nu) K^2 \quad (4)$$

where  $A(\nu)$  is a geometry-independent function of crack speed,  $\nu$  is Poisson's ratio, and  $E$  is Young's modulus. Material toughness can thus be expressed by  $R$  or  $K_D$ . To completely characterize the arrest event, it is necessary to measure the functional dependence of  $R$  or  $K_D$  on velocity. A conservative simplification which is introduced is to characterize a material's toughness by the minimum value in a plot of  $K_D$  versus time, referred to as  $K_m$ .

A subset of the dynamic LEFM approach is a quasi-static approach based on the "arrest toughness,"  $K_a$  which is defined as the statically computed value of the stress intensity factor after arrest. Whether a quasi-static approach on the basis of  $K_a$  or a dynamic approach is superior is a controversial issue in the literature. The  $K_a$  approach has been advocated by Crosley and Ripling [7,8] based on their original experimental observation that the value of  $K_a$  appeared to be a reproducible material property. These authors present a great deal of experimental evidence that  $K_a$  is a material property that is independent of

specimen geometry and loading conditions [8]. On the other hand, experimental evidence also exists that shows that the predictions of a quasi-static theory are inaccurate in some circumstances [9]. An attempt has been made by Hahn et al to put this issue in perspective [3]. They argue that a significant amount of strain energy is converted to kinetic energy during crack propagation, and that the important factor is how much of this energy is reflected back from the boundaries of the body to be available for driving the crack. In a large structure or under short crack jumps, there is little time for kinetic energy return and  $K_m$  approaches  $K_a$ . In an infinite body, which has no kinetic energy return [10],

$$K_m = K_a \quad (5)$$

Eq (5) can be shown, in general, to give a lower bound estimate for  $K_m$ . The other extreme is a body that utilizes all of the kinetic energy as driving force. This extreme would be more closely approached in a small body or long crack jump. In this case it can be shown that the approximate relation

$$K_a = K_m^2 / K_q \quad (6)$$

holds [3], where  $K_q$  is the value of the stress intensity factor at initiation of fast fracture, which gives an upper bound estimate for  $K_m$ . The true situation will be intermediate between the static prediction of equation (5) and the fully dynamic prediction of eq (6).

Much research has been conducted towards measuring the toughness governing crack arrest, whether characterized by  $K_m$  or  $K_a$ . Small scale tests have been devised that employ a decaying stress field (induced by wedge loading) to

cause arrest, including the double cantilever beam (DCB) specimen [11] and the wedge-loaded compact-tension specimen [8]. In all toughness tests, the parameter  $K_m$  or  $K_a$  is not measured directly but must be inferred. (Exceptions are optical techniques that have been developed for measuring  $K$ , which are discussed below under instrumentation). The value of  $K_a$  can be computed from a static analysis of measurements of load-point displacement (which is the same for crack initiation and arrest for wedge loading) and final crack length.  $K_D$ , and hence  $K_m$ , is calculated from a fully dynamic analysis of the specimen using load-point displacement at initiation and final crack length as input. Dynamic analysis of the crack propagation process is extremely complicated. Although for some geometries, such as the double cantilever beam specimen, it is possible to develop a simplified one dimensional theory [12] in general it is necessary to solve the two-dimensional elastodynamic equations numerically.

Several drawbacks exist to the small scale approach described. The first is the lack of large-scale verification in tests that closely simulate actual service conditions. If the theory is correct, then knowledge of the arrest toughness of material used in arrester strakes will be sufficient to predict performance in service. A simplified procedure for applying dynamic LEFM to crack arrester strake evaluation is presented in [4], but to date the accuracy of dynamic LEFM predictions has not been verified. Other drawbacks are the problems associated with the restriction to LEFM. For the high toughness steels needed to ensure arrest in service, the crack propagation and arrest event is likely to be accompanied by a large amount of plasticity, thus invalidating LEFM or rendering it inaccurate. Evidence for the inadequacy of LEFM is presented in [13]:

1. Experimental results on direct evaluation of  $K_D$  by optical techniques show a significant geometry dependence.
2. Values of  $K_D$  obtained from a dynamic analysis under static loading gave incorrect predictions under impact loading.

Dahlberg et al. [14] have concluded that the specimen size conditions for validity of LEFM are more restrictive in the dynamic case than in the static case, and have shown numerically using finite element modeling that the plastic zone size accompanying rapid crack propagation can be quite large [15]. Another problem associated with the restriction to LEFM is the difficulty of measuring valid arrest toughness in high-toughness steels [1].

### Large-Scale Approach

The "large scale approach" was followed in earlier work in the United States and has been extensively pursued in Japan. Typical specimen configurations used in this approach are shown in figure 2. This differs from the small scale approach, apart from specimen size, in that test conditions more closely resemble actual service conditions.

Early work in the United States was motivated by brittle fracture of storage tanks [16]. Arrest can occur in storage tanks when initiation occurs in a locally embrittled zone and the crack propagates into tough surrounding material. There is a more gradual gradient in toughness in this application than in the case of crack arrester strakes in ships. This gradual gradient is simulated in the laboratory by using a temperature gradient in tests, such as the ESSO and Robertson tests.

A review of research on crack arrest in Japan was presented by Kanazawa [17]. Large scale tests have been used in that country primarily for two reasons. The first is for direct experimental development of design curves, such as stress as a function of temperature at arrest in various materials [18]. To simulate the conditions of arrest in a structure when a

crack encounters an arrester strake, the "hybrid double-tension" test has been employed [9,18-20]. In this test a brittle starter material is welded to a ductile arrester material. Initiation in the starter material is caused by a secondary loading fixture. The crack propagates out into a main stress field intended to simulate service stresses applied by the primary testing machine. There are drawbacks to the use of large-scale tests for direct design in this fashion. First, a substantial number of expensive tests are required. Second, there is a tendency to overgeneralize the results of these tests. Although they do simulate actual service, the conditions in these tests are not identical to those in an actual structure. Thus, for example, it may be reported on the basis of a large scale test that a given material at a certain temperature and stress level will arrest a running crack that has traveled a certain length [19]. It is not evident that these parameter values are geometry independent and therefore cannot be transferred directly to a structure, although the test results are used precisely in that fashion in design. The second purpose for large-scale tests has been verification of fracture mechanics predictions under conditions intended to simulate actual structural conditions, and it is this purpose that is directly relevant to the present study. An example is the study in reference 9: The toughnesses of various candidate materials for crack-arrester strake application were evaluated using a quasi-static analysis of ESSO test results. The performance of these materials was then predicted and compared with data obtained from large-scale tests in which a base starter material was butt welded to the arrester material. It was found from a static analysis that  $K_a$  was significantly lower in the large-scale tests than in the ESSO tests. It was necessary to introduce an empirically determined effective crack length to reduce the discrepancy between the predictions and experimental results. This may have been due to the neglect of dynamic effects in the analysis. This interpretation is

supported by the fact that quasi-static predictions were found to be accurate for relatively short crack-jump lengths, (less than approximately 200 mm) and inaccurate for larger lengths which agrees with the "kinetic energy returned" arguments discussed above. More recent work in Japan has taken dynamic effects into account in the analysis of experimental data. In reference 20 it was found that a reasonably geometry-independent  $K_D$ -vs.-velocity curve could be obtained for the materials studied, with good agreement between  $K_D$  from small-scale (DCB) test results and large-scale (double-tension type) results. This appears to provide verification of small-scale testing, at least for the specimen geometries and materials considered. Contradictory evidence concerning the validity of small-scale test results based on LEFM was presented above, however. Various other effects, including the influence of residual stresses, specimen length, and loading conditions on crack arrest have also been studied [17].

The large-scale approach has the advantage of providing verification of fracture mechanics predictions of crack-arrest behavior in specimen configurations, which simulate actual structural configurations. The drawbacks associated with restriction to LEFM have been present in the research conducted to date, as well as the additional problems discussed above caused by quasi-static analysis.

### Research On Dynamic Elastic-Plastic Fracture

Relatively little research has been conducted on elastic-plastic dynamic crack propagation. This is mainly because, as pointed out in reference 13, the static problem of elastic-plastic, slow, stable crack growth is not yet fully understood, and the generalization to the dynamic problem is difficult. Most of the contributions have been theoretical in nature. Several authors have investigated elastic-plastic effects using relatively simple modeling.

In strip-yield-type solutions, yielding is assumed to be confined to a line in front of the crack, and the physical crack is modeled as a longer crack with closure stresses acting on its faces in the yield zone. The strip-yield model was first proposed by Dugdale [21] for the static case and has been applied by Goodier and Field [22] and Kanninen [23] to the case of rapid crack propagation. This type of model has the advantage of being relatively simple, mathematically while still accounting for some of the main features of plasticity. For example, as a propagating crack approaches the interface with an arrester strake, the plastic zone in front of the crack will enter the strake, and the difference in flow properties between the material in the strake and the base metal may contribute to arrest. This effect could be accounted for in a strip-yield model. The notion of closure stresses, as used in the strip-yield models, has been applied to other plasticity effects. Hoagland, et al, [24] modeled the phenomenon of unbroken ductile ligaments behind the tip of a running brittle crack by placing closure forces on the faces of the crack in the model. Ogura [25] explained the apparent lowering of crack driving force for propagating cracks in ductile materials in which a significant amount of shear lip area is present by modeling the presence of shear lips as equivalent to closure stresses on the face of the crack.

Because of the mathematical complexities involved, more exact analytical treatment has so far been confined to the antiplane strain (mode III) case [26,27]. Mode III solution may permit qualitative conclusions to be drawn for the in-plane case by analogy and may provide guidance for numerical modeling, for example, by giving information about the nature of the singularity at the crack tip. An elastic-plastic finite-element calculation of dynamic crack propagation was presented by Dahlberg [15]. In his numerical simulation of an edge-cracked panel in tension, he found a significant plastic zone exists in the crack tip region as well as a large plastic wake.

Accounting for plastic energy dissipation outside the crack-tip zone by including an additional term in equation (1) reduced the crack driving force approximately in half. The results of the modeled experiment for toughness as a function of crack velocity were in serious disagreement with results for the same material from a valid LEFM experiment when the dissipation effects were neglected. Including the plastic energy dissipation term explained the discrepancies.

Little experimental work has been done in the area of elastic-plastic dynamic fracture of metals. However, the problem has been simulated on model photoelastic materials. A. Kobayashi studied crack propagation in a tough polymer (Polycarbonate 80) using transmission photoelasticity [28]. He found that the crack speed range in the polymer was sufficiently low that a quasi-static analysis was sufficient, and an extensive plastic zone of the strip-yield-type was observed in his experiments. Dally and T. Kobayashi studied crack arrest at a bimaterial interface by bonding a brittle polymer to a tough polymer [29]. They found the adhesive toughness, analogous to the weld toughness in a metal, dominated the arrest event.

#### Research Needs Identified

It is apparent from reviewing the literature in this field that a considerable amount of useful research has been conducted that is relevant to the problem of crack arrest by high toughness strakes, but areas on which further work is needed have been identified:

1. Elastic-plastic effects in high-toughness arrester materials must be specifically addressed.
2. Some potentially useful theoretical work has already been done, including elastic-plastic effects in dynamic crack propagation, but insufficient experimental evidence is available to confirm the theory.



3. More research is needed on confirming fracture mechanics predictions of arrest behavior on specimens designed to simulate actual structural conditions. More large-scale experimental work of the type performed by Kihara et al. [9] is essential. Extensive instrumentation is necessary in order that dynamic and elastic-plastic effects can be properly accounted for in these tests.

The NBS research program is intended to address the identified needs.

### III. Literature Survey on Dynamic Instrumentation

Providing sufficient instrumentation to characterize the arrest event in ductile materials is a challenging problem. A literative survey has been conducted on experimental procedures that have been used in dynamic fracture, and on other experimental mechanics procedures that are potentially applicable. The discussion of experimental procedures is divided into two areas: what will be referred to as "conventional" procedures and optical techniques for characterizing full-field strain patterns.

#### Conventional Instrumentation

Conventional instrumentation includes trip wires or similar devices for measuring crack position and strain gages. This type of instrumentation is used routinely [11,20,30], and its application is relatively straightforward. The main difficulty is that all circuitry involved (e.g. strain gage bridges and amplifiers) must be sufficiently fast, and the data must be recorded at high speeds. This was accomplished in earlier studies [30] using storage oscilloscopes, but this requires manual data processing. More convenient, high-speed digital recording devices are now available.

Because energy exchange with the surroundings of a specimen is an important factor in the energy balance criterion (eq 1), it will also be

necessary to monitor load-point displacement under other than fixed-grip conditions. This can be done by using a variation of clip-on gages used for making displacement measurements.

### Optical Techniques

Various optical techniques exist that either have been applied or have the potential for application to dynamic fracture. These include holography laser speckle interferometry, photoelasticity, the method of caustic (shadow optics), and the moiré method. Of these, the moiré method or similar grid-type method seems to be the most suitable for this project. Holography is an extremely sensitive deformation measurement technique [31], which is ideally suited for measuring small elastic deformations. It is a relatively complicated and expensive method to apply and the high sensitivity is not essential for this project where the strains of interest are not extremely small. Speckle interferometry [32], which is also expensive, can be thought of as a special case of the moiré method, and the use of moiré method is more straightforward in this application.

The method of caustics [33] has proven quite useful for direct measurement of stress intensity factors in dynamic fracture experiments. Extension of the technique into the elastic-plastic fracture mechanics domain has not yet been accomplished, however. This technique is best suited for measuring deformation in the crack-tip region. In principle, it could be applied to full-field strain measurement, but it is sensitive to out-of-plane deformation, only and the patterns would be difficult to interpret.

Photoelastic analysis has been applied extensively to dynamic fracture mechanics [28, 29, 34, 35]. This method is most conveniently used in transmission with transparent model materials. This can yield useful information because by choosing suitable polymers, the model material can be made brittle or ductile [29]. To use photoelasticity for measurements directly on the

material of interest, photoelastic coatings must be employed [35]. Several drawbacks exist to the use of photoelastic coatings for dynamic applications. Coatings tend to be viscoelastic, thus the strain in the coating can lag behind the strain in the base material to which it is bonded, and the stress-optical coefficient varies with velocity. A more severe drawback for the application to crack propagation studies is the reinforcement effect of coatings. This is insignificant under normal circumstances but becomes important if the crack tends to run under the coating. This was overcome by Kobayashi and Dally [35] by employing a split coating and using side grooves to force the crack to run straight. However, it is desired to avoid the use of side grooves in this study so that the experimental configuration more closely simulates conditions in an actual structure.

Besides not having the disadvantages of the other optical techniques, the moiré method has the advantage that complete information about the in-plane strain fields may be obtained. A review of the application of the moiré method to fracture mechanics was presented by Liu and Ke [36]. In the moiré technique, a fine rectangular grid is applied to a specimen. When the specimen is deformed, light passing through the specimen grid and an undeformed reference ("Master") is reflected only where spaces between grid lines on the specimen grid coincide with transparent spaces on the Master grid, resulting in two fringe patterns. One pattern represents the horizontal displacement component,  $u$ , and the other the vertical displacement component,  $v$ . The mixed fringe pattern is difficult to interpret and, usually, must be separated. Or, a line reference grating may be used instead of a crossed grid, so that only one set of fringes is formed. Alternatively, instead of forming the fringe pattern directly, the deformed specimen grid itself may be photographed and the fringes formed optically at a later time [32].

In static testing, the moiré method has been used to measure crack opening displacement [37-41] and strains in the near-tip region of a crack [37, 38, 40-46]. Crack opening displacement, strain, and displacement in specimens with rapidly propagating cracks were made by Kobayashi et al [47-49]. In these experiments only the  $v$  fringes (corresponding to the displacement component normal to the crack) were recorded, and a single dynamic shot was taken. To capture the strain pattern corresponding to several crack positions the experiment was repeated thus relying on the reproducibility of the phenomenon.

### Moiré Method Implementation

There are several difficulties associated with applying the moiré method to transient dynamic problems, such as rapid crack propagation. These include high-speed data acquisition (i.e., high-speed photography), interpretation, and sensitivity.

Various techniques of high-speed photography have been tried, including a static camera with a microflash unit [47], a Q-switched laser light source [48], and an image-converter camera [49]. All of these techniques work well for capturing a single frame. The only technique that appears to have adequate dynamic spatial resolution when used to capture several frames is a Cranz-Schardin type camera [50]. The principle of a Cranz-Schardin camera is described in [51], and the application of this type of camera to high-speed photography of dynamic fracture experiments is discussed in [52] and [53].

As discussed above, two techniques may be used in applying the moiré method: the fringes may be photographed directly or the deformed grid may be photographed and the fringes formed later. Advantages and disadvantages are associated with either of these choices. Photographing the fringes directly places a less stringent spatial resolution demand on the camera but requires

more intense illumination. Separation of the  $u$  and  $v$  fringes is more difficult with this approach. If the camera has sufficient resolution to capture the image of the reference grid as well as the fringes, then it is possible to separate  $u$  and  $v$  by the spatial filtering method described by Chiang [54]. The resulting separated fringes are discontinuous, however, which would cause problems in attempting to digitize the data. Alternatives to separating the fringes are: 1) using a line grating to capture one set of fringes only, 2) assuming symmetry about a plane and capturing one set of fringes above this plane and one set below it, or 3) assuming reproducibility and repeating the experiment, capturing the  $u$  fringes in the first trial and the  $v$  in the second. Another disadvantage of photographing the fringes directly is that most of the optical enhancement techniques described below for improving strain sensitivity will not be applicable. This is offset by the advantage that the fringes produced by relatively high-frequency grids (which give higher strain sensitivity) can be captured photographically, whereas the grids themselves cannot.

If the deformed grid is photographed directly, then the fringes may be readily separated using spatial filtering. Alternatively, one set of fringes may be formed and then the other by changing the orientation of a line grating. This latter technique has the disadvantage that slight misalignment of the grating can introduce significant errors [55]. In addition, by placing the photograph of the deformed grid in an optical bench, such as the one shown in figure 3, various enhancement techniques can readily be applied. The disadvantage of photographing the deformed grid is that a coarser grid must be used than when fringes are photographed directly: deformed grids as fine as 4

lines per mm can be readily photographed, but finer grids than this may be difficult to capture [56].

A major drawback of the moiré method over other optical techniques is that it is relatively difficult to obtain adequate strain sensitivity. Sensitivity increases as finer grids are used. Specimen gratings as fine as 600 lines per mm have been successfully employed [57]. Such high frequency grids are relatively difficult to apply, and their use would rule out the option of photographing the deformed grid. The alternative is to use coarser grids in conjunction with various enhancement techniques. These techniques must be divided into those that can be applied when directly photographing the fringes and those that can only be applied when the deformed grid is photographed. In the former category are the use of mismatch [58] and the direct-fringe multiplication technique developed by Post [59]. Mismatch is an additive technique in which the effective strain level is boosted by adding fictitious strains through use of a reference grid of slightly different pitch than the specimen grid (linear mismatch), rotating the reference grid slightly with respect to the specimen grid (rotational mismatch), or both. Post's fringe multiplication technique involves use of a coarse specimen grid and a fine reference grid and illuminating at non-normal incidence. Higher diffraction orders form the image detected by the camera, resulting in a fringe density that is a multiple of that which would be produced by equal grids as coarse as the specimen grid. By this approach, fringe multiplication by a factor of 20 has been achieved with transparent specimens [60]. The technique is applicable in reflection but somewhat less straightforward [61]. When the deformed grid is photographed, optical techniques may be used for enhancement. Fringe multiplication may be accomplished through spatial filtering by only allowing selected higher diffracted orders to pass through the diffraction plane of an optical bench [54]. Fringe multiplication by a factor as high as

10 has been obtained using this approach by Chiang et al. [62]. Fringe shifting can also be achieved by optical means [61, 63], which permits interpolation in between fringes. A final enhancement technique may be used as a replacement for or in addition to the above methods. This utilizes the gray levels of light intensity between fringes to interpolate the displacement values [64, 65]. If a geometrical optics approximation is used to evaluate the light intensity of a moiré fringe pattern, displacement is predicted to be linearly related to intensity in between fringes [66]. A physical optics derivation by Sciamerella [64] for the case where only the zeroth and first diffraction orders are passed by the optical system predicts an arc-cosine relation between displacement and intensity. The latter derivation is perhaps a more accurate approximation for practical purposes and can be made exact by placing a suitable aperture in the optical system [64]. The human eye is not sufficiently sensitive to light intensity changes to apply this approach advantageously, so a photo-detection system is needed. This was accomplished by Ross, et al. [65] by using a scanning photo-densitometer. A video camera and video digitizer could also be used.

Digitizing of moiré fringe patterns permits digital processing and computation of strains, alleviating a drawback shared by all optical techniques, manual interpretation is tedious. Through digitization, a matrix of light intensity versus position is presented to the computer. The computer can locate fringes by finding light intensity extrema. Unambiguous automated numbering of the fringes by the computer is usually difficult. This can possibly be alleviated through the use of mismatch which can eliminate re-entrant fringe shapes and produce more predictable fringe patterns.

The results of the above survey indicate that the moiré method is the most suitable for application to this project. Experience by previous

researchers indicates that if the high-speed photography problem is overcome, the moiré technique will be relatively straightforward to apply to the measurement of plastic strains. Measurement of elastic strains will be more difficult and require application of some of the various enhancement techniques described above.

#### IV. NBS Research Plans

The objective of developing quantitative criteria for materials selection for crack arrester strakes must be met by first identifying the material parameter or parameters that govern arrest and then developing laboratory techniques for evaluating these parameters. A final step is to verify fracture mechanics predictions of crack arrest by using large-scale tests simulating actual structural conditions. The approach to meeting this objective will be to develop the required experimental and analytical capabilities for performing the above steps.

The extensive plastic deformation accompanying arrest in high-toughness strakes likely invalidates the use of LEFM parameters ( $K$  or  $G$ ). Other candidate parameters must first be identified and systematically tested. Candidate parameters include total plastic energy dissipation and dynamic generalizations of parameters that have proved useful in quasi-static elastic-plastic fracture mechanics (such as the  $J$  integral, the tearing modulus, crack opening displacement and crack opening angle).

The candidate crack arrest parameters will be evaluated using the "generation -phase, application phase" approach referred to by Kanninen [13]. This approach has proven highly successful both in testing the validity of dynamic LEFM [13], and in critically evaluating governing parameters for slow, stable crack growth and elastic-plastic deformation [67, 68]. In this approach



the value of a parameter is first determined for a given material on one specimen type. This is typically not a direct measurement; enough quantities must be measured to permit inference of the parameter using numerical computations. The usefulness of the parameter is then evaluated by using its value in numerical computations for predicting the fracture behavior of a different specimen configuration and comparing the experimental results for the second configuration with the analytical predictions.

A difficulty with this approach is that one has access only to the "endpoints" for performing the evaluation. If the prediction of the behavior of the second specimen is in poor agreement with the observed behavior, then, in principle, the candidate parameter is not useful. In practice, however, many other things could have gone wrong, such as problems with the measurement technique or inaccuracies in the numerical computations. This problem will be aggravated in the present work because measurement techniques for crack propagation are relatively difficult, and numerical modeling of elastic-plastic dynamic crack propagation requires development of new analysis capabilities. To overcome this difficulty, it is important to be able to provide "intermediate" information. For this purpose, extensive instrumentation will be used, including conventional instrumentation (strain gages and crack velocity gages) and moiré grids for measuring strain patterns over a large region. This will permit checking of the parameter-evaluating methodology at various stages. For example, confidence is provided if the numerical predictions of elastic-plastic deformation throughout a region in a specimen agree with experimental observations. Another important reason for the use of extensive instrumentation (in particular the use of moiré grids) is that it may permit direct experimental evaluation of certain parameters such as the J integral and plastic energy dissipation. This not only permits

checking of numerical calculations of the values of these parameters, but potentially could lead to a laboratory technique for evaluating critical parameter values directly.

A systematic framework has been described for developing materials selection criteria for crack arrester strakes. The NBS research plans will specifically address development of the necessary experimental and analytical capabilities for making use of this framework.

### Experimental Research

The eventual goal of providing the experimental capability for adequate characterization of dynamic crack propagation and arrest must be reached by carrying out the following steps concurrently: selection of a suitable specimen configuration, development of "conventional" dynamic instrumentation, performance of preliminary dynamic experiments, and development of moiré strain analysis capabilities.

### Specimen Design

The specimen design chosen for use in crack arrest experiments must be capable of arresting a crack under conditions simulating those in service. To date, study of the propagation behavior of a crack as it runs from a brittle material into a ductile material has been done using so-called "duplex" specimen geometries in which a brittle starter section that is welded to a ductile arrest section. This approach has the disadvantage that the weld material must be chosen carefully or it may dominate the test. The weld must be sufficiently brittle so that it does not arrest the crack but not too brittle or it will absorb the energy of the crack by shattering. The wedge-loaded double-cantilever beam specimen has been used in this application

[11]. This geometry has the drawback that arrest occurs under severe load drop conditions.

Tensile geometries, such as the hybrid double-tension test [9, 19], are commonly used in Japan. This design also arrests the crack under falling load conditions but to a lesser extent than in the DCB design, and more closely simulates service stresses in a vessel than does the DCB design. Disadvantages of this design include the need for a large capacity testing machine to be able to achieve large crack propagation lengths and the tendency for crack turning and branching [19], which obscures interpretation of results. Both of the above designs will be used in the current program with modifications to minimize the disadvantages. The first modification considered is to achieve a brittle starter section by locally heat-treating along a line in a ductile plate. This can be accomplished using an electron-beam weld. The second modification is the introduction of a spring in the load train to minimize load drop during propagation.

#### Conventional Dynamic Instrumentation

As discussed in the literature review, use of conventional instrumentation, such as strain gages and crack velocity gages, is relatively straightforward. The main difficulties are providing necessary circuitry with fast response and providing a high speed digital data recording capability so that computerized data reduction may be carried out at a later time. Devices meeting these needs are commercially available. Measurement of applied load is difficult in dynamic experiments, because the response of conventional load cells is too slow. This can be overcome by using remote strain gages to permit evaluation of remote stress and inference of the value of applied load. Conventional displacement transducers are too slow for recording remote displacement, but clip-on gages may be used for this purpose by using extension arms.

## Preliminary Dynamic Experiments

Preliminary dynamic experiments are needed to provide qualitative (and some quantitative) understanding of propagation and arrest under elastic-plastic conditions. This will be useful for later specimen design. In addition, information from these experiments will provide information needed in other areas. For example, as discussed below, a critical step in applying moiré strain analysis to dynamic experiments will be developing a high-speed photography capability. It is not readily apparent exactly what speeds are needed. Crack propagation rates in both brittle and ductile steels are known, but the situation is less clear in duplex specimens. The photoelasticity study of Dally and Kobayashi [28] suggests that very high-speed photography (submicrosecond exposure times) is required to capture the initial stages of crack propagation through the brittle part of the specimen, but that the crack speed (and accompanying deformation rates) decreases dramatically as the interface is approached. It is possible that the most interesting aspects of the experiment (e.g., evaluation of plastic deformation in the ductile portion of the specimen as the crack approaches the interface) occur relatively slowly, thus relaxing photography requirements somewhat.

## Moiré Analysis

Development of the moiré strain analysis capability is the most challenging part of the experimental work. The eventual goal is to be able to use high-speed photography to capture moiré fringes or the image of the deformed grid at several instants of time, then to apply whatever enhancement methods are needed to attain adequate strain sensitivity, and finally, to digitize the fringes and use a computer for data reduction. Three steps are required to reach this goal:

1. A static moiré capability must be developed. This entails the assembly of optical and digital equipment required for processing moiré data, and performing preliminary static experiments. The feasibility of applying this setup to dynamic experiments can then be evaluated in two ways: by using moiré results obtained under photographic conditions (e.g., illumination and aperture size) and simulating those that will be present in a dynamic experiment, and by using a single-shot dynamic experiment.

2. A multiframe high-speed photograph capability must be developed concurrently with the first step. As discussed in the literature review, the most feasible approach appears to be the use of a Cranz-Schardin multiple-spark-gap camera. Development of the necessary photographic technique for applying moiré to crack-arrest experiments will be carried out in a collaborative effort with Professor R. J. Sanford of the University of Maryland.

3. The moiré method must be applied in a dynamic experiment by photographing several frames and processing the data.

### Analytical Research

A cooperative program with C. F. Shih and L. B. Freund at Brown University is underway to develop the capability of finite-element modeling of dynamic elastic-plastic crack propagation and arrest. Finite-element modeling will be based upon modification of the dynamic elastic-plastic computer code ABAQUS [69]. The development will be carried out in three phases. The first, a preliminary phase, involves installation of the program, modification of the code to permit dynamic crack propagation modeling, computation of relevant parameters, such as the J integral; and preliminary verification. In the second phase, dynamic elastic-plastic analysis of crack propagation and arrest in homogeneous materials will be undertaken.

Preliminary screening will be done on candidate parameters governing ductile crack propagation, and comparison will be made with experimental results available in the literature. In the final phase, modeling of duplex specimens of the type used in the experimental part of this program will be done and comparison made with experimental results.

---

This report was prepared as part of the Fracture Control Technology Program under the sponsorship of Dr. H. H. Vanderveldt, Naval Sea Systems Command (SEA 05R15). The effort was directed by Mr. John P. Gudas, David Taylor Naval Ship R&D Center, under Program Element 62761N, Task Area Sf-61-544-504.

## References

- [1] Pellini, W. S., Principles of Structural Integrity Technology, Office of Naval Research, Arlington, Virginia, 1976
- [2] Pellini, W. S. and Puzak, P. O., "Fracture Analysis Diagram Procedures for the Fracture Safe Engineering Design of Steel Structures," Bulletin No. 88, Welding Research Council, New York, 1963.
- [3] Hahn, G. T., Rosenfield, A. R., Marshall, C. W., Hoagland, R. G., Gehler, P. C., and Kanninen, M. F., "Crack Arrest Concepts and Applications," in Fracture Mechanics, eds. N. Perrone et al., University of Virginia Press, Charlottesville, 1978, pp. 205-227.
- [4] Kanninen, M., Mills, E., Hahn, G., Marshall, C. Broek, D., Coyle, A., Masubush, K., and Itoga, K., "A Study of Ship Hull Crack Arrester Systems," Ship Structure Committee Report No. SSC-265, Washington, D.C., 1977.
- [5] Krafft, J. M. and Irwin, G. P., "Crack Velocity Considerations," Fracture Toughness Testing and Its Applications, STP 381, ASTM, Philadelphia, 1965, pp. 114-129.
- [6] Freund, L. B., "Dynamic Crack Propagation," The Mechanics of Fracture, ed. F. Erdogan, ASME AMD, V. 19, ASME, New York, 1975, pp. 105-134.
- [7] Crosley, P. B. and Ripling E. P., "Comparison of Crack Arrest Methodologies," Crack Arrest Methodology and Applications, STP 711, ASTM, Philadelphia, 1980, pp. 211-220.
- [8] Crosley, P. B. and Ripling, E. J., Crack Arrest Studies, Report No. NP-1225, Electric Power Research Institute, Palo Alto, California, 1979.
- [9] Kihara, H., Kanazawa, T., Ikeda, K., Okage, H., Nakijima, T., and Lajima, A., Study on Welded Type Crack Arrester, IIW Doc. No. X-618-71, 1971.
- [10] Freund, L. B., "Crack Propagation in an Elastic Solid Subjected to General Loading. III. Stress Wave Loading," J. Mech. Phys. Solids, Vol. 21, 1973, pp. 47-61.
- [11] Hahn, G. T., Hoagland, R. G., and Rosenfield, A. R., "Fast Fracture Resistance and Crack Arrest in Structural Steels," Ship Structures Committee Report No. SSC-242, Washington D.C., 1973.
- [12] Kanninen, M., "A Dynamic Analysis of Unstable Crack Propagation and Arrest in the DCB Test Specimen," Int. J. Fract., V. 10, 1973, pp. 415-430.
- [13] Kanninen, M., "Whither Dynamic Fracture Mechanics?," Numerical Methods in Fracture Mechanics, eds. A. Luxmoore and R. Owen, University of Swansea Press, Swansea, United Kingdom, 1980, pp. 433-456.

- [14] Dahlberg, L., Nilson, F., and Brickstad, B., "Influence of Specimen Geometry on Crack Propagation and Arrest Toughness," Crack Arrest Methodology and Applications, STP 711, ASTM, Philadelphia, 1980, pp. 89-108.
- [15] Dahlberg, L., "Plastic Effects in Dynamic Crack Propagation," Advances in Fracture Research, Proceedings of the Fifth International Conference on Fracture, Pergamon, Oxford, 1981, pp. 2195-2203.
- [16] Feely, F. J., Jr., Northrup, M. S., Kleppe, S. R., and Geisamer, M., "Studies on the Brittle Fracture of Tankage Steel Plates," Weld. J. Res. Suppl., V. 34, 1955, pp. 596s-607s.
- [17] Kanazawa, T., "Recent Studies on Brittle Crack Propagation in Japan," Dynamic Crack Propagation, ed. G. Sih, Noordhoff, Leyden, The Netherlands, 1973, pp. 565-597.
- [18] Koshiga, F., Imazawa, O., and Takehano, S., "Arrest-Transition of Brittle Crack in Steel Plate," J. Soc. Nav. Archit. Japan, V.114, 1963, pp. 200-209.
- [19] Kihora, H., Kanazawa, T., Ikeda, K., Maenaka, H., Kinoshita, M., Nagomoto, R., and Yajima, H., "Effectiveness of Crack Arrester," J. Soc. Nav. Archit. Japan, V. 122, 1967, pp. 191-199.
- [20] Kanazawa, T., Machida, S., Teramoto, T., and Yoshinari, H., "Study on Fast Fracture and Crack Arrest," Exp. Mech., V. 21, 1981, pp. 78-88.
- [21] Dugdale, D., "Yielding of Steel Sheets Containing Slits," J. Mech. Phys. Solids, V. 8, 1960, pp. 100-104.
- [22] Goodier, J. and Field, F., "Plastic Energy Dissipation in Crack Propagation," Fracture of Solids, eds. D. C. Drucker and J. Gilman, Gordon and Breach, New York, 1963, pp. 103-118.
- [23] Kanninen, M., "An Estimate of the Limiting Speed of a Propagating Ductile Crack", J. Mech. Phys. Solids, V. 16, 1968, pp. 215-228.
- [24] Hoagland, R., Rosenfield, A., and Hahn, G., "Mechanisms of Fast Fracture and Arrest in Steels," Met. Trans., V. 3, 1972, pp. 123-136.
- [25] Ogura, N. "A Study on the Ductile Arrest of Brittle Crack," J. Soc. Nav. Archit. Japan, V. 110, 1961, pp. 443-453.
- [26] Achenbach, J., and Kanninen, M., "Crack Tip Plasticity in Dynamic Fracture Mechanics," Fracture Mechanics, ed. N. Perrone, University of Virginia Press, Charlottesville, 1978, pp. 649-670.
- [27] Freund, L. B. and Douglas, A., "Dynamic Crack Growth in an Elastic-Plastic Material," presented at 2nd International Symposium on Elastic-Plastic Fracture Mechanics, ASTM, Philadelphia, October 1981.
- [28] Kobayashi, A. S. and Lee, O., "Elastic Field Surrounding a Propagating Ductile Crack," presented at the 2nd International Symposium on Elastic-Plastic Fracture, ASTM, Philadelphia, October 1981.



- [29] Dally, J. and Kobayashi, T., "Crack Arrest in Duplex Specimens," Int. J. Solids Struct., V. 14, 1978, pp. 121-129.
- [30] Akita, Y. and Ikeda, K., "Experimental Research on the Propagation of Brittle Fracture," Report No. 40, Transportation Technical Research Institute, Tokyo, Japan, November 1959.
- [31] Post, D., "Optical Interference for Deformation Measurements - Classical, Holographic, and Moire Interferometry", Mechanics of Nondestructive Testing, ed. W. Stinchcomb, Plenum Publishing Corp. New York, 1980.
- [32] Chiang, F. P. "Optical Stress Analysis Using Moire Fringe and Laser Speckles," Opt. Eng., V. 18, No. 5, 1979, pp. 448-455.
- [33] Katthoff, J. F., Beinart, J., and Winkler, S., "Measurements of Dynamic Stress Intensity Factors for Fast Running and Arresting Cracks in Double-Cantilever-Beam Specimens," Fast Fracture and Crack Arrest, eds. G. T. Hahn and M. F. Kanninen, STP 627, 1977, ASTM, Philadelphia, pp. 161-176.
- [34] Kobayashi, A., "Photoelasticity Techniques," Experimental Techniques in Fracture Mechanics, ed. A. S. Kobayashi, Society For Experimental Stress Analysis, Westport, Connecticut, 1973, pp. 126-145.
- [35] Kobayashi, T. and Dally, J. "Dynamic Photoelastic Determination of the  $\dot{\gamma}$ -K Relation for 4340 steel," Crack Arrest Methodology and Applications, STP 711, G. T. Hahn and M. F. Kanninen, Eds., ASTM, Philadelphia, 1980, pp. 189-210.
- [36] Liu, H. W. and Ke, J. S., "Moire Method," Experimental Techniques in Fracture Mechanics, V. II, ed. A. S. Kobayashi, Society For Experimental Stress Analysis, Westport, Connecticut, 1973, pp.111-165.
- [37] Luxmoore, A. and Wyatt, P. J., "Application of the Moire Technique to Fracture Toughness Tests on Zirconium Alloys," J. Strain Anal., V. 5, 1970.
- [38] Kobayashi, A. S., Engstrom, W. L., and Simon. B. R., "Crack Opening Displacements and Normal Strains in Centrally Notched Plates," Exp. Mech., V. 9, 1969, pp. 163-170.
- [39] Schaeffer's, Ke, J. S., and Liu, H-W., "Deformation and the Strip Necking Zone in a Cracked Steel Sheet," Exp. Mech., V. 11, 1971, pp. 172-175.
- [40] Ke, J. S., "Crack Tip Deformation and Ductile Fracture Criteria," PhD Dissertation, Syracuse University, Syracuse, New York, 1973.
- [41] Gavigan, W. J., Liu, H. W., and Ke, J. S., "Local and Gross Deformation in Cracked Metallic Plates and an Engineering Ductile Fracture Analysis," paper 71-PUP-52, ASME, New York, 1971.
- [42] Liu, H. W., Gavigan, W. J., and Ke, J. S., "An Engineering Analysis of Ductile Fracture," Int. J. Fract., V. 6, 1970, pp. 255-264.
- [43] Underwood, J. H. and Kendall, D. P., "Measurement of Microscopic Plastic Strain Distributions in the Region of a Crack Tip," Exp. Mech., V. 9., 1969, pp. 296-384.

- [44] Underwood, J. H., Swedlow, J. L., and Kendall, D. P., "Experimental and Analytical Strain in an Edge Cracked Sheet," Eng. Fract. Mech., V. 2, 1971, pp. 183-196.
- [45] Ke, J. W. and Liu, H. W., "The Measurements of Fracture Toughness of Ductile Materials," Eng. Fract. Mech., V. 5, 1973, pp. 187-202.
- [46] Luxmoore, A. R., Gordner, N. A., and Wyatt, P. J., "A Comparison of Finite Element and Experimental Studies on the Deformation of Zirconium Notched Bend Specimens," J. Mech. Phys. Solids, V. 9, 1971, pp. 395-406.
- [47] Kobayashi, A. S., Harms, D. G., and Engstrom, W. L., "Transient Analysis in a Fracturing Epoxy Plate," Proc. 1st Intl. Conf. on Fract., V. 3., Sendai, Japan, 1965, Japanese Society for Strength and Fracture of Materials, Tokyo, p. 1809.
- [48] Kobayashi, A. S., Harris, D. G., and Engstrom, W. L., "Transient Analysis in a Fracturing Magnesium Plate," Exp. Mech., V. 7, 1967, pp. 434-440.
- [49] Kobayashi, A. S. and Engstrom, W. L., "Transient Analysis in Fracturing Aluminum Plate," Rept No TR3A, University of Washington, Dept. of Mechanical Engineering, Seattle, 1967.
- [50] R. J. Sanford, private communication.
- [51] Riley, W. F. and Dally, J. W., Exp. Mech. V. 9, 1969, pp. 27-33N.
- [52] Kobayashi, T. and Dally, J. W., "Relation Between Crack Velocity and the Stress Intensity Factor in Birefringent Polymers," Fast Fracture and Crack Arrest, eds. G. T. Hahn and M. F. Kanninen, STP 627, 1977, ASTM, Philadelphia, pp. 257-273.
- [53] Holloway, D. L., Kobayashi, T., and Barker, D. B., "High Speed Photography of Dynamic Crack Propagation in Rock," Optical Methods In Mechanics of Solids, ed. A. Lagarde, Sijthoff and Noordhoff, Leyden, The Netherlands, 1981, pp. 473-486.
- [54] Chiang, F. P., "Techniques of Optical Spatial Filtering Applied to the Processing of Moiré Fringe Patterns," Exp. Mech. V. 6, 1969, 523-526.
- [55] Post, D., "The Moiré Grid Analyzer Method for Strain Analysis," Experimental Mechanics, V. 5, 1968, pp. 368-377.
- [56] Parks, V. J., private communication.
- [57] Bowles, D. E., Post, D., Herakovich, C. T., and Tenney, D. R., "Moiré Interferometry for Thermal Expansion of Composites," Exp. Mech. V. 21, 1981, pp. 441-448.
- [58] Chiang, F. P., "A Method to Increase the Accuracy of Moiré Method," Proc. ASCE Journal of the Eng. Mech. Div., V. 91, 1965, pp. 137-149.
- [59] Post, D., "Moiré Fringe Multiplication with a Nonsymmetrical Doubly Biased Reference Grating," Appl. Opt., V. 10, 1971, pp. 901-907.

- [60] Post, D. and MacLaughlin, T. F., "Strain Analysis by Moiré Fringe Multiplication," Exp. Mech., V. 11, 1971, pp. 408-413.
- [61] Sciamerella, C. A. and Lurowist, N., "Multiplication and Interpolation of Moiré Fringe Order by Purely Optical Techniques," J. Appl. Mech., V. 32, 1967, pp. 425-430.
- [62] Chiang, F. P., Parker, B., Oplinger, D., and Slepetz, J., "Multipurpose Optical Moiré Processor," Opt. Eng., V. 18, 1979, pp. 456-460.
- [63] Chiang, R. P., Parks, V. J., and Durelli, A. J., "Moiré Fringe Interpolation and Multiplication by Fringe Shifting," Exp. Mech., V. 8, 1968, pp. 554-560.
- [64] Sciamerella, C. A., "Basic Optical Law in the Interpretation of Moiré Patterns Applied to the Analysis of Strains - Part 1," Exp. Mech., V. 5, 1965, pp. 154-160.
- [65] Ross, B. E., Sciamerella, C. A., and Sturgess, D., "Basic Optical Law in the Interpretation of Moiré Patterns Applied to the Analysis of Strains, Part 2," Exp. Mech., V. 5, 1965, pp. 161-166.
- [66] Durelli, A. J. and Parks, V. J. Moiré Analysis of Strain, Prentice-Hall, Englewood Cliffs, New Jersey, 1970.
- [67] Shih, C. F., Andrews, W. R., deLorenzi, H. G., German, M. D., VanStone, R. N., and Mowbray, D. F. "Methodology For Plastic Fracture," EPRI Ductile Fracture Research Review Document NP-80-10-LD, Electric Power Research Institute, Palo Alto, California, 1980.
- [68] Kanninen, M. F., Abou-Sayed, I. S., Marschall, C. W., and Broeck, D., "Development of a Plastic Fracture Methodology," EPRI Ductile Fracture Research Review Document, EPRI NP-80-10-LD, Electric Power Research Institute, Palo Alto, California, 1980.
- [69] ABAQUS, Hibbit & Karlsson, Inc., Providence, Rhode Island.

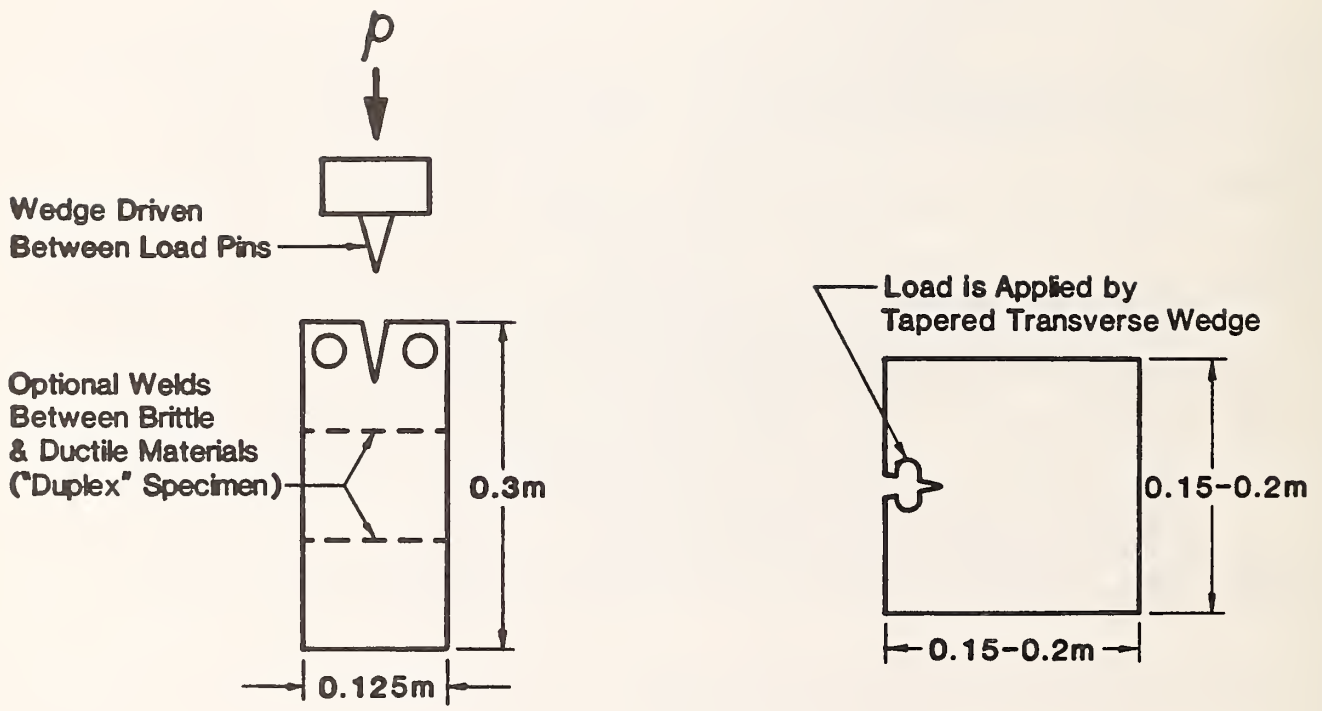

Figure 1. Typical Small Scale Crack Arrest Specimens.

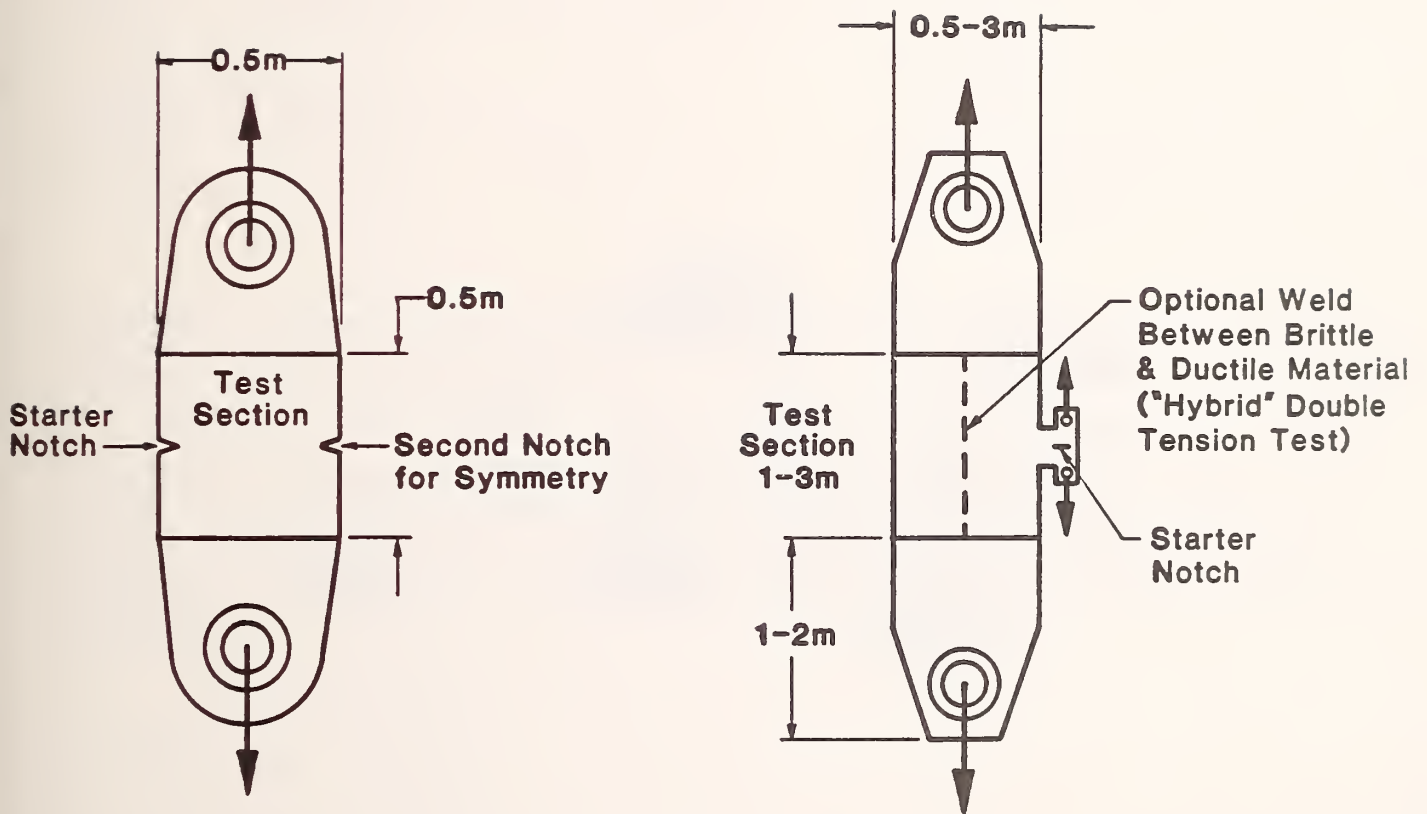

Fig. 2. Large Scale Crack Arrest Specimens.

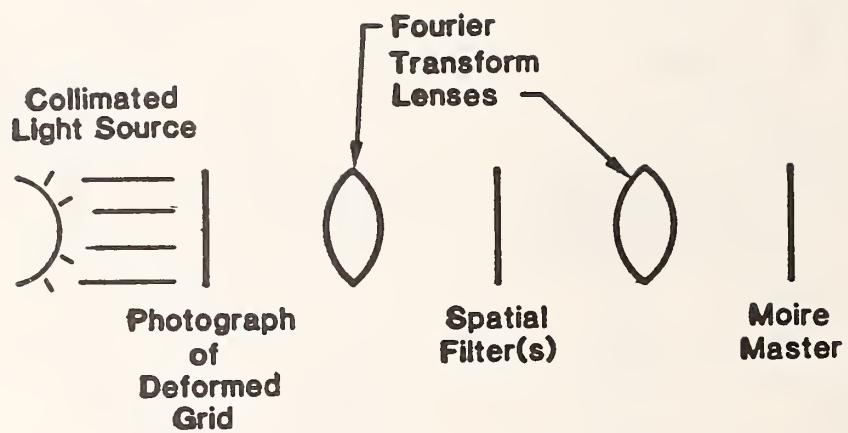

Figure 3. Optical Bench For Moiré Enhancement.

U.S. DEPT. OF COMM. <b>BIBLIOGRAPHIC DATA SHEET</b> <i>(See instructions)</i>	<b>1. PUBLICATION OR REPORT NO.</b> NBSIR 83-1681	<b>2. Performing Organ. Report No.</b>	<b>3. Publication Date</b> January 1983
<b>4. TITLE AND SUBTITLE</b> Interim Progress Report: Materials Selection Criteria for Crack Arrester Strakes in Naval Vessels			
<b>5. AUTHOR(S)</b> R. B. King			
<b>6. PERFORMING ORGANIZATION</b> <i>(If joint or other than NBS, see instructions)</i>  NATIONAL BUREAU OF STANDARDS DEPARTMENT OF COMMERCE WASHINGTON, D.C. 20234		<b>7. Contract/Grant No.</b>	<b>8. Type of Report &amp; Period Covered</b>
<b>9. SPONSORING ORGANIZATION NAME AND COMPLETE ADDRESS</b> <i>(Street, City, State, ZIP)</i>  U.S. Navy David Taylor Naval Ship R&D Center Annapolis, MD 21402			
<b>10. SUPPLEMENTARY NOTES</b>  <input type="checkbox"/> Document describes a computer program; SF-185, FIPS Software Summary, is attached.			
<b>11. ABSTRACT</b> <i>(A 200-word or less factual summary of most significant information. If document includes a significant bibliography or literature survey, mention it here)</i>  Research has been conducted on the problem of developing quantitative criteria for materials selection for crack arrester strakes in naval vessels. Quantitative analysis of material performance in service requires application of dynamic elastic-plastic fracture mechanics. Results of an extensive literature survey in the area of dynamic fracture mechanics with specific attention given to the crack arrest application are presented. The research program that has been developed is described in detail.			
<b>12. KEY WORDS</b> <i>(Six to twelve entries; alphabetical order; capitalize only proper names; and separate key words by semicolons)</i>  crack arrest; crack propagation; dynamic fracture mechanics; elastic-plastic fracture mechanics; materials selection; toughness.			
<b>13. AVAILABILITY</b>  <input checked="" type="checkbox"/> Unlimited <input type="checkbox"/> For Official Distribution. Do Not Release to NTIS <input type="checkbox"/> Order From Superintendent of Documents, U.S. Government Printing Office, Washington, D.C. 20402.  <input checked="" type="checkbox"/> Order From National Technical Information Service (NTIS), Springfield, VA. 22161		<b>14. NO. OF PRINTED PAGES</b>  36  <b>15. Price</b>  \$8.50	











