



A11106 979011

NBS  
PUBLICATIONS

NBSIR 83-1685

# **GAS ORIFICE METER DISCHARGE COEFFICIENTS AS DETERMINED BY MASS FLOW MEASUREMENTS**

---

D.B. Mann  
J.A. Brennan  
C.F. Sindt  
J.F. LaBrecque  
S.E. McManus  
C.H. Kneebone

National Bureau of Standards  
U.S. Department of Commerce  
Boulder, Colorado 80303

August 1983

QC  
100  
.U56  
83-1685  
1983  
c. 2



NBSIR 83-1685

2000  
1483  
No. 83-1685  
C. 2

# **GAS ORIFICE METER DISCHARGE COEFFICIENTS AS DETERMINED BY MASS FLOW MEASUREMENTS**

---

D.B. Mann  
J.A. Brennan  
C.F. Sindt  
J.F. LaBrecque  
S.E. McManus  
C.H. Kneebone

Chemical Engineering Science Division  
National Engineering Laboratory  
National Bureau of Standards  
U.S. Department of Commerce  
Boulder, Colorado 80303

August 1983

Sponsored by:  
Gas Research Institute  
8600 West Bryn Mawr Avenue  
Chicago, Illinois 60631



---

U.S. DEPARTMENT OF COMMERCE, Malcolm Baldrige, Secretary .

NATIONAL BUREAU OF STANDARDS, Ernest Ambler, Director



# CONTENTS

	Page
1. INTRODUCTION .....	1
2. REFERENCE FLOW SYSTEM .....	2
2.1 Components.....	2
2.2 Instrumentation.....	4
2.2.1 Instruments for Measurement of Mass Flow. ....	4
2.2.2 Instrumentation on the Gas Portion of the System.....	4
2.3 Automatic Data Acquisition.....	5
2.4 Operation.....	6
3. ORIFICE METER GAS FLOW TESTS.....	7
3.1 Orifice Flowmeter Test Equipment.....	8
3.1.1 Orifice Meter Runs.....	8
3.1.2 Orifice Plates.....	8
3.1.3 Flow Conditioners.....	10
3.1.4 Gas System Piping.....	10
3.2 Orifice Meter Instrumentation.....	13
3.3 Flow Test Procedures.....	15
3.4 Test Results.....	17
3.5 Future Plans.....	17
REFERENCES CITED.....	94
APPENDIX I. Measurements of Orifice Meter Runs. ....	95
APPENDIX II. Measurements of Orifice Plates .....	104
APPENDIX III. Measurements of Flow Conditioners.....	121

## LIST OF TABLES

	Page
Table 1. Orifice Plate-Meter Run Test Combinations	15
Table 2(a) Test Meter Identification and Physical Measurements Nominal 2 Inch AGA/API Orifice Meter (SI Units)	36
Table 2(b) Test Number, Measured and Calculated Quantities Nominal 2 Inch AGA/API Orifice Meter (SI Units)	37
Table 3(a) Test Meter Identification and Physical Measurements Nominal 3 Inch AGA/API Orifice Meter (SI Units)	42
Table 3(b) Test Number, Measured and Calculated Quantities Nominal 3 Inch AGA/API Orifice Meter (SI Units)	43
Table 4(a) Test Meter Identification and Physical Measurements Nominal 4 Inch AGA/API Orifice Meter (SI Units)	49
Table 4(b) Test Number, Measured and Calculated Quantities Nominal 4 Inch AGA/API Orifice Meter (SI Units)	50
Table 5(a) Test Meter Identification and Physical Measurements Nominal 6 Inch AGA/API Orifice Meter (SI Units)	59
Table 5(b) Test Number, Measured and Calculated Quantities Nominal 6 Inch AGA/API Orifice Meter (SI Units)	60
Table 6(a) Test Meter Identification and Physical Measurements Nominal 2 Inch AGA/API Orifice Meter (British Units)	65
Table 6(b) Test Number, Measured and Calculated Quantities Nominal 2 Inch AGA/API Orifice Meter (British Units)	66
Table 7(a) Test Meter Identification and Physical Measurements Nominal 3 Inch AGA/API Orifice Meter (British Units)	71
Table 7(b) Test Number, Measured and Calculated Quantities Nominal 3 Inch AGA/API Orifice Meter (British Units)	72

Table 8(a) Test Meter Identification and Physical Measurements Nominal 4 Inch AGA/API Orifice Meter (British Units)	78
Table 8(b) Test Number, Measured and Calculated Quantities Nominal 4 Inch AGA/API Orifice Meter (British Units)	79
Table 9(a) Test Meter Identification and Physical Measurements Nominal 6 Inch AGA/API Orifice Meter (British Units)	88
Table 9(b) Test Number, Measured and Calculated Quantities Nominal 6 Inch AGA/API Orifice Meter (British Units)	89

LIST OF FIGURES:

	Page
Figure 1 Flow reference facility schematic	3
Figure 2 Typical orifice meter flange	9
Figure 3 Flow conditioner	11
Figure 4 Gas system piping schematic	12
Figure 5(a) Results from 2 inch meter with the 1-1/8 inch orifice plate	13
Figure 5(b) Results from 2 inch meter with the 1-3/8 inch orifice plate	19
Figure 5(c) Results from 2 inch meter with the 1-1/2 inch orifice plate	20
Figure 6(a) Results from 3 inch meter with the 1-1/8 inch orifice plate	21
Figure 6(b) Results from 3 inch meter with the 1-1/2 inch orifice plate	22
Figure 6(c) Results from 3 inch meter with the 1-3/4 inch orifice plate	23
Figure 6(d) Results from 3 inch meter with the 2 inch orifice plate	24
Figure 6(e) Results from 3 inch meter with the 2-1/4 inch orifice plate	25
Figure 7(a) Results from 4 inch meter with the 1-1/2 inch orifice plate	26
Figure 7(b) Results from 4 inch meter with the 2 inch orifice plate	27
Figure 7(c) Results from 4 inch meter with the 2-1/4 orifice plate	28
Figure 7(d) Results from 4 inch meter with the 2-5/8 inch orifice plate	29
Figure 7(e) Results from 4 inch meter with the 3 inch orifice plate	30
Figure 8(a) Results from 6 inch meter with the 1-1/4 inch orifice plate	31
Figure 8(b) Results from 6 inch meter with the 2-1/4 inch orifice plate	32
Figure 8(c) Results from 6 inch meter with the 3 inch orifice plate	33
Figure 8(d) Results from 6 inch meter with the 3-1/2 inch orifice plate	34
Figure 9 Plot showing Reynolds number ranges for original Ohio State water data [13] and data from this work	35



## UNITS AND DIMENSIONS

### International System (SI) and U.S. Customary (British)

#### Unit Names and Symbols

Quantity	SI Unit Name	SI Unit Symbol	British Unit Name	British Unit Symbol
length	meter	m	foot	ft
mass	kilogram	kg	pound	lb
time	second	s	second	s
temperature	kelvin	K	fahrenheit	°F

#### Conversion Factors for Tabular Listings

to convert	to	multiply by
ft	m	0.30480
°F	K	$T_K = (t_{°F} + 459.67)/1.8$
psia	MPa	6.8948 (10 <sup>-3</sup> )
in H <sub>2</sub> O (60°F)	kPa	0.248843
lb <sub>m</sub> /ft <sup>3</sup>	kg/m <sup>3</sup>	16.01846

**Note:** In addition to the tabular listings, we occasionally use U.S. Customary Units (non-SI) within the text to accommodate the intended audience.



GAS ORIFICE METER DISCHARGE COEFFICIENTS AS DETERMINED BY  
MASS FLOW MEASUREMENTS

D. B. Mann, J. A. Brennan, C. F. Sindt,  
J. F. LaBrecque, S. E. McManus and C. H. Kneebone  
National Bureau of Standards  
Boulder, CO 80303

Performance data of gas orifice meter runs and plates have been generated under a U.S. gas industry supported program. The data have been developed using nitrogen gas and a unique NBS gas flow measurement facility capable of directly measuring the mass of gas metered by the orifice device. Direct comparison of predictions from empirical equations can now be made at orifice bore Reynolds Numbers near four million. Two meter runs for each of four nominal line sizes and two sets of orifice plates with up to six beta ratios per set were interchanged in order to develop full meter performance characteristics. Orifice meter and flow reference system data are used to calculate discharge and expansion coefficients which in turn are compared to those derived from existing equations. Orifice meter performance data and system descriptions are provided.

Key words: discharge coefficients; flow measurement; flowmeter; gas flow; mass flow; orifice meter.

## 1. INTRODUCTION

Staff members of the National Bureau of Standards (NBS) laboratories located at Boulder, Colorado have modified an existing cryogenic liquid flowmetering facility to allow precise flow measurement of gas at ambient temperatures. The gas meter measurement is compared directly to the existing liquid mass flow reference system which is based on mass and time measurements [1]. An extensive gas flowmetering research program based on this new facility is in progress. The program was initially supported by the American Gas Association (AGA) and the Gas Research Institute (GRI) and is currently funded entirely by the Gas Research Institute (Contract 5080-353-0422). The cryogenic liquid measurement part of the program continues under sponsorship of the Compressed Gas Association (CGA).

The concept of extending the cryogenic flow reference system to gas flow operation was proposed by Mann and Brennan [2] in 1977. Funding to modify the existing facility to demonstrate the feasibility of gas flow operation was made available from NBS and modifications were completed in July of 1979. The gas flowmetering research program is directed through the GRI-NBS Basic Gas Metering Steering Committee which plans program objectives, reviews current progress and aids NBS in the selection of experiments directed at solutions to current gas metering problems.

The research area of immediate interest to the Committee was the performance of the gas orifice meter. A gas turbine meter was included in the program and was used as a facility monitor for setting flow rates. Future research is planned on the performance of gas turbine flowmeters and the devices.

The Committee provided two sets of orifice meter runs in four nominal line sizes with orifice plates which provided six beta ratios ranging from 0.2 to

0.75 for each run size. Three flow conditioners were also provided by the Committee. The orifice meter runs, plates, and flow conditioners were fabricated to natural gas industry (U.S.) standards and are the joint property of the American Gas Association and the American Petroleum Institute (AGA/API). Using these multiple sets of runs and plates, a more representative range of meter performance was possible compared to that of a single run size and one or two special orifice plates. A description of the flow reference system, the orifice meters under test and the test procedures are given here in detail. Data are presented in both tabular and graphical form. Archival data are also available [3] and a summary report of this program appears in the literature [4].

Data presented provide added confirmation that suspected gas orifice metering performance anomalies exist in the flow range covered. The data do not necessarily reveal sources of these anomalies at this time and research is continuing in order to establish a rational basis for what needs to be done to significantly improve or replace present correlations.

## 2. REFERENCE FLOW SYSTEM

### 2.1 Components

The flow reference system is shown schematically in figure 1 and consists of a closed loop thermodynamic cycle where the process fluid, nitrogen, is circulated between temperature limits of 85 K and 300 K at pressures of 0.5 MPa to 4.1 MPa. Work is done on the cycle by centrifugal pumps operating at 85 K which increase the liquid nitrogen pressure from 0.5 MPa to 4.1 MPa. Heat energy enters the process from the ambient surroundings and through a steam heat exchanger which controls the gas temperature at the test section. Heat energy is removed from the system by the refrigeration effect provided by boiling liquid nitrogen in the subcooler, supplementary liquid nitrogen introduced at the main heat exchanger and water cooling at the water heat exchanger following the gas test section.

The low pressure cryogenic portion of the cycle is maintained at a pressure of 0.5 MPa by introducing helium gas at the catch and weigh tank. This inert pressurant provides necessary over-pressure to inhibit boiling of the liquid nitrogen throughout the cryogenic portion of the cycle. The high pressure portion of the cycle is accomplished in two steps. The variable speed centrifugal boost pump provides a controlled pressure of about 0.7 MPa at the inlet to a fixed speed pressure pump. The centrifugal pressure pump then increases the pressure of the process fluid to 4.1 MPa. Process fluid flow is controlled by operation of the expansion valve. The pressure level of 4.1 MPa was selected because the critical pressure of nitrogen is 3.4 MPa and operation above this pressure avoids two phase boiling and condensing in the main heat exchanger; a possible source of flow noise.

The main heat exchanger is a five pass, plate-fin type constructed of aluminum and insulated with a 30 cm thickness of polyurethane foam. The cross section of the heat exchanger is 63.5 cm by 33 cm and is 4.92 meters in overall length including manifolds. Two of the five passes provide counter current heating and cooling of the process fluid. Two additional passes contain liquid nitrogen supplemental refrigeration. The final pass is blocked at both ends and is used as a gas thermometer for indication and control of heat exchanger pressures and temperatures during the test draft period.

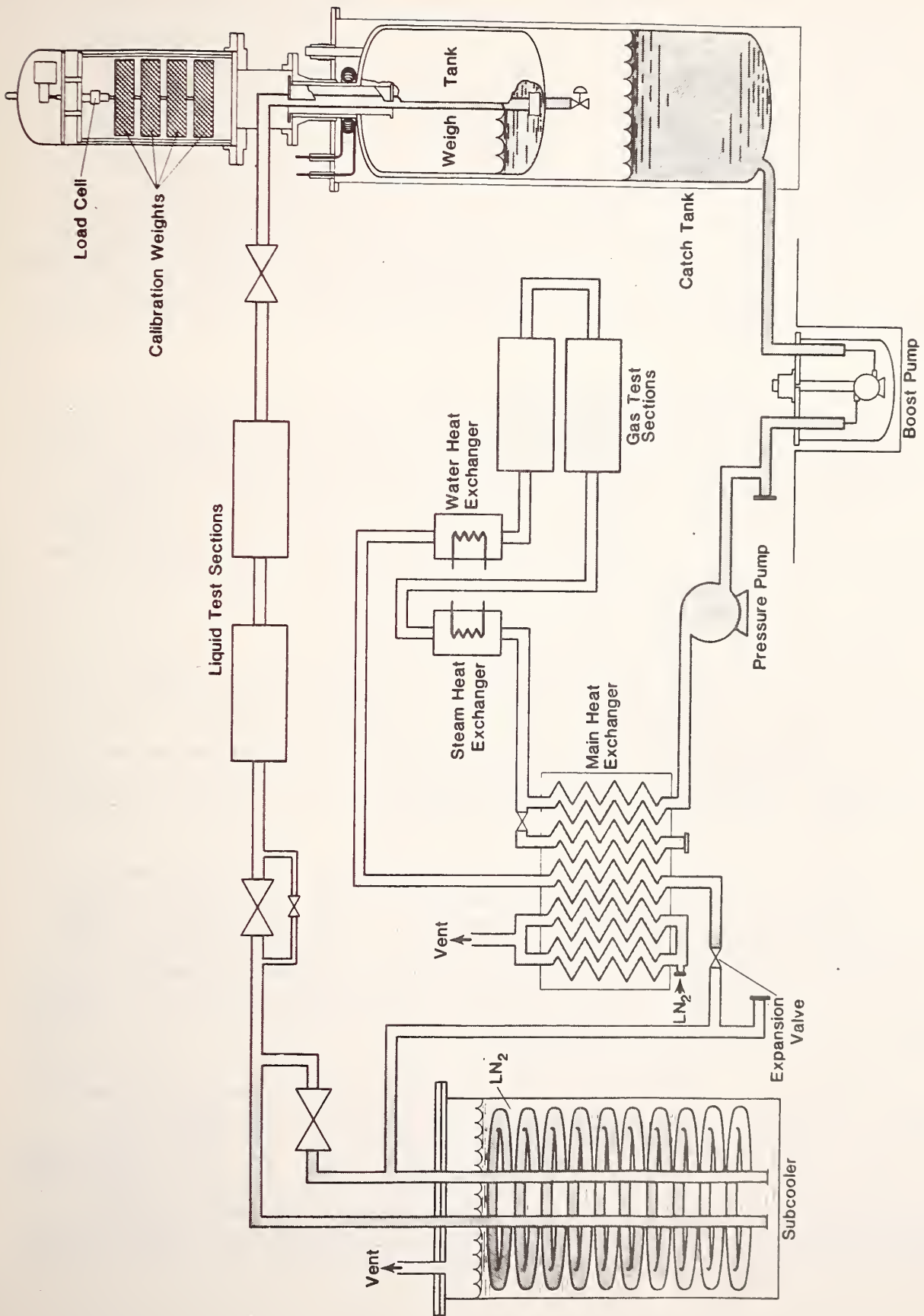

Figure 1. Flow reference facility schematic.

## 2.2 Instrumentation

All of the instruments on the Gas Mass Flow Reference System were electrical devices except several pressure gauges that were used to monitor the system during start up. The electrical instrumentation was read by two small computers which were dedicated to the system and were on line during the system operation. One computer accessed instruments in the low pressure, cryogenic liquid portion of the system (computer A). The other computer was used primarily but not exclusively to control and access instruments on the high pressure, gas portion of the system (computer B). Both computers operated in real time and interrogated the instruments at specified intervals or events. The signals read by the computers were converted to engineering units and were displayed at the computer terminals and/or stored on a mass storage device such as a magnetic tape or disk.

### 2.2.1 Instruments for Measurement of Mass Flow

Instrumentation input to computer A included the liquid nitrogen temperatures and pressures, voltage from the load cell in the catch tank, the excitation voltage to the load cell and the test draft time. The load cell voltage and the excitation voltage to the load cell were read with digital voltmeters. The pressure and temperature sensors were read with a data logger. The data logger and the digital voltmeters were read by computer A, which then calculated the mass flow rate and recorded these data on magnetic tape.

### 2.2.2 Instrumentation on the Gas Portion of the System

All of the instruments on the warm portion of the system and some of the instruments on the cold portion were read with computer B. In all 30 temperature sensors and 30 pressure sensors were interrogated twice a minute during the monitoring mode. Signals from these sensors were converted to engineering units and then displayed at the computer console which was a cathode ray tube (CRT). The majority of the instruments were used for monitoring the system operation and stability.

The signals from most of the pressure transducers were in the range of two to ten volts at the operating conditions and did not require signal conditioning. Low level signals from some of the pressure transducers and all of the temperature sensors required amplification prior to entering the computer multiplexer and digitizers. The amplifiers were all in a single chassis with four amplifiers per card; ten cards were used. Each amplifier had a fixed gain but the gain was changeable by replacing a plug-in module. Use of this type of system prevented inadvertent gain changes.

All signals were digitized and the computer converted them to engineering units by applying the appropriate mathematical equations. The polynomial equations were determined by calibrations. The pressure transducers were calibrated using a laboratory quality bourdon tube gauge. The temperatures were calculated using either the data from the Thermocouple Reference Table based on IPTS68 [5] or the calibration data from the manufacturer of the resistance thermometers. A precision constant current source controlled to 1 part in 7500 supplied the current for the resistance thermometers.

The instruments used for the gas flow measurement with the orifice meters were calibrated separately. These instruments and the method of calibration will be discussed in Section 3.

### 2.3 Automatic Data Acquisition

The two separate computers mentioned in Section 2.2 provided the automatic data acquisition, data display and data storage. Computer B had an input/output (I/O) bus that accommodated cards with 16 input channels per card. Five of these cards were used as input channels for the 30 pressure and 30 temperatures discussed in Section 2.2. Each of these cards has a digitizer and each channel can be accessed individually or in series with the rest of the card. For calibration, the channels were individually selected and the analog signal was digitized and fed to the computer where it was incorporated as input for the instrument calibration.

During system operation, it was necessary to monitor all of the system functions so all data channels were interrogated in sequence via the multiplexing capability at the I/O bus. The input signals were digitized as they were selected and this number was stored in an array. The number was then retrieved and each parameter was calculated using the polynomial equations determined by calibration.

The computer B was programmed to operate in three modes. The modes of operation were 1) monitoring the pressures and temperatures, 2) monitoring pressures and temperatures and storing the information on a disk and 3) taking flow test data during a test point. In the monitoring and storage mode computer B stored data on a magnetic disk in engineering units. Storage of these data facilitated investigation of system functions prior to test data points if desired. In the test point mode, data were also stored on a magnetic disk, but most of the data were stored as raw data signals from the sensors and their signal conditioning units, i.e., data were stored as digitized raw data. The program operated in the monitoring mode until the system stabilized at the desired flow rate. The test point mode was then selected. The computer read a barometer and accessed the data disk. It then informed the operator via the CRT that it was prepared to take test data.

Computer A interrogated a data logger and two digital voltmeters. The data logger read the signals from pressure and temperature sensors in the liquid nitrogen. It also read the current supplied to the resistance thermometers. The two digital voltmeters read the load cell and the load cell excitation voltage. The actual starting point for the test was determined by a low point setting on the load cell reading. When the output from the load cell reached this set point, a custom-built electronic unit started the recording system. When the load cell reading reached a preset upper value, the unit stopped the recording system to end the test point. The catch tank was allowed to partially fill before the test point started thereby eliminating the initial disturbance caused by valve closure. The overall cycle was started by manual switch selection.

During the test draft computer B repetitively interrogated four differential pressures, a static pressure and two temperatures and stored these as raw digital data on the magnetic disk. Two of the differential pressures

were measured at the orifice meter; the other two were for monitoring the system stability during the test draft. The static pressure was measured at the downstream orifice pressure tap. The temperatures were measured at the orifice meter and in the liquid nitrogen upstream of the catch tank.

At the conclusion of the test draft, computer B calculated the mass flow rate through the orifice meter using ANSI/API 2530 [6]. This calculation was made using the square of the average of the square roots of the differential pressure readings made during the test draft. The average of the static pressure and the temperature were used to calculate the density of the nitrogen near the orifice plate. The mass flow rate at the orifice and the barometric pressure were transmitted to computer A. Computer A transmitted back to B the test point number and the time of day. The test point number with the time was used to identify the data on both computer mass storage units.

Computer A stored the test information on a magnetic tape. Computer B stored the raw data on a disk. At the conclusion of the calculation, the test point, date and time were stored along with the averages of the pressures and temperatures. The data on the tape of computer A was transferred to computer B and added to the data disk at the end of the day. The disk now contained all of the test point data for a particular test. These data were transferred to a large main frame computer where the raw data were again converted to engineering units and averages were calculated. The averages were compared to those calculated in computer B. The comparison was made as a check on the accuracy of data transmission.

Data in SI units were eventually written to the archival file. These data were also further reduced and coefficients were calculated, plots were generated, etc. from the engineering unit data file.

## 2.4 Operation

The time integrated mass flow rate passing through the test meter must be the same as the mass accumulated in the weigh tank. Instrumentation has been developed and applied to actively control and measure parameters which are sensitive to changes in this flow stability, and provide a measure of error resulting from non-stable flow.

The result of non-stable flow could be an error in the measurement by the reference system. This error would consist of an amount of mass of nitrogen fluid which is either measured by the test meter and not measured by the reference system or not measured by the test meter but measured by the reference system. The error could only result from a mass of fluid nitrogen either being stored or expelled in the volume which connects the test meter with the reference system.

For each flow test configuration, the volume of piping between the test meter and the reference system remains constant. There will be no change in the physical volume during the test draft period. Any measurement error must result from a change in fluid density at some point within the fixed volume between the test meter and the reference system.

Referring to Figure 1, it is possible to isolate three separate subvolumes between the test meter and the reference system. The first subvolume is the ambient temperature volume measured from the active test meter element to the warm end of the main heat exchanger. A change in density within this volume can



be found by measuring the temperature and pressure at the beginning and end of the test draft period and calculating the density change from the state equation of nitrogen [7].

Subvolume two is bounded by the warm end of the main heat exchanger and the low temperature expansion valve. It can be monitored for change in pressure using the same method as for subvolume one. Change in temperature of this volume is considered a change in bulk temperature because of the large temperature difference throughout the exchanger length. Measurement is done by recording the change in pressure within the capped heat exchanger flow passage and calculating an equivalent temperature change for the period of the test draft. The state equation of nitrogen is used to calculate this temperature change and to calculate the density change in the flow passage volume.

The third subvolume is that defined by the expansion valve and the weigh tank. This volume is filled with compressed single phase liquid nitrogen and can be directly monitored for change of pressure and temperature at the beginning and end of the test draft. Density is calculated from the state equation.

During each test, the above three subvolumes are monitored for pressure and temperature change. Density changes for each subvolume are calculated and added to give the total estimated error in terms of mass. This value is then in turn compared to the mass of the test draft and if found to be less than 0.1 percent the test point is considered stable. If found to be greater than 0.1 percent this fact was used only as indicator. The calculated error is not applied as a correction because the uncertainty of the error is greater than the estimated error of the flow measurements themselves. However, the procedure provides a measurable quantity which aids in defining and maintaining mass flow stability during the test draft period.

The above measurements are passive controls on the degree of flow stability during the test draft period. The results of the measurements and calculations provided limits to the pressure and temperature excursions tolerated by the experimentalist during the test draft period. As a result of these measurements made during the early part of the program, it was found that additional active control was needed to assure stable flow. Referring to figure 1, during the test draft period, the valve on the weigh tank is closed and the liquid level increases in the weigh tank and correspondingly decreases in the catch tank. A decrease in the level of the catch tank decreases slightly the suction head of the boost pump and results in a slight reduction in the pump output. This reduction is carried through the system as a slight decrease in flow rate. For the fixed expansion valve setting, this reduction in flow gives a slight reduction in pressure at the gas test section. A control system was installed which increased the boost pump drive motor speed and pump output to compensate for the reduction in catch tank liquid level.

### 3. ORIFICE METER GAS FLOW TESTS

With pairs of each of the four line sizes and with six plates per meter run, it was possible to have 96 different combinations (not including repeat tests) of meter runs and plates. This number was reduced initially because of

pressure differential and reference system flow restrictions. A test plan was generated which was designed to limit the number of run and plate combinations based on meter performance. If a particular run-plate combination gave consistent results, then repeat runs were limited. There were 856 test points included in the current test series. Of these test points, 17 were eliminated because of instrumentation or equipment failure during the test draft. The remaining 839 test points are included in this report. These test points represent 109 combinations including repeat tests and over 73,000 individual measurements of pressure, differential pressure and temperature.

### 3.1 Orifice Flowmeter Test Equipment

As part of the flow measurement program at NBS Boulder, the meter runs, the orifice plates and the flow conditioners were measured to document the dimensional data for record. Included with those measurement data are the dimensional data of a significant portion of the piping upstream of the meters in the NBS flow facility. The latter is also documented in an archival file [3] with the flow data corresponding to the installation.

#### 3.1.1 Orifice Meter Runs

Each of the AGA/API meter runs is made up of three sections, an approach section, an upstream section and a downstream section. The approach section is affixed with a 600 psi ANSI flange on the upstream end and a special O-ring sealed flange on the downstream end. The upstream section mates with this O-ring sealed flange on the approach section at the upstream end and has a similar O-ring sealed flange on the downstream end which incorporates flange pressure taps built to the ANSI/API 2530 specification [6]. This flange is drilled in the bottom quadrants to accept two dowel pins which are used to position the orifice plate and align the runs. The upstream end of the downstream section mates with this flange and has corresponding flange taps and holes for dowel pins. The downstream end of this section is also equipped with a 600 psi ANSI flange. The flanges with taps have two tap holes, one at the top and one at the bottom. Figure 2 is a drawing of a typical flange at the orifice plate. The meter run diameter used for calculating data was the average of the diameters measured in the plain of the upstream flange taps. The meter runs were built to conform to the ANSI/API 2530 specification where applicable. A detailed description of the meter runs is given in Appendix 1.

#### 3.1.2 Orifice Plates

Two identical sets of six orifice plates were supplied with the meter runs. These plates were sized to cover a beta ratio (orifice diameter to pipe diameter) of about 0.2 to 0.75. The plates are all nominally 1/8 inch thick and have a 45 degree bevel on the outlet side. The plates are affixed with a paddle-type handle which is stamped with the identifying code and the nominal orifice size in inches. The plates were installed with the handle at the top for all of the tests. A detailed description of the plates and their identification is presented in Appendix 2.

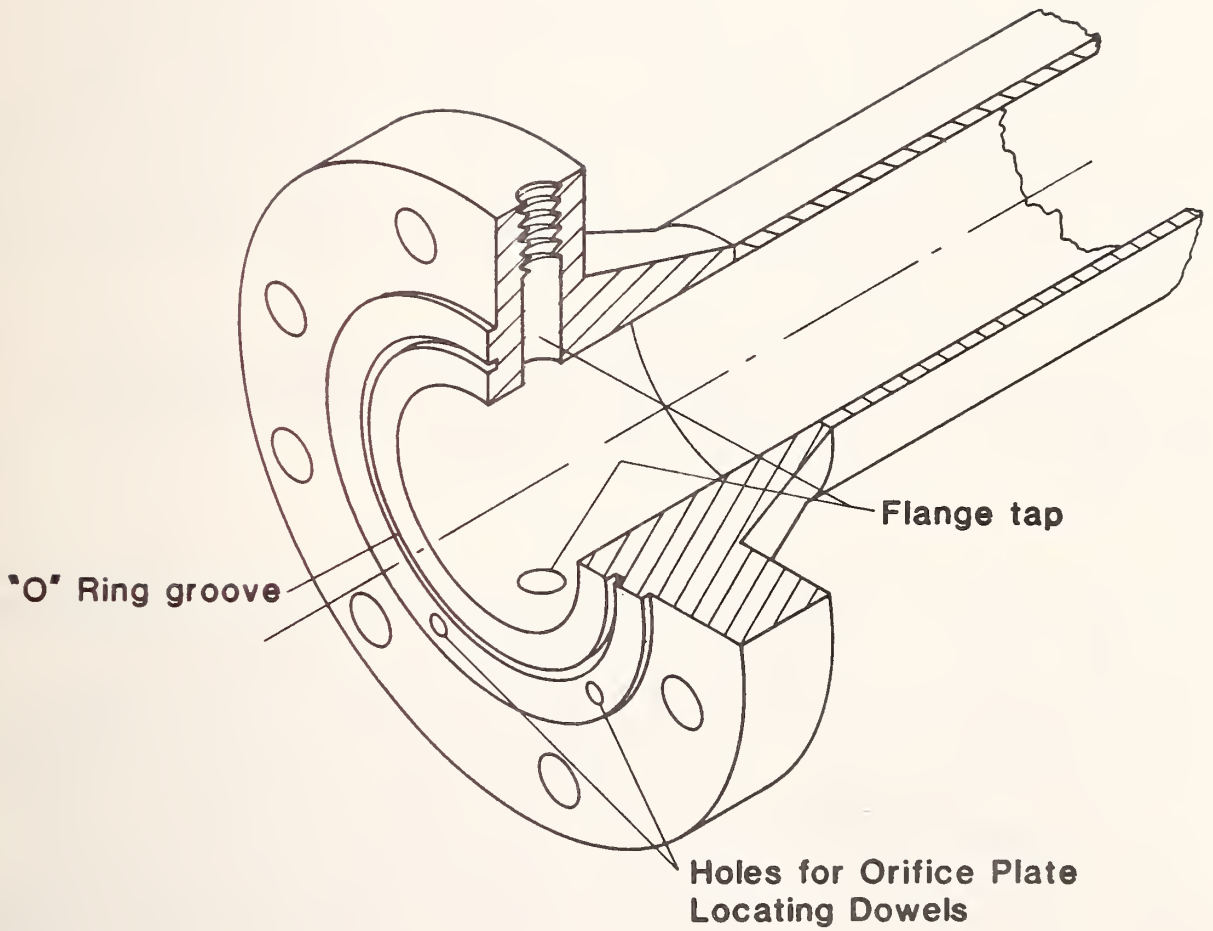

Figure 2. Typical orifice meter flange.

### 3.1.3 Flow Conditioners

A perforated plate type flow conditioner [8,9] was installed upstream of the approach section of the meter run during all of the tests recorded in the archival data file. Figure 3 shows the general layout of the plates and assembly. Three sizes of conditioners were used for the tests, a 4-inch, a 6-inch and a 10-inch.

Usually the 4-inch conditioner was used with the 2-inch and 3-inch meter runs, the 6-inch conditioner with the 4-inch meter run and the 10-inch conditioner with the 6-inch meter run. There were exceptions to this statement and they are documented in the archival data file and are apparent in the installation descriptions in Section 3.1.4. Since the flow conditioner housings were a larger pipe size than the meter runs, there were reducers on each end of the housing. The housings thus were constructed using a 600 psi ANSI flange welded to a reducer which was welded to a 600 psi ANSI flange the size of the housing. This flange mated to a similar flange which was welded to a length of run the nominal size of the unit. This straight run was welded to a reducer which was welded to a 600 psi ANSI flange the same size as the inlet flange. The 4-inch unit has 3-inch inlet and outlet flanges; the 6-inch unit has 4-inch inlet and outlet flanges; and the 10-inch unit has 6-inch inlet and outlet flanges.

The perforated plates were attached to each other with spacer rods. The upstream plate was of the diameter to fit between the housing flanges thus securing it in the housing. The other two plates fit inside the housing. All dimensions for the units are given in Appendix 3.

### 3.1.4 Gas System Piping

The portion of the NBS flow facility between the steam heat exchanger and the downstream end of the meter runs (see Figure 1) is described in detail here and in the archival data file [3]. From the steam heat exchanger the 4-inch pipe makes a right angle bend to the horizontal where it connects to the horizontal piping upstream of the meter runs. In general, the gas flow test section piping is in the form of a "U" shape in a horizontal plane containing (from the upstream flange) a 4-inch straight section and a 4-inch gas turbine meter with a 4-inch blocking valve and bypass. The bypass includes a 2-inch block and bleed valve and 2-inch piping. Downstream of the bypass are two right angle elbows, a flow conditioner, the orifice meter and the gas test section downstream flange. The overall length of pipe depends on the nominal orifice meter length. Four-inch (unless otherwise specified) schedule 40 pipe spool pieces of various lengths are used to give equal length to the legs of the "U".

Six specific configurations were used. Each configuration used is identified in the archival data file. A schematic of the six configurations excluding the 2-inch bypass is shown in Figure 4. The following is a description of each configuration:

Test Piping Configuration Code 1981-A. Upstream flange + 7.15 meter spool piece + gas turbine meter (S/N 77-G-32B) + 4-inch ball valve + 0.75 meter spool

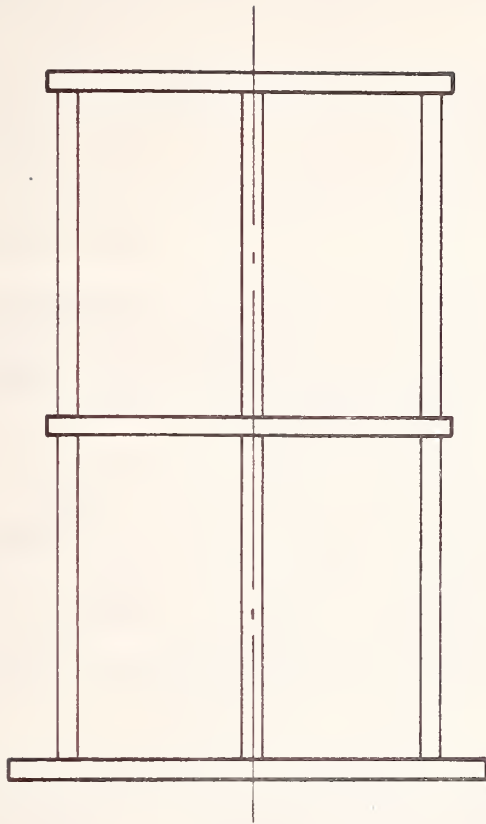

**NOTE:**

Hole pattern is identical and aligned in all plates

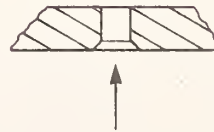
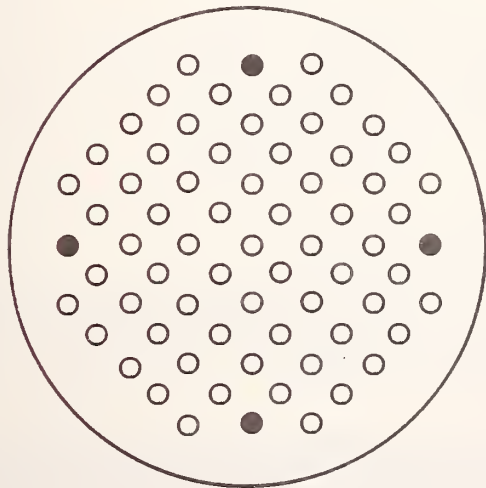

Typical hole cross section

Figure 3. Flow conditioner.

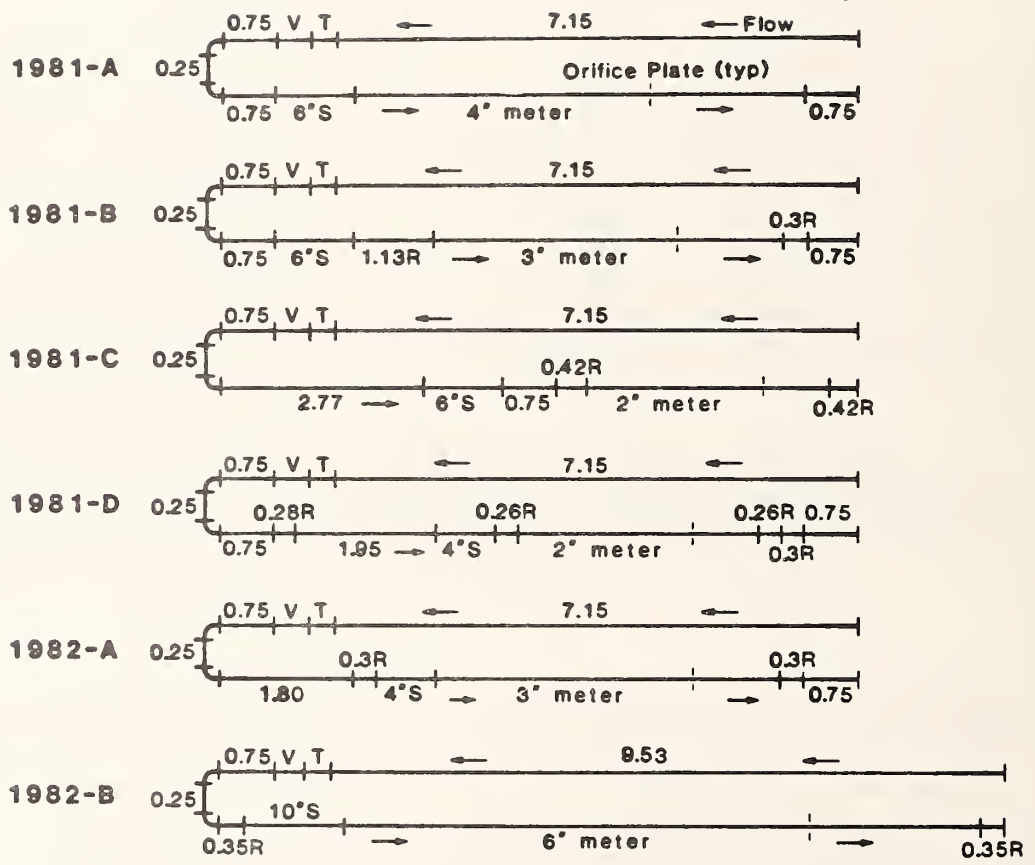

S - Flow conditioner  
 V - 4 inch ball valve  
 T - 4 inch gas turbine meter (S/N 77-G-32B)  
 R - Reducing sections

NOTE:  
 All facility pipes are nominal 4 inch excepting two sections. The 1.95 meter section at 1981D and the 1.13R section at 1981B, which is a 4 to 3 inch reducer, are 3 inch pipe. All dimensions in meters unless otherwise specified. Detailed dimensions of the meters are in Appendix 1.

Figure 4. Gas system piping schematic.

piece + right angle elbow + 0.25 meter spool piece + right angle elbow + 0.75 meter spool piece + 6-inch flow conditioner + AGA/API 4-inch orifice run + 0.75 meter spool piece + downstream flange.

Test Piping Configuration Code 1981-B. Upstream flange + 7.15 meter spool piece + gas turbine meter (S/N 77-G-32B) + 4-inch ball valve + 0.75 meter spool piece + right angle elbow + 0.25 meter spool piece + right angle elbow + 0.75 meter spool piece + 6-inch flow conditioner + 1.13 meter reducer (4 x 3) + AGA/API 3-inch orifice run + 0.30 meter reducer (3 x 4) + 0.75 meter spool piece + downstream flange.

Test Piping Configuration Code 1981-C. Upstream flange + 7.15 meter spool piece + gas turbine meter (S/N 77-G-32B) + 4-inch ball valve + 0.75 meter spool piece + right angle elbow + 0.25 meter spool piece + right angle elbow + 2.77 meter spool piece + 6-inch flow conditioner + 0.75 meter spool piece + 0.42 meter reducer (4 x 2) + AGA/API 2-inch orifice run + 0.42 meter reducer (2 x 4) + downstream flange.

Test Piping Configuration Code 1981-D. Upstream flange + 7.15 meter spool piece + gas turbine meter (S/N 77-G-32B) + 4-inch ball valve + 0.75 meter spool piece + right angle elbow + 0.25 meter spool piece + right angle elbow + 0.75 meter spool piece + 0.28 meter reducer (4 x 3) + 1.95 meter spool piece (3-inch) + 4-inch flow conditioner + 0.26 meter reducer (3 x 2) + AGA/API 2-inch orifice run + 0.26 meter reducer (2 x 3) + 0.30 meter reducer (3 x 4) + 0.75 meter spool piece + downstream flange.

Test Piping Configuration Code 1982-A. Upstream flange + 7.15 meter spool piece + gas turbine meter (S/N 77-G-32B) + 4-inch ball valve + 0.75 meter spool piece + right angle elbow + 0.25 meter spool piece + right angle elbow + 1.80 meter spool piece + 0.30 meter reducer (4 x 3) + 4-inch flow conditioner + AGA/API 3-inch orifice run + 0.30 meter reducer (3 x 4) + 0.75 meter spool piece + downstream flange.

Test Piping Configuration Code 1982-B. Upstream flange + 9.53 meter spool piece + gas turbine meter (S/N 77-G-32B) + 4-inch ball valve + 0.75 meter spool piece + right angle elbow + 0.25 meter spool piece + right angle elbow + 0.35 meter reducer (4 x 6) + 10-inch conditioner + AGA/API 6-inch orifice run + 0.35 meter reducer (6 x 4) + downstream flange.

### 3.2 Orifice Meter Instrumentation

The performance of orifice meters of defined geometry measuring a single component fluid requires three parameters; static pressure, flowing fluid temperature and differential pressure across the orifice plate. With these three parameters the mass flow rate was calculated from the known properties of the process fluid [7].

The automated data acquisition system described in Section 2.3 recorded the measurements from the orifice meter instruments. Electronic signals were supplied to the computer from pressure and temperature transducers and associated signal conditioning equipment. The static pressure and the differential pressure were measured with transducers whose output was current proportional to pressure. Current from each of the transducers passed through

a precision resistor and the voltage across the resistor was read and digitized, then fed to the computer. The computer also recorded the voltage across the platinum resistance thermometer used to measure fluid temperature. All of the digitized voltage signals were recorded on mass storage disks and subsequently transmitted to a larger main frame computer where all data reduction, analysis and presentation were performed.

The differential pressure across the orifice plate was measured at the flange taps using two differential pressure transducers. The lower range transducer which was 0 to 25 kPa was used until the range was exceeded, then the high range transducer 0 to 50 kPa was automatically selected. Both of these transducers experienced small but significant changes in the zero signal. This change necessitated daily calibrations and use of the calibration for that days tests. The differential pressure transducers were calibrated using a cistern mercury manometer at a base pressure of 4.1 MPa which was near the system operating pressure. This mercury manometer was calibrated at ambient base pressure with an air dead weight gauge certified by NBS. Corrections were made to the mercury manometer reading to adjust the ambient pressure calibration to the 4.1 MPa base pressure. These corrections were verified by using two dead weight gauges, one for the base pressure and the other for the base plus the differential pressure. This technique and documentation of the accuracy of the pressure calibration facility has been reported by Sindt and LaBrecque [10].

The 640 individual differential pressure calibration data points were fitted to a straight line. Statistical analysis show a residual standard deviation of 22 Pa where as for any of the single calibrations using 12 points fitted to a straight line, the residual standard deviation ranged from 5 to 15 Pa. The total uncertainty limit of any single reading of these transducers is predicted to be 38 to 54 Pa depending on the reading. The total uncertainty limit for 30 measurements, the minimum taken per test point, is estimated to be 0.07% at 50 kPa, 0.1% at 25 kPa and 0.7% at 2.5 kPa. This total uncertainty limit includes the uncertainty contributed by the transducers, the mercury manometer and the dead weight gauge.

The static pressure was measured at the downstream orifice flange tap using a transducer with a range of 0 to 6.895 MPa. This transducer was calibrated daily using an air dead weight gauge that was certified by NBS [10]. Nine hundred and thirty-five calibration data points from this transducer were fitted to a straight line. The resulting residual standard deviation from this fit was within  $\pm 0.12\%$  at the 4.1 MPa operating pressure.

The gas temperature was measured downstream from the end of the orifice meter runs using a platinum resistance thermometer driven by a current source which maintained a constant current within  $\pm 0.01\%$ . The thermometer was calibrated by comparison with a transfer standard certified by NBS. Comparisons were made at the water ice point and at points up to 37 K above the ice point. From these comparisons the estimated uncertainty of the thermometer readings was  $-0.26$  K to  $+0.15$  K for one reading; for thirty readings the estimated uncertainty was  $-0.12$  K to  $+0.0$  K. The procedure for calibration was to first check the water ice point reading of both the thermometer and the transfer standard, then comparisons were made at about six points up to 310 K. The ice point was again checked as the last reading.



For all of the meter installations shown on Figure 4, the thermometer was located 0.6 m downstream from the last flange indicated on the schematic. The distance from the orifice plate to the thermometer was the length of the downstream meter section plus any spool piece and reducer shown on Figure 4 plus 0.6 m.

### 3.3 Flow Test Procedures

As previously stated tests were conducted on two sets each of four sizes of meter runs. Each meter run is identified as FE1 through FE8 and includes upstream and downstream piping. Each meter run had six pairs of orifice plates covering a range of beta ratios of approximately 0.2 to 0.75. Plates of the same nominal size were identified with the same numeric value from 1 to 6. Individual plates of the same size were further identified with a suffix of A or B.

For the tests reported here the orifice pressure differential was limited to the range 2.5 to 50 kPa. The flow facility has a gas flow range limitation of 0.45 to 2.5 kg/s. These two limitations precluded testing all the orifice plates in any meter size. For a variety of other reasons not all plate-meter run combinations were tested. Table 1 lists the orifice plate-meter run combinations that were available. An "X" in the body of the table indicates the combinations that were tested.

Table 1. Orifice Plate-Meter Run Test Combinations

Run/Orifice	1A	1B	2A	2B	3A	3B	4A	4B	5A	5B	6A	6B
FE1							X	X	X	X	X	X
FE2							X	X	X	X		
FE3			X	X		X		X	X	X		X
FE4			X	X	X	X	X	X	X	X	X	X
FE5			X	X	X	X	X	X	X	X	X	X
FE6			X	X	X	X	X	X	X	X	X	X
FE7	X	X	X	X	X	X	X	X				
FE8	X	X	X		X	X	X	X				

The test plan used in this study was randomized in flow rate, plate selection and run selection. A series of randomized flow rate tests were conducted for each orifice plate-meter run combination. The method of taking data with continuously increasing or decreasing flow rates was not used. Repeated flow rate points were also randomized. With one exception, repeated tests with a given orifice plate were not done without at least removing and replacing the plate in the meter run. Normally, repeated tests were not done consecutively.

The data were analyzed by calculating the product of the discharge coefficient, C, and the expansion factor, Y<sub>2</sub>, and plotting the results as a function of the bore Reynolds Number. It was not possible to separate the values of C and Y<sub>2</sub> in this phase of the test program although tests are underway which will allow this to be done.

The CY<sub>2</sub> product was calculated using equation (1).

$$CY_2 = \frac{(\text{constant})(\dot{m})(1-\beta^4)^{\frac{1}{2}}}{(F_a)(d^2)(\rho\Delta P)^{\frac{1}{2}}} \quad (1)$$

where C = discharge coefficient  
 Y<sub>2</sub> = expansion factor based on downstream pressure  
 m = mass flow rate  
 β = diameter ratio or beta  
 d = orifice diameter  
 F<sub>a</sub> = orifice plate thermal contraction factor [6]  
 ρ = gas density  
 ΔP = orifice differential pressure  
 constant = numeric function of dimensions and conversion factors.

When the mass flow rate is in units of kg/s, orifice diameter is in units of cm, gas density is in units of kg/m<sup>3</sup> and differential pressure is in units of kPa, then the

$$\text{constant} = \frac{(4) (10,000 \text{ cm}^2/\text{m}^2)}{\pi((2) 1,000 \text{ Pa/kPa})^{\frac{1}{2}}} = 284.705 \quad (\text{SI units})$$

When the mass flow rate is in units of lb<sub>m</sub>/s, orifice diameter is in units of inches, gas density is in units of lb<sub>m</sub>/ft<sup>3</sup> and differential pressure is in units of inches of H<sub>2</sub>O, then the

$$\text{constant} = \frac{(4) (144 \text{ in}^2/\text{ft}^2)}{\pi(\rho_w/12)^{\frac{1}{2}} (2 \text{ g}_c)^{\frac{1}{2}}} = 10.0258 \quad (\text{British units})$$

where ρ<sub>w</sub> = 62.3664 lb/ft<sup>3</sup>; the density of water at 60°F(1 atm.) [11].  
 g<sub>c</sub> = 32.174 lb<sub>m</sub>·ft/lb<sub>f</sub>·s<sup>2</sup>; the gravitational constant.

### 3.4 Test Results

The test identification is used to specify a single test or group of tests and is carried through all of the tables. The key for the test identification is as follows:

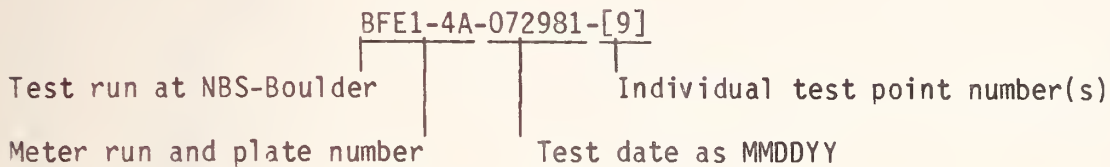

Tabular values for all values of the physical measurements of the orifice plates and meter runs available to this project are given in tables 2 (a), 3 (a), 4 (a) and 5 (a) in the International System of Units (SI). The same information is also provided in U.S. Customary Units (British) in tables 6 (a), 7 (a), 8 (a) and 9 (a). All measured parameters taken during the test program and all calculated values are tabulated in tables 2 (b), 3 (b), 4 (b) and 5(b) in SI units and in tables 6 (b), 7 (b), 8 (b) and 9 (b) in British units.

The number of significant digits shown in the tables are more than can be justified by the accuracy limitations but are carried for computational consistency. The differential pressures in these tables are based on a density of water at 288.71K (101.325 kPa) as being  $0.999014 \times 10^3 \text{ kg/m}^3$  [11].

CY<sub>2</sub> and KY<sub>2</sub> values were calculated for each of the "N" data samples. The tabulated values were determined by taking a simple average of the individual calculations for each test point.

All the CY<sub>2</sub> values in the tables are plotted as a function of the reciprocal bore Reynolds Number in figures 5 through 8. Also included in the figures are curves denoting the values of CY<sub>2</sub> that were calculated using the two methods specified by the ANSI/API 2530 and the ISO 5167 standards [12]. The value of Y<sub>2</sub> used in both curves was calculated as specified in the ANSI/API 2530 standard and is responsible for the upward curvature at high bore Reynolds Numbers.

From the figures it is apparent that the standards do not adequately predict experimental data for all line sizes and beta ratios. The data have size and beta ratio dependencies different from those predicted by the standards.

Figure 9 shows the relative relationship of the data presented here with the original water data [13] from which both standards were developed.

### 3.5 Future Plans

During 1984 and 1985, NBS plans to continue evaluation and analysis of these data under GRI sponsorship. The ultimate goal of this research is to establish an accurate relationship for measuring high volume gas flows using orifice meters.

+ SET A  
 Δ SET B  
 — ANSI/API 2530  
 - - - - ISO-5167

$\beta = 0.54$

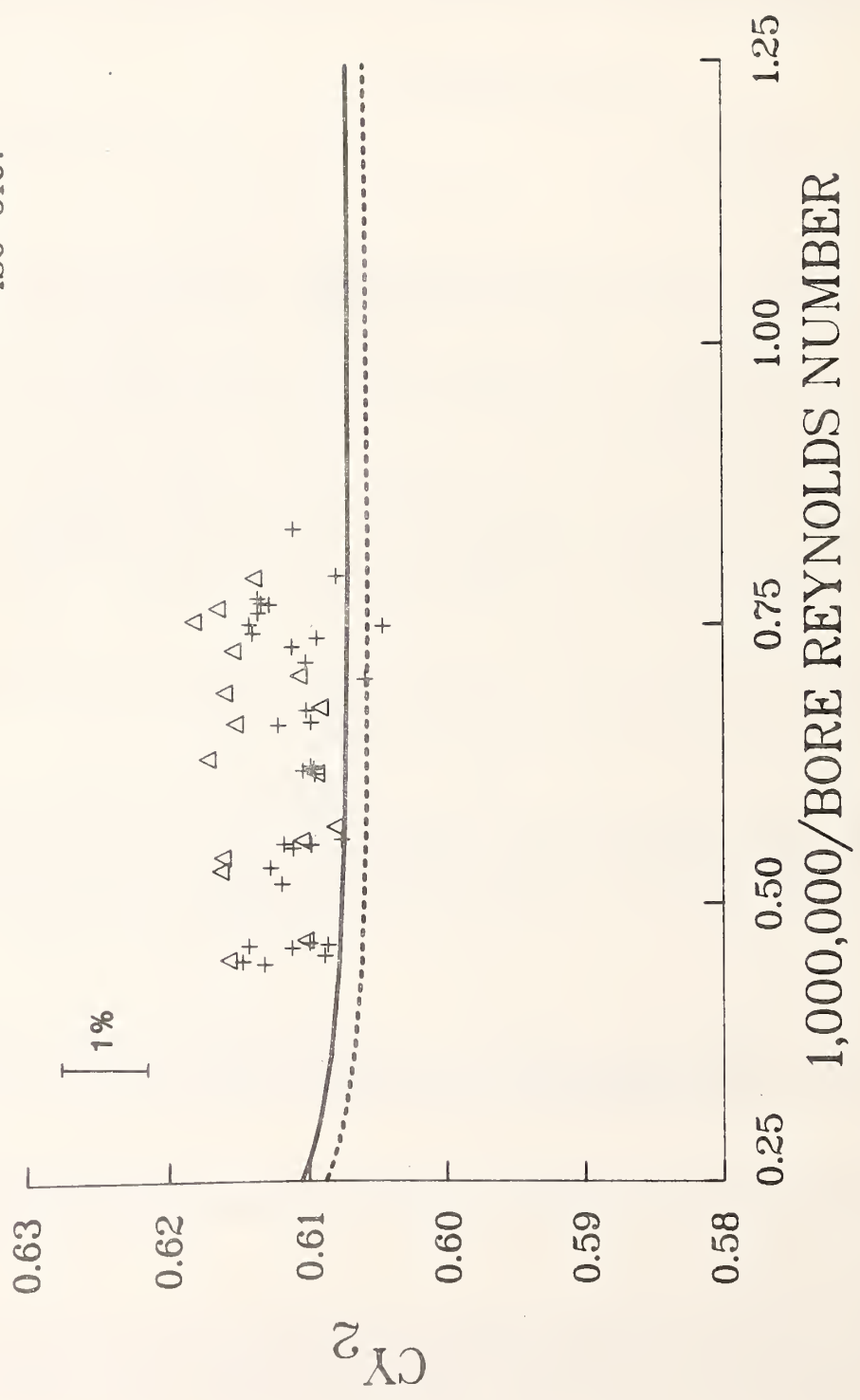

Figure 5(a). Results from the 2 inch meter with the 1-1/8 inch orifice plate.

+ SET A  
 Δ SET B  
 — ANSI/API 2530  
 - - - ISO-5167

$\beta = 0.66$

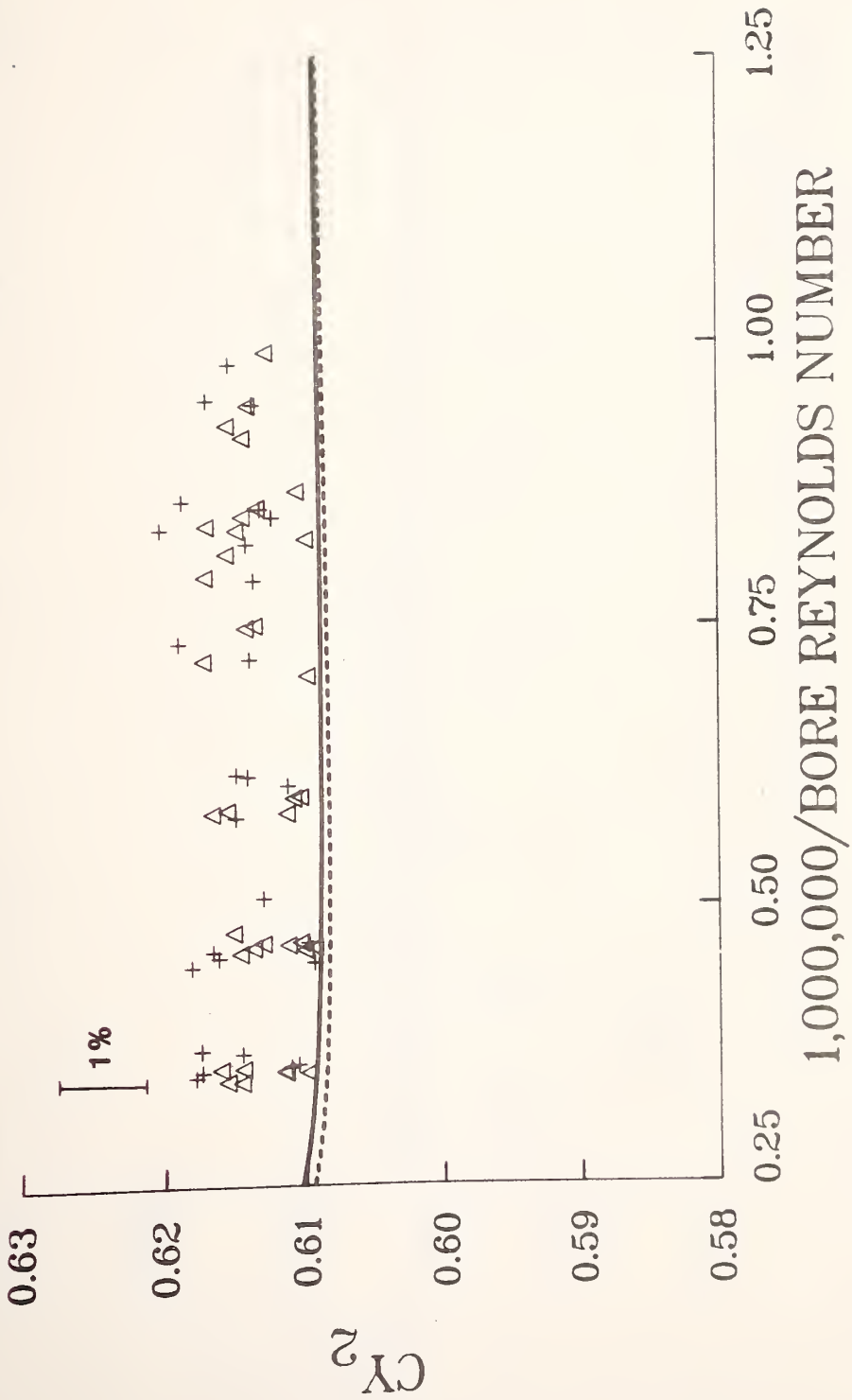

Figure 5(b). Results from the 2 inch meter with the 1-3/8 inch orifice plate.

+ SET A  
 Δ SET B  
 — ANSI/API 2530  
 - - - - ISO-5167

$$\beta = 0.73$$

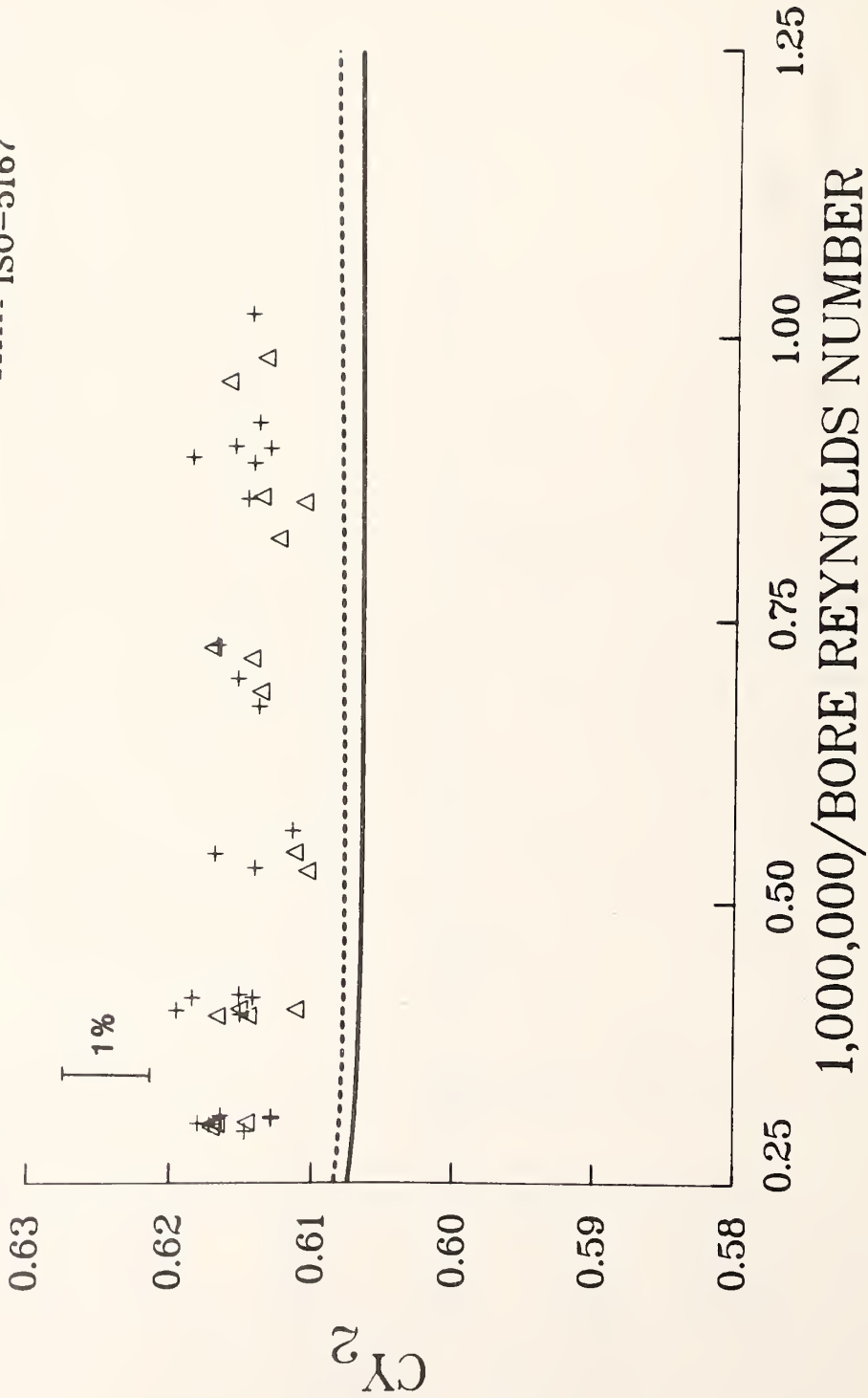

Figure 5(c). Results from the 2 inch meter with the 1-1/2 inch orifice plate.

+ SET A  
 Δ SET B  
 — ANSI/API 2530  
 - - - - ISO-5167

$\beta = 0.37$

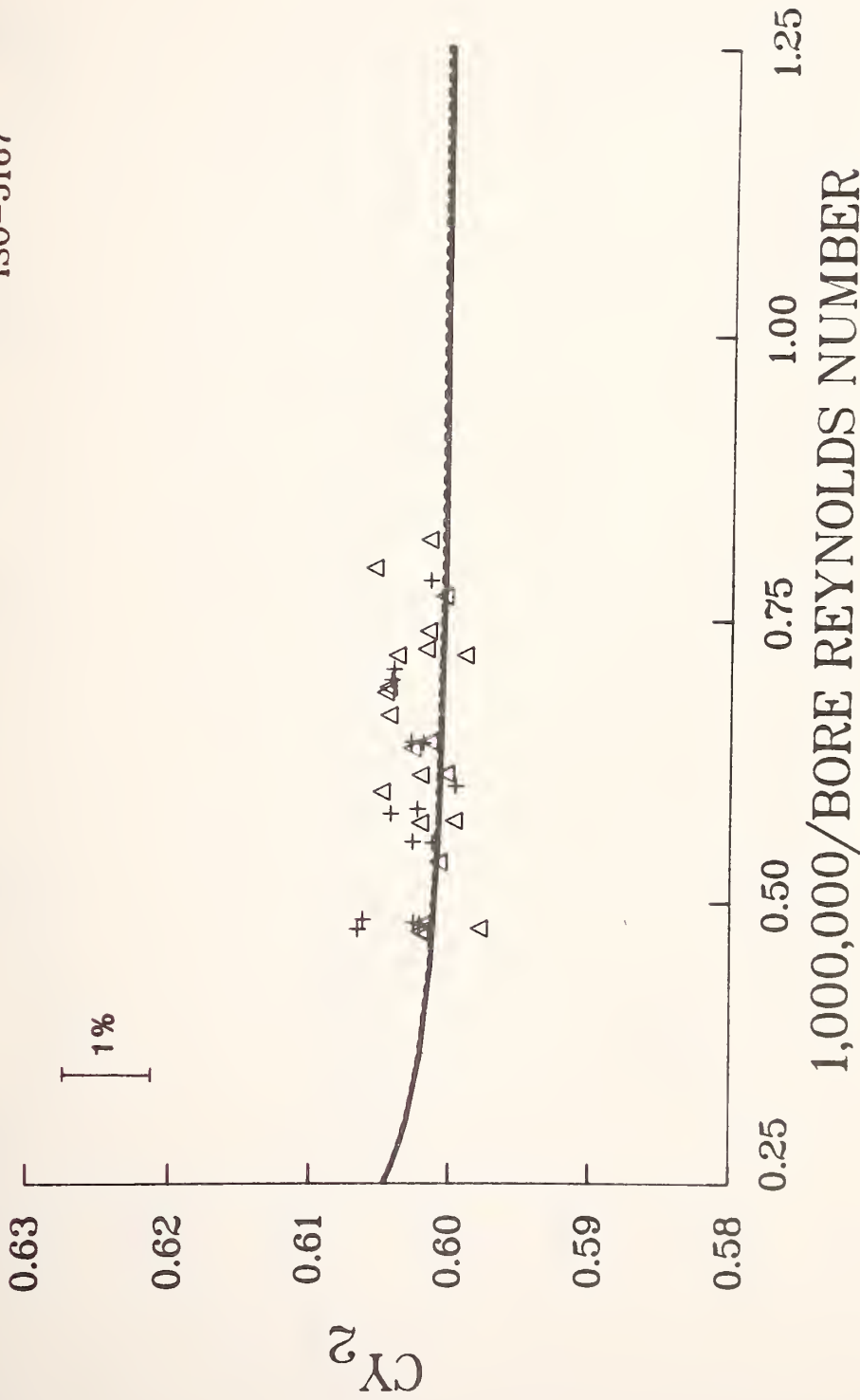

Figure 6(a). Results from the 3 inch meter with the 1-1/8 inch orifice plate.

+ SET A  
 Δ SET B  
 — ANSI/API 2530  
 - - - - ISO-5167

$$\beta = 0.49$$

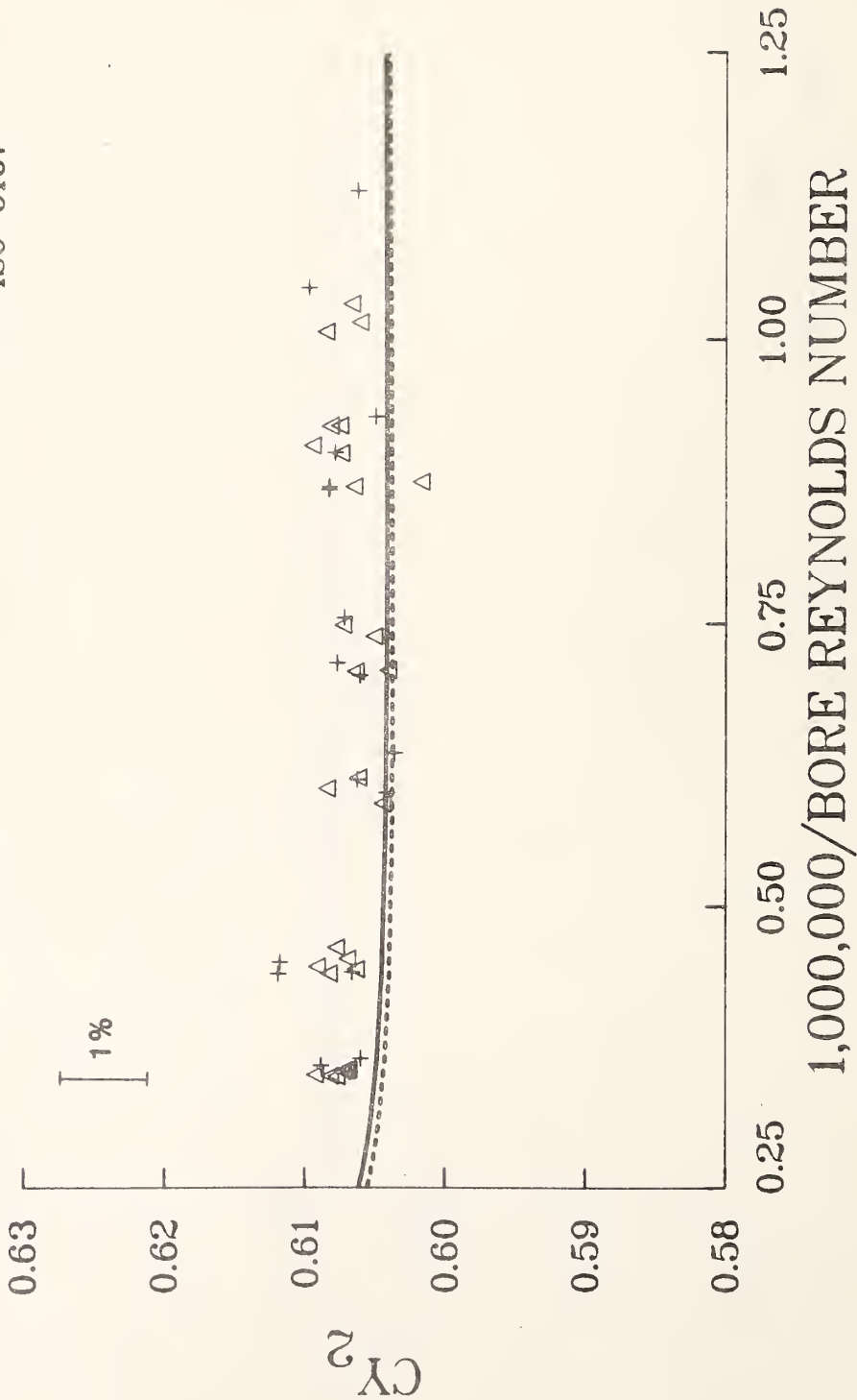

Figure 6(b). Results from the 3 inch meter with the 1-1/2 inch orifice plate.



+ SET A  
 Δ SET B  
 — ANSI/API 2530  
 - - - - ISO-5167

$\beta = 0.57$

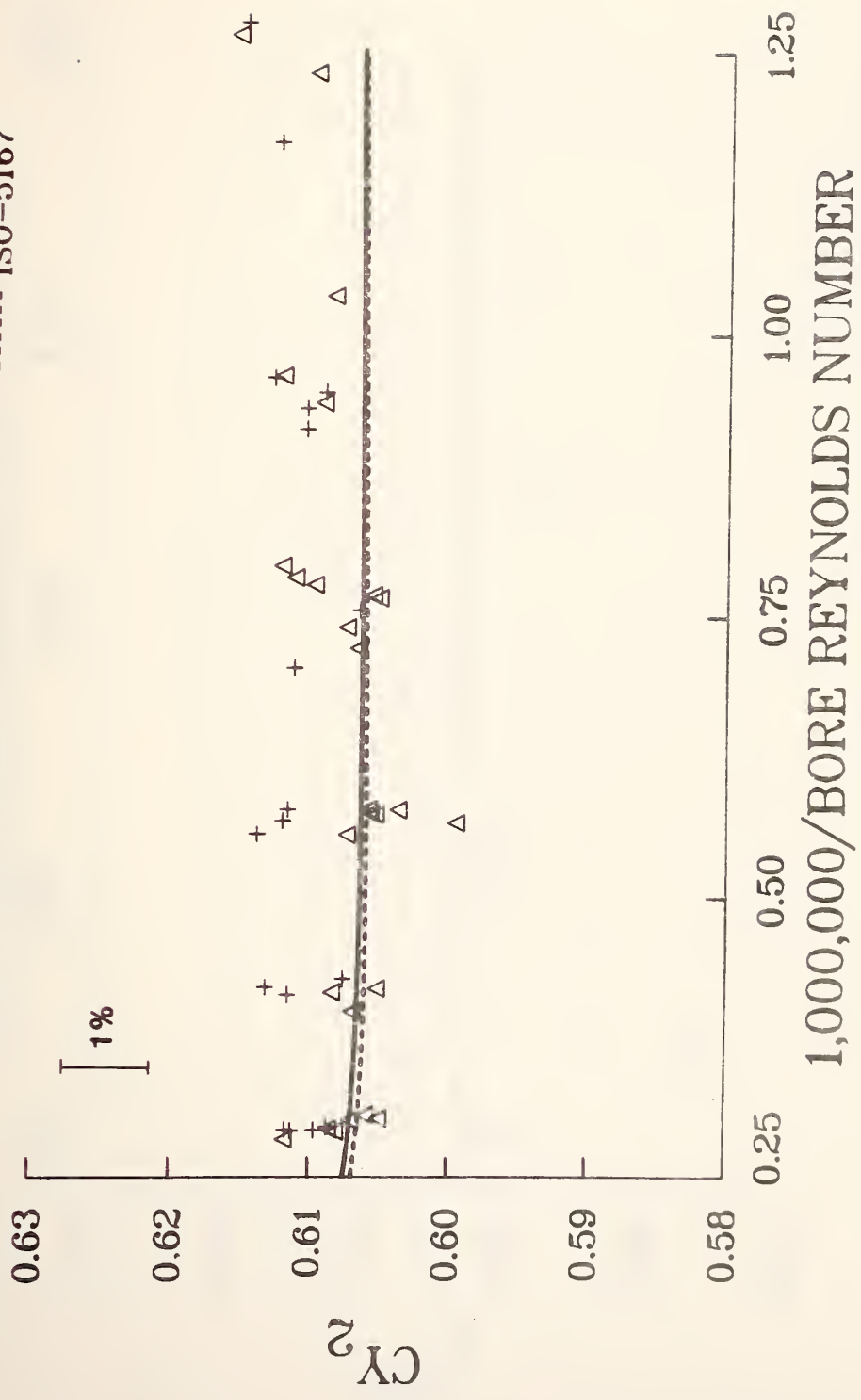

Figure 6(c). Results from the 3 inch meter with the 1-3/4 inch orifice plate.

+ SET A  
 Δ SET B  
 — ANSI/API 2530  
 - - - - ISO-5167

$\beta = 0.65$

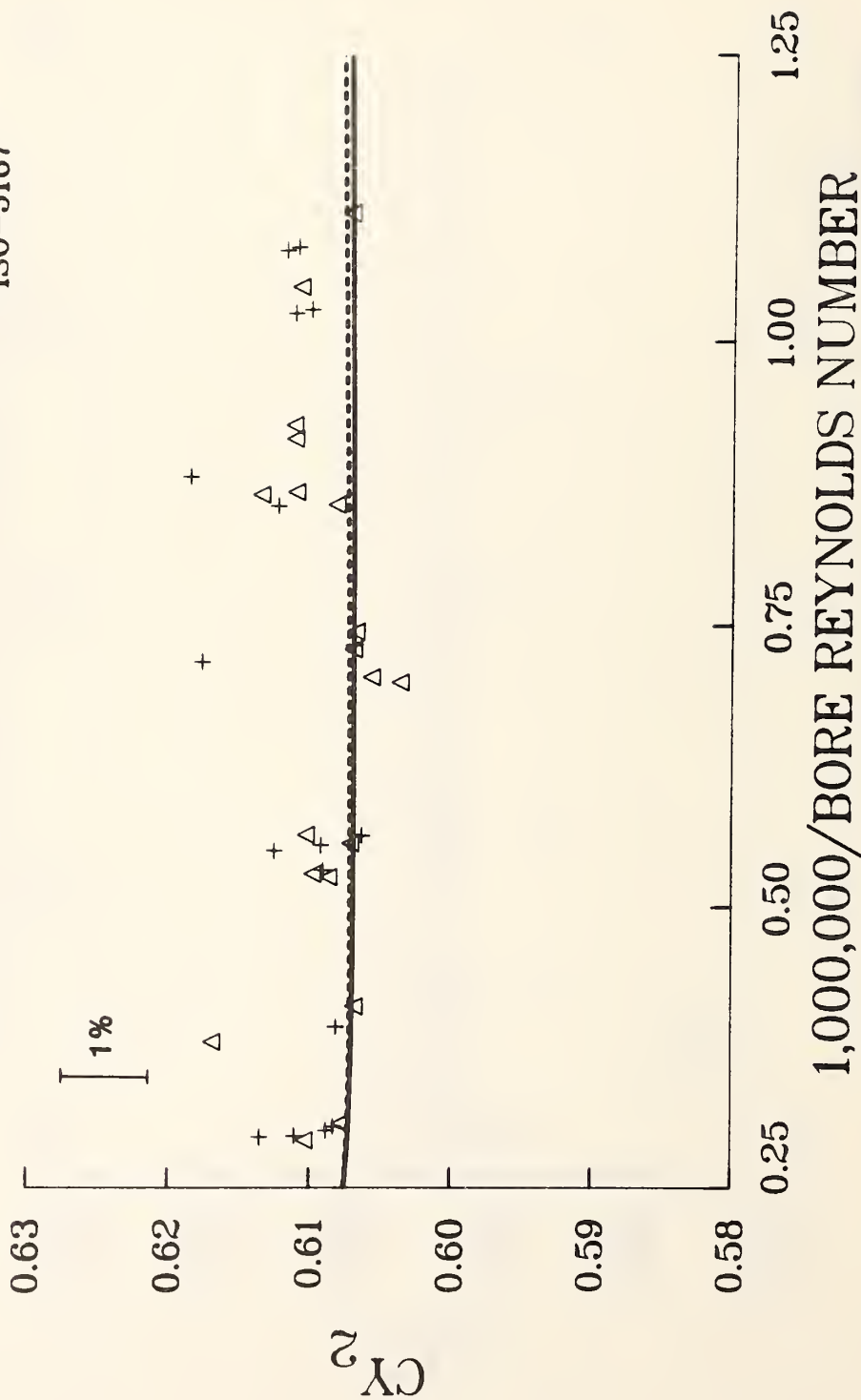

Figure 6(d). Results from the 3 inch meter with the 2 inch orifice plate.

+ SET A  
 Δ SET B  
 — ANSI/API 2530  
 - - - - ISO-5167

$$\beta = 0.73$$

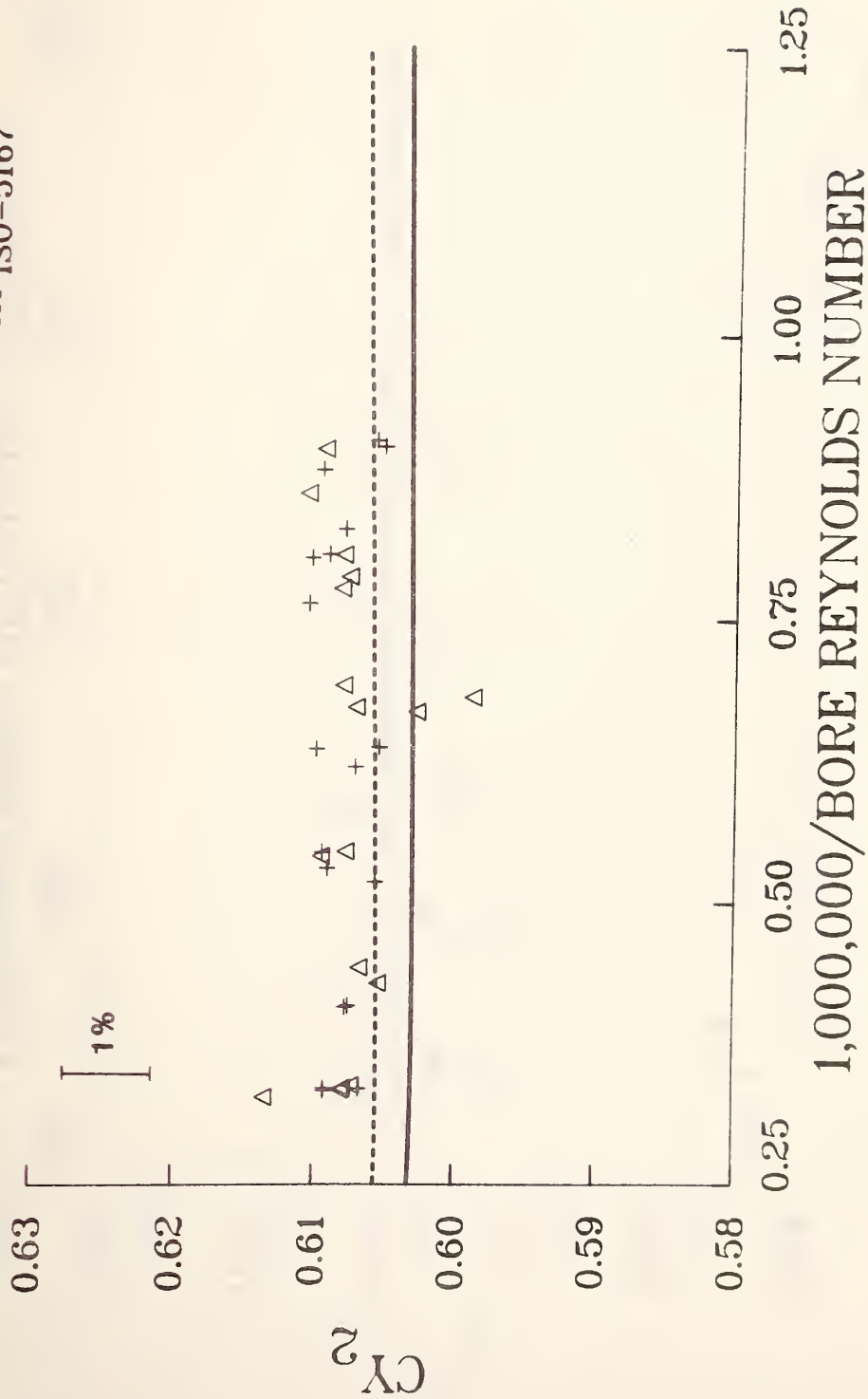

Figure 6(e). Results from the 3 inch meter with the 2-1/4 inch orifice plate.

+ SET A  
 Δ SET B  
 — ANSI/API 2530  
 - - - - ISO-5167

$$\beta = 0.37$$

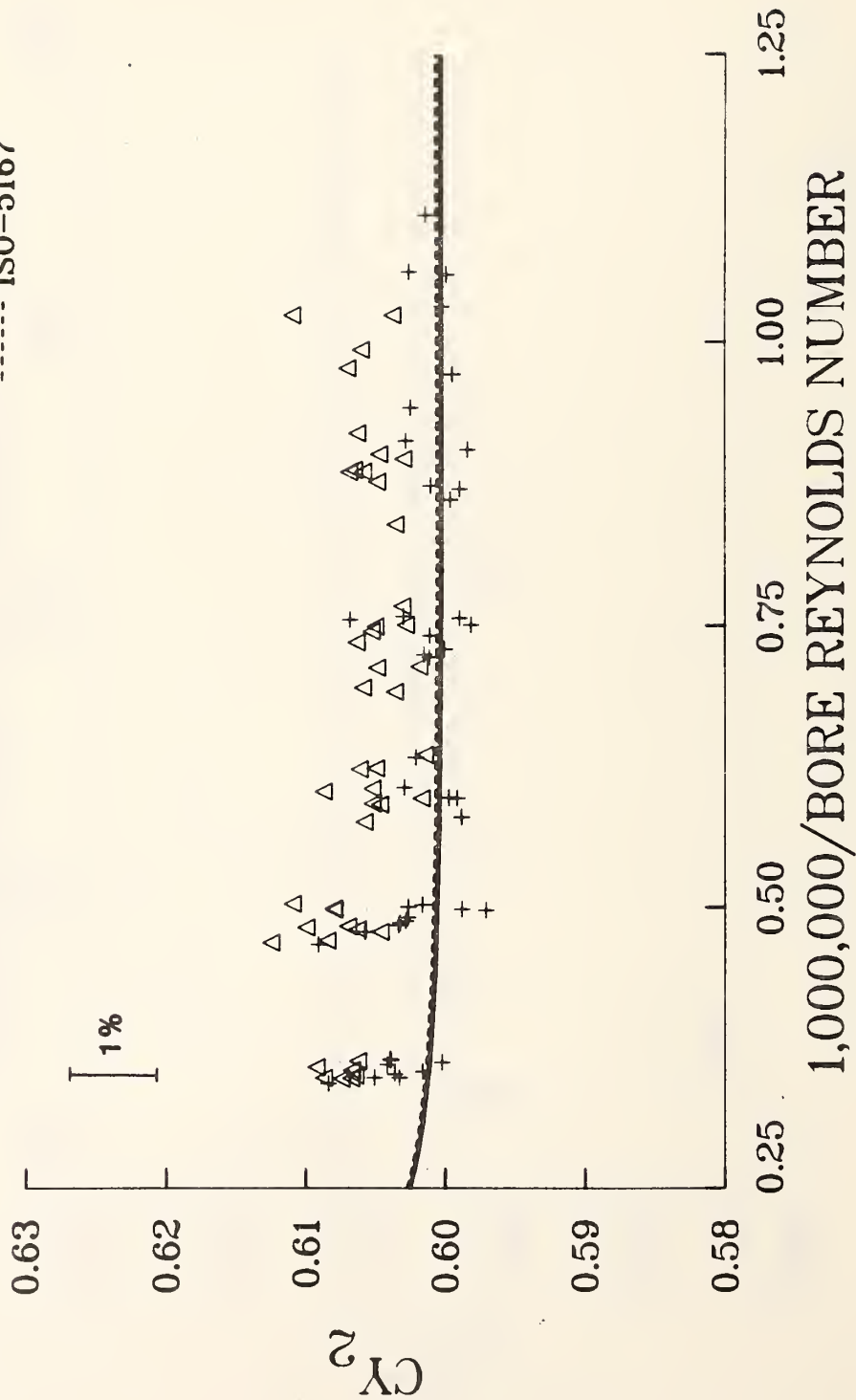

Figure 7(a). Results from the 4 inch meter with the 1-1/2 inch orifice plate.

+ SET A  
 Δ SET B  
 — ANSI/API 2530  
 - - - ISO-5167

$\beta = 0.50$

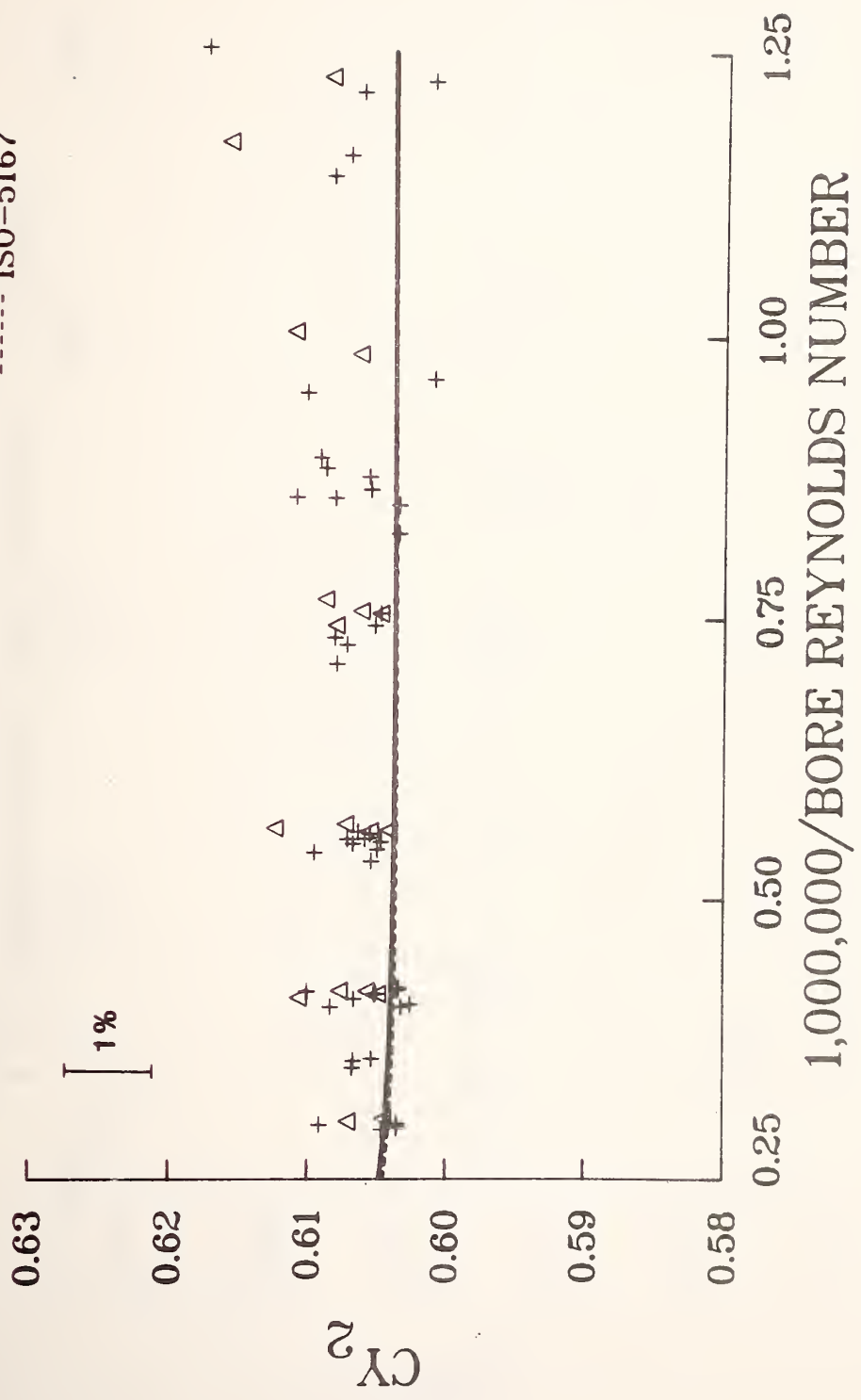

Figure 7(b). Results from the 4 inch meter with the 2 inch orifice plate.

+ SET A  
 Δ SET B  
 — ANSI/API 2530  
 - - - - ISO-5167

$$\beta = 0.56$$

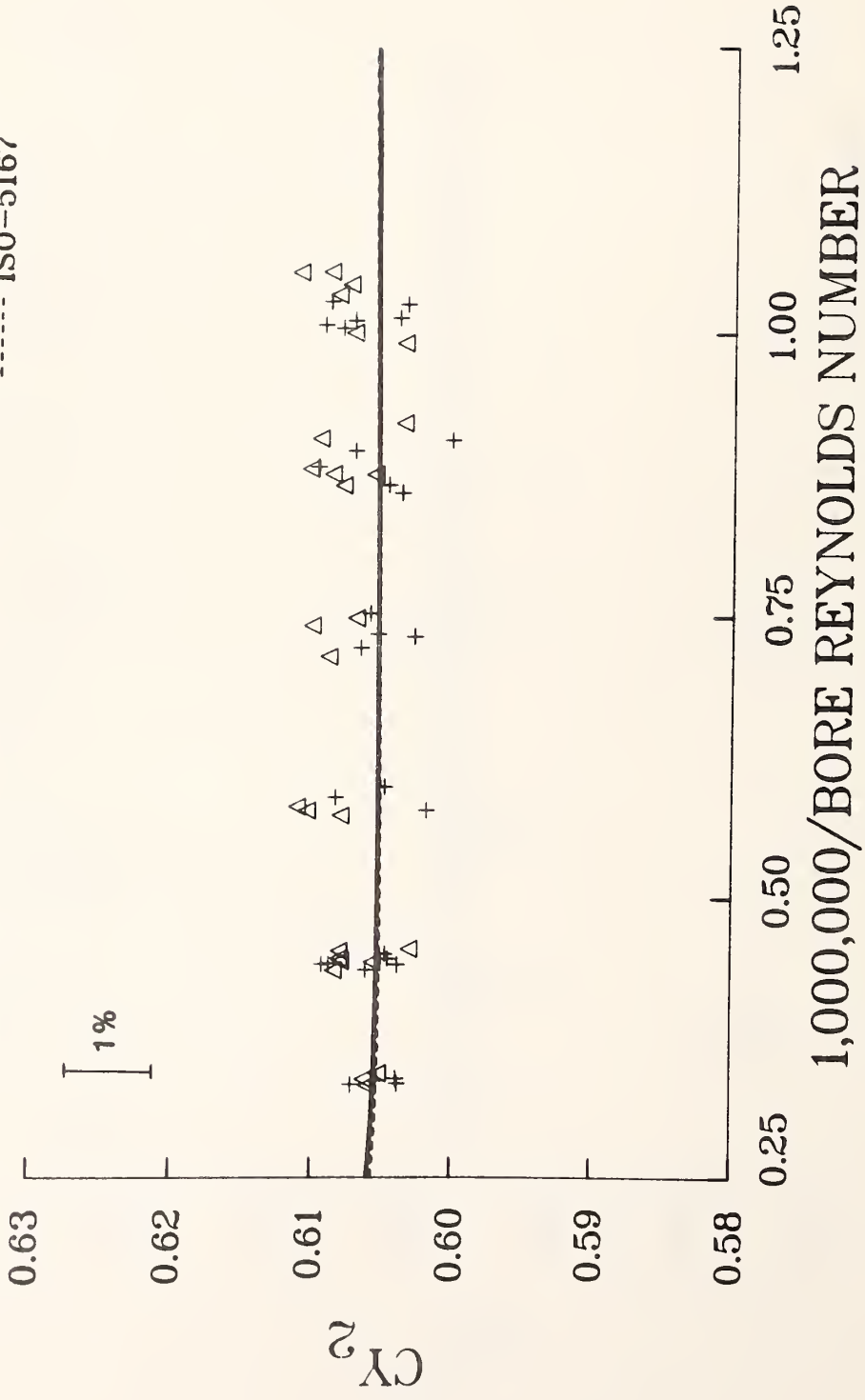

Figure 7(c). Results from the 4 inch meter with the 2-1/4 inch orifice plate.

+ SET A  
 Δ SET B  
 — ANSI/API 2530  
 - - - ISO-5167

$\beta = 0.65$

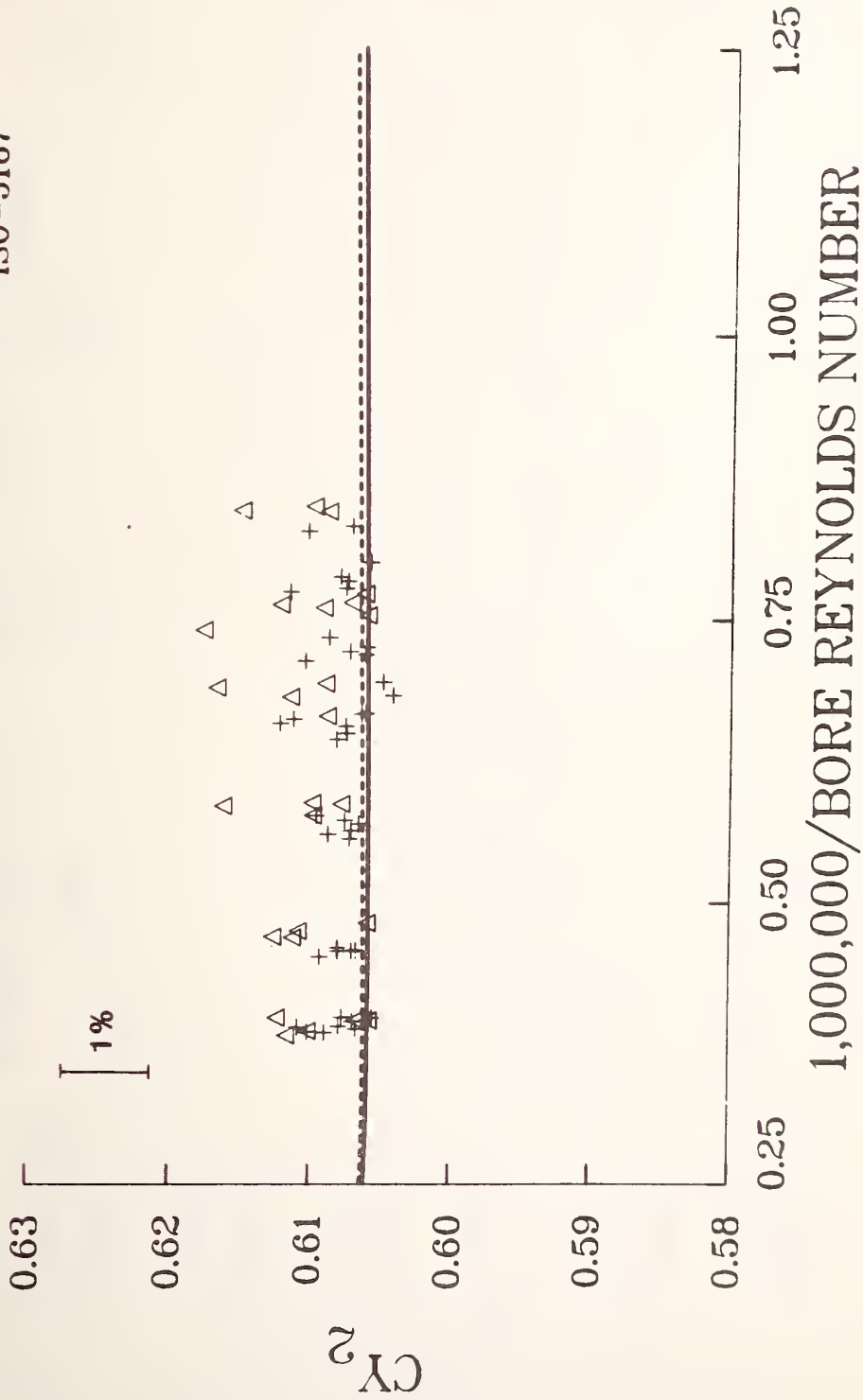

Figure 7(d). Results from the 4 inch meter with the 2-5/8 inch orifice plate.

+ SET A  
 Δ SET B  
 — ANSI/API 2530  
 - - - - ISO-5167

$$\beta = 0.75$$

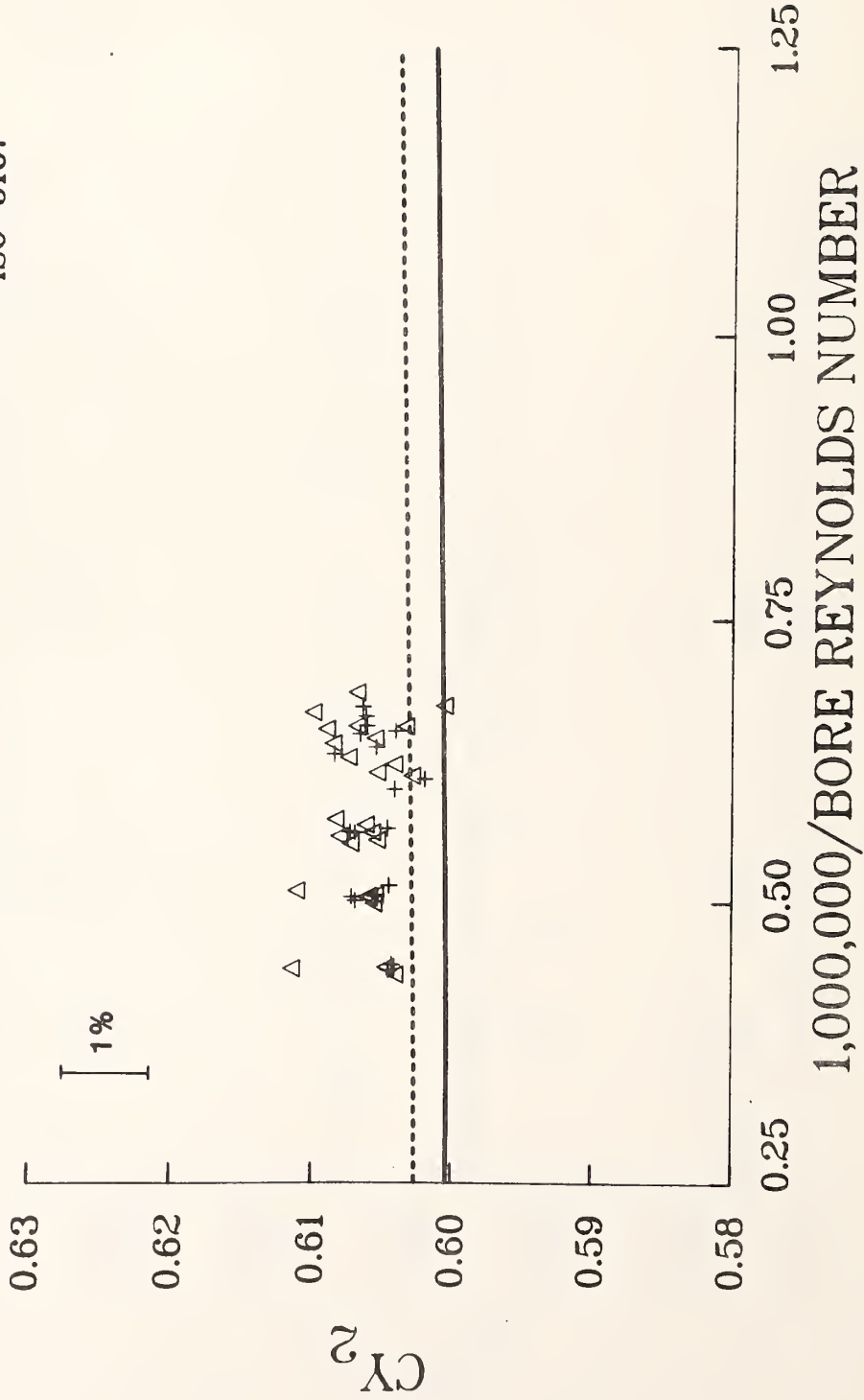

Figure 7(e). Results from the 4 inch meter with the 3 inch orifice plate.



+ SET A  
 Δ SET B  
 — ANSI/API 2530  
 - - - - ISO-5167

$\beta = 0.21$

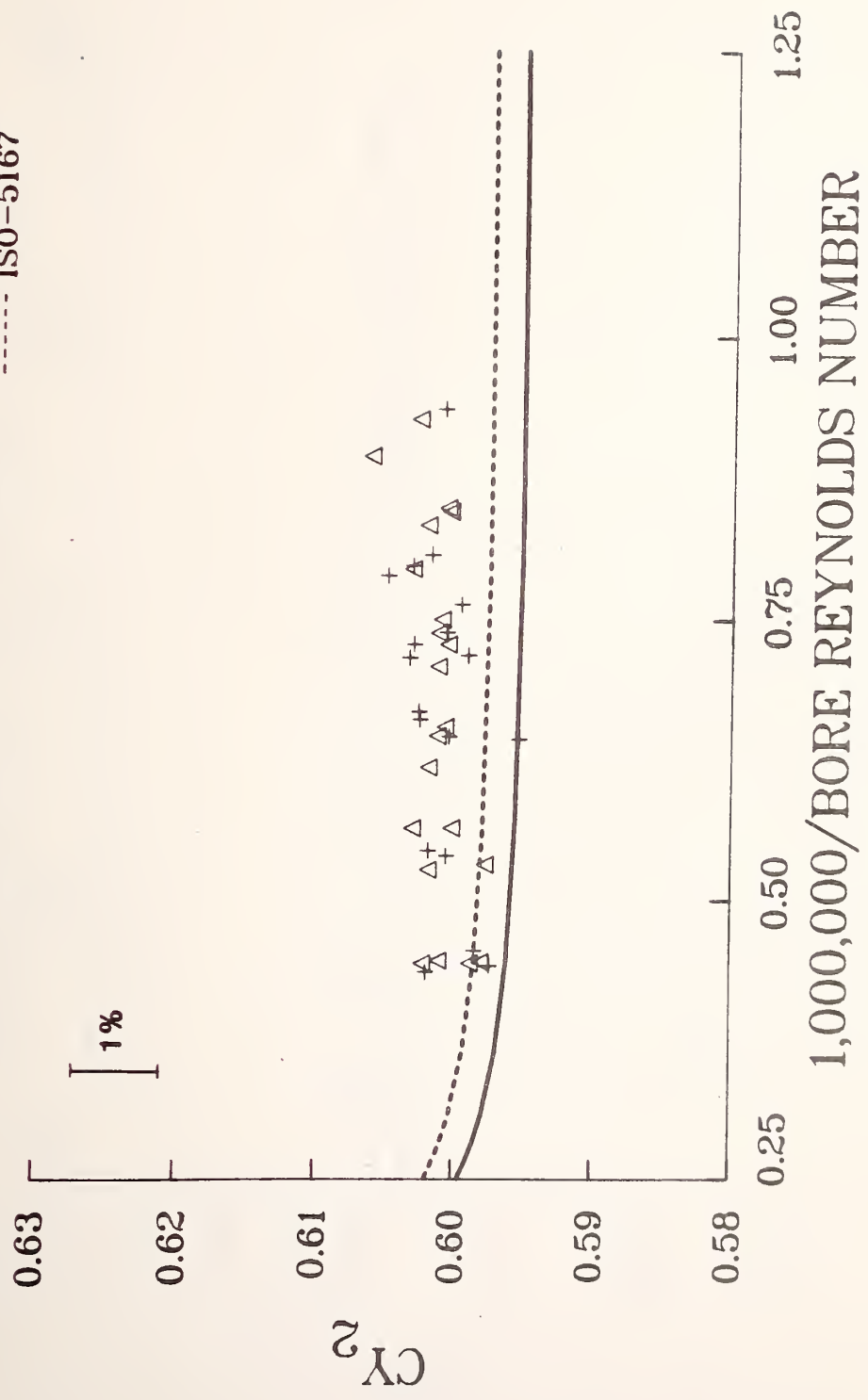

Figure 8(a). Results from the 6 inch meter with the 1-1/4 inch orifice plate.

+ SET A  
 Δ SET B  
 — ANSI/API 2530  
 - - - - ISO-5167

$$\beta = 0.37$$

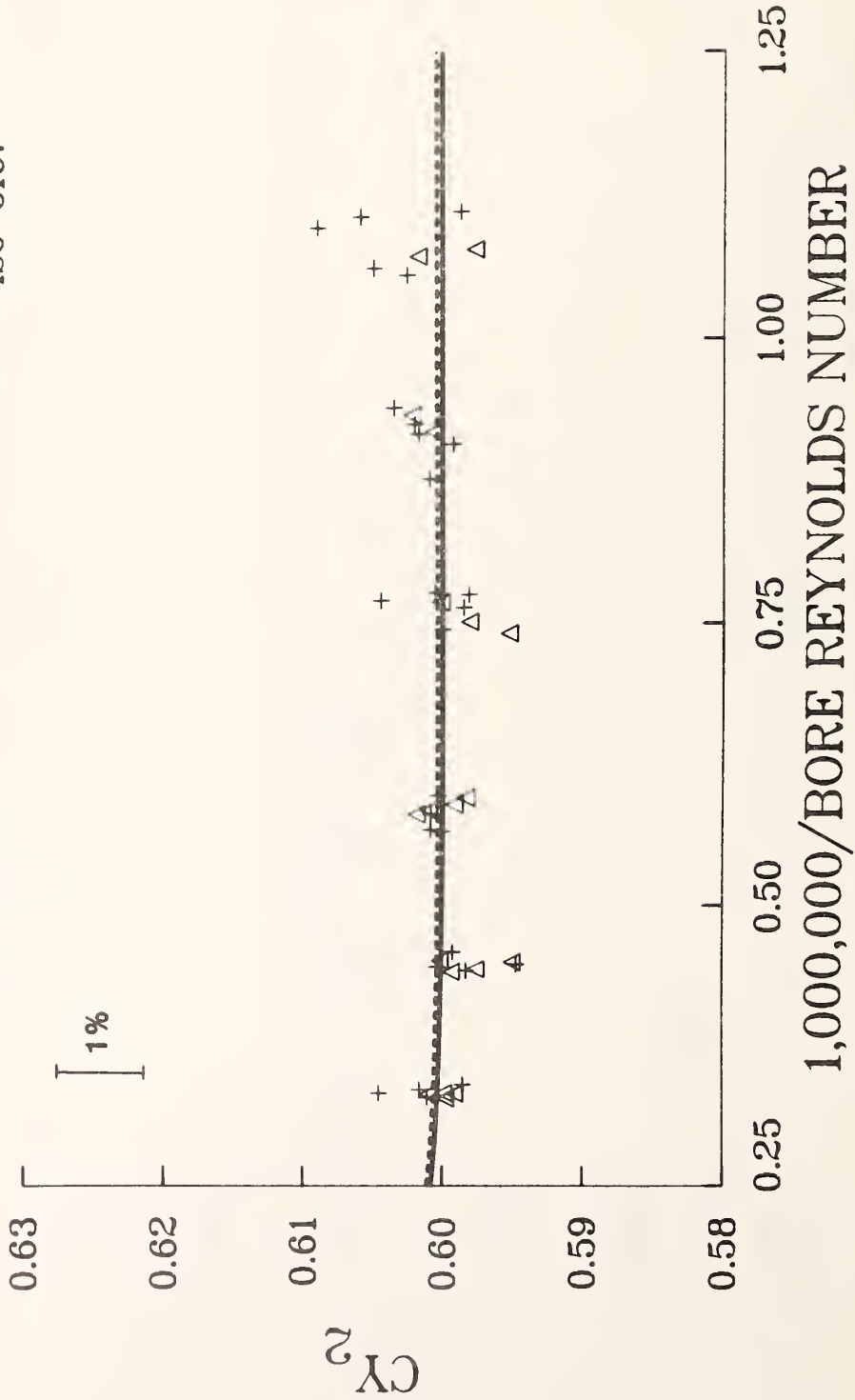

Figure 8(b). Results from the 6 inch meter with the 2-1/4 inch orifice plate.

+ SET A  
 Δ SET B  
 — ANSI/API 2530  
 - - - - ISO-5167

$$\beta = 0.49$$

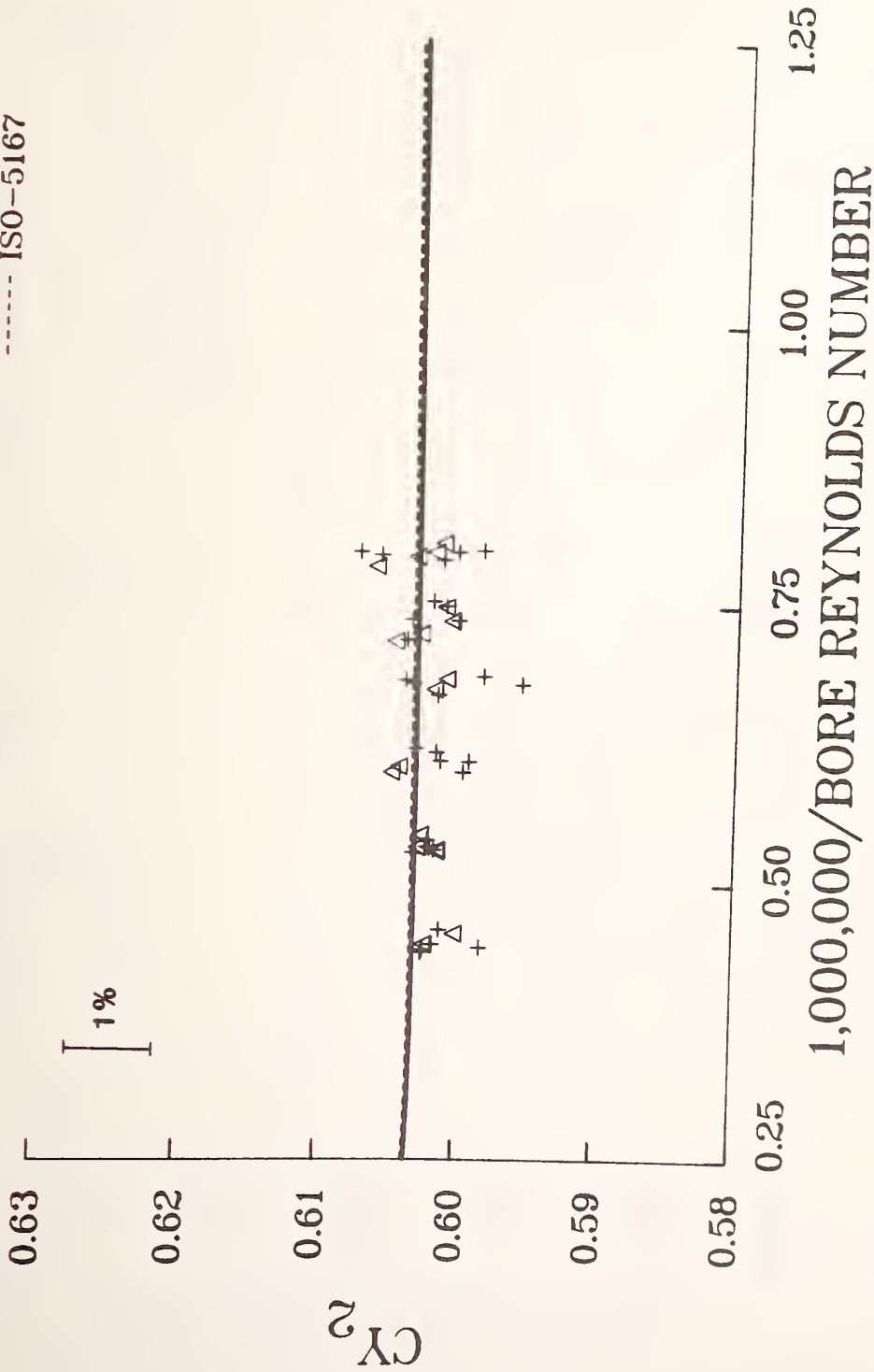

Figure 8(c). Results from the 6 inch meter with the 3 inch orifice plate.

+ SET A  
 Δ SET B  
 — ANSI/API 2530  
 - - - - - ISO-5167

$$\beta = 0.58$$

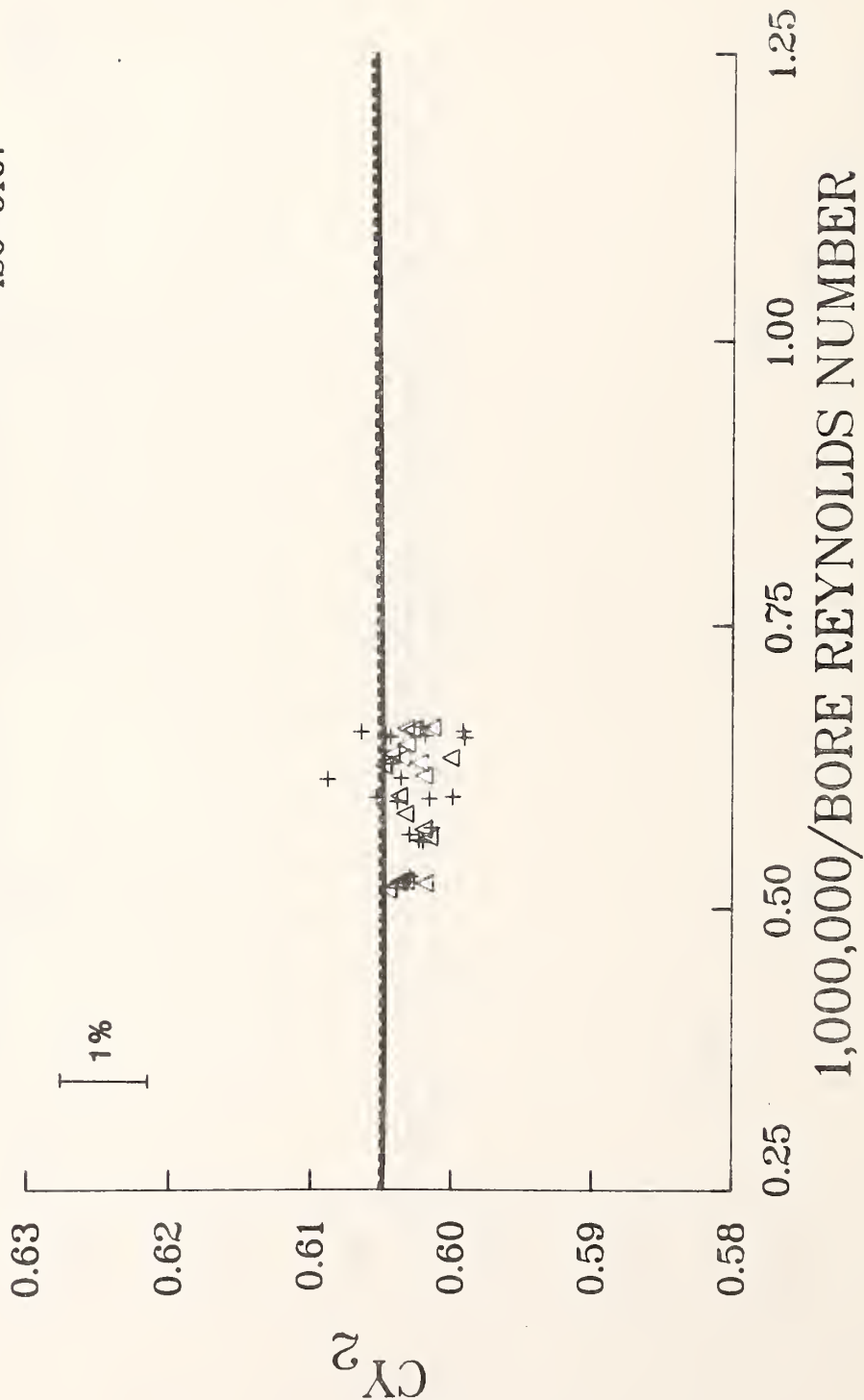

Figure 8(d). Results from the 6 inch meter with the 3-1/2 inch orifice plate.

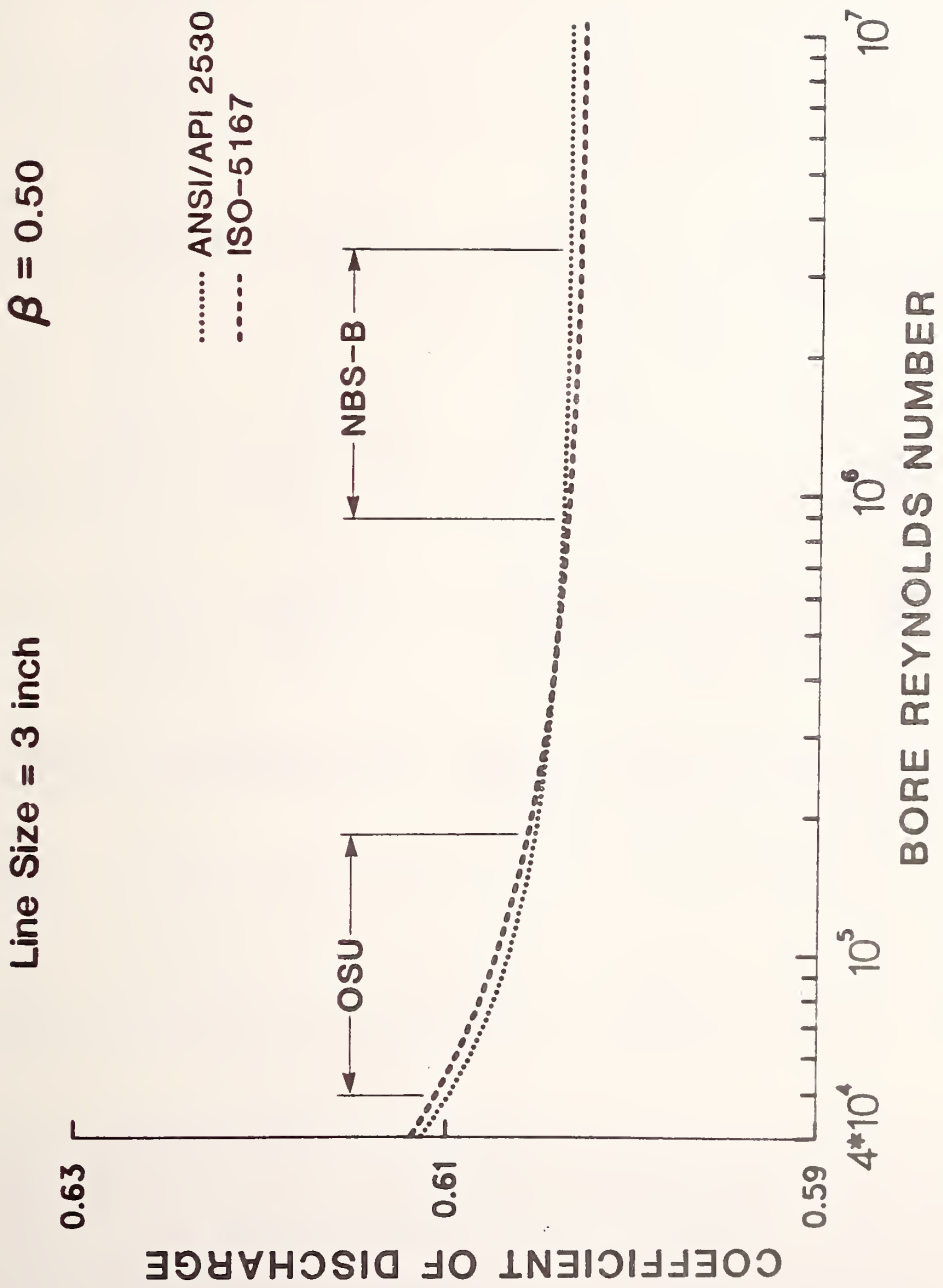

Figure 9 Plot showing Reynolds number ranges for original Ohio State water data [13] and data from this work.

Table 2(a). Test Meter Identification and Physical Measurements  
Nominal 2 Inch AGA/API Orifice Meter (SI Units).

Test Identification	Test Configuration	Run Diameter (cm)	Orifice Diameter (cm)	Beta Ratio
BFE1-4A-072981-[9]	1981-C	5.2520	2.8555	0.5437
BFE1-4A-050582-[9]	1981-D	5.2520	2.8555	0.5437
BFE1-4B-050682-[8]	1981-D	5.2520	2.8565	0.5439
BFE2-4A-011282-[5]	1981-D	5.2598	2.8555	0.5429
BFE2-4A-011482-[1]	1981-D	5.2598	2.8555	0.5429
BFE2-4A-011582-[9]	1981-D	5.2598	2.8555	0.5429
BFE2-4B-011482-[8]	1981-D	5.2598	2.8565	0.5431
BFE1-5A-073081-[9]	1981-C	5.2520	3.4917	0.6648
BFE1-5A-050682-[9]	1981-D	5.2520	3.4917	0.6648
BFE1-5B-111881-[9]	1981-D	5.2520	3.4915	0.6648
BFE1-5B-050582-[9]	1981-D	5.2520	3.4915	0.6648
BFE2-5A-011382-[9]	1981-D	5.2598	3.4917	0.6639
BFE2-5B-011382-[9]	1981-D	5.2598	3.4915	0.6638
BFE2-5B-011582-[9]	1981-D	5.2598	3.4915	0.6638
BFE1-6A-072981-[8]	1981-C	5.2520	3.8108	0.7256
BFE1-6A-073181-[9]	1981-C	5.2520	3.8108	0.7256
BFE1-6A-111881-[7]	1981-D	5.2520	3.8108	0.7256
BFE1-6B-073081-[9]	1981-C	5.2520	3.8105	0.7255
BFE1-6B-073181-[9]	1981-C	5.2520	3.8105	0.7255

Note: Test Identification bracket gives number of tests run with this geometry. A total of 154 tests were run on the nominal 2 inch run size.

Table 2(b). Test Number, Measured and Calculated Quantities  
Nominal 2 Inch AGA/API Orifice Meter (SI Units).

Test Identification	Test Draft (kg)	Test Draft Time (s)	Press. Note 1 (kPa)	Temp. Note 2 (K)	Diff. Press. Note 3 (kPa)	Data Samples N	Mass Flow Rate (kg/s)	Orifice Meter Density (kg/m <sup>3</sup> )	CY <sub>1</sub>	KY <sub>2</sub>	Orifice Bore R <sub>d</sub>
BFE1-4A-072981-1	156.13	272.39	4150.4	292.03	20.394	117	0.5732	48.188	0.6101	0.6386	1.3934E+06
BFE1-4A-072981-2	156.34	234.92	4117.1	291.81	27.745	101	0.6655	47.842	0.6094	0.6380	1.6193E+06
BFE1-4A-072981-3	155.87	208.99	4101.0	291.55	34.764	89	0.7458	47.700	0.6110	0.6396	1.8161E+06
BFE1-4A-072981-4	155.58	174.69	4082.3	291.38	49.748	75	0.8906	47.513	0.6112	0.6397	2.1702E+06
BFE1-4A-072981-5	156.18	235.79	4117.6	291.82	27.406	101	0.6623	47.844	0.6103	0.6389	1.6116E+06
BFE1-4A-072981-6	155.70	172.49	4066.7	291.22	51.665	74	0.9026	47.359	0.6088	0.6373	2.2007E+06
BFE1-4A-072981-7	156.29	278.15	4122.4	291.93	19.664	119	0.5619	47.880	0.6111	0.6396	1.3667E+06
BFE1-4A-072981-8	156.29	252.53	4114.4	291.99	24.003	108	0.6189	47.776	0.6097	0.6383	1.5053E+06
BFE1-4A-072981-9	156.36	318.20	4126.6	292.09	15.051	136	0.4914	47.900	0.6109	0.6395	1.1947E+06
BFE1-4A-050582-1	177.39	194.06	4132.5	290.21	50.942	83	0.9141	48.313	0.6148	0.6435	2.2323E+06
BFE1-4A-050582-2	153.00	277.72	4148.2	290.22	18.489	119	0.5509	48.494	0.6139	0.6426	1.3451E+06
BFE1-4A-050582-3	152.55	172.27	4101.6	289.95	48.198	74	0.8855	47.998	0.6143	0.6430	2.1646E+06
BFE1-4A-050582-4	153.13	288.09	4140.6	290.18	17.280	123	0.5315	48.411	0.6133	0.6420	1.2980E+06
BFE1-4A-050582-5	152.67	193.52	4132.5	289.84	38.251	83	0.7889	48.381	0.6119	0.6405	1.9282E+06
BFE1-4A-050582-6	152.99	247.04	4123.1	290.11	23.631	106	0.6193	48.220	0.6121	0.6407	1.5128E+06
BFE1-4A-050582-7	152.81	206.76	4106.9	290.12	34.052	88	0.7391	48.028	0.6097	0.6383	1.8057E+06
BFE1-4A-050582-8	152.99	233.53	4109.1	289.93	26.758	100	0.6551	48.091	0.6097	0.6383	1.6013E+06
BFE1-4A-050582-9	152.64	288.79	4133.7	290.13	17.098	123	0.5286	48.341	0.6135	0.6422	1.2909E+06
BFE1-4B-050682-1	179.74	336.41	4143.1	289.67	17.208	144	0.5343	48.537	0.6164	0.6453	1.3058E+06
BFE1-4B-050682-2	179.52	232.16	4169.2	290.00	35.865	99	0.7733	48.781	0.6163	0.6452	1.8878E+06
BFE1-4B-050682-3	180.09	320.14	4182.8	289.89	18.976	137	0.5625	48.961	0.6153	0.6442	1.3734E+06
BFE1-4B-050682-4	179.72	197.29	4119.3	290.04	50.468	84	0.9110	48.189	0.6158	0.6446	2.2250E+06
BFE1-4B-050682-5	179.97	303.46	4143.3	290.15	21.269	130	0.5931	48.449	0.6160	0.6448	1.4477E+06
BFE1-4B-050682-6	180.08	238.57	4104.2	289.76	34.703	102	0.7548	48.062	0.6162	0.6451	1.8452E+06
BFE1-4B-050682-7	180.19	291.62	4104.8	289.96	23.342	125	0.6179	48.034	0.6152	0.6440	1.5097E+06
BFE1-4B-050682-8	180.27	278.03	4088.7	289.71	25.660	119	0.6484	47.889	0.6172	0.6461	1.5855E+06
BFE2-4A-011282-1	154.36	168.43	4049.8	289.65	52.434	72	0.9165	47.444	0.6132	0.6417	2.2432E+06
BFE2-4A-011282-2	142.15	264.80	4126.1	289.69	17.664	113	0.5368	48.334	0.6135	0.6420	1.3126E+06
BFE2-4A-011282-3	141.71	161.27	4030.2	289.86	49.003	69	0.8787	47.176	0.6099	0.6382	2.1501E+06
BFE2-4A-011282-4	126.94	233.46	4074.6	289.61	18.294	100	0.5437	47.743	0.6141	0.6427	1.3306E+06
BFE2-4A-011282-5	137.01	186.00	4040.1	289.40	34.097	80	0.7366	47.375	0.6117	0.6401	1.8043E+06
BFE2-4A-011482-1	165.45	310.85	4067.3	290.53	17.706	133	0.5322	47.489	0.6127	0.6411	1.2997E+06

Table 2(b) (cont.). Test Number, Measured and Calculated Quantities  
Nominal 2 Inch AGA/API Orifice Meter (SI Units).

Test Identification	Test Draft (kg)	Test Draft Time (s)	Press. Note 1 (kPa)	Temp. Note 2 (K)	Diff. Press. Note 3 (kPa)	Data Samples N	Mass Flow Rate (kg/s)	Orifice Meter Density (kg/m <sup>3</sup> )	CY <sub>2</sub>	KY <sub>2</sub>	Orifice Bore Rd
BFE2-4A-011582-1	165.84	303.63	4147.9	290.39	18.767	130	0.5462	48.460	0.6045	0.6326	1.3329E+06
BFE2-4A-011582-2	165.94	216.08	4106.3	290.18	36.441	93	0.7679	48.011	0.6127	0.6412	1.8760E+06
BFE2-4A-011582-3	166.09	285.33	4085.5	289.86	21.511	122	0.5821	47.824	0.6058	-0.6339	1.4234E+06
BFE2-4A-011582-4	166.30	300.64	4088.4	289.85	19.187	129	0.5531	47.862	0.6093	0.6376	1.3527E+06
BFE2-4A-011582-5	165.94	252.35	4091.2	290.02	27.128	108	0.6576	47.862	0.6095	0.6378	1.6073E+06
BFE2-4A-011582-6	166.11	226.98	4084.6	289.76	33.791	97	0.7318	47.834	0.6075	0.6358	1.7901E+06
BFE2-4A-011582-7	165.79	188.18	4057.3	289.95	49.162	81	0.8810	47.478	0.6086	0.6369	2.1547E+06
BFE2-4A-011582-8	166.33	274.28	4099.1	289.99	22.952	117	0.6064	47.960	0.6100	0.6384	1.4822E+06
BFE2-4A-011582-9	166.21	323.05	4122.6	289.67	16.528	138	0.5145	48.296	0.6078	0.6361	1.2582E+06
BFE2-4B-011482-1	165.80	304.77	4115.6	290.97	17.963	131	0.5440	47.975	0.6182	0.6470	1.3259E+06
BFE2-4B-011482-2	165.61	225.18	4057.2	291.04	34.140	97	0.7354	47.281	0.6104	0.6388	1.7933E+06
BFE2-4B-011482-4	165.43	188.84	4051.3	290.72	48.479	81	0.8760	47.269	0.6102	0.6386	2.1379E+06
BFE2-4B-011482-5	165.81	285.37	4104.8	290.79	21.036	122	0.5810	47.882	0.6106	0.6390	1.4169E+06
BFE2-4B-011482-6	165.80	230.64	4075.4	290.71	32.690	99	0.7189	47.552	0.6080	0.6363	1.7540E+06
BFE2-4B-011482-7	165.95	274.06	4090.2	290.88	23.048	117	0.6055	47.694	0.6090	0.6374	1.4766E+06
BFE2-4B-011482-8	165.82	250.06	4078.3	290.72	27.678	107	0.6631	47.585	0.6093	0.6377	1.6179E+06
BFE2-4B-011482-9	165.72	320.53	4110.1	290.77	16.465	137	0.5170	47.948	0.6138	0.6424	1.2607E+06
BFE1-5A-073081-1	172.13	126.02	4050.0	291.20	45.957	54	1.3659	47.167	0.6146	0.6852	2.7240E+06
BFE1-5A-073081-2	172.57	211.85	4131.0	291.51	16.029	91	0.8146	48.057	0.6149	0.6855	1.6217E+06
BFE1-5A-073081-3	172.38	127.15	4052.7	291.19	44.810	55	1.3558	47.202	0.6175	0.6885	2.7037E+06
BFE1-5A-073081-4	172.50	211.08	4127.5	291.64	16.199	90	0.8172	47.993	0.6140	0.6845	1.6266E+06
BFE1-5A-073081-5	172.73	271.29	4156.1	291.73	9.789	116	0.6367	48.309	0.6135	0.6839	1.2666E+06
BFE1-5A-073081-6	172.43	157.42	4059.2	291.25	29.298	67	1.0954	47.266	0.6166	0.6874	2.1839E+06
BFE1-5A-073081-7	172.43	174.07	4057.4	291.53	24.285	74	0.9906	47.195	0.6130	0.6833	1.9738E+06
BFE1-5A-073081-8	173.08	282.74	4164.6	291.90	9.021	121	0.6122	48.378	0.6140	0.6845	1.2172E+06
BFE1-5A-073081-9	141.88	276.57	4171.1	291.89	6.313	118	0.5130	48.454	0.6151	0.6857	1.0199E+06
BFE1-5A-050682-1	179.61	299.84	4169.5	289.14	8.371	129	0.5990	48.946	0.6202	0.6914	1.1988E+06
BFE1-5A-050682-2	179.26	159.66	4049.7	289.30	30.478	69	1.1227	47.505	0.6182	0.6891	2.2491E+06
BFE1-5A-050682-3	179.58	263.53	4088.2	289.54	11.110	113	0.6814	47.914	0.6189	0.6899	1.3637E+06
BFE1-5A-050682-4	179.45	124.70	3961.1	288.85	51.147	53	1.4391	46.544	0.6179	0.6889	2.8890E+06
BFE1-5A-050682-5	180.12	309.67	4071.2	289.63	8.140	132	0.5817	47.699	0.6186	0.6896	1.1640E+06
BFE1-5A-050682-6	179.56	162.57	4086.4	289.57	29.443	70	1.1045	47.889	0.6163	0.6870	2.2102E+06
BFE1-5A-050682-7	179.70	126.11	4041.0	289.62	49.364	54	1.4250	47.346	0.6175	0.6884	2.8527E+06
BFE1-5A-050682-8	180.11	208.19	4124.2	289.62	17.978	89	0.8651	48.324	0.6149	0.6855	1.7302E+06
BFE1-5A-050682-9	180.25	342.05	4153.7	289.53	6.586	146	0.5270	48.688	0.6167	0.6875	1.0538E+06



Table 2(b) (cont.). Test Number, Measured and Calculated Quantities  
Nominal 2 Inch AGA/API Orifice Meter (SI Units).

Test Identification	Test Draft (kg)	Test Draft Time (s)	Press. Note 1 (kPa)	Temp. Note 2 (K)	Diff. Press. Note 3 (kPa)	Data Samples N	Mass Flow Rate (kg/s)	Orifice Meter Density (kg/m <sup>3</sup> )	CY <sub>2</sub>	KY <sub>2</sub>	Orifice Bore R <sub>d</sub>
BFE1-5B-111881-1	174.87	119.91	4004.1	289.38	52.457	51	1.4583	46.955	0.6157	0.6864	2.9227E+06
BFE1-5B-111881-2	174.73	159.44	4034.9	290.41	29.606	68	1.0959	47.132	0.6147	0.6853	2.1902E+06
BFE1-5B-111881-3	148.48	221.64	4012.2	290.58	11.160	95	0.6699	46.835	0.6141	0.6846	1.3386E+06
BFE1-5B-111881-4	143.83	243.02	3985.9	290.73	8.771	104	0.5918	46.503	0.6143	0.6848	1.1826E+06
BFE1-5B-111881-5	171.82	199.55	4121.7	290.22	17.769	85	0.8611	48.184	0.6166	0.6874	1.7198E+06
BFE1-5B-111881-6	171.48	232.19	4021.5	289.63	27.190	70	1.0508	47.114	0.6152	0.6858	2.1042E+06
BFE1-5B-111881-7	146.90	163.60	4121.5	290.06	9.545	99	0.6315	48.212	0.6170	0.6878	1.2619E+06
BFE1-5B-111881-8	160.71	113.70	3965.8	289.67	49.734	49	1.4135	46.454	0.6162	0.6869	2.8322E+06
BFE1-5B-111881-9	146.51	268.25	4123.6	289.85	7.198	115	0.5462	48.273	0.6142	0.6846	1.0918E+06
BFE1-5B-050582-1	179.76	122.96	4011.6	289.44	52.805	53	1.4619	47.033	0.6147	0.6852	2.9292E+06
BFE1-5B-050582-2	179.49	167.38	4060.0	289.66	28.244	72	1.0724	47.563	0.6130	0.6834	2.1463E+06
BFE1-5B-050582-3	179.93	257.89	4112.8	290.33	11.679	110	0.6977	48.060	0.6171	0.6880	1.3933E+06
BFE1-5B-050582-4	179.71	291.60	4114.2	290.33	9.161	124	0.6163	48.076	0.6154	0.6861	1.2307E+06
BFE1-5B-050582-5	179.64	209.97	4073.8	289.89	17.789	90	0.8555	47.683	0.6155	0.6862	1.7111E+06
BFE1-5B-050582-6	179.42	165.76	4029.0	289.85	28.950	71	1.0824	47.164	0.6138	0.6842	2.1662E+06
BFE1-5B-050582-7	179.81	300.91	4076.9	290.14	8.646	128	0.5976	47.673	0.6168	0.6876	1.1944E+06
BFE1-5B-050582-8	179.13	127.07	3949.8	289.29	49.858	54	1.4097	46.332	0.6146	0.6851	2.8276E+06
BFE1-5B-050582-9	179.77	333.15	4068.1	289.89	7.099	142	0.5396	47.615	0.6153	0.6859	1.0793E+06
BFE2-5A-011382-1	162.43	276.34	4142.3	290.45	8.358	118	0.5878	48.382	0.6129	0.6828	1.1730E+06
BFE2-5A-011382-2	162.07	145.42	4085.9	290.17	30.777	62	1.1145	47.774	0.6093	0.6788	2.2271E+06
BFE2-5A-011382-3	162.67	233.74	4118.6	290.37	11.744	100	0.6959	48.120	0.6138	0.6838	1.3895E+06
BFE2-5A-011382-4	162.24	115.36	3976.4	290.13	50.065	49	1.4064	46.497	0.6111	0.6808	2.8143E+06
BFE2-5A-011382-5	162.53	274.45	4095.7	290.26	8.597	118	0.5922	47.871	0.6121	0.6819	1.1830E+06
BFE2-5A-011382-6	162.19	151.31	4018.8	290.41	28.929	65	1.0719	46.944	0.6098	0.6793	2.1424E+06
BFE2-5A-011382-7	162.23	116.12	3980.7	290.07	49.424	50	1.3971	46.557	0.6106	0.6802	2.7959E+06
BFE2-5A-011382-8	161.57	196.11	4081.1	290.38	16.754	84	0.8239	47.679	0.6111	0.6808	1.6456E+06
BFE2-5A-011382-9	162.68	307.24	4086.4	290.13	6.861	131	0.5295	47.786	0.6134	0.6833	1.0582E+06
BFE2-5B-011382-1	163.23	114.15	4006.4	290.97	51.754	49	1.4299	46.700	0.6099	0.6794	2.8549E+06
BFE2-5B-011382-2	163.08	150.68	4061.1	290.78	29.277	65	1.0823	47.372	0.6094	0.6788	2.1604E+06
BFE2-5B-011382-3	174.83	261.37	4098.3	290.87	10.942	112	0.6689	47.790	0.6134	0.6833	1.3343E+06
BFE2-5B-011382-4	149.07	253.97	4097.9	290.70	8.430	109	0.5870	47.817	0.6132	0.6831	1.1714E+06
BFE2-5B-011382-5	162.34	193.48	4069.0	290.85	17.515	83	0.8390	47.453	0.6103	0.6798	1.6744E+06
BFE2-5B-011382-6	161.66	148.79	4030.3	290.40	29.622	64	1.0865	47.080	0.6101	0.6796	2.1715E+06
BFE2-5B-011382-7	163.37	272.01	4065.4	290.55	8.846	116	0.6006	47.465	0.6147	0.6848	1.1995E+06
BFE2-5B-011382-8	161.93	113.98	3937.0	290.11	51.539	49	1.4207	46.038	0.6115	0.6812	2.8446E+06
BFE2-5B-011382-9	162.95	322.41	4074.3	290.72	6.301	138	0.5054	47.538	0.6125	0.6823	1.0088E+06

Table 2(b) (cont.). Test Number, Measured and Calculated Quantities  
Nominal 2 Inch AGA/API Orifice Meter (SI Units).

Test Identification	Test Draft (kg)	Test Draft Time (s)	Press. Note 1 (kPa)	Temp. Note 2 (K)	Diff. Press. Note 3 (kPa)	Data Samples N	Mass Flow Rate (kg/s)	Orifice Meter Density (kg/m <sup>3</sup> )	CY <sub>2</sub>	KY <sub>2</sub>	Orifice Bore R <sub>d</sub>
BFE2-5B-011582-1	173.59	162.00	4078.3	290.17	28.424	69	1.0715	47.684	0.6103	0.6799	2.1416E+06
BFE2-5B-011582-2	184.22	303.80	4150.8	290.25	8.968	130	0.6064	48.520	0.6097	0.6792	1.2107E+06
BFE2-5B-011582-3	183.83	213.90	4108.5	290.18	18.096	92	0.8594	48.037	0.6112	0.6809	1.7170E+06
BFE2-5B-011582-4	183.62	170.65	4049.4	290.04	28.762	73	1.0760	47.368	0.6112	0.6809	2.1519E+06
BFE2-5B-011582-5	184.07	319.39	4129.0	290.17	8.124	137	0.5763	48.279	0.6103	0.6799	1.1512E+06
BFE2-5B-011582-6	183.88	258.79	4113.9	290.29	12.423	111	0.7105	48.081	0.6097	0.6792	1.4191E+06
BFE2-5B-011582-7	183.72	218.88	4099.8	290.05	17.317	94	0.8394	47.959	0.6108	0.6804	1.6777E+06
BFE2-5B-011582-8	183.69	128.96	3975.7	290.30	51.342	55	1.4244	46.459	0.6115	0.6812	2.8494E+06
BFE2-5B-011582-9	184.19	347.30	4119.8	290.31	6.822	149	0.5303	48.145	0.6138	0.6837	1.0591E+06
BFEL-6A-072981-1	172.46	279.02	4211.0	292.36	5.763	119	0.6181	48.831	0.6143	0.7226	1.1242E+06
BFEL-6A-072981-2	172.41	93.10	3987.0	291.15	54.298	40	1.8519	46.440	0.6147	0.7231	3.3868E+06
BFEL-6A-072981-3	172.38	219.15	4141.2	292.24	9.451	94	0.7866	48.043	0.6154	0.7239	1.4323E+06
BFEL-6A-072981-4	172.21	96.59	3957.3	291.22	51.023	41	1.7829	46.082	0.6129	0.7209	3.2612E+06
BFEL-6A-072981-5	172.25	130.29	3988.2	291.44	27.734	56	1.3220	46.405	0.6143	0.7225	2.4161E+06
BFEL-6A-072981-6	172.30	177.19	4030.7	291.79	15.006	76	0.9724	46.837	0.6115	0.7192	1.7748E+06
BFEL-6A-072981-7	172.60	290.97	4162.2	291.95	5.368	124	0.5932	48.339	0.6140	0.7222	1.0806E+06
BFEL-6A-072981-8	172.60	170.82	4085.8	291.60	15.686	73	1.0104	47.512	0.6170	0.7257	1.8438E+06
BFEL-6A-073181-1	174.85	97.07	3939.5	290.10	51.236	42	1.8013	46.069	0.6181	0.7270	3.3044E+06
BFEL-6A-073181-2	175.34	286.63	4128.7	290.78	5.644	123	0.6117	48.163	0.6187	0.7278	1.1179E+06
BFEL-6A-073181-3	174.74	128.79	4028.5	290.26	28.295	55	1.3568	47.085	0.6197	0.7289	2.4854E+06
BFEL-6A-073181-4	175.43	289.40	4145.0	290.60	5.617	124	0.6062	48.386	0.6132	0.7213	1.1080E+06
BFEL-6A-073181-5	174.70	96.70	3953.2	289.87	51.450	42	1.8066	46.269	0.6172	0.7260	3.3154E+06
BFEL-6A-073181-6	174.98	215.40	4116.2	290.80	10.137	92	0.8124	48.014	0.6139	0.7221	1.4847E+06
BFEL-6A-073181-7	174.64	169.28	4102.2	290.35	16.361	72	1.0317	47.933	0.6142	0.7224	1.8878E+06
BFEL-6A-073181-8	174.73	127.76	4031.4	290.05	29.130	55	1.3676	47.155	0.6152	0.7236	2.5065E+06
BFEL-6A-073181-9	149.93	279.89	4157.1	290.56	4.354	120	0.5357	48.537	0.6145	0.7228	9.7906E+05
BFEL-6A-111881-1	170.72	96.28	3942.2	290.88	50.598	41	1.7732	45.964	0.6129	0.7209	3.2467E+06
BFEL-6A-111881-2	173.00	270.77	4113.7	291.41	6.272	116	0.6389	47.873	0.6148	0.7231	1.1660E+06
BFEL-6A-111881-3	172.66	97.79	3905.0	290.77	50.042	42	1.7656	45.548	0.6165	0.7251	3.2351E+06
BFEL-6A-111881-4	172.80	285.58	4087.1	291.08	5.639	122	0.6051	47.622	0.6157	0.7242	1.1055E+06
BFEL-6A-111881-5	172.57	131.56	3980.5	290.71	27.198	56	1.3117	46.443	0.6152	0.7236	2.4016E+06
BFEL-6A-111881-6	172.99	230.10	4062.6	291.03	8.720	98	0.7518	47.345	0.6169	0.7256	1.3741E+06
BFEL-6A-111881-7	172.62	130.89	3976.8	289.90	27.140	56	1.3188	46.543	0.6186	0.7276	2.4194E+06

Table 2(b) (cont.). Test Number, Measured and Calculated Quantities  
Nominal 2 Inch AGA/API Orifice Meter (SI Units).

Test Identification	Test Draft (kg)	Test Draft Time (s)	Press. Note 1 (kPa)	Temp. Note 2 (K)	Diff. Press. Note 3 (kPa)	Data Samples N	Mass Flow Rate (kg/s)	Orifice Meter Density (kg/m <sup>3</sup> )	CY <sub>2</sub>	KY <sub>2</sub>	Orifice Bore Rd
BFEL-6B-073081-1	158.13	115.06	4091.9	290.88	29.132	49	1.3743	47.715	0.6146	0.7229	2.5121E+06
BFEL-6B-073081-2	158.65	210.12	4101.3	291.33	8.720	90	0.7550	47.743	0.6173	0.7260	1.3785E+06
BFEL-6B-073081-3	158.44	117.26	4026.4	290.36	28.875	50	1.3512	47.041	0.6113	0.7189	2.4748E+06
BFEL-6B-073081-4	158.62	207.53	4094.2	291.10	9.019	89	0.7643	47.701	0.6145	0.7227	1.3963E+06
BFEL-6B-073081-5	158.06	248.10	4109.9	291.08	6.256	106	0.6371	47.888	0.6138	0.7219	1.1637E+06
BFEL-6B-073081-6	168.37	93.67	3945.7	289.87	51.090	40	1.7975	46.183	0.6170	0.7257	3.2993E+06
BFEL-6B-073081-7	168.68	168.03	4059.0	290.38	15.809	72	1.0039	47.420	0.6113	0.7190	1.8379E+06
BFEL-6B-073081-8	168.64	93.53	3946.2	289.54	51.376	40	1.8030	46.246	0.6168	0.7254	3.3121E+06
BFEL-6B-073081-9	149.35	267.96	4147.3	290.92	4.748	115	0.5574	48.356	0.6135	0.7216	1.0181E+06
BFEL-6B-073181-1	180.63	174.11	4134.8	290.67	16.642	75	1.0375	48.255	0.6104	0.7180	1.8964E+06
BFEL-6B-073181-2	182.03	132.58	4076.1	290.34	28.922	57	1.3730	47.627	0.6168	0.7255	2.5134E+06
BFEL-6B-073181-3	179.80	98.66	3983.7	289.97	52.013	42	1.8224	46.611	0.6171	0.7258	3.3427E+06
BFEL-6B-073181-4	178.80	279.01	4185.3	290.93	6.274	119	0.6408	48.798	0.6108	0.7184	1.1700E+06
BFEL-6B-073181-5	180.31	133.30	4067.6	290.33	28.273	57	1.3526	47.529	0.6152	0.7236	2.4764E+06
BFEL-6B-073181-6	182.09	273.55	4184.1	290.67	6.724	117	0.6656	48.831	0.6126	0.7205	1.2160E+06
BFEL-6B-073181-7	181.45	227.60	4174.0	290.57	9.625	97	0.7972	48.732	0.6138	0.7219	1.4569E+06
BFEL-6B-073181-8	180.27	100.44	3995.5	289.36	50.586	43	1.7948	46.857	0.6147	0.7229	3.2964E+06
BFEL-6B-073181-9	137.35	241.14	4202.3	290.80	4.849	103	0.5696	49.020	0.6162	0.7247	1.0400E+06

Note 1: Orifice meter pressure measured at the downstream flange tap and calculated as a simple average of N data samples during Draft Time.

Note 2: Flowing gas temperature measured downstream of the meter and calculated as a simple average of N data samples taken during Draft Time.

Note 3: Differential pressure measured between the flange taps and calculated as the square of the average of the square roots of N data samples taken during Draft Time.

Table 3(a). Test Meter Identification and Physical Measurements  
Nominal 3 Inch AGA/API Orifice Meter (SI Units).

Test Identification	Test Configuration	Run Diameter (cm)	Orifice Diameter (cm)	Beta Ratio
BFE3-2A-011982-[8]	1982-A	7.7925	2.8575	0.3667
BFE3-2B-012182-[9]	1982-A	7.7925	2.8572	0.3667
BFE4-2A-070782-[6]	1982-A	7.7922	2.8575	0.3667
BFE4-2B-070782-[4]	1982-A	7.7922	2.8572	0.3667
BFE4-2B-070982-[9]	1982-A	7.7922	2.8572	0.3667
BFE3-3B-012282-[9]	1982-A	7.7925	3.8092	0.4888
BFE4-3A-061981-[9]	1981-B	7.7922	3.8100	0.4890
BFE4-3A-072381-[9]	1981-B	7.7922	3.8100	0.4890
BFE4-3B-061881-[9]	1981-B	7.7922	3.8092	0.4889
BFE4-3B-072281-[9]	1981-B	7.7922	3.8092	0.4889
BFE3-4B-011982-[9]	1982-A	7.7925	4.4445	0.5704
BFE3-4B-012282-[9]	1982-A	7.7925	4.4445	0.5704
BFE4-4A-061981-[9]	1981-B	7.7922	4.4458	0.5705
BFE4-4A-072181-[9]	1981-B	7.7922	4.4458	0.5705
BFE4-4B-070282-[9]	1982-A	7.7922	4.4445	0.5704
BFE3-5A-012082-[8]	1982-A	7.7925	5.0815	0.6521
BFE3-5B-012082-[9]	1982-A	7.7925	5.0795	0.6519
BFE4-5A-070282-[9]	1982-A	7.7922	5.0815	0.6521
BFE4-5B-070882-[10]	1982-A	7.7922	5.0795	0.6519
BFE3-6B-012182-[8]	1982-A	7.7925	5.7140	0.7333
BFE4-6A-061781-[9]	1981-B	7.7922	5.7130	0.7332
BFE4-6A-072281-[9]	1981-B	7.7922	5.7130	0.7332
BFE4-6B-070882-[9]	1982-A	7.7922	5.7140	0.7333

Note: Test Identification bracket gives number of tests run with this geometry. A total of 197 tests were run on the nominal 3 inch run size.

Table 3(b). Test Number, Measured and Calculated Quantities  
Nominal 3 Inch AGA/API Orifice Meter (SI Units).

Test Identification	Test Draft (kg)	Test Draft Time (s)	Press. Note 1 (kPa)	Temp. Note 2 (K)	Diff. Press. Note 3 (kPa)	Data Samples N	Mass Flow Rate (kg/s)	Orifice Meter Density (kg/m <sup>3</sup> )	CY <sub>2</sub>	KY <sub>2</sub>	Orifice Bore Rd
BFE3-2A-011982-1	183.26	258.55	4096.6	291.04	34.416	111	0.7088	47.741	0.6043	0.6098	1.7270E+06
BFE3-2A-011982-2	183.06	216.34	4064.7	290.99	49.100	93	0.8461	47.377	0.6062	0.6118	2.0626E+06
BFE3-2A-011982-3	183.37	315.59	4119.8	290.92	23.007	135	0.5810	48.033	0.6041	0.6096	1.4157E+06
BFE3-2A-011982-4	183.25	215.03	4048.2	291.45	50.708	92	0.8522	47.103	0.6026	0.6081	2.0756E+06
BFE3-2A-011982-5	183.28	286.32	4085.4	291.67	28.356	123	0.6401	47.497	0.6028	0.6083	1.5575E+06
BFE3-2A-011982-6	176.88	250.96	4075.3	291.66	34.507	107	0.7048	47.381	0.6023	0.6079	1.7151E+06
BFE3-2A-011982-7	177.02	300.05	4098.2	291.77	23.912	128	0.5900	47.629	0.6042	0.6098	1.4349E+06
BFE3-2A-011982-8	177.08	276.19	4083.1	291.76	28.548	118	0.6411	47.453	0.6019	0.6075	1.5597E+06
BFE3-2B-012182-1	167.51	274.91	4139.1	285.97	24.697	118	0.6093	49.185	0.6044	0.6099	1.5021E+06
BFE3-2B-012182-2	167.05	246.57	4092.6	285.94	30.824	106	0.6775	48.636	0.6049	0.6104	1.6712E+06
BFE3-2B-012182-3	167.10	236.28	4080.0	285.81	34.252	101	0.7072	48.510	0.5998	0.6052	1.7453E+06
BFE3-2B-012182-4	167.34	296.40	4095.7	286.19	21.486	127	0.5646	48.626	0.6039	0.6094	1.3918E+06
BFE3-2B-012182-5	167.09	193.51	4054.2	287.89	51.431	83	0.8635	47.818	0.6019	0.6074	2.1210E+06
BFE3-2B-012182-6	166.71	260.34	4098.1	288.24	27.950	111	0.6404	48.271	0.6027	0.6083	1.5708E+06
BFE3-2B-012182-7	166.63	295.91	4084.5	288.42	21.767	127	0.5631	48.078	0.6018	0.6073	1.3809E+06
BFE3-2B-012182-8	166.43	194.89	4040.4	288.34	51.248	83	0.8540	47.570	0.5978	0.6033	2.0957E+06
BFE3-2B-012182-9	166.76	325.19	4086.2	288.68	17.844	139	0.5128	48.049	0.6055	0.6110	1.2567E+06
BFE4-2A-070782-1	168.38	228.73	4105.0	288.25	36.856	80	0.7362	48.351	0.6027	0.6082	1.8054E+06
BFE4-2A-070782-2	168.36	196.83	4062.8	288.04	49.594	69	0.8554	47.891	0.6066	0.6122	2.0999E+06
BFE4-2A-070782-3	168.98	324.82	4126.1	288.41	18.404	113	0.5202	48.571	0.6015	0.6070	1.2750E+06
BFE4-2A-070782-4	168.65	198.95	4019.2	288.06	49.965	70	0.8477	47.371	0.6022	0.6077	2.0820E+06
BFE4-2A-070782-5	168.65	249.37	4098.1	288.41	31.499	87	0.6763	48.240	0.5996	0.6051	1.6581E+06
BFE4-2A-070782-6	168.42	228.38	4073.3	288.33	37.462	80	0.7375	47.962	0.6013	0.6068	1.8089E+06
BFE4-2B-070782-1	166.17	280.70	4169.3	288.85	23.394	98	0.5920	48.997	0.6045	0.6100	1.4488E+06
BFE4-2B-070782-2	165.93	261.18	4142.3	288.42	27.336	91	0.6353	48.760	0.6015	0.6070	1.5569E+06
BFE4-2B-070782-3	168.17	221.10	4124.4	288.09	39.387	77	0.7606	48.611	0.6008	0.6063	1.8658E+06
BFE4-2B-070782-4	167.45	295.09	4167.4	288.34	21.860	105	0.5675	49.071	0.5990	0.6045	1.3904E+06
BFE4-2B-070982-2	171.38	287.91	4149.1	288.58	23.728	101	0.5953	48.811	0.6047	0.6102	1.4581E+06
BFE4-2B-070982-3	171.67	258.49	4128.7	288.31	30.076	91	0.6641	48.619	0.6003	0.6058	1.6282E+06
BFE4-2B-070982-4	171.53	240.07	4125.4	288.26	34.623	84	0.7145	48.591	0.6022	0.6077	1.7520E+06
BFE4-2B-070982-5	171.58	344.86	4137.6	288.58	16.799	120	0.4975	48.675	0.6016	0.6071	1.2189E+06
BFE4-2B-070982-6	171.13	199.34	4095.5	287.68	50.240	70	0.8585	48.344	0.6021	0.6076	2.1087E+06
BFE4-2B-070982-7	171.56	257.99	4115.7	288.20	30.055	90	0.6650	48.486	0.6021	0.6077	1.6309E+06
BFE4-2B-070982-8	170.92	322.98	4128.8	288.22	19.085	113	0.5292	48.637	0.6005	0.6060	1.2977E+06
BFE4-2B-070982-9	171.52	202.88	4089.2	287.56	48.824	71	0.8454	48.293	0.6018	0.6073	2.0774E+06
BFE4-2B-070982-10	171.80	311.84	4122.9	288.16	20.629	109	0.5509	48.580	0.6016	0.6072	1.3513E+06

Table 3(b) (cont.). Test Number, Measured and Calculated Quantities  
Nominal 3 Inch AGA/API Orifice Meter (SI Units).

Test Identification	Test Draft (kg)	Test Draft Time (s)	Press. Note 1 (kPa)	Temp. Note 2 (K)	Diff. Press. Note 3 (kPa)	Data Samples N	Mass Flow Rate (kg/s)	Orifice Meter Density (kg/m <sup>3</sup> )	CY <sub>2</sub>	KY <sub>2</sub>	Orifice Bore Rd
BFE3-3B-012282-1	180.77	248.75	4114.5	288.85	10.760	107	0.7267	48.353	0.6072	0.6253	1.3349E+06
BFE3-3B-012282-2	180.38	117.52	3984.3	288.56	49.491	51	1.5348	46.868	0.6073	0.6254	2.8256E+06
BFE3-3B-012282-3	181.41	302.51	4119.8	288.79	7.266	129	0.5997	48.426	0.6094	0.6275	1.1016E+06
BFE3-3B-012282-4	180.62	196.41	4057.6	288.78	17.625	84	0.9196	47.694	0.6044	0.6225	1.6906E+06
BFE3-3B-012282-5	180.55	117.89	3963.2	289.17	49.715	51	1.5315	46.511	0.6069	0.6250	2.8161E+06
BFE3-3B-012282-6	181.03	299.55	4103.4	289.01	7.464	128	0.6043	48.191	0.6073	0.6255	1.1098E+06
BFE3-3B-012282-7	180.94	245.78	4088.0	288.90	11.196	105	0.7362	48.032	0.6050	0.6231	1.3526E+06
BFE3-3B-012282-8	180.71	154.02	4031.1	288.99	28.586	66	1.1733	47.343	0.6078	0.6259	2.1566E+06
BFE3-3B-012282-9	181.31	335.79	4100.1	288.92	5.941	144	0.5399	48.169	0.6084	0.6266	9.9180E+05
BFE4-3A-061981-1	181.40	119.46	4013.8	289.81	48.018	50	1.5185	46.993	0.6088	0.6270	2.7857E+06
BFE4-3A-061981-2	181.16	211.12	4098.1	290.12	15.301	88	0.8581	47.926	0.6036	0.6216	1.5715E+06
BFE4-3A-061981-3	180.90	117.21	4021.1	289.59	49.807	49	1.5439	47.117	0.6068	0.6249	2.8325E+06
BFE4-3A-061981-4	181.14	146.81	4062.0	289.57	31.530	61	1.2339	47.601	0.6066	0.6247	2.2635E+06
BFE4-3A-061981-5	182.43	290.12	4138.8	290.23	8.019	122	0.6288	48.382	0.6082	0.6264	1.1507E+06
BFE4-3A-061981-6	182.01	234.91	4130.4	289.99	12.273	98	0.7748	48.330	0.6060	0.6241	1.4188E+06
BFE4-3A-061981-7	181.05	203.27	4124.7	289.65	16.208	85	0.8907	48.324	0.6062	0.6243	1.6324E+06
BFE4-3A-061981-8	182.22	290.66	4147.5	290.03	7.951	122	0.6269	48.521	0.6082	0.6263	1.1477E+06
BFE4-3A-061981-9	148.66	307.81	4162.2	290.16	4.747	129	0.4830	48.669	0.6061	0.6242	8.8373E+05
BFE4-3A-072381-1	182.39	146.96	4057.2	290.28	31.475	63	1.2411	47.417	0.6119	0.6302	2.2730E+06
BFE4-3A-072381-2	143.00	243.52	4091.0	291.66	7.195	104	0.5872	47.564	0.6049	0.6229	1.0716E+06
BFE4-3A-072381-3	178.03	195.46	4079.3	291.19	17.359	84	0.9108	47.512	0.6042	0.6222	1.6641E+06
BFE4-3A-072381-4	177.76	118.75	4001.3	290.92	47.449	51	1.4970	46.649	0.6060	0.6241	2.7393E+06
BFE4-3A-072381-5	177.71	244.99	4135.5	291.65	10.772	105	0.7254	48.084	0.6071	0.6252	1.3230E+06
BFE4-3A-072381-6	156.03	256.35	4173.7	291.81	7.505	110	0.6086	48.500	0.6078	0.6259	1.1092E+06
BFE4-3A-072381-7	182.38	150.05	4083.9	291.27	30.113	64	1.2154	47.551	0.6118	0.6300	2.2202E+06
BFE4-3A-072381-8	182.75	238.59	4180.5	291.54	11.857	102	0.7660	48.629	0.6076	0.6258	1.3967E+06
BFE4-3A-072381-9	156.36	298.20	4199.1	291.90	5.507	127	0.5243	48.780	0.6096	0.6278	9.5508E+05
BFE4-3B-061881-1	184.48	239.67	4100.4	289.50	12.178	100	0.7697	48.065	0.6063	0.6244	1.4119E+06
BFE4-3B-061881-2	183.80	150.03	4073.4	289.09	30.996	63	1.2251	47.823	0.6063	0.6244	2.2501E+06
BFE4-3B-061881-3	184.32	207.75	4097.1	289.45	16.196	87	0.8872	48.037	0.6061	0.6242	1.6277E+06
BFE4-3B-061881-4	183.76	150.92	4073.7	288.74	30.296	63	1.2176	47.891	0.6091	0.6273	2.2383E+06
BFE4-3B-061881-5	184.33	295.77	4168.5	289.54	7.979	124	0.6232	48.859	0.6016	0.6196	1.1422E+06
BFE4-3B-061881-6	184.23	118.76	4032.3	288.66	49.645	50	1.5513	47.416	0.6093	0.6274	2.8535E+06
BFE4-3B-061881-7	184.65	294.88	4182.1	289.52	7.902	123	0.6262	49.022	0.6064	0.6245	1.1474E+06
BFE4-3B-061881-8	184.10	118.14	4045.7	288.87	50.227	49	1.5584	47.536	0.6077	0.6259	2.8647E+06
BFE4-3B-061881-9	185.23	350.42	4198.3	289.59	5.611	147	0.5286	49.200	0.6066	0.6247	9.6829E+05

Table 3(b) (cont.). Test Number, Measured and Calculated Quantities  
Nominal 3 Inch AGA/API Orifice Meter (SI Units).

Test Identification	Test Draft (kg)	Test Draft Time (s)	Press. Note 1 (kPa)	Temp. Note 2 (K)	Diff. Press. Note 3 (kPa)	Data Samples N	Mass Flow Rate (kg/s)	Orifice Meter Density (kg/m <sup>3</sup> )	CY <sub>2</sub>	KY <sub>2</sub>	Orifice Bore R <sub>d</sub>
BFE4-3B-072281-1	152.78	123.43	4062.3	289.78	31.610	53	1.2378	47.568	0.6083	0.6264	2.2701E+06
BFE4-3B-072281-2	153.16	259.42	4097.9	290.36	7.180	111	0.5904	47.880	0.6074	0.6256	1.0808E+06
BFE4-3B-072281-3	152.73	169.31	4107.3	289.92	16.608	72	0.9020	48.070	0.6084	0.6265	1.6528E+06
BFE4-3B-072281-4	152.55	97.94	4006.3	289.26	50.663	42	1.5576	47.003	0.6082	0.6264	2.8619E+06
BFE4-3B-072281-5	152.57	127.14	4040.5	289.43	29.962	55	1.2000	47.375	0.6070	0.6251	2.2032E+06
BFE4-3B-072281-6	153.03	198.81	4120.9	290.14	12.238	85	0.7697	48.189	0.6040	0.6220	1.4095E+06
BFE4-3B-072281-7	152.57	99.29	4006.5	289.35	49.511	43	1.5366	46.988	0.6070	0.6252	2.2228E+06
BFE4-3B-072281-8	152.85	258.71	4148.6	290.31	7.072	111	0.5908	48.481	0.6081	0.6263	1.0810E+06
BFE4-3B-072281-9	124.12	230.93	4160.2	290.00	5.873	99	0.5375	48.677	0.6060	0.6241	9.8402E+05
BFE3-4B-011982-1	176.98	83.99	3849.7	290.89	50.221	36	2.1072	44.882	0.6050	0.6397	3.3116E+06
BFE3-4B-011982-2	176.87	215.14	4083.4	291.42	7.110	92	0.8221	47.519	0.6097	0.6448	1.2869E+06
BFE3-4B-011982-3	176.37	115.77	3985.0	291.00	25.351	50	1.5234	46.443	0.6052	0.6400	2.3898E+06
BFE3-4B-011982-4	177.18	213.24	4045.5	291.19	7.426	91	0.8309	47.117	0.6055	0.6403	1.3019E+06
BFE3-4B-011982-5	177.18	286.33	4085.4	291.20	4.043	123	0.6188	47.580	0.6083	0.6433	9.6908E+05
BFE3-4B-011982-6	176.63	83.62	3819.8	289.82	50.318	36	2.1122	44.712	0.6070	0.6419	3.3292E+06
BFE3-4B-011982-7	177.04	160.29	4010.5	291.16	13.316	69	1.1045	46.714	0.6036	0.6383	1.7314E+06
BFE3-4B-011982-8	176.81	159.01	4007.7	291.10	13.429	68	1.1119	46.691	0.6053	0.6401	1.7434E+06
BFE3-4B-011982-9	176.54	339.96	4101.7	290.93	2.822	145	0.5193	47.821	0.6097	0.6448	8.1365E+05
BFE3-4B-012282-1	180.01	83.13	3853.7	288.98	51.977	36	2.1653	45.256	0.6086	0.6436	3.4185E+06
BFE3-4B-012282-2	180.08	221.87	4086.3	289.34	6.840	95	0.8117	47.930	0.6111	0.6462	1.2768E+06
BFE3-4B-012282-3	180.94	118.22	3983.9	289.28	25.161	51	1.5305	46.737	0.6084	0.6434	2.4109E+06
BFE3-4B-012282-4	180.28	225.10	4057.7	289.35	6.688	97	0.8009	47.592	0.6120	0.6472	1.2602E+06
BFE3-4B-012282-5	181.01	273.64	4099.8	289.24	4.514	117	0.6615	48.107	0.6120	0.6472	1.0406E+06
BFE3-4B-012282-6	180.49	86.88	3832.6	289.24	48.578	37	2.0775	44.962	0.6059	0.6408	3.2785E+06
BFE3-4B-012282-7	180.64	164.37	3994.0	289.53	13.063	70	1.0990	46.809	0.6058	0.6406	1.7298E+06
BFE3-4B-012282-8	180.58	163.54	3994.1	289.00	13.168	70	1.1042	46.904	0.6056	0.6405	1.7402E+06
BFE3-4B-012282-9	181.07	359.22	4099.1	289.23	2.595	154	0.5041	48.101	0.6152	0.6506	7.9297E+05
BFE4-4A-061981-1	185.65	279.94	4049.2	289.78	4.589	117	0.6632	47.414	0.6126	0.6479	1.0422E+06
BFE4-4A-061981-2	184.55	85.99	3906.8	287.54	50.002	36	2.1461	46.133	0.6087	0.6438	3.3968E+06
BFE4-4A-061981-3	184.35	218.67	4116.8	289.45	7.432	91	0.8431	48.268	0.6064	0.6414	1.3249E+06
BFE4-4A-061981-4	184.30	121.69	4056.8	288.80	23.742	51	1.5145	47.681	0.6132	0.6485	2.3856E+06
BFE4-4A-061981-5	184.47	167.73	4078.7	289.38	12.547	70	1.0998	47.833	0.6116	0.6468	1.7295E+06
BFE4-4A-061981-6	184.70	84.74	3923.0	289.56	51.317	36	2.1796	45.970	0.6113	0.6465	3.4324E+06
BFE4-4A-061981-7	184.48	123.98	4040.8	289.17	23.470	52	1.4880	47.426	0.6076	0.6426	2.3423E+06
BFE4-4A-061981-8	185.06	270.95	4150.4	289.77	4.784	113	0.6830	48.604	0.6103	0.6454	1.0722E+06
BFE4-4A-061981-9	156.15	285.95	4160.8	289.95	3.035	120	0.5461	48.691	0.6122	0.6475	8.5671E+05

Table 3(b) (cont.). Test Number, Measured and Calculated Quantities  
Nominal 3 Inch AGA/API Orifice Meter (SI Units).

Test Identification	Test Draft (kg)	Test Draft Time (s)	Press. Note 1 (kPa)	Temp. Note 2 (K)	Diff. Press. Note 3 (kPa)	Data Samples N	Mass Flow Rate (kg/s)	Orifice Meter Density (kg/m <sup>3</sup> )	CY <sub>2</sub>	KY <sub>2</sub>	Orifice Bore Rd
BFE4-4A-072181-1	164.99	144.03	4084.0	289.69	13.513	62	1.1455	47.839	0.6138	0.6491	1.8000E+06
BFE4-4A-072181-2	165.00	75.81	3931.7	289.68	51.360	33	2.1765	46.050	0.6096	0.6447	3.4261E+06
BFE4-4A-072181-3	164.84	236.09	4168.1	290.53	4.992	101	0.6982	48.671	0.6103	0.6455	1.0938E+06
BFE4-4A-072181-4	164.91	182.02	4130.7	290.06	8.443	78	0.9060	48.318	0.6111	0.6463	1.4216E+06
BFE4-4A-072181-5	164.89	107.01	4028.4	289.52	24.949	46	1.5409	47.216	0.6116	0.6468	2.4238E+06
BFE4-4A-072181-6	165.06	76.10	3901.6	288.75	50.874	33	2.1690	45.861	0.6117	0.6469	3.4233E+06
BFE4-4A-072181-7	165.23	245.34	4141.0	290.29	4.691	105	0.6735	48.397	0.6090	0.6440	1.0560E+06
BFE4-4A-072181-8	158.86	141.71	4068.0	289.67	13.069	61	1.1210	47.654	0.6119	0.6472	1.7619E+06
BFE4-4A-072181-9	127.38	254.03	4094.7	290.66	2.590	109	0.5014	47.788	0.6146	0.6500	7.8597E+05
BFE4-4B-070282-1	174.85	78.47	3912.0	287.21	53.297	30	2.282	46.254	0.6118	0.6470	3.5303E+06
BFE4-4B-070282-2	169.23	192.27	4232.4	287.99	7.841	71	0.8802	49.906	0.6065	0.6414	1.3865E+06
BFE4-4B-070282-3	168.91	106.02	4122.8	287.56	26.300	40	1.5932	48.690	0.6069	0.6418	2.5157E+06
BFE4-4B-070282-4	169.47	197.49	4194.4	288.11	7.505	73	0.8581	49.435	0.6074	0.6423	1.3521E+06
BFE4-4B-070282-5	169.82	250.84	4186.6	288.23	4.658	92	0.6770	49.319	0.6081	0.6441	1.0665E+06
BFE4-4B-070282-6	169.32	77.89	3872.9	287.45	51.908	29	2.1738	45.748	0.6081	0.6431	3.4437E+06
BFE4-4B-070282-7	168.95	151.19	4089.4	287.57	13.373	56	1.1175	48.293	0.5994	0.6339	1.7652E+06
BFE4-4B-070282-8	168.92	148.13	4088.1	287.75	13.580	55	1.1403	48.245	0.6073	0.6422	1.8006E+06
BFE4-4B-070282-9	169.19	204.35	4091.4	288.09	7.219	76	0.8280	48.220	0.6050	0.6398	1.3062E+06
BFE3-5A-012082-1	175.17	135.20	4038.9	290.72	9.652	58	1.2956	47.124	0.6063	0.6699	1.7777E+06
BFE3-5A-012082-2	175.45	73.35	3748.1	291.41	35.313	32	2.3919	43.609	0.6083	0.6721	3.2876E+06
BFE3-5A-012082-3	175.27	259.23	4148.4	291.41	2.521	111	0.6761	48.278	0.6118	0.6759	9.2498E+05
BFE3-5A-012082-4	179.37	136.29	4039.9	290.50	9.856	59	1.3161	47.175	0.6092	0.6731	1.8067E+06
BFE3-5A-012082-5	179.63	176.11	4071.8	291.09	5.725	76	1.0200	47.442	0.6177	0.6825	1.3978E+06
BFE3-5A-012082-6	179.80	74.26	3751.5	291.78	36.141	32	2.4213	43.589	0.6088	0.6726	3.3250E+06
BFE3-5A-012082-7	179.90	216.71	4109.3	291.54	3.753	93	0.8301	47.798	0.6186	0.6835	1.1359E+06
BFE3-5A-012082-8	179.91	266.85	4118.8	291.31	2.530	114	0.6742	47.950	0.6109	0.6750	9.2288E+05
BFE3-5B-012082-1	183.41	229.65	4082.5	291.47	3.588	98	0.7986	47.499	0.6112	0.6752	1.0937E+06
BFE3-5B-012082-2	183.04	141.24	4007.4	291.35	9.649	61	1.2959	46.643	0.6102	0.6741	1.7768E+06
BFE3-5B-012082-3	183.87	280.50	4042.1	291.35	2.473	120	0.6555	47.049	0.6072	0.6707	8.9841E+05
BFE3-5B-012082-4	183.26	103.46	3913.1	290.95	18.643	44	1.7713	45.612	0.6068	0.6703	2.4335E+06
BFE3-5B-012082-5	183.21	186.72	3996.5	291.28	5.609	80	0.9812	46.528	0.6068	0.6703	1.3457E+06
BFE3-5B-012082-6	178.94	76.04	3689.0	289.11	34.561	33	2.3532	43.293	0.6078	0.6714	3.2560E+06
BFE3-5B-012082-7	175.39	175.12	3964.8	291.17	5.886	77	1.0016	46.178	0.6069	0.6705	1.3745E+06
BFE3-5B-012082-8	170.18	129.73	3964.6	291.25	10.095	57	1.3118	46.161	0.6071	0.6706	1.7999E+06
BFE3-5B-012082-9	170.50	216.52	4034.4	291.31	3.528	95	0.7875	46.965	0.6112	0.6752	1.0794E+06



Table 3(b) (cont.). Test Number, Measured and Calculated Quantities  
Nominal 3 Inch AGA/API Orifice Meter (SI Units).

Test Identification	Test Draft (kg)	Test Draft Time (s)	Press. Note 1 (kPa)	Temp. Note 2 (K)	Diff. Press. Note 3 (kPa)	Data Samples N	Mass Flow Rate (kg/s)	Orifice Meter Density (kg/m <sup>3</sup> )	CY <sub>2</sub>	KY <sub>2</sub>	Orifice Bore R <sub>d</sub>
BFE4-5A-070282-1	173.81	131.76	4057.4	287.49	9.641	48	1.3191	47.428	0.6125	0.6767	1.8236E+06
BFE4-5A-070282-2	174.31	71.46	3758.3	286.62	35.368	26	2.4393	44.530	0.6135	0.6778	3.3913E+06
BFE4-5A-070282-3	174.53	247.53	4123.2	288.24	2.743	88	0.7051	48.567	0.6100	0.6740	9.7219E+05
BFE4-5A-070282-4	173.99	127.80	4064.5	287.51	10.370	47	1.3615	48.009	0.6090	0.6729	1.8818E+06
BFE4-5A-070282-5	174.32	175.91	4091.7	287.91	5.504	65	0.9910	48.257	0.6069	0.6706	1.3679E+06
BFE4-5A-070282-6	174.54	71.88	3753.9	286.17	35.313	27	2.4282	44.555	0.6110	0.6751	3.3799E+06
BFE4-5A-070282-7	174.86	206.21	4107.5	288.15	3.948	76	0.8480	48.399	0.6123	0.6766	1.1697E+06
BFE4-5A-070282-8	174.85	247.18	4097.8	288.32	2.767	91	0.7074	48.254	0.6111	0.6752	9.7546E+05
BFE4-5A-070282-9	174.24	94.67	3956.9	287.84	19.553	36	1.8405	46.675	0.6081	0.6719	2.5453E+06
BFE4-5B-070882-1	165.64	195.21	4206.6	288.44	3.924	66	0.8485	49.515	0.6082	0.6719	1.1687E+06
BFE4-5B-070882-2	171.68	124.60	4143.0	287.59	10.456	44	1.3779	48.924	0.6086	0.6724	1.9031E+06
BFE4-5B-070882-3	171.54	247.74	4220.4	288.44	2.583	87	0.6924	49.678	0.6108	0.6747	9.5351E+05
BFE4-5B-070882-4	171.93	90.14	4077.3	287.54	19.820	32	1.9074	48.155	0.6169	0.6814	2.6369E+06
BFE4-5B-070882-5	171.65	166.45	4205.5	287.76	5.832	58	1.0313	49.632	0.6056	0.6690	1.4227E+06
BFE4-5B-070882-6	171.50	69.41	3830.4	287.83	36.208	25	2.4709	45.178	0.6103	0.6742	3.4236E+06
BFE4-5B-070882-7	171.87	165.81	4140.9	287.75	6.024	58	1.0365	48.869	0.6036	0.6668	1.4311E+06
BFE4-5B-070882-8	171.74	125.43	4087.4	287.54	10.426	44	1.3692	48.275	0.6098	0.6736	1.8927E+06
BFE4-5B-070882-9	172.10	205.82	4118.6	288.16	3.852	72	0.8362	48.529	0.6111	0.6750	1.1537E+06
BFE4-5B-070882-10	163.14	194.53	4124.0	288.20	3.840	68	0.8386	48.585	0.6135	0.6778	1.1569E+06
BFE3-6B-012182-3	180.55	74.69	3719.7	287.47	19.467	32	2.4174	43.927	0.6079	0.7210	2.9840E+06
BFE3-6B-012182-4	180.53	148.77	3994.9	288.81	4.603	64	1.2135	46.950	0.6070	0.7200	1.4883E+06
BFE3-6B-012182-5	180.45	120.63	3971.9	288.76	7.018	52	1.4959	46.686	0.6077	0.7208	1.8353E+06
BFE3-6B-012182-6	180.69	75.41	3714.3	287.16	19.171	32	2.3960	43.916	0.6073	0.7202	2.9602E+06
BFE3-6B-012182-7	180.84	178.59	4013.5	289.10	3.184	77	1.0126	47.116	0.6080	0.7211	1.2407E+06
BFE3-6B-012182-8	180.58	152.86	4009.6	289.00	4.336	65	1.1813	47.089	0.6079	0.7210	1.4479E+06
BFE3-6B-012182-9	180.79	97.93	3910.8	289.39	10.916	42	1.8461	45.857	0.6067	0.7196	2.2632E+06
BFE3-6B-012182-10	180.68	199.06	4016.7	288.77	2.542	85	0.8077	47.213	0.6093	0.7227	1.1130E+06
BFE4-6A-061781-1	182.48	75.05	3814.6	289.54	19.286	32	2.4315	44.698	0.6092	0.7225	2.9836E+06
BFE4-6A-061781-2	157.89	105.09	4000.9	289.70	7.020	44	1.5024	46.861	0.6094	0.7227	1.8389E+06
BFE4-6A-061781-3	157.65	159.76	4019.6	289.89	3.033	67	0.9868	47.046	0.6079	0.7208	1.2069E+06
BFE4-6A-061781-4	184.27	119.30	4089.2	289.63	7.265	50	1.5446	47.912	0.6090	0.7223	1.8888E+06
BFE4-6A-061781-5	184.26	91.79	4006.3	289.57	12.578	38	2.0074	46.948	0.6077	0.7207	2.4576E+06
BFE4-6A-061781-6	184.31	143.54	4075.4	289.55	5.098	60	1.2840	47.763	0.6054	0.7179	1.5708E+06
BFE4-6A-061781-7	184.48	198.69	4062.6	289.55	2.638	83	0.9285	47.613	0.6095	0.7228	1.1360E+06
BFE4-6A-061781-8	184.35	171.96	4120.6	289.50	3.456	72	1.0721	48.303	0.6104	0.7239	1.3109E+06
BFE4-6A-061781-9	184.25	139.61	4090.0	289.35	5.333	59	1.3197	47.972	0.6071	0.7199	1.6149E+06

Table 3(b) (cont.). Test Number, Measured and Calculated Quantities  
Nominal 3 Inch AGA/API Orifice Meter (SI Units).

Test Identification	Test Draft (kg)	Test Draft Time (s)	Press. Note 1 (kPa)	Temp. Note 2 (K)	Diff. Press. Note 3 (kPa)	Data Samples N	Mass Flow Rate (kg/s)	Orifice Meter Density (kg/m <sup>3</sup> )	CY <sub>2</sub>	KY <sub>2</sub>	Orifice Bore Rd
BFE4-6A-072281-1	178.98	175.63	4'24.2	289.71	3.128	75	1.0191	48.307	0.6102	0.7237	1.2454E+06
BFE4-6A-072281-2	176.47	88.17	4028.4	289.40	12.436	38	2.0015	47.238	0.6075	0.7204	2.4507E+06
BFE4-6A-072281-3	176.47	194.07	4175.4	290.07	2.503	83	0.9093	48.842	0.6051	0.7176	1.1097E+06
BFE4-6A-072281-4	176.44	136.99	4096.0	289.60	5.030	59	1.2880	47.996	0.6099	0.7232	1.5750E+06
BFE4-6A-072281-5	176.79	174.20	4106.1	289.74	3.126	75	1.0149	48.089	0.6090	0.7222	1.2405E+06
BFE4-6A-072281-6	177.20	72.43	3877.1	288.87	19.161	31	2.4465	45.550	0.6092	0.7225	3.0048E+06
BFE4-6A-072281-7	176.82	111.95	4093.8	289.67	7.676	48	1.5794	47.958	0.6056	0.7182	1.9311E+06
BFE4-6A-072281-8	176.86	195.61	4153.4	290.22	2.485	84	0.9042	48.556	0.6057	0.7183	1.1033E+06
BFE4-6A-072281-9	177.33	72.79	3870.5	289.57	19.239	31	2.4361	45.352	0.6067	0.7195	2.9872E+06
BFE4-6B-070882-1	159.16	167.90	4102.7	288.07	2.696	63	0.9480	48.358	0.6105	0.7241	1.1631E+06
BFE4-6B-070882-2	167.85	159.94	4086.1	287.84	3.341	60	1.0494	48.204	0.6081	0.7212	1.2886E+06
BFE4-6B-070882-3	168.12	68.05	3784.0	286.46	19.547	26	2.4705	44.863	0.6135	0.7276	3.0548E+06
BFE4-6B-070882-4	167.47	140.14	4056.9	287.73	4.500	53	1.1950	47.879	0.5987	0.7101	1.4683E+06
BFE4-6B-070882-5	168.32	111.94	4022.5	287.14	6.918	42	1.5037	47.579	0.6095	0.7229	1.8510E+06
BFE4-6B-070882-6	165.87	68.60	3754.2	285.57	19.148	26	2.4179	44.661	0.6080	0.7212	2.9973E+06
BFE4-6B-070882-7	167.99	162.20	4081.3	288.06	3.267	61	1.0357	48.107	0.6076	0.7206	1.2712E+06
BFE4-6B-070882-8	167.99	137.91	4043.6	287.75	4.629	52	1.2181	47.717	0.6027	0.7148	1.4968E+06
BFE4-6B-070882-9	167.12	88.13	3940.7	287.29	11.391	33	1.8963	46.580	0.6054	0.7180	2.3357E+06

Note 1: Orifice meter pressure measured at the downstream flange tap and calculated as a simple average of N data samples during Draft Time.

Note 2: Flowing gas temperature measured downstream of the meter and calculated as a simple average of N data samples taken during Draft Time.

Note 3: Differential pressure measured between the flange taps and calculated as the square of the average of the square roots of N data samples taken during Draft Time.

Table 4(a). Test Meter Identification and Physical Measurements  
Nominal 4 Inch AGA/API Orifice Meter (SI Units).

Test Identification	Test Configuration	Run Diameter (cm)	Orifice Diameter (cm)	Beta Ratio
BF E5-2A-060281-[9]	1981-A	10.217	3.8082	0.3728
BF E5-2A-060581-[9]	1981-A	10.217	3.8082	0.3728
BF E5-2A-080481-[7]	1981-A	10.217	3.8082	0.3728
BF E5-2A-080581-[7]	1981-A	10.217	3.8082	0.3728
BF E5-2B-060481-[10]	1981-A	10.217	3.8090	0.3728
BF E5-2B-080581-[9]	1981-A	10.217	3.8090	0.3728
BF E5-2B-101581-[9]	1981-A	10.217	3.8090	0.3728
BF E6-2A-052181-[11]	1981-A	10.226	3.8082	0.3724
BF E6-2B-052281-[10]	1981-A	10.226	3.8090	0.3725
BF E6-2B-052881-[8]	1981-A	10.226	3.8090	0.3725
BF E5-3A-060281-[9]	1981-A	10.217	5.0775	0.4970
BF E5-3B-111281-[9]	1981-A	10.217	5.0780	0.4970
BF E6-3A-051481-[10]	1981-A	10.226	5.0775	0.4965
BF E6-3A-051581-[9]	1981-A	10.226	5.0775	0.4965
BF E6-3A-052781-[8]	1981-A	10.226	5.0775	0.4965
BF E6-3A-022582-[9]	1981-A	10.226	5.0775	0.4965
BF E6-3B-022482-[9]	1981-A	10.226	5.0780	0.4966
BF E5-4A-080681-[9]	1981-A	10.217	5.7127	0.5592
BF E5-4A-101681-[10]	1981-A	10.217	5.7127	0.5592
BF E5-4B-102281-[9]	1981-A	10.217	5.7137	0.5593
BF E6-4A-102882-[9]	1981-A	10.226	5.7127	0.5586
BF E6-4B-022582-[9]	1981-A	10.226	5.7137	0.5587
BF E6-4B-100182-[9]	1981-A	10.226	5.7137	0.5587
BF E5-5A-060381-[9]	1981-A	10.217	6.6660	0.6525
BF E5-5A-060481-[10]	1981-A	10.217	6.6660	0.6525
BF E5-5B-102081-[9]	1981-A	10.217	6.6670	0.6526
BF E6-5A-052781-[10]	1981-A	10.226	6.6660	0.6519
BF E6-5A-052981-[11]	1981-A	10.226	6.6660	0.6519
BF E6-5B-022482-[9]	1981-A	10.226	6.6670	0.6520
BF E6-5B-092982-[7]	1981-A	10.226	6.6670	0.6520
BF E5-6A-080681-[9]	1981-A	10.217	7.6203	0.7459
BF E5-6B-102081-[8]	1981-A	10.217	7.6182	0.7457
BF E6-6A-102982-[9]	1981-A	10.226	7.6203	0.7452
BF E6-6B-093082-[9]	1981-A	10.226	7.6182	0.7450
BF E6-6B-100782-[9]	1981-A	10.226	7.6182	0.7450

Note: Test Identification bracket gives number of tests run with this geometry. A total of 316 tests were run on the nominal 4 inch run size.

Table 4(b). Test Number, Measured and Calculated Quantities  
Nominal 4 Inch AGA/API Orifice Meter (SI Units).

Test Identification	Test Draft (kg)	Test Draft Time (s)	Press. Note 1 (kPa)	Temp. Note 2 (K)	Diff. Press. Note 3 (kPa)	Data Samples N	Mass Flow Rate (kg/s)	Orifice Meter Density (kg/m <sup>3</sup> )	CY <sub>2</sub>	KY <sub>2</sub>	Orifice Bore Rd
BFE5-2A-060281-1	168.04	229.28	4130.0	288.31	11.565	96	0.7329	48.634	0.6010	0.6069	1.3481E+06
BFE5-2A-060281-2	167.90	106.17	4040.0	288.20	53.680	45	1.5815	47.593	0.6084	0.6143	2.9129E+06
BFE5-2A-060281-3	167.91	150.52	4089.9	288.03	26.827	63	1.1155	48.213	0.6032	0.6091	2.0542E+06
BFE5-2A-060281-4	167.89	179.42	4138.6	288.03	18.926	75	0.9357	48.790	0.5988	0.6047	1.7222E+06
BFE5-2A-060281-5	168.07	108.98	4039.7	287.71	51.766	46	1.5422	47.678	0.6036	0.6095	2.8438E+06
BFE5-2A-060281-6	168.19	151.32	4085.3	287.91	26.694	64	1.1115	48.182	0.6028	0.6087	2.0476E+06
BFE5-2A-060281-7	142.95	226.46	4174.0	288.37	8.530	95	0.6312	49.145	0.5996	0.6054	1.1603E+06
BFE5-2A-060281-8	154.82	170.37	4154.5	287.83	17.716	71	0.9087	49.014	0.5997	0.6056	1.6729E+06
BFE5-2A-060281-9	141.64	268.56	4176.7	288.48	5.949	112	0.5274	49.154	0.6002	0.6060	9.6915E+05
BFE5-2A-060581-1	179.67	250.50	4116.9	288.68	11.057	105	0.7172	48.411	0.6029	0.6088	1.3183E+06
BFE5-2A-060581-2	179.50	287.35	4157.9	288.70	8.416	120	0.6247	48.892	0.5989	0.6047	1.1476E+06
BFE5-2A-060581-3	179.54	115.44	4015.7	288.01	52.764	48	1.5552	47.339	0.6051	0.6110	2.8667E+06
BFE5-2A-060581-4	179.44	160.15	4062.9	288.13	27.240	67	1.1205	47.874	0.6033	0.6092	2.0635E+06
BFE5-2A-060581-5	179.16	115.01	4010.0	288.53	53.431	48	1.5578	47.178	0.6033	0.6092	2.8680E+06
BFE5-2A-060581-6	179.00	196.75	4129.0	288.38	17.940	83	0.9098	48.611	0.5991	0.6050	1.6732E+06
BFE5-2A-060581-7	177.44	236.45	4142.9	288.49	12.077	99	0.7505	48.753	0.6014	0.6073	1.3796E+06
BFE5-2A-060581-8	177.49	156.46	4055.4	288.09	27.750	66	1.1344	47.793	0.6057	0.6117	2.0896E+06
BFE5-2A-060581-9	178.42	363.54	4143.6	289.80	5.198	152	0.4908	48.518	0.6013	0.6071	8.9942E+05
BFE5-2A-080481-1	177.07	244.69	4159.4	291.23	11.398	105	0.7237	48.440	0.5989	0.6048	1.3214E+06
BFE5-2A-080481-2	176.69	117.32	4012.0	290.20	50.739	50	1.5060	46.901	0.6003	0.6061	2.7616E+06
BFE5-2A-080481-3	176.94	162.82	4060.2	290.69	26.048	70	1.0867	47.378	0.6016	0.6075	1.9893E+06
BFE5-2A-080481-4	177.31	196.92	4086.4	290.80	17.695	84	0.9004	47.665	0.6029	0.6088	1.6473E+06
BFE5-2A-080481-5	176.73	114.89	4001.5	289.56	52.704	49	1.5382	46.892	0.6016	0.6075	2.8253E+06
BFE5-2A-080481-6	176.89	161.33	4054.3	290.63	26.947	69	1.0965	47.320	0.5971	0.6029	2.0755E+06
BFE5-2A-080481-7	177.75	315.54	4168.2	291.29	6.885	135	0.5633	48.531	0.5994	0.6053	1.0284E+06
BFE5-2A-080581-1	188.99	251.68	4126.8	291.49	12.335	108	0.7509	48.013	0.6000	0.6059	1.3709E+06
BFE5-2A-080581-2	187.77	299.50	4159.4	291.46	8.506	128	0.6269	48.397	0.6010	0.6068	1.1442E+06
BFE5-2A-080581-3	187.60	125.41	4025.6	290.43	49.322	54	1.4959	47.021	0.6040	0.6099	2.7411E+06
BFE5-2A-080581-4	187.71	172.00	4067.5	290.84	26.148	74	1.0913	47.436	0.6026	0.6085	1.9968E+06
BFE5-2A-080581-5	188.04	248.13	4147.0	291.21	12.445	106	0.7578	48.298	0.6011	0.6070	1.3841E+06
BFE5-2A-080581-6	187.93	124.08	4031.4	290.31	50.435	53	1.5146	47.109	0.6042	0.6101	2.7760E+06
BFE5-2A-080581-7	188.54	314.41	4184.0	291.43	7.691	135	0.5996	48.690	0.6027	0.6086	1.0941E+06

Table 4(b) (cont.). Test Number, Measured and Calculated Quantities  
Nominal 4 Inch AGA/API Orifice Meter (SI Units).

Test Identification	Test Draft (kg)	Test Draft Time (s)	Press. Note 1 (kPa)	Temp. Note 2 (K)	Diff. Press. Note 3 (kPa)	Data Samples N	Mass Flow Rate (kg/s)	Orifice Meter Density (kg/m <sup>3</sup> )	CY <sub>1</sub>	KY <sub>1</sub>	Orifice Bore Rd
BFES-2B-060481-1	155.74	256.71	4172.5	288.82	7.803	107	0.6067	49.042	0.6029	0.6088	1.1138E+06
BFES-2B-060481-2	168.71	107.93	4035.5	288.33	52.644	45	1.5631	47.515	0.6075	0.6134	2.8777E+06
BFES-2B-060481-3	149.36	240.77	4175.1	288.78	8.102	101	0.6204	49.079	0.6048	0.6107	1.1390E+06
BFES-2B-060481-4	159.86	203.31	4156.0	288.48	13.113	85	0.7863	48.910	0.6036	0.6095	1.4450E+06
BFES-2B-060481-5	159.43	169.11	4147.1	288.31	18.741	71	0.9428	48.837	0.6057	0.6117	1.7334E+06
BFES-2B-060481-6	159.71	141.77	4097.2	288.38	26.725	59	1.1265	48.235	0.6099	0.6159	2.0722E+06
BFES-2B-060481-7	159.57	209.35	4163.8	288.65	12.378	88	0.7622	48.969	0.6018	0.6077	1.4000E+06
BFES-2B-060481-8	159.35	174.99	4150.9	288.39	17.713	73	0.9106	48.868	0.6017	0.6076	1.6739E+06
BFES-2B-060481-9	153.80	289.41	4177.3	288.65	5.963	121	0.5314	49.130	0.6037	0.6096	9.7594E+05
BFES-2B-060481-10	167.61	144.85	4089.5	287.96	27.965	61	1.1571	48.221	0.6125	0.6185	2.1308E+06
BFES-2B-080581-1	179.26	241.24	4117.1	290.78	11.818	103	0.7431	48.029	0.6063	0.6122	1.3587E+06
BFES-2B-080581-2	178.96	165.14	4068.9	290.19	24.990	71	1.0837	47.570	0.6109	0.6169	1.9855E+06
BFES-2B-080581-3	179.19	194.44	4101.8	290.48	18.291	83	0.9216	47.903	0.6052	0.6111	1.6866E+06
BFES-2B-080581-4	179.45	164.18	4053.3	290.31	25.829	70	1.0930	47.367	0.6080	0.6139	2.0024E+06
BFES-2B-080581-5	179.48	245.98	4137.8	290.94	11.396	105	0.7297	48.241	0.6049	0.6109	1.3334E+06
BFES-2B-080581-6	179.79	291.40	4158.3	290.67	8.053	125	0.6170	48.529	0.6068	0.6127	1.1279E+06
BFES-2B-080581-7	179.28	198.03	4111.2	290.60	17.414	85	0.9053	47.992	0.6087	0.6146	1.6562E+06
BFES-2B-080581-8	179.24	117.72	4018.0	289.88	50.168	51	1.5226	47.029	0.6092	0.6152	2.7933E+06
BFES-2B-080581-9	153.75	279.36	4174.2	290.96	6.410	119	0.5503	48.662	0.6059	0.6118	1.0052E+06
BFES-2B-101581-1	168.63	149.49	4040.8	290.00	27.600	64	1.1280	47.276	0.6069	0.6129	2.0684E+06
BFES-2B-101581-2	168.35	192.13	4122.5	290.21	16.385	82	0.8762	48.195	0.6061	0.6120	1.6042E+06
BFES-2B-101581-3	159.75	269.15	4174.5	290.20	7.424	115	0.5935	48.807	0.6062	0.6121	1.0860E+06
BFES-2B-101581-4	159.76	145.92	4086.6	290.04	25.629	63	1.0948	47.806	0.6079	0.6139	2.0062E+06
BFES-2B-101581-5	153.34	248.85	4168.3	290.21	8.026	107	0.6162	48.731	0.6058	0.6117	1.1276E+06
BFES-2B-101581-6	153.75	216.16	4123.4	290.14	10.903	92	0.7113	48.218	0.6030	0.6089	1.3025E+06
BFES-2B-101581-7	153.04	102.03	4012.5	289.90	49.237	44	1.5000	46.961	0.6063	0.6122	2.7519E+06
BFES-2B-101581-8	154.30	179.83	4077.2	290.06	16.124	77	0.8580	47.691	0.6014	0.6073	1.5723E+06
BFES-2B-101581-9	153.85	275.62	4145.7	290.04	6.596	118	0.5582	48.498	0.6069	0.6128	1.0221E+06
BFES-2B-101581-10	167.66	143.00	4069.9	291.91	29.635	60	1.1724	47.273	0.6091	0.6150	2.1397E+06
BFES-2B-101581-11	168.12	231.73	4129.3	292.11	11.291	97	0.7255	47.929	0.6067	0.6126	1.3225E+06
BFES-2B-101581-12	167.78	111.67	4013.7	291.61	50.136	47	1.5025	46.671	0.6039	0.6098	2.7458E+06
BFES-2A-052181-4	167.86	193.91	4108.1	292.18	16.399	81	0.8657	47.668	0.6021	0.6079	1.5781E+06
BFES-2A-052181-5	154.48	265.64	4108.5	292.12	7.400	111	0.5815	47.684	0.6024	0.6083	1.6030E+06
BFES-2A-052181-6	154.62	140.62	4067.5	292.22	27.021	59	1.0996	47.191	0.5988	0.6046	2.0054E+06
BFES-2A-052181-7	154.85	255.46	4118.3	292.46	8.132	107	0.6062	47.738	0.5983	0.6042	1.1042E+06
BFES-2A-052181-8	154.13	138.03	4089.3	292.25	27.358	58	1.1166	47.437	0.6027	0.6085	2.0358E+06
BFES-2A-052181-9	154.31	210.88	4180.4	292.61	11.691	88	0.7318	48.430	0.5981	0.6039	1.3316E+06
BFES-2A-052181-10	144.41	278.64	4192.6	292.24	5.809	116	0.5182	48.640	0.5998	0.6056	9.4372E+05
BFES-2A-052181-11	143.23	277.10	4199.6	292.19	5.726	116	0.5169	48.732	0.6025	0.6084	9.4132E+05

Table 4(b) (cont.). Test Number, Measured and Calculated Quantities  
Nominal 4 Inch AGA/API Orifice Meter (SI Units).

Test Identification	Test Draft (kg)	Test Draft Time (s)	Press. Note 1 (kPa)	Temp. Note 2 (K)	Diff. Press. Note 3 (kPa)	Data Samples N	Mass Flow Rate (kg/s)	Orifice Meter Density (kg/m <sup>3</sup> )	CY <sub>2</sub>	KY <sub>2</sub>	Orifice Bore R <sub>d</sub>
BFEG-2B-052281-1	170.90	236.60	4120.1	287.30	11.143	99	0.7223	48.707	0.6028	0.6086	1.3317E+06
BFEG-2B-052281-2	170.71	109.78	4033.9	287.28	51.706	46	1.5550	47.688	0.6087	0.6147	2.8701E+06
BFEG-2B-052281-3	166.73	186.31	4129.6	287.31	16.928	78	0.8949	48.817	0.6052	0.6111	1.6497E+06
BFEG-2B-052281-4	167.07	273.32	4162.0	287.67	7.817	114	0.6113	49.134	0.6064	0.6123	1.1254E+06
BFEG-2B-052281-5	166.51	144.77	4080.1	286.78	27.939	60	1.1502	48.329	0.6084	0.6144	2.1242E+06
BFEG-2B-052281-6	167.08	277.68	4158.8	287.59	7.624	116	0.6017	49.112	0.6046	0.6105	1.1081E+06
BFEG-2B-052281-7	166.45	147.78	4074.1	287.00	27.060	62	1.1263	48.217	0.6062	0.6122	2.0793E+06
BFEG-2B-052281-8	166.85	229.31	4156.6	287.24	11.116	96	0.7276	49.151	0.6052	0.6111	1.3411E+06
BFEG-2B-052281-10	166.45	106.83	4016.7	287.70	52.551	45	1.5581	47.407	0.6068	0.6127	2.8734E+06
BFEG-2B-052281-11	167.35	316.31	4122.5	287.42	5.832	132	0.5291	48.713	0.6108	0.6168	9.7516E+05
BFEG-2B-052881-1	188.78	205.62	4112.2	288.14	17.980	86	0.9181	48.455	0.6046	0.6105	1.6894E+06
BFEG-2B-052881-2	185.69	121.64	4011.3	287.79	50.542	51	1.5266	47.327	0.6067	0.6126	2.8149E+06
BFEG-2B-052881-3	146.10	187.24	4095.4	288.02	12.984	78	0.7803	48.281	0.6058	0.6118	1.4366E+06
BFEG-2B-052881-4	153.16	176.04	4095.9	287.92	16.185	74	0.8701	48.305	0.6049	0.6108	1.6022E+06
BFEG-2B-052881-5	151.07	198.32	4132.9	288.08	12.310	83	0.7618	48.712	0.6048	0.6107	1.4016E+06
BFEG-2B-052881-6	159.55	103.20	4002.7	287.57	51.951	43	1.5460	47.264	0.6065	0.6124	2.8526E+06
BFEG-2B-052881-7	159.36	140.55	4045.1	288.00	27.860	59	1.1338	47.690	0.6046	0.6105	2.0888E+06
BFEG-2B-052881-8	160.14	247.52	4120.0	288.29	8.954	103	0.6470	48.522	0.6035	0.6094	1.1900E+06
BFEG-3A-060281-1	159.53	117.69	4090.1	288.33	11.923	49	1.3555	48.160	0.6055	0.6248	1.8708E+06
BFEG-3A-060281-2	162.15	190.11	4127.4	288.41	4.711	79	0.8529	48.586	0.6035	0.6228	1.1765E+06
BFEG-3A-060281-3	163.50	93.80	4026.9	288.04	20.021	39	1.7431	47.467	0.6052	0.6245	2.4093E+06
BFEG-3A-060281-4	164.48	187.14	4089.2	288.53	5.054	78	0.8789	48.112	0.6035	0.6228	1.2125E+06
BFEG-3A-060281-5	164.18	123.40	4077.6	288.10	11.529	52	1.3305	48.055	0.6050	0.6244	1.8376E+06
BFEG-3A-060281-6	163.95	91.95	4026.4	288.00	21.130	39	1.7831	47.468	0.6026	0.6219	2.4648E+06
BFEG-3A-060281-7	164.29	67.33	3867.0	288.23	41.113	28	2.4400	45.542	0.6035	0.6228	3.3775E+06
BFEG-3A-060281-8	149.37	146.25	4129.3	288.11	6.644	61	1.0213	48.664	0.6080	0.6274	1.4097E+06
BFEG-3A-060281-9	151.16	254.91	4197.7	288.61	2.260	107	0.5930	49.379	0.6010	0.6202	8.1684E+05
BFEG-3B-111281-1	179.18	139.13	4058.4	291.58	10.909	60	1.2879	47.198	0.6073	0.6267	1.7643E+06
BFEG-3B-111281-2	179.62	246.35	4106.0	291.77	3.418	105	0.7291	47.719	0.6110	0.6305	9.9784E+05
BFEG-3B-111281-3	179.27	101.42	3970.1	290.90	20.723	43	1.7676	46.287	0.6107	0.6302	2.4279E+06
BFEG-3B-111281-4	179.47	188.48	4031.6	291.58	5.976	81	0.9522	46.886	0.6088	0.6282	1.3048E+06
BFEG-3B-111281-5	179.25	138.59	4014.4	291.03	10.917	59	1.2934	46.782	0.6124	0.6320	1.7751E+06
BFEG-3B-111281-6	179.32	102.92	3975.1	291.30	20.337	44	1.7424	46.276	0.6077	0.6271	2.3908E+06
BFEG-3B-111281-7	179.75	74.74	3791.3	290.28	40.552	32	2.4050	44.301	0.6071	0.6265	3.3152E+06
BFEG-3B-111281-8	179.40	182.79	4042.9	291.46	6.342	78	0.9814	47.037	0.6080	0.6275	1.3451E+06
BFEG-3B-111281-9	161.77	271.41	4097.2	291.97	2.311	116	0.5960	47.580	0.6084	0.6279	8.1539E+05

Table 4(b) (cont.). Test Number, Measured and Calculated Quantities  
Nominal 4 Inch AGA/API Orifice Meter (SI Units).

Test Identification	Test Draft (kg)	Test Draft Time (s)	Press. Note 1 (kPa)	Temp. Note 2 (K)	Diff. Press. Note 3 (kPa)	Data Samples N	Mass Flow Rate (kg/s)	Orifice Meter Density (kg/m <sup>3</sup> )	CY <sub>2</sub>	KY <sub>2</sub>	Orifice Bore R <sub>d</sub>
BFE6-3A-051481-1	173.10	84.78	3919.2	291.91	28.626	30	2.0418	45.519	0.6054	0.6247	2.7998E+06
BFE6-3A-051481-2	181.36	181.86	4052.0	291.89	6.546	63	0.9972	47.069	0.6081	0.6275	1.3654E+06
BFE6-3A-051481-3	179.85	210.82	4086.5	291.84	4.711	73	0.8531	47.480	0.6109	0.6303	1.1677E+06
BFE6-3A-051481-4	180.66	136.99	4041.5	291.89	11.562	48	1.3188	46.946	0.6059	0.6252	1.8059E+06
BFE6-3A-051481-5	180.79	102.99	3982.0	291.77	20.835	36	1.7554	46.273	0.6051	0.6244	2.4061E+06
BFE6-3A-051481-6	181.00	136.59	4046.8	291.93	11.704	48	1.3251	47.001	0.6047	0.6240	1.8143E+06
BFE6-3A-051481-7	181.12	87.21	3946.8	289.72	29.039	30	2.0768	46.221	0.6068	0.6261	2.8618E+06
BFE6-3A-051481-8	181.49	217.22	4091.4	292.02	4.591	75	0.8355	47.503	0.6056	0.6249	1.1431E+06
BFE6-3A-051481-9	151.19	258.54	4015.0	292.50	2.216	90	0.5848	46.530	0.6171	0.6368	7.9986E+05
BFE6-3A-051481-10	151.71	236.46	4016.9	292.40	2.739	82	0.6416	46.570	0.6082	0.6276	8.7775E+05
BFE6-3A-051581-2	181.57	184.59	4004.6	292.29	6.516	77	0.9836	46.446	0.6052	0.6245	1.3462E+06
BFE6-3A-051581-3	182.03	222.04	4008.7	292.17	4.463	93	0.8198	46.515	0.6091	0.6285	1.1222E+06
BFE6-3A-051581-4	181.65	138.88	3977.6	292.08	11.577	58	1.3080	46.169	0.6055	0.6248	1.7916E+06
BFE6-3A-051581-5	181.67	103.90	3988.8	292.04	20.322	44	1.7485	46.307	0.6101	0.6295	2.3949E+06
BFE6-3A-051581-6	182.37	137.11	4042.1	292.17	11.737	57	1.3301	46.902	0.6068	0.6261	1.8201E+06
BFE6-3A-051581-7	182.67	89.44	3953.1	290.17	28.094	38	2.0424	46.216	0.6067	0.6260	2.8111E+06
BFE6-3A-051581-8	182.84	213.78	4107.6	292.30	4.760	89	0.8553	47.642	0.6081	0.6274	1.1691E+06
BFE6-3A-051581-9	183.57	290.80	4050.6	292.34	2.640	122	0.6313	46.972	0.6070	0.6264	8.6340E+05
BFE6-3A-051581-10	182.99	105.20	3984.4	292.35	20.601	44	1.7394	46.202	0.6034	0.6227	2.3808E+06
BFE6-3A-052781-1	173.69	207.10	4074.7	288.15	4.580	87	0.8387	48.011	0.6055	0.6248	1.1582E+06
BFE6-3A-052781-2	174.07	72.19	3894.7	287.23	38.993	30	2.4112	46.046	0.6091	0.6286	3.3447E+06
BFE6-3A-052781-3	173.95	130.43	4046.6	287.46	11.477	55	1.3337	47.806	0.6095	0.6290	1.8455E+06
BFE6-3A-052781-4	173.88	97.51	3978.2	286.73	20.893	41	1.7832	47.127	0.6084	0.6277	2.4740E+06
BFE6-3A-052781-5	174.01	174.72	4038.3	287.80	6.472	73	0.9959	47.646	0.6072	0.6266	1.3772E+06
BFE6-3A-052781-6	173.85	134.74	4020.8	287.75	10.936	57	1.2903	47.446	0.6064	0.6257	1.7848E+06
BFE6-3A-052781-7	173.91	211.96	4062.0	287.96	4.348	89	0.8205	47.896	0.6087	0.6281	1.1338E+06
BFE6-3A-052781-8	173.90	98.95	3978.5	287.36	20.452	41	1.7574	47.015	0.6067	0.6260	2.4344E+06
BFE6-3A-022582-1	186.04	141.74	4058.2	289.64	11.262	61	1.3125	47.545	0.6072	0.6265	1.8066E+06
BFE6-3A-022582-2	186.32	75.81	3786.8	289.43	42.643	33	2.4577	44.392	0.6046	0.6239	3.3954E+06
BFE6-3A-022582-3	186.27	242.72	4109.0	290.19	3.775	104	0.7674	48.041	0.6101	0.6295	1.0543E+06
BFE6-3A-022582-4	186.06	77.11	3677.9	288.42	42.320	33	2.4129	43.275	0.6035	0.6228	3.3459E+06
BFE6-3A-022582-5	185.91	107.24	3939.4	289.80	20.497	46	1.7336	46.120	0.6035	0.6227	2.3886E+06
BFE6-3A-022582-6	213.74	221.33	4163.3	290.06	5.999	95	0.9657	48.701	0.6048	0.6240	1.3262E+06
BFE6-3A-022582-7	214.17	282.74	4143.3	290.20	3.760	121	0.7575	48.441	0.6010	0.6201	1.0402E+06
BFE6-3A-022582-8	213.40	118.49	4001.4	289.88	21.804	51	1.8010	46.834	0.6033	0.6225	2.4791E+06
BFE6-3A-022582-9	214.04	356.59	4155.0	290.45	2.317	152	0.6002	48.532	0.6061	0.6254	8.2362E+05

Table 4(b) (cont.). Test Number, Measured and Calculated Quantities  
Nominal 4 Inch AGA/API Orifice Meter (SI Units).

Test Identification	Test Draft (kg)	Test Draft Time (s)	Press. Note 1 (kPa)	Temp. Note 2 (K)	Diff. Press. Note 3 (kPa)	Data Samples N	Mass Flow Rate (kg/s)	Orifice Meter Density (kg/m <sup>3</sup> )	CY <sub>2</sub>	KY <sub>2</sub>	Orifice Bore Rd
BFEE-3B-022482-1	189.91	256.50	4081.1	290.28	3.582	110	0.7404	47.697	0.6063	0.6256	1.0171E+06
BFEE-3B-022482-2	189.52	109.06	3955.8	289.83	20.351	47	1.7377	46.308	0.6058	0.6251	2.3933E+06
BFEE-3B-022482-3	189.51	146.47	4026.1	289.83	11.142	63	1.2938	47.133	0.6042	0.6235	1.7805E+06
BFEE-3B-022482-4	189.68	196.88	4055.6	289.46	6.113	84	0.9634	47.546	0.6048	0.6241	1.3265E+06
BFEE-3B-022482-5	190.73	147.26	4011.8	289.75	11.153	63	1.2952	46.980	0.6055	0.6248	1.7830E+06
BFEE-3B-022482-6	190.65	198.22	4048.9	289.86	6.083	85	0.9618	47.396	0.6052	0.6255	1.3231E+06
BFEE-3B-022482-7	190.68	109.18	3949.5	289.42	20.614	47	1.7465	46.306	0.6050	0.6242	2.4080E+06
BFEE-3B-022482-8	176.03	74.11	3712.3	288.76	40.531	32	2.3753	43.624	0.6045	0.6238	3.2893E+06
BFEE-3B-022482-9	175.98	282.53	4072.4	290.18	2.464	121	0.6229	47.613	0.6156	0.6352	8.5598E+05
BFEE-4A-080681-1	177.90	95.93	4007.1	289.21	13.778	41	1.8545	47.021	0.6039	0.6357	2.2724E+06
BFEE-4A-080681-2	177.16	187.15	4115.0	290.83	3.510	80	0.9466	47.994	0.6046	0.6365	1.1540E+06
BFEE-4A-080681-3	166.28	205.47	4121.5	291.03	2.568	88	0.8093	48.033	0.6039	0.6358	9.8599E+05
BFEE-4A-080681-4	179.25	130.95	4057.1	290.61	7.432	56	1.3689	47.356	0.6048	0.6367	1.6708E+06
BFEE-4A-080681-5	179.68	74.35	3842.5	290.23	24.491	32	2.4167	44.908	0.6039	0.6358	2.9598E+06
BFEE-4A-080681-6	180.04	198.86	4117.3	290.90	3.257	85	0.9054	48.007	0.6001	0.6318	1.1035E+06
BFEE-4A-080681-7	179.87	97.80	4010.8	290.27	13.561	42	1.8391	46.875	0.6045	0.6365	2.2478E+06
BFEE-4A-080681-8	180.07	165.36	4079.4	290.61	4.660	71	1.0889	47.618	0.6059	0.6379	1.3287E+06
BFEE-4A-080681-9	179.59	224.49	4138.6	291.08	2.505	96	0.8000	48.225	0.6033	0.6352	9.7443E+05
BFEE-4A-101681-1	172.26	70.28	3871.3	288.99	24.623	30	2.4511	45.461	0.6072	0.6392	3.0099E+06
BFEE-4A-101681-2	171.89	185.27	4104.0	290.14	3.315	79	0.9278	47.991	0.6097	0.6418	1.1330E+06
BFEE-4A-101681-3	171.63	215.66	4076.0	290.26	2.464	92	0.7958	47.641	0.6088	0.6409	9.7193E+05
BFEE-4A-101681-4	171.93	70.65	3827.9	290.36	24.817	30	2.4335	44.716	0.6054	0.6374	2.9800E+06
BFEE-4A-101681-5	172.58	154.29	4038.8	290.39	5.015	66	1.1185	47.181	0.6027	0.6345	1.3662E+06
BFEE-4A-101681-6	172.28	95.02	3967.9	288.86	13.243	41	1.8131	46.623	0.6047	0.6367	2.246E+06
BFEE-4A-101681-7	178.31	128.43	4015.5	290.03	7.617	55	1.3884	46.972	0.6083	0.6405	1.6978E+06
BFEE-4A-101681-8	178.62	220.73	4056.9	290.39	2.576	94	0.8092	47.394	0.6071	0.6391	9.8820E+05
BFEE-4A-101681-9	178.48	96.09	3969.3	290.18	13.778	41	1.8574	46.404	0.6088	0.6409	2.2717E+06
BFEE-4A-101681-10	178.65	160.35	4033.6	290.16	4.933	69	1.1141	47.161	0.6053	0.6373	1.3616E+06
BFEE-4B-102281-1	172.00	94.84	3955.8	290.83	13.234	41	1.8135	46.132	0.6080	0.6402	2.2145E+06
BFEE-4B-102281-2	172.19	190.56	4086.3	290.74	3.165	82	0.9036	47.675	0.6095	0.6417	1.1019E+06
BFEE-4B-102281-3	171.45	216.21	4116.0	290.88	2.431	92	0.7930	47.997	0.6083	0.6404	9.6638E+05
BFEE-4B-102281-4	171.99	121.93	4042.9	290.18	7.736	52	1.4106	47.269	0.6111	0.6434	1.7234E+06
BFEE-4B-102281-5	162.96	67.19	3806.4	290.96	24.756	29	2.4253	44.364	0.6062	0.6383	2.9659E+06
BFEE-4B-102281-6	163.53	183.60	4102.2	290.93	3.126	79	0.8907	47.827	0.6035	0.6354	1.0856E+06
BFEE-4B-102281-7	163.08	88.74	3976.8	289.98	13.472	38	1.8377	46.529	0.6081	0.6402	2.2481E+06
BFEE-4B-102281-8	163.39	149.22	4046.8	290.70	4.731	64	1.0950	47.220	0.6069	0.6390	1.3361E+06
BFEE-4B-102281-9	163.98	198.34	4094.5	290.80	2.697	85	0.8267	47.759	0.6035	0.6354	1.0080E+06



Table 4(b) (cont.). Test Number, Measured and Calculated Quantities  
Nominal 4 Inch AGA/API Orifice Meter (SI Units).

Test Identification	Test Draft (kg)	Test Draft Time (s)	Press. Note 1 (kPa)	Temp. Note 2 (K)	Diff. Press. Note 3 (kPa)	Data Samples N	Mass Flow Rate (kg/s)	Orifice Meter Density (kg/m <sup>3</sup> )	CY <sub>2</sub>	KY <sub>2</sub>	Orifice Bore R <sub>d</sub>
BFE6-4A-102882-1	194.48	104.12	4014.2	287.32	13.754	49	1.8678	47.446	0.6061	0.6380	2.2989E+06
BFE6-4A-102882-2	194.55	214.05	4123.7	288.18	3.172	99	0.9089	48.585	0.6070	0.6389	1.1149E+06
BFE6-4A-102882-3	207.03	255.29	4121.5	288.17	2.519	118	0.8110	48.560	0.6079	0.6399	9.9483E+05
BFE6-4A-102882-4	217.44	154.52	4041.8	287.73	7.877	72	1.4072	47.700	0.6018	0.6335	1.7297E+06
BFE6-4A-102382-5	217.80	89.53	3795.3	287.91	24.925	42	2.4327	44.749	0.6038	0.6356	2.9977E+06
BFE6-4A-102882-6	217.91	229.86	4130.7	287.90	3.480	106	0.9480	48.721	0.6037	0.6354	1.1636E+06
BFE6-4A-102882-7	216.75	117.35	3997.1	287.24	13.364	55	1.8471	47.259	0.6093	0.6413	2.2743E+06
BFE6-4A-102882-8	216.86	192.24	4075.5	287.98	4.947	89	1.1280	48.053	0.6066	0.6385	1.3852E+06
BFE6-4A-102882-9	218.03	269.51	4105.4	288.42	2.508	125	0.8090	48.324	0.6092	0.6413	9.9197E+05
BFE6-4B-022582-1	213.83	115.49	4015.7	290.09	13.662	50	1.8515	46.964	0.6056	0.6375	2.2633E+06
BFE6-4B-022582-2	213.83	225.92	4122.9	290.39	3.456	97	0.9465	48.167	0.6079	0.6399	1.1547E+06
BFE6-4B-022582-3	214.07	261.35	4129.2	290.55	2.593	112	0.8191	48.211	0.6071	0.6391	9.9885E+05
BFE6-4B-022582-4	213.51	150.52	4050.8	290.14	7.828	65	1.4185	47.367	0.6104	0.6425	1.7331E+06
BFE6-4B-022582-5	213.81	90.13	3762.0	288.60	23.848	39	2.3723	44.238	0.6052	0.6370	2.9190E+06
BFE6-4B-022582-6	213.28	227.90	4063.3	290.65	3.458	97	0.9358	47.422	0.6056	0.6375	1.1418E+06
BFE6-4B-022582-7	213.66	118.63	3922.2	290.22	13.361	51	1.8011	45.845	0.6030	0.6347	2.2034E+06
BFE6-4B-022582-8	220.59	199.88	4031.5	290.31	4.769	85	1.1036	47.110	0.6101	0.6422	1.3481E+06
BFE6-4B-022582-9	220.59	284.12	4042.4	290.37	2.348	121	0.7764	47.227	0.6110	0.6432	9.4817E+05
BFE6-4B-100182-1	192.00	102.55	3988.8	287.41	13.796	48	1.8722	47.129	0.6084	0.6404	2.3041E+06
BFE6-4B-100182-2	192.65	208.34	4111.0	287.68	3.250	96	0.9247	48.528	0.6102	0.6424	1.1356E+06
BFE6-4B-100182-3	192.97	247.22	4146.6	287.74	2.318	114	0.7806	48.938	0.6074	0.6394	9.5806E+05
BFE6-4B-100182-4	192.41	135.54	4029.2	287.50	7.866	63	1.4196	47.593	0.6080	0.6400	1.7459E+06
BFE6-4B-100182-5	192.66	78.84	3767.2	287.38	25.092	37	2.4437	44.506	0.6060	0.6378	3.0157E+06
BFE6-4B-100182-6	192.87	207.51	4108.6	287.68	3.302	96	0.9295	48.499	0.6086	0.6407	1.1415E+06
BFE6-4B-100182-7	192.62	104.87	3959.4	287.69	13.413	49	1.8367	46.732	0.6079	0.6399	2.2598E+06
BFE6-4B-100182-8	193.05	169.49	4030.7	287.58	5.049	79	1.1390	47.597	0.6089	0.6409	1.4005E+06
BFE6-4B-100182-9	193.31	250.43	4100.4	287.80	2.282	115	0.7719	48.380	0.6088	0.6408	9.4780E+05
BFE5-5A-060381-1	167.48	116.51	4097.7	288.06	3.852	49	1.4375	48.300	0.6111	0.6754	1.5120E+06
BFE5-5A-060381-2	167.53	125.59	4099.7	287.92	3.323	53	1.3340	48.350	0.6103	0.6745	1.4036E+06
BFE5-5A-060381-3	167.87	68.05	3882.7	288.92	12.021	29	2.4668	45.607	0.6101	0.6743	2.5961E+06
BFE5-5A-060381-4	167.92	80.86	4005.0	287.68	8.298	34	2.0766	47.273	0.6080	0.6719	2.1888E+06
BFE5-5A-060381-5	167.71	98.96	4060.0	287.55	5.437	42	1.6947	47.948	0.6087	0.6727	1.7856E+06
BFE5-5A-060381-6	168.24	68.43	3874.3	286.94	11.957	29	2.4586	45.854	0.6089	0.6729	2.6001E+06
BFE5-5A-060381-7	167.99	145.85	4103.2	288.25	2.480	61	1.1518	48.330	0.6101	0.6743	1.2109E+06
BFE5-5A-060381-8	167.93	129.50	4083.7	288.13	3.172	54	1.2968	48.120	0.6086	0.6726	1.3640E+06
BFE5-5A-060381-9	167.78	101.93	4041.9	287.47	5.136	43	1.6460	47.749	0.6095	0.6736	1.7350E+06

Table 4(b) (cont.). Test Number, Measured and Calculated Quantities  
Nominal 4 Inch AGA/API Orifice Meter (SI Units).

Test Identification	Test Draft (kg)	Test Draft Time (s)	Press. Note 1 (kPa)	Temp. Note 2 (K)	Diff. Press. Note 3 (kPa)	Data Samples N	Mass Flow Rate (kg/s)	Orifice Meter Density (kg/m <sup>3</sup> )	CY <sub>2</sub>	KY <sub>2</sub>	Orifice Bore Rd	
BFES-5A-060481-1	154.87	63.49	3892.1	288.56	11.712	27	2.4392	45.781	0.6108	0.6750	2.5690E+06	
BFES-5A-060481-2	188.05	112.63	4068.0	288.19	5.317	47	1.6697	47.925	0.6065	0.6703	1.7564E+06	
BFES-5A-060481-3	179.58	136.80	4078.6	288.54	3.288	57	1.3127	47.986	0.6060	0.6697	1.3796E+06	
BFES-5A-060481-4	185.56	130.12	4075.5	288.18	3.878	55	1.4261	48.016	0.6060	0.6698	1.5000E+06	
BFES-5A-060481-5	185.87	89.25	3993.2	289.12	8.453	37	2.0825	46.873	0.6067	0.6704	2.1877E+06	
BFES-5A-060481-6	186.20	133.56	4072.2	288.47	3.737	56	1.3941	47.923	0.6041	0.6676	1.4654E+06	
BFES-5A-060481-7	185.49	162.06	4088.9	288.20	2.482	68	1.1446	48.170	0.6070	0.6708	1.2036E+06	
BFES-5A-060481-8	186.18	88.39	3991.6	288.93	8.571	37	2.1064	46.889	0.6093	0.6733	2.2138E+06	
BFES-5A-060481-9	186.26	140.71	4079.5	288.28	3.339	59	1.3237	48.044	0.6061	0.6698	1.3919E+06	
BFES-5A-060481-10	186.28	78.02	3873.8	288.56	11.474	33	2.3876	45.565	0.6055	0.6692	2.5152E+06	
BFES-5B-102081-1	185.21	77.08	3870.4	291.40	11.487	33	2.4028	45.037	0.6123	0.6767	2.5137E+06	
BFES-5B-102081-2	185.33	113.51	4012.0	290.07	5.029	49	1.6328	46.924	0.6161	0.6809	1.7107E+06	
BFES-5B-102081-3	185.37	143.07	4068.3	290.87	3.118	61	1.2957	47.442	0.6174	0.6824	1.3540E+06	
BFES-5B-102081-4	185.29	133.26	4058.6	290.78	3.609	57	1.3904	47.344	0.6165	0.6814	1.4536E+06	
BFES-5B-102081-5	185.52	92.03	3976.2	291.11	7.900	40	2.0159	46.321	0.6108	0.6750	2.1078E+06	
BFES-5B-102081-6	185.53	164.42	4056.2	290.73	2.431	70	1.1284	47.324	0.6097	0.6739	1.1798E+06	
BFES-5B-102081-7	185.39	131.98	4037.0	290.75	3.766	57	1.4047	47.095	0.6114	0.6757	1.4689E+06	
BFES-5B-102081-8	185.42	90.97	3978.4	290.63	8.047	39	2.0383	46.432	0.6112	0.6755	2.1336E+06	
BFES-5B-102081-9	185.52	147.21	4025.3	290.90	3.065	63	1.2602	46.933	0.6090	0.6731	1.3176E+06	
BFES-5A-052781-1	174.47	102.24	4083.5	287.40	5.509	43	1.7065	48.254	0.6072	0.6707	1.7981E+06	
BFES-5A-052781-2	174.49	142.57	4106.2	287.72	2.819	59	1.2239	48.464	0.6075	0.6711	1.2883E+06	
BFES-5A-052781-3	173.76	73.10	3925.0	287.00	11.088	31	2.3770	46.445	0.6077	0.6713	2.5119E+06	
BFES-5A-052781-4	176.10	133.67	4074.6	287.77	3.296	56	1.3174	48.079	0.6072	0.6707	1.3871E+06	
BFES-5A-052781-5	174.62	119.30	4067.0	287.81	4.073	50	1.4637	47.983	0.6074	0.6710	1.5411E+06	
BFES-5A-052781-6	174.52	84.14	3986.4	287.43	8.344	35	2.0742	47.098	0.6070	0.6705	2.1880E+06	
BFES-5A-052781-7	174.71	120.54	4065.2	287.91	3.996	50	1.4494	47.943	0.6074	0.6710	1.5257E+06	
BFES-5A-052781-8	174.60	144.49	4081.2	287.89	2.763	60	1.2084	48.138	0.6079	0.6715	1.2718E+06	
BFES-5A-052781-9	174.57	105.37	4044.3	287.22	5.234	44	1.6568	47.823	0.6075	0.6711	1.7473E+06	
BFES-5A-052781-10	174.47	71.69	3879.6	286.14	11.760	30	2.4337	46.058	0.6067	0.6702	2.5786E+06	
BFES-5A-052981-1	194.90	158.58	4048.3	287.79	2.848	67	1.2291	47.765	0.6114	0.6754	1.2944E+06	
BFES-5A-052981-2	194.27	134.55	4021.9	287.71	3.946	56	1.4439	47.467	0.6121	0.6762	1.5214E+06	
BFES-5A-052981-3	187.64	77.15	3863.2	288.32	11.844	32	2.4321	45.481	0.6079	0.6715	2.5639E+06	
BFES-5A-052981-4	187.58	154.57	4050.7	287.94	2.813	65	1.2136	47.765	0.6073	0.6709	1.2776E+06	
BFES-5A-052981-5	187.55	90.82	3973.0	288.09	8.292	38	2.0651	46.820	0.6080	0.6716	2.1753E+06	
BFES-5A-052981-6	188.04	78.29	3879.9	287.82	11.517	33	2.4018	45.766	0.6069	0.6704	2.5344E+06	
BFES-5A-052981-7	169.06	123.56	4050.0	287.98	3.607	52	1.3682	47.751	0.6048	0.6681	1.4403E+06	
BFES-5A-052981-8	168.11	99.72	4025.0	287.90	5.467	42	1.6858	47.469	0.6070	0.6706	1.7755E+06	
BFES-5A-052981-9	168.21	117.91	4046.2	287.98	3.906	50	1.4266	47.705	0.6063	0.6698	1.5018E+06	
BFES-5A-052981-10	167.94	141.45	4065.2	287.55	2.693	59	1.1873	48.009	0.6057	0.6692	1.2509E+06	
BFES-5A-052981-11	168.17	114.00	4075.1	287.61	4.116	48	1.4752	48.116	0.6081	0.6718	1.5538E+06	

Table 4(b) (cont.). Test Number, Measured and Calculated Quantities  
Nominal 4 Inch AGA/API Orifice Meter (SI Units).

Test Identification	Test Draft (kg)	Test Draft Time (s)	Press. Note 1 (kPa)	Temp. Note 2 (K)	Diff. Press. Note 3 (kPa)	Data Samples N	Mass Flow Rate (kg/s)	Orifice Meter Density (kg/m <sup>3</sup> )	CY <sub>2</sub>	KY <sub>2</sub>	Orifice Bore Rd
BFE6-5B-022482-1	207.46	150.48	4043.5	290.17	3.646	65	1.3787	47.276	0.6089	0.6727	1.4436E+06
BFE6-5B-022482-2	207.48	167.61	4034.8	290.28	2.974	72	1.2379	47.155	0.6061	0.6696	1.2960E+06
BFE6-5B-022482-3	207.53	86.13	3773.5	290.46	12.072	37	2.4095	44.063	0.6057	0.6692	2.5292E+06
BFE6-5B-022482-4	207.16	104.47	3916.9	290.94	7.888	45	1.9830	45.659	0.6059	0.6693	2.0757E+06
BFE6-5B-022482-5	210.60	129.44	3986.0	290.42	5.176	56	1.6270	46.558	0.6077	0.6714	1.7038E+06
BFE6-5B-022482-6	210.78	87.55	3752.5	290.67	12.093	38	2.4075	43.782	0.6067	0.6702	2.5265E+06
BFE6-5B-022482-7	210.80	186.14	4008.8	290.40	2.485	80	1.1325	46.828	0.6087	0.6725	1.1857E+06
BFE6-5B-022482-8	210.69	168.57	4000.8	290.25	3.048	72	1.2498	46.761	0.6071	0.6707	1.3091E+06
BFE6-5B-022482-9	210.52	129.67	3956.9	290.20	5.152	55	1.6235	46.256	0.6098	0.6737	1.7016E+06
BFE6-5B-092982-1	174.27	121.78	4028.9	288.05	3.913	57	1.4310	47.487	0.6087	0.6725	1.5063E+06
BFE6-5B-092982-2	174.13	139.50	4044.9	287.99	2.933	65	1.2483	47.688	0.6121	0.6762	1.3139E+06
BFE6-5B-092982-3	174.13	70.44	3851.8	286.43	12.028	33	2.4720	45.677	0.6116	0.6757	2.6179E+06
BFE6-5B-092982-4	173.77	86.10	3936.2	287.36	7.848	40	2.0183	46.514	0.6126	0.6768	2.1303E+06
BFE6-5B-092982-5	174.44	106.03	3985.2	287.78	5.206	50	1.6452	47.020	0.6098	0.6736	1.7338E+06
BFE6-5B-092982-6	174.13	70.74	3824.5	289.01	12.189	33	2.4615	44.906	0.6101	0.6740	2.5913E+06
BFE6-5B-092982-7	175.21	155.58	4017.4	287.92	2.382	72	1.1262	47.376	0.6148	0.6792	1.1860E+06
BFE5-6A-080681-1	183.42	110.23	4042.3	290.60	2.653	47	1.6640	47.184	0.6060	0.7293	1.5228E+06
BFE5-6A-080681-2	183.51	84.88	3952.3	290.51	4.562	37	2.1620	46.147	0.6072	0.7307	1.9811E+06
BFE5-6A-080681-3	183.55	109.16	4021.0	290.33	2.716	47	1.6815	46.984	0.6065	0.7299	1.5403E+06
BFE5-6A-080681-4	183.32	95.03	3986.3	290.37	3.630	41	1.9290	46.570	0.6046	0.7275	1.7676E+06
BFE5-6A-080681-5	183.84	74.06	3829.8	291.21	6.277	32	2.4822	44.595	0.6045	0.7275	2.2740E+06
BFE5-6A-080681-6	183.34	102.32	4011.1	290.55	3.142	44	1.7918	46.829	0.6019	0.7243	1.6406E+06
BFE5-6A-080681-7	183.59	113.18	4021.9	290.48	2.530	48	1.6221	46.969	0.6063	0.7296	1.4853E+06
BFE5-6A-080681-8	183.56	109.63	4016.0	290.26	2.719	47	1.6744	46.939	0.6040	0.7268	1.5341E+06
BFE5-6A-080681-9	183.52	85.16	3942.4	290.06	4.562	37	2.1550	46.109	0.6054	0.7286	1.9771E+06
BFE5-6B-102081-1	185.82	111.06	4054.9	290.98	2.656	48	1.6731	47.265	0.6089	0.7326	1.5300E+06
BFE5-6B-102081-2	185.71	86.81	3931.7	290.75	4.443	37	2.1393	45.864	0.6111	0.7352	1.9602E+06
BFE5-6B-102081-3	185.38	111.21	3976.6	291.51	2.713	48	1.6669	46.256	0.6068	0.7300	1.5238E+06
BFE5-6B-102081-4	185.61	97.32	3931.1	291.82	3.579	42	1.9072	45.673	0.6083	0.7318	1.7431E+06
BFE5-6B-102081-5	185.72	75.00	3789.0	291.02	6.176	33	2.4762	44.150	0.6115	0.7357	2.2713E+06
BFE5-6B-102081-6	185.62	105.65	3926.1	291.72	3.082	46	1.7570	45.632	0.6041	0.7268	1.6063E+06
BFE5-6B-102081-7	185.62	116.45	3979.2	291.25	2.477	50	1.5940	46.332	0.6068	0.7300	1.4580E+06
BFE5-6B-102081-8	185.75	96.66	3946.4	291.37	3.639	41	1.9217	45.929	0.6061	0.7292	1.7579E+06

Table 4(b) (cont.). Test Number, Measured and Calculated Quantities  
Nominal 4 Inch AGA/API Orifice Meter (SI Units).

Test Identification	Test Draft (kg)	Test Draft Time (s)	Press. Note 1 (kPa)	Temp. Note 2 (K)	Diff. Press. Note 3 (kPa)	Data Samples N	Mass Flow Rate (kg/s)	Orifice Meter Density (kg/m <sup>3</sup> )	CY <sub>2</sub>	KY <sub>2</sub>	Orifice Bore R <sub>d</sub>
BEFE6-6A-102982-1	202.70	119.19	4006.7	287.51	2.774	56	1.7006	47.324	0.6054	0.7279	1.5686E+06
BEFE6-6A-102982-2	223.94	103.67	3950.7	287.41	4.514	49	2.1602	46.678	0.6069	0.7297	1.9943E+06
BEFE6-6A-102982-3	223.70	130.10	4077.0	287.69	2.761	61	1.7195	48.123	0.6083	0.7315	1.5839E+06
BEFE6-6A-102982-4	223.78	116.00	3997.8	287.49	3.559	54	1.9291	47.223	0.6069	0.7297	1.7796E+06
BEFE6-6A-102982-5	224.20	92.26	3814.8	287.11	5.962	43	2.4301	45.118	0.6043	0.7266	2.2488E+06
BEFE6-6A-102982-6	223.96	124.01	3994.1	287.59	3.153	58	1.8059	47.160	0.6040	0.7263	1.6657E+06
BEFE6-6A-102982-7	223.59	136.96	4024.2	287.84	2.542	64	1.6325	47.472	0.6061	0.7288	1.5043E+06
BEFE6-6A-102982-8	222.77	115.81	3944.9	286.99	3.575	54	1.9235	46.684	0.6072	0.7302	1.7778E+06
BEFE6-6A-102982-9	222.91	106.12	3870.4	287.34	4.392	50	2.1006	45.738	0.6045	0.7268	1.9415E+06
BEFE6-6B-093082-1	177.13	107.05	4043.9	287.86	2.628	50	1.6547	47.700	0.6033	0.7252	1.5246E+06
BEFE6-6B-093082-2	176.88	81.56	3924.5	287.26	4.605	38	2.1687	46.395	0.6056	0.7280	2.0041E+06
BEFE6-6B-093082-3	192.10	113.42	4042.4	287.89	2.708	53	1.6937	47.677	0.6084	0.7314	1.5605E+06
BEFE6-6B-093082-4	191.96	99.54	3987.0	287.68	3.589	46	1.9285	47.059	0.6057	0.7281	1.7789E+06
BEFE6-6B-093082-5	192.71	78.88	3817.3	287.20	6.025	37	2.4431	45.133	0.6047	0.7269	2.2609E+06
BEFE6-6B-093082-6	192.66	109.30	4012.0	287.67	2.983	51	1.7627	47.356	0.6053	0.7277	1.6255E+06
BEFE6-6B-093082-7	192.30	118.44	4050.6	287.65	2.469	55	1.6236	47.818	0.6099	0.7332	1.4966E+06
BEFE6-6B-093082-8	191.91	98.36	3989.5	287.37	3.671	46	1.9511	47.144	0.6053	0.7277	1.8011E+06
BEFE6-6B-093082-9	192.19	89.42	3930.2	288.63	4.533	42	2.1492	46.218	0.6060	0.7285	1.9794E+06
BEFE6-6B-100782-1	171.22	101.69	4058.8	288.37	2.696	47	1.6837	47.783	0.6054	0.7278	1.5492E+06
BEFE6-6B-100782-2	186.08	86.50	3955.8	287.93	4.502	40	2.1512	46.644	0.6059	0.7284	1.9840E+06
BEFE6-6B-100782-3	186.00	107.54	4057.8	288.46	2.829	50	1.7296	47.756	0.6073	0.7301	1.5912E+06
BEFE6-6B-100782-4	184.63	74.30	3845.7	287.87	6.217	35	2.4849	45.352	0.6040	0.7261	2.2950E+06
BEFE6-6B-100782-5	184.30	114.27	4071.4	288.64	2.509	53	1.6128	47.882	0.6005	0.7219	1.4828E+06
BEFE6-6B-100782-6	184.16	93.77	4002.9	287.80	3.690	44	1.9640	47.226	0.6072	0.7299	1.8108E+06
BEFE6-6B-100782-7	184.04	103.76	4042.3	288.22	3.029	48	1.7737	47.615	0.6028	0.7247	1.6329E+06
BEFE6-6B-100782-8	184.00	94.66	4006.8	288.28	3.608	44	1.9438	47.185	0.6080	0.7309	1.7900E+06
BEFE6-6B-100782-9	184.05	86.01	3947.9	287.89	4.460	40	2.1398	46.559	0.6055	0.7278	1.9738E+06

Note 1: Orifice meter pressure measured at the downstream flange tap and calculated as a simple average of N data samples during Draft Time.

Note 2: Flowing gas temperature measured downstream of the meter and calculated as a simple average of N data samples taken during Draft Time.

Note 3: Differential pressure measured between the flange taps and calculated as the square of the average of the square roots of N data samples taken during Draft Time.

Table 5(a). Test Meter Identification and Physical Measurements  
Nominal 6 Inch AGA/API Orifice Meter (SI Units).

Test Identification	Test Configuration	Run Diameter (cm)	Orifice Diameter (cm)	Beta Ratio
BFE7-1A-020382-[10]	1982-B	15.4173	3.1725	0.2058
BFE7-1B-020582-[9]	1982-B	15.4173	3.1727	0.2058
BFE8-1A-012982-[8]	1982-B	15.4160	3.1725	0.2058
BFE8-1B-051282-[12]	1982-B	15.4160	3.1727	0.2058
BFE7-2A-020282-[9]	1982-B	15.4173	5.7147	0.3707
BFE7-2A-021182-[9]	1982-B	15.4173	5.7147	0.3707
BFE7-2B-020982-[10]	1982-B	15.4173	5.7150	0.3707
BFE7-2B-021082-[9]	1982-B	15.4173	5.7150	0.3707
BFE8-2A-012782-[9]	1982-B	15.4160	5.7147	0.3707
BFE7-3A-020482-[9]	1982-B	15.4173	7.6208	0.4943
BFE7-3A-021182-[9]	1982-B	15.4173	7.6208	0.4943
BFE7-3B-020382-[9]	1982-B	15.4173	7.6210	0.4943
BFE8-3A-051382-[12]	1982-B	15.4160	7.6208	0.4943
BFE8-3B-012782-[9]	1982-B	15.4160	7.6210	0.4944
BFE7-4A-020982-[9]	1982-B	15.4173	8.8885	0.5765
BFE7-4B-020482-[9]	1982-B	15.4173	8.8882	0.5765
BFE8-4A-051382-[12]	1982-B	15.4160	8.8885	0.5766
BFE8-4B-012982-[9]	1982-B	15.4160	8.8882	0.5766

Note: Test Identification bracket gives number of tests run with this geometry. A total of 172 tests were run on the nominal 6 inch run size.

Table 5(b). Test Number, Measured and Calculated Quantities  
Nominal 6 Inch AGA/API Orifice Meter (SI Units).

Test Identification	Test Draft (kg)	Test Draft Time (s)	Press. Note 1 (kPa)	Temp. Note 2 (K)	Diff. Press. Note 3 (kPa)	Data Samples N	Mass Flow Rate (kg/s)	Orifice Meter Density (kg/m <sup>3</sup> )	CY <sub>2</sub>	KY <sub>2</sub>	Orifice Bore Rd
BFEE7-1A-020382-1	194.27	307.67	4202.4	287.04	17.615	132	0.6314	49.733	0.6032	0.6037	1.3972E+06
BFEE7-1A-020382-2	194.08	327.74	4171.5	287.06	15.804	140	0.5922	49.363	0.5995	0.6000	1.3108E+06
BFEE7-1A-020382-3	193.89	231.60	4117.6	287.32	31.916	99	0.8372	48.674	0.6005	0.6010	1.8532E+06
BFEE7-1A-020382-4	193.42	189.03	4075.1	287.51	48.717	81	1.0232	48.134	0.5973	0.5979	2.2651E+06
BFEE7-1A-020382-5	193.94	312.33	4116.4	287.43	17.436	134	0.6209	48.640	0.6029	0.6034	1.3741E+06
BFEE7-1A-020382-6	193.98	277.31	4094.7	287.51	22.441	119	0.6995	48.367	0.6003	0.6009	1.5481E+06
BFEE7-1A-020382-7	194.05	338.71	4087.9	287.28	14.848	145	0.5729	48.329	0.6047	0.6053	1.2687E+06
BFEE7-1A-020382-8	194.16	284.30	4062.9	287.22	21.382	122	0.6829	48.043	0.6024	0.6030	1.5131E+06
BFEE7-1A-020382-9	194.12	402.29	4110.1	286.84	10.600	172	0.4825	48.676	0.6007	0.6012	1.0694E+06
BFEE7-1A-020382-10	193.59	186.74	4065.4	287.63	49.385	80	1.0367	47.998	0.6019	0.6025	2.2945E+06
BFEE7-1B-020582-1	172.48	235.12	4144.6	289.02	24.398	101	0.7336	48.674	0.6018	0.6023	1.6166E+06
BFEE7-1B-020582-2	172.41	200.35	4093.4	289.10	33.991	86	0.8605	48.058	0.6018	0.6023	1.8972E+06
BFEE7-1B-020582-3	172.52	301.98	4131.1	289.04	14.790	129	0.5713	48.513	0.6030	0.6035	1.2591E+06
BFEE7-1B-020582-4	172.39	168.66	4080.7	289.00	48.566	72	1.0221	47.926	0.5988	0.5993	2.2542E+06
BFEE7-1B-020582-5	172.77	269.66	4113.8	289.06	18.793	115	0.6407	48.305	0.6011	0.6016	1.4123E+06
BFEE7-1B-020582-6	151.87	149.03	4047.2	289.09	48.826	64	1.0190	47.514	0.5980	0.5985	2.2479E+06
BFEE7-1B-020582-7	169.02	271.02	4106.7	289.27	17.896	116	0.6236	48.182	0.6004	0.6010	1.3741E+06
BFEE7-1B-020582-8	168.90	198.08	4073.2	289.04	33.994	85	0.8527	47.830	0.5977	0.5982	1.8805E+06
BFEE7-1B-020582-9	169.01	332.85	4124.0	289.08	11.596	142	0.5078	48.421	0.6059	0.6065	1.1191E+06
BFEE8-1A-012982-1	196.89	320.78	4130.6	288.51	17.181	138	0.6138	48.605	0.6005	0.6010	1.3546E+06
BFEE8-1A-012982-2	196.73	236.38	4060.5	288.74	32.020	101	0.8323	47.735	0.6018	0.6023	1.8373E+06
BFEE8-1A-012982-3	196.80	346.14	4070.9	289.02	14.869	148	0.5685	47.806	0.6029	0.6035	1.2541E+06
BFEE8-1A-012982-4	196.51	197.44	3973.4	288.91	47.353	85	0.9953	46.678	0.5984	0.5990	2.1985E+06
BFEE8-1A-012982-5	196.96	312.05	4031.6	289.11	18.757	134	0.6312	47.328	0.5990	0.5995	1.3926E+06
BFEE8-1A-012982-6	196.99	290.42	4015.5	288.94	21.476	124	0.6783	47.168	0.6025	0.6030	1.4975E+06
BFEE8-1A-012982-7	195.68	348.30	4022.8	289.07	14.765	149	0.5618	47.231	0.6016	0.6021	1.2398E+06
BFEE8-1A-012982-8	195.30	277.41	4012.4	289.07	23.727	119	0.7040	47.108	0.5953	0.5958	1.5538E+06
BFEE8-1B-051282-1	201.37	196.77	4072.0	291.83	48.941	84	1.0234	47.311	0.6010	0.6016	2.2422E+06
BFEE8-1B-051282-2	201.82	249.43	4102.1	291.99	30.198	107	0.8091	47.634	0.6029	0.6035	1.7714E+06
BFEE8-1B-051282-3	201.79	374.38	4174.9	291.99	13.280	160	0.5390	48.480	0.6005	0.6010	1.1790E+06
BFEE8-1B-051282-4	201.57	285.08	4129.9	292.14	23.059	122	0.7071	47.929	0.6011	0.6017	1.5470E+06
BFEE8-1B-051282-5	201.96	326.02	4137.5	292.00	17.664	139	0.6195	48.044	0.6011	0.6016	1.3556E+06
BFEE8-1B-051282-6	201.72	195.95	4051.3	292.02	49.622	84	1.0294	47.037	0.6022	0.6027	2.2549E+06
BFEE8-1B-051282-7	202.30	368.60	4161.8	292.07	13.754	157	0.5488	48.314	0.6019	0.6024	1.2005E+06
BFEE8-1B-051282-8	202.26	331.92	4139.4	291.84	17.085	141	0.6094	48.094	0.6009	0.6014	1.3340E+06
BFEE8-1B-051282-9	190.12	351.76	4155.3	291.59	13.407	150	0.5405	48.326	0.6003	0.6008	1.1837E+06
BFEE8-1B-051282-10	189.86	272.27	4123.1	291.48	22.451	116	0.6973	47.971	0.6006	0.6011	1.5282E+06
BFEE8-1B-051282-11	190.25	235.49	4104.7	291.41	30.307	100	0.8079	47.768	0.6001	0.6006	1.7712E+06
BFEE8-1B-051282-12	190.64	386.98	4145.8	291.32	11.073	165	0.4926	48.263	0.6025	0.6030	1.0797E+06

Table 5(b) (cont.). Test Number, Measured and Calculated Quantities  
Nominal 6 Inch AGA/API Orifice Meter (SI Units).

Test Identification	Test Draft (kg)	Test Draft Time (s)	Press. Note 1 (kPa)	Temp. Note 2 (K)	Diff. Press. Note 3 (kPa)	Data Samples N	Mass Flow Rate (kg/s)	Orifice Meter Density (kg/m <sup>3</sup> )	CY <sub>2</sub>	KY <sub>2</sub>	Orifice Bore R <sub>d</sub>
BFE7-2A-020282-1	187.90	177.67	4051.0	288.53	4.794	76	1.0576	47.661	0.6043	0.6101	1.2968E+06
BFE7-2A-020282-2	188.16	243.98	4082.5	288.42	2.545	104	0.7712	48.054	0.6024	0.6082	9.4560E+05
BFE7-2A-020282-3	179.26	206.76	4063.5	288.41	3.218	89	0.8667	47.832	0.6034	0.6091	1.0629E+06
BFE7-2A-020282-4	179.26	74.81	3734.9	289.99	27.362	32	2.3962	43.687	0.5985	0.6043	2.9390E+06
BFE7-2A-020282-5	179.24	127.89	4018.1	288.82	8.596	55	1.4015	47.221	0.6008	0.6065	1.7181E+06
BFE7-2A-020282-6	163.21	91.88	3946.1	289.09	14.148	39	1.7763	46.323	0.5992	0.6050	2.1781E+06
BFE7-2A-020282-7	163.27	155.21	4010.1	289.05	4.901	66	1.0519	47.085	0.5980	0.6038	1.2890E+06
BFE7-2A-020282-8	163.40	212.76	4065.8	288.97	2.519	91	0.7680	47.757	0.6048	0.6106	9.4063E+05
BFE7-2A-020282-9	163.36	185.23	4069.0	288.96	3.352	79	0.8819	47.794	0.6019	0.6076	1.0801E+06
BFE7-2A-021182-1	189.70	202.86	4200.7	290.41	3.683	85	0.9351	49.074	0.6008	0.6066	1.1395E+06
BFE7-2A-021182-2	189.71	76.75	3886.5	292.93	27.722	32	2.4717	44.965	0.6045	0.6103	3.0052E+06
BFE7-2A-021182-3	189.31	130.63	4137.4	290.75	9.012	55	1.4492	48.271	0.6000	0.6058	1.7659E+06
BFE7-2A-021182-4	189.35	102.29	4016.5	290.57	15.225	43	1.8511	46.889	0.5983	0.6040	2.2598E+06
BFE7-2A-021182-5	189.33	253.43	4153.2	290.75	2.319	106	0.7471	48.455	0.6088	0.6146	9.1017E+05
BFE7-2A-021182-6	189.58	78.18	3776.9	289.26	27.350	33	2.4249	44.303	0.6016	0.6074	2.9780E+06
BFE7-2A-021182-7	189.01	103.30	3963.8	291.07	15.286	43	1.8298	46.184	0.5947	0.6004	2.2325E+06
BFE7-2A-021182-8	189.16	176.48	4067.7	290.47	5.037	74	1.0718	47.505	0.5984	0.6041	1.3080E+06
BFE7-2A-021182-9	189.22	138.19	4023.9	290.33	8.254	58	1.3693	47.018	0.6003	0.6060	1.6725E+06
BFE7-2B-020982-1	190.63	213.64	4194.5	290.31	3.359	91	0.8923	49.021	0.6005	0.6063	1.0877E+06
BFE7-2B-020982-2	190.82	76.58	3845.8	290.57	28.670	33	2.4917	44.890	0.5998	0.6055	3.0479E+06
BFE7-2B-020982-3	190.55	136.07	4115.4	290.33	8.420	58	1.4004	48.090	0.6009	0.6067	1.7085E+06
BFE7-2B-020982-4	190.32	102.64	4014.6	290.23	15.208	44	1.8542	46.927	0.5993	0.6051	2.2654E+06
BFE7-2B-020982-5	190.96	249.87	4160.0	290.56	2.478	107	0.7642	48.571	0.6016	0.6074	9.3138E+05
BFE7-2B-020982-6	191.05	77.93	3790.5	290.09	28.097	33	2.4516	44.323	0.5999	0.6056	3.0042E+06
BFE7-2B-020982-7	190.57	103.25	4001.3	290.56	15.227	44	1.8457	46.713	0.5976	0.6033	2.2536E+06
BFE7-2B-020982-8	190.19	172.29	4111.8	290.08	5.334	74	1.1039	48.094	0.5952	0.6009	1.3476E+06
BFE7-2B-020982-9	190.18	138.55	4072.9	289.89	8.234	59	1.3726	47.673	0.5983	0.6040	1.6773E+06
BFE7-2B-020982-10	189.95	178.32	4105.5	290.08	4.8 5	76	1.0652	48.019	0.6000	0.6058	1.3005E+06
BFE7-2B-021082-1	189.68	216.09	4131.4	290.46	3.286	93	0.8778	48.253	0.6020	0.6078	1.0704E+06
BFE7-2B-021082-2	189.55	76.85	3773.8	291.47	28.607	33	2.4665	43.898	0.6010	0.6067	3.0130E+06
BFE7-2B-021082-3	189.07	134.37	4046.9	290.06	8.613	58	1.4071	47.336	0.6018	0.6075	1.7192E+06
BFE7-2B-021082-4	189.27	104.45	3960.3	290.16	14.682	45	1.8121	46.304	0.6001	0.6059	2.2158E+06
BFE7-2B-021082-5	189.49	249.37	4091.5	290.61	2.526	107	0.7599	47.758	0.5976	0.6033	9.2669E+05
BFE7-2B-021082-6	189.60	77.50	3753.9	288.81	28.191	33	2.4465	44.108	0.5991	0.6049	3.0084E+06
BFE7-2B-021082-7	189.05	104.00	3970.6	290.19	14.994	44	1.8178	46.418	0.5950	0.6007	2.2223E+06
BFE7-2B-021082-8	189.22	173.72	4056.9	290.26	5.219	74	1.0892	47.417	0.5980	0.6037	1.3300E+06
BFE7-2B-021082-9	188.96	136.25	4027.5	290.18	8.486	58	1.3868	47.087	0.5991	0.6048	1.6943E+06





Table 5(b) (cont.). Test Number, Measured and Calculated Quantities  
Nominal 6 Inch AGA/API Orifice Meter (SI Units).

Test Identification	Test Draft (kg)	Test Draft Time (s)	Press. Note 1 (kPa)	Temp. Note 2 (K)	Diff. Press. Note 3 (kPa)	Data Samples N	Mass Flow Rate (kg/s)	Orifice Meter Density (kg/m <sup>3</sup> )	CY <sub>2</sub>	KY <sub>2</sub>	Orifice Bore R <sub>d</sub>
BFEB-3A-051382-1	190.73	116.72	4038.8	290.89	3.541	50	1.6341	47.092	0.6016	0.6204	1.4944E+06
BFEB-3A-051382-2	190.70	92.55	3967.2	290.81	5.728	40	2.0605	46.270	0.6017	0.6205	1.8863E+06
BFEB-3A-051382-3	190.85	76.47	3802.0	291.75	8.777	33	2.4958	44.181	0.6025	0.6214	2.2841E+06
BFEB-3A-051382-4	190.39	130.94	4028.8	291.46	2.812	56	1.4540	46.875	0.6021	0.6209	1.3281E+06
BFEB-3A-051382-5	204.44	115.60	3978.3	290.88	4.210	50	1.7685	46.387	0.6017	0.6205	1.6186E+06
BFEB-3A-051382-6	204.50	100.92	3932.5	290.91	5.582	43	2.0263	45.847	0.6022	0.6210	1.8554E+06
BFEB-3A-051382-7	204.84	82.66	3746.2	291.15	8.765	35	2.4781	43.628	0.6024	0.6213	2.2726E+06
BFEB-3A-051382-8	204.52	149.20	4040.6	291.36	2.521	64	1.3708	47.030	0.5985	0.6172	1.2522E+06
BFEB-3A-051382-9	204.53	137.54	4025.9	291.26	2.959	59	1.4871	46.877	0.6002	0.6190	1.3590E+06
BFEB-3A-051382-10	204.49	127.40	4020.6	291.38	3.411	55	1.6051	46.792	0.6040	0.6229	1.4665E+06
BFEB-3A-051382-11	204.50	114.14	3986.4	291.04	4.319	49	1.7917	46.454	0.6014	0.6202	1.6390E+06
BFEB-3A-051382-12	204.53	148.78	4045.6	291.38	2.459	64	1.3747	47.085	0.6074	0.6264	1.2557E+06
BFEB-3B-012782-1	192.68	140.09	4071.6	289.23	2.458	60	1.3754	47.776	0.6033	0.6222	1.2623E+06
BFEB-3B-012782-2	192.23	105.79	4007.0	289.53	4.343	45	1.8171	46.962	0.6049	0.6238	1.6678E+06
BFEB-3B-012782-3	192.61	93.83	3924.7	289.47	5.721	40	2.0528	46.005	0.6015	0.6203	1.8862E+06
BFEB-3B-012782-4	193.48	121.32	4024.1	289.64	3.375	52	1.5948	47.144	0.6010	0.6198	1.4631E+06
BFEB-3B-012782-5	192.45	78.75	3765.5	289.85	8.440	34	2.4438	44.069	0.6024	0.6212	2.2476E+06
BFEB-3B-012782-6	191.89	127.52	4026.6	289.27	2.980	55	1.5048	47.239	0.6030	0.6218	1.3816E+06
BFEB-3B-012782-7	191.93	93.33	3919.9	289.15	5.741	40	2.0565	46.005	0.6015	0.6204	1.8911E+06
BFEB-3B-012782-8	192.48	126.81	4011.4	288.98	3.022	54	1.5179	47.113	0.6048	0.6237	1.3949E+06
BFEB-3B-012782-9	192.77	141.08	4007.8	289.06	2.475	60	1.3664	47.056	0.6020	0.6208	1.2555E+06
BFEB-4A-020982-1	185.90	81.84	3889.7	290.79	3.622	35	2.2716	45.367	0.6023	0.6386	1.7847E+06
BFEB-4A-020982-2	186.26	87.38	3919.0	289.02	3.129	38	2.1316	46.018	0.6038	0.6402	1.6812E+06
BFEB-4A-020982-3	186.06	90.12	3942.5	289.86	2.930	39	2.0645	46.147	0.6036	0.6400	1.6246E+06
BFEB-4A-020982-4	173.01	76.22	3870.6	289.72	3.624	33	2.2699	45.327	0.6020	0.6383	1.7884E+06
BFEB-4A-020982-5	170.69	71.21	3799.6	289.96	4.093	30	2.3971	44.620	0.6029	0.6393	1.8935E+06
BFEB-4A-020982-6	170.89	80.52	3893.4	289.31	3.149	34	2.1223	45.665	0.6016	0.6378	1.6733E+06
BFEB-4A-020982-7	163.40	83.55	3939.1	290.70	2.680	36	1.9557	45.959	0.5990	0.6351	1.5359E+06
BFEB-4A-020982-8	163.25	84.68	3946.6	290.50	2.571	36	1.9278	46.081	0.6020	0.6383	1.5146E+06
BFEB-4A-020982-9	163.39	83.71	3933.2	290.83	2.649	36	1.9518	45.869	0.6018	0.6381	1.5325E+06
BFEB-4B-020482-1	193.16	91.31	3940.2	289.07	3.067	39	2.1155	46.259	0.6037	0.6401	1.6680E+06
BFEB-4B-020482-2	193.47	96.84	3972.1	289.10	2.696	42	1.9931	46.628	0.6043	0.6407	1.5707E+06
BFEB-4B-020482-3	193.07	100.37	3970.6	290.19	2.558	43	1.9276	46.419	0.6014	0.6376	1.5152E+06
BFEB-4B-020482-4	193.21	80.00	3760.5	288.98	4.195	34	2.4152	44.155	0.6032	0.6396	1.9087E+06
BFEB-4B-020482-5	193.25	85.75	3859.2	289.63	3.588	37	2.2537	45.208	0.6016	0.6378	1.7762E+06
BFEB-4B-020482-6	193.16	79.90	3759.7	287.95	4.207	34	2.4176	44.320	0.6019	0.6381	1.9154E+06
BFEB-4B-020482-7	193.17	93.86	3932.4	289.81	2.934	40	2.0581	46.038	0.6019	0.6382	1.6200E+06
BFEB-4B-020482-8	193.10	100.09	3940.2	290.04	2.565	43	1.9292	46.088	0.6032	0.6396	1.5176E+06
BFEB-4B-020482-9	193.07	95.47	3915.2	290.08	2.846	41	2.0223	45.787	0.6022	0.6385	1.5911E+06

Table 5(b) (cont.). Test Number, Measured and Calculated Quantities  
Nominal 6 Inch AGA/API Orifice Meter (SI Units).

Test Identification	Test Draft (kg)	Test Draft Time (s)	Press. Note 1 (kPa)	Temp. Note 2 (K)	Diff. Press. Note 3 (kPa)	Data Samples N	Mass Flow Rate (kg/s)	Orifice Meter Density (kg/m <sup>3</sup> )	CY <sub>2</sub>	KY <sub>2</sub>	Orifice Bore R <sub>d</sub>
BF8-4A-051382-1	205.10	105.64	3928.9	291.01	2.586	45	1.9415	45.787	0.6064	0.6430	1.5238E+06
BF8-4A-051382-2	204.64	100.89	3930.5	290.82	2.840	43	2.0283	45.839	0.6043	0.6407	1.5927E+06
BF8-4A-051382-3	204.95	83.62	3772.4	290.18	4.316	36	2.4509	44.096	0.6039	0.6403	1.9311E+06
BF8-4A-051382-4	204.63	105.41	3928.8	291.28	2.652	45	1.9413	45.738	0.5991	0.6353	1.5227E+06
BF8-4A-051382-5	204.54	90.86	3848.2	290.89	3.589	39	2.2511	44.865	0.6030	0.6393	1.7691E+06
BF8-4A-051382-6	204.15	96.07	3885.6	290.20	3.135	41	2.1250	45.420	0.6053	0.6418	1.6720E+06
BF8-4A-051382-7	205.06	84.44	3775.0	290.68	4.250	36	2.4285	44.043	0.6034	0.6397	1.9110E+06
BF8-4A-051382-8	204.69	92.00	3811.7	290.73	3.556	39	2.2249	44.465	0.6014	0.6376	1.7498E+06
BF8-4A-051382-9	204.76	104.64	3888.7	291.52	2.678	45	1.9568	45.229	0.6043	0.6407	1.5347E+06
BF8-4A-051382-10	204.72	98.94	3937.6	290.29	2.901	42	2.0691	46.014	0.6088	0.6455	1.6267E+06
BF8-4A-051382-11	204.63	104.93	3980.9	290.49	2.585	45	1.9502	46.487	0.6047	0.6411	1.5316E+06
BF8-4A-051382-12	204.77	96.26	3931.6	290.98	3.171	41	2.1273	45.824	0.5999	0.6361	1.6698E+06
BF8-4B-012982-1	184.43	84.90	3942.0	288.72	3.233	37	2.1723	46.341	0.6033	0.6397	1.7142E+06
BF8-4B-012982-2	184.45	92.01	3967.5	289.20	2.738	40	2.0047	46.557	0.6036	0.6399	1.5796E+06
BF8-4B-012982-3	184.30	93.74	3963.5	288.89	2.637	40	1.9661	46.564	0.6032	0.6395	1.5504E+06
BF8-4B-012982-4	184.44	75.14	3747.4	289.56	4.340	32	2.4547	43.906	0.6045	0.6409	1.9375E+06
BF8-4B-012982-5	184.49	83.05	3817.4	289.01	3.511	36	2.2215	44.823	0.6020	0.6383	1.7543E+06
BF8-4B-012982-6	188.01	77.59	3741.0	289.66	4.249	33	2.4232	43.813	0.6037	0.6401	1.9123E+06
BF8-4B-012982-7	187.79	93.75	3901.9	289.32	2.814	40	2.0031	45.764	0.6000	0.6362	1.5791E+06
BF8-4B-012982-8	187.62	97.42	3911.8	288.91	2.567	42	1.9259	45.952	0.6028	0.6391	1.5196E+06
BF8-4B-012982-9	187.53	92.67	3887.8	288.90	2.833	40	2.0237	45.670	0.6048	0.6413	1.5972E+06

Note 1: Orifice meter pressure measured at the downstream flange tap and calculated as a simple average of N data samples during Draft Time.

Note 2: Flowing gas temperature measured downstream of the meter and calculated as a simple average of N data samples taken during Draft Time.

Note 3: Differential pressure measured between the flange taps and calculated as the square of the average of the square roots of N data samples taken during Draft Time.

Table 6(a). Test Meter Identification and Physical Measurements  
Nominal 2 Inch AGA/API Orifice Meter (British Units).

Test Identification	Test Configuration	Run Diameter (inches)	Orifice Diameter (inches)	Beta Ratio
BFEL-4A-072981-[9]	1981-C	2.0677	1.1242	0.5437
BFEL-4A-050582-[9]	1981-D	2.0677	1.1242	0.5437
BFEL-4B-050682-[8]	1981-D	2.0677	1.1246	0.5439
BFE2-4A-011282-[5]	1981-D	2.0708	1.1242	0.5429
BFE2-4A-011482-[1]	1981-D	2.0708	1.1242	0.5429
BFE2-4A-011582-[9]	1981-D	2.0708	1.1242	0.5429
BFE2-4B-011482-[8]	1981-D	2.0708	1.1246	0.5431
BFEL-5A-073081-[9]	1981-C	2.0677	1.3747	0.6648
BFEL-5A-050682-[9]	1981-D	2.0677	1.3747	0.6648
BFEL-5B-111881-[9]	1981-D	2.0677	1.3746	0.6648
BFEL-5B-050582-[9]	1981-D	2.0677	1.3746	0.6648
BFE2-5A-011382-[9]	1981-D	2.0708	1.3747	0.6639
BFE2-5B-011382-[9]	1981-D	2.0708	1.3746	0.6638
BFE2-5B-011582-[9]	1981-D	2.0708	1.3746	0.6638
BFEL-6A-072981-[8]	1981-C	2.0677	1.5003	0.7256
BFEL-6A-073181-[9]	1981-C	2.0677	1.5003	0.7256
BFEL-6A-111881-[7]	1981-D	2.0677	1.5003	0.7256
BFEL-6B-073081-[9]	1981-C	2.0677	1.5002	0.7255
BFEL-6B-073181-[9]	1981-C	2.0677	1.5002	0.7255

Note: Test Identification bracket gives number of tests run with this geometry. A total of 154 tests were run on the nominal 2 inch run size.

Table 6(b). Test Number, Measured and Calculated Quantities  
Nominal 2 Inch AGA/API Orifice Meter (British Units).

Test Identification	Test Draft (lb)	Test Draft Time (s)	Press. Note 1 (psia)	Temp. Note 2 (°F)	Diff. Press. Note 3 (in H <sub>2</sub> O)	Data Samples N	Mass Flow Rate (lb/s)	Orifice Meter Density (lb/ft <sup>3</sup> )	CV <sub>2</sub>	KY <sub>2</sub>	Orifice Bore Rd
BFEL-4A-072981-1	344.21	272.39	601.96	65.99	81.95	117	1.2637	3.0083	0.6101	0.6386	1.3934E+06
BFEL-4A-072981-2	344.67	234.92	597.14	65.58	111.49	101	1.4672	2.9867	0.6094	0.6380	1.6193E+06
BFEL-4A-072981-3	343.63	208.99	594.80	65.12	139.70	89	1.6442	2.9778	0.6110	0.6396	1.8161E+06
BFEL-4A-072981-4	343.00	174.69	592.08	64.81	199.92	75	1.9635	2.9661	0.6112	0.6397	2.1702E+06
BFEL-4A-072981-5	344.31	235.79	597.21	65.61	110.13	101	1.4602	2.9868	0.6103	0.6389	1.6116E+06
BFEL-4A-072981-6	343.25	172.49	589.83	64.53	207.62	74	1.9900	2.9565	0.6088	0.6373	2.2007E+06
BFEL-4A-072981-7	344.57	278.15	597.90	65.81	79.02	119	1.2388	2.9891	0.6111	0.6396	1.3667E+06
BFEL-4A-072981-8	344.55	252.53	596.74	65.91	96.46	108	1.3644	2.9826	0.6097	0.6383	1.5053E+06
BFEL-4A-072981-9	344.71	318.20	598.51	66.09	60.48	136	1.0833	2.9903	0.6109	0.6395	1.1947E+06
BFEL-4A-050582-1	391.09	194.06	599.37	62.71	204.71	83	2.0153	3.0161	0.6148	0.6435	2.2323E+06
BFEL-4A-050582-2	337.32	277.72	601.65	62.73	74.29	119	1.2146	3.0274	0.6139	0.6426	1.3451E+06
BFEL-4A-050582-3	336.32	172.27	594.89	62.24	193.69	74	1.9523	2.9964	0.6143	0.6430	2.1646E+06
BFEL-4A-050582-4	337.60	288.09	600.55	62.66	69.44	123	1.1718	3.0223	0.6133	0.6420	1.2980E+06
BFEL-4A-050582-5	336.58	193.52	599.37	62.04	153.71	83	1.7393	3.0203	0.6119	0.6405	1.9282E+06
BFEL-4A-050582-6	337.28	247.04	598.00	62.53	94.96	106	1.3653	3.0103	0.6121	0.6407	1.5128E+06
BFEL-4A-050582-7	336.88	206.76	595.65	62.54	136.84	88	1.6293	2.9983	0.6097	0.6383	1.8057E+06
BFEL-4A-050582-8	337.28	233.53	595.98	62.20	107.53	100	1.4442	3.0022	0.6097	0.6383	1.6013E+06
BFEL-4A-050582-9	336.52	288.79	599.55	62.57	68.70	123	1.1653	3.0178	0.6135	0.6422	1.2909E+06
BFEL-4B-050682-1	396.27	336.41	600.91	61.73	69.15	144	1.1779	3.0301	0.6164	0.6453	1.3058E+06
BFEL-4B-050682-2	395.78	232.16	604.69	62.33	144.12	99	1.7048	3.0453	0.6163	0.6452	1.8878E+06
BFEL-4B-050682-3	397.03	320.14	606.66	62.13	76.25	137	1.2402	3.0566	0.6153	0.6442	1.3734E+06
BFEL-4B-050682-4	396.22	197.29	597.46	62.40	202.81	84	2.0083	3.0083	0.6158	0.6446	2.2250E+06
BFEL-4B-050682-5	396.76	303.46	600.94	62.61	85.47	130	1.3075	3.0246	0.6160	0.6448	1.4477E+06
BFEL-4B-050682-6	397.01	238.57	595.26	61.90	139.46	102	1.6641	3.0004	0.6162	0.6451	1.8452E+06
BFEL-4B-050682-7	397.25	291.62	595.36	62.26	93.80	125	1.3622	2.9986	0.6152	0.6440	1.5097E+06
BFEL-4B-050682-8	397.43	278.03	593.01	61.81	103.11	119	1.4294	2.9896	0.6172	0.6461	1.5855E+06
BFEL-4A-011282-1	340.31	168.43	587.37	61.69	210.71	72	2.0205	2.9619	0.6132	0.6417	2.2432E+06
BFEL-4A-011282-2	313.39	264.80	598.44	61.77	70.98	113	1.1835	3.0174	0.6135	0.6420	1.3126E+06
BFEL-4A-011282-3	312.41	161.27	584.53	62.08	196.92	69	1.9372	2.9451	0.6099	0.6382	2.1501E+06
BFEL-4A-011282-4	279.86	233.46	590.97	61.62	73.51	100	1.1987	2.9805	0.6141	0.6427	1.3306E+06
BFEL-4A-011282-5	302.07	186.00	585.96	61.25	137.02	80	1.6240	2.9575	0.6117	0.6401	1.8043E+06
BFEL-4A-011482-1	364.75	310.85	589.91	63.29	71.15	133	1.1734	2.9646	0.6127	0.6411	1.2997E+06

Table 6(b) (cont.). Test Number, Measured and Calculated Quantities  
Nominal 2 Inch AGA/API Orifice Meter (British Units).

Test Identification	Test Draft (lb)	Test Draft Time (s)	Press. Note 1 (psia)	Temp. Note 2 (°F)	Diff. Press. Note 3 (in H <sub>2</sub> O)	Data Samples N	Mass Flow Rate (lb/s)	Orifice Meter Density (lb/ft <sup>3</sup> )	CY <sub>2</sub>	KY <sub>2</sub>	Orifice Bore R <sub>d</sub>
BFE2-4A-011582-1	365.60	303.63	601.60	63.03	75.41	130	1.2041	3.0253	0.6045	0.6326	1.3329E+06
BFE2-4A-011582-2	365.82	216.08	595.57	62.65	146.44	93	1.6930	2.9972	0.6127	0.6412	1.8760E+06
BFE2-4A-011582-3	366.16	285.33	592.55	62.08	86.44	122	1.2833	2.9856	0.6058	0.6339	1.4234E+06
BFE2-4A-011582-4	366.63	300.64	592.98	62.05	77.10	129	1.2195	2.9879	0.6093	0.6376	1.3527E+06
BFE2-4A-011582-5	365.84	252.35	593.38	62.37	109.01	108	1.4497	2.9880	0.6095	0.6378	1.6073E+06
BFE2-4A-011582-6	366.21	226.98	592.43	61.89	135.79	97	1.6134	2.9862	0.6075	0.6358	1.7901E+06
BFE2-4A-011582-7	365.50	188.18	588.46	62.23	197.56	81	1.9423	2.9640	0.6086	0.6369	2.1547E+06
BFE2-4A-011582-8	366.70	274.28	594.52	62.32	92.23	117	1.3369	2.9941	0.6100	0.6384	1.4822E+06
BFE2-4A-011582-9	366.42	323.05	597.93	61.73	66.41	138	1.1343	3.0150	0.6078	0.6361	1.2582E+06
BFE2-4B-011482-1	365.54	304.77	596.92	64.08	72.18	131	1.1994	2.9950	0.6182	0.6470	1.3259E+06
BFE2-4B-011482-2	365.10	225.18	588.45	64.20	137.19	97	1.6214	2.9517	0.6104	0.6388	1.7933E+06
BFE2-4B-011482-4	364.70	188.84	587.60	63.63	194.82	81	1.9313	2.9509	0.6102	0.6386	2.1379E+06
BFE2-4B-011482-5	365.55	285.37	595.35	63.75	84.53	122	1.2810	2.9892	0.6106	0.6390	1.4169E+06
BFE2-4B-011482-6	365.53	230.64	591.08	63.61	131.37	99	1.5849	2.9686	0.6080	0.6363	1.7540E+06
BFE2-4B-011482-7	365.86	274.06	593.23	63.92	92.62	117	1.3350	2.9775	0.6090	0.6374	1.4766E+06
BFE2-4B-011482-8	365.58	250.06	591.51	63.62	111.22	107	1.4620	2.9706	0.6093	0.6377	1.6179E+06
BFE2-4B-011482-9	365.34	320.53	596.12	63.71	66.16	137	1.1398	2.9933	0.6138	0.6424	1.2607E+06
BFE1-5A-073081-1	379.49	126.02	587.40	64.49	184.68	54	3.0113	2.9446	0.6146	0.6852	2.7240E+06
BFE1-5A-073081-2	380.44	211.85	599.15	65.05	64.41	91	1.7958	3.0001	0.6149	0.6855	1.6217E+06
BFE1-5A-073081-3	380.04	127.15	587.80	64.47	180.07	55	2.9889	2.9467	0.6175	0.6885	2.7037E+06
BFE1-5A-073081-4	380.29	211.08	598.64	65.28	65.09	90	1.8016	2.9961	0.6140	0.6845	1.6266E+06
BFE1-5A-073081-5	380.80	271.29	602.80	65.45	39.34	116	1.4037	3.0159	0.6135	0.6839	1.2666E+06
BFE1-5A-073081-6	380.14	157.42	588.74	64.59	117.73	67	2.4148	2.9507	0.6166	0.6874	2.1839E+06
BFE1-5A-073081-7	380.15	174.07	588.47	65.08	97.59	74	2.1839	2.9463	0.6130	0.6833	1.9738E+06
BFE1-5A-073081-8	381.58	282.74	604.03	65.74	36.25	121	1.3496	3.0201	0.6140	0.6845	1.2172E+06
BFE1-5A-073081-9	312.79	276.57	604.97	65.74	25.36	118	1.1310	3.0249	0.6151	0.6857	1.0199E+06
BFE1-5A-050682-1	395.97	299.84	604.74	60.78	33.63	129	1.3206	3.0556	0.6202	0.6914	1.1988E+06
BFE1-5A-050682-2	395.19	159.66	587.36	61.08	122.47	69	2.4752	2.9657	0.6182	0.6891	2.2491E+06
BFE1-5A-050682-3	395.90	263.53	592.94	61.51	44.64	113	1.5023	2.9912	0.6189	0.6899	1.3637E+06
BFE1-5A-050682-4	395.62	124.70	574.51	60.26	205.54	53	3.1726	2.9056	0.6179	0.6889	2.8890E+06
BFE1-5A-050682-5	397.10	309.67	590.48	61.67	32.71	132	1.2823	2.9777	0.6186	0.6896	1.1640E+06
BFE1-5A-050682-6	395.86	162.57	592.68	61.55	118.32	70	2.4350	2.9896	0.6163	0.6870	2.2102E+06
BFE1-5A-050682-7	396.17	126.11	586.09	61.65	198.37	54	3.1415	2.9557	0.6175	0.6884	2.8527E+06
BFE1-5A-050682-8	397.07	208.19	598.16	61.64	72.24	89	1.9072	3.0168	0.6149	0.6855	1.7302E+06
BFE1-5A-050682-9	397.38	342.05	602.45	61.48	26.46	146	1.1618	3.0395	0.6167	0.6875	1.0538E+06

Table 6(b) (cont.). Test Number, Measured and Calculated Quantities  
Nominal 2 Inch AGA/API Orifice Meter (British Units).

Test Identification	Test Draft (lb)	Draft Time (s)	Press. Note 1 (psia)	Temp. Note 2 (°F)	Diff. Press. Note 3 (in H <sub>2</sub> O)	Data Samples N	Mass Flow Rate (lb/s)	Orifice Meter Density (lb/ft <sup>3</sup> )	CY <sub>2</sub>	KY <sub>2</sub>	Orifice Bore R <sub>d</sub>
BFEL-5B-111881-1	385.52	119.91	580.75	61.22	210.80	51	3.2150	2.9313	0.6157	0.6864	2.9227E+06
BFEL-5B-111881-2	385.22	159.44	585.21	63.07	118.97	68	2.4161	2.9424	0.6147	0.6853	2.1902E+06
BFEL-5B-111881-3	327.33	221.64	581.91	63.38	44.84	95	1.4769	2.9238	0.6141	0.6846	1.3386E+06
BFEL-5B-111881-4	317.09	243.02	578.11	63.64	35.24	104	1.3048	2.9031	0.6143	0.6848	1.1826E+06
BFEL-5B-111881-5	378.81	199.55	597.80	62.72	71.40	85	1.8983	3.0080	0.6166	0.6874	1.7198E+06
BFEL-5B-111881-6	378.05	163.19	583.26	61.67	109.26	70	2.3166	2.9412	0.6152	0.6858	2.1042E+06
BFEL-5B-111881-7	323.85	232.60	597.78	62.43	38.35	99	1.3923	3.0098	0.6170	0.6878	1.2619E+06
BFEL-5B-111881-8	354.31	113.70	575.19	61.73	199.86	49	3.1162	2.9000	0.6162	0.6869	2.8322E+06
BFEL-5B-111881-9	323.01	268.25	598.07	62.06	28.92	115	1.2041	3.0136	0.6142	0.6846	1.0918E+06
BFEL-5B-050582-1	396.30	122.96	581.84	61.32	212.20	53	3.2230	2.9362	0.6147	0.6852	2.9292E+06
BFEL-5B-050582-2	395.71	167.38	588.85	61.71	113.50	72	2.3641	2.9692	0.6130	0.6834	2.1463E+06
BFEL-5B-050582-3	396.68	257.89	596.51	62.92	46.93	110	1.5382	3.0003	0.6171	0.6880	1.3933E+06
BFEL-5B-050582-4	396.19	291.60	596.71	62.92	36.81	124	1.3587	3.0013	0.6154	0.6861	1.2307E+06
BFEL-5B-050582-5	396.03	209.97	590.85	62.12	71.48	90	1.8861	2.9767	0.6155	0.6862	1.7111E+06
BFEL-5B-050582-6	395.54	165.76	584.35	62.05	116.33	71	2.3862	2.9443	0.6138	0.6842	2.1662E+06
BFEL-5B-050582-7	396.42	300.91	591.30	62.58	34.74	128	1.3174	2.9761	0.6168	0.6876	1.1944E+06
BFEL-5B-050582-8	394.91	127.07	572.87	61.06	200.36	54	3.1078	2.8924	0.6146	0.6851	2.8276E+06
BFEL-5B-050582-9	396.33	333.15	590.03	62.14	28.52	142	1.1896	2.9725	0.6153	0.6859	1.0793E+06
BFEL-5A-011382-1	358.09	276.34	600.79	63.15	33.58	118	1.2958	3.0204	0.6129	0.6828	1.1730E+06
BFEL-5A-011382-2	357.31	145.42	592.60	62.63	123.68	62	2.4571	2.9824	0.6093	0.6788	2.2271E+06
BFEL-5A-011382-3	358.62	233.74	597.35	63.00	47.19	100	1.5343	3.0040	0.6138	0.6838	1.3895E+06
BFEL-5A-011382-4	357.68	115.36	576.73	62.56	201.19	49	3.1006	2.9027	0.6111	0.6808	2.8143E+06
BFEL-5A-011382-5	358.32	274.45	594.03	62.80	34.54	118	1.3056	2.9885	0.6121	0.6819	1.1830E+06
BFEL-5A-011382-6	357.56	151.31	582.88	63.07	116.25	65	2.3631	2.9306	0.6098	0.6793	2.1424E+06
BFEL-5A-011382-7	357.65	116.12	577.35	62.46	198.61	50	3.0800	2.9065	0.6106	0.6802	2.7959E+06
BFEL-5A-011382-8	356.21	196.11	591.92	63.02	67.33	84	1.8164	2.9765	0.6111	0.6808	1.6456E+06
BFEL-5A-011382-9	358.65	307.24	592.68	62.57	27.57	131	1.1673	2.9832	0.6134	0.6833	1.0582E+06
BFEL-5B-011382-1	359.85	114.15	581.09	64.07	207.98	49	3.1525	2.9154	0.6099	0.6794	2.8549E+06
BFEL-5B-011382-2	359.53	150.68	589.01	63.74	117.65	65	2.3861	2.9573	0.6094	0.6788	2.1604E+06
BFEL-5B-011382-3	385.43	261.37	594.41	63.90	43.97	112	1.4747	2.9835	0.6134	0.6833	1.3343E+06
BFEL-5B-011382-4	328.65	253.97	594.35	63.59	33.87	109	1.2941	2.9851	0.6132	0.6831	1.1714E+06
BFEL-5B-011382-5	357.89	193.48	590.16	63.85	70.38	83	1.8497	2.9624	0.6103	0.6798	1.6744E+06
BFEL-5B-011382-6	356.40	148.79	584.55	63.06	119.03	64	2.3953	2.9391	0.6101	0.6796	2.1715E+06
BFEL-5B-011382-7	360.17	272.01	589.63	63.31	35.55	116	1.3241	2.9631	0.6147	0.6848	1.1995E+06
BFEL-5B-011382-8	357.00	113.98	571.01	62.52	207.11	49	3.1322	2.8741	0.6115	0.6812	2.8446E+06
BFEL-5B-011382-9	359.23	322.41	590.93	63.62	25.32	138	1.1142	2.9677	0.6125	0.6823	1.0088E+06

Table 6(b) (cont.). Test Number, Measured and Calculated Quantities  
Nominal 2 Inch AGA/API Orifice Meter (British Units).

Test Identification	Test Draft (lb)	Test Draft Time (s)	Press. Note 1 (psia)	Temp. Note 2 (°F)	Diff. Press. Note 3 (in H <sub>2</sub> O)	Data Samples N	Mass Flow Rate (lb/s)	Orifice Meter Density (lb/ft <sup>3</sup> )	CY <sub>2</sub>	KY <sub>2</sub>	Orifice Bore Rd
BFE2-5B-011582-1	382.70	162.00	591.51	62.64	114.22	69	2.3623	2.9768	0.6103	0.6799	2.1416E+06
BFE2-5B-011582-2	406.14	303.80	602.02	62.77	36.03	130	1.3369	3.0290	0.6097	0.6792	1.2107E+06
BFE2-5B-011582-3	405.28	213.90	595.89	62.65	72.72	92	1.8947	2.9988	0.6112	0.6809	1.7170E+06
BFE2-5B-011582-4	404.80	170.65	587.32	62.41	115.58	73	2.3721	2.9571	0.6112	0.6809	2.1519E+06
BFE2-5B-011582-5	405.81	319.39	598.86	62.63	32.64	137	1.2706	3.0139	0.6103	0.6799	1.1512E+06
BFE2-5B-011582-6	405.39	258.79	596.68	62.85	49.92	111	1.5665	3.0016	0.6097	0.6792	1.4191E+06
BFE2-5B-011582-7	405.04	218.88	594.63	62.42	69.59	94	1.8505	2.9940	0.6108	0.6804	1.6777E+06
BFE2-5B-011582-8	404.97	128.96	576.62	62.86	206.32	55	3.1403	2.9003	0.6115	0.6812	2.8494E+06
BFE2-5B-011582-9	406.06	347.30	597.53	62.89	27.41	149	1.1692	3.0056	0.6138	0.6837	1.0591E+06
BFE1-6A-072981-1	380.21	279.02	610.75	66.58	23.15	119	1.3627	3.0484	0.6143	0.7226	1.1242E+06
BFE1-6A-072981-2	380.10	93.10	578.27	64.41	218.20	40	4.0827	2.8992	0.6147	0.7231	3.3868E+06
BFE1-6A-072981-3	380.03	219.15	600.63	66.36	37.97	94	1.7341	2.9993	0.6154	0.7239	1.4323E+06
BFE1-6A-072981-4	379.65	96.59	573.96	64.53	205.04	41	3.9306	2.8768	0.6129	0.7209	3.2612E+06
BFE1-6A-072981-5	379.74	130.29	578.44	64.92	111.45	56	2.9146	2.8970	0.6143	0.7225	2.4161E+06
BFE1-6A-072981-6	379.86	177.19	584.60	65.55	60.30	76	2.1438	2.9240	0.6115	0.7192	1.7748E+06
BFE1-6A-072981-7	380.52	290.97	603.67	65.84	21.57	124	1.3078	3.0177	0.6140	0.7222	1.0806E+06
BFE1-6A-072981-8	380.52	170.82	592.59	65.22	63.03	73	2.2276	2.9661	0.6170	0.7257	1.8438E+06
BFE1-6A-073181-1	385.48	97.07	571.37	62.51	205.89	42	3.9712	2.8760	0.6181	0.7270	3.3044E+06
BFE1-6A-073181-2	386.57	286.63	598.81	63.74	22.67	123	1.3487	3.0067	0.6187	0.7278	1.1179E+06
BFE1-6A-073181-3	385.23	128.79	584.29	62.79	113.70	55	2.9911	2.9394	0.6197	0.7289	2.4854E+06
BFE1-6A-073181-4	386.76	289.40	601.18	63.41	22.57	124	1.3364	3.0207	0.6132	0.7213	1.1080E+06
BFE1-6A-073181-5	385.14	96.70	573.36	62.10	206.75	42	3.9828	2.8885	0.6172	0.7260	3.3154E+06
BFE1-6A-073181-6	385.77	215.40	597.01	63.77	40.73	92	1.7909	2.9974	0.6139	0.7221	1.4847E+06
BFE1-6A-073181-7	385.01	169.28	594.98	62.95	65.75	72	2.2744	2.9923	0.6142	0.7224	1.8878E+06
BFE1-6A-073181-8	385.21	127.76	584.70	62.43	117.06	55	3.0151	2.9438	0.6152	0.7236	2.5065E+06
BFE1-6A-073181-9	330.53	279.89	602.94	63.33	17.49	120	1.1809	3.0301	0.6145	0.7228	9.7906E+05
BFE1-6A-111881-1	376.37	96.28	571.76	63.92	203.33	41	3.9092	2.8694	0.6129	0.7209	3.2467E+06
BFE1-6A-111881-2	381.39	270.77	596.64	64.87	25.20	116	1.4085	2.9886	0.6148	0.7231	1.1660E+06
BFE1-6A-111881-3	380.65	97.79	566.37	63.72	201.10	42	3.8925	2.8435	0.6165	0.7251	3.2351E+06
BFE1-6A-111881-4	380.96	285.58	592.79	64.28	22.66	122	1.3340	2.9729	0.6157	0.7242	1.1055E+06
BFE1-6A-111881-5	380.45	131.56	577.32	63.61	109.30	56	2.8918	2.8993	0.6152	0.7236	2.4016E+06
BFE1-6A-111881-6	381.38	230.10	589.23	64.19	35.04	98	1.6575	2.9557	0.6169	0.7256	1.3741E+06
BFE1-6A-111881-7	380.56	130.89	576.79	62.14	109.06	56	2.9075	2.9056	0.6186	0.7276	2.4194E+06

Table 6(b) (cont.). Test Number, Measured and Calculated Quantities  
Nominal 2 Inch AGA/API Orifice Meter (British Units).

Test Identification	Test Draft (lb)	Test Draft Time (s)	Press. Note 1 (psia)	Temp. Note 2 (°F)	Diff. Press. Note 3 (in H <sub>2</sub> O)	Data Samples N	Mass Flow Rate (lb/s)	Orifice Meter Density (lb/ft <sup>3</sup> )	CY <sub>2</sub>	KY <sub>2</sub>	Orifice Bore Rd
BFEL-6B-073081-1	348.61	115.06	593.48	63.91	117.06	49	3.0298	2.9788	0.6146	0.7229	2.5121E+06
BFEL-6B-073081-2	349.76	210.12	594.84	64.72	35.04	90	1.6646	2.9805	0.6173	0.7260	1.3785E+06
BFEL-6B-073081-3	349.30	117.26	583.98	62.98	116.03	50	2.9789	2.9367	0.6113	0.7189	2.4748E+06
BFEL-6B-073081-4	349.69	207.53	593.81	64.31	36.24	89	1.6850	2.9779	0.6145	0.7227	1.3963E+06
BFEL-6B-073081-5	348.47	248.10	596.09	64.27	25.13	106	1.4045	2.9896	0.6138	0.7219	1.1637E+06
BFEL-6B-073081-6	371.20	93.67	572.28	62.09	205.31	40	3.9628	2.8831	0.6170	0.7257	3.2993E+06
BFEL-6B-073081-7	371.88	168.03	588.71	63.02	63.53	72	2.2132	2.9603	0.6113	0.7190	1.8379E+06
BFEL-6B-073081-8	371.79	93.53	572.35	61.50	206.46	40	3.9750	2.8871	0.6168	0.7254	3.3121E+06
BFEL-6B-073081-9	329.27	267.96	601.52	63.98	19.08	115	1.2288	3.0188	0.6135	0.7216	1.0181E+06
BFEL-6B-073181-1	398.22	174.11	599.70	63.54	66.88	75	2.2872	3.0124	0.6104	0.7180	1.8964E+06
BFEL-6B-073181-2	401.31	132.58	591.19	62.95	116.22	57	3.0269	2.9733	0.6168	0.7255	2.5134E+06
BFEL-6B-073181-3	396.39	98.66	577.79	62.27	209.02	42	4.0177	2.9098	0.6171	0.7258	3.3427E+06
BFEL-6B-073181-4	394.19	279.01	607.03	64.00	25.21	119	1.4128	3.0464	0.6108	0.7184	1.1700E+06
BFEL-6B-073181-5	397.51	133.30	589.95	62.93	113.61	57	2.9820	2.9671	0.6152	0.7236	2.4764E+06
BFEL-6B-073181-6	401.43	273.55	606.85	63.54	27.02	117	1.4675	3.0484	0.6126	0.7205	1.2160E+06
BFEL-6B-073181-7	400.03	227.60	605.39	63.35	38.68	97	1.7576	3.0422	0.6138	0.7219	1.4569E+06
BFEL-6B-073181-8	397.43	100.44	579.50	61.18	203.28	43	3.9568	2.9252	0.6147	0.7229	3.2964E+06
BFEL-6B-073181-9	302.79	241.14	609.50	63.77	19.48	103	1.2557	3.0602	0.6162	0.7247	1.0400E+06

Note 1: Orifice meter pressure measured at the downstream flange tap and calculated as a simple average of N data samples during Draft Time.

Note 2: Flowing gas temperature measured downstream of the meter and calculated as a simple average of N data samples taken during Draft Time.

Note 3: Differential pressure measured between the flange taps and calculated as the square of the average of the square roots of N data samples taken during Draft Time.



Table 7(a). Test Meter Identification and Physical Measurements  
Nominal 3 Inch AGA/API Orifice Meter (British Units).

Test Identification	Test Configuration	Run Diameter (inches)	Orifice Diameter (inches)	Beta Ratio
BFE3-2A-011982-[8]	1982-A	3.0679	1.1250	0.3667
BFE3-2B-012182-[9]	1982-A	3.0679	1.1249	0.3667
BFE4-2A-070782-[6]	1982-A	3.0678	1.1250	0.3667
BFE4-2B-070782-[4]	1982-A	3.0678	1.1249	0.3667
BFE4-2B-070982-[9]	1982-A	3.0678	1.1249	0.3667
BFE3-3B-012282-[9]	1982-A	3.0679	1.4997	0.4888
BFE4-3A-061981-[9]	1981-B	3.0678	1.5000	0.4890
BFE4-3A-072381-[9]	1981-B	3.0678	1.5000	0.4890
BFE4-3B-061881-[9]	1981-B	3.0678	1.4997	0.4889
BFE4-3B-072281-[9]	1981-B	3.0678	1.4997	0.4889
BFE3-4B-011982-[9]	1982-A	3.0679	1.7498	0.5704
BFE3-4B-012282-[9]	1982-A	3.0679	1.7498	0.5704
BFE4-4A-061981-[9]	1981-B	3.0678	1.7503	0.5705
BFE4-4A-072181-[9]	1981-B	3.0678	1.7503	0.5705
BFE4-4B-070282-[9]	1982-A	3.0678	1.7498	0.5704
BFE3-5A-012082-[8]	1982-A	3.0679	2.0006	0.6521
BFE3-5B-012082-[9]	1982-A	3.0679	1.9998	0.6519
BFE4-5A-070282-[9]	1982-A	3.0678	2.0006	0.6521
BFE4-5B-070882-[10]	1982-A	3.0678	1.9998	0.6519
BFE3-6B-012182-[8]	1982-A	3.0679	2.2496	0.7333
BFE4-6A-061781-[9]	1981-B	3.0678	2.2492	0.7332
BFE4-6A-072281-[9]	1981-B	3.0678	2.2492	0.7332
BFE4-6B-070882-[9]	1982-A	3.0678	2.2496	0.7333

Note: Test Identification bracket gives number of tests run with this geometry. A total of 197 tests were run on the nominal 3 inch run size.

Table 7(b). Test Number, Measured and Calculated Quantities  
Nominal 3 Inch AGA/API Orifice Meter (British Units).

Test Identification	Test Draft (lb)	Test Draft Time (s)	Press. Note 1 (psia)	Temp. Note 2 (°F)	Diff. Press. Note 3 (in H <sub>2</sub> O)	Data Samples N	Mass Flow Rate (lb/s)	Orifice Meter Density (lb/ft <sup>3</sup> )	CY <sub>2</sub>	KY <sub>2</sub>	Orifice Bore Rd
BFE3-2A-011982-1	404.02	258.55	594.15	64.20	138.30	111	1.5626	2.9804	0.6043	0.6098	1.7270E+06
BFE3-2A-011982-2	403.57	216.34	589.54	64.11	197.31	93	1.8654	2.9577	0.6062	0.6118	2.0626E+06
BFE3-2A-011982-3	404.26	315.59	597.52	63.99	92.45	135	1.2810	2.9986	0.6041	0.6096	1.4157E+06
BFE3-2A-011982-4	404.00	215.03	587.14	64.94	203.77	92	1.8788	2.9405	0.6026	0.6081	2.0756E+06
BFE3-2A-011982-5	404.06	286.32	592.54	65.34	113.95	123	1.4112	2.9651	0.6028	0.6083	1.5575E+06
BFE3-2A-011982-6	389.94	250.96	591.07	65.32	138.67	107	1.5538	2.9579	0.6023	0.6079	1.7151E+06
BFE3-2A-011982-7	390.26	300.05	594.40	65.51	96.09	128	1.3006	2.9734	0.6042	0.6098	1.4349E+06
BFE3-2A-011982-8	390.38	276.19	592.20	65.50	114.72	118	1.4135	2.9624	0.6019	0.6075	1.5597E+06
BFE3-2B-012182-1	369.30	274.91	600.32	55.08	99.24	118	1.3433	3.0705	0.6044	0.6099	1.5021E+06
BFE3-2B-012182-2	368.29	246.57	593.58	55.02	123.87	106	1.4937	3.0363	0.6049	0.6104	1.6712E+06
BFE3-2B-012182-3	368.39	236.28	591.75	54.79	137.64	101	1.5591	3.0284	0.5998	0.6052	1.7453E+06
BFE3-2B-012182-4	368.93	296.40	594.03	55.47	86.34	127	1.2447	3.0356	0.6039	0.6094	1.3918E+06
BFE3-2B-012182-5	368.38	193.51	588.02	58.53	206.68	83	1.9037	2.9852	0.6019	0.6074	2.1210E+06
BFE3-2B-012182-6	367.53	260.34	594.38	59.17	112.32	111	1.4117	3.0134	0.6027	0.6083	1.5708E+06
BFE3-2B-012182-7	367.36	295.91	592.40	59.48	87.47	127	1.2414	3.0014	0.6010	0.6073	1.3809E+06
BFE3-2B-012182-8	366.93	194.89	586.00	59.35	205.94	83	1.8827	2.9697	0.5978	0.6033	2.0957E+06
BFE3-2B-012182-9	367.64	325.19	592.65	59.95	71.70	139	1.1305	2.9996	0.6055	0.6110	1.2567E+06
BFE4-2A-070782-1	371.22	228.73	595.39	59.18	148.11	80	1.6230	3.0185	0.6027	0.6082	1.8054E+06
BFE4-2A-070782-2	371.17	196.83	589.26	58.80	199.29	69	1.8857	2.9897	0.6066	0.6122	2.0999E+06
BFE4-2A-070782-3	372.53	324.82	598.44	59.46	73.95	113	1.1469	3.0322	0.6015	0.6070	1.2750E+06
BFE4-2A-070782-4	371.80	198.95	582.93	58.84	200.79	70	1.8688	2.9573	0.6022	0.6077	2.0820E+06
BFE4-2A-070782-5	371.81	249.37	594.38	59.47	126.58	87	1.4910	3.0115	0.5996	0.6051	1.6581E+06
BFE4-2A-070782-6	371.31	228.38	590.79	59.32	150.54	80	1.6258	2.9942	0.6013	0.6068	1.8089E+06
BFE4-2B-070782-1	366.35	280.70	604.70	60.26	94.01	98	1.3051	3.0588	0.6045	0.6100	1.4488E+06
BFE4-2B-070782-2	365.81	261.18	600.79	59.48	109.85	91	1.4006	3.0440	0.6015	0.6070	1.5569E+06
BFE4-2B-070782-3	370.74	221.10	598.20	58.88	158.28	77	1.6768	3.0347	0.6008	0.6063	1.8658E+06
BFE4-2B-070782-4	369.17	295.09	604.43	59.35	87.84	105	1.2510	3.0634	0.5990	0.6045	1.3904E+06
BFE4-2B-070982-2	377.83	287.91	601.78	59.77	95.35	101	1.3123	3.0472	0.6047	0.6102	1.4581E+06
BFE4-2B-070982-3	378.47	258.49	598.82	59.30	120.86	91	1.4642	3.0352	0.6003	0.6058	1.6282E+06
BFE4-2B-070982-4	378.16	240.07	598.34	59.19	139.13	84	1.5752	3.0334	0.6022	0.6077	1.7520E+06
BFE4-2B-070982-5	378.28	344.86	600.11	59.77	67.50	120	1.0969	3.0387	0.6016	0.6071	1.2189E+06
BFE4-2B-070982-6	377.29	199.34	594.00	58.16	201.89	70	1.8927	3.0180	0.6021	0.6076	2.1087E+06
BFE4-2B-070982-7	378.22	257.99	596.93	59.09	120.77	90	1.4660	3.0269	0.6021	0.6077	1.6309E+06
BFE4-2B-070982-8	376.82	322.98	598.03	59.13	76.69	113	1.1667	3.0363	0.6005	0.6060	1.2977E+06
BFE4-2B-070982-9	378.14	202.88	593.89	57.93	196.20	71	1.8638	3.0148	0.6018	0.6073	2.0774E+06
BFE4-2B-070982-10	378.75	311.84	597.97	59.01	82.90	109	1.2146	3.0328	0.6016	0.6072	1.3513E+06

Table 7(b) (cont.). Test Number, Measured and Calculated Quantities  
Nominal 3 Inch AGA/API Orifice Meter (British Units).

Test Identification	Test Draft (lb)	Test Draft Time (s)	Press. Note 1 (psia)	Temp. Note 2 (°F)	Diff. Press. Note 3 (in H <sub>2</sub> O)	Data Samples N	Mass Flow Rate (lb/s)	Orifice Meter Density (lb/ft <sup>3</sup> )	CY <sub>2</sub>	KY <sub>2</sub>	Orifice Bore K <sub>d</sub>
BFE3-3B-012282-1	398.52	248.75	596.76	60.25	43.23	107	1.6021	3.0186	0.6072	0.6253	1.3349E+06
BFE3-3B-012282-2	397.66	117.52	577.88	59.75	198.88	51	3.3838	2.9259	0.6073	0.6254	2.8256E+06
BFE3-3B-012282-3	399.95	302.51	597.53	60.15	29.20	129	1.3221	3.0231	0.6094	0.6275	1.1016E+06
BFE3-3B-012282-4	398.19	196.41	588.50	60.13	70.82	84	2.0273	2.9775	0.6044	0.6225	1.6906E+06
BFE3-3B-012282-5	398.04	117.89	574.82	60.84	199.78	51	3.3764	2.9036	0.6069	0.6250	2.8161E+06
BFE3-3B-012282-6	399.10	299.55	595.14	60.55	29.99	128	1.3323	3.0085	0.6073	0.6255	1.1098E+06
BFE3-3B-012282-7	398.90	245.78	592.92	60.34	44.99	105	1.6230	2.9985	0.6050	0.6231	1.3526E+06
BFE3-3B-012282-8	398.40	154.02	584.65	60.51	114.87	66	2.5866	2.9555	0.6078	0.6259	2.1566E+06
BFE3-3B-012282-9	399.71	335.79	594.68	60.39	23.87	144	1.1904	3.0071	0.6084	0.6266	9.9180E+05
BFE4-3A-061981-1	399.91	119.46	582.15	61.98	192.96	50	3.3476	2.9337	0.6088	0.6270	2.7857E+06
BFE4-3A-061981-2	399.39	211.12	594.38	62.55	61.48	88	1.8918	2.9919	0.6036	0.6216	1.5715E+06
BFE4-3A-061981-3	398.81	117.21	583.21	61.60	200.15	49	3.4025	2.9414	0.6068	0.6249	2.8325E+06
BFE4-3A-061981-4	399.35	146.81	589.14	61.56	126.70	61	2.7202	2.9716	0.6066	0.6247	2.2635E+06
BFE4-3A-061981-5	402.19	290.12	600.28	62.75	32.22	122	1.3863	3.0204	0.6082	0.6264	1.1507E+06
BFE4-3A-061981-6	401.26	234.91	599.07	62.30	49.31	98	1.7081	3.0171	0.6060	0.6241	1.4188E+06
BFE4-3A-061981-7	399.15	203.27	598.24	61.71	65.13	85	1.9636	3.0168	0.6062	0.6243	1.6324E+06
BFE4-3A-061981-8	401.73	290.66	601.54	62.39	31.95	122	1.3821	3.0290	0.6082	0.6263	1.1477E+06
BFE4-3A-061981-9	327.75	307.81	603.67	62.62	19.07	129	1.0648	3.0383	0.6061	0.6242	8.8373E+05
BFE4-3A-072381-1	402.10	146.96	588.45	62.84	126.48	63	2.7361	2.9601	0.6119	0.6302	2.2730E+06
BFE4-3A-072381-2	315.27	243.52	593.35	65.32	28.91	104	1.2946	2.9693	0.6049	0.6229	1.0716E+06
BFE4-3A-072381-3	392.48	195.46	591.65	64.47	69.76	84	2.0080	2.9661	0.6042	0.6222	1.6641E+06
BFE4-3A-072381-4	391.90	118.75	580.34	63.98	190.68	51	3.3002	2.9122	0.6060	0.6241	2.7393E+06
BFE4-3A-072381-5	391.78	244.99	599.81	65.31	43.29	105	1.5992	3.0018	0.6071	0.6252	1.3230E+06
BFE4-3A-072381-6	343.98	256.35	605.34	65.58	30.16	110	1.3418	3.0277	0.6078	0.6259	1.1092E+06
BFE4-3A-072381-7	402.08	150.05	592.33	64.62	121.01	64	2.6796	2.9685	0.6118	0.6300	2.2202E+06
BFE4-3A-072381-8	402.90	238.59	606.33	65.09	47.65	102	1.6887	3.0358	0.6076	0.6258	1.3967E+06
BFE4-3A-072381-9	344.71	298.20	609.03	65.74	22.13	127	1.1560	3.0452	0.6096	0.6278	9.5508E+05
BFE4-3B-061881-1	406.71	239.67	594.71	61.44	48.94	100	1.6969	3.0006	0.6063	0.6244	1.4119E+06
BFE4-3B-061881-2	405.20	150.03	590.80	60.70	124.56	63	2.7008	2.9855	0.6063	0.6244	2.2501E+06
BFE4-3B-061881-3	406.36	207.75	594.23	61.33	65.08	87	1.9560	2.9988	0.6061	0.6242	1.6277E+06
BFE4-3B-061881-4	405.12	150.92	590.84	60.06	121.75	63	2.6843	2.9897	0.6091	0.6273	2.2383E+06
BFE4-3B-061881-5	406.38	295.77	604.59	61.50	32.06	124	1.3740	3.0502	0.6016	0.6196	1.1422E+06
BFE4-3B-061881-6	406.15	118.76	584.83	59.93	199.50	50	3.4199	2.9601	0.6093	0.6274	2.8535E+06
BFE4-3B-061881-7	407.07	294.88	606.56	61.47	31.75	123	1.3805	3.0603	0.6064	0.6245	1.1474E+06
BFE4-3B-061881-8	405.88	118.14	586.77	60.30	201.84	49	3.4356	2.9676	0.6077	0.6259	2.8647E+06
BFE4-3B-061881-9	408.37	350.42	608.91	61.60	22.54	147	1.1654	3.0714	0.6066	0.6247	9.6829E+05

Table 7(b) (cont.). Test Number, Measured and Calculated Quantities  
Nominal 3 Inch AGA/API Orifice Meter (British Units).

Test Identification	Test Draft (lb)	Test Draft Time (s)	Press. Note 1 (psia)	Temp. Note 2 (°F)	Diff. Press. Note 3 (in H <sub>2</sub> O)	Data Samples N	Mass Flow Rate (lb/s)	Orifice Meter Density (lb/ft <sup>3</sup> )	CY <sub>2</sub>	KY <sub>2</sub>	Orifice Bore R <sub>d</sub>
BFE4-3B-072281-1	336.83	123.43	589.19	61.93	127.03	53	2.7289	2.9696	0.6083	0.6264	2.2701E+06
BFE4-3B-072281-2	337.67	259.42	594.35	62.97	28.85	111	1.3016	2.9890	0.6074	0.6256	1.0808E+06
BFE4-3B-072281-3	336.70	169.31	595.72	62.19	66.74	72	1.9887	3.0009	0.6084	0.6265	1.6528E+06
BFE4-3B-072281-4	336.31	97.94	581.07	61.00	203.59	42	3.4338	2.9343	0.6082	0.6264	2.8619E+06
BFE4-3B-072281-5	336.36	127.14	586.03	61.30	120.40	55	2.6456	2.9575	0.6070	0.6251	2.0323E+06
BFE4-3B-072281-6	337.37	198.81	597.68	62.58	49.18	85	1.6970	3.0083	0.6040	0.6220	1.4095E+06
BFE4-3B-072281-7	336.35	99.29	581.10	61.17	198.96	43	3.3876	2.9334	0.6070	0.6252	2.8228E+06
BFE4-3B-072281-8	336.97	258.71	601.70	62.90	28.42	111	1.3025	3.0266	0.6081	0.6263	1.0810E+06
BFE4-3B-072281-9	273.63	230.93	603.39	62.32	23.60	99	1.1849	3.0388	0.6060	0.6241	9.8402E+05
BFE3-4B-011982-1	390.18	83.99	558.34	63.92	201.82	36	4.6455	2.8019	0.6050	0.6397	3.3116E+06
BFE3-4B-011982-2	389.93	215.14	592.25	64.89	28.57	92	1.8125	2.9665	0.6097	0.6448	1.2869E+06
BFE3-4B-011982-3	388.83	115.77	577.97	64.14	101.87	50	3.3586	2.8993	0.6052	0.6400	2.3898E+06
BFE3-4B-011982-4	390.61	213.24	586.74	64.47	29.84	91	1.8318	2.9414	0.6055	0.6403	1.3019E+06
BFE3-4B-011982-5	390.61	286.33	592.53	64.49	16.24	123	1.3642	2.9703	0.6083	0.6433	9.6908E+05
BFE3-4B-011982-6	389.39	83.62	554.01	62.01	202.21	36	4.6567	2.7913	0.6070	0.6419	3.3292E+06
BFE3-4B-011982-7	390.30	160.29	581.67	64.41	53.51	69	2.4349	2.9163	0.6036	0.6383	1.7314E+06
BFE3-4B-011982-8	389.79	159.01	581.26	64.31	53.96	68	2.4514	2.9148	0.6053	0.6401	1.7434E+06
BFE3-4B-011982-9	389.21	339.96	594.91	64.00	11.34	145	1.1449	2.9854	0.6097	0.6448	8.1365E+05
BFE3-4B-012282-1	396.84	83.13	558.94	60.49	208.87	36	4.7738	2.8252	0.6086	0.6436	3.4185E+06
BFE3-4B-012282-2	397.01	221.87	592.67	61.14	27.48	95	1.7894	2.9922	0.6111	0.6462	1.2768E+06
BFE3-4B-012282-3	398.91	118.22	577.82	61.03	101.11	51	3.3743	2.9177	0.6084	0.6434	2.4109E+06
BFE3-4B-012282-4	397.45	225.10	588.52	61.15	26.87	97	1.7657	2.9711	0.6120	0.6472	1.2602E+06
BFE3-4B-012282-5	399.05	273.64	594.63	60.96	18.13	117	1.4583	3.0032	0.6120	0.6472	1.0406E+06
BFE3-4B-012282-6	397.91	86.88	555.88	60.96	195.21	37	4.5800	2.8069	0.6059	0.6408	3.2785E+06
BFE3-4B-012282-7	398.24	164.37	579.29	61.49	52.49	70	2.4228	2.9222	0.6058	0.6406	1.7298E+06
BFE3-4B-012282-8	398.10	163.54	579.29	60.54	52.91	70	2.4343	2.9281	0.6056	0.6405	1.7402E+06
BFE3-4B-012282-9	399.18	359.22	594.53	60.94	10.43	154	1.1112	3.0028	0.6152	0.6506	7.9297E+05
BFE4-4A-061981-1	409.28	279.94	587.29	61.93	18.44	117	1.4620	2.9600	0.6126	0.6479	1.0422E+06
BFE4-4A-061981-2	406.85	85.99	566.63	57.91	200.94	36	4.7314	2.8800	0.6087	0.6438	3.3968E+06
BFE4-4A-061981-3	406.42	218.67	597.08	61.34	29.86	91	1.8586	3.0132	0.6064	0.6414	1.3249E+06
BFE4-4A-061981-4	406.31	121.69	588.39	60.17	95.41	51	3.3389	2.9766	0.6132	0.6485	2.3856E+06
BFE4-4A-061981-5	406.69	167.73	591.57	61.22	50.42	70	2.4247	2.9861	0.6116	0.6468	1.7295E+06
BFE4-4A-061981-6	407.20	84.74	568.99	61.54	206.22	36	4.8052	2.8698	0.6113	0.6465	3.4324E+06
BFE4-4A-061981-7	406.72	123.98	586.07	60.83	94.31	52	3.2805	2.9607	0.6076	0.6426	2.3423E+06
BFE4-4A-061981-8	408.00	270.95	601.96	61.91	19.22	113	1.5058	3.0343	0.6103	0.6454	1.0722E+06
BFE4-4A-061981-9	344.24	285.95	603.47	62.25	12.19	120	1.2039	3.0397	0.6122	0.6475	8.5671E+05

Table 7(b) (cont.). Test Number, Measured and Calculated Quantities  
Nominal 3 Inch AGA/API Orifice Meter (British Units).

Test Identification	Test Draft (lb)	Test Draft Time (s)	Press. Note 1 (psia)	Temp. Note 2 (°F)	Diff. Press. Note 3 (in H <sub>2</sub> O)	Data Samples N	Mass Flow Rate (lb/s)	Orifice Meter Density (lb/ft <sup>3</sup> )	CY <sub>2</sub>	KY <sub>2</sub>	Orifice Bore R <sub>d</sub>
BFE4-4A-072181-1	363.74	144.03	592.33	61.77	54.30	62	2.5255	2.9865	0.6138	0.6491	1.8000E+06
BFE4-4A-072181-2	363.76	75.81	570.24	61.76	206.39	33	4.7983	2.8748	0.6096	0.6447	3.4261E+06
BFE4-4A-072181-3	363.40	236.09	604.53	63.28	20.05	101	1.5393	3.0384	0.6103	0.6455	1.0938E+06
BFE4-4A-072181-4	363.57	182.02	599.10	62.44	33.92	78	1.9974	3.0164	0.6111	0.6463	1.4216E+06
BFE4-4A-072181-5	363.52	107.01	584.27	61.47	100.26	46	3.3970	2.9476	0.6116	0.6468	2.4238E+06
BFE4-4A-072181-6	363.90	76.10	565.88	60.07	204.44	33	4.7818	2.8630	0.6117	0.6469	3.4233E+06
BFE4-4A-072181-7	364.27	245.34	600.60	62.85	18.85	105	1.4847	3.0213	0.6090	0.6440	1.0560E+06
BFE4-4A-072181-8	350.22	141.71	590.01	61.73	52.51	61	2.4714	2.9749	0.6119	0.6472	1.7619E+06
BFE4-4A-072181-9	280.82	254.03	593.89	63.52	10.41	109	1.1054	2.9833	0.6146	0.6500	7.8597E+05
BFE4-4B-070282-1	385.47	78.47	567.39	57.31	214.18	30	4.9124	2.8876	0.6118	0.6470	3.5303E+06
BFE4-4B-070282-2	373.08	192.27	613.85	58.71	31.51	71	1.9404	3.1155	0.6065	0.6414	1.3865E+06
BFE4-4B-070282-3	372.38	106.02	597.96	57.93	105.68	40	3.5124	3.0396	0.6069	0.6418	2.5157E+06
BFE4-4B-070282-4	373.63	197.49	608.35	58.92	30.16	73	1.8919	3.0861	0.6074	0.6423	1.3521E+06
BFE4-4B-070282-5	374.40	250.84	607.21	59.14	18.71	92	1.4926	3.0789	0.6091	0.6441	1.0665E+06
BFE4-4B-070282-6	373.28	77.89	561.72	57.74	208.60	29	4.7924	2.8560	0.6081	0.6431	3.4437E+06
BFE4-4B-070282-7	372.47	151.19	593.11	57.95	53.74	56	2.4636	3.0148	0.5994	0.6339	1.7652E+06
BFE4-4B-070282-8	372.40	148.13	592.93	58.27	54.57	55	2.5140	3.0119	0.6073	0.6422	1.8006E+06
BFE4-4B-070282-9	373.01	204.35	593.41	58.90	29.01	76	1.8253	3.0103	0.6050	0.6398	1.3062E+06
BFE3-5A-012082-1	386.19	135.20	585.79	63.62	38.79	58	2.8564	2.9419	0.6063	0.6699	1.7777E+06
BFE3-5A-012082-2	386.79	73.35	543.62	64.86	141.91	32	5.2733	2.7224	0.6083	0.6721	3.2876E+06
BFE3-5A-012082-3	386.40	259.23	601.68	64.87	10.13	111	1.4906	3.0139	0.6118	0.6759	9.2498E+05
BFE3-5A-012082-4	395.45	136.29	585.93	63.23	39.60	59	2.9015	2.9450	0.6092	0.6731	1.8067E+06
BFE3-5A-012082-5	396.02	176.11	590.57	64.29	23.00	76	2.2487	2.9617	0.6177	0.6825	1.3978E+06
BFE3-5A-012082-6	396.40	74.26	544.12	65.52	145.23	32	5.3380	2.7212	0.6088	0.6726	3.3250E+06
BFE3-5A-012082-7	396.61	216.71	596.00	65.10	15.08	93	1.8302	2.9840	0.6186	0.6835	1.1359E+06
BFE3-5A-012082-8	396.63	266.85	597.38	64.69	10.16	114	1.4863	2.9934	0.6109	0.6750	9.2288E+05
BFE3-5B-012082-1	404.34	229.65	592.12	64.97	14.42	98	1.7607	2.9653	0.6112	0.6752	1.0937E+06
BFE3-5B-012082-2	403.53	141.24	581.23	64.77	38.77	61	2.8571	2.9119	0.6102	0.6741	1.7768E+06
BFE3-5B-012082-3	405.37	280.50	586.26	64.76	9.94	120	1.4452	2.9372	0.6072	0.6707	8.9841E+05
BFE3-5B-012082-4	404.01	103.46	567.55	64.04	74.91	44	3.9050	2.8475	0.6068	0.6703	2.4335E+06
BFE3-5B-012082-5	403.90	186.72	579.65	64.64	22.54	80	2.1631	2.9047	0.6068	0.6703	1.3457E+06
BFE3-5B-012082-6	394.49	76.04	535.05	60.73	138.88	33	5.1880	2.7027	0.6078	0.6714	3.2560E+06
BFE3-5B-012082-7	386.68	175.12	575.04	64.44	23.65	77	2.2081	2.8828	0.6069	0.6705	1.3745E+06
BFE3-5B-012082-8	375.19	129.73	575.01	64.59	40.57	57	2.8920	2.8817	0.6071	0.6706	1.7999E+06
BFE3-5B-012082-9	375.89	216.52	585.14	64.70	14.17	95	1.7361	2.9320	0.6112	0.6752	1.0794E+06

Table 7(b) (cont.). Test Number, Measured and Calculated Quantities  
Nominal 3 Inch AGA/API Orifice Meter (British Units).

Test Identification	Test Draft (lb)	Test Draft Time (s)	Press. Note 1 (psia)	Temp. Note 2 (°F)	Diff. Press. Note 3 (in H <sub>2</sub> O)	Data Samples N	Mass Flow Rate (lb/s)	Orifice Meter Density (lb/ft <sup>3</sup> )	CY <sub>2</sub>	KY <sub>2</sub>	Orifice Bore Rd
BFE4-5A-070282-1	383.18	131.76	588.47	57.81	38.74	48	2.9081	2.9921	0.6125	0.6767	1.8236E+06
BFE4-5A-070282-2	384.29	71.46	545.09	56.25	142.13	26	5.3777	2.7799	0.6135	0.6778	3.3913E+06
BFE4-5A-070282-3	384.77	247.53	598.02	59.17	11.02	88	1.5545	3.0319	0.6100	0.6740	9.7219E+05
BFE4-5A-070282-4	383.59	127.80	589.50	57.85	41.67	47	3.0015	2.9971	0.6090	0.6729	1.8818E+06
BFE4-5A-070282-5	384.31	175.91	593.45	58.57	22.12	65	2.1847	3.0126	0.6069	0.6706	1.3679E+06
BFE4-5A-070282-6	384.80	71.88	544.46	55.44	141.91	27	5.3533	2.7815	0.6110	0.6751	3.3799E+06
BFE4-5A-070282-7	385.51	206.21	595.74	59.00	15.86	76	1.8695	3.0215	0.6123	0.6766	1.1697E+06
BFE4-5A-070282-8	385.47	247.18	594.34	59.30	11.11	91	1.5595	3.0124	0.6111	0.6752	9.7546E+05
BFE4-5A-070282-9	384.14	94.67	573.90	58.44	78.57	36	4.0577	2.9138	0.6081	0.6719	2.5453E+06
BFE4-5B-070882-1	365.17	195.21	610.11	59.52	15.77	66	1.8706	3.0911	0.6082	0.6719	1.1687E+06
BFE4-5B-070882-2	378.49	124.60	600.89	57.99	42.02	44	3.0376	3.0542	0.6086	0.6724	1.9031E+06
BFE4-5B-070882-3	378.17	247.74	612.12	59.52	10.38	87	1.5265	3.1013	0.6108	0.6747	9.5351E+05
BFE4-5B-070882-4	379.04	90.14	591.36	57.90	79.65	32	4.2050	3.0062	0.6169	0.6814	2.6369E+06
BFE4-5B-070882-5	378.43	166.45	609.95	58.30	23.43	58	2.2735	3.0984	0.6056	0.6690	1.4227E+06
BFE4-5B-070882-6	378.10	69.41	555.55	58.43	145.50	25	5.4473	2.8203	0.6103	0.6742	3.4236E+06
BFE4-5B-070882-7	378.90	165.81	600.58	58.28	24.20	58	2.2851	3.0508	0.6036	0.6668	1.4311E+06
BFE4-5B-070882-8	378.62	125.43	592.82	57.89	41.89	44	3.0186	3.0137	0.6098	0.6736	1.8927E+06
BFE4-5B-070882-9	379.41	205.82	597.35	59.01	15.48	72	1.8434	3.0296	0.6111	0.6750	1.1537E+06
BFE4-5B-070882-10	359.67	194.53	598.14	59.09	15.43	68	1.8489	3.0331	0.6135	0.6778	1.1569E+06
BFE3-6B-012182-3	398.05	74.69	539.49	57.78	78.23	32	5.3294	2.7423	0.6079	0.7210	2.9840E+06
BFE3-6B-012182-4	398.01	148.77	579.41	60.19	18.49	64	2.6753	2.9310	0.6070	0.7200	1.4883E+06
BFE3-6B-012182-5	397.83	120.63	576.07	60.11	28.20	52	3.2979	2.9145	0.6077	0.7208	1.8353E+06
BFE3-6B-012182-6	398.34	75.41	538.71	57.22	77.04	32	5.2824	2.7416	0.6073	0.7202	2.9602E+06
BFE3-6B-012182-7	398.68	178.59	582.11	60.71	12.79	77	2.2324	2.9414	0.6080	0.7211	1.2407E+06
BFE3-6B-012182-8	398.10	152.86	581.54	60.52	17.42	65	2.6044	2.9397	0.6079	0.7210	1.4479E+06
BFE3-6B-012182-9	398.57	97.93	567.22	61.22	43.86	42	4.0700	2.8628	0.6067	0.7196	2.2632E+06
BFE3-6B-012182-10	398.33	199.06	582.57	60.11	10.21	85	2.0011	2.9474	0.6093	0.7227	1.1130E+06
BFE4-6A-061781-1	402.30	75.05	553.26	61.51	77.50	32	5.3605	2.7904	0.6092	0.7225	2.9836E+06
BFE4-6A-061781-2	348.09	105.09	580.29	61.79	28.21	44	3.3123	2.9254	0.6094	0.7227	1.8389E+06
BFE4-6A-061781-3	347.55	159.76	583.00	62.14	12.19	67	2.1755	2.9370	0.6079	0.7208	1.2069E+06
BFE4-6A-061781-4	406.24	119.30	593.09	61.66	29.19	50	3.4052	2.9910	0.6090	0.7223	1.8888E+06
BFE4-6A-061781-5	406.23	91.79	581.06	61.55	50.54	38	4.4256	2.9308	0.6077	0.7207	2.4576E+06
BFE4-6A-061781-6	406.33	143.54	591.08	61.52	20.48	60	2.8308	2.9817	0.6054	0.7179	1.5708E+06
BFE4-6A-061781-7	406.71	198.69	589.23	61.52	10.60	83	2.0470	2.9723	0.6095	0.7228	1.1360E+06
BFE4-6A-061781-8	406.43	171.96	597.64	61.43	13.89	72	2.3635	3.0155	0.6104	0.7239	1.3109E+06
BFE4-6A-061781-9	406.20	139.61	593.20	61.16	21.43	59	2.9095	2.9948	0.6071	0.7199	1.6149E+06

Table 7(b) (cont.), Test Number, Measured and Calculated Quantities  
Nominal 3 Inch AGA/API Orifice Meter (British Units).

Test Identification	Test Draft (lb)	Test Draft Time (s)	Press. Note 1 (psia)	Temp. Note 2 (°F)	Diff. Press. Note 3 (in H <sub>2</sub> O)	Data Samples N	Mass Flow Rate (lb/s)	Orifice Meter Density (lb/ft <sup>3</sup> )	CY <sub>2</sub>	KY <sub>2</sub>	Orifice Bore R <sub>d</sub>
BFE4-6A-072281-1	394.58	175.63	598.16	61.80	12.56	75	2.2466	3.0157	0.6102	0.7237	1.2454E+06
BFE4-6A-072281-2	389.05	88.17	584.27	61.24	49.97	38	4.4125	2.9490	0.6075	0.7204	2.4507E+06
BFE4-6A-072281-3	389.05	194.07	605.60	62.45	10.05	83	2.0047	3.0491	0.6051	0.7176	1.1097E+06
BFE4-6A-072281-4	388.98	136.99	594.08	61.61	20.21	59	2.8395	2.9963	0.6099	0.7232	1.5750E+06
BFE4-6A-072281-5	389.76	174.20	595.54	61.86	12.56	75	2.2374	3.0021	0.6090	0.7222	1.2405E+06
BFE4-6A-072281-6	390.67	72.43	562.33	60.30	77.00	31	5.3937	2.8436	0.6092	0.7225	3.0048E+06
BFE4-6A-072281-7	389.81	111.95	593.76	61.73	30.84	48	3.4820	2.9939	0.6056	0.7182	1.9311E+06
BFE4-6A-072281-8	389.92	195.61	602.40	62.73	9.98	84	1.9933	3.0312	0.6057	0.7183	1.1033E+06
BFE4-6A-072281-9	390.93	72.79	561.37	61.55	77.31	31	5.3707	2.8312	0.6067	0.7195	2.9872E+06
BFE4-6B-070882-1	350.89	167.90	595.05	58.85	10.83	63	2.0899	3.0189	0.6105	0.7241	1.1631E+06
BFE4-6B-070882-2	370.04	159.94	592.64	58.44	13.42	60	2.3136	3.0093	0.6081	0.7212	1.2886E+06
BFE4-6B-070882-3	370.63	68.05	548.82	55.96	78.55	26	5.4465	2.8007	0.6135	0.7276	3.0548E+06
BFE4-6B-070882-4	369.21	140.14	588.41	58.24	18.08	53	2.6346	2.9890	0.5987	0.7101	1.4683E+06
BFE4-6B-070882-5	371.09	111.94	583.41	57.18	27.80	42	3.3151	2.9702	0.6095	0.7229	1.8510E+06
BFE4-6B-070882-6	365.68	68.60	544.49	54.36	76.94	26	5.3306	2.7881	0.6080	0.7212	2.9973E+06
BFE4-6B-070882-7	370.35	162.20	591.95	58.83	13.12	61	2.2833	3.0032	0.6076	0.7206	1.2712E+06
BFE4-6B-070882-8	370.35	137.91	586.48	58.29	18.60	52	2.6854	2.9789	0.6027	0.7148	1.4968E+06
BFE4-6B-070882-9	368.44	88.13	571.55	57.46	45.77	33	4.1806	2.9079	0.6054	0.7180	2.3357E+06

Note 1: Orifice meter pressure measured at the downstream flange tap and calculated as a simple average of N data samples during Draft Time.

Note 2: Flowing gas temperature measured downstream of the meter and calculated as a simple average of N data samples taken during Draft Time.

Note 3: Differential pressure measured between the flange taps and calculated as the square of the average of the square roots of N data samples taken during Draft Time.

Table 8(a). Test Meter Identification and Physical Measurements  
Nominal 4 Inch AGA/API Orifice Meter (British Units).

Test Identification	Test Configuration	Run Diameter (inches)	Orifice Diameter (inches)	Beta Ratio
BFE5-2A-060281-[9]	1981-A	4.0223	1.4993	0.3728
BFE5-2A-060581-[9]	1981-A	4.0223	1.4993	0.3728
BFE5-2A-080481-[7]	1981-A	4.0223	1.4993	0.3728
BFE5-2A-080581-[7]	1981-A	4.0223	1.4993	0.3728
BFE5-2B-060481-[10]	1981-A	4.0223	1.4996	0.3728
BFE5-2B-080581-[9]	1981-A	4.0223	1.4996	0.3728
BFE5-2B-101581-[9]	1981-A	4.0223	1.4996	0.3728
BFE6-2A-052181-[11]	1981-A	4.0260	1.4993	0.3724
BFE6-2B-052281-[10]	1981-A	4.0260	1.4996	0.3725
BFE6-2B-052881-[8]	1981-A	4.0260	1.4996	0.3725
BFE5-3A-060281-[9]	1981-A	4.0223	1.9990	0.4970
BFE5-3B-111281-[9]	1981-A	4.0223	1.9992	0.4970
BFE6-3A-051481-[10]	1981-A	4.0260	1.9990	0.4965
BFE6-3A-051581-[9]	1981-A	4.0260	1.9990	0.4965
BFE6-3A-052781-[8]	1981-A	4.0260	1.9990	0.4965
BFE6-3A-022582-[9]	1981-A	4.0260	1.9990	0.4965
BFE6-3B-022482-[9]	1981-A	4.0260	1.9992	0.4966
BFE5-4A-080681-[9]	1981-A	4.0223	2.2491	0.5592
BFE5-4A-101681-[10]	1981-A	4.0223	2.2491	0.5592
BFE5-4B-102281-[9]	1981-A	4.0223	2.2495	0.5593
BFE6-4A-102882-[9]	1981-A	4.0260	2.2491	0.5586
BFE6-4B-022582-[9]	1981-A	4.0260	2.2495	0.5587
BFE6-4B-100182-[9]	1981-A	4.0260	2.2495	0.5587
BFE5-5A-060381-[9]	1981-A	4.0223	2.6244	0.6525
BFE5-5A-060481-[10]	1981-A	4.0223	2.6244	0.6525
BFE5-5B-102081-[9]	1981-A	4.0223	2.6248	0.6526
BFE6-5A-052781-[10]	1981-A	4.0260	2.6244	0.6519
BFE6-5A-052981-[11]	1981-A	4.0260	2.6244	0.6519
BFE6-5B-022482-[9]	1981-A	4.0260	2.6248	0.6520
BFE6-5B-092982-[7]	1981-A	4.0260	2.6248	0.6520
BFE5-6A-080681-[9]	1981-A	4.0223	3.0001	0.7459
BFE5-6B-102081-[8]	1981-A	4.0223	2.9993	0.7457
BFE6-6A-102982-[9]	1981-A	4.0260	3.0001	0.7452
BFE6-6B-093082-[9]	1981-A	4.0260	2.9993	0.7450
BFE6-6B-100782-[9]	1981-A	4.0260	2.9993	0.7450

Note: Test Identification bracket gives number of tests run with this geometry. A total of 316 tests were run on the nominal 4 inch run size.



Table 8(b). Test Number, Measured and Calculated Quantities  
Nominal 4 Inch AGA/API Orifice Meter (British Units).

Test Identification	Test Draft (lb)	Test Draft Time (s)	Press. Note 1 (psia)	Temp. Note 2 (°F)	Diff. Press. Note 3 (in H <sub>2</sub> O)	Data Samples N	Mass Flow Rate (lb/s)	Orifice Meter Density (lb/ft <sup>3</sup> )	CY <sub>2</sub>	KY <sub>2</sub>	Orifice Bore Rd
BFE5-2A-060281-1	370.46	229.28	599.00	59.30	46.47	96	1.6157	3.0361	0.6010	0.6069	1.3481E+06
BFE5-2A-060281-2	370.17	106.17	585.96	59.09	215.71	45	3.4865	2.9711	0.6084	0.6143	2.9129E+06
BFE5-2A-060281-3	370.17	150.52	593.19	58.79	107.81	63	2.4593	3.0098	0.6032	0.6047	2.0542E+06
BFE5-2A-060281-4	370.13	179.42	600.25	58.78	76.05	75	2.0629	3.0459	0.5988	0.6047	1.7222E+06
BFE5-2A-060281-5	370.52	108.98	585.91	58.21	208.02	46	3.3999	2.9764	0.6036	0.6095	2.8438E+06
BFE5-2A-060281-6	370.80	151.32	592.52	58.56	107.27	64	2.4505	3.0079	0.6028	0.6087	2.0476E+06
BFE5-2A-060281-7	315.14	226.46	605.39	59.39	34.27	95	1.3916	3.0680	0.5996	0.6054	1.1603E+06
BFE5-2A-060281-8	341.32	170.37	602.55	58.43	71.19	71	2.0034	3.0598	0.5997	0.6056	1.6729E+06
BFE5-2A-060281-9	312.26	268.56	605.78	59.60	23.90	112	1.1627	3.0686	0.6002	0.6060	9.6915E+05
BFE5-2A-060581-1	396.10	250.50	597.11	59.96	44.43	105	1.5812	3.0222	0.6029	0.6088	1.3183E+06
BFE5-2A-060581-2	395.73	287.35	603.05	59.99	33.82	120	1.3772	3.0522	0.5989	0.6047	1.1476E+06
BFE5-2A-060581-3	395.81	115.44	582.43	58.75	212.04	48	3.4287	2.9553	0.6051	0.6110	2.8667E+06
BFE5-2A-060581-4	395.60	160.15	589.27	58.97	109.46	67	2.4702	2.9887	0.6033	0.6092	2.0635E+06
BFE5-2A-060581-5	394.98	115.01	581.60	59.68	214.71	48	3.4343	2.9452	0.6033	0.6092	2.8680E+06
BFE5-2A-060581-6	394.63	196.75	598.86	59.41	72.09	83	2.0058	3.0347	0.5991	0.6050	1.6732E+06
BFE5-2A-060581-7	391.20	236.45	600.87	59.62	48.53	99	1.6545	3.0436	0.6014	0.6073	1.3796E+06
BFE5-2A-060581-8	391.31	156.46	588.18	58.89	111.51	66	2.5010	2.9837	0.6057	0.6117	2.0896E+06
BFE5-2A-060581-9	393.36	363.54	600.98	61.97	20.88	152	1.0820	3.0289	0.6013	0.6071	8.9942E+05
BFE5-2A-080481-1	390.37	244.69	603.27	64.54	45.80	105	1.5954	3.0240	0.5989	0.6048	1.3214E+06
BFE5-2A-080481-2	389.53	117.32	581.88	62.69	203.90	50	3.3202	2.9279	0.6003	0.6061	2.7616E+06
BFE5-2A-080481-3	390.09	162.82	588.88	63.57	104.67	70	2.3958	2.9577	0.6016	0.6075	1.9893E+06
BFE5-2A-080481-4	390.90	196.92	592.67	63.76	71.11	84	1.9851	2.9756	0.6029	0.6088	1.6473E+06
BFE5-2A-080481-5	389.62	114.89	580.36	61.54	211.79	49	3.3912	2.9274	0.6016	0.6075	2.8253E+06
BFE5-2A-080481-6	389.98	161.33	588.03	63.47	108.29	69	2.4173	2.9541	0.5971	0.6029	2.0075E+06
BFE5-2A-080481-7	391.87	315.54	604.54	64.64	27.66	135	1.2419	3.0297	0.5994	0.6053	1.0284E+06
BFE5-2A-080581-1	416.66	251.68	598.54	65.00	49.56	108	1.6555	2.9973	0.6000	0.6059	1.3709E+06
BFE5-2A-080581-2	413.96	299.50	603.26	64.96	34.18	128	1.3822	3.0213	0.6010	0.6068	1.1442E+06
BFE5-2A-080581-3	413.59	125.41	583.87	63.10	198.20	54	3.2979	2.9354	0.6040	0.6099	2.7411E+06
BFE5-2A-080581-4	413.82	172.00	589.94	63.84	105.08	74	2.4059	2.9614	0.6026	0.6085	1.9968E+06
BFE5-2A-080581-5	414.56	248.13	601.48	64.52	50.01	106	1.6707	3.0151	0.6011	0.6070	1.3841E+06
BFE5-2A-080581-6	414.32	124.08	584.70	62.89	202.68	53	3.3391	2.9409	0.6042	0.6101	2.7760E+06
BFE5-2A-080581-7	415.65	314.41	606.84	64.90	30.90	135	1.3220	3.0396	0.6027	0.6086	1.0941E+06

Table 8(b) (cont.). Test Number, Measured and Calculated Quantities  
Nominal 4 Inch AGA/API Orifice Meter (British Units).

Test Identification	Test Draft (lb)	Test Time (s)	Press. Note 1 (psia)	Temp. Note 2 (°F)	Diff. Press. Note 3 (in H <sub>2</sub> O)	Data Samples N	Mass Flow Rate (lb/s)	Orifice Meter Density (lb/ft <sup>3</sup> )	CY <sub>2</sub>	KY <sub>2</sub>	Orifice Bore R <sub>d</sub>
BFES-2B-060481-1	343.35	256.71	605.17	60.20	31.35	107	1.3375	3.0616	0.6029	0.6088	1.1138E+06
BFES-2B-060481-2	371.93	107.93	585.30	59.32	211.55	45	3.4461	2.9663	0.6075	0.6134	2.8777E+06
BFES-2B-060481-3	329.29	240.77	605.54	60.13	32.56	101	1.3677	3.0639	0.6048	0.6107	1.1390E+06
BFES-2B-060481-4	352.43	203.31	602.77	59.59	52.69	85	1.7335	3.0534	0.6036	0.6095	1.4450E+06
BFES-2B-060481-5	351.49	169.11	601.49	59.29	75.31	71	2.0785	3.0488	0.6057	0.6117	1.7334E+06
BFES-2B-060481-6	352.09	141.77	594.24	59.41	107.39	59	2.4835	3.0112	0.6099	0.6159	2.0722E+06
BFES-2B-060481-7	351.80	209.35	603.90	59.91	49.74	88	1.6804	3.0570	0.6018	0.6077	1.4000E+06
BFES-2B-060481-8	351.31	174.99	602.04	59.43	71.18	73	2.0076	3.0507	0.6017	0.6076	1.6739E+06
BFES-2B-060481-9	339.07	289.41	605.87	59.91	23.96	121	1.1716	3.0671	0.6037	0.6096	9.7594E+05
BFES-2B-060481-10	369.52	144.85	593.13	58.66	112.38	61	2.5510	3.0104	0.6125	0.6185	2.1308E+06
BFES-2B-080581-1	395.20	241.24	597.14	63.73	47.49	103	1.6382	2.9983	0.6063	0.6122	1.3587E+06
BFES-2B-080581-2	394.54	165.14	590.14	62.67	100.42	71	2.3891	2.9697	0.6109	0.6169	1.9855E+06
BFES-2B-080581-3	395.04	194.44	594.91	63.19	73.50	83	2.0317	2.9905	0.6052	0.6111	1.6866E+06
BFES-2B-080581-4	395.62	164.18	587.88	62.88	103.79	70	2.4097	2.9570	0.6080	0.6139	2.0024E+06
BFES-2B-080581-5	395.69	245.98	600.14	64.02	45.79	105	1.6086	3.0116	0.6049	0.6109	1.3334E+06
BFES-2B-080581-6	396.36	291.40	603.11	63.54	32.36	125	1.3602	3.0296	0.6068	0.6127	1.1279E+06
BFES-2B-080581-7	395.24	198.03	596.28	63.41	69.98	85	1.9958	2.9960	0.6087	0.6146	1.6562E+06
BFES-2B-080581-8	395.16	117.72	582.77	62.12	201.60	51	3.3568	2.9359	0.6092	0.6152	2.7933E+06
BFES-2B-080581-9	338.95	279.36	605.41	64.06	25.76	119	1.2133	3.0379	0.6059	0.6118	1.0052E+06
BFES-2B-101581-1	371.76	149.49	586.07	62.32	110.91	64	2.4869	2.9513	0.6069	0.6129	2.0684E+06
BFES-2B-101581-2	371.14	192.13	597.91	62.70	65.84	82	1.9317	3.0087	0.6061	0.6120	1.6042E+06
BFES-2B-101581-3	352.18	269.15	605.47	62.69	29.83	115	1.3085	3.0469	0.6062	0.6121	1.0860E+06
BFES-2B-101581-4	352.20	145.92	592.71	62.40	102.99	63	2.4137	2.9844	0.6079	0.6139	2.0062E+06
BFES-2B-101581-5	338.06	248.85	604.56	62.71	32.25	107	1.3585	3.0422	0.6058	0.6117	1.1276E+06
BFES-2B-101581-6	338.97	216.16	598.05	62.59	43.81	92	1.5681	3.0102	0.6030	0.6089	1.3025E+06
BFES-2B-101581-7	337.40	102.03	581.97	62.15	197.86	44	3.3069	2.9317	0.6063	0.6122	2.7519E+06
BFES-2B-101581-8	340.16	179.83	591.35	62.45	64.79	77	1.8916	2.9773	0.6014	0.6073	1.5723E+06
BFES-2B-101581-9	339.18	275.62	601.28	62.40	26.50	118	1.2306	3.0276	0.6069	0.6128	1.0221E+06
BFES-2B-101581-10	369.62	143.00	590.29	65.77	119.09	60	2.5848	2.9511	0.6091	0.6150	2.1397E+06
BFES-2B-101581-11	370.64	231.73	598.91	66.12	45.37	97	1.5994	2.9921	0.6067	0.6126	1.3225E+06
BFES-2B-101581-12	369.89	111.67	582.13	65.23	201.47	47	3.3124	2.9136	0.6039	0.6098	2.7458E+06
BFES-2A-052181-1	370.07	193.91	595.83	66.26	65.90	81	1.9085	2.9758	0.6021	0.6079	1.5781E+06
BFES-2A-052181-2	340.56	265.64	595.88	66.15	29.73	111	1.2820	2.9768	0.6024	0.6083	1.0603E+06
BFES-2A-052181-3	340.89	140.62	589.95	66.32	108.58	59	2.4242	2.9460	0.5988	0.6046	2.0054E+06
BFES-2A-052181-4	341.39	255.46	597.31	66.75	32.68	107	1.3364	2.9802	0.5983	0.6042	1.1042E+06
BFES-2A-052181-5	339.80	138.03	593.10	66.39	109.94	58	2.4618	2.9614	0.6027	0.6085	2.0358E+06
BFES-2A-052181-6	340.20	210.88	606.31	67.03	46.98	88	1.6133	3.0234	0.5981	0.6039	1.3316E+06
BFES-2A-052181-7	318.36	278.64	608.09	66.37	23.34	116	1.1425	3.0365	0.5998	0.6056	9.4372E+05
BFES-2A-052181-8	315.78	277.10	609.10	66.26	23.01	116	1.1396	3.0422	0.6025	0.6084	9.4132E+05

Table 8(b) (cont.). Test Number, Measured and Calculated Quantities  
Nominal 4 Inch AGA/API Orifice Meter (British Units).

Test Identification	Test Draft (lb)	Test Draft Time (s)	Press. Note 1 (psia)	Temp. Note 2 (°F)	Diff. Press. Note 3 (in H <sub>2</sub> O)	Data Samples N	Mass Flow Rate (lb/s)	Orifice Meter Density (lb/ft <sup>3</sup> )	CY <sub>2</sub>	KY <sub>2</sub>	Orifice Bore Kd
BFE6-2B-052281-1	376.76	236.60	597.57	57.47	44.78	99	1.5924	3.0407	0.6028	0.6086	1.3317E+06
BFE6-2B-052281-2	376.35	109.78	585.06	57.44	207.78	46	3.4282	2.9770	0.6087	0.6147	2.8701E+06
BFE6-2B-052281-3	367.57	186.31	598.94	57.49	68.02	78	1.9729	3.0476	0.6052	0.6111	1.6497E+06
BFE6-2B-052281-4	368.33	273.32	603.64	58.14	31.41	114	1.3476	3.0673	0.6064	0.6123	1.1254E+06
BFE6-2B-052281-5	367.09	144.77	591.77	56.54	112.27	60	2.5357	3.0171	0.6084	0.6144	2.1242E+06
BFE6-2B-052281-6	368.36	277.68	603.18	57.99	30.63	116	1.3266	3.0660	0.6046	0.6105	1.1081E+06
BFE6-2B-052281-7	366.96	147.78	590.89	56.93	108.74	62	2.4832	3.0101	0.6062	0.6122	2.0793E+06
BFE6-2B-052281-8	367.84	229.31	602.86	57.36	44.67	96	1.6041	3.0684	0.6052	0.6111	1.3411E+06
BFE6-2B-052281-10	366.96	106.83	582.58	58.20	211.18	45	3.4350	2.9595	0.6068	0.6127	2.8734E+06
BFE6-2B-052281-11	368.95	316.31	597.91	57.68	23.43	132	1.1664	3.0411	0.6108	0.6168	9.7516E+05
BFE6-2B-052881-1	416.19	205.62	596.42	58.99	72.25	86	2.0241	3.0250	0.6046	0.6105	1.6894E+06
BFE6-2B-052881-2	409.38	121.64	581.78	58.34	203.10	51	3.3655	2.9546	0.6067	0.6126	2.8149E+06
BFE6-2B-052881-3	322.10	187.24	593.99	58.76	52.17	78	1.7202	3.0141	0.6058	0.6118	1.4366E+06
BFE6-2B-052881-4	337.67	176.04	594.06	58.59	65.04	74	1.9182	3.0156	0.6049	0.6108	1.6022E+06
BFE6-2B-052881-5	333.06	198.32	599.43	58.88	49.47	83	1.6794	3.0410	0.6048	0.6107	1.4016E+06
BFE6-2B-052881-6	351.75	103.20	580.53	57.96	208.77	43	3.4084	2.9506	0.6065	0.6124	2.8526E+06
BFE6-2B-052881-7	351.33	140.55	586.70	58.72	111.96	59	2.4997	2.9772	0.6046	0.6105	2.0888E+06
BFE6-2B-052881-8	353.04	247.52	597.56	59.25	35.98	103	1.4263	3.0291	0.6035	0.6094	1.1900E+06
BFE5-3A-060281-1	351.70	117.69	593.22	59.33	47.91	49	2.9884	3.0065	0.6055	0.6248	1.8708E+06
BFE5-3A-060281-2	357.49	190.11	598.62	59.46	18.93	79	1.8804	3.0331	0.6035	0.6228	1.1765E+06
BFE5-3A-060281-3	360.46	93.80	584.06	58.80	80.45	39	3.8429	2.9633	0.6052	0.6245	2.4093E+06
BFE5-3A-060281-4	362.61	187.14	593.08	59.69	20.31	78	1.9376	3.0035	0.6035	0.6228	1.2125E+06
BFE5-3A-060281-5	361.95	123.40	591.41	58.91	46.33	52	2.9332	3.0000	0.6050	0.6244	1.8376E+06
BFE5-3A-060281-6	361.45	91.95	583.98	58.73	84.91	39	3.9310	2.9633	0.6026	0.6219	2.4648E+06
BFE5-3A-060281-7	362.19	67.33	560.86	59.15	165.21	28	5.3793	2.8431	0.6035	0.6228	3.3775E+06
BFE5-3A-060281-8	329.31	146.25	598.90	58.93	26.70	61	2.2517	3.0380	0.6080	0.6274	1.4097E+06
BFE5-3A-060281-9	333.25	254.91	608.83	59.82	9.08	107	1.3073	3.0826	0.6010	0.6202	8.1684E+05
BFE5-3B-111281-1	395.03	139.13	588.62	65.17	43.84	60	2.8393	2.9465	0.6073	0.6267	1.7643E+06
BFE5-3B-111281-2	395.90	246.35	595.52	65.51	13.73	105	1.6074	2.9790	0.6110	0.6305	9.9784E+05
BFE5-3B-111281-3	395.23	101.42	575.81	63.95	83.28	43	3.8969	2.8896	0.6107	0.6302	2.4279E+06
BFE5-3B-111281-4	395.65	188.48	584.73	65.17	24.01	81	2.0992	2.9270	0.6088	0.6282	1.3048E+06
BFE5-3B-111281-5	395.17	138.59	582.24	64.18	43.87	59	2.8514	2.9205	0.6124	0.6320	1.7751E+06
BFE5-3B-111281-6	395.34	102.92	576.54	64.67	81.72	44	3.8412	2.8889	0.6077	0.6271	2.3908E+06
BFE5-3B-111281-7	396.27	74.74	549.88	62.83	162.96	32	5.3020	2.7656	0.6071	0.6265	3.3152E+06
BFE5-3B-111281-8	395.51	182.79	586.37	64.97	25.48	78	2.1637	2.9364	0.6080	0.6275	1.3451E+06
BFE5-3B-111281-9	356.63	271.41	594.24	65.87	9.28	116	1.3140	2.9703	0.6084	0.6279	8.1539E+05

Table 8(b) (cont.). Test Number, Measured and Calculated Quantities  
Nominal 4 Inch AGA/API Orifice Meter (British Units).

Test Identification	Test Draft (lb)	Test Time (s)	Press. Note 1 (psia)	Temp. Note 2 (°F)	Diff. Press. Note 3 (in H <sub>2</sub> O)	Data Samples N	Mass Flow Rate (lb/s)	Orifice Meter Density (lb/ft <sup>3</sup> )	CY <sub>2</sub>	KY <sub>2</sub>	Orifice Bore	
											Rd	Rd
BFE6-3A-051481-1	381.63	84.78	568.43	65.76	115.03	30	4.5014	2.8417	0.6054	0.6247	2.7998E+06	
BFE6-3A-051481-2	399.83	181.86	587.70	65.73	26.30	63	2.1985	2.9384	0.6081	0.6275	1.3654E+06	
BFE6-3A-051481-3	396.50	210.82	592.70	65.64	18.93	73	1.8807	2.9641	0.6109	0.6303	1.1677E+06	
BFE6-3A-051481-4	398.29	136.99	586.17	65.74	46.46	48	2.9075	2.9307	0.6059	0.6252	1.8059E+06	
BFE6-3A-051481-5	398.57	102.99	577.54	65.52	83.72	36	3.8700	2.8887	0.6051	0.6244	2.4061E+06	
BFE6-3A-051481-6	399.04	136.59	586.94	65.80	47.03	48	2.9215	2.9342	0.6047	0.6240	1.8143E+06	
BFE6-3A-051481-7	399.30	87.21	572.43	61.83	116.69	30	4.5786	2.8855	0.6068	0.6261	2.8618E+06	
BFE6-3A-051481-8	400.11	217.22	593.40	65.97	18.44	75	1.8420	2.9655	0.6056	0.6249	1.1431E+06	
BFE6-3A-051481-9	333.32	258.54	582.32	66.84	8.90	90	1.2892	2.9048	0.6171	0.6368	7.9986E+05	
BFE6-3A-051481-10	334.47	236.46	582.60	66.66	11.00	82	1.4145	2.9073	0.6082	0.6276	8.7775E+05	
BFE6-3A-051581-2	400.29	184.59	580.82	66.46	26.18	77	2.1685	2.8995	0.6052	0.6245	1.3462E+06	
BFE6-3A-051581-3	401.30	222.04	581.41	66.23	17.93	93	1.8073	2.9038	0.6091	0.6285	1.1222E+06	
BFE6-3A-051581-4	400.47	138.88	576.90	66.07	46.52	58	2.8836	2.8822	0.6055	0.6248	1.7916E+06	
BFE6-3A-051581-5	400.52	103.90	578.53	66.00	81.66	44	3.8548	2.8909	0.6101	0.6295	2.3949E+06	
BFE6-3A-051581-6	402.05	137.11	586.25	66.24	47.16	57	2.9323	2.9280	0.6068	0.6261	1.8201E+06	
BFE6-3A-051581-7	402.73	89.44	573.34	62.64	112.90	38	4.5028	2.8952	0.6067	0.6260	2.8111E+06	
BFE6-3A-051581-8	403.09	213.78	595.76	66.47	19.13	89	1.8855	2.9742	0.6081	0.6274	1.1691E+06	
BFE6-3A-051581-9	404.71	290.80	587.49	66.54	10.60	122	1.3917	2.9324	0.6074	0.6264	8.6340E+05	
BFE6-3A-051581-10	403.42	105.20	577.89	66.56	82.78	44	3.8348	2.8843	0.6030	0.6227	2.3808E+06	
BFE6-3A-052781-1	382.91	207.10	590.98	59.00	18.40	87	1.8489	2.9972	0.6055	0.6248	1.1582E+06	
BFE6-3A-052781-2	383.76	72.19	564.88	57.34	156.69	30	5.3159	2.8746	0.6091	0.6286	3.3447E+06	
BFE6-3A-052781-3	383.50	130.43	586.91	57.75	46.12	55	2.9402	2.9845	0.6095	0.6290	1.8455E+06	
BFE6-3A-052781-4	383.35	97.51	576.98	56.44	83.96	41	3.9314	2.9420	0.6084	0.6277	2.4740E+06	
BFE6-3A-052781-5	383.62	174.72	585.71	58.37	26.00	73	2.1956	2.9744	0.6072	0.6266	1.3772E+06	
BFE6-3A-052781-6	383.28	134.74	583.16	58.29	43.94	57	2.8446	2.9619	0.6064	0.6257	1.7848E+06	
BFE6-3A-052781-7	383.41	211.96	589.14	58.66	17.47	89	1.8089	2.9900	0.6087	0.6281	1.1338E+06	
BFE6-3A-052781-8	383.37	98.95	577.03	57.59	82.19	41	3.8744	2.9351	0.6067	0.6260	2.4344E+06	
BFE6-3A-022582-1	410.14	141.74	588.59	61.68	45.25	61	2.8936	2.9681	0.6072	0.6265	1.8066E+06	
BFE6-3A-022582-2	410.76	75.81	549.23	61.30	171.36	33	5.4183	2.7713	0.6046	0.6239	3.3954E+06	
BFE6-3A-022582-3	410.66	242.72	595.95	62.67	15.17	104	1.6919	2.9991	0.6101	0.6295	1.0543E+06	
BFE6-3A-022582-4	410.19	77.11	533.43	59.49	170.06	33	5.3195	2.7016	0.6035	0.6228	3.3459E+06	
BFE6-3A-022582-5	409.86	107.24	571.36	61.97	82.37	46	3.8219	2.8792	0.6035	0.6227	2.3886E+06	
BFE6-3A-022582-6	471.22	221.33	603.84	62.44	24.10	95	2.1290	3.0403	0.6048	0.6240	1.3262E+06	
BFE6-3A-022582-7	472.17	282.74	600.94	62.69	15.10	121	1.6700	3.0241	0.6010	0.6201	1.0402E+06	
BFE6-3A-022582-8	470.47	118.49	580.35	62.12	87.62	51	3.9705	2.9237	0.6033	0.6225	2.4791E+06	
BFE6-3A-022582-9	471.87	356.59	602.63	63.14	9.31	152	1.3233	3.0297	0.6061	0.6254	8.2362E+05	

Table 8(b) (cont.). Test Number, Measured and Calculated Quantities  
Nominal 4 Inch AGA/API Orifice Meter (British Units).

Test Identification	Test Draft (lb)	Test Draft Time (s)	Press. Note 1 (psia)	Temp. Note 2 (°F)	Diff. Press. Note 3 (in H <sub>2</sub> O)	Data Samples N	Mass Flow Rate (lb/s)	Orifice Meter Density (lb/ft <sup>3</sup> )	CY <sub>2</sub>	KY <sub>2</sub>	Orifice Bore R <sub>d</sub>
BFE6-3B-022482-1	418.68	256.50	591.91	62.83	14.39	110	1.6323	2.9776	0.6063	0.6256	1.0171E+06
BFE6-3B-022482-2	417.81	109.06	573.74	62.03	81.78	47	3.8310	2.8909	0.6058	0.6251	2.3933E+06
BFE6-3B-022482-3	417.79	146.47	583.93	62.02	44.77	63	2.8524	2.9424	0.6042	0.6235	1.7805E+06
BFE6-3B-022482-4	418.16	196.88	588.21	61.36	24.56	84	2.1239	2.9682	0.6048	0.6241	1.3265E+06
BFE6-3B-022482-5	420.48	147.26	581.86	61.88	44.81	63	2.8554	2.9329	0.6055	0.6248	1.7830E+06
BFE6-3B-022482-6	420.30	198.22	587.24	62.07	24.44	85	2.1204	2.9588	0.6062	0.6255	1.3231E+06
BFE6-3B-022482-7	420.39	109.18	572.83	61.29	82.84	47	3.8504	2.8908	0.6050	0.6242	2.4080E+06
BFE6-3B-022482-8	388.09	74.11	538.42	60.10	162.88	32	5.2366	2.7234	0.6045	0.6238	3.2893E+06
BFE6-3B-022482-9	387.97	282.53	590.66	62.66	9.90	121	1.3732	2.9724	0.6156	0.6352	8.5598E+05
BFE5-4A-080681-1	392.21	95.93	581.18	60.91	55.36	41	4.0885	2.9354	0.6039	0.6357	2.2724E+06
BFE5-4A-080681-2	390.58	187.15	596.83	63.82	14.10	80	2.0870	2.9962	0.6046	0.6365	1.1540E+06
BFE5-4A-080681-3	366.58	205.47	597.77	64.18	10.32	88	1.7841	2.9986	0.6039	0.6358	9.8599E+05
BFE5-4A-080681-4	395.19	130.95	588.44	63.43	29.86	56	3.0178	2.9564	0.6048	0.6367	1.6708E+06
BFE5-4A-080681-5	396.13	74.35	557.30	62.75	98.42	32	5.3279	2.8035	0.6039	0.6358	2.9598E+06
BFE5-4A-080681-6	396.92	198.86	597.16	63.96	13.08	85	1.9960	2.9970	0.6001	0.6318	1.1035E+06
BFE5-4A-080681-7	396.54	97.80	581.71	62.81	54.49	42	4.0546	2.9263	0.6045	0.6365	2.2478E+06
BFE5-4A-080681-8	396.98	165.36	591.67	63.43	18.72	71	2.4007	2.9727	0.6059	0.6379	1.3287E+06
BFE5-4A-080681-9	395.94	224.49	600.26	64.27	10.06	96	1.7637	3.0106	0.6033	0.6352	9.7443E+05
BFE5-4A-101681-1	379.77	70.28	561.48	60.50	98.95	30	5.4037	2.8381	0.6072	0.6392	3.0099E+06
BFE5-4A-101681-2	378.95	185.27	595.23	62.58	13.32	79	2.0454	2.9960	0.6097	0.6418	1.1330E+06
BFE5-4A-101681-3	378.37	215.66	591.17	62.79	9.90	92	1.7545	2.9742	0.6088	0.6409	9.7193E+05
BFE5-4A-101681-4	379.04	70.65	555.19	62.98	99.73	30	5.3650	2.7915	0.6054	0.6374	2.9800E+06
BFE5-4A-101681-5	380.47	154.29	585.78	63.03	20.15	66	2.4660	2.9454	0.6027	0.6345	1.3662E+06
BFE5-4A-101681-6	379.82	95.02	575.49	60.27	53.22	41	3.9972	2.9106	0.6047	0.6367	2.2246E+06
BFE5-4A-101681-7	393.11	128.43	582.39	62.39	30.60	55	3.0609	2.9323	0.6083	0.6405	1.6978E+06
BFE5-4A-101681-8	393.79	220.73	588.41	63.03	10.35	94	1.7840	2.9587	0.6071	0.6391	9.8820E+05
BFE5-4A-101681-9	393.48	96.09	575.69	62.65	55.36	41	4.0949	2.8969	0.6088	0.6409	2.2717E+06
BFE5-4A-101681-10	393.85	160.35	585.02	62.62	19.82	69	2.4562	2.9442	0.6053	0.6373	1.3616E+06
BFE5-4B-102281-1	379.18	94.84	573.74	63.83	53.18	41	3.9981	2.8799	0.6080	0.6402	2.2145E+06
BFE5-4B-102281-2	379.61	190.56	592.67	63.66	12.71	82	1.9921	2.9762	0.6095	0.6417	1.1019E+06
BFE5-4B-102281-3	377.97	216.21	596.97	63.91	9.76	92	1.7482	2.9964	0.6083	0.6404	9.6638E+05
BFE5-4B-102281-4	379.17	121.93	586.38	62.65	31.08	52	3.1098	2.9509	0.6111	0.6434	1.7234E+06
BFE5-4B-102281-5	359.25	67.19	552.07	64.05	99.48	29	5.3468	2.7696	0.6062	0.6383	2.9659E+06
BFE5-4B-102281-6	360.53	183.60	594.97	64.00	12.56	79	1.9637	2.9857	0.6035	0.6354	1.0856E+06
BFE5-4B-102281-7	359.52	88.74	576.79	62.29	54.14	38	4.0514	2.9047	0.6081	0.6402	2.2481E+06
BFE5-4B-102281-8	360.21	149.22	586.94	63.59	19.01	64	2.4140	2.9478	0.6069	0.6390	1.3361E+06
BFE5-4B-102281-9	361.50	198.34	593.85	63.77	10.83	85	1.8226	2.9815	0.6035	0.6354	1.0080E+06

Table 8(b) (cont.). Test Number, Measured and Calculated Quantities  
Nominal 4 Inch AGA/API Orifice Meter (British Units).

Test Identification	Test Draft (lb)	Test Draft Time (s)	Press. Note 1 (psia)	Temp. Note 2 (°F)	Diff. Press. Note 3 (in H <sub>2</sub> O)	Data Samples N	Mass Flow Rate (lb/s)	Orifice Meter Density (lb/ft <sup>3</sup> )	CY <sub>2</sub>	KY <sub>2</sub>	Orifice Bore Rd
BF6E-4A-102882-1	428.75	104.12	582.21	57.51	55.27	49	4.1178	2.9620	0.6061	0.6380	2.2989E+06
BF6E-4A-102882-2	428.91	214.05	598.09	59.05	12.74	99	2.0038	3.0331	0.6070	0.6389	1.1149E+06
BF6E-4A-102882-3	456.43	255.29	597.77	59.04	10.12	118	1.7879	3.0315	0.6079	0.6399	9.9483E+05
BF6E-4A-102882-4	479.36	154.52	586.22	58.24	31.65	72	3.1023	2.9778	0.6018	0.6335	1.7297E+06
BF6E-4A-102882-5	480.16	89.53	550.46	58.57	100.16	42	5.3631	2.7936	0.6038	0.6356	2.9977E+06
BF6E-4A-102882-6	480.41	229.86	599.10	58.54	13.98	106	2.0900	3.0415	0.6037	0.6354	1.1636E+06
BF6E-4A-102882-7	477.86	117.35	579.72	57.36	53.70	55	4.0721	2.9503	0.6093	0.6413	2.2743E+06
BF6E-4A-102882-8	478.09	192.24	591.11	58.69	19.88	89	2.4869	2.9999	0.6066	0.6385	1.3852E+06
BF6E-4A-102882-9	480.66	269.51	595.44	59.49	10.07	125	1.7835	3.0168	0.6092	0.6413	9.9197E+05
BF6E-4B-022582-1	471.42	115.49	582.43	62.50	54.90	50	4.0819	2.9319	0.6056	0.6375	2.2633E+06
BF6E-4B-022582-2	471.41	225.92	597.97	63.03	13.88	97	2.0866	3.0070	0.6079	0.6399	1.1547E+06
BF6E-4B-022582-3	471.95	261.35	598.89	63.32	10.42	112	1.8058	3.0097	0.6071	0.6391	9.9885E+05
BF6E-4B-022582-4	470.71	150.52	587.51	62.58	31.45	65	3.1272	2.9570	0.6104	0.6425	1.7331E+06
BF6E-4B-022582-5	471.38	90.13	545.63	59.81	95.83	39	5.2300	2.7617	0.6052	0.6370	2.9190E+06
BF6E-4B-022582-6	470.20	227.90	589.33	63.49	13.89	97	2.0632	2.9605	0.6056	0.6375	1.1418E+06
BF6E-4B-022582-7	471.05	118.63	568.87	62.73	53.69	51	3.9707	2.8620	0.6030	0.6347	2.2034E+06
BF6E-4B-022582-8	486.31	199.88	584.71	62.89	19.16	85	2.4330	2.9410	0.6101	0.6422	1.3481E+06
BF6E-4B-022582-9	486.32	284.12	586.29	63.00	9.43	121	1.7117	2.9483	0.6110	0.6432	9.4817E+05
BF6E-4B-100182-1	423.28	102.55	578.52	57.67	55.44	48	4.1276	2.9422	0.6084	0.6404	2.3041E+06
BF6E-4B-100182-2	424.72	208.34	596.25	58.16	13.06	96	2.0386	3.0295	0.6102	0.6424	1.1356E+06
BF6E-4B-100182-3	425.44	247.22	601.41	58.27	9.31	114	1.7209	3.0551	0.6074	0.6394	9.5806E+05
BF6E-4B-100182-4	424.20	135.54	584.39	57.82	31.61	63	3.1297	2.9712	0.6080	0.6400	1.7459E+06
BF6E-4B-100182-5	424.75	78.84	546.39	57.62	100.83	37	5.3875	2.7784	0.6060	0.6378	3.0157E+06
BF6E-4B-100182-6	425.21	207.51	595.91	58.16	13.27	96	2.0491	3.0277	0.6086	0.6407	1.1415E+06
BF6E-4B-100182-7	424.65	104.87	574.27	58.16	53.90	49	4.0493	2.9174	0.6079	0.6399	2.2598E+06
BF6E-4B-100182-8	425.60	169.49	584.61	57.97	20.29	79	2.5111	2.9714	0.6089	0.6409	1.4005E+06
BF6E-4B-100182-9	426.17	250.43	594.71	58.38	9.17	115	1.7017	3.0203	0.6088	0.6408	9.4780E+05
BF6E-5A-060381-1	369.23	116.51	594.31	58.83	15.47	49	3.1691	3.0153	0.6111	0.6754	1.5120E+06
BF6E-5A-060381-2	369.35	125.59	594.61	58.58	13.35	53	2.9409	3.0184	0.6103	0.6745	1.4036E+06
BF6E-5A-060381-3	370.08	68.05	563.14	60.39	48.43	29	5.4384	2.8472	0.6101	0.6743	2.5961E+06
BF6E-5A-060381-4	370.19	80.86	580.88	58.15	33.34	34	4.5782	2.9512	0.6080	0.6719	2.1888E+06
BF6E-5A-060381-5	369.74	98.96	588.85	57.92	21.84	42	3.7362	2.9933	0.6087	0.6727	1.7856E+06
BF6E-5A-060381-6	370.91	68.43	561.92	56.82	48.05	29	5.4203	2.8626	0.6089	0.6729	2.6001E+06
BF6E-5A-060381-7	370.35	145.85	595.11	59.18	9.96	61	2.5392	3.0171	0.6101	0.6743	1.2109E+06
BF6E-5A-060381-8	370.22	129.50	592.29	58.97	12.74	54	2.8589	3.0041	0.6086	0.6726	1.3640E+06
BF6E-5A-060381-9	369.89	101.93	586.23	57.77	20.63	43	3.6288	2.9809	0.6095	0.6736	1.7350E+06

Table 8(b) (cont.). Test Number, Measured and Calculated Quantities  
Nominal 4 Inch AGA/API Orifice Meter (British Units).

Test Identification	Test Draft (lb)	Test Draft Time (s)	Press. Note 1 (psia)	Temp. Note 2 (°F)	Diff. Press. Note 3 (in H <sub>2</sub> O)	Data Samples N	Mass Flow Rate (lb/s)	Orifice Meter Density (lb/ft <sup>3</sup> )	CY <sub>1</sub>	KY <sub>1</sub>	Orifice Bore Rd
BFE5-5A-060481-1	341.42	63.49	564.50	59.74	47.06	27	5.3776	2.8580	0.6108	0.6750	2.5690E+06
BFE5-5A-060481-2	414.59	112.63	590.01	59.07	21.36	47	3.6810	2.9919	0.6065	0.6703	1.7564E+06
BFE5-5A-060481-3	395.91	136.80	591.55	59.69	13.21	57	2.8941	2.9957	0.6060	0.6697	1.3796E+06
BFE5-5A-060481-4	409.09	130.12	591.10	59.05	15.58	55	3.1439	2.9975	0.6060	0.6698	1.5000E+06
BFE5-5A-060481-5	409.76	89.25	579.17	60.75	33.96	37	4.5912	2.9262	0.6067	0.6704	2.1877E+06
BFE5-5A-060481-6	410.49	133.56	590.62	59.57	15.01	56	3.0735	2.9918	0.6041	0.6676	1.4654E+06
BFE5-5A-060481-7	408.93	162.06	593.04	59.09	9.97	68	2.5233	3.0072	0.6070	0.6708	1.2036E+06
BFE5-5A-060481-8	410.46	88.39	578.93	60.40	34.44	37	4.6437	2.9272	0.6093	0.6733	2.2138E+06
BFE5-5A-060481-9	410.62	140.71	591.69	59.24	13.41	59	2.9182	2.9993	0.6061	0.6698	1.3919E+06
BFE5-5A-060481-10	410.68	78.02	561.84	59.74	46.10	33	5.2638	2.8445	0.6055	0.6692	2.5152E+06
BFE5-5B-102081-1	408.32	77.08	561.36	64.85	46.16	33	5.2973	2.8116	0.6123	0.6767	2.5137E+06
BFE5-5B-102081-2	408.59	113.51	581.89	62.46	20.20	49	3.5996	2.9294	0.6161	0.6809	1.7107E+06
BFE5-5B-102081-3	408.67	143.07	590.06	63.89	12.53	61	2.8564	2.9617	0.6174	0.6824	1.3540E+06
BFE5-5B-102081-4	408.50	133.26	588.64	63.73	14.50	57	3.0654	2.9556	0.6165	0.6814	1.4536E+06
BFE5-5B-102081-5	409.00	92.03	576.69	64.33	31.74	40	4.4442	2.8917	0.6108	0.6750	2.1078E+06
BFE5-5B-102081-6	409.02	164.42	588.31	63.65	9.77	70	2.4876	2.9544	0.6097	0.6739	1.1798E+06
BFE5-5B-102081-7	408.72	131.98	585.51	63.68	15.13	57	3.0968	2.9401	0.6114	0.6757	1.4689E+06
BFE5-5B-102081-8	408.78	90.97	577.02	63.46	32.33	39	4.4936	2.8987	0.6112	0.6755	2.1336E+06
BFE5-5B-102081-9	409.00	147.21	583.83	63.95	12.31	63	2.7784	2.9299	0.6090	0.6731	1.3176E+06
BFE6-5A-052781-1	384.64	102.24	592.26	57.65	22.14	43	3.7621	3.0124	0.6072	0.6707	1.7981E+06
BFE6-5A-052781-2	384.68	142.57	595.56	58.23	11.32	59	2.6982	3.0255	0.6075	0.6711	1.2883E+06
BFE6-5A-052781-3	383.07	73.10	569.27	56.93	44.55	31	5.2404	2.8995	0.6077	0.6713	2.5119E+06
BFE6-5A-052781-4	388.24	133.67	590.97	58.32	13.24	56	2.9045	3.0015	0.6072	0.6707	1.3871E+06
BFE6-5A-052781-5	384.97	119.30	589.87	58.39	16.36	50	3.2269	2.9955	0.6074	0.6710	1.5411E+06
BFE6-5A-052781-6	384.75	84.14	578.18	57.70	33.53	35	4.5728	2.9402	0.6070	0.6705	2.1880E+06
BFE6-5A-052781-7	385.17	120.54	589.61	58.57	16.06	50	3.1953	2.9930	0.6074	0.6710	1.5257E+06
BFE6-5A-052781-8	384.93	144.49	591.93	58.52	11.10	60	2.6640	3.0051	0.6079	0.6715	1.2718E+06
BFE6-5A-052781-9	384.87	105.37	586.57	57.32	21.03	44	3.6525	2.9855	0.6075	0.6711	1.7473E+06
BFE6-5A-052781-10	384.64	71.69	562.68	55.39	47.25	30	5.3654	2.8753	0.6067	0.6702	2.5786E+06
BFE6-5A-052981-1	429.69	158.58	587.15	58.35	11.44	67	2.7096	2.9819	0.6114	0.6754	1.2944E+06
BFE6-5A-052981-2	428.29	134.55	583.32	58.21	15.85	56	3.1832	2.9633	0.6121	0.6762	1.5214E+06
BFE6-5A-052981-3	413.67	77.15	560.31	59.31	47.59	32	5.3619	2.8393	0.6079	0.6715	2.5639E+06
BFE6-5A-052981-4	413.54	154.57	587.50	58.63	11.30	65	2.6754	2.9819	0.6073	0.6709	1.2776E+06
BFE6-5A-052981-5	413.48	90.82	576.23	58.89	33.32	38	4.5527	2.9229	0.6080	0.6716	2.1753E+06
BFE6-5A-052981-6	414.55	78.29	562.73	58.41	46.28	33	5.2950	2.8570	0.6069	0.6704	2.5344E+06
BFE6-5A-052981-7	372.71	123.56	587.40	58.69	14.49	52	3.0164	2.9810	0.6048	0.6681	1.4403E+06
BFE6-5A-052981-8	370.61	99.72	583.77	58.55	21.97	42	3.7165	2.9634	0.6070	0.6706	1.7755E+06
BFE6-5A-052981-9	370.84	117.91	586.85	58.70	15.69	50	3.1451	2.9781	0.6063	0.6698	1.5018E+06
BFE6-5A-052981-10	370.25	141.45	589.61	57.93	10.82	59	2.6175	2.9971	0.6057	0.6692	1.2509E+06
BFE6-5A-052981-11	370.75	114.00	591.04	58.02	16.54	48	3.2522	3.0038	0.6081	0.6718	1.5538E+06

Table 8(b) (cont.). Test Number, Measured and Calculated Quantities  
Nominal 4 Inch AGA/API Orifice Meter (British Units).

Test Identification	Test Draft (lb)	Test Draft Time (s)	Press. Note 1 (psia)	Temp. Note 2 (°F)	Diff. Press. Note 3 (in H <sub>2</sub> O)	Data Samples N	Mass Flow Rate (lb/s)	Orifice Meter Density (lb/ft <sup>3</sup> )	CY <sub>2</sub>	KY <sub>2</sub>	Orifice Bore Rd
BF6-5B-022482-1	457.37	150.48	586.45	62.64	14.65	65	3.0394	2.9513	0.6089	0.6727	1.4436E+06
BF6-5B-022482-2	457.42	167.61	585.20	62.83	11.95	72	2.7291	2.9438	0.6061	0.6696	1.2960E+06
BF6-5B-022482-3	457.52	86.13	547.31	63.15	48.51	37	5.3120	2.7508	0.6057	0.6692	2.5292E+06
BF6-5B-022482-4	456.71	104.47	568.10	64.02	31.69	45	4.3717	2.8504	0.6059	0.6693	2.0757E+06
BF6-5B-022482-5	464.30	129.44	578.11	63.08	20.80	56	3.5870	2.9065	0.6077	0.6714	1.7038E+06
BF6-5B-022482-6	464.68	87.55	544.26	63.54	48.59	38	5.3076	2.7332	0.6067	0.6702	2.5265E+06
BF6-5B-022482-7	464.74	186.14	581.42	63.05	9.98	80	2.4967	2.9234	0.6087	0.6725	1.1857E+06
BF6-5B-022482-8	464.48	168.57	580.26	62.78	12.24	72	2.7554	2.9192	0.6071	0.6707	1.3091E+06
BF6-5B-022482-9	464.12	129.67	573.90	62.69	20.70	55	3.5792	2.8876	0.6098	0.6737	1.7016E+06
BF6-5B-092982-1	384.20	121.78	584.34	58.83	15.72	57	3.1549	2.9645	0.6087	0.6725	1.5063E+06
BF6-5B-092982-2	383.90	139.50	586.66	58.72	11.78	65	2.7519	2.9771	0.6121	0.6762	1.3139E+06
BF6-5B-092982-3	383.89	70.44	558.65	55.90	48.33	33	5.4499	2.8515	0.6116	0.6757	2.6179E+06
BF6-5B-092982-4	383.11	86.10	570.89	57.58	31.53	40	4.4495	2.9038	0.6126	0.6768	2.1303E+06
BF6-5B-092982-5	384.57	106.03	578.00	58.33	20.92	50	3.6270	2.9354	0.6098	0.6736	1.7338E+06
BF6-5B-092982-6	383.88	70.74	554.70	60.55	48.98	33	5.4266	2.8034	0.6101	0.6740	2.5913E+06
BF6-5B-092982-7	386.28	155.58	582.67	58.58	9.57	72	2.4828	2.9576	0.6148	0.6792	1.1860E+06
BF5-6A-080681-1	404.37	110.23	586.28	63.41	10.66	47	3.6684	2.9456	0.6060	0.7293	1.5228E+06
BF5-6A-080681-2	404.56	84.88	573.23	63.25	18.33	37	4.7663	2.8809	0.6072	0.7307	1.9811E+06
BF5-6A-080681-3	404.67	109.16	583.19	62.92	10.91	47	3.7071	2.9331	0.6065	0.7299	1.5403E+06
BF5-6A-080681-4	404.14	95.03	578.17	63.00	14.58	41	4.2528	2.9073	0.6046	0.7275	1.7676E+06
BF5-6A-080681-5	405.29	74.06	555.47	64.51	25.22	32	5.4724	2.7840	0.6045	0.7275	2.2740E+06
BF5-6A-080681-6	404.19	102.32	581.77	63.32	12.62	44	3.9503	2.9234	0.6019	0.7243	1.6406E+06
BF5-6A-080681-7	404.74	113.18	583.33	63.19	10.16	48	3.5760	2.9322	0.6063	0.7296	1.4853E+06
BF5-6A-080681-8	404.69	109.63	582.48	62.79	10.92	47	3.6914	2.9303	0.6040	0.7268	1.5341E+06
BF5-6A-080681-9	404.60	85.16	571.80	62.45	18.33	37	4.7510	2.8785	0.6054	0.7286	1.9771E+06
BF5-6B-102081-1	409.65	111.06	588.12	64.09	10.67	48	3.6886	2.9507	0.6089	0.7326	1.5300E+06
BF5-6B-102081-2	409.43	86.81	570.25	63.68	17.85	37	4.7164	2.8632	0.6111	0.7352	1.9602E+06
BF5-6B-102081-3	408.68	111.21	576.76	65.05	10.90	48	3.6749	2.8877	0.6068	0.7300	1.5238E+06
BF5-6B-102081-4	409.19	97.32	570.16	65.60	14.38	42	4.2046	2.8513	0.6083	0.7318	1.7431E+06
BF5-6B-102081-5	409.43	75.00	549.54	64.16	24.81	33	5.4591	2.7562	0.6115	0.7357	2.2713E+06
BF5-6B-102081-6	409.23	105.65	569.44	65.43	12.38	46	3.8735	2.8487	0.6041	0.7268	1.6063E+06
BF5-6B-102081-7	409.22	116.45	577.13	64.58	9.95	50	3.5141	2.8924	0.6068	0.7300	1.4580E+06
BF5-6B-102081-8	409.51	96.66	572.38	64.79	14.62	41	4.2366	2.8673	0.6061	0.7292	1.7579E+06



Table 8(b) (cont.). Test Number, Measured and Calculated Quantities  
Nominal 4 Inch AGA/API Orifice Meter (British Units).

Test Identification	Test Draft (lb)	Test Time (s)	Press. Note 1 (psia)	Temp. Note 2 (°F)	Diff. Press. Note 3 (in H <sub>2</sub> O)	Data Samples N	Mass Flow Rate (lb/s)	Orifice Meter Density (lb/ft <sup>3</sup> )	CY <sub>2</sub>	KY <sub>2</sub>	Orifice Bore R <sub>d</sub>
BF66-6A-102982-1	446.87	119.19	581.12	57.85	11.14	56	3.7492	2.9543	0.6054	0.7279	1.5686E+06
BF66-6A-102982-2	493.71	103.67	573.00	57.66	18.14	49	4.7624	2.9140	0.6069	0.7297	1.9943E+06
BF66-6A-102982-3	493.18	130.10	591.31	58.18	11.09	61	3.7908	3.0042	0.6083	0.7315	1.5839E+06
BF66-6A-102982-4	493.34	116.00	579.84	57.81	14.30	54	4.2529	2.9480	0.6069	0.7297	1.7796E+06
BF66-6A-102982-5	494.27	92.26	553.28	57.13	23.96	43	5.3574	2.8166	0.6043	0.7266	2.2488E+06
BF66-6A-102982-6	493.74	124.01	579.30	57.99	12.66	58	3.9814	2.9441	0.6040	0.7263	1.6657E+06
BF66-6A-102982-7	492.93	136.96	583.67	58.43	10.21	64	3.5990	2.9636	0.6061	0.7288	1.5043E+06
BF66-6A-102982-8	491.12	115.81	572.15	56.91	14.36	54	4.2407	2.9144	0.6072	0.7302	1.7778E+06
BF66-6A-102982-9	491.43	106.12	561.35	57.54	17.64	50	4.6309	2.8553	0.6045	0.7268	1.9415E+06
BF66-6B-093082-1	390.51	107.05	586.52	58.49	10.56	50	3.6479	2.9778	0.6033	0.7252	1.5246E+06
BF66-6B-093082-2	389.95	81.56	569.21	57.39	18.50	38	4.7812	2.8963	0.6056	0.7280	2.0041E+06
BF66-6B-093082-3	423.50	113.42	586.31	58.54	10.88	53	3.7339	2.9764	0.6084	0.7314	1.5605E+06
BF66-6B-093082-4	423.20	99.54	578.27	58.15	14.42	46	4.2515	2.9378	0.6057	0.7281	1.7789E+06
BF66-6B-093082-5	424.86	78.88	553.66	57.28	24.21	37	5.3862	2.8176	0.6047	0.7269	2.2609E+06
BF66-6B-093082-6	424.74	109.30	581.89	58.14	11.98	51	3.8860	2.9564	0.6053	0.7277	1.6255E+06
BF66-6B-093082-7	423.94	118.44	587.49	58.10	9.92	55	3.5794	2.9852	0.6099	0.7332	1.4966E+06
BF66-6B-093082-8	423.09	98.36	578.62	57.60	14.75	46	4.3015	2.9431	0.6053	0.7277	1.8011E+06
BF66-6B-093082-9	423.70	89.42	570.03	59.87	18.21	42	4.7383	2.8853	0.6060	0.7285	1.9794E+06
BF66-6B-100782-1	377.47	101.69	588.68	59.39	10.83	47	3.7119	2.9830	0.6054	0.7278	1.5492E+06
BF66-6B-100782-2	410.24	86.50	573.74	58.61	18.09	40	4.7427	2.9119	0.6059	0.7284	1.9840E+06
BF66-6B-100782-3	410.06	107.54	588.54	59.55	11.36	50	3.8131	2.9813	0.6073	0.7301	1.5912E+06
BF66-6B-100782-4	407.04	74.30	557.77	58.50	24.98	35	5.4783	2.8313	0.6040	0.7261	2.2950E+06
BF66-6B-100782-5	406.30	114.27	590.50	59.88	10.08	53	3.5556	2.9892	0.6005	0.7219	1.4828E+06
BF66-6B-100782-6	406.01	93.77	580.57	58.37	14.83	44	4.3298	2.9482	0.6072	0.7299	1.8108E+06
BF66-6B-100782-7	405.74	103.76	586.29	59.13	12.17	48	3.9103	2.9725	0.6028	0.7247	1.6329E+06
BF66-6B-100782-8	405.65	94.66	581.14	59.24	14.50	44	4.2853	2.9457	0.6080	0.7309	1.7900E+06
BF66-6B-100782-9	405.75	86.01	572.60	58.53	17.96	40	4.7175	2.9066	0.6055	0.7278	1.9738E+06

Note 1: Orifice meter pressure measured at the downstream flange tap and calculated as a simple average of N data samples during Draft Time.

Note 2: Flowing gas temperature measured downstream of the meter and calculated as a simple average of N data samples taken during Draft Time.

Note 3: Differential pressure measured between the flange taps and calculated as the square of the average of the square roots of N data samples taken during Draft Time.

Table 9(a). Test Meter Identification and Physical Measurements  
Nominal 6 Inch AGA/API Orifice Meter (British Units).

Test Identification	Test Configuration	Run Diameter (inches)	Orifice Diameter (inches)	Beta Ratio
BFE7-1A-020382-[10]	1982-B	6.0698	1.2490	0.2058
BFE7-1B-020582-[9]	1982-B	6.0698	1.2491	0.2058
BFE8-1A-012982-[8]	1982-B	6.0693	1.2490	0.2058
BFE8-1B-051282-[12]	1982-B	6.0693	1.2491	0.2058
BFE7-2A-020282-[9]	1982-B	6.0698	2.2499	0.3707
BFE7-2A-021182-[9]	1982-B	6.0698	2.2499	0.3707
BFE7-2B-020982-[10]	1982-B	6.0698	2.2500	0.3707
BFE7-2B-021082-[9]	1982-B	6.0698	2.2500	0.3707
BFE8-2A-012782-[9]	1982-B	6.0693	2.2499	0.3707
BFE7-3A-020482-[9]	1982-B	6.0698	3.0003	0.4943
BFE7-3A-021182-[9]	1982-B	6.0698	3.0003	0.4943
BFE7-3B-020382-[9]	1982-B	6.0698	3.0004	0.4943
BFE8-3A-051382-[12]	1982-B	6.0693	3.0003	0.4943
BFE8-3B-012782-[9]	1982-B	6.0693	3.0004	0.4944
BFE7-4A-020982-[9]	1982-B	6.0698	3.4994	0.5765
BFE7-4B-020482-[9]	1982-B	6.0698	3.4993	0.5765
BFE8-4A-051382-[12]	1982-B	6.0693	3.4994	0.5766
BFE8-4B-012982-[9]	1982-B	6.0693	3.4993	0.5766

Note: Test Identification bracket gives number of tests run with this geometry. A total of 172 tests were run on the nominal 6 inch run size.

Table 9(b). Test Number, Measured and Calculated Quantities  
Nominal 6 Inch AGA/API Orifice Meter (British Units).

Test Identification	Test Draft (lb)	Test Draft Time (s)	Press. Note 1 (psia)	Temp. Note 2 (°F)	Diff. Press. Note 3 (in H <sub>2</sub> O)	Data Samples N	Mass Flow Rate (lb/s)	Orifice Meter Density (lb/ft <sup>3</sup> )	CY <sub>2</sub>	KY <sub>1</sub>	Orifice Bore Rd
BFE7-1A-020382-1	428.29	307.67	609.51	57.01	70.78	132	1.3920	3.1047	0.6032	0.6037	1.3972E+06
BFE7-1A-020382-2	427.87	327.74	605.02	57.04	63.51	140	1.3055	3.0816	0.5995	0.6000	1.3108E+06
BFE7-1A-020382-3	427.46	231.60	597.21	57.51	128.26	99	1.8457	3.0386	0.6005	0.6010	1.8532E+06
BFE7-1A-020382-4	426.42	189.03	591.04	57.85	195.77	81	2.2558	3.0049	0.5973	0.5979	2.2651E+06
BFE7-1A-020382-5	427.55	312.33	597.04	57.70	70.07	134	1.3689	3.0365	0.6029	0.6034	1.3741E+06
BFE7-1A-020382-6	427.65	277.31	593.89	57.85	90.18	119	1.5421	3.0195	0.6003	0.6009	1.5481E+06
BFE7-1A-020382-7	427.80	338.71	592.90	57.44	59.66	145	1.2630	3.0171	0.6047	0.6053	1.2687E+06
BFE7-1A-020382-8	428.04	284.30	589.27	57.33	85.92	122	1.5056	2.9993	0.6024	0.6030	1.5131E+06
BFE7-1A-020382-9	427.95	402.29	596.12	56.64	42.59	172	1.0638	3.0387	0.6007	0.6012	1.0694E+06
BFE7-1A-020382-10	426.79	186.74	589.64	58.06	198.46	80	2.2855	2.9964	0.6019	0.6025	2.2945E+06
BFE7-1B-020582-1	380.26	235.12	601.12	60.57	98.04	101	1.6173	3.0386	0.6018	0.6023	1.6166E+06
BFE7-1B-020582-2	380.09	200.35	593.70	60.70	136.59	86	1.8971	3.0001	0.6018	0.6023	1.8972E+06
BFE7-1B-020582-3	380.34	301.98	599.17	60.60	59.43	129	1.2595	3.0286	0.6030	0.6035	1.2591E+06
BFE7-1B-020582-4	380.04	168.66	591.86	60.53	195.17	72	2.2533	2.9919	0.5988	0.5993	2.2542E+06
BFE7-1B-020582-5	380.89	269.66	596.66	60.64	75.52	115	1.4125	3.0156	0.6011	0.6016	1.4123E+06
BFE7-1B-020582-6	334.81	149.03	586.99	60.70	196.21	64	2.2466	2.9662	0.5980	0.5985	2.2479E+06
BFE7-1B-020582-7	372.63	271.02	595.62	61.01	71.91	116	1.3749	3.0079	0.6004	0.6010	1.3741E+06
BFE7-1B-020582-8	372.35	198.08	590.77	60.61	136.60	85	1.8798	2.9859	0.5977	0.5982	1.8805E+06
BFE7-1B-020582-9	372.60	332.85	598.13	60.67	46.60	142	1.1194	3.0228	0.6059	0.6065	1.1191E+06
BFE8-1A-012982-1	434.06	320.78	599.09	59.65	69.04	138	1.3532	3.0343	0.6005	0.6010	1.3546E+06
BFE8-1A-012982-2	433.72	236.38	588.92	60.06	128.67	101	1.8348	2.9800	0.6018	0.6023	1.8373E+06
BFE8-1A-012982-3	433.86	346.14	590.43	60.57	59.75	148	1.2534	2.9845	0.6029	0.6035	1.2541E+06
BFE8-1A-012982-4	433.23	197.44	576.30	60.37	190.29	85	2.1942	2.9140	0.5984	0.5990	2.1985E+06
BFE8-1A-012982-5	434.22	312.05	584.74	60.72	75.37	134	1.3915	2.9546	0.5990	0.5995	1.3926E+06
BFE8-1A-012982-6	434.29	290.42	582.40	60.43	86.30	124	1.4954	2.9446	0.6025	0.6030	1.4975E+06
BFE8-1A-012982-7	431.39	348.30	583.45	60.66	59.33	149	1.2386	2.9485	0.6016	0.6021	1.2398E+06
BFE8-1A-012982-8	430.55	277.41	581.95	60.66	95.35	119	1.5520	2.9409	0.5953	0.5958	1.5538E+06
BFE8-1B-051282-1	443.95	196.77	590.59	65.63	196.67	84	2.2562	2.9536	0.6010	0.6016	2.2422E+06
BFE8-1B-051282-2	444.93	249.43	594.96	65.91	121.35	107	1.7838	2.9737	0.6029	0.6035	1.7714E+06
BFE8-1B-051282-3	444.88	374.38	605.52	65.92	53.36	160	1.1883	3.0265	0.6005	0.6010	1.1790E+06
BFE8-1B-051282-4	444.39	285.08	598.98	66.18	92.66	122	1.5588	2.9921	0.6011	0.6017	1.5470E+06
BFE8-1B-051282-5	445.24	326.02	600.09	65.92	70.98	139	1.3657	2.9993	0.6011	0.6016	1.3556E+06
BFE8-1B-051282-6	444.71	195.95	587.59	65.97	199.41	84	2.2695	2.9364	0.6022	0.6027	2.2549E+06
BFE8-1B-051282-7	445.98	368.60	603.61	66.05	55.27	157	1.2099	3.0161	0.6019	0.6024	1.2005E+06
BFE8-1B-051282-8	445.91	331.92	600.36	65.65	68.65	141	1.3434	3.0024	0.6009	0.6014	1.3340E+06
BFE8-1B-051282-9	419.14	351.76	602.67	65.19	53.88	150	1.1915	3.0169	0.6003	0.6008	1.1837E+06
BFE8-1B-051282-10	418.58	272.27	598.01	64.99	90.22	116	1.5374	2.9947	0.6006	0.6011	1.5282E+06
BFE8-1B-051282-11	419.44	235.49	595.33	64.86	121.79	100	1.7811	2.9821	0.6001	0.6006	1.7712E+06
BFE8-1B-051282-12	420.29	386.98	601.29	64.71	44.49	165	1.0861	3.0129	0.6025	0.6030	1.0797E+06

Table 9(b) (cont.). Test Number, Measured and Calculated Quantities  
Nominal 6 Inch AGA/API Orifice Meter (British Units).

Test Identification	Test Draft (lb)	Test Draft Time (s)	Press. Note 1 (psia)	Temp. Note 2 (°F)	Diff. Press. Note 3 (in H <sub>2</sub> O)	Data Samples N	Mass Flow Rate (lb/s)	Orifice Meter Density (lb/ft <sup>3</sup> )	CY <sub>2</sub>	KY <sub>2</sub>	Orifice Bore Rd
BFEE7-2A-020282-1	414.24	177.67	587.54	59.69	19.26	76	2.3315	2.9754	0.6043	0.6101	1.2968E+06
BFEE7-2A-020282-2	414.82	243.98	592.12	59.49	10.22	104	1.7002	2.9999	0.6024	0.6082	9.4560E+05
BFEE7-2A-020282-3	395.04	206.76	589.37	59.46	12.93	89	1.9106	2.9861	0.6034	0.6091	1.0629E+06
BFEE7-2A-020282-4	395.20	74.81	541.70	62.32	109.95	32	5.2827	2.7273	0.5985	0.6043	2.9390E+06
BFEE7-2A-020282-5	395.15	127.89	582.77	60.20	34.54	55	3.0897	2.9479	0.6008	0.6065	1.7181E+06
BFEE7-2A-020282-6	359.82	91.88	572.33	60.70	56.85	39	3.9162	2.8919	0.5992	0.6050	2.1781E+06
BFEE7-2A-020282-7	359.95	155.21	581.61	60.62	19.69	66	2.3191	2.9394	0.5980	0.6038	1.2890E+06
BFEE7-2A-020282-8	360.24	212.76	589.70	60.47	10.12	91	1.6932	2.9814	0.6048	0.6106	9.4063E+05
BFEE7-2A-020282-9	360.15	185.23	590.15	60.46	13.46	79	1.9444	2.9837	0.6019	0.6076	1.0801E+06
BFEE7-2A-021182-1	418.21	202.86	609.26	63.07	14.79	85	2.0616	3.0636	0.6008	0.6066	1.1395E+06
BFEE7-2A-021182-2	418.23	76.75	563.68	67.61	111.40	32	5.4493	2.8071	0.6045	0.6103	3.0052E+06
BFEE7-2A-021182-3	417.35	130.63	600.08	63.68	36.21	55	3.1949	3.0134	0.6000	0.6058	1.7659E+06
BFEE7-2A-021182-4	417.44	102.29	582.54	63.35	61.18	43	4.0809	2.9272	0.5983	0.6040	2.2598E+06
BFEE7-2A-021182-5	417.40	253.43	602.36	63.68	9.31	106	1.6470	3.0249	0.6088	0.6146	9.1017E+05
BFEE7-2A-021182-6	417.95	78.18	547.80	61.01	109.91	33	5.3460	2.7657	0.6016	0.6074	2.9780E+06
BFEE7-2A-021182-7	416.71	103.30	574.89	64.25	61.43	43	4.0339	2.8832	0.5947	0.6004	2.2325E+06
BFEE7-2A-021182-8	417.02	176.48	589.97	63.18	20.24	74	2.3630	2.9657	0.5984	0.6041	1.3080E+06
BFEE7-2A-021182-9	417.16	138.19	583.61	62.92	33.17	58	3.0188	2.9352	0.6003	0.6060	1.6725E+06
BFEE7-2B-020982-1	420.28	213.64	608.36	62.88	13.49	91	1.9672	3.0603	0.6005	0.6063	1.0877E+06
BFEE7-2B-020982-2	420.68	76.58	557.78	63.35	115.21	33	5.4933	2.8024	0.5998	0.6055	3.0479E+06
BFEE7-2B-020982-3	420.08	136.07	596.89	62.92	33.83	58	3.0873	3.0022	0.6009	0.6067	1.7085E+06
BFEE7-2B-020982-4	419.57	102.64	582.27	62.74	61.11	44	4.0878	2.9296	0.5993	0.6051	2.2654E+06
BFEE7-2B-020982-5	420.99	249.87	603.36	63.33	9.95	107	1.6848	3.0322	0.6016	0.6074	9.3138E+05
BFEE7-2B-020982-6	421.20	77.93	549.77	62.49	112.91	33	5.4049	2.7670	0.5999	0.6056	3.0042E+06
BFEE7-2B-020982-7	420.13	103.25	580.34	63.34	61.19	44	4.0691	2.9162	0.5976	0.6033	2.2536E+06
BFEE7-2B-020982-8	419.29	172.29	596.36	62.47	21.43	74	2.4337	3.0024	0.5952	0.6009	1.3476E+06
BFEE7-2B-020982-9	419.27	138.55	590.73	62.13	33.09	59	3.0262	2.9761	0.5983	0.6040	1.6773E+06
BFEE7-2B-020982-10	418.77	178.32	595.45	62.48	19.66	76	2.3484	2.9977	0.6000	0.6058	1.3005E+06
BFEE7-2B-021082-1	418.18	216.09	599.20	63.16	13.20	93	1.9352	3.0123	0.6020	0.6078	1.0704E+06
BFEE7-2B-021082-2	417.89	76.85	547.34	64.97	114.96	33	5.4377	2.7405	0.6010	0.6067	3.0130E+06
BFEE7-2B-021082-3	416.83	134.37	586.95	62.43	34.61	58	3.1021	2.9551	0.6018	0.6075	1.7192E+06
BFEE7-2B-021082-4	417.28	104.45	574.40	62.61	59.00	45	3.9950	2.8906	0.6001	0.6059	2.2158E+06
BFEE7-2B-021082-5	417.75	249.37	593.42	63.43	10.15	107	1.6752	2.9814	0.5976	0.6033	9.2669E+05
BFEE7-2B-021082-6	418.00	77.50	544.46	60.19	113.28	33	5.3935	2.7535	0.5991	0.6049	3.0084E+06
BFEE7-2B-021082-7	416.78	104.00	575.89	62.68	60.25	44	4.0075	2.8978	0.5950	0.6007	2.2223E+06
BFEE7-2B-021082-8	417.16	173.72	588.41	62.81	20.97	74	2.4014	2.9601	0.5980	0.6037	1.3300E+06
BFEE7-2B-021082-9	416.58	136.25	584.14	62.66	34.10	58	3.0574	2.9395	0.5991	0.6048	1.6943E+06

Table 9(b) (cont.). Test Number, Measured and Calculated Quantities  
Nominal 6 Inch AGA/API Orifice Meter (British Units).

Test Identification	Test Draft (lb)	Test Draft Time (s)	Press. Note 1 (psia)	Temp. Note 2 (°F)	Diff. Press. Note 3 (in H <sub>2</sub> O)	Data Samples N	Mass Flow Rate (lb/s)	Orifice Meter Density (lb/ft <sup>3</sup> )	CY <sub>1</sub>	KY <sub>1</sub>	Orifice Bore Rd
BFE8-2A-012782-1	404.37	167.03	592.06	61.77	21.00	72	2.4210	2.9851	0.5999	0.6056	1.3424E+06
BFE8-2A-012782-2	406.50	250.56	603.11	61.47	9.29	107	1.6224	3.0429	0.5986	0.6043	8.9912E+05
BFE8-2A-012782-3	422.89	212.73	602.87	61.83	13.94	91	1.9879	3.0393	0.5991	0.6049	1.1012E+06
BFE8-2A-012782-4	424.50	77.89	552.29	59.33	113.10	33	5.4499	2.7984	0.6011	0.6068	3.0416E+06
BFE8-2A-012782-5	423.80	133.34	594.02	61.99	35.99	57	3.1783	2.9936	0.6008	0.6065	1.7615E+06
BFE8-2A-012782-6	422.44	104.49	580.10	62.19	59.73	45	4.0429	2.9220	0.6004	0.6061	2.2426E+06
BFE8-2A-012782-7	421.26	181.68	587.15	61.91	19.40	78	2.3187	2.9594	0.6004	0.6062	1.2860E+06
BFE8-2A-012782-8	424.65	260.93	591.34	61.77	9.32	112	1.6274	2.9814	0.6057	0.6115	9.0243E+05
BFE8-2A-012782-9	421.61	214.61	587.53	61.41	13.85	92	1.9645	2.9644	0.6016	0.6074	1.0902E+06
BFE7-3A-020482-1	443.89	81.92	550.14	61.91	34.51	35	5.4186	2.7723	0.5983	0.6170	2.2604E+06
BFE7-3A-020482-2	441.79	110.72	579.08	59.21	17.59	48	3.9902	2.9354	0.5997	0.6184	1.6666E+06
BFE7-3A-020482-3	441.66	126.31	583.68	60.63	13.51	54	3.4966	2.9499	0.5983	0.6170	1.4571E+06
BFE7-3A-020482-4	443.03	82.71	548.26	57.58	33.16	36	5.3564	2.7882	0.6018	0.6206	2.2477E+06
BFE7-3A-020482-5	442.26	132.47	585.96	60.00	12.02	57	3.3386	2.9654	0.6039	0.6228	1.3922E+06
BFE7-3A-020482-6	442.41	112.44	577.46	60.82	17.24	48	3.9346	2.9171	0.5993	0.6180	1.6400E+06
BFE7-3A-020482-7	442.13	146.80	586.62	60.37	9.90	63	3.0118	2.9664	0.6003	0.6191	1.2552E+06
BFE7-3A-020482-8	441.97	97.19	566.77	61.27	23.18	42	4.5475	2.8602	0.6032	0.6221	1.8960E+06
BFE7-3A-020482-9	442.27	125.25	581.23	60.14	13.95	54	3.5311	2.9405	0.5955	0.6141	1.4727E+06
BFE7-3A-021182-1	417.47	138.08	579.56	60.92	9.92	58	3.0234	2.9271	0.6059	0.6248	1.2598E+06
BFE7-3A-021182-2	417.43	108.14	572.14	60.63	16.52	45	3.8600	2.8913	0.6032	0.6221	1.6101E+06
BFE7-3A-021182-3	417.97	92.70	564.20	61.28	22.98	39	4.5088	2.8472	0.6020	0.6209	1.8803E+06
BFE7-3A-021182-4	418.78	118.53	574.78	61.43	13.79	50	3.5331	2.8998	0.6034	0.6223	1.4718E+06
BFE7-3A-021182-5	418.30	80.00	543.84	61.74	32.18	33	5.2288	2.7414	0.6012	0.6200	2.1827E+06
BFE7-3A-021182-6	417.89	128.16	576.99	61.57	11.70	54	3.2607	2.9102	0.6036	0.6224	1.3578E+06
BFE7-3A-021182-7	417.58	92.74	562.29	61.77	23.00	39	4.5027	2.8345	0.6022	0.6211	1.8768E+06
BFE7-3A-021182-8	417.70	130.24	574.51	61.61	11.46	55	3.2071	2.8973	0.6011	0.6199	1.3357E+06
BFE7-3A-021182-9	418.43	137.74	575.35	60.86	10.24	58	3.0378	2.9062	0.6014	0.6202	1.2664E+06
BFE7-3B-020382-1	426.80	139.61	585.39	59.02	9.99	60	3.0571	2.9687	0.6062	0.6252	1.2765E+06
BFE7-3B-020382-2	427.00	107.83	576.27	59.60	17.16	46	3.9599	2.9187	0.6044	0.6233	1.6534E+06
BFE7-3B-020382-3	426.78	94.95	568.20	59.66	22.53	41	4.4948	2.8773	0.6029	0.6218	1.8778E+06
BFE7-3B-020382-4	426.74	120.08	577.59	59.93	13.91	52	3.5538	2.9233	0.6019	0.6207	1.4830E+06
BFE7-3B-020382-5	426.79	81.19	541.62	60.37	32.68	35	5.2567	2.7381	0.6002	0.6189	2.1987E+06
BFE7-3B-020382-6	426.87	133.33	575.47	59.40	11.34	57	3.2016	2.9158	0.6012	0.6200	1.3372E+06
BFE7-3B-020382-7	426.88	97.07	564.06	59.07	21.71	42	4.3976	2.8598	0.6027	0.6215	1.8393E+06
BFE7-3B-020382-8	426.71	131.08	575.71	59.23	11.74	56	3.2553	2.9181	0.6007	0.6195	1.3599E+06
BFE7-3B-020382-9	426.82	143.44	576.96	59.44	9.77	61	2.9756	2.9232	0.6014	0.6202	1.2426E+06

Table 9(b) (cont.). Test Number, Measured and Calculated Quantities  
Nominal 6 Inch AGA/API Orifice Meter (British Units).

Test Identification	Test Draft (lb)	Test Draft Time (s)	Press. Note 1 (psia)	Temp. Note 2 (°F)	Diff. Press. Note 3 (in H <sub>2</sub> O)	Data Samples N	Mass Flow Rate (lb/s)	Orifice Meter Density (lb/ft <sup>3</sup> )	CY <sub>2</sub>	KY <sub>2</sub>	Orifice Bore R <sub>d</sub>
BFE8-3A-051382-1	420.49	116.72	585.78	63.94	14.22	50	3.6026	2.9398	0.6016	0.6204	1.4944E+06
BFE8-3A-051382-2	420.42	92.55	575.40	63.78	23.01	40	4.5426	2.8885	0.6017	0.6205	1.8863E+06
BFE8-3A-051382-3	420.75	76.47	551.43	65.48	35.27	33	5.5022	2.7581	0.6025	0.6214	2.2841E+06
BFE8-3A-051382-4	419.74	130.94	584.33	64.96	11.30	56	3.2056	2.9263	0.6021	0.6209	1.3281E+06
BFE8-3A-051382-5	450.71	115.60	577.01	63.91	16.91	50	3.8989	2.8958	0.6017	0.6205	1.6186E+06
BFE8-3A-051382-6	450.84	100.92	570.37	63.97	22.43	43	4.4673	2.8621	0.6022	0.6210	1.8554E+06
BFE8-3A-051382-7	451.59	82.66	543.33	64.41	35.22	35	5.4632	2.7236	0.6024	0.6213	2.2726E+06
BFE8-3A-051382-8	450.89	149.20	586.04	64.77	10.13	64	3.0220	2.9360	0.5985	0.6172	1.2522E+06
BFE8-3A-051382-9	450.91	137.54	583.91	64.59	11.89	59	3.2784	2.9264	0.6002	0.6190	1.3590E+06
BFE8-3A-051382-10	450.82	127.40	583.14	64.82	13.70	55	3.5387	2.9211	0.6040	0.6229	1.4665E+06
BFE8-3A-051382-11	450.84	114.14	578.18	64.20	17.35	49	3.9499	2.9000	0.6014	0.6202	1.6390E+06
BFE8-3A-051382-12	450.91	148.78	586.77	64.81	9.88	64	3.0307	2.9394	0.6074	0.6264	1.2557E+06
BFE8-3B-012782-1	424.78	140.09	590.53	60.95	9.88	60	3.0322	2.9825	0.6033	0.6222	1.2623E+06
BFE8-3B-012782-2	423.80	105.79	581.16	61.48	17.45	45	4.0060	2.9318	0.6049	0.6238	1.6678E+06
BFE8-3B-012782-3	424.64	93.83	569.22	61.38	22.99	40	4.5256	2.8720	0.6015	0.6203	1.8862E+06
BFE8-3B-012782-4	426.56	121.32	583.64	61.68	13.56	52	3.5160	2.9431	0.6010	0.6198	1.4631E+06
BFE8-3B-012782-5	424.28	78.75	546.14	62.06	33.91	34	5.3877	2.7512	0.6024	0.6212	2.2476E+06
BFE8-3B-012782-6	423.04	127.52	584.00	61.02	11.97	55	3.3175	2.9491	0.6030	0.6218	1.3816E+06
BFE8-3B-012782-7	423.13	93.33	568.54	60.80	23.07	40	4.5337	2.8720	0.6015	0.6204	1.8911E+06
BFE8-3B-012782-8	424.35	126.81	581.80	60.49	12.14	54	3.3463	2.9412	0.6048	0.6237	1.3949E+06
BFE8-3B-012782-9	424.99	141.08	581.29	60.64	9.94	60	3.0124	2.9376	0.6020	0.6208	1.2555E+06
BFE7-4A-020982-1	409.85	81.84	564.15	63.75	14.55	35	5.0079	2.8322	0.6023	0.6386	1.7847E+06
BFE7-4A-020982-2	410.62	87.38	568.41	60.56	12.57	38	4.6993	2.8728	0.6038	0.6402	1.6812E+06
BFE7-4A-020982-3	410.18	90.12	571.81	62.07	11.77	39	4.5515	2.8808	0.6036	0.6400	1.6246E+06
BFE7-4A-020982-4	381.43	76.22	561.38	61.82	14.56	33	5.0043	2.8297	0.6020	0.6383	1.7884E+06
BFE7-4A-020982-5	376.32	71.21	551.08	60.46	16.44	30	5.2846	2.7856	0.6029	0.6393	1.8935E+06
BFE7-4A-020982-6	376.74	80.52	564.69	61.09	12.65	34	4.6789	2.8508	0.6016	0.6378	1.6733E+06
BFE7-4A-020982-7	360.23	83.55	571.31	63.59	10.76	36	4.3116	2.8692	0.5990	0.6351	1.5359E+06
BFE7-4A-020982-8	359.90	84.68	572.40	63.24	10.33	36	4.2501	2.8767	0.6020	0.6383	1.5146E+06
BFE7-4A-020982-9	360.20	83.71	570.47	63.82	10.64	36	4.3030	2.8635	0.6018	0.6381	1.5325E+06
BFE7-4B-020482-1	425.85	91.31	571.48	60.65	12.32	39	4.6638	2.8878	0.6037	0.6401	1.6680E+06
BFE7-4B-020482-2	425.51	96.84	576.10	60.71	10.83	42	4.3940	2.9109	0.6043	0.6407	1.5707E+06
BFE7-4B-020482-3	426.53	100.37	575.89	62.66	10.27	43	4.2496	2.8979	0.6014	0.6376	1.5152E+06
BFE7-4B-020482-4	425.97	80.00	545.41	60.50	16.86	34	5.3246	2.7565	0.6032	0.6396	1.9087E+06
BFE7-4B-020482-5	426.05	85.75	559.73	61.67	14.41	37	4.9685	2.8222	0.6016	0.6378	1.7762E+06
BFE7-4B-020482-6	425.85	79.90	545.30	58.65	16.90	34	5.3298	2.7668	0.6019	0.6381	1.9154E+06
BFE7-4B-020482-7	425.86	93.86	570.35	61.98	11.79	40	4.5372	2.8740	0.6019	0.6382	1.6200E+06
BFE7-4B-020482-8	425.71	100.09	571.48	62.41	10.30	43	4.2532	2.8772	0.6032	0.6396	1.5176E+06
BFE7-4B-020482-9	425.65	95.47	567.85	62.48	11.43	41	4.4585	2.8584	0.6022	0.6385	1.5911E+06

Table 9(b) (cont.). Test Number, Measured and Calculated Quantities  
Nominal 6 Inch AGA/API Orifice Meter (British Units).

Test Identification	Test Draft (lb)	Test Draft Time (s)	Press. Note 1 (psia)	Temp. Note 2 (°F)	Diff. Press. Note 3 (in H <sub>2</sub> O)	Data Samples N	Mass Flow Rate (lb/s)	Orifice Meter Density (lb/ft <sup>3</sup> )	CY <sub>2</sub>	KY <sub>2</sub>	Orifice Bore	
											R <sub>d</sub>	R <sub>d</sub>
BFE8-4A-051382-1	452.16	105.64	569.84	64.15	10.39	45	4.2802	2.8584	0.6064	0.6430	1.5238E+06	1.5238E+06
BFE8-4A-051382-2	451.14	100.89	570.08	63.80	11.41	43	4.4716	2.8616	0.6043	0.6407	1.5927E+06	1.5927E+06
BFE8-4A-051382-3	451.83	83.62	547.14	62.65	17.34	36	5.4034	2.7529	0.6039	0.6403	1.9311E+06	1.9311E+06
BFE8-4A-051382-4	451.13	105.41	569.82	64.64	10.65	45	4.2798	2.8553	0.5991	0.6353	1.5227E+06	1.5227E+06
BFE8-4A-051382-5	450.93	90.86	558.14	63.93	14.42	39	4.962 <sup>o</sup>	2.8008	0.6030	0.6393	1.7691E+06	1.7691E+06
BFE8-4A-051382-6	450.08	96.07	563.56	62.69	12.59	41	4.6849	2.8355	0.6053	0.6418	1.6720E+06	1.6720E+06
BFE8-4A-051382-7	452.08	84.44	547.51	63.55	17.07	36	5.3539	2.7495	0.6034	0.6397	1.9110E+06	1.9110E+06
BFE8-4A-051382-8	451.26	92.00	552.85	63.64	14.29	39	4.9050	2.7758	0.6014	0.6376	1.7498E+06	1.7498E+06
BFE8-4A-051382-9	451.42	104.64	564.00	65.06	10.76	45	4.3140	2.8236	0.6043	0.6407	1.5347E+06	1.5347E+06
BFE8-4A-051382-10	451.33	98.94	571.10	62.85	11.65	42	4.5616	2.8726	0.6088	0.6455	1.6267E+06	1.6267E+06
BFE8-4A-051382-11	451.13	104.93	577.39	63.21	10.38	45	4.2994	2.9021	0.6047	0.6411	1.5316E+06	1.5316E+06
BFE8-4A-051382-12	451.45	96.26	570.23	64.09	12.74	41	4.6899	2.8607	0.5999	0.6361	1.6698E+06	1.6698E+06
BFE8-4B-012982-1	406.60	84.90	571.74	60.03	12.99	37	4.7891	2.8930	0.6033	0.6397	1.7142E+06	1.7142E+06
BFE8-4B-012982-2	406.64	92.01	575.43	60.89	11.00	40	4.4195	2.9065	0.6036	0.6399	1.5796E+06	1.5796E+06
BFE8-4B-012982-3	406.32	93.74	574.85	60.33	10.59	40	4.3345	2.9069	0.6032	0.6395	1.5504E+06	1.5504E+06
BFE8-4B-012982-4	406.63	75.14	543.51	61.53	17.44	32	5.4116	2.7410	0.6045	0.6409	1.9375E+06	1.9375E+06
BFE8-4B-012982-5	406.74	83.05	553.67	60.54	14.10	36	4.8975	2.7982	0.6020	0.6383	1.7543E+06	1.7543E+06
BFE8-4B-012982-6	414.50	77.59	542.58	61.71	17.07	33	5.3421	2.7352	0.6037	0.6401	1.9123E+06	1.9123E+06
BFE8-4B-012982-7	414.00	93.75	565.92	61.10	11.30	40	4.4160	2.8570	0.6000	0.6362	1.5791E+06	1.5791E+06
BFE8-4B-012982-8	413.64	97.42	567.36	60.37	10.31	42	4.2459	2.8687	0.6028	0.6391	1.5196E+06	1.5196E+06
BFE8-4B-012982-9	413.44	92.67	563.87	60.35	11.38	40	4.4614	2.8511	0.6048	0.6413	1.5972E+06	1.5972E+06

Note 1: Orifice meter pressure measured at the downstream flange tap and calculated as a simple average of N data samples during Draft Time.

Note 2: Flowing gas temperature measured downstream of the meter and calculated as a simple average of N data samples taken during Draft Time.

Note 3: Differential pressure measured between the flange taps and calculated as the square of the average of the square roots of N data samples taken during Draft Time.

## REFERENCES CITED

1. Dean, J. W., J. A. Brennan, D. B. Mann and C. H. Kneebone, Cryogenic flow research facility provisional accuracy statement, Nat. Bur. Stand. (U.S.) Tech. Note 606, (1971).
2. Mann, D. B., and J. A. Brennan, On a new method of gas flow measurement using cryogenic techniques, Nat. Bur. Stand. (U.S.) Special Pub. 484, vol. 2, pp 881-93, (1977).
3. A magnetic tape containing all measured published data in SI units is available at cost of reproduction from Chemical Engineering Science Division, Chemical Engineering Center, National Bureau of Standards, Boulder, CO 80303.
4. Mann, D. B., J. A. Brennan, C. F. Sindt, J. F. LaBrecque and C. H. Kneebone, Gas orifice meter performance with new flow reference system, Proceedings of 1983 Int. Gas Research Conf., London, UK, (June 12-16, 1983).
5. Powell, R. L., W. J. Hall, C. H. Hyink and L. L. Sparks, Thermocouple reference tables based on IPTS-68, Nat. Bur. Stand. (U.S.) Monograph 125 (1974).
6. American National Standards Institute, ANSI/API 2530, Orifice metering of natural gas, American Gas Association, 1515 Wilson Boulevard, Arlington, VA 22209, (1978).
7. Younglove, B. A., Thermophysical properties of fluids. 1. argon, ethylene, parahydrogen, nitrogen, nitrogen trifluoride, and oxygen, J. Physical and Chemical Reference Data, 11, Supplement No. 1, (1982).
8. American Society of Mechanical Engineers, Fluid meters, their theory and application, 6th Ed., American Society of Mechanical Engineers, 345 East 47th Street, NY, NY, pp 181-82, (1971).
9. Sprenkle, R. E., and N. S. Courtright, Straightening vanes for flow measurement, Mechanical Engineering, 80, 71-73, (February, 1958).
10. Sindt, C. F., and J. F. LaBrecque, An accuracy statement for a facility used to calibrate static pressure transducers and differential pressure transducers at high base pressure, Nat. Bur. Stand. (U.S.) Tech. Note. 1052, 1982.
11. Kell, G. S., Density, Thermal expansivity, and compressibility of liquid water from 0° to 150°C. Correlations and tables for atmospheric pressure and saturation reviewed and expressed on 1968 temperature scale, J. Chem & Eng Data, 20, 97-105, (1975).
12. International Standards Organization, Standard 5167, Measurements of fluid flow by means of orifice plates, nozzles and venturi tubes installed in circular cross-section conduits", ISO 5167 (1980 E), Geneva, (1980).
13. Beitler, S. R., The flow of water through orifices, The Ohio State University, the Engineering Experiment Station Bulletin 89, 73pp. (May 1935).



## APPENDIX I.

### Measurements of Orifice Meter Runs

The orifice meter runs were measured at NBS-Boulder, Colorado. The lengths were measured with a commercial steel tape. The inside diameters were measured with inside micrometers. Location of orifice taps and dowel pins were determined by inserting precision ground rods in the holes and measuring the distance from the rods to the flange face or flange hole with micrometers. The dowel pin location listed is the radius from the flange center line to the center line of the dowel hole. The radius used for the flange hole was the average of the four radii measured at the flange tap as shown in columns C and D on the following charts.

The surface finish listed for the upstream tube is, first, the finish alongside the flange tap hole and, second, the finish upstream from the flange face as far as the instrument would reach, about 12 cm.

The orifice meters are identified with an impression stamp either on the flanges or on the pipe. Identification of the meter runs included the two leading letters FE followed by a number which identifies the meter assembly. The number is followed by a letter which identifies the meter section. The letter A is used for the approach section; B is used for the upstream section and C is used for the downstream section. The number identification for size uses 1 and 2 for the two inch nominal meter, 3 and 4 for the three inch meter, 5 and 6 for the four inch meter and 7 and 8 for the six inch meter. An example of the identification would be FE6-A, which is for a four inch approach section.

## ORIFICE METER TUBE MEASUREMENTS

Meter Size (nom.) 2 inch

Meter Ident. FE 1

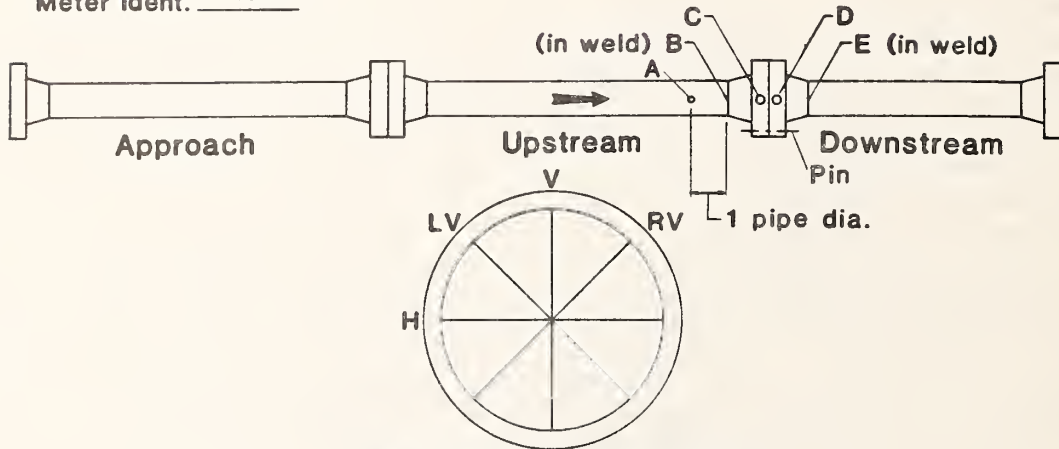

View In Direction Of Flow

	Upstream Tube						Downstream Tube			
	A		B		C		D		E	
	cm	in	cm	in	cm	in	cm	in	cm	in
<b>V</b>	5.250	2.067	5.2481	2.0662	5.2532	2.0682	5.2446	2.0648	5.2413	2.0635
<b>LV</b>	5.250	2.067	5.2532	2.0682	5.2515	2.0675	5.2489	2.0665	5.2421	2.0638
<b>RV</b>	5.248	2.067	5.2471	2.0658	5.2497	2.0668	5.2514	2.0675	5.2405	2.0632
<b>H</b>	5.250	2.067	5.2489	2.0665	5.2532	2.0682	5.2551	2.0650	5.2456	2.0652
<b>Avg.</b>	5.249	2.067	5.2493	2.0667	5.2519	2.0677	5.2475	2.0660	5.2424	2.0639

	<u>Upstream</u>	<u>Downstream</u>
Tap Location cm (in) (from flange face)	2.564 (1.010)	2.550 (1.004)
Pin Location cm (in) Pin #1	5.905 (2.325)	5.878 (2.314)
Pin #2	5.887 (2.318)	5.878 (2.314)
Tap Diameter cm (in) Top	0.960 (0.378)	0.960 (0.378)
Bottom	0.963 (0.379)	0.960 (0.378)
Surface Finish $\mu\text{m}$ ( $\mu\text{in}$ )	7.0 (275)	
Tube Length cm (in)		
Approach Tube	177.00 (69.68)	
Upstream Tube	45.24 (17.81)	
Downstream Tube	106.52 (41.93)	

## ORIFICE METER TUBE MEASUREMENTS

Meter Size (nom.) 2 inch

Meter Ident. FE 2

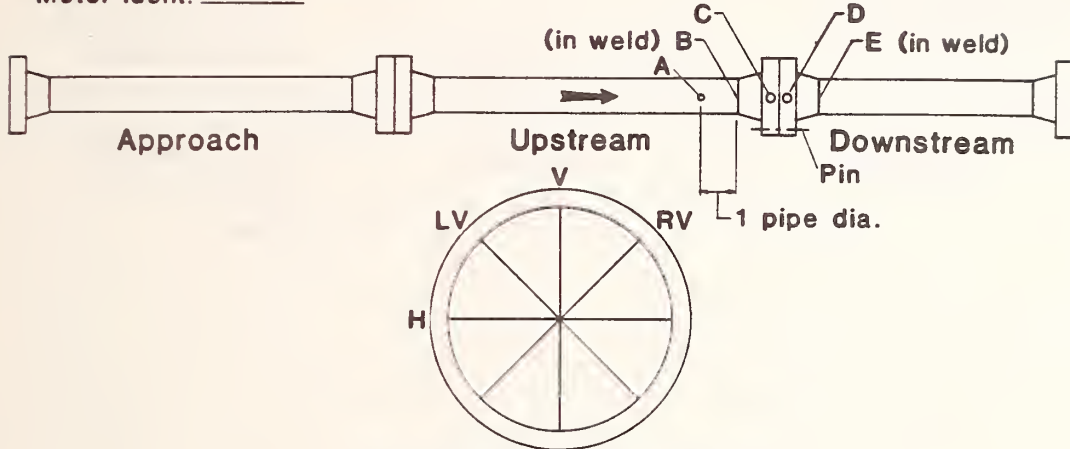

View In Direction Of Flow

	Upstream Tube						Downstream Tube			
	A		B		C		D		E	
	cm	in	cm	in	cm	in	cm	in	cm	in
<b>V</b>	5.253	2.068	5.2608	2.0712	5.2583	2.0702	5.2456	2.0652	5.2413	2.0635
<b>LV</b>	5.248	2.066	5.2497	2.0668	5.2608	2.0712	5.2476	2.0660	5.2431	2.0642
<b>RV</b>	5.248	2.066	5.2608	2.0712	5.2624	2.0718	5.2431	2.0642	5.2446	2.0648
<b>H</b>	5.250	2.067	5.2565	2.0695	5.2578	2.0700	5.2426	2.0640	5.2438	2.0645
<b>Avg.</b>	5.250	2.067	5.2570	2.0697	5.2598	2.0708	5.2447	2.0649	5.2432	2.0643

	Upstream	Downstream
Tap Location cm (in) (from flange face)	2.565-2.569 (1.010-1.012)	2.549-2.555 (1.004 -1.006)
Pin Location cm (in) Pin #1	5.901 (2.323)	5.899 (2.322)
Pin #2	5.909 (2.326)	5.889 (2.318)
Tap Diameter cm (in) Top	0.960 (0.378)	0.960 (0.378)
Bottom	0.963 (0.379)	0.958 (0.377)
Surface Finish $\mu\text{m}$ ( $\mu\text{in}$ )	2.5 (98)	
	4.5 (177)	
Tube Length cm (in)		
Approach Tube	177.16 (69.75)	
Upstream Tube	45.56 (17.93)	
Downstream Tube	106.52 (41.93)	

## ORIFICE METER TUBE MEASUREMENTS

Meter Size (nom.) 3 inch

Meter Ident. FE3

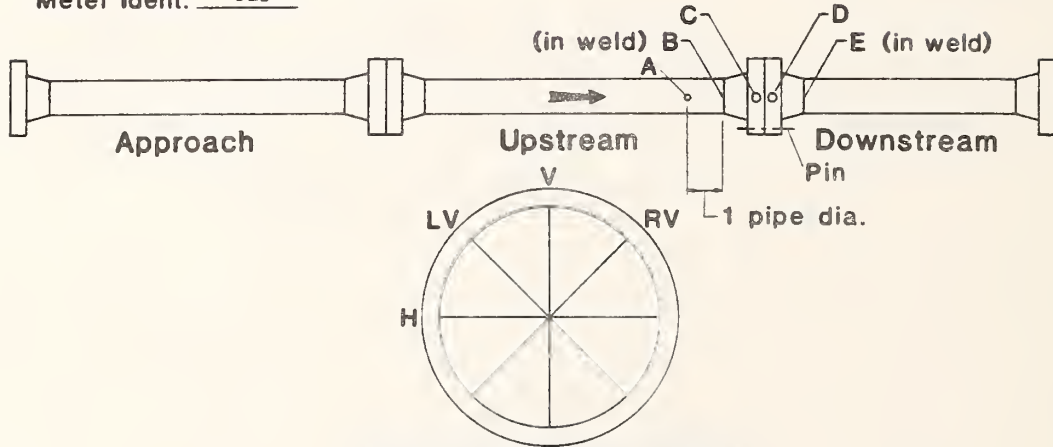

View In Direction Of Flow

	Upstream Tube						Downstream Tube			
	A		B		C		D		E	
	cm	in	cm	in	cm	in	cm	in	cm	in
<b>V</b>	7.798	3.070	7.7927	3.0680	7.7914	3.0675	7.7983	3.0702	7.8041	3.0725
<b>LV</b>	7.803	3.072	7.7935	3.0683	7.7953	3.0690	7.7978	3.0700	7.8003	3.0710
<b>RV</b>	7.785	3.065	7.7927	3.0680	7.7922	3.0678	7.8026	3.0719	7.8008	3.0712
<b>H</b>	7.803	3.072	7.7826	3.0640	7.7915	3.0675	7.8000	3.0710	7.7914	3.0675
<b>Avg.</b>	7.797	3.070	7.7904	3.0671	7.7926	3.0679	7.7991	3.0708	7.7992	3.0706

	<u>Upstream</u>	<u>Downstream</u>
Tap Location cm (in) (from flange face)	2.536-2.539 (0.999-1.000)	2.558 (1.007)
Pin Location cm (in) Pin #1 Pin #2	7.770(3.059) 7.770(3.059)	7.794(3.068) 7.794(3.068)
Tap Diameter cm (in) Top Bottom	0.965(0.380) 0.963(0.379)	0.965(0.380) 0.963(0.379)
Surface Finish $\mu\text{m}$ ( $\mu\text{in}$ )	2.0 (78) 4.0(157)	
Tube Length cm (in)		
Approach Tube	265.91(104.68)	
Upstream Tube	68.42 (26.93)	
Downstream Tube	137.00 (53.93)	

## ORIFICE METER TUBE MEASUREMENTS

Meter Size (nom.) 3 inch

Meter Ident. FE4

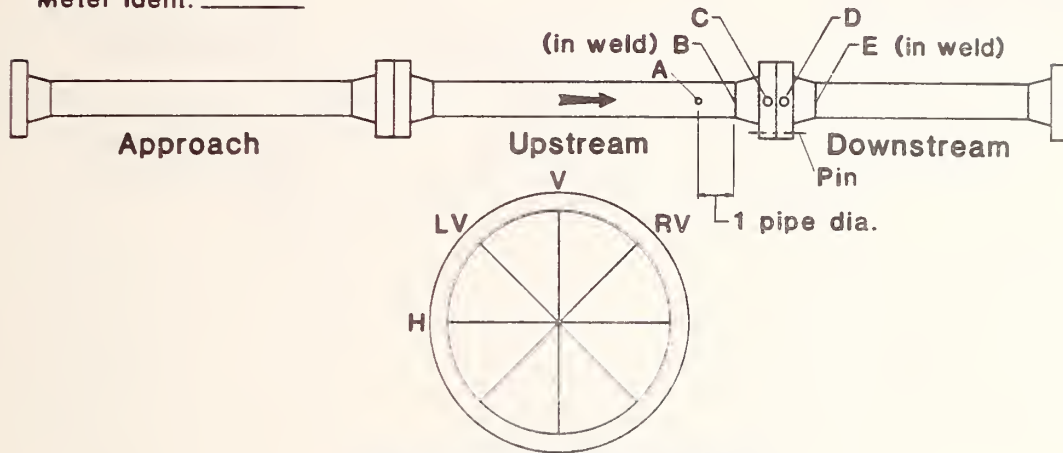

View In Direction Of Flow

	Upstream Tube						Downstream Tube			
	A		B		C		D		E	
	cm	in	cm	in	cm	in	cm	in	cm	in
<b>V</b>	7.805	3.073	7.7914	3.0675	7.7958	3.0692	7.7998	3.0708	7.7907	3.0672
<b>LV</b>	7.818	3.078	7.7838	3.0645	7.7876	3.0660	7.7978	3.0700	7.7864	3.0655
<b>RV</b>	7.762	3.056	7.7864	3.0655	7.7948	3.0688	7.8003	3.0710	7.7958	3.0692
<b>H</b>	7.821	3.079	7.7914	3.0675	7.7902	3.0670	7.7983	3.0702	7.7889	3.0665
<b>Avg.</b>	7.802	3.072	7.7883	3.0663	7.7921	3.0678	7.7991	3.0705	7.7905	3.0671

	<u>Upstream</u>	<u>Downstream</u>
Tap Location cm (in) (from flange face)	2.553-2.560 (1.005-1.008)	2.547 (1.003)
Pin Location cm (in) Pin #1 Pin #2	7.787(3.066) 7.782(3.064)	7.798(3.070) 7.793(3.068)
Tap Diameter cm (in) Top Bottom	0.963(0.379) 0.959(0.3775)	0.960(0.378) 0.968(0.381)
Surface Finish $\mu\text{m}$ ( $\mu\text{in}$ )	9.0 (354) 7.75(305)	
Tube Length cm (in) Approach Tube Upstream Tube Downstream Tube	266.07(104.75) 68.74 (27.06) 137.16 (54.00)	

## ORIFICE METER TUBE MEASUREMENTS

Meter Size (nom.) 4 inch

Meter Ident. FE 5

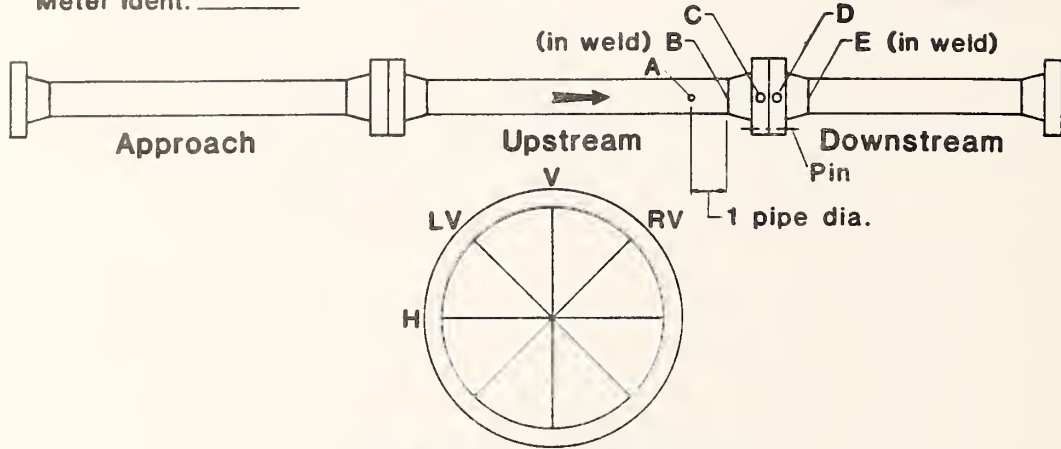

View In Direction Of Flow

	Upstream Tube						Downstream Tube			
	A		B		C		D		E	
	cm	in	cm	in	cm	in	cm	in	cm	in
V	--	--	10.2273	4.0265	10.2222	4.0245	10.2222	4.0245	10.2062	4.0182
LV	--	--	10.2171	4.0225	10.2108	4.0200	10.2205	4.0238	10.2095	4.0195
RV	--	--	10.2222	4.0245	10.2113	4.0202	10.2171	4.0225	10.2215	4.0242
H	--	--	10.2210	4.0240	10.2222	4.0245	10.2184	4.0230	10.2095	4.0195
Avg.	10.216	4.022	10.2219	4.0244	10.2166	4.0223	10.2196	4.0235	10.2117	4.0204

	<u>Upstream</u>	<u>Downstream</u>
Tap Location cm (in) (from flange face)	2.548-2.555 (1.003-1.006)	2.553 (1.005)
Pin Location cm (in) Pin #1 Pin #2		
Tap Diameter cm (in) Top Bottom		
Surface Finish $\mu\text{m}$ ( $\mu\text{in}$ )	<u>2.5-5.0 (98-197)</u>	
Tube Length cm (in)		
Approach Tube	<u>355.12 (139.81)</u>	
Upstream Tube	<u>91.44 (36.00)</u>	
Downstream Tube	<u>167.48 (65.93)</u>	

## ORIFICE METER TUBE MEASUREMENTS

Meter Size (nom.) 4 inch

Meter Ident. FE 6

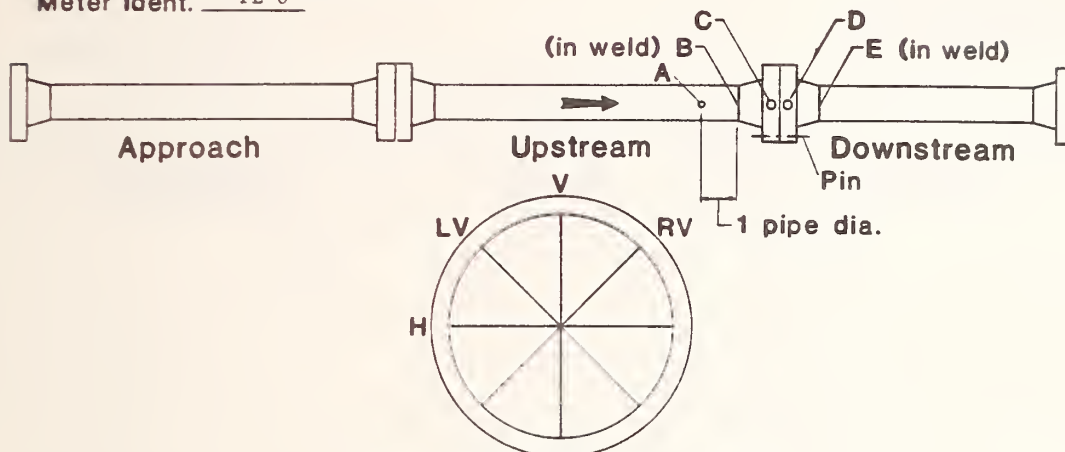

View In Direction Of Flow

	Upstream Tube						Downstream Tube			
	A		B		C		D		E	
	cm	in	cm	in	cm	in	cm	in	cm	in
<b>V</b>	10.236	4.030	10.2265	4.0262	10.2349	4.0295	10.2248	4.0255	10.2184	4.0230
<b>LV</b>	10.229	4.027	10.2331	4.0288	10.2222	4.0245	10.2235	4.0250	10.2095	4.0195
<b>RV</b>	10.234	4.029	10.2248	4.0255	10.2204	4.0238	10.2306	4.0278	10.2342	4.0292
<b>H</b>	10.234	4.027	10.2306	4.0278	10.2265	4.0262	10.2215	4.0242	10.2159	4.0220
<b>Avg.</b>	10.233	4.028	10.2288	4.0271	10.2260	4.0260	10.2222	4.0256	10.2195	4.0234

	Upstream	Downstream
Tap Location cm (in) (from flange face)	2.553-2.560 (1.005-1.008)	2.550-2.555 (1.004-1.006)
Pin Location cm (in) Pin #1	9.505 (3.742)	9.517 (3.747)
Pin #2	9.492 (3.737)	9.568 (3.767)
Tap Diameter cm (in) Top	1.273 (.501)	1.295 (.510)
Bottom	1.271 (.502)	1.290 (.508)
Surface Finish $\mu\text{m}$ ( $\mu\text{in}$ )	2.5-4.5 (98-177)	
Tube Length cm (in)	3.0-8.0 (118-315)	
Approach Tube	355.28 (139.8)	
Upstream Tube	91.12 (35.87)	
Downstream Tube	167.48 (65.93)	

## ORIFICE METER TUBE MEASUREMENTS

Meter Size (nom.) 6 inch

Meter Ident. FE 7

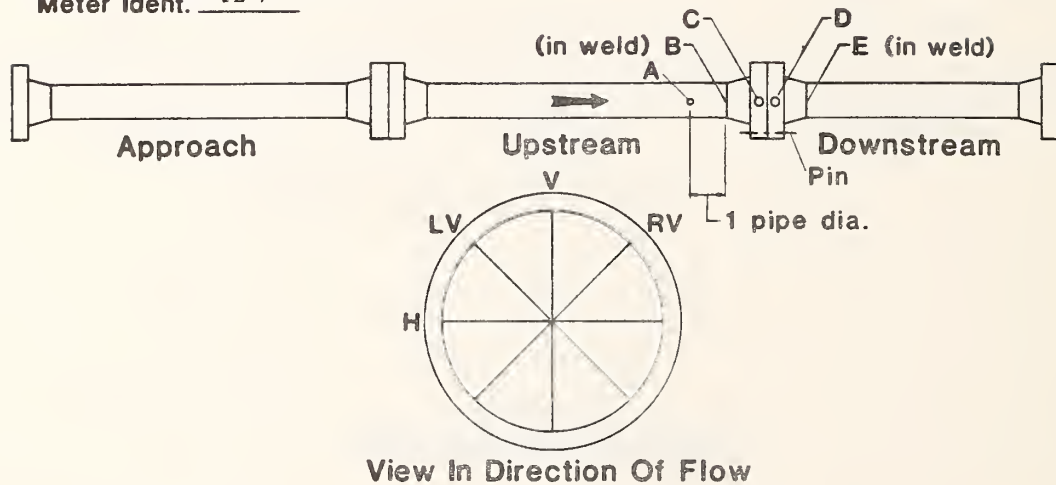

	Upstream Tube						Downstream Tube			
	A		B		C		D		E	
	cm	in	cm	in	cm	in	cm	in	cm	in
V	--	--	15.4224	6.0718	15.4165	6.0695	15.4148	6.0688	15.4285	6.0742
LV	--	--	15.4249	6.0728	15.4178	6.0700	15.4155	6.0691	15.4432	6.0800
RV	--	--	15.4178	6.0700	15.4178	6.0700	15.4140	6.0685	15.4292	6.0745
H	--	--	15.4229	6.0720	15.4173	6.0698	15.4153	6.0690	15.4407	6.0790
<b>Avg.</b>	15.433	6.076	15.4220	6.0717	15.4174	6.0698	15.4149	6.0689	15.4354	6.0769

	<u>Upstream</u>	<u>Downstream</u>
Tap Location cm (in) (from flange face)	2.535 (0.998)	2.549-2.558 (1.004-1.007)
Pin Location cm (in) Pin #1	13.016 (5.124)	13.019 (5.126)
Pin #2	13.010 (5.121)	13.021 (5.127)
Tap Diameter cm (in) Top	1.280 (0.504)	1.283 (0.505)
Bottom	1.273 (0.501)	1.280 (0.504)
Surface Finish $\mu\text{m}$ ( $\mu\text{in}$ )	1.85 (72)	
Tube Length cm (in)	4.5 (177)	
Approach Tube	531.34 (209.18)	
Upstream Tube	137.16 (54.0)	
Downstream Tube	228.44 (89.93)	



## ORIFICE METER TUBE MEASUREMENTS

Meter Size (nom.) 6 inch

Meter Ident. FE 8

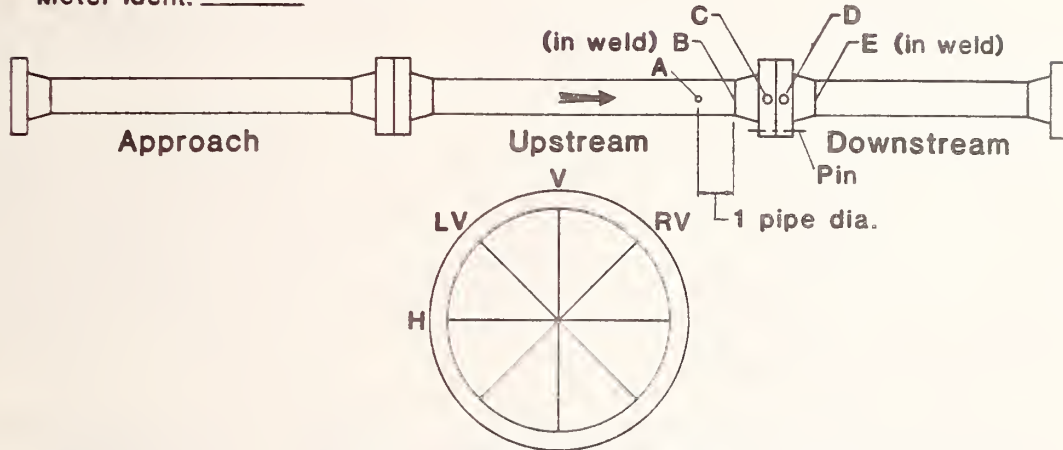

View In Direction Of Flow

	Upstream Tube						Downstream Tube			
	A		B		C		D		E	
	cm	in	cm	in	cm	in	cm	in	cm	in
<b>V</b>	15.471	6.091	15.4325	6.0758	15.4153	6.0690	15.4107	6.0672	15.4165	6.0695
<b>LV</b>	15.474	6.092	15.4224	6.0718	15.4165	6.0695	15.4081	6.0662	15.4457	6.0810
<b>RV</b>	15.469	6.090	15.4259	6.0732	15.4148	6.0688	15.4076	6.0660	15.4254	6.0730
<b>H</b>	15.474	6.092	15.4234	6.0722	15.4173	6.0698	15.4076	6.0660	15.4381	6.0780
<b>Avg.</b>	15.472	6.091	15.4261	6.0733	15.4160	6.0693	15.4085	6.0664	15.4314	6.0754

Tap Location cm (in)  
(from flange face)

Pin Location cm (in)

Pin #1  
Pin #2

Tap Diameter cm (in)

Top  
Bottom

Surface Finish  $\mu\text{m}$  ( $\mu\text{in}$ ) 5.5 (216)

Tube Length cm (in)  
 Approach Tube 531.50 (209.25)  
 Upstream Tube 137.00 (53.93)  
 Downstream Tube 228.44 (89.93)

Upstream	Downstream
2.504-2.558 (1.000-1.007)	2.809-2.794 (1.106-1.100)
13.011 (5.123)	13.023 (5.127)
13.019 (5.126)	13.021 (5.126)
1.280 (0.504)	1.285 (0.506)
1.280 (0.504)	1.275 (0.502)

## APPENDIX II.

### Measurements of Orifice Plates

The orifice plates were measured at NBS-Boulder, Colorado. The diameters and the concentricity of the orifice to the plate outside diameter were measured with an optical measuring device. The outside diameter was first determined then the center of the plate was calculated. From this center the orifice diameter was measured as indicated and the orifice center was then determined relative to the plate outside diameter. The uncertainty in the outside diameter measurement is estimated to be 0.03mm therefore the uncertainty in the concentricity is also 0.03mm. No concentricity measurements were made on the plates of the FE5/6 B group. These measurements will be made at a later date by NBS-Washington.

The surface finish was measured across and with the visible finishing marks and are identified as "across" and "with" respectively. Plate flatness was checked with a straight edge and a feeler gauge. The straight edge was laid across the upstream face at 45° intervals. At each position the inspector attempted to slip a .025mm feeler gauge between the plate and the straight edge. If the gauge went between the straight edge and the plate the deviation from .025mm was noted as plate flatness, otherwise it was listed as "O.K.". The "orifice edge" was inspected by making a mold of the edge at one place and viewing a cross-section of this mold at 100 times magnification. This permitted determining if the apparent radius of the "sharp" edge was greater than 0.025mm. If the radius was larger or included burrs, it was noted, otherwise it was listed as "O.K.". General inspection of the plates were made to note nicks at the edge or in the upstream face within the pipe diameter. If nicks were visible, they were noted under comments. Position of the blemishes are in degrees clockwise from the handle viewed from the inlet side of the plate. For 24 hours prior to measurement, all of the plates were placed in a room which was controlled at 293.15K + 0.1K. The orifice plates were all beveled on the downstream side with a 45° bevel. The following figure shows how the bevel was measured and where the edge thickness "e" was measured.

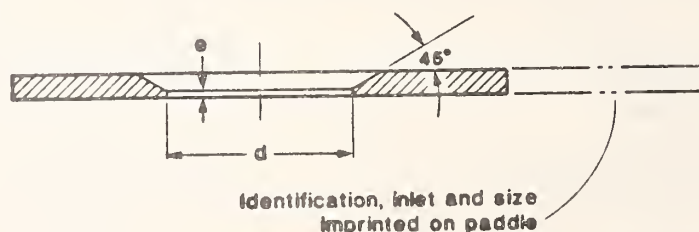

The orifice plates were all identified using a system comparable to that used for the orifice meter runs. The two leading letters FE were followed by two numbers separated with a slash. These numbers specified the meter runs that accommodate this plate. Following these numbers was a dash and a number and a letter A or B. The number was unique for the orifice hole and the letter A or B specified the plate set. An example would be FE5/6-2A which is a plate for the four inch meter runs and is the 1-1/2 inch nominal orifice from the A set. The identification and the nominal size are stamped on the inlet side of the handle of the orifice plate along with the notation "INLET".



ORIFICE PLATE MEASUREMENTS

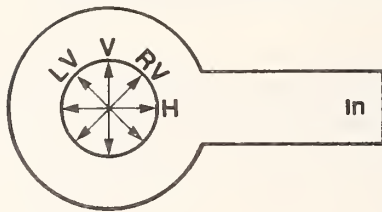

PLATE NUMBER FE 1/2 4A

Edge Thickness, "e" (cm(in )) 0.0724(0.0285)

Plate Flatness OK

Plate Finish ( $\mu(\mu\text{in})$ )

Across 0.70 (27.56)

With 0.25 (9.84)

Orifice Edge OK

Plate Thickness (cm(in )) 0.315 (0.124)

Outside Diameter (cm(in )) 11.107 (4.373)

Concentricity of hole to OD (cm(in )) 0.008(0.003)

Comments \_\_\_\_\_

V (cm(in )) 2.8555(1.1242)

LV (cm(in )) 2.8562(1.1245)

RV (cm(in )) 2.8555(1.1242)

H (cm(in )) 2.8552(1.1241)

AVG (cm(in )) 2.8555(1.1242)

PLATE NUMBER FE 1/2 5A

Edge Thickness, "e" (cm(in )) 0.071 (0.028)

Plate Flatness OK

Plate Finish ( $\mu(\mu\text{in})$ )

Across 0.35 (13.78)

With 0.20 (7.87)

Orifice Edge OK

Plate Thickness (cm(in )) 0.3111 (0.1225)

Outside Diameter (cm(in )) 11.107(4.373)

Concentricity of hole to OD (cm(in )) 0.005 (0.002)

Comments \_\_\_\_\_

V (cm(in )) 3.4917(1.3747)

LV (cm(in )) 3.4928(1.3751)

RV (cm(in )) 3.4915(1.3746)

H (cm(in )) 3.4912(1.3745)

AVG (cm(in )) 3.4917(1.3747)

PLATE NUMBER FE 1/2 6A

Edge Thickness, "e" (cm(in )) 0.075(0.030)

Plate Flatness OK

Plate Finish ( $\mu(\mu\text{in})$ )

Across 0.25 (9.84)

With 0.40 (15.75)

Orifice Edge OK

Plate Thickness (cm(in )) 0.310 (0.122)

Outside Diameter (cm(in )) 11.105 (4.372)

Concentricity of hole to OD (cm(in )) 0.010(0.004)

Comments \_\_\_\_\_

V (cm(in )) 3.8108(1.5003)

LV (cm(in )) 3.8113(1.5005)

RV (cm(in )) 3.8105(1.5002)

H (cm(in )) 3.8108(1.5003)

AVG (cm(in )) 3.8108(1.5003)

ORIFICE PLATE MEASUREMENTS

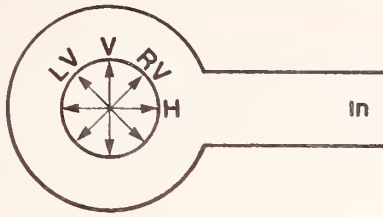

PLATE NUMBER FE 1/2 1B

Edge Thickness, "e" (cm(in )) 0.0724(0.0285)

Plate Flatness OK

Plate Finish ( $\mu$ ( $\mu$ in ))

Across 0.20 (7.87)

With 0.25 (9.84)

Orifice Edge OK

Plate Thickness (cm(in )) 0.302 (0.119)

Outside Diameter (cm(in )) 11.100(4.370)

Concentricity of hole to OD (cm(in )) +0.025 (0.010)

Comments \_\_\_\_\_

V (cm(in )) 1.2675(0.4990)  
 LV (cm(in )) 1.2738(0.5015)  
 RV (cm(in )) 1.2710(0.5004)  
 H (cm(in )) 1.2659(0.4984)  
 AVG (cm(in )) 1.2695(0.4998)

PLATE NUMBER FE 1/2 2B

Edge Thickness, "e" (cm(in )) 0.0699(0.0275)

Plate Flatness OK

Plate Finish ( $\mu$ ( $\mu$ in ))

Across 0.25 (9.84)

With 0.20 (7.87)

Orifice Edge OK

Plate Thickness (cm(in )) 0.3111 (0.1225)

Outside Diameter (cm(in )) 11.105 (4.372)

Concentricity of hole to OD (cm(in )) +0.005 (0.002)

Comments \_\_\_\_\_

V (cm(in )) 1.9040(0.7496)  
 LV (cm(in )) 1.9047(0.7499)  
 RV (cm(in )) 1.9045(0.7498)  
 H (cm(in )) 1.9045(0.7498)  
 AVG (cm(in )) 1.9045(0.7498)

PLATE NUMBER FE 1/2 3B

Edge Thickness, "e" (cm(in )) 0.0724(0.0285)

Plate Flatness OK

Plate Finish ( $\mu$ ( $\mu$ in ))

Across 0.25 (9.84)

With 0.25 (9.84)

Orifice Edge OK

Plate Thickness (cm(in )) 0.315 (0.124)

Outside Diameter (cm(in )) 11.105 (4.372)

Concentricity of hole to OD (cm(in )) +0.005(0.002)

Comments \_\_\_\_\_

V (cm(in )) 2.5390(0.9996)  
 LV (cm(in )) 2.5392(0.9997)  
 RV (cm(in )) 2.5395(0.9998)  
 H (cm(in )) 2.5397(0.9995)  
 AVG (cm(in )) 2.5390(0.9996)

ORIFICE PLATE MEASUREMENTS

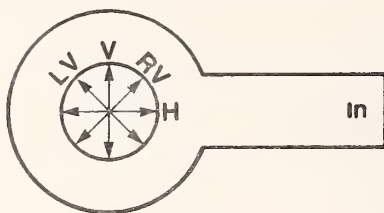

PLATE NUMBER FE 1/2 4B

Edge Thickness, "e" (cm(in )) 0.0737(0.0290)

Plate Flatness OK

Plate Finish ( $\mu(\mu\text{in})$ )

Across 0.25 (9.84)

With 0.20 (7.87)

Orifice Edge OK

Plate Thickness (cm(in )) 0.3137 (0.1235)

Outside Diameter (cm(in )) 11.107 (4.373)

Concentricity of hole to OD (cm(in ))  $\pm 0.005$  (0.002)

Comments \_\_\_\_\_

V (cm(in )) 2.8567(1.1247)

LV (cm(in )) 2.8570(1.1248)

RV (cm(in )) 2.8560(1.1244)

H (cm(in )) 2.8560(1.1244)

AVG (cm(in )) 2.8565(1.1246)

PLATE NUMBER FE 1/2 5B

Edge Thickness, "e" (cm(in )) 0.0851 (0.0335)

Plate Flatness OK

Plate Finish ( $\mu(\mu\text{in})$ )

Across 0.25 (9.84)

With 0.35 (13.78)

Orifice Edge OK

Plate Thickness (cm(in )) 0.3162 (0.1245)

Outside Diameter (cm(in )) 11.110 (4.374)

Concentricity of hole to OD (cm(in ))  $\pm 0.005$  (0.002)

Comments \_\_\_\_\_

V (cm(in )) 3.4917(1.3747)

LV (cm(in )) 3.4922(1.3749)

RV (cm(in )) 3.4912(1.3745)

H (cm(in )) 3.4910(1.3744)

AVG (cm(in )) 3.4915(1.3746)

PLATE NUMBER FE 1/2 6B

Edge Thickness, "e" (cm(in )) 0.0711(0.0280)

Plate Flatness OK

Plate Finish ( $\mu(\mu\text{in})$ )

Across 0.35 (13.78)

With 0.20 (7.87)

Orifice Edge OK

Plate Thickness (cm(in )) 0.312 (0.123)

Outside Diameter (cm(in )) 11.107 (4.373)

Concentricity of hole to OD (cm(in ))  $\pm 0.005$  (0.002)

Comments \_\_\_\_\_

V (cm(in )) 3.8103(1.5001)

LV (cm(in )) 3.8115(1.5006)

RV (cm(in )) 3.8100(1.5000)

H (cm(in )) 3.8105(1.5002)

AVG (cm(in )) 3.8105(1.5002)

ORIFICE PLATE MEASUREMENTS

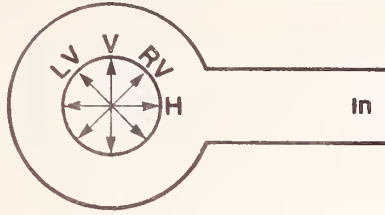

PLATE NUMBER FE 3/4 1A

Edge Thickness, "e" (cm(in )) 0.0635(0.0250)

Plate Flatness high 0.005 cm

Plate Finish ( $\mu(\mu\text{in})$ )

Across 0.35 (13.78)

With 0.25 (9.84)

Orifice Edge OK

Plate Thickness (cm(in )) 0.3188(0.1255)

Outside Diameter (cm(in )) 14.796 (5.825)

Concentricity of hole to OD (cm(in )) 0.008(0.003)

Comments \_\_\_\_\_

V (cm(in )) 1.5867(0.6247)

LV (cm(in )) 1.5872(0.6249)

RV (cm(in )) 1.5880(0.6252)

H (cm(in )) 1.5875(0.6250)

AVG (cm(in )) 1.5872(0.6249)

PLATE NUMBER FE 3/4 2A

Edge Thickness, "e" (cm(in )) 0.0549(0.0216)

Plate Flatness low 0.010 cm

Plate Finish ( $\mu(\mu\text{in})$ )

Across 0.35 (13.78)

With 0.25 (9.84)

Orifice Edge OK

Plate Thickness (cm(in )) 0.295 -0.302(0.116-0.119)

Outside Diameter (cm(in )) 14.9108 (5.8704)

Concentricity of hole to OD (cm(in )) 0.008(0.003)

Comments \_\_\_\_\_

V (cm(in )) 2.8567(1.1247)

LV (cm(in )) 2.8575(1.1250)

RV (cm(in )) 2.8580(1.1252)

H (cm(in )) 2.8582(1.1253)

AVG (cm(in )) 2.8575(1.1250)

PLATE NUMBER FE 3/4 3A

Edge Thickness, "e" (cm(in )) 0.0737(0.0290)

Plate Flatness low 0.010 cm

Plate Finish ( $\mu(\mu\text{in})$ )

Across 0.35 (13.78)

With 0.20 (7.87)

Orifice Edge OK

Plate Thickness (cm(in )) 0.3175(0.1250)

Outside Diameter (cm(in )) 14.9136(5.867)

Concentricity of hole to OD (cm(in )) 0.005(0.002)

Comments \_\_\_\_\_

V (cm(in )) 3.8097(1.4999)

LV (cm(in )) 3.8103(1.5001)

RV (cm(in )) 3.8097(1.4999)

H (cm(in )) 3.8103(1.5001)

AVG (cm(in )) 3.8100(1.5000)

ORIFICE PLATE MEASUREMENTS

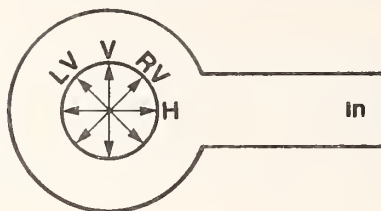

PLATE NUMBER FE 3/4 4A

Edge Thickness, "e" (cm(in ))	<u>0.053(0.021)</u>	V (cm(in ))	<u>4.4458(1.7503)</u>
Plate Flatness	OK	LV (cm(in ))	<u>4.4453(1.7501)</u>
Plate Finish ( $\mu(\mu\text{in})$ )		RV (cm(in ))	<u>4.4463(1.7505)</u>
Across	<u>0.30 (11.81)</u>	H (cm(in ))	<u>4.4460(1.7504)</u>
With	<u>0.25 (9.84)</u>	AVG (cm(in ))	<u>4.4458(1.7503)</u>
Orifice Edge	OK		
Plate Thickness (cm(in ))	<u>0.315 (0.124)</u>		
Outside Diameter (cm(in ))	<u>14.902 (5.867)</u>		
Concentricity of hole to OD (cm(in ))	<u><math>\pm 0.005(0.002)</math></u>		
Comments	_____		

PLATE NUMBER FE 3/4 5A

Edge Thickness, "e" (cm(in ))	<u>0.0673(0.0265)</u>	V (cm(in ))	<u>5.0813(2.0005)</u>
Plate Flatness	OK	LV (cm(in ))	<u>5.0818(2.0007)</u>
Plate Finish ( $\mu(\mu\text{in})$ )		RV (cm(in ))	<u>5.0810(2.0004)</u>
Across	<u>0.35 (13.78)</u>	H (cm(in ))	<u>5.0805(2.0002)</u>
With	<u>0.25 (9.84)</u>	AVG (cm(in ))	<u>5.0815(2.0006)</u>
Orifice Edge	<u>nick 45°</u>		
Plate Thickness (cm(in ))	<u>0.3188 (0.1255)</u>		
Outside Diameter (cm(in ))	<u>14.9301 (5.8780)</u>		
Concentricity of hole to OD (cm(in ))	<u><math>\pm 0.005(0.002)</math></u>		
Comments	_____		

PLATE NUMBER FE 3/4 6A

Edge Thickness, "e" (cm(in ))	<u>0.0668 (0.0263)</u>	V (cm(in ))	<u>5.7127(2.2491)</u>
Plate Flatness	OK	LV (cm(in ))	<u>5.7130(2.2492)</u>
Plate Finish ( $\mu(\mu\text{in})$ )		RV (cm(in ))	<u>5.7132(2.2493)</u>
Across	<u>0.39 (15.35)</u>	H (cm(in ))	<u>5.7132(2.2493)</u>
With	<u>0.21 (8.27)</u>	AVG (cm(in ))	<u>5.7130(2.2492)</u>
Orifice Edge	OK		
Plate Thickness (cm(in ))	<u>0.3150 (0.1240)</u>		
Outside Diameter (cm(in ))	<u>14.9187 (5.8735)</u>		
Concentricity of hole to OD (cm(in ))	<u><math>\pm 0.005(0.002)</math></u>		
Comments	_____		



ORIFICE PLATE MEASUREMENTS

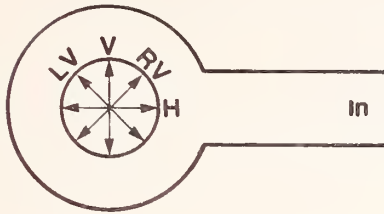

PLATE NUMBER FE 3/4 1B

Edge Thickness, "e" (cm(in )) 0.0597(0.0235)

Plate Flatness OK

Plate Finish ( $\mu$ ( $\mu$ in ))

Across 0.5 (19.7)

With 0.25 (9.8)

Orifice Edge nick @ 90°

Plate Thickness (cm(in )) 0.3183(0.1253)

Outside Diameter (cm(in )) 14.9225(5.8750)

Concentricity of hole to OD (cm(in )) ±0.010 (0.004)

Comments \_\_\_\_\_

V (cm(in )) 1.5870(0.6248)

LV (cm(in )) 1.5875(0.6250)

RV (cm(in )) 1.5872(0.6249)

H (cm(in )) 1.5865(0.6246)

AVG (cm(in )) 1.5870(0.6248)

PLATE NUMBER FE 3/4 2B

Edge Thickness, "e" (cm(in )) 0.0686 (0.027)

Plate Flatness OK

Plate Finish ( $\mu$ ( $\mu$ in ))

Across 0.35 (13.8)

With 0.25 (9.8)

Orifice Edge OK

Plate Thickness (cm(in )) 0.3183 (0.1253)

Outside Diameter (cm(in )) 14.9174 (5.8730)

Concentricity of hole to OD (cm(in )) ±0.005 (0.002)

Comments \_\_\_\_\_

V (cm(in )) 2.8578(1.1251)

LV (cm(in )) 2.8578(1.1251)

RV (cm(in )) 2.8570(1.1248)

H (cm(in )) 2.8567(1.1247)

AVG (cm(in )) 2.8572(1.1249)

PLATE NUMBER FE 3/4 3B

Edge Thickness, "e" (cm(in )) 0.0724 (0.0285)

Plate Flatness OK

Plate Finish ( $\mu$ ( $\mu$ in ))

Across 0.35 (13.78)

With 0.20 (7.87)

Orifice Edge nick @ 315°

Plate Thickness (cm(in )) 0.3114 (0.1226)

Outside Diameter (cm(in )) 14.9177 (5.8731)

Concentricity of hole to OD (cm(in )) ±0.005 (0.002)

Comments \_\_\_\_\_

V (cm(in )) 3.8090(1.4996)

LV (cm(in )) 3.8097(1.4999)

RV (cm(in )) 3.8095(1.4998)

H (cm(in )) 3.8090(1.4996)

AVG (cm(in )) 3.8092(1.4997)

ORIFICE PLATE MEASUREMENTS

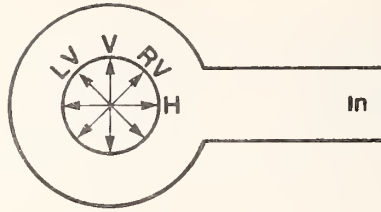

PLATE NUMBER	FE 3/4 4B	
Edge Thickness, "e" (cm(in ))	<u>0.074 (0.029)</u>	V (cm(in )) <u>4.4445(1.7498)</u>
Plate Flatness H=0.K. V=0.0038 cm		LV (cm(in )) <u>4.4450(1.7500)</u>
Plate Finish ( $\mu$ ( $\mu$ in ))		RV (cm(in )) <u>4.4450(1.7500)</u>
Across 0.35 (13.78)		H (cm(in )) <u>4.4437(1.7495)</u>
With 0.225 (8.86)		AVG (cm(in )) <u>4.4445(1.7498)</u>
Orifice Edge	OK	
Plate Thickness (cm(in ))	<u>0.3175 (0.1250)</u>	
Outside Diameter (cm(in ))	<u>14.920 (5.874)</u>	
Concentricity of hole to OD (cm(in ))	<u>0.005 (0.002)</u>	
Comments	_____	

PLATE NUMBER	FE 3/4 5B	
Edge Thickness, "e" (cm(in ))	<u>0.0716(0.0282)</u>	V (cm(in )) <u>5.0795(1.9998)</u>
Plate Flatness	OK	LV (cm(in )) <u>5.0797(1.9999)</u>
Plate Finish ( $\mu$ ( $\mu$ in ))		RV (cm(in )) <u>5.0795(1.9998)</u>
Across 0.30 (11.81)		H (cm(in )) <u>5.0790(1.9996)</u>
With 0.17 (6.69)		AVG (cm(in )) <u>5.0795(1.9998)</u>
Orifice Edge	OK	
Plate Thickness (cm(in ))	<u>0.3162 (0.1245)</u>	
Outside Diameter (cm(in ))	<u>14.9149 (5.8720)</u>	
Concentricity of hole to OD (cm(in ))	<u><math>\pm</math>0.005 (0.002)</u>	
Comments	_____	

PLATE NUMBER	FE 3/4 6B	
Edge Thickness, "e" (cm(in ))	<u>0.0714 (0.0281)</u>	V (cm(in )) <u>5.7142(2.2497)</u>
Plate Flatness	OK	LV (cm(in )) <u>5.7142(2.2497)</u>
Plate Finish ( $\mu$ ( $\mu$ in ))		RV (cm(in )) <u>5.7137(2.2495)</u>
Across 0.38 (14.96)		H (cm(in )) <u>5.7137(2.2495)</u>
With 0.21 (8.27)		AVG (cm(in )) <u>5.7140(2.2496)</u>
Orifice Edge	OK	
Plate Thickness (cm(in ))	<u>0.3099 (0.1220)</u>	
Outside Diameter (cm(in ))	<u>14.916 (5.8725)</u>	
Concentricity of hole to OD (cm(in ))	<u><math>\pm</math>0.008 (0.003)</u>	
Comments	_____	



ORIFICE PLATE MEASUREMENTS

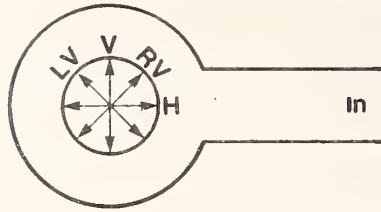

PLATE NUMBER	FE 5/6 4A	
Edge Thickness, "e" (cm(in ))	<u>0.1478(0.0582)</u>	V (cm(in )) <u>5.7127(2.2491)</u>
Plate Flatness	OK	LV (cm(in )) <u>5.7120(2.2488)</u>
Plate Finish ( $\mu$ ( $\mu$ in ))		RV (cm(in )) <u>5.7142(2.2497)</u>
Across	<u>0.30 (11.81)</u>	H (cm(in )) <u>5.7120(2.2488)</u>
With	<u>0.28 (10.83)</u>	AVG (cm(in )) <u>5.7127(2.2491)</u>
Orifice Edge	OK	
Plate Thickness (cm(in ))	<u>0.3094 (0.1218)</u>	
Outside Diameter (cm(in ))	<u>18.095 (7.124)</u>	
Concentricity of hole to OD (cm(in ))	<u><math>\pm 0.023(0.009)</math></u>	
Comments	_____	

PLATE NUMBER	FE 5/6 5A	
Edge Thickness, "e" (cm(in ))	<u>0.1382(0.0544)</u>	V (cm(in )) <u>6.6652(2.6241)</u>
Plate Flatness	OK	LV (cm(in )) <u>6.6662(2.6245)</u>
Plate Finish ( $\mu$ ( $\mu$ in ))		RV (cm(in )) <u>6.6657(2.6243)</u>
Across	<u>0.30 (11.81)</u>	H (cm(in )) <u>6.6667(2.6247)</u>
With	<u>0.23 (8.86)</u>	AVG (cm(in )) <u>6.6660(2.6244)</u>
Orifice Edge	OK	
Plate Thickness (cm(in ))	<u>0.305 (0.120)</u>	
Outside Diameter (cm(in ))	<u>18.087 (7.121)</u>	
Concentricity of hole to OD (cm(in ))	<u><math>\pm 0.003(0.001)</math></u>	
Comments	_____	

PLATE NUMBER	FE 5/6 6A	
Edge Thickness, "e" (cm(in ))	<u>0.1341(0.0528)</u>	V (cm(in )) <u>7.6200(3.0000)</u>
Plate Flatness	OK	LV (cm(in )) <u>7.6205(3.0003)</u>
Plate Finish ( $\mu$ ( $\mu$ in ))		RV (cm(in )) <u>7.6200(3.0000)</u>
Across	<u>0.35 (13.78)</u>	H (cm(in )) <u>7.6210(3.0004)</u>
With	<u>0.25 (9.84)</u>	AVG (cm(in )) <u>7.6202(3.0001)</u>
Orifice Edge	OK	
Plate Thickness (cm(in ))	<u>0.3061(0.1205)</u>	
Outside Diameter (cm(in ))	<u>18.092(7.123)</u>	
Concentricity of hole to OD (cm(in ))	<u><math>\pm 0.023(0.009)</math></u>	
Comments	_____	

ORIFICE PLATE MEASUREMENTS

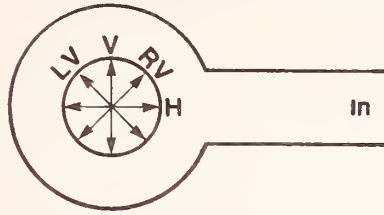

PLATE NUMBER	FE 5/6 1B	
Edge Thickness, "e" (cm(in ))	0.132(0.052)	V (cm(in )) 2.2230(0.8752)
Plate Flatness	OK	LV (cm(in )) 2.2230(0.8752)
Plate Finish ( $\mu(\mu\text{in})$ )		RV (cm(in )) 2.2230(0.8752)
Across	0.53 (20.87)	H (cm(in )) 2.2230(0.8752)
With	0.44 (17.32)	AVG (cm(in )) 2.2230(0.8752)
Orifice Edge	GOOD	
Plate Thickness (cm(in ))	0.305 (0.120)	
Outside Diameter (cm(in ))	18.0914 (7.1226)	
Concentricity of hole to OD (cm(in ))		
Comments	_____	

PLATE NUMBER	FE 5/6 2B	
Edge Thickness, "e" (cm(in ))	0.127(0.050)	V (cm(in )) 3.8080(1.4992)
Plate Flatness	OK	LV (cm(in )) 3.8100(1.5000)
Plate Finish ( $\mu(\mu\text{in})$ )		RV (cm(in )) 3.8100(1.5000)
Across	0.30 (11.81)	H (cm(in )) 3.8082(1.4993)
With	0.25 (9.84)	AVG (cm(in )) 3.8090(1.4996)
Orifice Edge	nicks 0°; 180°	
Plate Thickness (cm(in ))	0.305 (0.120)	
Outside Diameter (cm(in ))	18.0952(7.1241)	
Concentricity of hole to OD (cm(in ))		
Comments	_____	

PLATE NUMBER	FE 5/6 3B	
Edge Thickness, "e" (cm(in ))	0.145(0.057)	V (cm(in )) 5.0785(1.9994)
Plate Flatness	OK	LV (cm(in )) 5.0775(1.9990)
Plate Finish ( $\mu(\mu\text{in})$ )		RV (cm(in )) 5.0777(1.9991)
Across	0.29 (11.42)	H (cm(in )) 5.0785(1.9994)
With	0.10 (3.94)	AVG (cm(in )) 5.0780(1.9992)
Orifice Edge	GOOD	
Plate Thickness (cm(in ))	0.307 (0.121)	
Outside Diameter (cm(in ))	18.0889(7.1216)	
Concentricity of hole to OD (cm(in ))		
Comments	_____	



ORIFICE PLATE MEASUREMENTS

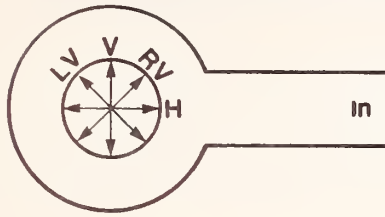

PLATE NUMBER	FE 7/8 1A	
Edge Thickness, "e" (cm(in ))	0.1207(0.0475)	V (cm(in )) 3.1717(1.2487)
Plate Flatness	LOW 0.020	LV (cm(in )) 3.1732(1.2493)
Plate Finish ( $\mu(\mu\text{in})$ )		RV (cm(in )) 3.1725(1.2490)
Across	0.45 (17.72)	H (cm(in )) 3.1725(1.2490)
With	0.40 (15.75)	AVG (cm(in )) 3.1725(1.2490)
Orifice Edge	OK	
Plate Thickness (cm(in ))	0.297 (0.117)	
Outside Diameter (cm(in ))	25.065(9.868)	
Concentricity of hole to OD (cm(in ))	$\pm 0.025(0.010)$	
Comments	Concave by 0.020	

---

PLATE NUMBER	FE 7/8 2A	
Edge Thickness, "e" (cm(in ))	0.142 (0.056)	V (cm(in )) 5.7140(2.2496)
Plate Flatness	OK	LV (cm(in )) 5.7150(2.2500)
Plate Finish ( $\mu(\mu\text{in})$ )		RV (cm(in )) 5.7153(2.2501)
Across	0.43 (16.73)	H (cm(in )) 5.7145(2.2498)
With	0.30 (11.81)	AVG (cm(in )) 5.7147(2.2499)
Orifice Edge	OK	
Plate Thickness (cm(in ))	0.297 (0.117)	
Outside Diameter (cm(in ))	25.067(9.869)	
Concentricity of hole to OD (cm(in ))	$\pm 0.028(0.011)$	
Comments		

---

PLATE NUMBER	FE 7/8 3A	
Edge Thickness, "e" (cm(in ))	0.137(0.054)	V (cm(in )) 7.6210(3.0004)
Plate Flatness	OK	LV (cm(in )) 7.6210(3.0004)
Plate Finish ( $\mu(\mu\text{in})$ )		RV (cm(in )) 7.6210(3.0004)
Across	0.45 (17.72)	H (cm(in )) 7.6205(3.0002)
With	0.30 (11.81)	AVG (cm(in )) 7.6208(3.0003)
Orifice Edge		
Plate Thickness (cm(in ))	0.297 (0.117)	
Outside Diameter (cm(in ))	25.067 (9.869)	
Concentricity of hole to OD (cm(in ))	$\pm 0.028(0.011)$	
Comments		

---

ORIFICE PLATE MEASUREMENTS

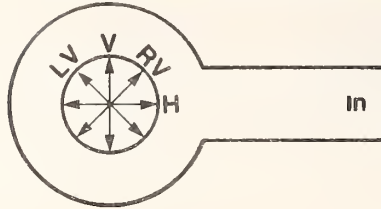

PLATE NUMBER	FE 7/8 4A	
Edge Thickness, "e" (cm(in ))	<u>0.130 (0.051)</u>	V (cm(in )) <u>8.8885(3.4994)</u>
Plate Flatness	OK	LV (cm(in )) <u>8.8882(3.4993)</u>
Plate Finish ( $\mu$ ( $\mu$ in ))		RV (cm(in )) <u>8.8892(3.4997)</u>
Across	<u>0.55 (21.65)</u>	H (cm(in )) <u>8.8885(3.4994)</u>
With	<u>0.40 (15.75)</u>	AVG (cm(in )) <u>8.8885(3.4994)</u>
Orifice Edge	OK	
Plate Thickness (cm(in ))	<u>0.300 (0.118)</u>	
Outside Diameter (cm(in ))	<u>25.067(9.869)</u>	
Concentricity of hole to OD (cm(in ))	<u><math>\pm 0.025(0.010)</math></u>	
Comments	<u>small nick @90° and various places on both sides</u>	

PLATE NUMBER	FE 7/8 5A	
Edge Thickness, "e" (cm(in ))	<u>0.122(0.048)</u>	V (cm(in )) <u>10.1597(3.9999)</u>
Plate Flatness	OK	LV (cm(in )) <u>10.1595(3.9998)</u>
Plate Finish ( $\mu$ ( $\mu$ in ))		RV (cm(in )) <u>10.1605(4.0002)</u>
Across	<u>0.425 (16.73)</u>	H (cm(in )) <u>10.1595(3.9998)</u>
With	<u>0.325 (12.80)</u>	AVG (cm(in )) <u>10.1597(3.9999)</u>
Orifice Edge	OK	
Plate Thickness (cm(in ))	<u>0.292 (0.115)</u>	
Outside Diameter (cm(in ))	<u>25.067 (9.869)</u>	
Concentricity of hole to OD (cm(in ))	<u><math>\pm 0.028(0.011)</math></u>	
Comments		

PLATE NUMBER	FE 7/8 6A	
Edge Thickness, "e" (cm(in ))	<u>0.132(0.052)</u>	V (cm(in )) <u>11.4275(4.4990)</u>
Plate Flatness	OK	LV (cm(in )) <u>11.4280(4.4992)</u>
Plate Finish ( $\mu$ ( $\mu$ in ))		RV (cm(in )) <u>11.4297(4.4999)</u>
Across	<u>0.40 (15.75)</u>	H (cm(in )) <u>11.4277(4.4991)</u>
With	<u>0.30 (11.81)</u>	AVG (cm(in )) <u>11.4282(4.4993)</u>
Orifice Edge	OK	
Plate Thickness (cm(in ))	<u>0.2984 (0.1175)</u>	
Outside Diameter (cm(in ))	<u>25.067 (9.869)</u>	
Concentricity of hole to OD (cm(in ))	<u><math>\pm 0.028(0.011)</math></u>	
Comments		



ORIFICE PLATE MEASUREMENTS

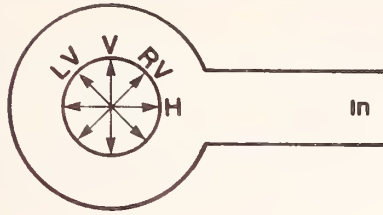

PLATE NUMBER FE 7/8 1B

Edge Thickness, "e" (cm(in ))	<u>1.283(0.505)</u>	V (cm(in ))	<u>3.1727(1.2491)</u>
Plate Flatness	<u>LOW 0.019</u>	LV (cm(in ))	<u>3.1725(1.2490)</u>
Plate Finish ( $\mu(\mu\text{in})$ )		RV (cm(in ))	<u>3.1730(1.2492)</u>
Across	<u>0.45 (17.72)</u>	H (cm(in ))	<u>3.1722(1.2489)</u>
With	<u>0.35 (13.78)</u>	AVG (cm(in ))	<u>3.1727(1.2491)</u>
Orifice Edge	<u>OK</u>		
Plate Thickness (cm(in ))	<u>0.302 (0.119)</u>		
Outside Diameter (cm(in ))	<u>25.070(9.870)</u>		
Concentricity of hole to OD (cm(in ))	<u><math>\pm 0.030(0.012)</math></u>		
Comments	<u>Concave by 0.020 in, nicks on both sides</u>		

---

PLATE NUMBER FE 7/8 2B

Edge Thickness, "e" (cm(in ))	<u>0.127(0.050)</u>	V (cm(in ))	<u>5.7145(2.2498)</u>
Plate Flatness	<u>OK</u>	LV (cm(in ))	<u>5.7158(2.2503)</u>
Plate Finish ( $\mu(\mu\text{in})$ )		RV (cm(in ))	<u>5.7145(2.2498)</u>
Across	<u>0.45 (17.72)</u>	H (cm(in ))	<u>5.7153(2.2501)</u>
With	<u>0.40 (15.75)</u>	AVG (cm(in ))	<u>5.7150(2.2500)</u>
Orifice Edge	<u>OK</u>		
Plate Thickness (cm(in ))	<u>0.297 (0.117)</u>		
Outside Diameter (cm(in ))	<u>25.065(9.868)</u>		
Concentricity of hole to OD (cm(in ))	<u><math>\pm 0.028(0.011)</math></u>		
Comments	<u></u>		

---

PLATE NUMBER FE 7/8 3B

Edge Thickness, "e" (cm(in ))	<u>0.130(0.051)</u>	V (cm(in ))	<u>7.6208(3.0003)</u>
Plate Flatness	<u>OK</u>	LV (cm(in ))	<u>7.6210(3.0004)</u>
Plate Finish ( $\mu(\mu\text{in})$ )		RV (cm(in ))	<u>7.6213(3.0005)</u>
Across	<u>0.40 (15.75)</u>	H (cm(in ))	<u>7.6210(3.0004)</u>
With	<u>0.25 (9.84)</u>	AVG (cm(in ))	<u>7.6210(3.0004)</u>
Orifice Edge	<u>OK</u>		
Plate Thickness (cm(in ))	<u>0.300 (0.118)</u>		
Outside Diameter (cm(in ))	<u>25.067(9.869)</u>		
Concentricity of hole to OD (cm(in ))	<u><math>\pm 0.028(0.011)</math></u>		
Comments	<u>nicks at various places on both sides</u>		

---

ORIFICE PLATE MEASUREMENTS

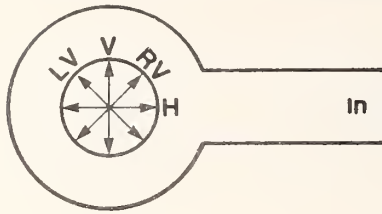

PLATE NUMBER	FE 7/8 4B	
Edge Thickness, "e" (cm(in ))	<u>0.1232(0.0485)</u>	V (cm(in )) <u>8.8882(3.4993)</u>
Plate Flatness	OK	LV (cm(in )) <u>8.8880(3.4992)</u>
Plate Finish ( $\mu$ ( $\mu$ in ))		RV (cm(in )) <u>8.8882(3.4993)</u>
Across	<u>0.50 (19.70)</u>	H (cm(in )) <u>8.8885(3.4994)</u>
With	<u>0.40 (15.75)</u>	AVG (cm(in )) <u>8.8882(3.4993)</u>
Orifice Edge	OK	
Plate Thickness (cm(in ))	<u>0.297 (0.117)</u>	
Outside Diameter (cm(in ))	<u>25.067(9.869)</u>	
Concentricity of hole to OD (cm(in ))	<u><math>\pm 0.025(0.010)</math></u>	
Comments	<u>nicks @ various places on both sides</u>	

---

PLATE NUMBER	FE 7/8 5B	
Edge Thickness, "e" (cm(in ))	<u>0.1333(0.0525)</u>	V (cm(in )) <u>10.1595(3.9998)</u>
Plate Flatness	OK	LV (cm(in )) <u>10.1587(3.9995)</u>
Plate Finish ( $\mu$ ( $\mu$ in ))		RV (cm(in )) <u>10.1600(4.0000)</u>
Across	<u>0.50 (19.70)</u>	H (cm(in )) <u>10.1597(3.9999)</u>
With	<u>0.30 (11.81)</u>	AVG (cm(in )) <u>10.1595(3.9998)</u>
Orifice Edge	OK	
Plate Thickness (cm(in ))	<u>0.2997 (0.118)</u>	
Outside Diameter (cm(in ))	<u>25.070 (9.870)</u>	
Concentricity of hole to OD (cm(in ))	<u><math>\pm 0.030(0.012)</math></u>	
Comments		

---

PLATE NUMBER	FE 7/8 6B	
Edge Thickness, "e" (cm(in ))	<u>0.109(0.043)</u>	V (cm(in )) <u>11.4295(4.4998)</u>
Plate Flatness	OK	LV (cm(in )) <u>11.4285(4.4994)</u>
Plate Finish ( $\mu$ ( $\mu$ in ))		RV (cm(in )) <u>11.4287(4.4995)</u>
Across	<u>0.40 (15.75)</u>	H (cm(in )) <u>11.4280(4.4992)</u>
With	<u>0.25 (9.84)</u>	AVG (cm(in )) <u>11.4287(4.4995)</u>
Orifice Edge	OK	
Plate Thickness (cm(in ))	<u>0.297 (0.117)</u>	
Outside Diameter (cm(in ))	<u>25.067(9.869)</u>	
Concentricity of hole to OD (cm(in ))	<u><math>\pm 0.028.(0.011)</math></u>	
Comments		

---

## APPENDIX III.

### Measurements of Flow Conditioners

The flow conditioners were measured at NBS-Boulder, Colorado. The hole pattern in the three plates of each conditioner was in general the same and the plates were mounted so that the holes of each plate lined up with the other plates. The hole pattern was in rows with the holes of the alternate rows offset. If a support rod lay in the position so as to impose on a hole, the hole was left out. All plates have an odd number of rows and the center hole of the center row was at the center line of the plate. The measurements for position of the rows and the rods were made from the center of this hole.

## Flow Conditioner Measurements

Flow conditioner nominal size 4 inch

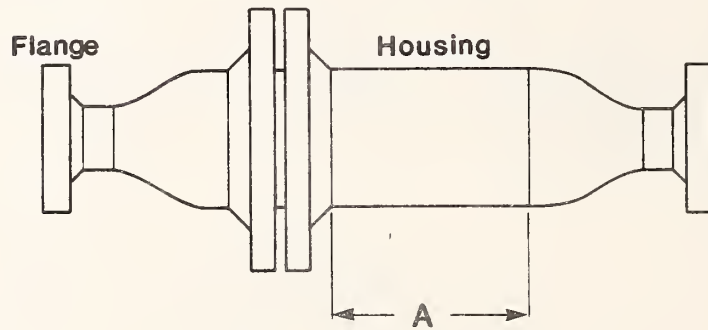

Nominal pipe size section A 4 inch

Inlet and outlet flange 3 inch

Inlet and outlet reducer 3 to 4 inch

Overall length, cm (in) 82.07(32.31)

Straight pipe length, A, cm (in) 20.16(7.94)

600 psi ANSI  
Schedule 40

**Flow Conditioner Nominal Size** 4 inch

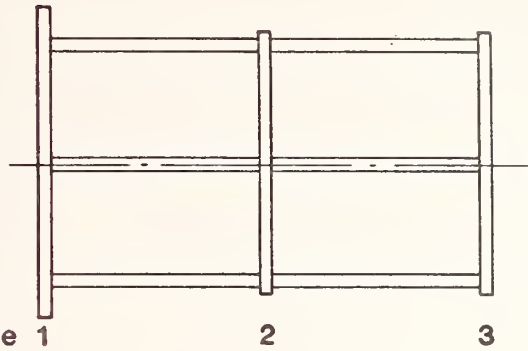
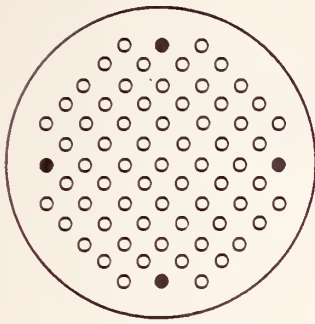

Number of support rods 4 equally spaced

Center line of rod to center line of plates, cm (in) 3.790(1.492)

Rod diameter 1.900(0.748)

Distance between plate 1 and 2 8.776(3.455)

Distance between plate 2 and 3 8.682(3.418)

Diameter, cm (in)

Thickness, cm (in)

Number of holes

Average hole diameter, cm (in)

Average distance between holes, cm (in)

Upstream chamfer

Chamfer depth, cm (in)

Number of rows

Plate 1	Plate 2	Plate 3
17.457 (6.873)	10.160 (4.000)	10.160 (4.000)
0.947 (0.373)	0.960 (0.378)	0.960 (0.378)
53	53	53
0.622 (0.245)	0.617 (0.243)	0.622 (0.245)
0.950 (0.374)	0.947 (0.373)	0.947 (0.373)
90°	90°	90°
0.094 (0.037)	0.091 (0.036)	0.091 (0.036)
11	11	11



## Flow Conditioner Measurements

Flow conditioner nominal size 6 inch

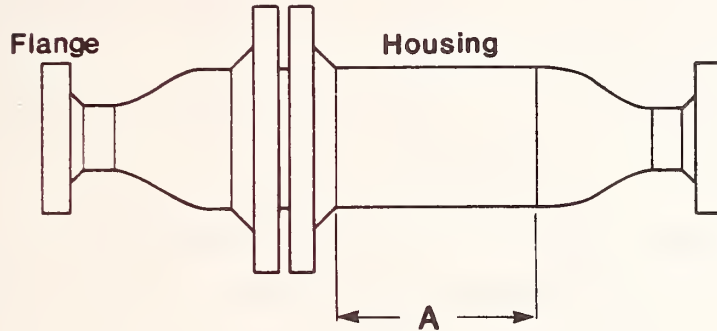

Nominal pipe size section A 6 inch

Inlet and outlet flange 4 inch

Inlet and outlet reducer 4 to 6 inch

Overall length, cm (in) 105.95(41.71)

Straight pipe length, A, cm (in) 30.48(12.00)

600 psi ANSI  
Schedule 40

Flow Conditioner Nominal Size 6 inch

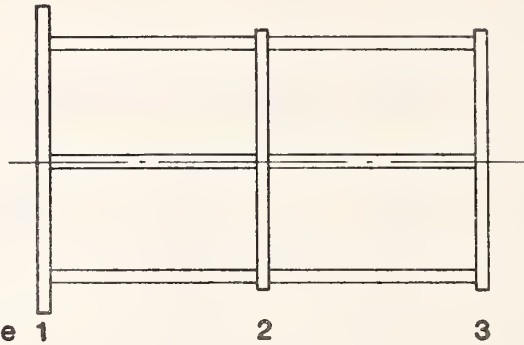
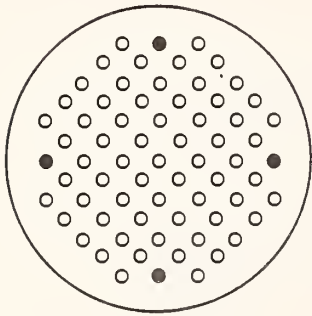

Number of support rods 4 equally spaced

Center line of rod to center line of plates, cm (in) 6.342 (2.497)

Rod diameter 1.905 (0.750)

Distance between plate 1 and 2 14.389 (5.665)

Distance between plate 2 and 3 13.378 (5.267)

Diameter, cm (in)

Thickness, cm (in)

Number of holes

Average hole diameter, cm (in)

Average distance between holes, cm (in)

Upstream chamfer

Chamfer depth, cm (in)

Number of rows

Plate 1	Plate 2	Plate 3
26.662 (10.497)	15.347 (6.042)	15.321 (6.032)
1.016 (0.400)	0.927 (0.365)	0.927 (0.365)
87	87	87
1.041 (0.410)	1.041 (0.410)	1.039 (0.409)
1.364 (0.537)	1.367 (0.538)	1.367 (0.538)
82°	82°	82°
0.152 (0.060)	0.102 (0.040)	0.102 (0.040)
11	11	11





## Flow Conditioner Measurements

Flow conditioner nominal size 10 inch

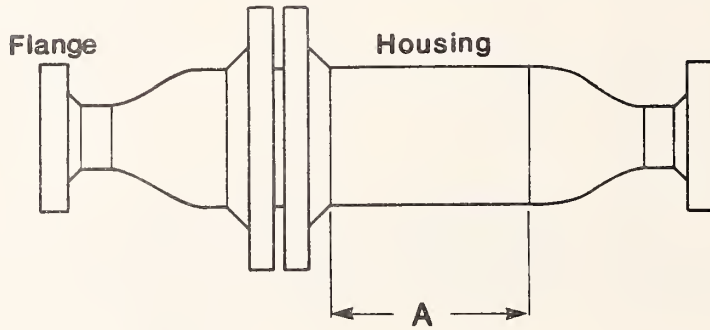

Nominal pipe size section A 10 inch

Inlet and outlet flange 6 inch

Inlet and outlet reducer 6 to 10 inch

Overall length, cm (in) 139.0(54.72)

Straight pipe length, A, cm (in) 47.47(18.69)

600 psi ANSI  
Schedule 40

# Flow Conditioner Nominal Size 10 inch

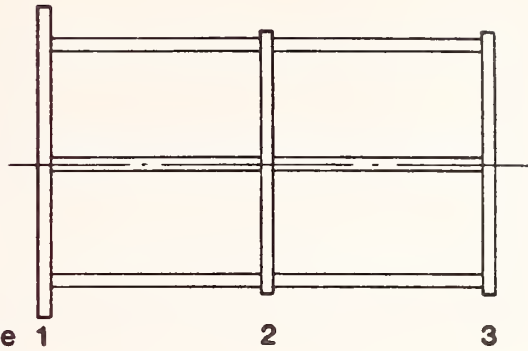
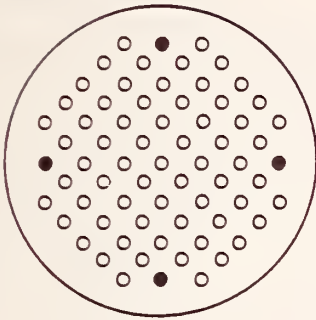

Number of support rods 4 equally spaced

Center line of rod to center line of plates, cm (in) 11.049(4.350)

Rod diameter 1.895 (0.746)

Distance between plate 1 and 2 23.993(9.446)

Distance between plate 2 and 3 23.998(9.448)

Diameter, cm (in)

Thickness, cm (in)

Number of holes

Average hole diameter, cm (in)

Average distance between holes, cm (in)

Upstream chamfer

Chamfer depth, cm (in)

Number of rows

Plate 1	Plate 2	Plate 3
33.973 (13.375)	25.403 (10.001)	25.403 (10.001)
0.960 (0.378)	0.983 (0.387)	0.970 (0.382)
291	291	291
1.036 (0.408)	1.039 (0.409)	1.036 (0.408)
1.346 (0.530)	1.351 (0.532)	1.346 (0.530)
89°	89°	89°
0.157 (0.062)	0.157 (0.062)	0.157 (0.062)
21	21	21

Row Number	Number of Holes	☉ of Rows to ☉ of Plate (cm)	☉ of Plate (in)
1	4	11.902	4.686
2	8	10.716	4.219
3	13	9.530	3.752
4	14	8.341	3.284
5	15	7.135	2.809
6	16	5.954	2.344
7	17	4.747	1.869
8	18	3.576	1.408
9	19	2.367	0.932
10	14	1.171	0.461
11	15	0.020	0.008
12	14	1.207	0.475
13	19	2.405	0.947
14	18	3.579	1.409
15	17	4.773	1.879
16	16	5.969	2.350
17	15	7.150	2.815
18	14	8.362	3.292
19	13	9.530	3.752
20	8	10.721	4.221
21	4	11.885	4.679

U.S. DEPT. OF COMM. <b>BIBLIOGRAPHIC DATA SHEET</b> (See instructions)		1. PUBLICATION OR REPORT NO. NBSIR 83-1685	2. Performing Organ. Report No.	3. Publication Date August 1983
4. TITLE AND SUBTITLE Gas Orifice Meter Discharge Coefficients As Determined by Mass Flow Measurements				
5. AUTHOR(S) D. B. Mann, J.A. Brennan, C.F. Sindt, J.F. LaBrecque, S. McManus, C. Kneebone				
6. PERFORMING ORGANIZATION (If joint or other than NBS, see instructions) NATIONAL BUREAU OF STANDARDS DEPARTMENT OF COMMERCE WASHINGTON, D.C. 20234			7. Contract/Grant No.	8. Type of Report & Period Covered NBSIR
9. SPONSORING ORGANIZATION NAME AND COMPLETE ADDRESS (Street, City, State, ZIP) Gas Research Institute 8600 West Bryn Mawr Avenue Chicago, IL 60631				
10. SUPPLEMENTARY NOTES  <input type="checkbox"/> Document describes a computer program; SF-185, FIPS Software Summary, is attached.				
11. ABSTRACT (A 200-word or less factual summary of most significant information. If document includes a significant bibliography or literature survey, mention it here) Performance data of gas orifice meter runs and plates have been generated under a U.S. gas industry supported program. The data have been developed using nitrogen gas and a unique NBS gas flow measurement facility capable of directly measuring the mass of gas metered by the orifice device. Direct comparison of predictions from empirical equations can now be made at orifice bore Reynolds Numbers near four million. Two meter runs for each of four nominal line sizes and two sets of orifice plates with up to six beta ratios per set were interchanged in order to develop full meter performance characteristics. Orifice meter and flow reference system data are used to calculate discharge and expansion coefficients which in turn are compared to those derived from existing equations. Orifice meter performance data and system descriptions are provided.				
12. KEY WORDS (Six to twelve entries; alphabetical order; capitalize only proper names; and separate key words by semicolons) discharge coefficients; flow measurement; flowmeter; gas flow; mass flow; orifice meter				
13. AVAILABILITY <input checked="" type="checkbox"/> Unlimited <input type="checkbox"/> For Official Distribution. Do Not Release to NTIS <input type="checkbox"/> Order From Superintendent of Documents, U.S. Government Printing Office, Washington, D.C. 20402. <input checked="" type="checkbox"/> Order From National Technical Information Service (NTIS), Springfield, VA. 22161			14. NO. OF PRINTED PAGES 138	
			15. Price \$14.50	





