

NBS

Technical Note

265

TABULATION OF PUBLISHED DATA
ON SOVIET ELECTRON DEVICES
THROUGH JUNE 1965

CHARLES P. MARSDEN



U. S. DEPARTMENT OF COMMERCE
NATIONAL BUREAU OF STANDARDS

THE NATIONAL BUREAU OF STANDARDS

The National Bureau of Standards is a principal focal point in the Federal Government for promoting maximum application of the physical and engineering sciences to the advancement of technology in industry and commerce. Its responsibilities include: development and maintenance of the national standards of measurement, and the provision of means for making measurements consistent with these standards; determination of physical constants and properties of materials; development of methods for testing materials, mechanisms, and structures; and making such tests as may be necessary, particularly for government agencies; cooperation in the establishment of standard practices for incorporation in codes and specifications; advisory service to government agencies on scientific and technical problems; invention and development of devices to serve special needs of the Government; assistance to industry, business, and consumers in the development and acceptance of commercial standards and simplified trade practice recommendations; administration of programs in cooperation with United States business groups and standards organizations for the development of international standards of practice, and maintenance of a clearinghouse for the collection and dissemination of scientific, technical, and engineering information. The scope of the Bureau's activities is suggested in the following listing of its four Institutes and their organizational units:

Institute for Basic Standards. Applied Mathematics, Electricity, Metrology, Mechanics, Heat, Atomic Physics, Physical Chemistry, Laboratory Astrophysics,* Radiation Physics, Radio Standards Laboratory,* Radio Standards Physics, Radio Standards Engineering, Office of Standard Reference Data.

Institute for Materials Research. Analytical Chemistry, Polymers, Metallurgy, Inorganic Materials, Raster Radiations, Cryogenics,* Materials Evaluation Laboratory, Office of Standard Reference Materials.

Institute for Applied Technology. Building Research, Information Technology, Performance Test Development, Electronic Instrumentation, Textile and Apparel Technology Center, Technical Analysis, Office of Weights and Measure, Office of Engineering Standards, Office of Invention and Innovation, Office of Technical Resources, Clearinghouse for Federal Scientific and Technical Information.**

Central Radio Propagation Laboratory.* Ionospheric Telecommunications, Tropospheric Telecommunications, Space Environment Forecasting, Aeronomy.

* Located at Boulder, Colorado 80501

** Located at 3285 Port Royal Road, Springfield, Virginia 22171

NATIONAL BUREAU OF STANDARDS
Technical Note 265

ISSUED OCTOBER 1, 1965

(Supersedes Technical Note 186)

**TABULATION OF PUBLISHED DATA
ON SOVIET ELECTRON DEVICES
THROUGH JUNE 1965**

Charles P. Marsden

NBS Technical Notes are designed to supplement the Bureau's regular publications program. They provide a means for making available scientific data that are of transient or limited interest. Technical Notes may be listed or referred to in the open literature.

For sale by the Superintendent of Documents, Government Printing Office
Washington, D.C., 20402 - Price 50 cents



FOREWORD

This tabulation of published data on Soviet electron devices has been prepared as part of the National Bureau of Standards Electron Devices Data Service. Established in 1948 to provide technical data on radio tubes to members of the Bureau staff, the service has since been extended to other scientists and engineers in government and industry. In the course of the program, a large volume of information on tubes, transistors, diodes, and other electron devices has been accumulated on punched cards. To make this information more readily available, a system has been worked out for automatically tabulating the data in handbook form. Previous tabulations include Tabulation on Data on Microwave Tubes, NBS Handbook 70 (1961); Diode Source Book (published by Semiconductor Products magazine, (1961); and Tabulation of Data on Receiving Tubes, NBS Handbook 83 (1963).

The present tabulation is a revision of Technical Note 186 and is the result of compilation efforts extending over the past six years. All the included information was taken from published specifications, and every effort has been made to ensure accuracy and completeness. However, the Bureau cannot assume responsibility for omissions nor for results obtained with these data.

A. V. Astin, Director.

CONTENTS

	Page
1. Introduction.	1
2. Description of the Tabulation	1
3. Organization of the Tabulation.	2
4. Terminology Used in the Tabulation.	3
5. Groups	
I Numerical Listing	8
II Receiving Tubes	23
III Power Tubes	34
IV Rectifier Tubes	40
V Voltage Regulator Tubes	41
VI Current Regulator Tubes	41
VII Thyratrons.	42
VIII Cathode Ray Tubes	43
IX Microwave Tubes	46
X Transistors	47
XI Diodes - Rectifier.	55
XI-A Diodes - Switching	60
XI-B Diodes - Tunnel.	60
XI-C Diodes - Switch Control.	60
XI-D Diodes - Varactors	60
XII Diodes - Rectifier.	61
XII-A Diodes - Silicon Controlled Rectifiers.	62
XIII Diodes - Regulators	63
XIV Diodes - Mixer and Detector	64
XV Diodes - Photoconductive.	65
XVI Phototubes and Photo multipliers.	66
XVIII Thermocouple Tubes.	68
XIX Thermistors	68
XX Strobotrons	69
XXI Counter Tubes	70
XXII Discharge Tubes	72
XXIII Decatrons	72
XXIV Light Amplifiers.	72
XV Basing Connections.	73

Tabulation of Published Data on Soviet Electron Devices

Charles P. Marsden

This tabulation includes published data on Soviet electron devices as collected from publications, mostly handbooks published by the various ministries and institutes of the USSR. Information is given on all active devices ranging from receiving to microwave devices, semiconductor devices, and miscellaneous devices such as, for example, photographic flash tubes and thermistors.

1. Introduction

The increased circulation of published literature from the USSR and the importation of Soviet equipment has created a need for factual information on Soviet electron devices. To satisfy this need, the National Bureau of Standards Electron Devices Data Service has prepared the present tabulation in a format that could be reproduced directly from punched cards.

This publication is a revision and expansion of Technical Note No. 186 published in June, 1963. The format of several tabulations has been rearranged to include more information and five new semiconductor diode groups have been included. Finally, more than 400 new types have been added.

The sources of the data are the various publications produced in the USSR and include books published by the various ministries, and technical magazines. This information has been intercompared and correlated to eliminate errors and thus assure that this tabulation is as accurate as possible. Because of this intercomparison, references for the data are not given, as data for any one type of device may have been derived from several sources.

2. Description of the Tabulation

In each group the type numbers are arranged in alpha-numerical order in which the first numerical part of the type number is the prime sorting means. Alphabetical prefixes are the secondary sorting means and alphabetical postfixes are the tertiary means. For example in the numerical list, these type numbers will be found in the following order:

V1-0.1/40	SG2S
VT1	TO-2
1A2P	2A1

Alphabetical sorting is performed according to the English alphabet rather than the Russian which was transliterated according to the recommended practice of the Library of Congress as shown below:

A	A	K	K	T	T
Б	B	Л	L	У	U
В	V	М	M	Ф	F
Г	G	Н	N	Х	Kh
Д	D	О	O	Ц	Ts
Е	Ye	П	P	Ш	Sh
Ж	Zh	Р	R	Э	E
И	I	С	S		

This transliteration was necessary to put the information on punched cards and it is believed that it will cause little difficulty in use.

3. Organization of the Tabulation

The tabulation is divided into 24 groups, each with a different format and different columnar headings so that the maximum pertinent data may be included.

Group I is a numerical listing of all type numbers in the complete tabulation and also includes discontinued and obsolete types. All these types are defined by the same three-letter code to indicate the kind and type of tube. Furthermore, under the heading "Group No.", Roman numerals are used to show the group number under which the data for a type will be found. In the last column, the GOST (State National Standard) Specification Number (followed by the year of publication of the specification) is shown for the type number. These specifications include the information in and follow the format of the domestic military specifications.

This group is also an interchangeability list and known similar types are shown. Further, by means of the following symbol code, the manufacturing area and the obsolescence of the type are indicated.

\$ Domestic manufacture
 = European "
 + Russian "
 * Obsolete or inactive

The above definitions of these symbols are pertinent only to their use in Group I. Due to the limitation of available symbols on listing equipment, these same symbols are used in the other groups but are then defined as shown at the end of the definitions under the paragraph entitled "Code" (p. 4).

The other groups have titles describing the particular class of

devices listed therein. As mentioned previously, the individual type numbers are arranged in the same alpha-numerical order.

Under each heading of the group format, the unit of measurement most common for the characteristic is shown. For example under the heading of Maximum Plate Current (I_p), the unit in the heading is mA (milliamperes). However, where the data are in amperes, the value will be tabulated with the number followed by the letter "A", e.g., 15A. All these changes of units are included in the list of alphabetical symbols under code on pages 4 to 7.

A blank in any column indicates that no value was given in the available data.

Group XXIV, "Bases", lists the basing connections for the particular "Base No." of the previous groups by a system compatible with punched cards.

Instead of the usual base diagram or line drawing, the number of each base pin is given in the column under the symbol of the electrode. This system was developed because many of the Soviet types have base connections which do not conform to the standard base designations of the Electronic Industries Association. In those instances where an electrode is connected to more than one base pin, only the lowest numbered pin is shown in the tabulation.

Outline drawings are shown for the semiconductor diodes and transistors.

4. Terminology used in the Tabulation

4.1 Column Headings

The headings used in the various formats are the standard symbols as defined by the Institute of Radio Engineers or descriptive words for the characteristics. They are not further defined due either to the difficulties of translation or lack of definite information.

4.2 Bulb Size

This column heading, which is used in the Receiving, Power, Rectifier, etc. Groups, uses a special code to describe the bulb shape and size. The numerical part of the code indicates the diameter of the glass bulb or metal anode (power tubes) in eighths of an inch according to the American Standard. The alphabetical part of the code is explained on the following page.

PREFIX

POSTFIX

A - Air-cooled anode
 B - Bell-shape
 C - Ceramic construction
 G - Globe-shaped bulb
 F - Flat top of Soviet design
 H - Helix-shaped flash tube
 M - Metal tube
 P - Spiral
 R - Ring-shaped
 S - ST design, i.e., the domed conical shaped glass bulb
 T - Cylindrical shape
 U - U-shape flash tube
 W - Water-cooled anode

B - Button glass stem
 F - Flat press glass stem

For example, a "T3F" would be a cylindrical bulb with a flat press and having a diameter of 3/8 inch.

4.3 Special Symbols

Receiving tubes have postfixed letters with the following meaning:

"V" - Ruggedized tubes with 500 hour life
 "K" - Vibration tested
 "Ye"- 3,000 to 10,000 hour long-life tubes
 "I" - Intended for pulse use

Rectifier Diodes (Group XI) with postfixed letter "P" are available in reverse polarity.

4.4 Code

Due to the limitations of available columns in the punched card, one- to three-letter codes have been liberally developed and used in the tabulation. These have been chosen to be readily understood. The following table lists the definitions of this code for all groups in alphabetical order.

Code			
A	Change of unit to amperes	AHN	Argon-helium-neon gas-filled
AAB	Alpha and Beta radiation	AKN	Argon-krypton gas-filled
ACO	Acorn tube	AL	Aluminum cathode; countertube
AF	Audio frequency Forced air cooling	ALP	Alpha radiation
AHE	Argon-Helium gas-filled	AMK	Aluminum-Magnesium alloy with potassium surface

Code

AN	Natural air cooling	DBA	Double anode beam pentode
AO	Argon-oxygen gas-filled	DEC	Decatron
AR	Argon gas-filled	DET	Detector operation
ARC	Arc rectifier - Mercury pool	DIO	{ Diode With diode, e.g., triode diode
BA	Barium (metal) cathode	DSC	Disc shape
BAG	Beta and gamma radiation	DUO	Double, e.g., double diode with same cathode
BAL	Ballast or current regulator	DWD	{ Duo diode (single cathode) With duodiode, e.g., triode duodiode
BAO	Barium oxide cathode	E	Common emitter operation
BEA	{ Beam pentode With beam pentode, e.g., triode beam pentode	EL	Electrometer tube
BET	Beta radiation	ELM	Electromagnetic focus of deflection
BIS	Bismuth sulphide	ELS	Electrostatic focus or deflection
BL	Blue luminescence	F	Filamentary cathode
C	{ Circular dynode arrangement Common collector operation Cold cathode Continuous wave operation	FE	Iron cathode; counter tube
CAM	Copper-aluminum-magnesium	FLS	Flash tube (photographic)
CDS	Cadmium sulphide	G	Giga (10^9)
CDSE	Cadmium selenide	GAM	Gamma radiation
CN	Converter	GAN	Germanium alloy, n-type
COM	{ Comutator tubes Compensation of temperature thermistors	GAP	Germanium alloy, p-type
CON	{ Control Switch Temperature control	GDN	Germanium diffused junction, n-type
COU	Counter tube	GDP	Germanium diffused junction, p-type
CP	Cap, external in tabulation of bases	GE	Germanium
CS	Cesium photo surface	GEA	Germanium alloy junction
CSB	Cesium antimony photo surface	GEP	Germanium point-contact
CU	Copper cathode; counter tube	GPP	Germanium point-contact, p-type
CYL	Cylindrical shape (Thermistors)	GR	{ Green luminescence Graphite cathode; counter tube

Code

GS	Gas-filled	MX	} Mixer
GSP	Germanium surface-barrier, p-type	MIX	
GTB	Gated beam pentode	MO	Molybdenum cathode
H	{ Heater type cathode Hecto (10^2)	MOD	Modulator
HE		Helium gas-filled	N
HG	Mercury vapor-filled	NA	Neon-argon gas-filled
HH	Mercury-argon-hydrogen gas-filled	NE	Neon gas-filled
HK	Hydrogen-krypton gas-filled	NEH	Neon-helium gas-filled
HY	Hydrogen gas-filled	NI	Nickel cathode
IC	Iconoscope	NK	Neon-krypton gas-filled
ID	Indicator tube	NSP	Nuclear Spectrometry
IF	Intermediate frequency	OD	Double beam oscilloscope
IGN	Ignitron tube	OS	Oscilloscope
IM	Image orthicon	P	Pulse operation
J	Joules	PA	Power amplifier
K	{ Kilo (10^3) Potassium	PB	Purple-blue luminescence
KLY		Klystron	PBS
KX	Krypton-xenon gas-filled	PEN	Pencil tube
L	Linear dynode arrangement	PHC	Photoconductive diode
LAM	Light Amplifier	PHM	Photomultiplier
LD	Lead cathode; counter tube	PHO	Phototube
LIT	Lighthouse	PND	Pentode
LO	Long persistence screen	POW	{ Pentode With pentode e.g., triode, pentode
M	{ Mega (10^6) Milli (10^{-3})	PR	
MAG		Magnetron	PTG
MD	Medium persistence screen	REC	Rectifier
MEA	Temperature measurement	REG	Regulator (voltage)
MG	Magnesium cathode	RD	Red luminescence
		RF	Radio frequency
		ROC	Rocket tube

Code

Sl-S7	Spectral sensitivity of photo surface	TWN	Twin with separate cathodes, e.g., twin triode
S	Max. dimension of cathode ray tube face	TWT	Traveling-wave tube
SM	Secondary emission pentode	U	{ Micro (10 ⁻⁶) U-shaped
SAN	Silicon alloy, n-type	UF	Ultra high frequency
SAP	Silicon alloy, p-type	V	Venetian-blind dynode arrangement
SCC	Scintillation Counters	VC	Vacuum
SDN	Silicon diffused junction, n-type	VB	Violet-blue luminescence
SH	Short persistence screen	VI	Vidicon
SI	Silicon	VID	Video detector
SIA	Silicon alloy junction	VR	Voltage regulator
SIN	Single e.g., single triode	W	{ Change of units to watts Tungsten cathode Water-cooled
SIP	Silicon, point contact	WG	Wave guide coupling
SI4	Silicon, 4-layer rectifier	WH	White luminescence
SM	Secondary emission pentode	X	Smallest dimension-rectangular photocathode
SN	Tin cathode; counter tube	XE	Xenon gas-filled
SQ	Self-quenching type of counter tube	YO	Yellow-orange luminescence
SWI	Switching diode	3C	Three color screen for television
T	Thoriated tungsten cathode	*	The meaning of these symbols
TET	Tetrode	#	indicated in the column heading
THM	Thermocouple tube	/	Less than (before digits)
THY	Thyratron	*	Obsolete type
TMS	Thermistor		
TRD	With triple diode		
TRI	{ Triode With triode e.g., pentode-triode		
TTR	Triode twin		
TUN	Tunnel diode		
TV	Television tube		

GROUP I, NUMERICAL

TYPE NUMBER	KIND	TYPE	TABLE NO.	SIMILAR TYPES	GOST SPEC. NO.
0.24812-18	BAL	SIN	VI		
0.3817-35	BAL	SIN	VI		
0.3865-135	BAL	SIN	VI		
0.425855-12	BAL	SIN	VI		
0.6P2B	PND	SIN	II	CK505Ax	
0.62H6B	PND	SIN	II		
0.85B55-12	BAL	SIN	VI		
FS-AG	PHC		XV		
FS-AO	PHC		XV		
FS-AV	PHC		XV		
FS-DO	PHC		XV		
FS-KG	PHC		XV		
FS-KO	PHC		XV		
FS-KV	PHC		XV		
GR-0.8/1.6	DWD	SIN		GR1-0.25/1.5+	
TG-0.3/0.3	TRI	THY		TG1-0.1/0.3+, 884\$	
VG0251500	DIO	SIN		GR1-0.25/1.5+	
TG-0.5/1.3	TET	THY		TG1-0.1/1.3+, 2050\$	
AS-1	COU		XXI		
D1A	REC		XI		
D1B	REC		XI		
D1D	REC		XI		
D1G	REC		XI		
D1V	REC		XI		
D1YE	REC		XI		
D1ZH	REC		XI		
DG-S1	MIX		XIV		
DG-TS1	REC		XI	D2G+	
DK-11	MIX		XIV		
DK-S1	MIX		XIV		
DK-V1	DET		XIV		
DL-S1	MIX		XIV		
F-1	PHO		XVI		
FD-1	PHC		XV		
FDK-1	PHC		XV		
FEU-1	PHM		XVI		
FEU-1B	PHM		XVI		
FEU-1B1V	PHM		XVI		
FEU-1B2V	PHM		XVI		
FEU-1S	PHM		XVI		
FEU-1V	PHM		XVI		
FS-A1	PHC		XV		
FS-D1	PHC		XV		
FS-K1	PHC		XV		
FT-1	PHC		XV		
FTG-1	PHC		XV		
GE-1	TET	SIN	III	GKE-100*	
GR1-0.25/1.5	DWD	SIN	IV		
GG-1 0.3/8	DIO	SIN	IV		
GG1-0.5/5	DIO	SIN	IV	VG1.5/5000+	
GG-1-0.5/20	DIO	SIN	IV		
GG-1-1/22	DIO	SIN	IV		
GG-1-2/5	DIO	SIN	IV		
GG-1-2/16	DIO	SIN	IV		
GG-1.5/15	DIO	SIN	IV	GG1-0.5/5+	
GK1A	TRI	SIN	III		
GM1A	TRI	SIN	III		
GMI-1B	TRI	SIN	III		
GR1-02/15	DIO	SIN	IV		
GR-1-0.3/8.5	DIO	SIN	IV		
GR-1-25/15	DWD	SIN	IV		
GS-1B	TRI	SIN	III		
GUZH-1	PND	SIN		G411+	
I-1-70/0.8	TRI	IGN	IV		
I-1-100/1.5	TRI	IGN	IV		
I-1-140/0.8	TRI	IGN	IV		
I-1-350/0.8	TRI	IGN	IV		
KF-1	TET	TWN		GU-29+, 829B\$	
KMT-1	TMS		XIX		
KZH1	*PND	SIN		G411*	

GROUP I, NUMERICAL

TYPE NUMBER	KIND	TYPE	TABLE NO.	SIMILAR TYPES	GOST SPEC. NO.
LD1	*TRI	SIN		12S3S+	
LG-1	DWD	SIN		12KH3S+	
L1-1	IC		VIII		
MMT-1	TMS		XIX		
MS1	TRI	SIN		GM-60+	
OG-1	DEC		XXIII		
P1A			X		
P1B			X		
P1D			X		
P1G			X		
P1I			X		
P1V			X		
P1YE			X		
P1ZH			X		
RB-1			XXII		
S1A			X		
S1B			X		
S1D			X		
S1G			X		
S1V			X		
S1YE			X		
SBS-1	COU		XXI		
SG1B	DIO	SIN		OA2\$	
SG1P	DIO	SIN	V	OA2\$	
SG1P-V	REG		V		
SG1P-YE	REG		V		
S1-1BG	COU		XXI		
S1-1G	COU		XXI		
T-1B	TRI	THY		TG-1B+	
TG1B	TRI	THY	VII		
TG1B-V	TRI	THY	VII		
TG1-01/03	TRI	THY	VII	884\$	
TG1-01/13	TET	THY	VII	2050\$	7843-55
TG1-02/05	TET	THY	VII		
TG1-05/12	TRI	THY	VII		
TG1-1.0/0.8	TET	THY	VII		
TG1-1.5/2	TRI	THY	VII		
TG1-1.6/1.3	TRI	THY	VII		
TG1-2.5/3	TRI	THY		TG1-2.5/4**	
TG1-2.5/4	TRI	THY	VII	TG8/3, TG1-2.5/3**	7952-56
TG1-2.5/10	TRI	THY	VII		
TG1-3.2/1.3	TRI	THY	VII		
TG1-5/3	TRI	THY	VII		
TG1-6.4/1.3	TRI	THY	VII		
TG1-12.5/1.3	TRI	THY	VII		
TG1-25/10	TRI	THY			
TG1-125/1	TRI	THY			
TG1-0.1/0.3	TRI	THY			
TG1-1B	TRI	THY	VII		
TG1-1-3/1	TET	THY	VII		
TG1-1-10/1	TRI	THY	VII		
TG1-1-35/3	TRI	THY	VII		
TG1-1-50/5	TRI	THY	VII		
TG1-1-90/8	TRI	THY	VII	MT1-4**	
TG1-1-130/8	TRI	THY	VII		
TG1-1-130/10	TRI	THY	VII		
TG1-1-325/16	TRI	THY	VII	MT1-5+, TG1-325/16+	
TG1-1-400/3.5	TRI	THY	VII		
TG1-1-400/16	TRI	THY	VII		
TG1-1-700/25	TRI	THY	VII		
TKH1	TRI	THY	VII		
TKH1B	TRI	THY	VII		
TM-1	TRI	SIN		655D+, 2C40\$	
TO-1	PND	SIN		102H12S+	
TR1-5/2	TRI	THY	VII	VT-3	7954-56
TR1-6/15	TRI	THY	VII		7955-56
TR1-15/15	TRI	THY	VII		
TR1-40/15	TRI	THY	VII		7956-56
TR1-85/15	TRI	THY	VII		
TR1-130/15	TRI	THY	VII		

GROUP I, NUMERICAL

TYPE NUMBER	KIND	TYPE	TABLE NO.	SIMILAR TYPES	COST SPEC. NO.
TSG-1	PHO	XVI			
TSV-1	PHO	XVI			
TVB-1	THM	XVII I			
V1-00313	DIO	SIN	IV	V13/30+	
V1-02/20	DIO	SIN	IV		
V1-03/13	DIO	SIN	IV		
V1-05/70	DIO	SIN	IV		
V1-06/30	DIO	SIN	IV		
V1-1/2.5	DIO	SIN	IV		
V1-1/30	DIO	SIN	IV		
V1-1/40	DIO	SIN	IV		
V1-2/40	DIO	SIN	IV		
V1-3/16	DIO	SIN	IV		
V1-3/70	DIO	SIN	IV		
V1-4/40	DIO	SIN	IV		
V1-15/55	DIO	SIN	IV		
VD1	DIO	SIN		V1-1/40+	
VDI-1D	DIO	SIN		V1-1-100/50+	
VG1/8500	DIO	SIN	IV		
VG1.5/5000	DIO	SIN	IV	GG2-0.5/5+	
V1-1-5/20	DIO	SIN	IV		
V1-1-5/30	DIO	SIN	IV		
V1-1-18/32	DIO	SIN	IV		
V1-1-27/35	DIO	SIN	IV		
V1-1-30/25	DIO	SIN	IV		
V1-1-70/32	DIO	SIN	IV		
V1-1-100/50	DIO	SIN	IV		
VO-1	DIO	SIN	IV		
VSTS-1	PHO	XVI		F-3+	
VT-1	TRI	THY		TG-2.5/5+	
1A1P	PTG	SIN	II	1R5\$, DK91, DK192	
1A2P	PTG	SIN	II	DK96=, 1R5\$	
1B1P	PND	DIO	II	1S5\$, DAF91=, DAF191	8006-56
1B2P	PND	DIO	II	DAF96=, 1S5\$	
1B5-9	BAL	SIN	VI		
1B10-17	BAL	SIN	VI		
1E1P	TET	SIN	II		
1E3P	*TRI	SIN	II	EM-4+	
1I2P	PND	TRI	II		
1K1P	PND	SIN	II	1T4\$, DF91=	7707-55
1K2P	PND	SIN	II	DF96=, 1T4\$	
1N1	*TRI	TWN		1N35=	
1N3S	TRI	TWN	II	1N1+, 1G6-GTS	
1P2B	PND	SIN	II	CK507AX	
1P3B	PND	SIN	II		
1P4B	PND	SIN	II		
1P5B	PND	SIN	II		
1P22B	PND	SIN	II		
1P24B	PND	SIN	II		
1P32P	PND	SIN	II		
1S12P	TRI	SIN	II	DC96=	
1TS1	*DIO	SIN		1TS15+, 1VD1+	
1TS1S	DIO	SIN	II	1TS1+, 1VD1+	
1TS7S	DIO	SIN	II	DY30=, 1B3/8016\$	8359-57
1TS11P	DIO	SIN	II		
1TS21P	DIO	SIN	II		
1V3/8016	*DIO	SIN		1TS75+, 1B3/8016\$	
1VD1	*DIO	SIN		1TS1, 1TS15+	
1VD2	*DIO	SIN		1TS75+, 1B3/8016\$	
1ZH1ZH	PND	SIN	II		
1ZH2	*PND	SIN		1ZH2M+	
1ZH2M	PND	SIN	II	1ZH2*	
1ZH17B	PND	SIN	II		
1ZH18B	PND	SIN	II		
1ZH24B	PND	SIN	II		
1ZH29B	PND	SIN	II		
1ZH30B	PND	SIN	II		
1ZH36B	PND	SIN	II		
AS-2	COU	XXI			
D2A	*REC	XI		DG-TS9**	

GROUP I, NUMERICAL

TYPE NUMBER	KIND	TYPE	TABLE NO.	SIMILAR TYPES	COST SPEC. NO.
D2B	*REC	XI		DG-TS10**	
D2D	*REC	XI		DG-TS2**	
D2G	*REC	XI		DG-TS1**	
D2I	REC	GEP	XI		
D2K	REC	XI		DG-TS6**	
D2M	REC	XI		DG-TS7**	
D2N	REC	XI		DG-TS15**	
D2P	REC	XI		DG-TS16**	
D2R	REC	XI			
D2V	*REC	XI		DG-TS8+	
D2YE	*REC	XI		DG-TS4**	
D2ZH	*REC	XI		DG-TS5**	
DG-S2	MIX	XIV			
DG-TS2	REC	XI		D2D+	
D1-2-10	*DIO	SIN		2D1S+	
DK-12	MIX	XIV			
DK-S2	MIX	XIV			
DK-V2	DET	XIV			
DL-S2	MIX	XIV			
DSH2-10	*DIO	SIN		2D2S+	
F-2	PHO	XVI			
FD-2	PHC	XV			
FEU-2	PHM	XVI			
FEU-2B	PHM	XVI			
FEU-2B1V	PHM	XVI			
FEU-2M	PHM	XVI			
FEU-2V	PHM	XVI			
FS-B2	PHC	XV			
FS-K2	PHC	XV			
FS-2A	PHC	XV			
GE-2	TET	SIN	III	GKE-150=	
GMI-2B	TET	SIN	III		
G5-2B	TRI	SIN	III		
GU-2	BEA	SIN	II		
GUZH-2	BEA	SIN		G807+, 807\$	
GZH2	*PND	SIN		G413+	
I-2-50/1.5	TRI	IGN	IV		
KF-2	BEA	TWN		GU-32+, 832-A\$	
K5-2	TRI	SIN		GU-4+	
KZH-2	BEA	SIN		G-807+, 807\$	
MTI-2	TRI	THY		TGI-200+	
OG-2	DEC	XXIII			
P2A	X				
P2B	X			OC821=	
PT-2	TRI	THY		TG-213*	
R-2		XXII			
RB-2		XXII			
S2A	X				
S2B	X				
S2G	X				
S2V	X				
SG2P	DIO	SIN	V	OB2\$	
SG2S	DIO	SIN	V	OA3\$	
SI-2B	COU	XXI			
SI-2BG	COU	XXI			
ST2S	BAL	TWN	VI		
STS-2	COU	XXI			
STSV-2A	PHO	XVI		F-2+	
TG2-01/01	TRI	THY	VII		
TG2-0.5/12	TRI	THY	VII		
TG-2.5/5	TRI	THY	VII	VT-1	
TGI-2-260/12	TRI	THY	VII		
TGI-2-32516	TRI	THY	VII		
TGI-2-40035	TRI	THY	VII		
TKH-2	TRI	THY	VII		
TO-2	PND	SIN		10P12S+	
TV-2	THM	XVIII			
TVB-2	THM	XVIII			
VD2	DIO	SIN		V1-2/40+	
V1-2-27/35	DIO	SIN	IV		

GROUP I, NUMERICAL

TYPE NUMBER	KIND	TYPE	TABLE NO.	SIMILAR TYPES	COST SPEC. NO.
VI-2-70/32	DIO	SIN	IV		
VI-2-100/50	DIO	SIN	IV		
2A1	PTG	SIN	II	S0242** 2A1M	
2A1M	*PTG	SIN		S0242**	
2A3	TRI	SIN		2S45+, 2A3S	
2D1L	DWD	SIN	II		
2D1S	DIO	SIN	II	D1-2-10+	
2D2S	DIO	SIN	II	DSH2-10+	
2D3B	DIO	SIN	II		
2D3S	DIO	SIN	II		
2D7S	DIO	SIN	II		
2D9S	DIO	SIN	II		
2D21	TET	THY		TG3-0.1/1.3+, 2D21S	
2E1	*TET	SIN	II		
2E2	*TET	SIN	II	UB155+	
2E2P	TET	TWN	II		
2F2M	TRI	SIN			
2J55	MAG	IX			
2K1	*PND	II		2K1M+	
2K1M	*PND	SIN	II	2K1*, SB241*	
2K2	PND	SIN		2K2M*	
2K2M	*PND	SIN	II	2K2*, S0241*	
2KH1	*DWD	SIN		2KH1L+	
2KH1L	DWD	SIN	II	2KH1*	
2KH2	*DIO	SIN		2VD8A+, 2TS2S+, 2X2S	
2N1	TRI	DUO	II	SB243, S0243, 2N1M*	
2N1M	*TRI	DUO		2N1+, SB243+, S0243+	
2P1	BEA	SIN	II	SB244+, S0244+	
2P1M	*BEA	SIN		2P1P+, SB244	
2P1P	BEA	SIN	II	DL9A+, 2P1M	8005-56
2P2	*BEA	SIN	II		
2P2P	BEA	SIN	II	DL96+, 3S4S	
2P3	BEA	SIN	II	SB258+, S0258+, 2P2M+	
2P5B	PND	SIN	II		
2P9	*BEA	SIN		2P9M+, 2P9S	
2P9M	*BEA	SIN	II	2P9+, 2P9S, 6AK7	
2P9S	BEA	SIN		2P9M+, 2P9	
2P19B	PND	SIN	II		
2P21S	BEA	SIN			
2P29	*PND	SIN		2P29L+	
2P29L	PND	SIN	II		
2P29P	PND	SIN	II		
2S1	TRI	SIN	II	UB152+	
2S2	TRI	SIN	II	UB240+	
2S3	*TRI	SIN		2S45+, 2A3S	
2S3A	TRI	SIN			
2S3M	*TRI	SIN		2S2+	
2S4S	TRI	SIN	II	2A3S	
2S14B	TRI	SIN	II		
2S22	TRI	SIN		6S8S+, 2C22S	
2TM-20	TRI	SIN	III		
2TM-100	TRI	TWN	III		
2TS2S	DIO	SIN	II	2X2S	8527-57
2V6	DIO	ARC	IV		
2V12	DIO	ARC	IV		
2V20	DIO	ARC	IV		
2VD8	DIO	SIN	II		
2VN12	DIO	ARC	IV		
2VN20	DIO	ARC	IV		
2ZH1M	*PND	SIN	II	SB245+	
2ZH2B	PND	SIN			
2ZH2M	PND	SIN	II		
2ZH4	*PND	SIN	II	S0257+	
2ZH14B	PND	SIN	II		
2ZH15B	PND	SIN	II		
2ZH27	*PND	SIN		2ZH27L+	
2ZH27L	PND	SIN	II	2ZH27+	
2ZH27P	PND	SIN	II		
2ZH28L	PND	SIN	II		
D3A	DET	XIV			

GROUP I, NUMERICAL

TYPE NUMBER	KIND	TYPE	TABLE NO.	SIMILAR TYPES	COST SPEC. NO.
D3B	DET	XIV			
DG-S3	MIX	XIV			
DG-TS3	REC	XI			
DK-S3	MIX	XIV			
DK-V3	DET	XIV			
DL-S3	MIX				
EM-3	TET	SIN	II		
F-3	PHO	XVI			
FD-3	PHC	XV			
FEU-3B	PHM	XVI			
FEU-3M	PHM	XVI			
FEU-R3	PHM	XVI			
FS-3A	PHC	XV			
FS-K3	PHC	XV			
GI-3	TRI	SIN	III	2C26AS	
GI-3/100	TRI	SIN		GI-3+	
GK3A	TRI	SIN	III		
GMI-3	TET	SIN	III		
GS-3B	TET	SIN	III		
GU-3	BEA	SIN	II		
GUZH-3	BEA	SIN		G1625+, 1625S	
KF-3	BEA	SIN		GU-13+, 813S	
KZH-3	BEA	SIN		G-1625+, 1625S	
LI-3	IC	VIII			
LIM-3	LAM	XXIII			
MS3	*TRI	SIN		GM57+, UB180+, M457+	
OG-3	DEC	XXIII			
P3A	X				
P3B	X				
P3V	X				
PIM-3	IC	VIII			
PT-3	TRI	THY		TG-235**	
R-3		XXII			
RB-3		XXII			
S3A	X				
S3B	X				
S3D	X				
S3G	X				
S3V	X				
S3YE	X				
SBT-3	COU	XXI			
SG3P	REG	V			
SG2S	DIO	SIN	V	OC3S	
SI-3B	COU	XXI			
SMM-3	COU	XXI			
ST3P	DIO	SIN	VI		
STS-3	COU	XXI			
STSV-3	PHO	XVI			
TG3-01/13	TET	THY	VII	2D21S	
TG3-2.5/10	TRI	THY	VII		
TKH3B	TET	THY	VII		
TO-3	PND	SIN		7ZH12S+	
TS6-3	PHO	XVI			
TSV-3	PHO	XVI			
TVB-3	THM	XXVIII			
VDI-3D	DIO	SIN		VI-1-30/25+	
VT-3	TRI	THY		TRI-5/2**	
3A4S	PND	SIN	II		
3B4S	BEA	SIN	II		
3E29	*BEA	TWN		GI-30+, 3E29S	
3J21	MAG	IX			
3L01-I		VIII			
3S1	TRI	SIN	II	TO-141+	
3S2	TRI	SIN	II	TO-142+	
3S9	*TRI	SIN	II		
3TS16S	DIO	II			
3TS18P	*DIO	SIN			
3V30	DIO	ARC	IV		
3VN30	DIO	ARC	IV		
3VN60	DIO	ARC	IV		

GROUP I, NUMERICAL

TYPE NUMBER	KIND	TYPE	TABLE NO.	SIMILAR TYPES	COST SPEC. NO.
3VN100 3VP1	DIO	ARC	IV	8L029+, 3BP1A\$	
DG-S4	MIX		XIV		
DG-TS4	REC		XI	D2YE**	
DK-S4	MIX		XIV		
DK-V4	DET		XIV		
DL-S4	MIX				
EM-4	TRI	SIN	II	1E3P+	
F-4	PHO		XVI		
FS-A4	PHC		XV		
FS-K4	PHC		XV		
GI-4A	TRI	SIN	III		
GKV-4	TRI	SIN		GU-4+	
GMI-4B	TET	SIN	III		
GS-4	TRI	SIN	III		
GS-4	COU		XXI		
GS-4B	TRI	SIN		G431A+	
GS4D	TRI	SIN	III		
GU4	TRI	SIN	III		
GU4A	TRI	SIN	III		
KMT-4	TMS		XIX		
KS-4	TRI	SIN		GU-150+	
LIM-4	LAM		XXIII		
LP-4	COM		VII		
MMT-4	TMS		XIX		
MS-4	COU		XXI		
MSTR-4	COU		XXI		
MTI-4	TRI	THY		TGI-1-90/8+	
P4			X	2N68\$	
P4A			X		
P4B			X		
P4D			X		
P4G			X		
P4L			X		
P4V			X		
PIM-4	IC		VIII		
R-4			XXII		
S4A			X		
S4B			X		
S4G			X		
S4V			X		
SBS-4	COU		XXI		
SG4S	DIO	SIN	V	OD3\$	
SI-4G	COU		XXI		
STSV-4	PHO		XVI		
TGI-4	TRI	THY		TGI-1-130/10+	
TKH-4B	TET	THY	VII		
TO-4	PND	SIN		7P12S+	
TSG-4	PHO		XVI		
TSV-4	PHO		XVI		
TV-4	THM		XVIII		
TVB-4	THM		XVIII		
VDI-4D	DIO	SIN		VI-1-70/32+	
VS-4	COU		XXI		
4D2	*DIO	SIN		4TS6S+	
4D5S	*DIO	SIN	II		
4E1	*TET	SIN	II		
4E2	*TET	SIN	II		
4E3	*TET	SIN	II		
4F6S	BEA	SIN	II		
4J26-30	MAG		IX		
4J45	MAG		IX		
4J50	MAG		IX		
4N1	TRI	DUO	II	SB259+, S0259+	
4P1	*PND	SIN	II		
4P1L	PND	SIN	II		
4P2	PND	SIN			
4P6L	PND	SIN			
4P10S	PND	SIN	II		
4S1	TRI	SIN	II	UB107+	

GROUP I, NUMERICAL

TYPE NUMBER	KIND	TYPE	TABLE NO.	SIMILAR TYPES	COST SPEC. NO.
4S2	TRI	SIN	II	UB110+	
4S3	*TRI	SIN	II		
4S3S	TRI	SIN	II		
4S4	*TRI	SIN	II		
4S5	TRI	SIN	II	50-185+	
4TS1M	*DIO	SIN		4TS6S+	
4TS6S	DIO	SIN	II		
4TS14S	DIO	SIN	II		
4VD1	DIO	SIN	II		
4VKH1	*DIO	TWN	II	VO-188**	
4VKH2	*DIO	SIN	II	VO-188**	
42H1L	PND	SIN	II		
42H1P	PND	SIN	II		
42H4	PND	SIN		50124+	
42H5	*TET	SIN	II	42H5S+	
42H5S	PND	SIN	II		
DG-TS5	REC		XI	D22H**	
DK-S5	MIX				
DK-V5	DET		XIV		
F-5	PHO		XVI		
FEU-R5	PHM		XVI		
FS-K5	PHC		XV		
G-5	TRI	SIN		M39+	
G-5A	TRI	SIN		GU5A+	
G-5RA	TRI	SIN		GU-5B+	
GI-5B	TRI	SIN	III		
GK5A	TRI	SIN	III		
GMI-5	TET	SIN	III		
GS-5B	TRI	SIN		6433A+	
GU5A	TRI	SIN	III		
GU5B	TRI	SIN	III		
GU0-5	TRI	SIN		G120+	
LP-5	COM		VII		
MTI-5	*TRI	THY		TGI-1-32516+	
OG-5	DEC		XXIII		
P5A			X		
P5B			X	2N107\$	
P5D			X	CK727\$	
P5G			X	2N65\$	
P5V			X		
P5YE			X		
R-5			XXII		
RB-5			XXII		
RB-5A			XXII		
SBS-5	COU		XXI		
SG5B	DIO	SIN	V		
SG5B-V	REG		V		
SGS-5	COU		XXI		
SNM-5	COU		XXI		
STS-5	COU		XXI		
TKH-5A	TRI	THY	VII		
TV-5	THM		XVIII		
TVB-5	THM		XVIII		
UV-5	TWT		IX		
VG-5	POW		XII		
5L01B	*OS			5L038+, 2AP1\$	
5L0381	OS		VIII	2AP1\$	
5SR1	*OS			5CP1A\$	
5SR7	*OS			5CP7A\$	
5TS3S	DWD	SIN	II	5U4G\$	8360-57
5TS4	DIO	DUO		5TS4S+, 5Z4G\$	
5TS4M	DIO	DUO	II		
5TS4S	DIO	DUO	II	524\$	8079-56
5TS8S	DWD	SIN	II		8361-57
5TS9S	DWD	SIN	II	1502+	8362-57
5TS9SE	DWD	SIN	II		
5TS12P	DIO	SIN	II		
5VKH1	*DWD	SIN		5Z4G\$	
5VKH2	*DWD	SIN	II	5U4G\$	
5VKH3	*DWD	SIN	II	5Y3G\$	

GROUP I, NUMERICAL					
TYPE NUMBER	KIND	TYPE	TABLE NO.	SIMILAR TYPES	COST SPEC. NO.
D6	REG		XIII		
DG-TS6	REC		XI	D2K+	
DK-V6	DET		XIV		
F-6	PHO		XVI		
FS-A6	PHC		XV		
FS-D6	PHC		XV		
FS-K6	PHC		XV		
GI-6B	TRI	SIN	III		
GK6A	TRI	SIN	III		
GMI-6	BEA	TWN	III		
GS6	TRI	SIN	III		
GS-6	COU		XXI		
LD-6	TRI	SIN		GI-6B+	
LI-6	IC		VIII		
MMT-6	TMS		XIX		
MS-6	COU		XXI		
P6A			X		
P6B			X	OC821=	
P6D			X	OC812=	
P6G			X		
P6V			X	OC814=	
R6			XXII		
SGS-6	COU		XXI		
STS-6	COU		XXI		
STSV-6	PHO		XVI	F-4+	
TSV-6	PHO		XVI	F-5+	
TVB-6	THM		XVII		
UV-6	TWT		IX		
VS-6	COU		XXI		
6A1B	*PTG	SIN		6SA7\$	
6A2P	PTG	SIN	II	6BE6\$, EK90=	8354-57
6A3P	*GTB	SIN	II	6BN6\$	
6A5B	*PTG	SIN		6L7\$	
6A6A	*DIO				
6A7	PTG	SIN	II	6SA7\$	8086-56
6A8	PTG	SIN	II	6A8B+, 6A8\$	8367-57
6A8B	*PTG	SIN		6A8\$	
6A8M	*PTG	SIN		6A8\$**	
6A10S	PTG	SIN	II	6SA7\$	8087-56
6A15B	*PTG	SIN		6SA7\$	
6AG7	*BEA	SIN		6P9+, 6AG7\$	
6AZH5	*PND	SIN		6AG5\$ EF96=	
6B1P	PND	DIO	II		
6B2P	PND	DIO	II	L100**	
6B4	*TRI	SIN		6A3\$	
6B8	*PND	DWD		6B8\$, 6B8G\$, 6B8M*	
6B8M	*PND	DWD		6B8\$+, 6B8G\$	
6B8S	PND	DWD	II	6B8G\$, 6B8M*	8369-57
6BKH1	*DIO	DUO		6KH5\$+	
6D1A	*DIO	SIN		6D6A*, 5704\$	
6D1ZH	*DIO	SIN		6D4ZH*, 9004\$	
6D3D	DIO	SIN	II	559\$	
6D4ZH	DIO	SIN	II	9004\$	
6D6A	DIO	SIN	II	5704\$, *6D1A+	
6D8D	DIO	SIN	II		
6D10D	DIO		II		
6D13D	DIO	SIN	II		
6D14P	DIO	SIN	II		
6D20P	DIO	SIN	II		
6E5P	TET	SIN	II		
6E6P	BEA	SIN			
6E6P-YE	BEA	SIN	II	E7119+	
6F1P	PND	TRI	II	EF8D=, 6U8\$	
6F3P	TRI	PND	II		
6F4P	PND	TRI	II		
6F5	TRI	SIN		6S4B+, 6F5\$	
6F5B	TRI	SIN		6S4B+, 6F5\$	
6F5M	*TRI	II		6F5G\$, 6S4+	8372-57
6F5P	TRI	PND	II		
6F6	PND	SIN		6P6B+, 6F6\$	

GROUP I, NUMERICAL					
TYPE NUMBER	KIND	TYPE	TABLE NO.	SIMILAR TYPES	COST SPEC. NO.
6F6S	PND	SIN	II	6F6-GT\$	8082-56
6F7	PND	TRI	II		
6G1	TRI	DWD	II	6SR7\$	
6G2	TRI	DWD	II	6SQ7\$	8370-57
6G2P-K	TRI	DWD	II		
6G2S	*TRI	DWD		6SQ7G\$	
6G3P	TRI	TRD	II	6TB\$	
6G3S	*TRI	DWD			
6G7	TRI	DWD	II	6Q7=	8371-57
6I1P	PTG	TRI	II	ECH81=, 6AJ8\$	
6I14P	PTG	TRI	II	ECH81=, 6I1P+	
6K1B	PND	SIN	II	5702\$	
6K1L	PND	SIN	II		
6K1P	PND	SIN	II	9003\$	
6K1ZH	PND	SIN	II	956\$	
6K2P	*PND	SIN		6K4P+	
6K3	PND	SIN	II	6SK7\$	8084-56
6K4	PND	SIN	II	6SG7\$	8083-56
6K4P	PND	SIN	II	EF93=, 6BA6\$	8352-57
6K4P-E	DWD	SIN		6K4P	
6K6A	PND	SIN	II		
6K7	PND	SIN	II	6K7\$*, 6K7G\$, 6K9S+	8363-57
6K7S	*PND	SIN		6K9\$+, 6K7G\$, 6K7	
6K9S	PND	SIN	II	6K7G\$, 6SK7\$	
6K11B-K	PND	SIN	II	6K1B+	
6K12	*PND	SIN		6SG7	
6K13P	PND	SIN	II		
6K15B	*PND	SIN		6AB7\$	
6K17B	*PND	SIN		6SK7\$	
6K19B	*PND	SIN		9D03\$	
6K19P	*PND	SIN		6K1P+, 9003\$	
6KH1ZH	*DIO	SIN		6D4ZH+, 9004\$	
6KH2P	DIO	TWN	II	EAA91=, 6AL5\$	8348-57
6KH2P-E	DIO	TWN		6KH2P, E7099+	
6KH4P	DWD	SIN		6TS4P+	
6KH5	DWD	SIN		6VKH1+, 6X5GT\$	
6KH5S	DWD	SIN		6VKH1+, 6X5GT\$	
6KH6	DIO	TWN		6KH6B+, 6H6\$	
6KH6B	DIO	TWN	II	6H6-G\$	
6KH6M	DIO	TWN		6KH6S+, 6H6G\$	
6KH6S	DIO	TWN	II	6H6-G\$	8080-56
6KH7B	DIO	TWN	II		
6L7	PTG	SIN	II	6L7\$	
6LK1B	TV		VIII		
6N1P	TRI	TWN	II	6BK7\$	8355-57
6N1P-E	TRI	TWN		6N1P, E7100+	
6N2P	TRI	TWN	II	ECC83=, 6AX7\$	8356-57
6N2P-E	TRI	TWN		6N2P, E7101+	
6N3P	TRI	TWN	II	ECH42=, 2C51\$	8357-57
6N3P-E	TRI	TWN		6N3P, E7102+	
6N4P	TRI	TWN	II	12AY7\$	
6N5P	TRI	TWN	II		
6N5S	TRI	TWN	II	6AS7G\$	
6N6	DIO	TWN		6KH6B+, 6H6\$	
6N6P	TRI	TWN	II		
6N7	TRI	TWN	II	6N7\$, 6N7S+	
6N7S	TRI	TWN	II	6N7-GT\$	8374-57
6N8	TRI	TWN		6N8\$+, 6SN7GT\$	
6N8M	TRI	TWN		6N8\$+, 6SN7GT\$	
6N8S	TRI	TWN	II	6SN7-GT\$	
6N9	TRI	TWN		6N9\$+, 6SL7GT\$	
6N9M	TRI	TWN		6N9\$+, 6SL7GT\$	
6N9S	TRI	TWN	II	6SL7GT\$	
6N10	TRI	TWN		6N10\$+, 6SC7GT\$	
6N10M	TRI	TWN		6N10\$+, 6SC7GT\$	
6N10S	TRI	TWN	II	6SC7GT\$	
6N11	TRI	TWN		6N5\$+, 6AS7G\$	
6N12S	TRI	TWN	II	6DN7\$	
6N13S	TRI	TWN	II	6080\$	8378-57
6N14P	TRI	TWN	II	ECC84=, 6BX8\$	

GROUP I, NUMERICAL

TYPE NUMBER	KIND	TYPE	TABLE NO.	SIMILAR TYPES	COST SPEC. NO.
6N15	*TRI	TWN	II	6J6\$, 6N15P+	
6N15P	TRI	TWN	II	6J6\$, ECC91=	
6N16B	TRI	TWN	II		
6N17B	TRI	TWN	II		
6N18B	TRI	TWN	II		
6N19P	TTR	DWD	II		
6N23P	TRI	TWN	II		
6N24P	TRI	DUO	II		
6P1P	BEA	SIN	II	EL90=, 6AQ5\$	8358-57
6P2	BEA	SIN		6P6S+, 6V6GT\$	
6P2P	PND	SIN	II		
6P3	BEA	SIN		6P3S+, 6L6G\$	
6P3B	BEA	SIN		6P3S+, 6L6G\$	
6P3S	BEA	SIN	II	6L6G\$	8376-57
6P3S-YE	BEA	SIN		6P3S,E7121+	
6P4	*PND	SIN	II	6G6G\$	
6P6	BEA	SIN		6P6S+, 6V6GT\$	
6P6B	*PND	SIN	II	6F6\$	
6P6P	*BEA	SIN			
6P6S	BEA	SIN	II	6V6-GT\$	8375-57
6P7	*BEA	SIN		6P7S**, 6BG6GA\$	
6P7S	BEA	SIN	II	6P7**, 6BG6GA\$	
6P8P	TRI	SIN		6S1P+, 9002\$	
6P8S	*PND	SIN	II	6G6G\$	
6P9S	BEA	SIN	II	6AG7\$	8377-57
6P9E	BEA	SIN	II		
6P13S	BEA	SIN	II		
6P14P	BEA	SIN	II	EL84=, 6BQ5\$	
6P15P	BEA	SIN	II		
6P17S	BEA	SIN	II		
6P18P	BEA	SIN	II	EL82=	
6P20S	*BEA	SIN	II		
6P21S	*BEA	SIN	II		
6P25B	PND	SIN	II		
6P31S	BEA	SIN	II		
6P36S	BEA	SIN	II		
6R1B	TRI	DWD		6G1+, 6SR7\$	
6R7	TRI	DWD		6G7+, 6Q7\$	
6R7B	TRI	DWD		6G7+, 6Q7\$	
6R17B	TRI	DWD		6G2+, 6SQ7\$	
6S1B	TRI	SIN		6S6B+, 5703\$	
6S1P	TRI	SIN	II	9002\$	
6S1ZH	TRI	SIN	II	4671\$, 955\$	
6S2	TRI	SIN		6J5-GT\$	
6S2B	TRI	SIN	II	6S7B+, 5744\$	
6S2P	TRI	SIN	II	6J4\$	8353-57
6S2S	TRI	SIN	II	6J5-GT\$	8081-56
6S3B	TRI	SIN	II	6K4A\$	
6S3P	TRI	SIN	II		
6S4	*TRI	SIN		6F5\$	
6S4B	TRI	SIN	II	6F5\$	
6S4P	TRI	SIN	II		
6S4S	TRI	SIN	II	6B4-G\$	8373-57
6S5	TRI	SIN	II	6S5S+, 6C5GT\$	
6S5B	TRI	SIN		6C5-GT\$	
6S5D	TRI	SIN	II	TM1**, 2C40\$	
6S5S	TRI	SIN	II	6C5-GT\$	8368-57
6S6B	TRI	SIN	II	5703\$	
6S7B	TRI	SIN	II	5744\$	
6S8P	TRI	SIN		6S1P+, 9002\$	
6S8S	TRI	SIN	II	2C22\$	
6S9D	TRI	SIN	II		
6S10D	TRI	SIN	II		
6S11D	TRI	SIN	II		
6S13D	TRI	SIN	II		
6S15P	TRI	SIN	II		
6S16D	TRI	SIN	II		
6S17K	TRI	SIN	II		
6S18S	TRI	SIN	II		
6S19P	TRI	SIN	II		

GROUP I, NUMERICAL

TYPE NUMBER	KIND	TYPE	TABLE NO.	SIMILAR TYPES	COST SPEC. NO.
6S20S	TRI	SIN	II		
6S21D	*TRI	SIN	II		
6S25B	TRI	SIN	II		
6S26B	TRI	SIN	II	6S6B+	
6S27B	TRI	SIN	II	6S7B+	
6S28B	TRI	SIN	II		
6S29B	TRI	SIN	II		
6S30B	TRI	SIN	II		
6S33S	TRI	SIN	II		
6S34A-V	TRI	SIN	II		
6S35A-V	TRI	SIN	II		
6S36K	TRI	SIN	II		
6S37B	TRI	SIN	II		
6S39S	TRI	SIN	II		
6S47	PND	TRI	II		
6T54P	DWD	SIN	II	6X4\$	
6T54S	DIO	SIN	II		8347-57
6T55S	DWD	SIN	II	6X5GT\$	8528-57
6T510P	DIO	SIN	II	6B3\$	
6T513P	DIO	SIN	II		
6T515S	DIO	TWN	II		
6T517S	DIO	SIN	II		
6V1P	PND	SIN	II		
6VKH1	DWD	SIN	II		
6YE1P	TRI	SIN	II	EM80=, 6BR5\$	
6YE5	*TRI	SIN		6YE5S+	
6YE5S	TRI	SIN	II	6YE5*	8379-57
6ZH1B	PND	SIN	II	5702\$	
6ZH1L	PND	SIN	II		
6ZH1P	PND	SIN	II	6AK5\$, EF95=	
6ZH1P-E	PND	SIN		6ZH1P,E7112+	
6ZH1ZH	PND	SIN	II	954\$	
6ZH2B	PND	SIN	II	5784\$, 5639\$	
6ZH2M	PND	SIN	II	1851\$	
6ZH2P	PND	SIN		6ZH2P-E, E7113+	
6ZH2P-E	PND	SIN		6ZH2P,E7113+	
6ZH3	PND	SIN	II	6SH7\$	8085-56
6ZH3M	*PND	SIN	II	6AB7/1853\$	
6ZH3P	PND	SIN	II	6AG5\$, EF96=	8350-57
6ZH4	PND	SIN	II	6AC7\$	8364-57
6ZH4B	*PND	SIN		6AG7\$	
6ZH4E	PND	SIN	II		
6ZH4P	PND	SIN	II	6AU6\$, EF94=	
6ZH5	*TRI	SIN		6J5\$	
6ZH5A	*PND	SIN	II		
6ZH5B	PND	SIN	II		
6ZH5P	BEA	SIN	II	6AH6\$	8351-57
6ZH6M	*PND	SIN		6J7\$	
6ZH6P	*PND	SIN		6J7\$	
6ZH6S	PND	SIN	II	Z62=	
6ZH7	PND	SIN	II	6J7	8365-57
6ZH7B	*PND	SIN		6W7G\$	
6ZH8	PND	SIN	II	6SJ7\$	8366-57
6ZH8S	PND	SIN	II		
6ZH9B	PND	SIN	II		
6ZH9P	PND	SIN	II		
6ZH9P-E	PND	SIN		6ZH9P,E7114+	
6ZH10B	PND	SIN	II		
6ZH10P	PND	SIN	II		
6ZH11B	*PND	SIN		6SH7\$	
6ZH11P	PND	SIN	II	6B05\$	
6ZH11P-EPND	SIN			6ZH11P+, E7115+	
6ZH12B	*PND	SIN		6SG7\$	
6ZH13	PND	SIN		6ZH13L+	
6ZH13L	PND	SIN	II	6ZH13	
6ZH20P	BEA	DIO	II		
6ZH21P	BEA	DIO	II		
6ZH22P	DIO	BEA	II		
6ZH23P	PND	DBA	II		
6ZH31BK	PND	SIN	II	EF95=	

GROUP I, NUMERICAL					
TYPE NUMBER	KIND	TYPE	TABLE NO.	SIMILAR TYPES	GOST SPEC. NO.
6ZH32P	PND	SIM	II		
6ZH33A	PND	SIM	II		
6ZH33AV	PND	SIM	II		
6ZH35BV	PND	SIM	II		
D7	REG		XIII		
D7A	REC	XI		DG-TS21**	
D7B	REC	XI		DG-TS22**	
D7D	REC	XI		DG-TS25**	
D7G	REC	XI		DG-TS24**	
D7V	REC	XI		DG-TS23**	
D7YE	REC	XI			
D7ZH	REC	XI		DG-TS27**	
DG-TS7	REC	XI		D2M+	
DK-S7	MIX	XIV			
DK-V7	DET	XIV			
EM-7	TRI	SIM	II		
FS-K7	PHC	XV			
G1-7B	TRI	SIM	III		
GMI-7	TET	SIM	III		
GS-7	COU		XXI		
GS-7	TRI	SIM		GK-3000+	
GS-7A	TRI	SIM	III		
GS-7B	TRI	SIM	III		
KS-7	TRI	SIM		G-811+, 811-A5	
LD-7	TRI	SIM		G1-7B+	
LI-7	IC		VIII		
MS-7	COU		XXI		
P7			X		
R-7			XXII		
SAT-7	COU		XXI		
SBM-7	COU		XXI		
SBT-7	COU		XXI		
SG7S	DIO	SIM	V		
SMM-7	COU		XXI		
TVB-7	THM		XVIII		
UV-7	TWT		IX		
7LO1M	OS		VIII		
7LO55I	OS		VIII	3MP1s	
7P12S	PND	SIM	II		
7ZH12S	PND	SIM	II	328As	
D8	REG		XIII		
DG-TS8	REC	XI		D2V+	
F-8	PHO		XVI		
G1-8	PND	SIM	III		
FS-K8	PHC		XV		
GS-8	COU		XXI		
GU8	TRI	SIM	III		
KMT-8	TMS		XIX		
MMT-8	TMS		XIX		
MS-8	COU		XXI		
P8			X		
P8A			X		
R-8			XXII		
SAT-8	COU		XXI		
SBM-8	COU		XXI		
SBT-8	COU		XXI		
SG8S	DIO	SIM	V		
SMM-8	COU		XXI		
STS-8	COU		XXI		
T8D	TMS		XIX		
T8E	TMS		XIX		
T8M	TMS		XIX		
T8R	TMS		XIX		
T8S1	TMS		XIX		
T8S1M	TMS		XIX		
T8S2	TMS		XIX		
T8S2M	TMS		XIX		
T8S3	TMS		XIX		
T8S3M	TMS		XIX		
TG8/3	TRI	THY		TG1-2.5/4+	

7711-55

GROUP I, NUMERICAL					
TYPE NUMBER	KIND	TYPE	TABLE NO.	SIMILAR TYPES	GOST SPEC. NO.
TVB-8	THM		XVIII		
V5-8	COU		XXI		
8LM3V	OS		VIII		
8LO2B	OS			8LO29+, 3BP1As	
8LO29I	OS		VIII	3BP1s	
8LO29M	OS		VIII		
8LO30I	OS		VIII	3DP1s	
8LO30M	OS		VIII		
8LO39V	OS		VIII	3JP7s	
D9A	REC		XI		
D9B	REC		XI		
D9D	REC		XI		
D9G	REC		XI		
D9I	REC		XI		
D9K	REC		XI		
D9L	REC		XI		
D9M	REC		XI		
D9V	REC		XI		
D9YE	REC		XI		
D9ZH	REC		XI		
DG-TS9	REC		XI	D2A+	
G-9	TRI	SIM		GU65+	
GS-9	COU		XXI		
GS9B	TRI	SIM	III		
LD-9	TRI	SIM		GS-9B+	
MMT-9	TMS		XIX		
MS-9	COU		XXI		
P9			X	2N35s	
P9A			X		
R-9			XXII		
SG9S	DIO	SIM	V		
SMM-9	COU		XXI		
STSV-9	PHO		XVI	F-1+	
T9	TMS		XIX		
TVB-9	THM		XVIII		
V5-9	COU		XXI		
D10	REC		XI		
D10A	REC		XI		
D10B	REC		XI		
DGTS10	REC		XI	D2B+	
G10	TRI	SIM	III		
G-10A	TRI	SIM		GU-10A+	
G-10RA	TRI	SIM		GU-10B+	
GK0-10	TRI	SIM		GK-2000+	
GS-10	COU		XXI		
GT-10	TRI	SIM		G46+	
GU10A	TRI	SIM	III		
GU10B	TRI	SIM	III		
ISK10			XX		
ISP10			XX		
IST10			XX		
KMT-10	TMS		XIX		
MO-10	TRI	SIM	III		
P10			X	2N35s	
P10A	GAP		X		
P10B	GAP		X		
R-10			XXII		
SBT-10	COU		XXI		
SG10S	REG		V		
TO-10	PND	SIM		10P12S	
VG-10	POW		XII		
VG-10-30	POW		XII		
VG-10-45	POW		XII		
VG-10-55	POW		XII		
VG-10-80	POW		XII		
VG-10-110	POW		XII		
VG-10-150	POW		XII		
VK-10	POW		XII		
VKU-10-0.25	SCR	S14	XII-A		
VKU-10-0.5	SCR	S14	XII-A		

GROUP I, NUMERICAL

TYPE NUMBER	KIND	TYPE	TABLE NO.	SIMILAR TYPES	COST SPEC. NO.
VKU-10-0.75	SCR	SI4	XII-A		
VKU-10-1.0	SCR	SI4	XII-A		
VKU-10-1.5	SCR	SI4	XII-A		
VKU-10-2.0	SCR	SI4	XII-A		
VKU-10-2.5	SCR	SI4	XII-A		
VKU-10-3.0	SCR	SI4	XII-A		
10LK2B	PR	VIII			
10LO43I	OD	VIII			
10P12S	PND	SIM	II		
102H1L	PND	SIM	II	102H3L+	
102H3L	PND	SIM	II	102H1L+	
102H3P	PND	SIM	II	310A\$	
102H12S	PND	SIM	II		
D11	REC	XI			
FEU-11	PHM	XVI			
GI-11B	TRI	SIM	III		
GS-11	COU	XXI			
GU11A	TRI	SIM	III		
GU11B	TRI	SIM	III		
KMT-11	TMS	XIX			
LD11	TRI	SIM		GI-11B+	
MS-11	COU	XXI			
P11	X			2N94\$	
P11A	GAP	X			
R-11		XXII			
VS-11	COU	XXI			
D12	REC	XI			
D12A	REC	XI			
DGTS12	REC	XI			
FEU-12	PHM	XVI			
GI-12B	TRI	SIM	III		
GS-12	COU	XXI			
GU12A	TRI	SIM	III	880\$	
KMT-12	TMS	XIX			
LD12	TRI	SIM		GI-12B\$	
MMT-12	TMS	XIX			
MS-12	COU	XXI			
OS12/500	*PND	SIM		G837-	
P12	X				
P12A	GAP	X			
R-12		XXII			
12B1M	PND	DWD	II		
12B2M	PND	DWD	II		
12G1	TRI	DWD	II	12SR7\$	
12G2	TRI	DWD	II	12SQ7\$	
12K1M	PND	SIM	II		
12K3	PND	SIM	II	12SK7\$	
12K4	PND	SIM	II	12SG7\$	
12K12B	*PND	SIM		12SG7\$	
12K17B	*PND	SIM		12SK7\$	
12KH3S	DWD	SIM	II	LG1	
12M1M	PND	TRI	II		
12N1	TRI	TWN		12N11S+, 12AH7GT\$	
12N4P	TRI	TWN	II	12AY7\$	
12N10	TRI	TWN		12N10S+, 12SC7GT\$	
12N10M	TRI	TWN		12N10S+, 12SC7GT\$	
12N10S	TRI	DUO	II	12SC7\$	
12N11S	TRI	TWN	II	12AH7GT\$	
12P4S	PND	SIM	II		
12P14S	BEA	SIM	II		
12P17L	PND	SIM	II		
12R1B	TRI	DWD		12G1+, 12SR7\$	
12R17B	TRI	DWD		12G2+, 12SQ7\$	
12S2	*TRI	SIM	II		
12S3S	*TRI	SIM	II	LD1+	
12ZH1	*PND	SIM		12ZH1L+	
12ZH1L	PND	SIM	II	12ZH1	
12ZH1M	PND	SIM	II		
12ZH3L	PND	SIM	II		
12ZH8	PND	SIM	II	12SJ7\$	

GROUP I, NUMERICAL

TYPE NUMBER	KIND	TYPE	TABLE NO.	SIMILAR TYPES	COST SPEC. NO.
12ZH8B	*PND	SIM		12SJ7\$	
12ZH17B	*PND	SIM		12SJ7\$	
D13	REC	XI			
DGTS13	REC	XI			
FEU-13	PHM	XVI			
G-13	TRI	SIM	III		
GI-13	TRI	SIM	III		
GI-13B	TRI	SIM	III		
GM13	TET	SIM	III		
GU13	BEA	SIM	III	813\$	
LI-13	IM	VIII			
MS-13	COU	XXI			
P13	X			2N43\$	
P13A	X			2N34\$	
P13B	X				
SG13P	DIO	SIM	V		
V13/30	*DIO	SIM	IV	V1-003/13+	
VS-13	COU	XXI			
13LK1B	TV	VIII		5FP4\$	
13LK2B	TV	VIII			
13LM4V	OS	VIII			
13LM31M	OS	VIII		5FP7\$	
13LM31V	OS	VIII			
13LM56I	OS	VIII		5FP1\$	
13LM57	OS	VIII		5FP7\$	
13LM57D	OS	VIII			
13LM58K	OS	VIII			
13LO1B	*	VIII			
13LO2B	*	VIII		5CP1-A*\$	
13LO3I	OS	VIII			
13LO4I	OS	VIII			
13LO5P	*	VIII		5CP7-A\$	
13LO6P	*	VIII		5FP7-A\$	
13LO36	OS	VIII		5FP7\$, L0736+	
13LO36V	OS	VIII			
13LO37A	OS	VIII			
13LO37I	OS	VIII		5CP1\$, L0737+	
13LO37M	OS	VIII			
13LO48A	OD	VIII		L0748+	
13LO48I	OD	VIII		5SP1\$	
13LO48M	OD	VIII			
13LO54A	OS	VIII		L0754	
13LO54M	OS	VIII			
13LO54V	OS	VIII			
13LO101M		VIII			
13LO102M		VIII			
13LO104A	TV	VIII			
13P1	*BEA	SIM		13P1M+, 13P15+	
13P1M	BEA	SIM		13P1+, 13P15+	
13P1S	BEA	SIM	II	13P1+, 13P1M+	
D14	REC	XI			
D14A	REC	XI			
DGTS14	REC	XI			
FEU-14	PHM	XVI			
GI-14B	TRI	SIM	III		
LI-14	IM	VIII			
MS-14	COU	XXI			
P14	X			2N65\$	
P14A	X				
P14B	X				
TV-14	TWM	XVIII			
VS-14	COU	XXI			
D15	REC	XI			
DGTS15	REC	XI		D2N+	
FEU-15	PHM	XVI			
G-15A	TRI	SIM		GU-11A+	
G-15RA	TRI	SIM		GU-16B+	
GDO-15	TRI	SIM		G-61+	
GU15	BEA	SIM	III		
IFK15-1		XX			

GROUP I, NUMERICAL					COST SPEC. NO.
TYPE NUMBER	KIND	TYPE	TABLE NO.	SIMILAR TYPES	
ISSH15			XX		
LI-15	IM		VIII		
P15			X	2N435, OC604=	
P15A	GAP		X		
SG15P	DIO	SIN	V		
SG15P1	DIO	SIN	V		
TG-15/3	TRI	THY		TG1-5/3+	
TR-15/2	TRI	THY		TR-1-5/2+	
TV-15	THM		XVIII		
VG15/5000	DIO	SIN		GG1-0.5/5+	
15A6S	PND	SIN	II		
D16	REC		XI		
D16A	REC		XI		
DGTS16	REC		XI	D2P+	
FEU-16	PHM		XVI		
GI-16B	TET	SIN	III		
GU16B	TRI	SIN	III		
LG-16	DIO	SIN		2D25+	
MS-16	COU		XXI		
P16			X	2N555, OC604=	
P16A			X		
P16B			X		
SG16P	DIO	SIN	V		
TV-16	THM		XVIII		
VS-16	COU		XXI		
D17	REC		XI		
DGTS17	REC		XI		
FEU-17	PHM		XVI		
FEU-17A	PHM		XVI		
G-17B	TRI	SIN	III		
GI-17	TRI	SIN	III	G480*	
GU-17	BEA	TWN	III		
LI-17	IM		VIII		
MST-17	COU		XXI		
P17			X		
P17A			X		
P17B			X		
SG17S	DIO	SIN	V		
D18	GEP		XI		
FEU-18	PHM		XVI		
FEU-18A	PHM		XVI		
GI-18B	TRI	SIN	III		
GS-18	TRI	SIN		GK-2000+	
GU-18	BEA	TWN	III		
LI-18	VI		VIII		
P18			X		
P18A			X		
P18B			X		
SG18S	DIO	SIN	V		
18LK1B	TV		VIII		
18LK2B	TV		VIII	70P4S	
18LK3V	*		VIII		
18LK4B	TV		VIII		
18LK5B	TV		VIII		
18LK7B	TV		VIII		
18LK15	TV		VIII		
18LM35	OS		VIII	7BP7AS	
18LM35V	OS		VIII		
18L01P	*		VIII	7BP7AS	
18L040B	TV		VIII	7JP4S, LK740+	
18L047A	OD		VIII		
18L047V	OD		VIII		
D19	GEP		XI		
D19A	GEP		XI		
D19B	GEP		XI		
FEU-19M	PHM		XVI		
GI-19B	TRI	SIN	III		
GU-19	BEA	TWN	III		
P19			X		
SG19S	DIO	SIN	V		

GROUP I, NUMERICAL					COST SPEC. NO.
TYPE NUMBER	KIND	TYPE	TABLE NO.	SIMILAR TYPES	
19LK4B	TV		VIII		
D20	GEP		XI		
FEU-20	PHM		XVI		
GK20	TRI	SIN	III		
I-20/1.5	TRI	IGN	IV		
IFK20			XX		
M-20/35	TRI	SIN		GM-1A+	
MO20	TRI	SIN	III		
P20			X		
QV20-P18	*TET	SIN		GM1-83=	
SG20G	DIO	SIN	V		
T-20BFL	COU		XXI		
TR-20/15	TRI	THY		TR-1-6/15+	
V20/20	*DIO	SIN		V1-0.02/20+	
VKU-20-0.25	SCR	S14	XII-A		
VKU-20-0.5	SCR	S14	XII-A		
VKU-20-0.75	SCR	S14	XII-A		
VKU-20-1.0	SCR	S14	XII-A		
VKU-20-1.5	SCR	S14	XII-A		
VKU-20-2.0	SCR	S14	XII-A		
VKU-20-2.5	SCR	S14	XII-A		
VKU-20-3.0	SCR	S14	XII-A		
20LM1YE			VIII		
D21	REC		XI		
DGTS21	REC		XI	D7A+	
GI-21B	TRI	SIN	III		
GU21B	TRI	SIN	III		
P21			X		
P21A			X		
DGTS22	REC		XI	D7B+	
FEU-22	PHM		XVI		
GI-22	TRI	SIN	III		
GU22A	TRI	SIN	III		
P22			X		
DGTS23	REC		XI	D7V+	
FEU-23	PHM		XVI		
GU23A	TRI	SIN	III		
GU-23B	TRI	SIN	III		
LI-23			VIII		
P23			X		
23LK1B	TV		VIII	9CP4S	
23LK2B	TV		VIII		
23LK7B	TV		VIII		
23LK8B	TV		VIII		
23LM34	OS		VIII	9GP7S	
23LM34V	OS		VIII		
23L01P	OS		VIII	9GP7S	
23L051A	OS		VIII		
DGTS24	REC		XI	D7G+	
FEU-24	PHM		XVI		
GI-24A	TRI	SIN	III		
GU24A			III		
DGTS25	REC		XI	D7D+	
FEU-25	PHM		XVI		
GI-25	TRI	SIN	III		
GU25B	TRI	SIN	III		
ISK25			XX		
P25			X		
P25A			X		
P25B			X		
T-25BFL	COU		XXI		
VK-25	POW		XII		
25P1	BEA	SIN	II	25L6S	
25P1S	BEA	SIN	II	25L6S	
DGTS26	REC		XI	D7E+	
FEU-26L	PHM		XVI		
GU26A	TRI	SIN	III		
GU26B	TRI	SIN	III		
P26			X		
P26A			X		

GROUP I, NUMERICAL					
TYPE NUMBER	KIND	TYPE	TABLE NO.	SIMILAR TYPES	COST SPEC. NO.
P26B			X		
DGTS27	REC		XI	D7Z+	
FEU-27	PHM		XVI		
GU27A	TET	SIN	III		
GU27B	TET	SIN	III	827-R5	
P27			X		
P27A			X		
GU28A	TET	SIN	III		
GU28B	TET	SIN	III		
M28	TRI	SIN	III		
P28			X		
FEU-29	PHM		XVI		
G29	TRI	SIN	III		
GU29	TET	TWN	III	829-B5	
K-29	KLY		IX		
P29			X		
P29A			X		
GDO-30	TRI	SIN		GS-3B+	
GI-30	BEA	TWN	III	3E295	
GMI-30	TRI	SIN	III		
GS-30	COU		XXI		
GU30A	TRI	SIN	III		
K-30	KLY		IX		
M-30/450	TRI	SIN		GMI-30+	
P30			X		
T-30BFL	COU		XXI		
VG-30	POW		XII		
30LK1B	TV		VIII	31LK1B+	
30P1	BEA	SIN		30P1S+	
30P1M	*BEA	SIN		30P1S+	
30P1S	BEA	SIN	II	30P1M	
30TS1M	DIO	SIN	II	30VKH1+, 30TS6S+	
30TS6S	DIO	TWN	II	30VKH1+, 30TS14*	8078-56
30VD1	DIO	SIN	II	30TS1M+	
30VKH1	DIO	SIN	II	30TS6S+	
FEU-31	PHM		XVI		
GU31	TET	SIN	III		
K-31	KLY		IX		
31LK1B	TV		VIII		
31LK2B	TV		VIII	12LP45	
31LM32	OS		VIII	12DP7A5	
31LM32V	OS		VIII		
31L01P	OS		VIII	12DP7S	
31L033	OS		VIII	126P7S	
31L033V	OS		VIII		
FEU-32	PHM		XVI		
G32	TRI	SIN	III		
GU32	BEA	TWN	III	8325	
K-32	KLY		IX		
FEU-33	PHM		XVI		
GU33B	TET	SIN	III		
K-33	KLY		IX		
FEU-34	PHM		XVI		
GU34B	TET	SIN	III		
K-34	KLY		IX		
FEU-35	PHM		XVI		
GU-35B	TET	SIN	III		
K-35	KLY		IX		
35LK2B	TV		VIII		8815-58
FEU-36	PHM		XVI		
G36	TRI	SIN	III		
GK36	TRI	SIN		GK-20+	
GU-36B	TET	SIN	III		
FEU-37	PHM		XVI		
GU-37B	TRI	SIN	III		
FEU-38	PHM		XVI		
FEU-39	PHM		XVI		
GU-39A	TET	SIN	III		
GU-39B	TET	SIN	III		
M39	TRI	SIN	III		

GROUP I, NUMERICAL					
TYPE NUMBER	KIND	TYPE	TABLE NO.	SIMILAR TYPES	COST SPEC. NO.
FEU-40	NSP		XVI		
GU-40B	TET	SIN	III		
T-40BFL	COU		XXI		
V40/100	DIO	SIN		V1-0.1/40+	
40LK1B	TV		VIII	16AP45	
K-41	KLY		IX		
FEU-42	NSP		XVI		
K42	KLY		IX		
P42A			X		
P42B			X		
42LM2YE			VIII		
FEU-43	NSP		XVI		
43LK2B	TV		VIII		
43LK3B	TV		VIII		
43LK6B	TV		VIII		
43LK7B	TV		VIII		
43LK8B	TV		VIII		
43LK9B	TV		VIII		
FEU-44	NSP		XVI		
FEU-45	NSP		XVI		
45LM1B			VIII		
FEU-46	NSP		XVI		
G46	TRI	SIN	III		
47LK1B	TV		VIII		
FEU-47	NSP		XVI		
G47	TRI	SIN	III		
SB-47	PND	SIN	II		
FEU-48	NSP		XVI		
K48			IX		
FEU-49	PHM		XVI		
G-49	TRI	SIN		GS-4+	
GD-50	TRI	SIN		G-46+	
GU50	PND	SIN	III	LS50=	
I-50/1.5	TRI	IGN	IV		
I-50/1500	DIO	IGN	IV		
IFK50			XX		
LS50	*PND	SIN	II	GU50=	
M50	TRI	SIN	III		
T-50BFL	COU		XXI		
VG-50	POW		XII		
VK-50	POW		XII		
VKU-50-0.25	SCR	S14	XII-A		
VKU-50-0.5	SCR	S14	XII-A		
VKU-50-0.75	SCR	S14	XII-A		
VKU-50-1.0	SCR	S14	XII-A		
VKU-50-1.5	SCR	S14	XII-A		
VKU-50-2.0	SCR	S14	XII-A		
VKU-50-2.5	SCR	S14	XII-A		
VKU-50-3.0	SCR	S14	XII-A		
GM51A	TRI	SIN	III		
SB-51	PND	SIN	II		
STSV51	PHO		XVI		
FEU-52	PHM		XVI		
FEU-53	PHM		XVI		
M53	TRI	SIN	III		
53LK2B	TV		VIII		
53LK3B	TV		VIII		
53LK4TS			VIII		
53LK5B	TV		VIII		
53LK6B	TV		VIII		
G-54	TRI	SIN		GS-6+	
R-54			XXII		
G-56	TRI	SIN		G29+	
GM57	TRI	SIN	III	MS50*+, M457+, UB180=	
M57	TRI	SIN	III		
SO-57	PND	SIN	II		
G-58	TRI	SIN		GK-3000+	
59LK1B	TV		VIII		
GM60	TRI	SIN	III	M600*+	
GS-60	COU		XXI		

GROUP I, NUMERICAL

TYPE NUMBER	KIND	TYPE	TABLE NO.	SIMILAR TYPES	COST SPEC. NO.
T-608FL	COU		XXI		
G61	TRI	SIN	III		
G62	TRI	SIN	III		
G-64	TRI	SIN		GS-38+	
G65	TRI	SIN	III		
G68	TRI	SIN	III		
G1-708	TRI	SIN	III		
GM-70	TRI	SIN	III		
GM708	TRI	SIN	III		
ISP70			XX		
LD70	TRI	SIN		GI-708+	
V70/1000	DIO	SIN		V1-0.3/70+	
GK71	PND	SIN	III	G471+	
GU72	PND	SIN	III		
M74	TRI	SIN	III		
75S5-30	*DIO	SIN		SG2S+, OA3S	
G1-768	TRI	SIN	III		
GU80	PND	SIN	III	OS450+, P800**	
M80	TRI	SIN	III		
T-808FL	COU		XXI		
GU81	PND	SIN	III		
GMI-83	TET	SIN	III	QV20-P18=	
G88	TRI	SIN	III		
VO-88	DIO	TWN		4VKH1+	
GMI-89	TET	SIN	III	G-489**	
GU89A	TRI	SIN	III	889AS	
GU89B	TRI	SIN	III	889R-AS	
M89	TRI	SIN	III		
GMI-90	TET	SIN	III	G-490**	
GS908	TRI	SIN	III		
LD-90	TRI	SIN		GS-90B+	
MTKH90	TRI	THY	VII		
RB-90			XXII		
TGI-90/8	TRI	THY		TGI-1-90/8+	
G91	TRI	SIN	III		
G-92	TRI	SIN		GK-2000+	
L-99	PTG	SIN		6A2P+, 68E6S	
G-100	TRI	SIN		G-29+	
G-100A	TRI	SIN		GK-3A+	
GD-100	TRI	SIN		G-47+	
GKE100	*TET	SIN	III	GE-1=	
GM100	TRI	SIN	III		
I-100/1.0	TRI	IGN	IV		
I-100/5.0	TRI	IGN	IV		
ISSH100-1			XX		
ISSH100-3			XX		
L100	*PND	DIO		6B2P*	
VG-100	POW		XII		
VK-100	POW		XII		
VKU100-0.25	SCR	S14	XII-A		
VKU100-0.5	SCR	S14	XII-A		
VKU100-0.75	SCR	S14	XII-A		
VKU100-1.0	SCR	S14	XII-A		
VKU100-1.5	SCR	S14	XII-A		
VKU100-2.0	SCR	S14	XII-A		
VKU100-2.5	SCR	S14	XII-A		
VKU100-3.0	SCR	S14	XII-A		
VKUV-100-0.25	SCR	S14	XII-A		
VKUV-100-0.5	SCR	S14	XII-A		
VKUV-100-0.75	SCR	S14	XII-A		
VKUV-100-1.0	SCR	S14	XII-A		
VKUV-100-1.5	SCR	S14	XII-A		
VKUV-100-2.0	SCR	S14	XII-A		
VKUV-100-2.5	SCR	S14	XII-A		
VKUV-100-3.0	SCR	S14	XII-A		
D101	REC		XI		
D101A	REC		XI		
L1-101	IC		VIII		
P101			X		
P101A			X		

GROUP I, NUMERICAL

TYPE NUMBER	KIND	TYPE	TABLE NO.	SIMILAR TYPES	COST SPEC. NO.
P101B			X		
D102	REC		XI		
D102A	REC		XI		
P102			X		
D103	REC		XI		
D103A	REC		XI		
P103			X		
S-103	TET	SIN		GKE-1000+	
D104	REC		XI		
D104A	REC		XI		
L-104	PND	SIN		6K4P+, 6BA6S	
P104			X		
D105	REC		XI		
D105A	REC		XI		
P105			X		
105S5-30	DIO	SIN		SG3S+, OC3S	
D106	REC		XI		
D106A	REC		XI		
P106			X		
S-106	TET	SIN		GKE-150+	
D107	REC	SIP	XI		
D107A	REC	SIP	XI		
P107			X		
UB107	*TRI	SIN		4S1+	
D108	REC	SIP	XI		
GT108A			X		
GT108B			X		
GT108C			X		
GT108V			X		
D109	REC	SIP	XI		
GT109A			X		
GT109B			X		
GT109G			X		
GT109V			X		
S-109	TET	SIN		GKE-300+	
UB110	*TRI	SIN		4S2+	
VU-111D	DIO	SIN	IV		
S8-112	PND	SIN	II	4E1+	
S0-118	TRI	SIN		4S5+	
G120	TRI	SIN	III		
IFK120			XX		
TR-120/15	TRI	THY		TR-1-40/15+	
S0-122	PND	SIN		4P1+	
S0-124	PND	SIN	II	4ZM5+	
V0-125	DIO	SIN	IV		
SK-127			XXII		
VG-129	DIO	SIN	IV		
UB-132	*TRI	SIN	II	4S3+	
P135			X		
TO-141	*TRI	SIN	II	3S1+	
TO-142	*TRI	SIN	II	3S2+, 3S9+	
S8-147	TET	SIN		4E2+	
S0-148	PND	SIN	II	4E3+	
G1-150	TRI	SIN	III		
GKE150	*TET	SIN	III	GE-2=	
GU150	TRI	SIN	III		
I-150/1.0	TRI	IGN	IV		
M150	TRI	SIN	III		
150S5-30	*DIO	SIN		SG4S+, OD3S	
S8-152	TRI	SIN	II		
UB-152	TRI	SIN	II	2S1+	
UB-153	TRI	SIN	II		
S8-154	PND	SIN	II	2E1+	
S8-155	BEA	SIN		2P2+	
UB-155	*BEA	SIN	II	2E2+	
2S-156A	REG		XIII		
VG-161	DIO	SIN	IV		
VG-163	DIO	SIN	IV		
2S-168A	REG		XIII		
VG-176	DIO	SIN	IV		

7712-55

GROUP I, NUMERICAL

TYPE NUMBER	KIND	TYPE	TABLE NO.	SIMILAR TYPES	COST SPEC. NO.
UB-178	TRI	SIN	II		
SO-182	PND	SIN	II		
UB-182	*TRI	SIN	II		
SO-185	TRI	SIN		4S5+	
U0186	*TRI	SIN	II	4S4+	
US-186	TRI	SIN		4S4+	
VO-188	DWD	SIN	IV	4VKH1*	
SB-190	PND	SIN	II		
191P	TET	SIN	II		
VO-196	DIO	SIN	IV		
VO-197	DWD	SIN	IV		
GD-200	TRI	SIN		GS-4+	
I-200/1.5	TRI	IGN			
IFF200			XX		
IVS200/2		IGN	IV		
TGI-200	TRI	THY	VII	MTI-2+	
VG200	POW		XII		
VK-200	POW		XII		
VKV200	POW		XII		
D201A	REC		XI		
D201B	REC		XI		
D201D	REC		XI		
D201G	REC		XI		
D201TS	REC		XI		
D201V	REC		XI		
D201YE	REC		XI		
D201ZH	REC		XI		
LI-201	IM		VIII		
P201			X		
P201A			X		
SG201S	DIO	SIN	V		
D202	REC		XI	2N68S	
P202			X		
SG202B	DIO	SIN	V		
VO-202	DWD	SIN	IV		
D203	REC		XI		
LI-203			VIII		
P203			X	2N68S	
SG203K	DIO	SIN	V		
D204	REC		XI		
D205	REC		XI		
D206	REC		XI		
D207	REC		XI		
P207			X		
P207A			X		
D208	REC		XI		
P208			X		
P208A			X		
D209	REC		XI		
P209			X		
P209A			X		
D210	REC		XI		
P210			X		
P210A			X		
D211	REC		XI		
P211			X		
P212			X		
P212A			X		
TG212M	TRI	THY	VII		
P213			X		
TG-213	TRI	THY	VII	PT-2**	
D214	REC	SIA	XI		
D214A	REC	SIA	XI		
D214B	REC		XI		
P214			X		
P214A			X		
P214B			X		
D215	REC	SIA	XI		
D215A	REC	SIA	XI		
D215B	REC	SIA	XI		

GROUP I, NUMERICAL

TYPE NUMBER	KIND	TYPE	TABLE NO.	SIMILAR TYPES	COST SPEC. NO.
P215			X		
P216			X		
P216A			X		
D217	REC	SIA	XI		
P217			X		
P217A			X		
P217B			X		
D218	REC	SIA	XI		
D219A	REC	SIA	XI		
D220	REC	SIA	XI		
D220A	REC	SIA	XI		
D220B	REC	SIA	XI		
SK-220			XXII		
D221	REC	SIA	XI		
D222	REC	SIA	XI		
D223	REC	SIA	XI		
D223A	REC	SIA	XI		
D223B	REC	SIA	XI		
D224	REC	SIA	XI		
D224A	REC	SIA	XI		
D224B	REC	SIA	XI		
D225	REC	SIA	XI		
D226	REC	SIA	XI		
D226A	REC	SIA	XI		
D226D	SIA		XI		
D226G	SIA		XI		
D226V	SIA		XI		
D226YE	SIA		XI		
SG226	DIO	SIN	V		
D227-A	SWI	SIA	XI-A		
D227-B	SWI	SIA	XI-A		
D227-D	SWI	SIA	XI-A		
D227-G	SWI	SIA	XI-A		
D227-I	SWI	SIA	XI-A		
D227-V	SWI	SIA	XI-A		
D227YE	SWI	SIA	XI-A		
D227-ZH	SWI	SIA	XI-A		
SG227	DIO	SIN	V		
D228-A	SWI	SIA	XI-A		
D228-B	SWI	SIA	XI-A		
D228-D	SWI	SIA	XI-A		
D228-G	SWI	SIA	XI-A		
D228-I	SWI	SIA	XI-A		
D228-V	SWI	SIA	XI-A		
D228YE	SWI	SIA	XI-A		
D228-ZH	SWI	SIA	XI-A		
D229A	SIA		XI		
D229B	SIA		XI		
D230A	SIA		XI		
D230B	SIA		XI		
VO-230	DIO	SIN	IV		
D231	REC	SIA	XI		
D231A	REC	SIA	XI		
D231B	REC	SIA	XI		
D232	REC	SIA	XI		
D232A	REC	SIA	XI		
D232B	REC	SIA	XI		
D233(P1)	SIA		XI		
D233A	REC	SIA	XI		
D233B	REC	SIA	XI		
D234B	REC	SIA	XI		
D235A	CON	SI	XI-C		
D235B	CON	SI	XI-C		
D235G	CON	SI	XI-C		
D235V	CON	SI	XI-C		
TG-235	TRI	THY	VII	PT-3**	
VG-236	DIO	SIN	IV		
VG-237	DIO	SIN	IV		
D238A	CON	SI	XI-C		
D238B	CON	SI	XI-C		

GROUP I, NUMERICAL					
TYPE NUMBER	KIND	TYPE	TABLE NO.	SIMILAR TYPES	COST SPEC. NO.
02380	CON	SI	XI-C		
0238G	CON	SI	XI-C		
D238V	CON	SI	XI-C		
0238YE	CON	SI	XI-C		
VO-239	OIO	SIN	IV		
UB-240	TRI	SIN	II	2S2+	
SB241	*PNO	SIN		2K1*, 2K1M+, S0241*	
S0241	*PNO	SIN		2K1*, 2K1M+, S0241*	
0242	REC	XI			
D242A	REC	XI			
0242B	REC	XI			
SB-242	PTG	SIN		2A1+	
S0-242	PTG	SIN	II	SB242, 2A1, 2A1M	
0243	REC	XI			
0243A	REC	XI			
0243B	REC	XI			
SB243	*TRI	DUO		2N1*, 2N1M*, S0243*	
S0-243	*TRI	TWM	II	2N1+	
0244	REC	XI			
0244A	REC	XI			
0244B	REC	XI			
SB244	*BEA	SIN		2P1+, S0244+	
S0-244	PND	SIN	II	2P1+	
D245	REC	XI			
0245A	REC	XI			
0245B	REC	XI			
SB245	*PNO	SIN		2ZH1M+	
0246	REC	XI			
D246B	REC	XI			
0247	REC	XI			
D247B	REC	XI			
LO-247	OS	VIII			
0248B	REC	XI			
LO-248	OS	VIII			
LO-249	OS	VIII			
GKO-250	TRI	SIN		GK-1A+	
VG-252	DIO	SIN	IV		
G256	TRI	SIN	III		
S0257	*PND	SIN	II	2ZH4+	
SB258	*BEA	SIN		2P3+, 2P2M+, S0258+	
S0-258	*PND	SIN	II	2P3+	
SB259	*TRI	OIO		4N1+	
S0259	*TRI	OIO		4N1+	
RB-280		XXII			
G-300	TRI	SIN		G68	
GI-300	TRI	SIN		GI-18B+	
GK-300	TRI	SIN		GU-8+	
GKE300	TET	SIN	III		
IFB300		XX			
SG301S	DIO	SIN	V		9103-59
2T301		X			
2T301A		X			
2T301B		X			
2T301D		X			
2T301G		X			
2T301V		X			
2T301YE		X			
2T301ZH		X			
3I-301A	TUN	GAS	XI-B		
3I-301B	TUN	GAS	XI-B		
3I-301G	TUN	GAS	XI-B		
3I-301V	TUN	GAS	XI-B		
D302	REC	XI			
P302		X			
SG302S	OIO	SIN	V		9103-59
1I-302A	TUN	GAS	XI-B		
1I-302B	TUN	GAS	XI-B		
1I-302G	TUN	GAS	XI-B		
1I-302V	TUN	GAS	XI-B		
D303	REC	XI			

GROUP I, NUMERICAL					
TYPE NUMBER	KIND	TYPE	TABLE NO.	SIMILAR TYPES	COST SPEC. NO.
P303			X		
P303A			X		
SG303S	OIO	SIN	V		9103-59
1T303A			X		
1T303B			X		
1T3030			X		
1T303G			X		
1T303V			X		
1T303YE			X		
0304	REC	XI			
P304			X		
SG304S	OIO	SIN	V		
0305	REC	XI			
SG305K	REG	V			
P306			X		
P306A			X		
SG306K	REG	V			
P307			X		
P308			X		
1T308A			X		
1T308B			X		
1T308G			X		
1T308V			X		
GT309A			X		
GT309B			X		
GT309D			X		
GT309G			X		
GT309V			X		
GT309YE			X		
0310	GEA	XI			
GT310A			X		
GT310B			X		
GT310D			X		
GT310G			X		
GT310V			X		
GT310YE			X		
P314A			X		
P314B			X		
P314C			X		
P322			X		
TGI-325/16	TRI	THY		MTI-5+, TGI-1-325/16+	
I-1-350/0.8	TRI	THY	IV		
R-350			XXII		
RB-350			XXII		
VO-360	DIO	SIN	IV		
G0-400	TRI	SIN		GS-6+	
M400	TRI	SIN	III		
TG-400/15	TRI	THY		TRI-130/15+	
TGI400/3.5	TRI	THY		TGI-2-400/3.5+	
0401	MOD	XIV			
KTS401A	REC	XI			
KTS401B	REC	XI			
LI-401		VIII			
M401	TRI	SIN	III		
P401		X		2N112S	
P402		X		SB-100S	
D403A	MIX	XIV			
D403B	MIX	XIV			
D403V	MIX	XIV			
P403		X		OC614=	
P403A		X		OC614=	
1T403A		X			
1T403B		X			
1T4030		X			
1T403G		X			
1T403I		X			
1T403V		X			
1T403YE		X			
1T403ZH		X			
P404		X			

GROUP I, NUMERICAL					
TYPE NUMBER	KIND	TYPE	TABLE NO.	SIMILAR TYPES	GOST SPEC. NO.
P404A			X		
D405	DET		XIV		
D405A	DET		XIV		
D405AP	DET		XIV		
D405B	DET		XIV		
D405BP	DET		XIV		
P405			X		
P405A			X		
P406			X	GT-60=	
P407			X		
P408			X		
P409			X		
T-409	DIO	IGM	IV		
G410	TRI	SIN	III		
P410			X		
P410A			X		
T-410	DIO	IGM	IV		
410R	KLY		IX		
G411	PND	SIN	III	KZH1**	
P411			X	AF114=	
P411A			X	AF114=	
T-411	DID	IGM	IV		
G412	PND	SIN	III		
G413	PND	SIN	III	GZH2**	
G414	PND	SIN	III		
P414			X		
P414A			X		
P414B			X		
P415			X		
P415A			X		
P415B			X		
P416			X		
P416A			X		
P416B			X		
P416V			X		
G417	TRI	SIN	III		
P417			X		
P417A			X		
G418	PND	SIN	III		
P418			X		
P418A			X		
P418B			X		
P418V			X		
P420			X		
P421			X		
G422	PND	SIN	III		
P422			X		
P422A			X		
P423			X		
P423A			X		
G424	PND	SIN	III		
G425	PND	SIN	III		
G430	TRI	SIN	III		
RB-430			XXII		
G431	TRI	SIN	III	G431A+	
G431A	TRI	SIN	III	G431	
G-431R	TRI	SIN		GS-4D+	
G433	TRI	SIN	III	G433A+	
G433A	TRI	SIN	III	G433	
M435	TRI	SIN	III		
G441	TRI	SIN	III		
G-450	TRI	SIN	III		
DS450	*PND	SIN		GU80, P800**	
R-450			XXII		
M-451	TRI	SIN		GM-51A+	
G-452	TRI	SIN	III	G-431A+	
G-454	TRI	SIN	III	GS-3B+	
M457	*TRI	SIN	II	MS3**+, UB180=, GM57+	
M-470	TRI	SIN		GM-70+	
G471	*PND	SIN		GK71+	

GROUP I, NUMERICAL					
TYPE NUMBER	KIND	TYPE	TABLE NO.	SIMILAR TYPES	GOST SPEC. NO.
G472		TRI	SIN	III	
G480	*TRI	SIN		GI-17**	
G-483	TET	SIN		GMI-83+	
G484	TRI	SIN	III		
G-489	*TET	SIN		GMI-89+	
G-490	*TET	SIN		GMI-90**	
IFK500			XX		
IFP500			XX		
ISSH500			XX		
VGV500	POW		XII		
P501			X		
P501A			X		
P502			X		
P502A			X		
P502B			X		
P502V			X		
2D503A	SI		XI		
2D503B	SI		XI		
P503			X		
P503A			X		
P504			X		
P504A			X		
P505			X		
P505A			X		
M600	*TRI	SIN		GM60+	
P601			X		
P601A			X		
P601B			X		
D602A	VID		XIV		
D602B	VID		XIV		
D602V	DET		XIV		
P602			X		
P602A			X		
D603	VIO		XIV		
P604			X		
P604A			X		
P604B			X		
P605			X		
P605A			X		
P606			X		
P606A			X		
P607			X		
P607A			X		
P608			X		
P608A			X		
P609			X		
P609A			X		
700AD	MAG		IX		
P701			X		
P701A			X		
P702			X		
P702A			X		
706AU	MAG		IX		
707A/B	KLY		IX		
LO-709A	OS		VIII		
714AU	MAG		IX		
LK-715	*TV			18LK15+	
720AYE	MAG		IX		
723A/B	KLY		IX		
725A	MAG		IX		
LK-726	TV			18LK3B+	
726	KLY		IX		
LO-729	*OS			8LO29+, 3BP1AS	
LO-730	OS			8LD30+	
LO-731	OS			13LM31+	
LO-732	OS			31LM32+	
LD-733	*OS			31LO33+	
LO-734	OS			23LM34+	
LD-735	OS			18LM35+	
LO-736	*OS			13LO36+	

GROUP I, NUMERICAL					
TYPE NUMBER	KIND	TYPE	TABLE NO.	SIMILAR TYPES	GOST SPEC. NO.
LO-737	*OS			13L037+	
LO-738	*OS			5L038+, 2AP1\$	
LO-739	OS			8L039+	
LK-740	*TV			18L04DB+, 7JP4\$	
LO-743	*OD			1DL043+	
LO-747	*OD			18L047+	
LO-748	*OD			13L048+	
LO-749	*OS			13L049+	
GK750	TRI SIN	III			7709-55
LO751	OS			23L051+	
LO-754	*OS			13L054+	
P800	*PMD	SIN		GU8D**+, 0545D=	
M800	TRI SIN	III			
G807	BEA SIN	III		807\$	838D-57
D808	REG	XIII			
D8D9	REG	XIII			
D810	REG	XIII			
D811	REG	XIII		811-A\$	
G811	TRI SIN	III			
D813	REG	XIII			
G-813	BEA SIN			GU-13+, 813\$	
D814-A	REG SI	XIII			
D814-B	REG SI	XIII			
D814-D	REG SI	XIII			
D814-G	REG SI	XIII			
D814-V	REG SI	XIII			
D815A(P)	REG SI	XIII			
D815B(P)	REG SI	XIII			
D815D(P)	REG SI	XIII			
D815G(P)	REG SI	XIII			
D815V(P)	REG SI	XIII			
D815YE(P)	REG SI	XIII			
D815ZH(P)	REG SI	XIII			
D816A(P)	REG SI	XIII			
D816B(P)	REG SI	XIII			
D816D(P)	REG SI	XIII			
D816G(P)	REG SI	XIII			
D816V(P)	REG SI	XIII			
D817A(P)	REG SI	XIII			
D817B(P)	REG SI	XIII			
D817G(P)	REG SI	XIII			
D817V(P)	REG SI	XIII			
D818A	REG SI	XIII			
D818B	REG SI	XIII			
D818D	REG SI	XIII			
D818G	REG SI	XIII			
D818V	REG SI	XIII			
D818YE	REG SI	XIII			
G-827	TET SIN			GU-27B+, 827R\$	
G-829	TET TWN			GU-29+, 829-B\$	
G-832	BEA TWN			GU-32+, 832A\$	
G837	*PND SIN	III		0512/500=, 837\$	
G-880	TRI TWN			GU-12A+, 880\$	
G889	TRI SIN	III		889-A\$	
TG-884	TRI THY			TG1-D.1/D.3+, 884*	
G891	TRI SIN	III		891\$	
D901A	VAR SI	XI-D			
D901B	VAR SI	XI-D			
D901D	VAR SI	XI-D			
D901G	VAR SI	XI-D			
D901V	VAR SI	XI-D			
D901YE	VAR SI	XI-D			
2S920A(P)	REG SI	XIII			
2S930A(P)	REG SI	XIII			
2S950A(P)	REG SI	XIII			
2S980A(P)	REG SI	XIII			
GD1000	TRI SIN			G-29+	
GKE1000	TET SIN	III			
M-1000	TRI SIN			GM-100+	
VG1000	POW	XII			

GROUP I, NUMERICAL					
TYPE NUMBER	KIND	TYPE	TABLE NO.	SIMILAR TYPES	GOST SPEC. NO.
VKV1000	POW	XII			
D1001	REC	XI			
D1001A	REC	XI			
D1002	REC	XI			
D1DD2A	REC	XI			
D1003A	REC	XI			
D1004	SIA	XI			
D1D05A	SIA	XI			
D1005B	SIA	XI			
D1006	SIA	XI			
D1007	SIA	XI			
D1008	SIA	XI			
D1009	SIA	XI			
D1D09A	SIA	XI			
D1010	SIA	XI			
D1010A	SIA	XI			
D1011A	SIA	XI			
TG1D50	TRI THY			TG2-0.1/0.1+	
IFP1500		XX			
1502	DIO SIN	IV		5TS9S	
1504	TRI SIN	II			
1506	BEA TWN	II			
1509	BEA TWN	II			
1511	PND SIN	II			
1512	PND SIN	II			
1514	PND SIN	II			
1515	BEA SIN	II		6KH2P+, EAA91=, 6AL5\$	
1536	DIO TWN	II			
1538	BEA SIN	II			
1539	TRI SIN	II			
1540	BEA SIN	II			
1550	DWD SIN	II			
D1602A	REC	XI			
D1602B	REC	XI			
D1602V	REC	XI			
G1625	BEA SIN	III		1625\$	
GK200D	TRI SIN	III			
IFK2000		XX			
TG2050	TET THY			TG1-0.1/I.3+, 2050\$	
GK3000	TRI SIN	III			771D-55
M-3000	TRI SIN			GMI-1B+	
PI-300D	*PND SIN			GI-8*+	
GI-3100	TRI SIN	III			
IFP4000		XX			
4671	*TRI SIN			6S1ZH+	
G-5000	TRI TWN			GS-3B+	
IFP15000		XX			
IFK20000		XX			
G40011	TRI SIN	III			
IFK80000		XX			

GROUP II, RECEIVING

TYPE NUMBER	KIND	TYPE	BULB	USE	CATHODE	E _f V	I _f mA	MAXIMUM			TYPICAL						CAPACITY		BASE	
								E _b V	I _b mA	P _p W	E _b V	E _{q2} V	E _{q1} V	I _b mA	I _{q2} mA	S _m mmho	μ	R _p Ω		IN pF
06P2B	PND	SIN	T3F	AF	F	0.6	30	35	350U	0.1	30	30	0	90U	0.1	.1	1M	5.0	3.0	5CL
06ZH6B	PND	SIN	T3F	AF	F	0.6	20	35	350U	8M	30	30	0	150U	0.1	.1	900K	7.0	7.0	5CL
1A1P	PTG	SIN	T6		F	1.2	60	100		0.3	90	45	0	/1	.3	500K	5.1	6.3	7AT	
1A2P	PTG	SIN	T6		F	1.2	30	90		0.3	90	45	0	/1	.2	1M	2.2	2.4	7AT	
1B1P	PND	DIO	T6		F	1.2	60	100		4	0.2	67	0	2	.6	1M	1.8	2.1	6AU	
1B2P	PND	DIO	T6		F	1.2	30	90		2	0.1	60	45	0	.5	1M	3.5		6AU	
1E1P	TET	SIN	T5	EL	F	1.0	46				6	4	3	100U	0.4	/1	3.5		TE2	
1E3P	TRI	SIN			F	1.3	24				8		3	300U		/1	3.5			
1I2P	TRI	PND			F	1.2	60	90		2	0.2	60		1	.1	25K	0.7	3.0	PT1	
1I2P	PND	TRI			F	1.2	60	90		2	0.2	60	45	1	.2	650K	3.5	4.7	PT1	
1K1P	PND	SIN	T6		F	1.2	60	100			0.6	90	67	3	1.2	1M	3.5	7.5	6AR	
1K2P	PND	SIN	T6		F	1.2	30	90		3	0.3	60	45	1	0.3	1M	3.0	4.9	6AR	
1N3S	TRI	DUO	T10		F	1.2	120	150			1.0	120		/3	.8	14K			7AB	
1P2B	PND	SIN	T3F	AF	F	1.3	50	50		8M	45	45	2	1	0.5	50K	3.0	6.0	5CL	
1P3B	PND	SIN	T3F	AF	F	1.3	28	50		5M	45	45	2	1	0.3	50K	3.0	6.0	5CL	
1P4B	PND	SIN	T3F	AF	F	1.3	20	50		/2	4M	45	2	1	0.3	200K	3.0	6.0	5CL	
1P5B	PND	SIN	T3B		F	1.2	120	150		10		90	/5	12	1.0	1.9	3.9	2.6	100	
1P228B	PND	SIN	T3B		F	1.2	115	400		400		90	/5	13	1.0	1.9	6.9	4.7	100	
1P24B	PND	SIN	T3B		F	1.2	12					150	125	10	1.2	2.7	7.3	4.0		
1P248B	PND	SIN	T3B		F	1.2	255	400		800	2.5	150	125	14	3.0	2.8	7.1	4.0	60	
1P328B	PND	SIN	T3B		F	1.2	215	200		20	3.0	150	150	14	1.5	2.3	6.3	5.8	60	
1S12P	TRI	SIN			F	1.2	30	90		/3	0.2	60	1	1	.9	16	0.8	0.7	300	
1TS1S	DIO	SIN	T10		F	0.7	185	15K		5			/1			19K	2.0		TS1	
1TS7S	DIO	SIN	T10		F	1.3	200	30K		1.7			2						8HC	
1TS11P	DIO	SIN	T6		F	1.2	200	20K		2			300U				1.5		8HC	
1TS21P	DIO	SIN	T7		H	1.4	690	25K		40			/1						DS5	
1ZH1ZH	PND	SIN	ACO		F	1.2	50	145				135	68	3	0.4	.6	800K	1.8	2.5	
1ZH2M	PND	SIN			F	1.2	30					70	70	0	1	0.6				
1ZH17B	PND	SIN	T3B		F	1.2	60	90		5	0.5	60	45	0	2	0.1	1.4	25K	3.7	2.7
1ZH18B	PND	SIN	T3B		F	1.2	21	90		3	0.3	60	45	0	1	0.2	.8	60K	3.7	2.7
1ZH24B	PND	SIN	T3B		F	1.2	12					60	45	0	1	0.2	.8	40K	3.6	2.4
1ZH29B	PND	SIN	T3B		F	1.2	60					60	45	0	5	0.2	2.0	35K	4.9	3.3
1ZH30B	PND	SIN	T3		F	1.2	15	20		1		12	12	0	1	.8	13K	8.5	3.5	
1ZH36B	PND	SIN	T3B		F	1.3	75	200				150	45	1	3	0.4	1.5	4.2	3.0	
GU-2	BEA	SIN	S18		H	6.3	900	750		120	30.0	250	250			10.0				

GROUP II, RECEIVING

TYPE NUMBER	KIND	TYPE	BULB	USE	CATHODE	E _f V	I _f mA	MAXIMUM				TYPICAL						CAPACITY		f _{max} MHz	BASE
								E _b V	I _b mA	P _p W	E _b V	E _{g2} V	E _{g1} V	I _b mA	I _{g2} mA	S _m mmho	μ	R _p Ω	IN pF		
2A1	PTG	SIN		CN	H	2.0	160	160		0.7	120	70	4	2			150K	9.6	11.4	8A	
2D1L	DWD	SIN	F10		H	2.2	130				50		2							DW3	
2D1S	DIO	SIN	LIT		H	2.3	400	100		/0.1			1000							3G	
2D2S	DIO	SIN	F10		F	1.5	1500	200		40	5.0		5					2.4		3G	
2D3B	DIO	SIN	T3F		F	2.2	110			150											
2D3S	DIO	SIN																			
2D7S	DIO	SIN	T6		W	1.4	2	300					3								
2D9S	DIO	SIN	T10		F	3.7	550	500		1											
2E1	TET	SIN			F	2.0	110	160					0	1	0.5		1M	9.0	9.0	TE5	
2E2	* TET	SIN			F	1.8	320						2	7	4.0	300K	8.3	9.0	TE6		
2E2P	TET	DUO	T8	EL	F	2.0	55						3	45U	0.7		4.0			TE3	
2K1	PND				F	2.0	120	120					1	/4	1.2	750K					
2K1M	* PND	SIN			F	2.0	120						3	1.1	1.4	1M				5Y	
2K2M	PND	SIN	T9		F	2.0	60	160					2	0.5	.9	1M	5.4	8.1		5Y	
2KH1L	DWD	SIN			H	2.2	130			50			2				2.2				
2N1	TRI	DUO			F	2.0	240	160					0	3			32	2.8	5.7	7AB	
2P1	BEA	SIN			F	2.0	185						2	4	0.7	150K				6X	
2P1P	BEA	SIN	T5		F	1.2	120	90		15			4	10	2.2	100K	5.5	4.0		7AV	
2P2	* BEA	SIN			F	2.0	220						4	10	1.8	90K					
2P2P	BEA	SIN	T5		F	1.2	60	90		7			4	3	0.8	170K	3.7	3.8		7BA	
2P3	BEA	SIN			F	2.0	230						6	10	1.7	80K				6X	
2P5B	PND	SIN	T3B		F	1.2	180	400		800			4	18	.1		7.1	4.7	100		
2P9M	BEA	SIN	T10		F	2.0	1000	300					5	35	1.5	40K	8.5	8.5		6X	
2P19B	PND	SIN	T3B		F	2.2	70	200		15			5	8	3.5	50K	4.5	7.0		PS6	
2P29L	PND	SIN	T9		F	2.2	120	200		20			6	10	2.0	50K	4.3	5.5		PS2	
2P29P	PND	SIN	T5		F	2.2	110	200		5			0	/2	0.4	100K	4.9	2.0	120	PS8	
2S1	TRI	SIN			F	2.0	110	120					0	/6		14	3.6	3.0			
2S2	TRI	SIN	T8		F	2.0	120	160					1	1.3		22	2.8	2.7		5S	
2S4S	TRI	SIN		PA	F	2.5	2500	360		15.0	250	45		62		4	800K	7.5	5.5	4D	
2S14B	TRI	SIN	T3F		F	2.2	60	250		5			3	/4		15	8400	2.8	2.1	300	TS2
2TS2S	DIO	SIN	S12		H	2.5	1750	12K		100			7							4AC	
2VD8	DIO	SIN			F	2.5	1750	12K		100											
2ZH1M	* PND	SIN			F	2.0	320						2	7	1.5	1M				PS8	
2ZH2M	PND	SIN	T9		F	2.0	60	160					/1	2	0.5		5.4	8.1		5Y	
2ZH4	* PND	SIN			F	2.0	275			1.2	200	100	7	14	2.4	110K				PS8	

GROUP II, RECEIVING

TYPE NUMBER	KIND	TYPE	BULB	USE	CATHODE	E _f V	I _f mA	MAXIMUM				TYPICAL							CAPACITY		BASE	
								E _b V	I _b mA	P _p W	E _b V	E _{g2} V	E _{g1} V	I _b mA	I _{g2} mA	S _m mmho	μ	R _p Ω	IN pF	OUT pF		f _{max} MHz
2ZH14B	PND	SIN	T3B		F	2.2	30	90	5	0.5	90	45	0	2	0.8	1.2			4.5	6.0	PS6	
2ZH15B	PND	SIN	T3B		F	2.2	14	90	3	0.2	60	45	0	1	0.1	7.0			4.0	5.0	P4S	
2ZH27L	PND	SIN	F10		F	2.2	57	200	5	1.0	120	45	0	2	0.5	1.2			5.3	4.9	PS3	
2ZH27P	PND	SIN	T5		F	2.2	57	120	5	1.0	120	45	0	1	0.5	1.0			4.5	2.0	PS4	
2ZH28L	PND	SIN			F	2.2	28			1.0	120	45	0	2	0.5	1.2			5.4	4.8	PS3	
EM-3	TET	SIN	T16		F	3.0	120				6	4	3	70U	0.4	0.1			5.0			
GU-3	BEA	SIN	S18		H	12.6	450	750	120	30.0	250	250			2.2	10.0					60	
3A4S	PND	SIN			F	3.2	100				150	90	0	13	2.2	1.9				700K	P7S	
3B4S	BEA	SIN	T5		F	3.2	150				180	150	20	30	2.5	2.4					P8S	
3S1	TRI	SIN			F	2.5	1A				220		4	8	2.2	2.2				10K		
3S2	TRI	SIN			F	2.5	1A				220		10	15	2.4	2.4			5.0	2.5	4F	
3S9	TRI	SIN			F	2.5	1000			6.0	220		10	17	2.4	11					4AC	
3TS16S	DIO	SIN			H	3.2	220	25K	80					1								
EM4	TRI	SIN	T6		F	1.3	24				8		3	300U		/	1	2	3.5			
4D5S	DIO	SIN	T4		H	4.0	240				10			5								
4E1	TET	SIN			F	4.0	75	200			2.0	160	80	0	3	.8	350		8.0	6.3	TE5	
4E2	TET	SIN			F	4.0	150	200			2.0	160	80	0	/8	1.8	400		10.5	8.0	TE5	
4E3	TET	SIN			H	4.0	1000	250			160	60	1	8	1.5	3.0			200K			
4F6S	BEA	SIN		PA	H	4.0	1100				10.0	250	16	34	6.0	2.5	200		6.5	4.5		
4N1	TRI	DUO			F	4.0	2A				6.0	120	0	30	3.2							
4P1	* PND	SIN				4.0	1A				240	140	11	22	6.0	2.1			8.5	9.4	100	
4P1L	PND	SIN	T10		F	4.2	325	250	50	7.5	200	150	20	50	10.0	6.0					PS2	
4P10S	PND	SIN				4.0	1750				315	210	7	63	1.4	8.5						
4S1	TRI	SIN			F	4.0	70				120		0	8	1.3	1.3						
4S2	TRI	SIN			F	4.0	70				160		0	4	1.3	1.3						
4S3	TRI	SIN			F	4.0	155	200			3.0	160	6	15	2.1	2.1			3.8	2.4		
4S3S	TRI	SIN			H	4.4	330				5.0	100	4	18	3.0	3.0			1.5	0.6	1K	
4S4	* TRI	SIN			F	4.0	1A				15.0	250	37	57	3.2	4					TS3	
4S5	TRI	SIN			H	4.0	1A				240		3	6	1.7	32						
4TS6S	DIO	SIN	T10		F	4.0	1750				1.0	50		7							DS4	
4TS14S	DIO	SIN	T11		F	4.0	1750	60	20	1.2	60			7							DS4	
4VD1	DIO	SIN			F	4.0	700				350			50								
4VKH1	DIO	TWN			F	4.0	2300	1K	560													
4VKH2	DIO	SIN			F	4.0	2000	/2K	1200													
4ZH1L	PND	SIN	F10		H	4.2	225	250	11	2.0	150	75	2	2	0.5	1.6			4.0	4.2	200	
																			1M	4.0	4.2	200

GROUP II, RECEIVING

TYPE NUMBER	KIND	TYPE	BULB	USE	CATHODE	E _f V	I _f mA	MAXIMUM			TYPICAL							CAPACITY			BASE
								E _b V	I _b mA	P _p W	E _b V	E _{q₂} V	E _{q₁} V	I _b mA	I _{q₂} mA	S _m mmho	μ	R _p Ω	IN pF	OUT pF	
4ZH1P	PND	SIN	F10	H	H	4.2	225	250	11	2.0	150	75	0	7	1.7	1.3	770K	14.0	4.5	DW1	
4ZH5	TET	SIN		H	H	4.0	1000	250			120	40	1	/3	3.5	2.0		11.0	4.5	DW4	
4ZH5S	PND	SIN		RF	H	4.0	1000				160	60		5						DW2	
5TS3S	DWD	SIN	S16	F	F	5.0	3000	/2K	750		500			230						DW2	
5TS4M	DIO	DUO	T11	H	H	5.0	2000	/2K	415		400			70						DS1	
5TS4S	DIO	DUO	T14	H	H	5.0	2000	1K	375		500			62						DW4	
5TS8S	DWD	SIN	T17	H	H	5.0	5000	/2K	1200	30.0	500			400						DW2	
5TS9S	DWD	SIN	F13	H	H	5.0	3000	/2K	600	12.0	500			190						DW2	
5TS9SE	DWD	SIN	F13	H	H	5.0	3000	/2K	600	12.0	500			190						DW2	
5TS12P	DIO	SIN	T7	H	H	5.0	770	5K	350	5.0	2K			50						DS1	
5VKH2	DWD	SIN			H	5.0	2000	14H	375												
5VKH3	DWD	SIN			H	5.0	3000	15H	675												
6A2P	PTG	SIN	T5	CN	H	6.3	300	330	14	1.1	250	100		3	1.0	.5	100K	7.0	8.6	7CH	
6A3P	GTB	SIN		H	H	6.3	300	150		1.2	75	75	4	/5	7.0	1.2		4.7	4.0	7DF	
6A7	PTG	SIN	M8	CN	H	6.3	300	300	15	1.1	250	100	0	4	8.5	.4	500K	9.5	12.0	8R	
6A8	PTG	SIN	S11	CN	H	6.3	300	330	15	1.0	250	100	0	4	2.7	.5	360K	12.5	12.5	8A	
6A10S	PTG	SIN	S11	CN	H	6.3	300	330	15	1.1	250	100	0	4	9.0	.4	1M	9.0	10.0	8R	
6B1P	DIO	PND		H	H	6.3	400				150			15				9.0	4.0		
6B1P	PND	DIO		H	H	6.3	400				250	250	2	26	2.7	29.0		9.0	4.0		
6B2P	PND	DIO	T5	RF	H	6.3	300			2.1	250	100	1	6	1.6	2.7	700K	4.2	4.1	PD4	
6B8S	PND	DWD	S12	RF	H	6.3	300	275		2.5	250	125	3	10	2.4	1.3	600K	4.0	9.0	8E	
6D3D	DIO	SIN	L1T	H	H	6.3	770	200	150					27						3G DS2	
6D4ZH	DIO	SIN	ACO	H	H	6.3	150	365	30		165			5				0.9		4G	
6D6A	DIO	SIN	T2F	H	H	6.3	150	450	70	0.2	165			8				3.0			
6D8D	DIO	SIN	PEN	H	H	6.3	450	450	180U	/0.1										5G	
6D10D	DIO			H	H	6.3	750		30		100			10							
6D13D	DIO	SIN	PEN	F	F	6.3	200	450			150									48H	
6D14P	DIO	SIN	T7	H	H	6.3	1100	750	600		20			175							
6D20P	DIO	SIN		H	H	6.3	1800	6K	600					220						9CB	
6E5P	TET	SIN	T6	H	H	6.3	600	150	70	8.3	150	150	2	45	14.0	27.0	8K	16.0	2.3	9BD	
6E6P-YE	BEA	SIN	T7	H	H	6.3	600	250	100	8.3	150	150	2	44	10.0	30.5	15K	15.0	2.7	TE1	
6F1P	TRI	PND	T7	H	H	6.3	430	250	14	1.5	100		2	13			4K	3.0	5.0	9CV	
6F1P	PND	TRI	T7	H	H	6.3	430	250	14	1.7	170	170	2	10	4.0	6.0	400K	0.5	3.4	9AE	
6F3P	TRI	PND	T7	H	H	6.3	850	250	15	1.0	170		1	2			75	2.2	0.4	9AE	
6F3P	PND	TRI	T7	H	H	6.3	850	275	60	8.0	170	170	11	41	14.0	.7	15K	9.3	8.5	PT5	

GROUP II, RECEIVING

TYPE NUMBER	KIND	TYPE	BULB	USE	CATHODE	E _f V	I _f mA	MAXIMUM			TYPICAL						CAPACITY		f _{max} MHz	BASE
								E _b V	I _b mA	P _p W	E _b V	E _{q₂} V	E _{q₁} V	I _b mA	I _{q₂} mA	S _m mmho	μ	R _p Ω		
6F4P	TRI	PND	T9		H	6.3	720	250	12	1.0	200	3	4.0	65	16K	4.0	0.6	PT4		
6F4P	PND	TRI	T9		H	6.3	720	250	40	4.5	170	18	7.0	100K	9.5	4.0	PT4			
6F5M	TRI	SIN	T10		H	6.3	300	350			250	1	2.0	100			5M			
6F5P	TRI	PND	T7		H	6.3	900			0.5	100	5	7.0	70	23K	3.5	0.3	PT6		
6F5P	PND	TRI	T7		H	6.3	900			9.0	185	41	2.7	7.5	11.7	8.8	PT6			
6F6S	PND	SIN		PA	H	6.3	700	375		11.0	250	34	6.5	2.5	7.5	11.0	7S			
6F7	TRI	PND	M11		H	6.3	300	110		0.5	100	3	.5	70			PT2			
6F7	PND	TRI	M11		H	6.3	300	275		2.2	250	7	1.6				PT2			
6G1	TRI	DWD	M10		H	6.3	300	275		2.7	250	9	1.9	16	8500	3.6	2.8	8Q		
6G2	TRI	DWD	M10		H	6.3	300	330		0.9	250	2	1	1.1	91K	3.2	3.0	8Q		
6G2P-K	TRI	DWD	T6		H	6.3	300			250	2	1	1.8	100			TT1			
6G3P	TRI	TRD			H	6.3	450	300		1.0	250	3	1	1.3	48K	2.0	1.2	TD3		
6G7	TRI	DWD			H	6.3	300	330		1.0	250	3	1	1.3	54K	5.0	3.8	9CA		
6I1P	TRI	PTG	T6		H	6.3	300	250	12	0.8	100	11	4.0	23	6K	2.6	2.0	9CA		
6I1P	PTG	TRI	T6		H	6.3	300	300	6	1.7	250	7	3.5	.8	1M	5.1	7.4	9CA		
6I14P	TRI	PTG	T6		H	6.3	300	250	12	0.8	100	11	4.0	23	6K	2.6	2.0	9CA		
6I14P	PTG	TRI	T6		H	6.3	300	300	6	1.7	250	7	3.5	.8	1M	5.1	7.4	9CA		
6K1B	PND	SIN	T3F		H	6.3	200	150	15	1.2	120	11	4.0	4.8	200K	4.8	3.8	PS1		
6K1L	PND	SIN	T9		H	6.3	150			1.0	150	75	2	3	700K	3.8	4.2	7CM		
6K1P	PND	SIN	T5		H	6.3	150	275		1.8	250	100	3	6	400K	3.4	3.0			
6K1ZH	PND	SIN	ACO		H	6.3	150	275		1.8	250	100	3	7	400K	3.0	3.0			
6K3	PND	SIN	M8		H	6.3	300	330		4.4	250	100	3	9	800K	6.0	7.0	8N		
6K4	PND	SIN	M8		H	6.3	300	330		3.3	250	125	1	12	900K	8.5	7.0	8BK		
6K4P	PND	SIN	T6		H	6.3	300	300	20	3.0	250	100	1	11	800K	6.5	5.5	7BD		
6K6A	PND	SIN	T2B		H	6.3	127	150	15	1.3	120	100	9	4.0	2.8	2.5				
6K7	PND	SIN	M10		H	6.3	300	330		3.0	250	100	3	7	830K	7.0	12.0	7R		
6K9S	PND	SIN	M10		H	6.3	300	330		4.4	250	100	3	9	800K	4.8	11.0	7R		
6K11B-K	PND	SIN	T3B		H	6.3	200	150	15	1.2	120	120	8	4.0	3.9	2.8				
6K13P	PND	SIN	T7		H	6.3	300			200	90	12	4.5	12.5	500K	11.7	3.9	P20		
6KH2P	DIO	TWN	T9		H	6.3	300	450	90	0.5	150	10			3.8		6BT			
6KH6B	DIO	TWN			H	6.3	300	100	4								DW9			
6KH6S	DIO	TWN			H	6.3	300	465	50		165	9			4.0		8AN			
6KH7B	DIO	TWN	T3B		H	6.3	300	450	10	0.2	165	8			5.8		DW5			
6L7	PTG	SIN	M11	MX	H	6.3	300	330		1.5	250	100	3	5	1M	7.5	11.0	7T		
6N1P	TRI	TWN	T6		H	6.3	600	300	25	2.2	250	4			11K	3.1	1.8	9AJ		

GROUP II, RECEIVING

TYPE NUMBER	KIND	TYPE	BULB	USE	CATHODE	E _r V	I _r mA	MAXIMUM				TYPICAL						CAPACITY		f _{max} MHz	BASE
								E _b V	I _b mA	P _p W	E _b V	E _{o2} V	E _{o1} V	I _b mA	I _{o2} mA	S _m mmho	μ	R _p Ω	IN pF		
6N2P	TRI	TWN	T6		H	6.3	340	300	10	1.0	250	1	2	2.1	98	47K	2.4	3.0	9AJ		
6N3P	TRI	TWN	T6		H	6.3	350	300	18	1.5	150	2	8	4.9	37	6K	2.7	1.4	8CJ		
6N4P	TRI	TWN	T6		H	6.3	300	300	10	1.5	250	4	3	1.7	41	23K	1.5	1.6	9AJ		
6N5P	TRI	TWN	T6		H	6.3	600	200	25	2.2	200	5	8	4.2	27	6500	3.0	1.7	9AJ		
6N5S	TRI	TWN	S16	PA	H	6.3	2500	250	125	13.0	90	30	60	4.5	3	460	9.5	5.0	8BD		
6N6P	TRI	TWN	T7		H	6.3	600	300	45	4.8	120	2	30	10.5	20	1800	4.4	1.9	9AJ		
6N7	TRI	TWN	M9		H	6.3	800	300		1.0	250		7	2.0	32	16K					
6N7S	TRI	DUO	T9		H	6.3	810	300		6.0	300	6	/4	1.6	35	2200	1.6	3.2	8B		
6N8S	TRI	TWN	T8		H	6.3	600	330	20	2.7	250	8	9	2.6	20	8K	2.8	3.8	8BD		
6N9S	TRI	TWN	T8		H	6.3	300	275		1.1	250	2	2	1.6	70	44K	3.0	2.8	8BD		
6N10S	TRI	DUO	T11		H	6.3	300	275		11.0	250	2	2	1.3	70	54K	1.4	0.2	8S		
6N12S	TRI	TWN	T11		H	6.3	900	300		4.2	180	7	23	6.4	17	2700			8BD		
6N13S	TRI	TWN	S16		H	6.3	2500	250	130	13.0	90	30	80	5.0	2	460	7.0	9.0	8BD		
6N14P	TRI	TWN	T5		H	6.3	350	180		1.5	90	1	10	6.8	25	3200	4.9	2.9	9DD		
6N15	* TRI	TWN			H	6.3	450				100		9	5.6	38						
6N15P	TRI	DUO	T5		H	6.3	450	300		1.6	100	/1	9	5.6	38	6800	2.0	1.4	7BF		
6N16B	TRI	TWN	T3B		H	6.3	400	200	14	0.9	100	2	6	5.0	25	5K	2.5	1.6	TD1		
6N17B	TRI	TWN	T3B		H	6.3	400	250	10	0.9	200	1	3	3.8	75	20K	2.8	1.5	TD1		
6N18B	TRI	TWN	T3B		H	6.3	330	200	14	0.9	100	6	6	5.0	25	325K	2.6	1.5	TD1		
6N19P	TTR	DWD	T7		H	6.3	650	250	50	2.0	150		14	13.5		25K	3.8	1.2			
6N23P	TRI	TWN	T7		H	6.3	300	300	20	1.8	120		15	12.7	32		3.6	2.1	9AJ		
6N24P	TRI	TWN	T7		H	6.3	300				90	9	15	12.5	33		6.3	3.2	9DD		
6P1P	BEA	SIN	T7		H	6.3	500	250	70	12.0	250	250	12	4.9		50K	7.8	5.7	PS9		
6P2P	PND	SIN			H	6.3	450			120	120	5	35	8.0					6CC		
6P3S	BEA	SIN	T14		H	6.3	900	400	90	20.0	250	250	14	72	8.0	22K	11.0	8.2	7S		
6P4	PND	SIN			H	6.3	300			180	180	9	15	2.3			5.5	7.0			
6P6B	PND	SIN			H	6.3	700	375		250	250	16	34	6.5			6.0	12.0	7S		
6P6S	BEA	SIN	T9	PA	H	6.3	450	350	100	13.2	250	250	12	4.5		52K	9.5	9.5	7S		
6P7S	BEA	SIN	T16		H	6.3	900	6K	100	20.0	250	250	14	72	8.0	32K	11.5	6.0	5BT		
6P8S	PND	SIN	T11		H	6.3	300			180	180	9	15	2.4					7S		
6P9	BEA	SIN	M10	PA	H	6.3	650	330		9.0	300	150	3	6.5		80K	13.0	7.5	8Y		
6P9E	BEA	SIN	M10	PA	H	6.3	560	330		9.0	300	150	3	5.8		100K			8Y		
6P13S	BEA	SIN	T10		H	6.3	1300	450	130	14.0	200	200	19	60		25K	14.0	18.0	5BT		
6P14P	BEA	SIN	T6		H	6.3	760	300	66	12.0	250	250	6	48		20K	11.0	7.0	9CV		
6P15P	BEA	SIN	T6		H	6.3	760	330	90	12.0	300	150	2	30		100K	14.0	7.0	P1S		

GROUP II, RECEIVING

TYPE NUMBER	KIND	TYPE	BULB	USE	CATHODE	E _f V	I _f mA	MAXIMUM			TYPICAL							CAPACITY		f _{max} MHz	BASE
								E _b V	I _b mA	P _p W	E _b V	E _{q2} V	E _{q1} V	I _b mA	I _{q2} mA	S _m mmho	μ	R _p Ω	IN pF		
6P17S	BEA	SIN			H	6.3	900	500		20.0	250	14	72	8.0	5.9	32K	11.5	6.0	9CV		
6P18P	BEA	SIN	T6		H	6.3	760	250	75	12.0	170	6	53	8.0	11.0	23K	11.5	6.0	5BT		
6P20S	BEA	SIN	T16		H	6.3	2500	700	200	23.0	175	30	90	6.0	8.5		24.0	10.0	P14		
6P21S	BEA	SIN			F	6.3	750	600	100	18.0	600	16	36	5.0	4.0	20K	8.2	6.5			
6P25B	PND	SIN	T3		H	6.3	450	170		4.1	110	8	30	5.0	4.2		7.5	8.5			
6P31S	BEA	SIN	T11		H	6.3	1300	300		10.0	100	9	80	8.5	12.5		18.0	8.5	PS7		
6P36S	BEA	SIN	T13		H	6.3	2000			100	100	7	120	20.0		4500	36.0	21.0	P21		
6S1P	TRI	SIN	T5	RF	H	6.3	150	275	1.8	250	7	6	2.2	2.2	26	11K	1.4	1.1	7BS		
6S1ZH	TRI	SIN	ACO		H	6.3	150	275	1.8	250	7	6	2.2	2.2	26	11K	1.0	0.6	T3S		
6S2B	TRI	SIN	M9		H	6.3	300	300	2.5	250		9	2.6	2.6	20	7K	3.4	3.6	6Q		
6S2P	TRI	SIN	T5		H	6.3	400	165	2.5	150	1	14	11.5	48	4200	5.3	4.2	7BQ			
6S2S	TRI	SIN	T9		H	6.3	300	330	2.0	2.7	250	8	9	2.5	20	8000	3.0	4.5	6Q		
6S3B	TRI	SIN	T3F		H	6.3	150	300	12	2.5	270		8	2.2	14	6400	2.5	3.9			
6S3P	TRI	SIN	T6		H	6.3	300	160	35	3.0	150	1	16	20.0	50	2600	6.5	1.5	TS4		
6S4B	TRI	SIN	M9		H	6.3	300	300	0.4	250		1	1	1.5	100	66K	2.0	12.0	5M		
6S4P	TRI	SIN	T6		H	6.3	300	160	35	3.0	150	1	16	20.0	50	2600	11.5	3.7	TS4		
6S4S	TRI	SIN	S16	PA	F	6.3	1000	360	15.0	250	45	60	5.4	4	840			5S			
6S5	TRI	SIN			H	6.3	300		1.2	250	8	8	2.2	20		3.0	11.0	6Q			
6S5D	TRI	SIN	LIT		H	6.3	770	300	25	6.5	250	/1	25	4.7	42	9K	2.3	0.5	3G		
6S5S	TRI	SIN	M9		H	6.3	300	350	2.7	250	6	8	2.2	20	9K	3.8	12.0	6Q			
6S6B	TRI	SIN	T3F		H	6.3	200	250	14	1.4	120	2	9	5.0	25	5K	3.3	3.5	500		
6S7B	TRI	SIN	T3F		H	6.3	200	300	7	1.4	250	2	/5	4.0	65	16K	3.3	3.4			
6S8S	TRI	SIN	T10		H	6.3	300	500	3.6	300	10	11	3.0	3.0	20	6700	2.2	0.6	TS5		
6S9D	TRI	SIN	LIT		H	6.3	570	300	25	5.5	250	1	15	10.0	100	10K	2.9	/0.1	900		
6S10D	TRI	SIN	LIT		H	6.3	920	5K	8500	9.0								3G			
6S11D	TRI	SIN	PEN		H	6.0	176	120	30	3.6	110	2	20	6.5	17	2500	2.5	0.1	18H		
6S13D	TRI	SIN	ROC		H	6.3	770	350	9.0	300	4	21	5.2	32	6200	2.7	/0.1	36H			
6S15P	TRI	SIN	T6		H	6.3	440	160	7.5	150		40	4.5	10.5	1.5				T2S		
6S16D	TRI	SIN	PEN		H	6.3	192	170	35	3.6	135	4	12	6.0	17	2800	2.5	0.1	18H		
6S17K	TRI	SIN	ROC		H	6.3	400	200	2.0	175	1	10	12.0	125	10K	3.5	/0.1				
6S18S	TRI	SIN	T20		H	6.3	6600	450	60.0	120	20	550	40.0	2	60				TS6		
6S19P	TRI	SIN	T7		H	6.3	1000	350	110	11.0	100	20	95	7.5	4	500	6.5	6.0	TS7		
6S20S	TRI	SIN	T13		H	6.3	200	25K	/2	25.0	25K	8	1	.2	2K	10M			TS8		
6S21D	TRI	SIN	PEN		H	6.3	176		3.6	110	2	20	6.5	16	2500	2.5	0.1				
6S25B	TRI	SIN	T3B		H	6.3	220	250	15	1.4	120		8	5.0	29	220K	3.3	3.5			

GROUP II, RECEIVING

TYPE NUMBER	KIND	TYPE	BULB	USE	CATHODE	E _r V	I _r mA	MAXIMUM				TYPICAL						CAPACITY		f _{max} MHz	BASE
								E _b V	I _b mA	P _p W	E _b V	E _{g2} V	E _{g1} V	I _b mA	I _{g2} mA	S _m mmho	μ	R _p Ω	IN pF		
6S26B-K	TRI	SIN	T3B	H	6.3	200	250	15	1.4	120	2	9	5.0	25	220K	3.3	3.5				
6S27B-K	TRI	SIN	T3B	H	6.3	200	300	7	1.4	250		/5	4.0	65	16K	3.3	3.4				
6S28B-V	TRI	SIN	T4B	H	6.3	310	150	35	2.4	120		16	19.0	40	2500	5.8	2.2				
6S29B-V	TRI	SIN	T4B	H	6.3	310	150	35	2.4	120		16	19.0	40	2500	9.5	3.9				
6S30B	TRI	SIN	T3B	H	6.3	425	200	60	5.0	50		40	21.0	17	800K	7.0	1.5				
6S33S	TRI	SIN		H	6.3																
6S34A-V	TRI	SIN	T2B	H	6.3	127	200	15	1.4	100		8	4.6	25		2.0	2.3				
6S35A-V	TRI	SIN	T2B	H	6.3	127	300	7	0.9	200		3	4.0	70	17K	2.0	3.3				
6S36K	TRI	SIN	C5	H	6.3	320	300	10	3.0	250	/1	6	8.0	145	18K	3.5	0.2	9K			
6S37B	TRI	SIN	T3B	H	6.3	440	300	70	4.5	120		40	16.5	13	800K	6.0	4.7				
6S39S	TRI	SIN	T20	VR	6.3	200	30K	/3					.2								
6SK7	TRI	PND		H	6.3	300			100		3	3	.5	8		2.5	3.0		DW6		
6SK7	PND	TRI		H	6.3	300			250	100	3	6	1.1			3.2	12.5				
6TS4P	DWD	SIN	T6	H	6.3	600	1K	300	3.0	350		37									
6TS4S	DIO	SIN		H	6.3	600	1K	300				75									
6TS5S	DWD	SIN	T10	H	6.3	600	1K	300	400			37							DW7		
6TS10P	DIO	SIN	T6	H	6.3	1050	4K	450	1K			120				5.0			9BD		
6TS13P	DIO	SIN	T7	H	6.3	950	/2K	900	8.0	650		120							6BY		
6TS15S	DIO	TWN	T13	H	6.3	1430	1K	375	350			62							8AN		
6TS17S	DIO	SIN	T10	H	6.3	3000	4K	1200													
6V1P	PND	SIN	T6	SM	6.3	400			4.5	250	250	2	26	2.7	29.0	9.0	4.6		PS5		
6VKH1	DWD	SIN		H	6.3	600	1K	200				70							DW7		
6YE1P	TRI	SIN	T5	ID	6.3	300	250		0.2	250	4	5	1.2	24					ID1		
6YE5S	TRI	SIN	T11	ID	6.3	300	250		250		4	5	1.2	24					8B		
6ZH1B	PND	SIN	T3F	H	6.3	200	150	14	1.2	120	120	/8	3.5	4.8	200K	4.8	3.8				
6ZH1L	PND	SIN	F10	H	6.3	150			2.0	150	75	2	0.2	1.5	1M	4.0	4.2	200	PS1		
6ZH1P	PND	SIN	T6	UF	6.3	170	200	20	1.8	120	120	2	7	3.0	300K	4.3	2.4	120	7BD		
6ZH1ZH	PND	SIN	ACO	H	6.3	150	250		0.5	250	100	3	0.7	1.6	1M	3.5	3.0				
6ZH2B	PND	SIN	T3F	RF	6.3	200	150	14	0.9	120	120	2	/6	6.0	500K	4.9	4.1				
6ZH2M	PND	SIN	T6	RF	2.0	60			0.5	120	70	/1	2	0.5	.9	5.4	8.1				
6ZH2P	PND	SIN	T6	RF	6.3	170	200	20	1.8	120	120	0	6	5.0	100K	4.5	2.4		7CM		
6ZH3	PND	SIN	M8	RF	6.3	300	330		3.3	250	150	1	11	4.0	900K	8.5	7.0		8BK		
6ZH3M	PND	SIN		H	6.3	450	300		3.0	300	200	10	2.5	5.0	700K	11.0	5.0		8N		
6ZH3P	PND	SIN	T5	UF	6.3	300	330		2.5	250	150	/2	7	2.0	800K	6.5	1.5		7BD		
6ZH4	PND	SIN	M10	H	6.3	450	330		3.3	300	150	0	10	2.2	900K	11.0	5.0		8N		

GROUP II, RECEIVING

TYPE NUMBER	KIND	TYPE	BULB	USE	CATHODE	E _f V	I _f mA	MAXIMUM			TYPICAL							CAPACITY			BASE			
								E _b V	I _b mA	P _p W	E _b V	E _{g₂} V	E _{g₁} V	I _b mA	I _{g₂} mA	S _m mmho	μ	R _p Ω	I _n pF	I _{out} pF		f _{max} MHz		
6ZH4E	PND	SIN	M10		H	6.3	450	330	2.5	300	150	0	9	2.2	8.5									8N
6ZH4P	PND	SIN	T5		H	6.3	300	300	3.5	250	150	1	11	4.3	5.7									7BK
6ZH5A *	PND	SIN			H	6.3	450			250	100		10	2.5	9.0									7BK
6ZH5B	PND	SIN	T3F		H	6.3	250	150	2.6	120	120	2	15	6.0	10.0									7BK
6ZH5P	BEA	SIN	T6		H	6.3	450	300	3.6	300	150	2	10	2.0	9.0									7BK
6ZH6S	PND	SIN	M10		H	6.3	500		2.5	250	100	2	10	2.5	7.5									7R
6ZH7	PND	SIN	M10	RF	H	6.3	300	330	0.8	250	100	3	2	0.6	1.2									7R
6ZH8	PND	SIN	S11	RF	H	6.3	300	330	2.8	250	100	3	3	0.8	1.6									8N
6ZH8S	PND	SIN			H	6.3	300			100	100	3	3	0.9	1.6									8Y
6ZH9B	PND	SIN	T4F		H	6.3	310			120	120		15		17.0									
6ZH9P	PND	SIN	T6		H	6.3	300	250	3.0	150	150	1	15	5.0	17.5									9EQ
6ZH10B	PND	SIN	T3F		H	6.3	250	150	0.8	120	120	1	11	9.0	5.0									
6ZH10P	PND	SIN	T6		H	6.3	300	250	3.0	200	100	1	6	5.5	9.5									9EQ
6ZH11P	PND	SIN	T6		H	6.3	440	150	4.9	150	150	/2	25	5.0	2.8									9EQ
6ZH13L	PND	SIN	M12		H	6.3	300			250	250	17	10	1.4	7.7									P18
6ZH20P	DIO	BEA	T6		H	6.3	450			6			31											PD1
6ZH20P	BEA	DIO	T6		H	6.3	450		3.0	150	150	1	18	4.0	17.0									PD1
6ZH21P	DIO	BEA	T6		H	6.3	350			12			35											PD2
6ZH21P	BEA	DIO	T6		H	6.3	350	200	3.0	150	150	1	17	4.0	17.0									PD2
6ZH22P	DIO	BEA	T6		H	6.3	480			12			65											PD2
6ZH22P	BEA	DIO	T6		H	6.3	480	200	5.5	150	150	1	28	7.0	30.0									PD2
6ZH23P	PND	DBA			H	6.3	440	150	2.4	150	150	2	12	7.5	14.0									PD3
6ZH31B-	PND	SIN	T6		H	6.3	175	200	1.8	120	120	2	7	2.5	5.0									7BD
6ZH32P	PND	SIN	T6		H	6.3	200	300	1.0	250	140	2	3	1.0	1.8									P17
6ZH33A	PND	SIN	T2B		H	6.3	127	150	1.3	120	100		8	4.0	4.5									
6ZH33A-	PND	SIN	T2		H	6.3	127	150	1.3	120	100		8	4.0	4.5									
6ZH35B-	PND	SIN	T3		H	6.3	127	150	0.9	120	110	2	6	6.5	3.1									PS5
EM7	TRI	SIN	T3B		F	1.0	18			7		2	2000	/0.1	/2									
7P12S	PND	SIN	S12		H	7.3	850	200	8.0	135	135	15	31	7.0	2.8									5F
7ZH12S	PND	SIN	S12		H	7.3	425	250	1.9	250	135	3	5	1.1	1.8									6F
10P12S	PND	SIN	S12		H	10.0	640	200	8.0	180	135	15	31	7.0	2.1									5F
10ZH1L	PND	SIN	F10		H	10.0	93	250	2.0	150	75	2	7	0.5	1.6									PS1
10ZH3L	PND	SIN	F10		H	10.0	93	250	2.0	150	75	2	7	0.5	1.6									PS1
10ZH12S	PND	SIN	S12		H	10.0	320	250	1.9	250	135	3	6	1.0	1.8									6F
12B1M	PND	DWD			H	12.5	220			25	25	1	1	0.4	1.9									PD5

GROUP II, RECEIVING

TYPE NUMBER	KIND	TYPE	BULB	USE	CATHODE	E _f V	I _f mA	MAXIMUM				TYPICAL						CAPACITY		f _{max} MHz	BASE
								E _b V	I _b mA	P _p W	E _b V	E _{q2} V	E _{q1} V	I _b mA	I _{o2} mA	S _m mmho	μ	R _p Ω	IN pF		
12B2M	PND	DWD			H	12.5	150		25	25	1	1	0.3	.8	150K				PD6		
12G1	TRI	DWD			H	12.6	150	275	2.7	250	9	9		1.9	16	8500	3.6	2.8	8Q		
12G2	TRI	DWD			H	12.6	150	330	0.9	250	2	1		1.1	100	90K	3.2	3.0	8Q		
12K1M	PND	SIN			H	12.5	225		25	25	/2	2	0.5	1.4	200K				7R		
12K3	PND	SIN			H	12.6	150	330	4.4	250	100	1	9	2.0	800K	6.0	7.0	8N			
12K4	PND	SIN			H	12.6	150	330	3.3	250	125	1	11	4.7	900K	3.3	8.5	8N			
12KH3S	DWD	SIN	F10		H	12.6	73	250	0.1			1				0.5		1G	DW8		
12M1M	PND	TRI			H	12.5	225			25	1	1	0.3	1.9	7500				PT3		
12N4P	TRI	TWN			H	12.6	150		1.5	250	4	3		1.8	40	22K	1.6	1.6	9AJ		
12N10S	TRI	DUO	T11		H	12.6	150	275	1.1	250	2	2		1.3	70	54K	1.5	0.2	8S		
12N11S	TRI	TWN			H	12.6	150		1.8	180	6	7		1.9	16	8500	3.2	2.6	8BE		
12P4S	PND	SIN	T11		H	12.6	160			250	12	38		3.8					7S		
12P14S	BEA	SIN			H	12.6	150		7.5	250	12	30		3.0			9.0	9.0	7S		
12P17L	PND	SIN	F11		H	12.6	325	250	7.5	150	150	20	35	7.0		10.0	8.5	120	P3S		
12S2	TRI	SIN			H	12.6	150			250	8	9		2.0	20	3.4	3.6		8T3		
12S3S	TRI	SIN			H	12.6	100	300	5.0	100	4	27		3.0	12	4100	1.5	0.6	11H	TS3	
12ZH1L	PND	SIN	F10		H	12.6	75	250	2.0	150	75	2	7	0.5	1.6	1M	4.0	4.2	200	PS1	
12ZH1M	PND	SIN			H	12.5	225			25	/2	2	2	0.5	1.4	200K				7R	
12ZH3L	PND	SIN	F10		H	12.6	75	250	2.0	150	75	2	7	0.5	1.6	1300	4.0	4.2		PS1	
12ZH8	PND	SIN	F10		H	12.6	150	330	2.8	250	100	3	3	0.8	1.6	2M	6.0	7.0		8N	
13P1S	BEA	SIN		PA	H	13.0	765		6.0	110	80	2	52	7.5			15.5	10.5			
15A6S	PND	SIN			H	15.0	300			180	135	48		2.5	30K						
25P1	BEA	SIN			H	25.0	300		10.0	110	110	80		8.5							
25P1S	BEA	SIN			H	25.0	300		10.0	110	110	80		8.5							
30P1S	BEA	SIN	T11	PA	H	30.0	300	110	7.0	110	110	7	70	12.0	10.0	9K	19.0	11.0		7S	
30TS1M	DIO	SIN			H	30.0	300	300		300	250	90								5AA	
30TS6S	DIO	TWN			H	30.0	300	300		150		60								8AN	
30VD1	DIO	SIN				25.0	300	500		500		500								4BQ	
30VKH1	DIO	TWN			H	30.0	300	500		150	120	1	60	1.6	250K					8AN	
SB-47	PND	SIN			H	4.0	150			160		5	0.7	1.6							
SB-51	PND	SIN			H	4.0	80			240	80	1	3	0.6	1.0	600K					
SO-57	PND	SIN			H	4.0	1A			240	100	1	3	0.8	3.0	500K					
SB-112	PND	SIN			H	4.0	80			160	80	1	2	0.6	.6	500K					
SO-124	PND	SIN			H	4.0	1A			160	60	2	5	3.5	2.0						
UB-132	* TRI	SIN			F	4.0	150		3.0	160		6	15	2.1	9	4K					

GROUP III, POWER

TYPE NUMBER	KIND	TYPE	BULB USE	CATHODE	E _f V	I _f mA	MAXIMUM				TYPICAL							CAPACITY			BASE
							E _b V	I _b mA	P _p W	E _b V	E _{g₂} V	E _{g₁} V	I _b mA	I _{g₂} mA	S _m mmho	μ	R _p Ω	IN pF	OUT pF	f _{max} MHz	
GS9B	TRI SIN	C11		H	12.6	1100	1K	4A	3.0H	1K		120	19.5			8.4	31.5	2G			
G10	TRI SIN				4.1	900			20.0	400		25	.6								
GU10A	TRI SIN	W21		T	7.0	75A	8K	15A	10.0K	2K		3A	20.0			40.0	34.0	25			
GU10B	TRI SIN	A21		T	7.0	75A	6K	15A	7.0K	2K		2500	20.0			40.0	34.0	25			
MO-10	TRI SIN				16.5	52A		10A	10.0K	10K			7.0								
GI-11B	TRI SIN	C8		H	12.6	815	2K	1A	8.0	400		15	10.0			11.0	2.6	3G			
GU11A	TRI SIN	W27		W	12.7	240A	10K	20A	20.0K	5K		3A	20.0			55.0	45.0	25			
GU11B	TRI SIN	C8		H	12.6	815	2K	1A	80.0	400		15	10.0			11.0	2.6	3G			
GI-12B	TRI SIN	C8		H	12.6	815	2K	1A	80.0	400		15	10.0			11.0	2.6	3G			
GU12A	TRI SIN	W25		W	12.6	315A	10K	30A	20.0K	4K		3A	23.0			35.0	24.0	50			
G-13	TRI SIN	T11		H	6.3	1100	2K		1.0			16	2.2			2.6	1.1	4BB			
GI-13	TRI SIN	C9		H	12.6	650	800	/4A	80.0									3G			
GI-13B	TRI SIN	C8		H	12.6	650	800		80.0									3G			
GM13	TET SIN	T34		H	26.0	4750	28K	45A	80.0	28K		70	4.0			16.2	14.0	30 P13			
GU13	BEA SIN	T20		T	10.0	5A	2K		1.0H	2K	400	35									
GI-14B	TRI SIN				12.6	3400	21K		5.0H	2K		250	35.0			10.5	12.5	1G			
GU15	BEA SIN	F16		F	4.4	680	400	85	15.0	220	200	14	50	7.5				60 P55			
GI-16B	TET SIN	A60		W	8.3	115A	8K		H8.0												
GU16B	TRI SIN	A23		W	13.5	200A	8K	15A	10.0K	5K		1500	25.0			55.0	42.0	25			
G-17B	TRI SIN	C11		H	12.6	2A	9K		3.0	1K		150	22.0			11.3	4.8				
GI-17	TRI SIN	A16		H	6.3	750	8K		1.0H	2K		10A	45.0			11.0	8.0	500			
GU-17	BEA TWN	T7		H	6.3	800	400	100	12.0	200	200	16	20	6.0		6.5	2.7	250 PD7			
GI-18B	TRI SIN	A50		T	12.5	190A	16K	150A	6.0K	10K		1A	25.0			75.0	50.0	/1			
GU-18	BEA TWN	T13		H	6.3	1200	600	130	20.0	250	200	35	6.0	1.5		7.0	2.6	600 PD8			
GI-19B	TRI SIN	W33		H	7.3	20A	14K	100A	1.0K	1K		500	20.0			50.0	12.0	150			
GU-19	BEA TWN	T16		H	6.3	2000	750	280	40.0	350	250	17	40	8.0		10.0	3.5	500 PD8			
GK20	TRI SIN				5.6	850		200	20.0	750			1.7								
MO20	TRI SIN				22.0	61A		10A	20.0K	10K			7.0					3G			
GI-21B	TRI SIN	C8		H	12.6	900	800	/4A	H1.1	600		75	26.0			55.0	45.0	26			
GU21B	TRI SIN	A30		T	8.3	150A	9K	30A	10.0K	9K		3700	30.0								
GI-22	TRI SIN	C8		H	6.3	640		/2A	10.0	200		30	18.0					6G			
GU22A	TRI SIN	W25		T	8.3	150A	10K	30A	20.0K	10K		2730	27.0			55.0	45.0	26			
GU23A	TRI SIN	W44		T	12.0	210A	11K		60.0K	10K		7900	49.5					26			
GU-23B	TRI SIN	A		W	12.0	210A	11K		50.0K				42.0					26			
GI-24A	TRI SIN	W30		W	6.3	425A	27K	250A	25.0K	4K		150A	40.0					200			

GROUP III, POWER

TYPE NUMBER	KIND	TYPE	BULB	USE	CATHODE	E _r V	I _r mA	MAXIMUM				TYPICAL						CAPACITY		f _{max} MHz	BASE
								E _b V	I _b mA	P _p W	E _b V	E _{g₂} V	E _{g₁} V	I _b mA	I _{g₂} mA	S _m mmho	μ	R _p Ω	I _n pF		
M57	TRI	SIN				16.0	10A	4.0H	10K			1200	2.9	52	18K						
GM60	TRI	SIN	T32	W		17.0	8A	6.0H	1K			100	2.2			11.4	4.9	3G			
G61	TRI	SIN				16.5	52A	10.0K						47		8.0	12.0				
G62	TRI	SIN				16.5	51A	10.0K				10A	7.0	47	7K	8.0	12.0	IF			
G65	TRI	SIN				5.2	1300	12.0				60	1.0	60	60K	18.0	17.0	20	P12		
G68	TRI	SIN				17.0	18A	1.0K	10K			2A	5.0	180	36K						
GI-70B	TRI	SIN	C11	H		12.6	2100	9K	1K			150	22.0								
GM-70	TRI	SIN	T21	T		20.0	3A	1.0H	600			200	6.0	7							
GM-70B	TRI	SIN	T21	T		20.0	3A	1.0H	600			200	6.0	7							
GK71	PND	SIN	T21	T		20.0	3A	1.0H	600	400		200	62.0	4.2							
GU72	PND	SIN	T25	T		20.0	3A	1.0H	750	400		150	4.2								
M74	TRI	SIN						450				.1	63								
GI-76B	TRI	SIN	C			12.6	2100	9K	1K			150	22.0								
GU80	PND	SIN	T30	T		12.6	10A	3K	2K	600	140	200	5.5								
M80	TRI	SIN				11.0	3500	80.0	1K			260	1.4	10							
GU81	PND	SIN	T38	F		12.6	10A	3K	2K	600											
GMI-83	TET	SIN	T20	H		25.0	2000	20K	15A	65.0	15K	1K									
G88	TRI	SIN				6.0	4A	600													
GMI-89	TET	SIN	T32	H		25.0	4000	25K	20A	1.0H	25K	1K									
GU89A	TRI	SIN	W24	W		11.0	124A	8K	9A	5.0K	1K	3A	10.0	20							
GU89B	TRI	SIN	A24	W		11.0	124A	8K	9A	5.0K	1K	3A	10.0	20							
M89	TRI	SIN				11.0	6300	H4.5	1K												
GMI-90	TET	SIN	T46	H		25.0	7800	33K	40A	1.0H	33K		4.0	9	1800						
GS90B	TRI	SIN	C12	H		12.6	1100	2K	4500	15.0	1K	175	19.5								
G91	TRI	SIN				11.0	6200	600				400	.9	10	5K						
GKE100	* TET	SIN	T20	H		11.0	2A	/2K	500	1.0H	15K	250	2	225							
GM100	TRI	SIN	T60	W		17.0	18A	5K	1600	1.0K	1K	600	6.5	18							
G120	TRI	SIN				16.5	52A	4K	11A	5.0K	4K	700		14							
GI-150	TRI	SIN	C8	H		12.6	815	800	/5A	20.0	400	15	10.0								
GKE150	* TET	SIN		H		11.0	6300	420	1.0H	3K	500		2.0	350							
GU150	TRI	SIN				11.0	10A		710	H1.5	2K		2.2	17							
M150	TRI	SIN				11.0	6300		420	H1.5	3K		1.4	11							
G256	TRI	SIN						30.0	450												
GKE300	TET	SIN		H		17.0	10A	4.0H	3K	500		750	3.9	400							
M400	TRI	SIN				17.0	18A	4.0H	1K			2300	6.0	10							

GROUP III, POWER

TYPE NUMBER	KIND	TYPE	BULB	USE	CATHODE	E _f V	I _f mA	MAXIMUM				TYPICAL						CAPACITY		BASE
								E _b V	I _b mA	P _p W	E _{o2} V	E _{o1} V	I _b mA	I _{o2} mA	S _m mmho	μ	R _p Ω	IN pF	OUT pF	
GU24A	TRI	SIN	C8		H	3.3	/2KA	6K		25.0K										273
GI-25	TRI	SIN	W30		T	6.3	1145	/2K		12.0	250									5G
GU25B	TRI	SIN	W		H	8.3	150A	12K		12.0K										26
GU26A	TRI	SIN			T	30.0	17A	6K		10.0K										330
GU26B	TRI	SIN			T	12.0	210A	12K	60A	50.0K										
GU27A	TET	SIN	W13		T	7.5	25A	4K	5A	2.0K	2K	1K								110
GU27B	TET	SIN	A24		T	7.5	25A	3K	5A	8.0H	3K	1K								110
GU-28A	TET	SIN	W20		T	6.3	98A	10K	98A	8.0K	3K	850								24
GU28B	TET	SIN	A		T	6.3	98A	10K		10.0K	3K	2K								30
M28	TRI	SIN				11.0	6400			11.5	1K									
G29	TRI	SIN				16.0	10A		1200	4.0H	10K									
GU29	TET	TWN	T16		H	6.3	2250	750	250	40.0	600	200	70							200
GI-30	BEA	TWN	T16		H	6.3	2250	5K	9A	15.0	250									7BP
GMI-30	TRI	SIN	G44		T	8.2	17A	27K	15A	3.0H	2K									7BP
GU30A	TRI	SIN	W		T	10.5	220A	7K	50A	60.0K										100
GU31	TET	SIN				6.3				450	200									
G32	TRI	SIN				3.2	3500			15.0	800									
GU32	BEA	TWN	T14		H	6.3	1600	750		15.0	250	130	10							2.4
GU33B	TET	SIN			H	6.3	5A	1K		1.0H	15H	400								
GU34B	TET	SIN	T20		H	12.6	4A	4K		5.0H	2K	600								2.0
GU-35B	TET	SIN	A		W	6.3	65A	5K		K3.5	5K	800								250
G36	TRI	SIN				5.6	860			20.0	600									
GU-36B	TET	SIN	A		W	8.3	100A	6K		14.0K	6K	1K								250
GU-37B	TRI	SIN	A		W	3.4	110A	3K		K3.5										330
GU-39A	TET	SIN	W		W	6.3	98A	10K		8.0K		2K								100
GU-39B	TET	SIN	A		W	6.3	98A	10K		6.0K		2K								100
M39	TRI	SIN				11.0	3500			30.0	1K									
GU-40B	TET	SIN	A		W	6.3	33A	/3K		2.0K	2K	900								250
G46	TRI	SIN				11.0	4100		250	80.0	1K									250
G47	TRI	SIN				11.5	3800		215	11.5	3K									
GU50	PND	SIN	F12		H	12.6	765	1K	230	40.0	800	250	100							14.0
M50	TRI	SIN				11.0	6300		270	50.0	1K									9.2
GM51A	TRI	SIN	W19		W	22.0	102A	12K	10A	15.0K	5K									12
M53	TRI	SIN				11.0	6300			11.5	3K									
GM57	TRI	SIN				4.0	2100			4.0	750									8.5

GROUP IV, RECTIFIER TUBES

TYPE NUMBER	KIND	TYPE	BULB	GAS	CATHODE	E _f V	I _f mA	MAXIMUM		TYPICAL	
								E _b V	I _b mA	E _b V	I _b mA
GG-1-0.3/8	DIO	SIN	T14	AR	H	6.3	4A	8K	1A	30	/1
GG-1-0.5/20	DIO	SIN	T21	AR	H	6.3	5A	20K	3500	30	/1
GG-1-1/22	DIO	SIN	T30	GS	H	6.3	14A	22K	1A	30	1
GG-1-2/5	DIO	SIN	T22	XE	H	6.3	6500	9K	6500	16	2
GG-1-2/16	DIO	SIN	T30	AR	H	6.3	16A	16K	7A	30	2
GR1-02/15	DIO	SIN	S16	HG	F	5.0	3300	/2K	800		235
GR-1-0.3/8.5	DIO	SIN	S21	AR	F	6.3	4A	8K	1A	30	/1
GR-1-25/15	DWD	SIN		GS	F	5.0	3A	/2K	800	500	125
GRI-0.25/1.5	DWD	SIN	S17		F	5.0	3300	16H	800		235
I-1-70/0.8	TRI	IGN	W48	HG	C			800			70A
I-1-100/1.5	TRI	IGN	W52	HG	C			15H	3HA		1HA
I-1-140/0.8	TRI	IGN	W56	HG	C			800			1HA
I-1-350/0.8	TRI	IGN	W70	HG	C			800			3HA
V1-00313	DIO	SIN	T10		F	2.5	4600	13K	3000		30
V1-02/20	DIO	SIN	T13	VC	F	2.5	3200	20K	100		20
V1-03/13	DIO	SIN	T9	VC	F	2.5	4650	13K	3A		30
GG1-0.5/5	DIO	SIN	S21	KX	F	2.5	8500	5K	1500		500
V1-05/70	DIO	SIN	T32	VC	F	5.0	32A	70K	8A		50
V1-06/30	DIO	SIN						30K			60
V1-1/2.5	DIO	SIN	W12	VC	F	15.0	12A	25H	1000		
V1-1/30	DIO	SIN	T18	VC	F	5.0	5A	30K	600		100
V1-1/40	DIO	SIN	T17	VC	F	5.0	6A	40K	750		100
V1-2/40	DIO	SIN						40K			200
V1-3/16	DIO	SIN	A27	VC	H	6.3	10A	16K	1500		300
V1-3/70	DIO	SIN						70K			300
V1-4/40	DIO	SIN	G70	VC		7.5	48A	44K	2A		450
V1-15/55	DIO	SIN	T31	VC	F	6.3	7500	55K	700		180
VG1/8500	DIO	SIN		GS	F	2.5	5500	8K	1A	6K	300
VI-1-5/20	DIO	SIN	T16	VC	H	6.3	29A	20K	5000		
VI-1-5/30	DIO	SIN	A16	VC	W	6.3	95A	30K	2000		
VI-1-18/32	DIO	SIN	A23	VC	H	17.0	3700	40K	20A		500
VI-1-27/35	DIO	SIN	A40	VC	H	9.0	145A	35K	70A		
VI-1-30/25	DIO	SIN				10.0	6A	25K	30A		30
VI-1-70/32	DIO	SIN						32K	70A		
VI-1-10050	DIO	SIN						50K	100A		
VO-1	DIO	SIN			H	4.0	3200			850	40
I-2-50/1.5	TRI	IGN	W52	HG	C			15H	1HA		50A
VI-2-27/35	DIO	SIN	W20	VC	H	9.0	145A	35K	70A		
VI-2-70/32	DIO	SIN	A21	VC	H	12.6	5300	32K	70A		70
VI-2-100/50	DIO	SIN	A30	VC	H	12.6	36A	50K	100A		

GROUP IV, RECTIFIER TUBES

TYPE NUMBER	KIND	TYPE	BULB	GAS	CATHODE	E _f V	I _f mA	MAXIMUM		TYPICAL	
								E _b V	I _b mA	E _b V	I _b mA
2V6	DIO	ARC		HG	C			400	6A		
2V12	DIO	ARC		HG	C			1K	1A		
2V20	DIO	ARC		HG	C			750	20A		
2VN12	DIO	ARC		HG	C			450	12A		
2VN20	DIO	ARC		HG	C			750	20A		
3V30	DIO	ARC		HG	C			750	30A		
3VN30	DIO	ARC		HG	C			750	30A		
3VN60	DIO	ARC		HG	C			400	60A		
3VN100	DIO	ARC		HG	C			600	100A		
I-20/1.5	TRI	IGN	W25	HG	C			15H	60A		20A
I-20/1500	*DIO	IGN	W19	HG	C			15H	1KA		20A
I-50/1.5	TRI	IGN	W35	HG	C			15H	1HA		50A
I-50/1500	*DIO	IGN	W26	HG	C			15H	2KA		50A
I-100/1.0	TRI	IGN	W70	HG	C			1K	6HA		1HA
I-100/5.0	TRI	IGN	123	HG	C			5K	3HA		1HA
I-100/1000	*DIO	IGN	W33	HG	C			1K	2KA		100A
I-100/5000	*DIO	IGN	W33	HG	C			5K	300A		100A
VU-111D	DIO	SIN	S		F	4.0	1500	12K	400	160	80
VO-125	DIO	SIN			F	4.0	700			250	60
VG-129	DIO	SIN	S20	HG	F	2.5	9A	7K	1500		500
I-150/1.0	TRI	IGN	W52	HG	C			1K	1HA		1HA
VG-161	DIO	SIN		HG	F	2.5	6A	/3K	1A	/2K	300
VG-163	DIO	SIN				5.0		15K	50A	18	
VG-176	DIO	SIN	G16		M	2.5	11A	150	9A	20	
VO-188	DWD	SIN			F	4.0	2A			500	155
VO-196	DIO	SIN			H	4.0	3A			750	250
VO-197	DWD	SIN			F	4.0	5A			250	300
I-200/1.5	TRI	IGN	W65	HG	C			15H	6HA		2HA
I VS 200/2		IGN	W	HG	C			/3K	450A	16	150
VO-202	DWD	SIN			F	4.0	700			250	60
VO-230	DIO	SIN			F	4.0	700			350	50
VG-236	DIO	SIN				2.5		7K	4A	16	
VG-237	DIO	SIN	G32		F	5.0	22A	10K	10A		3500
VO-239	DIO	SIN			F	4.0	2A			850	180
VG-252	DIO	SIN				2.5		300	30A	15	
I-1-350/0.8	TRI	IGN	IV								
VO-360	DIO	SIN			F	4.0	1A			500	100
T-409	*DIO	IGN	G14	HG	C			3K	200A		
T-410	*DIO	IGN	G17	HG	C			14K	20A		
T-411	*DIO	IGN	G17	HG	C			19K	100A		
1502	DIO	SIN	F13		H	5.0	3000	/2K	1200	500	400

GROUP V, VOLTAGE REGULATOR TUBES

TYPE NUMBER	KIND	GAS		CATH MAT'L	VOLT. RANGE		CUR. RANGE		DIMEN		BASE
		KIND	PRES		MAX	MIN	MAX	MIN	DIA	LTH	
			mm		V	V	mA	mA	mm	mm	
SG1P	REG	AHE			190	145	30	5	22	65	7DN
SG1P-V	REG				170	145	30	5	22	65	7DN
SG1P-YE	REG				170	143	30	5	22	65	7DN
SG2P	REG	AKN			150	104	30	5	22	65	7DN
SG2S	REG	NA	30		110	70	40	5	32	75	4AJ
SG3P	REG	AHE			170	144	40	5	22	65	
SG3S	REG	AHN	30		133	105	40	5	32	75	4AJ
SG4S	REG	AHE	30	NI	180	145	30	5	32	75	4AJ
SG5B	REG	AHE			190	142	10	5	10	36	
SG5B-V	REG				170	142	10	5	10	36	
SG7S	REG				480	390	0.1	0.003			
SG8S	REG				970	880	0.1	0.003	10		
SG9S	REG				13H	12H	0.1	0.01	10		
SG10S	REG	NK			150	86	15	4	32	40	
SG13P	REG	AHN	55	NI	180	143	30	5	19	55	7DN
SG15P	REG	AHN	54	MO	150	104	30	5	19	55	7DN
SG15P1	REG				160	103	30	5	19	60	
SG16P	REG	NA	40	MO	130	80	30	5	19	55	7DN
SG17S	REG	NEH			1350	850	60	10	38	189	
SG18S	REG	NEH			1500	950	60	10	38	189	
SG19S	REG	NEH			1650	1050	60	10	38	189	
SG20G	REG				135	85	15	4	10	45	
SG201S	REG	NK	50	MO	150	86	15	4	32	40	7DN
SG202B	REG	NA	35	MO	140	81	5	1.5	10	40	
SG203K	REG				150	79	10	1	12	20	
SG226	REG	NE			95	70	40	8	50	130	
SG227	REG	NE			95	70	60	10	65	135	
SG301S	REG	HY	16	NI	439	380	0.1	0.0003	12	55	
SG302S	REG	HY	82	NI	970	880	0.1	0.0003	12	55	
SG303S	REG	HY	143	NI	1350	1220	0.1	0.01	12	55	
SG304S	REG	HY			4200	3800	1	0.05	25	129	
SG305K	REG				10K	9K	1.5	0.05	33	180	
SG306K	REG				26K	24K	1.5	0.05	48	245	

GROUP VI, CURRENT REGULATOR TUBES

TYPE NUMBER	KIND	TYPE	BULB	VOLT. RANGE		CUR. RANGE		BASE
				MAX	MIN	MAX	MIN	
				V	V	mA	mA	
024B12-18	BAL	SIN	T10	18	12		255	
03B17-35	BAL	SIN	T14	35	17		300	8ES
03R65-135	BAL	SIN	T14	135	65		300	8ES
0425B55-12	BAL	SIN		12	/6	460	425	8ES
085B55-12	BAL	SIN	T9	12	/6	920	780	8ES
1B5-9	BAL	SIN	T14	9	5		1000	DS7
1B10-17	BAL	SIN	T14	17	10		1000	DS7
ST2S	BAL	TWN		17	6		2000	DS6
ST3P	BAL	SIN	T6	6	4	880	720	

GROUP VII, THYRATRONS

TYPE NUMBER	KIND	BULB		GAS	CATHODE			MAXIMUM ANODE				AVG I _b mA	MAXIMUM GRID				BASE					
		SHAPE	LTH mm		DIAM mm	KIND	E _f V	I _f mA	WARM-UP MIN. S	PIV V	E _f V		FIRING V	TUBE DROP V	PULSE I _b mA	BIAS V		INPUT RES kΩ	PULSE			
																			IGN. V	TIME μS	t _r nS	PPS 10 ³
TG1B	TRI	T	36	10	KX	H	6.3	225	10	240	240	30	20	120	20	100	1M	100	30	10		
TG1B-V	TRI	T	36	10	KX	H	6.3	225		240			16	120	20	28						
TG1-0.02/0.5	TET	T	38	19	XE	H	6.3	150	10	500	500	30	16	120	20	15	10M	15			8T1	
TG1-0.1/0.3	TRI		97	35	AR	H	6.3	660	30	300	300		20	300	75	80	500	80			8T3	
TG1-0.1/1.3	TET	T	105	39	KX	H	6.3	600	10	1300	650	25	11	500	100	100	10M	100	5	60	10	8T2
TG1-0.5/12	TRI	T	225	62	AR	H	6.3	5A	120	12K		500	27	3A	500	70	100					
TG1-1.0/0.8	TET	T	130	61	KX	H	6.3	300	60	800	420	50	15	600	1A	15	1M	15			10T	
TG1-1.5/2	TRI	T	160	68	XE	H	6.3	7500		2K			16	5A	15H	15						
TG1-1.6/1.3	TRI	T	201	66	XE	H	5.0	6A	90	1300	1K		20	10A	/2A	100	100	100				
TG1-2.5/4	TRI	S	255	85	KX	F	5.0	12A	60	4000	3K	140	20	8A	/3A	100	100	100			4T2	
TG1-2.5/10	TET	T	285	90	XE	H	5.0	15A		10K			16	8A	25H	50						
TG1-3.2/1.3	TRI		222	66	XE	H	5.0	8A	90	1300	1K		20	20A	3A	100	100	100				
TG1-5-3	TRI	T	350	110	KX	F	5.0	21A		3K			22	15A	5A	20						
TG1-6.4/1.3	TRI		242	66	XE	H	5.0	13A	120	1300	1K		20	40A	6A	100	100	100				
TG1-12.5/1	TRI	T	292	90	XE	H	5.0	16A		13H			20	80A	12A	20						
TG1-1B	TRI	T	40	10	XE	H	3.1	1500		500			20A									
TG1-1-3/1	TET	T	67	19	AR	H	6.3	1A	90	1000	1K		35	3A	6	40			12	300	5	
TG1-1-10/1	TRI	T	80	32	HY	H	6.3	2600	60	1000	2K		20A	50	100	15			6	150	40	
TG1-1-35/3	TRI	T	135	38	HY	H	6.3	2500	180	1500	3K		140	35A	45	100			6	500		
TG1-1-50/5	TRI	T	160	45	HY	H	6.3	3600	180	5K	5K		160	50A	50					/1	4	
TG1-1-90/8	TRI	T		60	HY	H	6.3	7000		8K			90A	100						/1	2	
TG1-1-130/8	TRI	T	180	64	HY	H	6.3	500		3K			1HA	150						/1	2	
TG1-1-130/10	TRI	T	205	62	HY	H	6.3	5A	240	10K	10K		150	1HA	250						4	
TG1-1-325/16	TRI	T	230	66	HY	H	6.3	8500		16K			150	3HA	200			200	/1		1	
TG1-1-400/3.5	TRI	S	280	85	HY	H	5.0	18A	180	3500	1K		4HA	300			2		20			
TG1-1-400/16	TRI	T	268	78	HY	H	6.3	10A		16K			170	4HA	500			200			/1	
TG1-1-700/25	TRI	T	450	135	HY	H	6.3	20A		20K			200	7HA	1A			700	/1		/1	
TKH-1	TRI		85	34	NE	C					150		60	100	30							
TKH1B	TRI					C					160		85	30	10			10M	85			
TR1-5/2	TRI	T	275	90	HG	H	5.0	15A		2K			15	15A	500	24						
TR1-6/15	TRI	T	350	90	HG	H	5.0	23A	900	15K			18	20A	6A	100	5					
TR1-15/15	TRI	T	490	95	HG	H	5.0	40A		15K			20	47A	15A	100						
TR1-40/15	TRI	G	700	245	HG	H	5.0	68A	3K	15K			20	1HA	40A	100	5					
TR1-85/15	TRI	T	760	270	HG	H	5.0	130A		15K			20	3HA	85A	100						
TR1-130/15	TRI	T		220	HG	H	5.0	130A		15K				3HA	85A							
TG2-0.1/0.1	TRI	T	105	40	XE	H	6.3	600	10	100	100		11	300	100	2	5M					
TG2-0.5/12	TRI	T	225	62	HY	H	6.3	7A		12K			70	/4A	500	100						
TG2.5/5	TRI				F		5.0	13A		3K			8A	2A	18							
TG1-2-260/12	TRI	T	285	90	HY	H	6.3	12A		12K				400				200			/5	
TG1-2-325/16	TRI				HY	F	6.3	8500		16K			3HA	200								
TG1-2-400/35	TRI				HY	F	5.0	18A		3500			4HA	300								
TKH-2	TRI		50	19	HE	C				350			80	100	12							
TG3-0.1/1.3	TET	T	57	19	KX	H	6.3	600		1300	650	30	11	500	100	100	10M	100	10	60	10	7EM
TG3-2.5/10	TRI	T	290	90	KX	H	5.0	20A		10K			25	8A	/3A	30						
TKH3B	TET	T	40	10	NA	C				190			110	5	2			20M	67	15		1
LP-4	COM				H		4.0	270		260				1		70						
TKH4B	TET		40	10	NA	C				225			115	7	3	99M	92	10				
LP-5	COM				H		4.0	370		200				100		40						
TKH-5A	TRI		25	7	NA	C				270			110	/1	/1							
MTKH90	TRI		30	12	NE	C				160			50	20		20M	85					
TG1-200	TRI	S	280	85	KX	F	5.0	15A	60	3500			20	2HA		18	200					
TG212M	TRI	T	105	35	AR	H	4.0	950	30	300	300		27	500	125	7	100					
TG-213	TRI				F		2.5	9A						1A	500	15						
TG-235	TRI				F		5.0	12A						6A	1A	16						

GROUP VIII, CATHODE RAY

TYPE NUMBER	METH. OF DEFLECTION		DIMENSIONS		CATHODE	TYPICAL						MAXIMUM		SCREEN COL. PERS. ANGLE (degree)	BASE		
	FOCUS	DEFL.	DIAM.	LENGTH		USE	HEATER		E _{Foc}	E _{A1}	E _{A2}	E _{A3}	E _{A4}			I _K	DEFL. SENS.
							V	I _{mA}									
LI-1	C		4	17	IC	H	6.3	510	400	1.2				50		F8	
LI-3	CELM	ELM	1	1	IC	H	12.6	300	650	1.0				50	250	A4	
PIM-3	C		6		IC					18.0						V B	
PIM-4	C		13		IC					18.0						V B	
LI-6	CELM	ELM	2	32	IC	H	12.6	300	850	1.3				50	250	A4	
LI-7	CELM	ELM	2	32	IC	H	12.6	300	850	1.3				50	250	A4	
LI-13	CELM	ELM	3	39	IM	H	6.3	600	285	0.6	0.9			35	150	C14	
LI-14	CELM	ELM	3	39	IM	H			270	0.6	0.9			35	150	C14	
LI-15	CELM	ELM	3	39	IM	H	6.3	600	285	0.6	0.9			35	150	C14	
LI-17	CELM	ELM	3	39	IM	H	6.3	600	285	0.6	0.9			35	150	C14	
LI-18	CELM	ELM	72	16	VI	H	6.3	450	600				80	1	B9		
LI-23	ELM	ELM	34	16			6.3	600	300	0.3			125				
LI-101	CELM		15		IC	H	13.6	300	800	1.2			5	50			
LI-201	CELM		15		IM	H	6.3	600	15H	0.4							
LI-203	ELM	ELM	77	39			6.3	600	270	1.5							
LI-401	ELM	ELM	34	16			6.3	450					150				
LO-247	ELS	ELS	11		OS		4.0	700	112	0.8			16	160	GR MD		
LO-248	ELS	ELS	11		OS		4.0	700	600	3.0			50		GR MD		
LO-249	ELS	ELS	11		OS		4.0	700	600	3.0			50		GR MD		
LO-709A	ELS	ELS	11		OS		2.5	21H	450	2.0			50		GR MD		
3LO1-I	ELS	ELS	3	12			6.3	600	100				60	300	GR MD		
5LO38I	CELM	ELM	5	19	OS	H	6.3	600	300	0.5	1.0		60	1M	BL MD		
6LK1B	CELM	ELM	6	27	PR	H	6.3	600			25.0		60	200	WH SH		
7LO1M	CELS	ELS	7	19	OS	H	6.3	600	235	1.4	2.8		76		PB SH		
7LO55I	CELS	ELS	7	19	OS	H	6.3	600	180	1.1	2.0		76		BL MD		
8LM3V	CELS	ELS	8	21	OS	H	6.3	600	400	0.7	4.0		50		WH LO		
8LO29I	CELS	ELS	8	26	OS	H	6.3	600	350	1.1	1.5		45		GR MD		
8LO29M	CELS	ELS	8	26	OS	H	6.3	600	350	1.1	1.5		45		GR MD		
8LO30I	CELS	ELS	8	27	OS	H	6.3	600	400	1.1	1.5		45		GR MD		
8LO30M	CELS	ELS	8	27	OS	H	6.3	600	400	1.1	1.5		45		PB SH		
8LO39V	CELS	ELS	8	27	OS	H	6.3	600	400	2.0	4.0		60	0.18	GR MD		
10LK2B	CELM	ELM	8	32	PR	H	1.5	73K	20.0				60	0.11	BL MD		
10LO43I	CELM	ELM	10	41	OD	H	6.3	600	550	1.0	2.5		120		WH MD		
13LK1B	CELM	ELM	12	37	TV	H	6.3	550		7.0			76	0.20	GR MD		
13LK2B	CELM	ELM	8	31	TV	H	6.3	500			4.0		25		WH MD		
13LM4V	CELM	ELM	13	29	OS	H	6.3	600		0.4	12.0		50		WH LO		
13LM31M	CELM	ELM	11	28	OS	H	6.3	600	250	6.0			70		YO LO		

GROUP VIII, CATHODE RAY

TYPE NUMBER	METH. OF		DIMENSIONS		CATHODE		TYPICAL										MAXIMUM		SCREEN		DEFL	BASE
	FOCUS	DEFL	DIAM	LENGTH	USE	E	I	E _{Foc}	E _{A1}	E _{A2}	E _{A3}	E _{A4}	E _{C1}	I _K	DEFL SENS	COL	PENS	ANGLE	mm/V	degree		
																					V	mA
13LM31V	CELM	ELM	13	29	OS	H	6.3	600	0.2	4.0			50			WH	LO	A8				
13LM56I	CELS	ELM	13	29	OS	H	6.3	600	0.7	4.0			50			GR	MD	A8				
13LM57	CELM	ELM	11	28	OS	H	6.3	600	250	6.0			71			GR	LO	A8				
13LM57D	CELS	ELM	13	29	OS	H	6.3	600	0.7	4.0			50			PB	LO	A8				
13LM58K	CELS	ELM	13	29	OS	H	6.3	600	0.7	4.0			50			RD	LO	A8				
13LO1B	ELS	ELS	13				2.5	2A	425	2.0			40			GR	MD					
13LO2B	ELS	ELS	13				6.3	600	500	1.8	3.0		50			GR	MD	14J				
13LO3I	CELS	ELS	14	43	OS	H	6.3	600	410	1.5	1.5	3.0	50			GR	MD	A14				
13LO4I	CELS	ELS	14	43	OS	H	6.3	600	425	1.5	1.5	5.0	50			GR	MD	A14				
13LO5P	ELS	ELS	13				6.3	600	500	1.8	3.0		50			YO	LO	14J				
13LO6P	ELM	ELM	13				6.3	600	250	6.0			45			YO	LO	A8				
13LO36	CELS	ELS	11	42	OS	H	6.3	600	690	2.0	4.0		60			YO	LO	14J				
13LO36V	CELS	ELS	14	43	OS	H	6.3	600	525	1.1	2.0	4.0	60			WH	LO	14J				
13LO37A	CELS	ELS	14	43	OS	H	6.3	600	400	1.1	1.5	3.0	50			BL	SH	14J				
13LO37I	CELS	ELS	14	43	OS	H	6.3	600	400	1.1	1.5	3.0	50			GR	MD	14J				
13LO37M	CELS	ELS	14	43	OS	H	6.3	600	400	1.1	1.5	3.0	50			PB	SH	14J				
13LO48A	CELS	ELS	14	41	OD	H	6.3	600	400	1.2	1.5		60			BL	SH	A14				
13LO48I	CELS	ELS	14	41	OD	H	6.3	600	400	1.2	1.5		60			GR	MD	A14				
13LO48M	CELS	ELS	14	41	OD	H	6.3	600	400	1.2	1.5		60			PB	SH	A14				
13LO54A	CELS	ELS	14	43	OS	H	6.3	600	300	1.1	1.5	6.0	750			BL	SH	B14				
13LO54M	CELS	ELS	14	43	OS	H	6.3	600	300	1.1	1.5	3.5	750			BL	SH	B14				
13LO54V	CELS	ELS	14	43	OS	H	6.3	600		1.1	1.5	6.0	750			WH	LO	B14				
13LO10M	ELS	ELS	12	32			6.3	600	1K				125			BL	SH					
13LO102M	ELS	ELS	13	61			6.3	750	1K				300			BL	SH					
13LO104A			13	54		H	6.3	600	700	.4	.8	1.2	1.8	100			BL	SH	D14			
18LK1B	ELM	ELM	17	35	TV	H	2.5	21H	3.5	15.0			35			WH	SH	D8				
18LK2B	CELM	ELM	14	42	TV	H	6.3	550					30			WH	SH	D8				
18LK3V	ELM	ELM	18				2.5	2A	3.5				60			GR	MD					
18LK4B	CELS	ELM	17	34	TV	H	6.3	600					60			WH	SH	B8				
18LK5B	CELM	ELM	17	35	TV	H	6.3	520					30			WH	SH	B8				
18LK7B	CELM	ELM	17	35	TV	H	6.3	560					35			WH	SH	B8				
18LK15	CELM	ELM	17	34	TV	H	6.3	550	5.0				38			WH	MD	B8				
18LM35	CELM	ELM	15	34	OS	H	6.3	600	250				48			YO	LO					
18LM35V	CELM	ELM	18	35	OS	H	6.3	600					50			WH	LO	A8				
18LO1P	ELM	ELM	18	47			6.3	600	250	6.0			45			YO	LO	A8				
18LO40B	CELS	ELS	18	36	TV	H	6.3	600	2.0				120			WH	MD	14G				
18LO47A	CELS	ELS	18	45	OD	H	6.3	600	1.0	2.0	6.0		100			BL	SH	A25				

GROUP VIII, CATHODE RAY

TYPE NUMBER	METH. OF DEFLECTION		DIMENSIONS		CATHODE	TYPICAL				MAXIMUM			SCREEN COL. PERS. ANGLE	DEFL. ANGLE degree	BASE	
	FOCUS	DEFLECT	DIAM. cm	LENGTH cm		USE	HEATER	E _{A1} kV	E _{A2} kV	E _{A3} kV	E _{A4} kV	E _{C1} V				I _k mA
						E V	I mA	E _{Foc} V								
18LO47V	CELS	ELS	18	45	OD	H	6.3	600	1.0	2.0	6.0	100		WH	LO	A25
19LK4B	CELM	ELM	17		TV	H	6.3	600	6.0			60		GR	LO	
20LM1YE	ELS	ELM	20	46			6.3	12H	750			60	300	WH	MD	D8
23LK1B	CELM	ELM	19	38	TV	H	6.3	550	8.0	10.0		18	100	WH	SH	D8
23LK2B	CELM	ELM	22	47	TV	H	6.3	550	8.0			18	100	WH	SH	D8
23LK7B	ELM	ELM	S18	40	TV	H	6.3	520	8.0					WH	SH	D8
23LK8B	ELM	ELM	S16	49	TV	H	6.3	550	15.0			100		WH	SH	D8
23LM34	CELM	ELM	19	43	OS	H	6.3	600	250	6.0	48			YO	LO	
23LM34V	CELM	ELM	23	46	OS	H	6.3	600	4.0		50			WH	LO	A8
23LO51A	CELS	ELS	23	57	OS	H	6.3	600	6.6	20.0	200		0.03	BL	SH	A20
30LK1B	C		30	45	TV	H	6.3	600	10.0		75					D8
31LK1B	CELM	ELM	31		TV	H	6.3	550	10.0			52	150	WH	MD	D8
31LK2B	CELM	ELM	30	47	TV	H	6.3	600	10.0			30	150	WH	SH	B8
31LM32	CELM	ELM	25	51	OS	H	6.3	600	250	6.0	48			YO	LO	
31LM32V	CELM	ELM	31	54	OS	H	6.3	600	4.0		50			WH	LO	A8
31LO1P	ELM	ELM	31				250	1.8			50			GR	MD	A8.
31LO33	CELS	ELS	25	56	OS	H	6.3	600	4.3	5.5	150			YO	LO	
31LO33V	CELS	ELS	31	57	OS	H	6.3	600	1.1	4.3	140			WH	LO	14J
35LK2B	CELS	ELM	35	46	TV	H	6.3	600	0.5	12.0	60	150		WH	SH	C8
40LK1B	CELM	ELM	40	49	TV	H	6.3	550	12.0		70	100		WH	MD	B8
42LM2YE	ELS	ELM	42	59			6.3	12H	4K		60	300		GR	LO	
43LK2B	CELS	ELM	S45	50	TV	H	6.3	600	0.3	0.3	14.0	25		WH	SH	70B12
43LK3B	CELS	ELM	S43	51	TV	H	6.3	600	0.5	14.0	60	150		WH	SH	B12
43LK6B	CELS	ELM	S45	30	TV	H	6.3	600	0.3	0.5	14.0	25		WH	SH	110A7
43LK7B	CELS	ELM	S45	50	TV	H	6.3	600	0.3	0.3	14.0	25		WH	SH	68B12
43LK8B	CELS	ELM	S45	50	TV	H	6.3	600	0.3	0.5	14.0	25		WH	SH	B7
43LK9B	ELS	ELM	S37	330	TV	H	6.3	600	0.3	1.0	14.0	90	30	WH	SH	110A7
45LM1B	ELM	ELM	40	56		H	6.3	600						WH	SH	A8
47LK1B	ELS	ELM	47	31	TV	H	6.3	300	16.0					WH	SH	110C8
53LK2B	CELS	ELM	S53	61	TV	H	6.3	600	0.5	16.0	60	150		WH	SH	B12
53LK3B	C		S50	58	TV	H	6.3	600	0.4	16.0	140					B7
53LK4TS	ELS	ELM	S47	65		H	6.3	72A	25.0					3C		
53LK5B	CELS	ELM	S45	38	TV	H	6.3	600	0.3	0.5	16.0	25	100	WH	SH	110B7
53LK6B	ELS	ELM	S48	385	TV	H	6.3	600	425	0.3	0.5	90	30	WH	SH	110A7
59LK1B	ELS	ELM	59	37	TV	H	6.3	300	16.0					WH	SH	110C8

GROUP IX, MICROWAVE TUBES

TYPE NUMBER	KIND	FREQ		DUTY CYCL	CATHODE OPERATE		MAXIMUM					COUPLING		DIMEN		WT. g				
		MIN Gc	MAX Gc		E _f V	I _f mA	E _b V	I _b mA	P _o mW	COL. V	E _g V	HELIX V	GAIN dB	NF dB	VSWR		BAND WIDTH	MAG. FIELD GAUSS	LTH mm	DIAM mm
2J55	MAG	13.3	13.3	1 P			12K	12A	53K						3350					
3J21	MAG	24.5	24.5	P			15K	15	60K											
4J26-30	MAG	1.2	1.2	1 P			27K	46A	700K						1400					
4J45	MAG	2.8	2.8	1 P			23K	45	650K											
4J50	MAG	12.1	12.1	1 P			22K	27A	28K						6900					
UV-5	TWT	3.4	4.4		3.0	900	180	1	100U	600	12	500	18	10	1.6	700	WG	388	33	83
UV-6	TWT	3.4	4.4		4.0	950	500	5	30	13H	30	11H	30		1.6	700	WG	388	33	95
UV-7	TWT	3.4	4.4		6.3	850		35	3000	16H	50	14H	26		1.6	800	WG	397	33	100
K-29	KLY	8.8	10.3		6.3	600	450	32	15	320										
K-30	KLY	7.8	9.0		6.3	600	350	37	15	320										
K-31	KLY	6.9	8.4		6.3	600	300	40	20	320										
K-32	KLY	5.5	7.9		6.3	600	300	50	20	320										
K-33	KLY		16.3		6.3	600	600	35	10	400										
K-34	KLY		12.1		6.3	600	550	35	10	400										
K-35	KLY		12.2		6.3	600	500	35	10	350										
K-41	KLY	1.3	2.5		6.3	850	350	60	80	250										
K-42	KLY	0.9	1.5		6.3	850	250	60	65	250										
K-48	KLY	3.4	4.4		6.3	850	400	70	100	180										
410R	KLY																			
700AD	MAG	0.6	20 P				12K	10A	40K						650					
706AU	MAG	3.1	3.1	P			22K	20	200K											
707A/B	KLY	2.4	3.5	C	6.3		250	100	275						20					
714AU	MAG	3.3	3.3	1 P			19K	20A	165K											
720AYE	MAG	2.8	2.8	/1 P			27K	65A	1M						2900					
723A/B	KLY	8.5	9.6	C	6.3		300	20	30	300					70					
725A	MAG	9.3	9.3	P			12K	10	44K											
726	KLY	2.9	3.2	C	6.3		300	20	170	300					30					

GROUP X, TRANSISTORS

TYPE NUMBER	KIND	MAXIMUM										TYPICAL			MAXIMUM			MINIMUM		TYP			MIN		MAXIMUM		FIG
		V _{CB0} V	V _{EBO} V	V _{CEO} V	I _C mA	I _E mA	I _{CB0} μA	P _C mA	K _θ mW/°C	T _J °C	CONNECTIONS	V _C V	I mA	h ₁₁ Ω	h ₁₂ 10 ⁻⁵	h ₂₂ μmho	h ₂₁	f _α MAX MHz	NF dB	K _M dB	C _{ob} pF	r _b r _{1C}	r _c r _{2C}				
P1A	GAP 20	20			5	5	30	50	10	70	E 10	1			3.3	0.90	0.1	30						1			
P1B	GAP 20	20			5	5	30	50	10	70	E 10	1			2.0	0.93	0.1	35					400	1			
P1D	GAP 20	20			5	5	15	50	10	70	E 10	1			2.0	0.94	0.1	18					600	1			
P1G	GAP 20	20			5	5	30	50	10	70	E 10	1			2.0	0.96	0.1	37					600	1			
P1I	GAP 20	20			5	5	20	50	10	70	E 10	1			2.0	0.96	1.6	35				40		1			
P1V	GAP 20	20			5	5	15	50	10	70	E 10	1			1.0	0.93	0.1	35					400	1			
P1YE	GAP 20	20			5	5	30	50	10	70	E 10	1			2.0	0.95	0.5	35				60	1K	1			
P1ZH	GAP 20	20			5	5	20	50	10	70	E 10	1			3.3	0.95	0.1	35				45	1K	1			
S1A	GPP 40	40			10	10		100			E 20	/1				1.0	0.5	19						7			
S1B	GPP 40	40			6	10		50			E 20	/1				1.2	0.5	22						7			
S1D	GPP 40	40			6	10		50			E 20	/1				1.2	5.0	22						7			
S1G	GPP 40	40			6	10		50			E 20	/1				1.2	1.5	22						7			
S1V	GPP 40	40			10	10		100			E 20	/1				1.2	1.5	19						7			
S1YE	GPP 40	40			6	10		50			E 20	/1				1.2	1.5	15						7			
P2A	GAP 100	100			10	10	200	250	10	60	C 50	5				0.90		17						1			
P2B	GAP 50	50			25	25	200	250	10	60	C 25	10				0.90		17						1			
S2A	GPP 30	30			10	10		100			E 10	/1				1.2	0.5							7			
S2B	GPP 20	20			6	10		50			E 10	/1				1.5	1.5							7			
S2G	GPP 20	20			6	10		50			E 10	/1				1.5	1.5							7			
S2V	GPP 20	20			6	10		50			E 10	/1				1.5	5.0							7			
P3A	GAP 50	50			50	150		500	S 3W	100	50	C 10	150			2.0	0.1	17						2			
P3B	GAP 50	50			50	250		250	S 3W	100	50	C 10	150			2.0	0.1	20						2			
P3V	GAP 50	50			50	450		250	S 3W	100	50	C 10	150			2.0	0.1	25						2			
S3A	GPP 40	40			10	10		100			E 20	/1				1.0	0.5	19						8			
S3B	GPP 40	40			6	10		50			E 20	/1				1.2	0.5	22						8			
S3D	GPP 40	40			6	10		50			E 20	/1				1.2	5.0	22						8			
S3G	GPP 40	40			6	10		50			E 20	/1				1.2	1.5	22						8			
S3V	GPP 40	40			10	10		100			E 20	/1				1.2	1.5	19						8			
S3YE	GPP 40	40			6	10		50			E 20	/1				1.2	10.0	15						8			
P4	G 55	55			2A			10W			E 20	/1															
P4A	GAP 60	60			5A			500	30W	500	90	C 5A	26		5.0	0.1	20							22			
P4B	GAP 70	60			5A			400	25W	500	90	C 5A	26	15	15	0.1	23							22			
P4D	GAP 60	50			5A			400	25W	500	90	C 5A	26	50	30	0.1	20							22			
P4G	GAP 60	50			5A			400	25W	500	90	C 5A	26	15	15	0.1	27							22			
P4L	GAP 50	50			3A			500	25W	500	50	C 2A	26	20	20	0.1	30							22			

GROUP X, TRANSISTORS

TYPE NUMBER	KIND	MAXIMUM										TYPICAL			MAXIMUM				MINIMUM		TYP		MIN		MAXIMUM		FIG
		V _{CBO} V	V _{EBO} V	V _{CEO} V	I _C mA	I _E mA	I _{CEO} μA	P _C mW	K _θ (mW/°C)	T _J °C	COMMON	V _C V	I mA	h ₁₁ Ω	h ₁₂ 10 ⁻⁵	h ₂₂ μmho	h ₂₁	f _α MHz	f _α MHz	NF dB	K _M dB	C _{ob} pF	r _b Ω	r _{1c} Ω	r _{2c} Ω		
P4V	GAP	40	35	20	5A		400	25W	500	90	C	5A		10		10	0.1		23						22		
S4A	GPP	30			6	10	100				E	10	/1			1.2	0.5								8		
S4B	GPP	20			6	10	50				E	10	/1			1.5	1.5								8		
S4G	GPP	20			6	10	50				E	10	/1			1.5	10.0								8		
S4V	GPP	20			6	10	50				E	10	/1			1.5	5.0								8		
P5A	GAP	10	20	10	10	10	30	25	1	75	E	2	1	36	500	3.3	0.93	0.3	12			80			4		
P5B	GAP	10	20	10	10	10	15	25	1	75	E	2	1	36	500	2.6	0.95	0.3	12			80			4		
P5D	GAP	10	20	10	10	10	30	25	1	75	E	2	1	36	500	2.6	0.95	0.3	7			80			4		
P5G	GAP	10	20	10	10	10	30	25	1	75	E	2	1	36	500	2.6	0.97	0.3	10			80			4		
P5V	GAP	10	20	10	10	10	15	25	1	75	E	2	1	36	500	2.6	0.97	0.3	15			80			4		
P5YE	GAP	10	20	10	10	10	15	25	1	75	E	2	1	36	500	2.6	0.96	0.3	18			80			4		
P6A	GAP	30	30	10	10	10	30	150	2	100	E	5	1	32	500	3.3	0.90	0.1	30	30		50			10		
P6B	GAP	30	30	15	10	10	15	150	2	100	E	5	1	32	60	2.0	0.90	0.5	30	34		50			10		
P6D	GAP	30	30	15	10	10	15	150	2	100	E	5	1	32	60	2.0	0.90	0.5	12	34		50			10		
P6G	GAP	30	30	10	10	10	15	150	2	100	E	5	1	32	60	3.3	0.97	1.0	30	37		50			10		
P6V	GAP	30	30	15	10	10	15	150	2	100	E	5	1	32	60	2.0	0.94	0.5	30	34		50			10.		
P7	GAP	13			45		30	45		50	E	2	1			0.97									4		
P8	GAN	20			10	10	30	150	2	100	E	5	1	34	500	3.3	10	0.1	15	32		65			10		
P8A	GAN	20			10	10	15	150	2	100	E	5	1	32	60	2.0	10	0.5	12	32		60			10		
P9	GAN	20			10	10	15	150	2	100	E	5	1	32	60	2.0	10	0.5	12	32		60			10		
P9A	GAN	20			10	10	15	150	2	100	E	5	1	32	60	2.5	15	1.0	5	32		60			10		
P10	GAN	20			10	10	15	150	2	100	E	5	1	32	60	2.5	15	1.0	5	32		60			10		
P10A	GAP	30	30	30	20		100	150	5	85	E	5	1	2.5	25		1.0					60			10		
P10B	GAP	30	30	30	20		100	150	5	85	E	5	1	2.5	25		1.0					60			10		
P11	GAN	20			10	10	15	150	2	100	E	5	1	32	60	2.5	25	1.6	5	32		60			10		
P11A	GAP	15	15	15	20		30	150	5	85	E	5	1	2.5	45		2.0					60			10		
P12	GAP		6		5	5	6	30	2	85	E	6	1	2.0	0.95		5.0					20			10		
P12A	GAP	6			5	5	6	30	1	70	E	6	1	2.0	0.95		5.0					20			10		
P13	GAP	30	15	20	10	10	15	150	2	100	E	5	1	500	2.5	12	0.5	33				50			10		
P13A	GAP	30	15	20	10	10	15	150	2	100	E	5	1	60	2.0	0.97	0.5	33				50			10		
P13B	GAP	30	15	20	10	10	10	150	2	100	E	5	1	60	2.5	20	0.5	12				50			10		
P14	GAP	30	15	20	10	10	15	150	2	100	E	5	1	500	2.5	20	1.0	33				50			10		
P14A	GAP	30	30	30	20	20	10	150	5	85	E	5	1	32	700	2.5	20	1.0				50			10		
P14B	GAP	30	30	30	20	20	10	150	5	85	E	5	1	32	500	2.5	30	1.0				50			10		
P15	GAP	30	15	20	10	10	15	150	2	100	E	5	1	500	2.5	30	1.6	33				50			10		

GROUP X, TRANSISTORS

TYPE NUMBER	KIND	MAXIMUM										TYPICAL			MINIMUM			TYP MIN			MAXIMUM		
		V _{CBO} V	V _{EBD} V	V _{CEO} V	I _C mA	I _E mA	I _{CBO} μA	P _C mA	K _θ mW/°C	T _j °C	COMMON	V _C V	I mA	h ₁₁ Ω	h ₁₂ 10 ⁻⁵	h ₂₂ μmho	h ₂₁	f _α MAX MHz	NF dB	K _M dB	C _{ob} pF	r _b r _{1c} Ω	FIG
P15A	GAP	30	15	20	20	20	10	150	5	85	E	5	1	32	500	2.5	50	2.0			50	150	10
P16	GAP	30	15	15	50	50	25	150	2	100						20	1.0				50	150	10
P16A	GAP	30	15	15	50	50	25	150	2	100						30	1.0				50	150	10
P16B	GAP	30	15	15	50	50	25	150	2	100						45	1.0				50	150	10
P17	G P	60		400			200	300							9	0.2							
P17A	G P	60		400			200	300							16	0.2							
P17B	G P	60		400			200	300							32	0.2							
P18	G P	100		400			200	300							9	0.2							
P18A	G P	100		400			200	300							16	0.2							
P18B	G P	100		400			200	300							32	0.2							
P19	GAP	20	20	6	5	5	6	30	1	90	E	5	1	33	2.0	0.95	5.0	5.0	5		20	150	10
P20	GAP	50			1	1	50	150			C		25		50	1.0							10
P21	GAP	50			1	1	50	150			C		25		20	1.0							10
P21A	GAP	70			1	1	50	150			C		25		50	1.0							10
P22	GAP	40					25	100		85					3.3	1.0							10
P23	GAP	35					25	100		85					3.3	2.0							10
P25	GAP	60		400			600	200		70	E	20	2		10	0.2					70	500	10
P25A	GAP	60		400			600	200		5					20	0.2			20				10
P25B	GAP	60		400			660	200		5					30	0.5			20				10
P26	GAP	100		400			600	200		70	E	35	2		10	0.2					50	500	10
P26A	GAP	100		400			600	200		5					20	0.2			20				10
P26B	GAP	100		400			600	200		5					30	0.5			20				10
P27	GAP	5		5	6	3	3	30	1	70					20	1.0	10				50	*6K	17
P27A	GAP	5		5	6	3	3	30	1	70					20	1.0	5				50	*6K	17
P28	GAP	5		5	6	3	3	30	1	70					20	5.0	5				50	*6K	17
P29	GAP	12		10	100		4	30	1	70					25	1.0					20		17
P29A	GAP	12		10	100		4	30	1	70					45	1.0					20		17
P30	GAP	12		10	100		4	30	1	70					80	1.0					20		17
P42A	GAP	15		150			200	5	70						30	1.0							17
P42B	GAP	15		150			200	5	70						45	1.0							17
P101	SAN	10		10	20	20	70N	150	2	120	E	5	1	100	200	3.3	90	0.2	15		150		10
P101A	SAN	10		10	20	20	70N	150	2	120	E	5	1	100	200	3.3	10	0.2	18		150		10
P101B	SAN	20		20	20	20	30	150	2	150	E	5	1	100	300	2.0	15	0.5	15		150		10
P102	SAN	10		10	20	20	70N	150	2	120	E	5	1	100	500	2.0	18	0.5	15		150		10
P103	SAN	10		10	20	20	70N	150	2	120	E	5	1	100	500	3.3	30	1.0	15		150		10

GROUP X, TRANSISTORS

TYPE NUMBER	KIND	MAXIMUM										TYPICAL			MAXIMUM			MINIMUM			TYP MIN			MAXIMUM		
		V _{CB0} V	V _{EB0} V	V _{CEO} V	I _C mA	I _E mA	I _{CB0} μA	P _C mW	K _θ mW/°C	T _J °C	COMMON	V _C V	I mA	h ₁₁ Ω	h ₁₂ 10 ⁻⁵	h ₂₂ μmho	h ₂₁	f _α MHz	f _{α MAX} MHz	NF dB	K _M	C _{ob} pF	r _b Ω	r _{ic} Ω	f _β MHz	
P104		100	45	60	20	20	500N	150	2	150	E	5	1	140	3.3	0.90	0.1					80	1K	10		
P105		SAP	45	45	30	20	500N	150	2	150	E	5	1	140	3.3	0.90	0.1					80	1K	10		
P106		SAP	45	45	15	30	500N	150	2	150	E	5	1	80	2.0	0.93	0.5					80	/2K	10		
P107		SAN	120				1	150							15		3.0									
GT108A		GAP	15				10	75	1	55	E	5	1		3.3	20	0.5					30	/3K	11		
GT108B		GAP	15				10	75	1	55	E	5	1		3.3	35	1.0					30	/3K	11		
GT108G		GAP	15				10	75	1	55	E	5	1		3.3	H1.1	1.0					30	/3K	11		
GT108V		GAP	15				10	75	1	55	E	5	1		3.3	60	1.0					30	/3K	11		
GT109A		GAP	15			6	20	30	/1	55	E	5	1		3.3	20	1.0					30		29		
GT109B		GAP	15			6	20	30	/1	55	E	5	1		3.3	35	1.0					30		29		
GT109G		GAP	15			6	20	30	/1	55	E	5	1		3.3	H1.1	1.0					30		29		
GT109V		GAP	15			6	20	30	/1	55	E	5	1		3.3	60	1.0					30		29		
P135		GAP	30				10	150		100		5	1		60	2.0	0.92					50		10		
P201		GAP	30	35	22	2A		400	1W	300	100													25		
P201A		GAP	30	35	22	2A		400	1W	300	100													25		
P202		GAP	55	35	30	2A		400	1W	300	100													25		
P203		GAP	60	45	30	2A		400	1W	300	100													25		
P207		GAP	45	20	40	25A		16M	4W	70	85													24		
P207A		GAP	45	20	40	25A		16M	4W	70	85													24		
P208		GAP	65	30	60	25A		25M	4W	70	85													24		
P208A		GAP	65	30	60	25A		25M	4W	70	85													24		
P209		P	45		=40	12A		8M	1500	43	85													23		
P209A		P	45		=40	12A		8M	1500	43	85													23		
P210		P	65		=60	12A		12M	1500	43	85													23		
P210A		P	65		=60	12A		12M	1500	43	85													23		
P211		GAP	50		500		500	50	750		85													26		
P212		GAP	70		500		500	50	750		85													26		
P212A		GAP	70		500		500	50	750		85													26		
P213		P	45		30	5A	1H	80	115H	314														0.2		
P214		P	60		45	5A	1H	300	10W	200														0.2		
P214A		P	60		45	5A	1H	300	10W	200														0.2		
P214B		P	60		45	5A	1H	150	115H	314														10.2		
P215		P	80		60	5A	1H	300	10W	200														0.2		
P216		N	40		30	75H	1H	500	30W	500														10.2		
P216A		N	40		30	75H	1H	500	30W	500														0.1		

GROUP I, TRANSISTORS

TYPE NUMBER	KIND	MAXIMUM										TYPICAL			MINIMUM			TYP		MIN		MAXIMUM		FIG	
		V _{CB0} V	V _{EBO} V	V _{CEO} V	I _C mA	I _E mA	I _{CEO} μA	P _C mA	K _θ mW/°C	T _j °C	COMMON	V _C V	I mA	h ₁₁ Ω	h ₁₂ 10 ⁻⁵	h ₂₂ μmho	h ₂₁	f _α MHz	NF dB	K _M dB	C _{ob} pF	r _b Ω	r _{ic} Ω		r _{eb} Ω
P217	N	60		45	75H	1H	500	30W	500	C	10	100				15	0.1								
P217A	N	60		45	75H	1H	500	30W	500	C	10	100				20	0.1								
P217B	N	60		45	75H	1H	500	20W	500	C	10	100				20	0.1								
2T301	SDN	20	3	20		10	100	150	2	120	10				3.0	30					10				27
2T301A	SDN	20	3	20		10	100	150	2	120	10				3.0	40					10				27
2T301B	SDN	30	3	30		10	100	150	2	120	10				3.0	10					10				27
2T301D	SDN	20	3	30		10	100	150	2	120	10				3.0	20					10				27
2T301G	SDN	20	3	30		10	100	150	2	120	10				3.0	10					10				27
2T301V	SDN	30	3	30		10	100	150	2	120	10				3.0	20					10				27
2T301YE	SDN	20	3	20		10	100	150	2	120	10				3.0	40					10				27
2T301ZH	SDN	20	3	20		10	100	150	2	120	10				3.0	80					10				27
P302	SAP			35	400		100	8W	70	150							0.2								20
P303	SAP			60	400		100	10W	70	150							0.1								20
P303A	SAP			60	400		100	10W	70	150							0.1								20
1T303A	GDN	12	2	10	15		8	100	3		5	5			15						10				13
1T303B	GDN	12	2	10	15		8	100	3		5	5			30						10				13
1T303D	GDN	12	2	10	15		8	100	3		5	5			30						10				13
1T303G	GDN	12	2	10	15		8	100	3		5	5			15						10				13
1T303V	GDN	12	2	10	15		8	100	3		5	5			60						10				13
1T303YE	GDN	12	2	10	15		8	100	3		5	5			60						10				13
P304	SAP			80	400		100	10W	70	150							/0.1								20
P306	N	60		60	400	1H	100	10W			10	100			7										
P306A	N	80		80	400	50	100	10W			20	50			5										
P307	N	80		80	30	4	3	250			20	4			15										
P308	N	120		120	15	4	3	250			20	4			15										
1T308A	GDP	30		12	50		5	150			1	10			30						8				12
1T308B	GDP	30		12	50		5	150			1	10			50						8				12
1T308G	GDP	30		12	50		5	150			1	10			80						8				12
1T308V	GDP	30		12	50		5	150			1	10			80						8				12
GT309A	GDP			10	10		5	50	1	70	5	1		5.0	20						10				9
GT309B	GDP			10	10		5	50	1	70	5	1		5.0	60						10				9
GT309D	GDP			10	10		5	50	1	70	5	1		5.0	20						10				9
GT309G	GDP			10	10		5	50	1	70	5	1		5.0	60						10				9
GT309V	GDP			10	10		5	50	1	70	5	1		5.0	20						10				9
GT309YE	GDP			10	10		5	50	1	70	5	1		5.0	60						10				9

GROUP X, TRANSISTORS

TYPE NUMBER	KIND	MAXIMUM										TYPICAL			MINIMUM			TYP MIN		MAXIMUM		FIG
		V _{CBO} V	V _{EBO} V	V _{CEO} V	I _C mA	I _E mA	I _{CBO} μA	P _C mA	K _θ mW/°C	T _J °C	COMMON	V _C V	I mA	h ₁₁ Ω	h ₁₂ 10 ⁻³	h ₂₂ μmho	h ₂₁	f _α MAX MHz	NF dB	K _M dB	C _{ob} pF	
GT310A	GDP	12		10	10	5	20	/1	75			38			20						4	29
GT310B	GDP	12		10	10	5	20	/1	75			38			60						4	29
GT310D	GDP	12		10	10	5	20	/1	75			38			20						5	29
GT310G	GDP	12		10	10	5	20	/1	75			38			60						5	29
GT310V	GDP	12		10	10	5	20	/1	75			38			20						5	29
GT310YE	GDP	12		10	10	5	20	/1	75			38			60						5	29
P314A	GAP	10	1			10	100		85						0.94	30					15	
P314B	GAP	10	1			5	100		85						0.94	60					10	
P314C	GAP	10	1			5	100		85						0.94	120					6	
P322	GDP	8			15	2	50		85					5.0	0.97	400					4	
P401	GDP	20	20	10	10	10	100	2	85	E	5	5			0.94	30					15	10
P402	GDP	20	20	10	10	5	100	2	85	E	5	5			0.94	60					10	10
P403	GDP	20	20	10	10	5	100	2	85	E	5	5			0.94	*12 H					10	10
P403A	GDP	20	20	10	10	5	100	2	85	E	5	5			0.97	*12. H					10	10
1T403A	GAP	45	20	30	12H	50		70	85						20							28
1T403B	GAP	45	20	30	12H	50		70	85						50							28
1T403D	GAP	60	30	45	12H	50		70	85						50							28
1T403G	GAP	60	20	45	12H	50		70	85						50							28
1T403I	GAP	80	20	60	12H	70		70	85						50							28
1T403V	GAP	60	20	45	12H	50		80	85						20							28
1T403YE	GAP	60	20	45	12H	50		80	85						30							28
1T403ZH	GAP	80	20	60	12H	70		70	85						20							28
P404	GSP	5	5	/5	5	5	10	/1	85	E	3	/1			7.0	0.93	10				5	5
P404A	GSP	5	5	/5	5	2	10	/1	85	E	3	/1			7.0	0.93	10				5	5
P405	GSP	5	5	/5	5	5	10	/1	85	E	3	/1			7.0	0.95	30				5	5
P405A	GSP	5	5	/5	5	2	10	/1	85	E	3	/1			7.0	0.95	30				5	5
P406	GAP	6	6	6	5	5	30	2	85		6	1			2.0	0.95	10				20	150 17
P407	GAP	6	6	6	5	5	30	2	85		6	1			2.0	0.95	20				20	150 17
P408	G P	20	20	6	5	5	6	30	1	90	E	5	1	33							5	20 150 3
P409	G P	20	20	6	5	5	6	30	1	90	E	5	1	33							5	20 150 3
P410	GDP	6	6	6	20	2	100	2	85	E	5	5	10	120	1.0	0.97	*H2.0				4	6
P410A	GDP	6	6	6	20	2	100	2	85	E	5	5	10	120	1.0	0.99	*H4.0				4	6
P411	GDP	6	6	6	20	2	100	2	85	E	5	5	10	120	1.0	0.97	400				4	6
P411A	GDP	6	6	6	20	2	100	2	85	E	5	5	10	120	1.0	0.99	400				4	6
P414	GDP	10	1	10	10	5	100	2	75						5.0	0.25	*60				10	*1K 10

GROUP X, TRANSISTORS

TYPE NUMBER	KIND	MAXIMUM										TYPICAL			MAXIMUM			MINIMUM		TYP		MIN		MAXIMUM	
		V _{CBO} V	V _{EBO} V	V _{CE0} V	I _C mA	I _E mA	I _{CBO} μA	P _C mW	K _θ mW/°C	T _J °C	COMMON	V _C V	I mA	h ₁₁ Ω	h ₁₂ 10 ⁻⁵	h ₂₂ μmho	h ₂₁	f _α MHz	NF dB	K _M dB	C _{ob} pF	r _b Ω	r _c Ω	FIG	
P414A	GDP	10	1	10	10	5	100	2	75						5.0	60	*60				10	*1K	10	10	
P414B	GDP	10	1	10	10	5	100	2	75						5.0	1H	*60				10	*1K	10	10	
P415	GDP	10	1	10	10	5	100	2	75						5.0	25	*H1.2				10	*5H	10	10	
P415A	GDP	10	1	10	10	5	100	2	75						5.0	60	*H1.2				10	*5H	10	10	
P415B	GDP	10	1	10	10	5	100	2	75						5.0	1H	*H1.2				10	*5H	10	10	
P416	GDP		3	15	15	3	100	2	70	C					5.0	25	*H1.2				8				
P416A	GDP		3	15	15	3	100	2	70	C					5.0	50	H1.2				8				
P416B	GDP		3	15	15	3	100	2	70	C					5.0	1H					8				
P416V	P		15			2	100	2	C							H1.2									
P417	P		10			3	50	2	C							24	200								
P417A	P		10			3	50	2	C							65	200								
P418	P		10			3	50	2	C							24	400								
P418A	P		10			3	50	2	C							65	400								
P418B	P		10			10	3	50	2	C						24	700								
P418V	P		10			10	3	50	2	C						65	700								
P420	GDP	40		12	25	10	100								6.0	12	*30				20	*5K	10	10	
P421	GDP	40		12	25	10	100								5.0	15	*30				15	*3K	10	10	
P422	GDP	40		12	25	5	100								5.0	30	*60				10	*1K	10	10	
P422A	GDP	40		12	25	5	100								5.0	15	*60				10	*1K	10	10	
P423	GDP	40		12	25	5	100								5.0	30	*H1.2								
P423A	GDP	40		12	25	5	100								5.0	15	*H1.2								
P501	SDN	20	1	20		10	100	150	1	150	E	10	3		3.0	9	*1.0				10				
P501A	SDN	20	1	20		10	100	150	1	150	E	10	3		3.0	19	*1.0				10				
P502	SDN	20	1	20		10	100	150	1	150	E	10	3		3.0	9	*3.0				10				
P502A	SDN	20	1	20		10	100	150	1	150	E	10	3		3.0	19	*3.0				10				
P502B	SDN	20	1	20		10	100	150	1	150	E	10	3		3.0	9	*3.0				10				
P502V	SDN	20	1	20		10	100	150	1	150	E	10	3		3.0	19	*3.0				10				
P503	SDN	20	1	20		10	100	150	1	150	E	10	3		3.0	9	*6.0				10				
P503A	SDN	20	1	20		10	100	150	1	150	E	10	3		3.0	19	*6.0				10				
P504	SDN	30	2	30	10	2	150	2	120						2.0	10					7				
P504A	SDN	30	2	30	10	2	150	2	120						2.0	25					7				
P505	SDN	20	2	20	10	2	150	2	120						2.0	40					7	*1K	14	14	
P505A	SDN	20	2	20	10	2	150	2	120						2.0	20					7	*1K	14	14	
P601	GDP	25	/1	25	1A	200	1W		85						20	20					10			26	
P601A	GDP	30	/1	30	1A	100	1W		85						40	40					10			26	

GROUP X, TRANSISTORS

TYPE NUMBER	KIND	MAXIMUM										TYPICAL			MINIMUM		TYP		MIN		MAXIMUM		FIG	
		V _{CBO} V	V _{EBO} V	V _{CEO} V	I _C mA	I _E mA	I _{CBO} μA	P _C mW	K _θ mW/°C	T _J °C	NONNO	V _C V	I mA	h ₁₁ Ω	h ₁₂ 10 ⁻⁵	h ₂₂ μmho	h ₂₁	f _α * f _{MAX} MHz	NF dB	K _M dB	C _{ob} pF	r _b r _{1c} r _{2c}		
P601B	GDP	30	/1	25	1A	130	1W		85							80			10				26	
P602	GDP	30	/1	30	1A	100	1W		85							40			10				26	
P602A	GDP	25	/1	25	1A	130	1W		85							80			10				26	
P604	G P		15	45	200		400		50							20							15	
P604A	G P		15	45	200		400		50							10							15	
P604B	G P		15	45	200		400		50							40							15	
P605	G P	35		35	500	2	3W	30	70	C			500		20						130	*5H	14	
P605A	G P	35		35	500	2	3W	30	70	C			500		40						130	*5H	14	
P606	G P	25		35	500	2	3W	30	70	C			500		20						130	*5H	14	
P606A	GDP	35		25	15H	2M	500	500	85	C					50						130		26	
P607	G P	15	1		200	2000	1500			C	10	100			20							40	*2H	18
P607A	G P	15	1		200	2000	1500			C	10	100			60							40	*2H	18
P608	G P	15	1		200	2000	1500			C	10	100			20							30	*2H	18
P608A	G P	15	1		200	2000	1500			C	10	100			60							30	*2H	18
P609	G P	15	1		200	2000	1500			C	10	100			20							30	*2H	18
P609A	G P	15	1		200	2000	1500			C	10	100			60							30	*2H	18
P701	SAN			40	500	7H	100	10W	150						10									
P701A	SAN			60	500	7H	100	10W	150						10									
P702	SAN	60	3		2A	5000	4000		35	150	C	10	1A		25								21	
P702A	SAN	60	3		2A	2500	4000		35	150	C	10	1A		10								21	

GROUP XI, DIODES—RECTIFIERS

TYPE NUMBER	TYPE	MAXIMUM			MAXIMUM @ 25 °C			MAXIMUM			f _{Max} MHz	FIG
		I _F @ 25 mA	T _{Opr} °C	I _S @ 25°C A	PIV V	E _F * MIN V	I _F mA	I _F @ μA	E _r @ T°C V	°C		
D1A	GEP	16	70		20	1.0	2	250	10	20	150	1
D1B	GEP	16	70		30	1.0	1	250	25	20	150	1
D1D	GEP	16	70		75	1.0	2	250	75	20	150	1
D1G	GEP	16	70		50	1.0	5	250	50	20	150	1
D1V	GEP	25	70		30	1.0	8	250	25	20	150	1
D1YE	GEP	12	70		100	1.0	1	250	100	20	150	1
D12H	GEP	12	70		100	1.0	5	250	100	20	150	1
DG-TS1	* GEP	16	70	/1	50	*1.0	2	1000	50	20		6
D2A	GEP	50	70		7	1.0	50	250	7	20	150	6
D2B	GEP	16	70		10	1.0	10	250	10	20	150	6
D2D	GEP	16	70		50	1.0	10	250	50	20	150	6
D2G	GEP	16	70		50	1.0	5	250	50	20	150	6
D2I	GEP	16	70		150	*1.0	2	250	150	20	150	4
D2K	* GEP	16	70		100	1.0	5	800	100	20		4
D2M	* GEP	16	70		100	1.0	5	250	100	20		4
D2N	* GEP	16	70		150	1.0	5	800	150	20		4
D2P	* GEP	16	70		150	1.0	5	250	150	20		4
42R	* GEP	16	70		200	1.0	5	250	200	20		4
D2V	GEP	25	70		30	1.0	10	250	30	20	150	4
D2YE	GEP	16	70		100	1.0	10	250	100	20	150	4
D2ZH	GEP	8	70		150	1.0	10	250	150	20	150	4
DG-TS2	* GEP	16	70	/1	75	*1.0	4	500	50	20		6
DG-TS3	* GEP	25			50	1.0	2	100	50	20		6
DG-TS4	* GEP	16	70	/1	100	*1.0	2	800	75	20		6
DG-TS5	* GEP	16	70	/1	100	*1.0	1	250	75	20		6
DG-TS6	* GEP	16	70	/1	125	*1.0	1	800	100	20		6
D7A	GEP	300	70		50	0.5	300	100	50	20		11
D7B	GEP	300	70		100	0.5	300	100	100	20	50K	11
D7D	GEP	300	70		300	0.5	300	100	300	20	50K	11
D7G	GEP	300	70		200	0.5	300	100	200	20	50K	11
D7V	GEP	300	70		150	0.5	300	100	150	20	50K	11
D7YE	GEP	300	70		350	0.5	300	100	350	20	50K	11
D7ZH	GEP	300	70		400	0.5	300	100	400	20	50K	11
DG-TS7	* GEP	16	70	/1	125	*1.0	1	250	100	20		6
DG-TS8	* GEP	25	70	/1	50	*1.0	10	500	30	20		6
D9A	GEP	25	70		10	1.0	10	250	10	20	40	1
D9B	GEP	40	70		10	1.0	90	250	10	20	40	1
D9D	GEP	30	70		30	1.0	60	250	30	20	40	1
D9G	GEP	25	70		30	1.0	30	250	30	20	40	1
D9I	GEP	30	70		30	1.0	30	120	30	20	40	1

GROUP XI, DIODES — RECTIFIERS

TYPE NUMBER	TYPE	MAXIMUM			MAXIMUM @ 25 °C			MAXIMUM			f _{Max} MHz	FIG
		I _F @ 25 mA	T _{Opr} °C	I _S @ 25°C A	PIV V	E _F * MIN V E _F	I _F mA	I _F μA	E _r V	T _c °C		
D9K	GEP	30	70		30	1.0	60	60	30	20	40	1
D9L	GEP	15	70		100	1.0	30	250	100	20	40	1
D9M	GEP	30	70		30	1.0	60	250	50	20	40	1
D9V	GEP	20	70		30	1.0	10	250	30	20	40	1
D9YE	GEP	20	70		50	1.0	30	250	50	20	40	1
D92H	GEP	15	70		100	1.0	10	250	100	20	40	1
DG-TS9	GEP	50	70	/1	45	*1.0	10	100	10	20		6
D10	GEP	50	70		20	1.5	3	100	10	20	150	4
D10A	GEP	50	70		20	1.5	5	200	10	20	150	4
D10B	GEP	50	70		20	1.5	8	200	10	20	150	4
DGTS10	GEP	50	70	/1	45	*1.0	5	60	10	20	150	6
D11	GEP	60	70		30	1.0	100	250	30	20	150	4
D12	GEP	60	70		50	1.0	100	250	50	20	150	4
D12A	GEP	70	70		50	1.0	100	250	50	20	150	4
DGTS12	GEP	16	70		30	1.0					150	6
D13	GEP	60	70		75	1.0	100	250	75	20	150	4
DGTS13	GEP	16	70		30	1.0						6
D14	GEP	60	70		100	1.0	100	250	100	20	150	4
D14A	GEP	60	70		100	1.0	100	250	100	20	150	4
DGTS14	GEP	16	70		50	1.0						6
D15	GEP				30	1.0	15	300	30		300	
DGTS15	GEP	50	70		150	1.0	1	800	150	20		6
D16	GEP				50	1.0	5	500	50		300	
D16A	GEP				50	1.0	10	500	50		300	
DGTS16	GEP	50	70		150	1.0	1	250	150	20		6
D17	GEP				100	1.0	4	400	100		300	
DGTS17	* GEP	50	70		200	*1.0	1	800	200	20		6
D18	GEP	20	70		20	1.0	20	50	20	20		2
D19	GEP	45	70		40	1.0	45	100	40	50		1
D19A	GEP	60	70		20	1.0	60	100	20	50		1
D19B	GEP	45	70		20	1.0	45	100	20	50		1
D20	GEP	20	70		10	1.0	10	50	10	20		2
D21	GEP	16	70		150	1.0	5	250	100	20	150	4
DGTS21	GEA	300	70		50	0.5	300	300	50	20	50K	3
DGTS22	GEA	300	70		100	0.5	300	300	100	20	50K	3
DGTS23	GEA	300	70		150	0.5	300	300	150	20	50K	3
DGTS24	GEA	300	70		200	0.5	300	300	200	20	50K	3
DGTS25	GEA	100	70		300	0.3	100	300	300	20	50K	3
DGTS26	GEA	100	70		350	0.3	100	300	350	20	50K	3
DGTS27	GEA	100	70		400	0.3	100	300	400	20	50K	3

GROUP XI, DIODES — RECTIFIERS

TYPE NUMBER	TYPE	MAXIMUM			MAXIMUM @ 25 °C			MAXIMUM			f _{Max} MHz	FIG
		I _F @25 mA	T _{Opr} °C	I _S @25°C A	PIV V	E _F * MIN V	I _F mA	I _F @ μA	E _r @ V	T°C		
D101	SIP	50	150	/1	100	2.0	2	100	75	125	600	2
D101A	SIP	75	150	/1	100	1.0	1	75	75	125	600	2
D102	SIP	50	150	/1	75	2.0	2	100	50	125	600	2
D102A	SIP	75	150	/1	75	1.0	1	100	50	125	600	2
D103	SIP	50	150	/1	30	2.0	2	100	30	125	600	2
D103A	SIP	75	150	/1	30	1.0	1	100	30	125	600	2
D104	SIP	30	150	/1	100	2.0	2	150	75	125	600	2
D104A	SIP	30	150	/1	100	1.0	1	150	75	125	600	2
D105	SIP	30	150	/1	75	2.0	2	100	50	125	600	2
D105A	SIP	30	150	/1	75	1.0	1	100	50	125	600	2
D106	SIP	30	150	/1	30	2.0	2	100	30	125	600	2
D106A	SIP	30	150	/1	30	1.0	1	50	30	125	600	2
D107	SIP	10	125		10	1.0	10	/1	10	50		2
D107A	SIP	10	125		10	1.0	10	10	10	125		2
D108	SIP	10	125		30	1.0	10	35	30	25		2
D109	SIP	10	125		50	1.0	10	20	30	25		2
D201A	SI	200	125		25	1.5						
D201B	SI	200	125		50	1.5						
D201D	SI	400	125		100	2.0						
D201G	SI	200	125		100	1.5						
D201TS	SI	400	125		200	2.0						
D201V	SI	400	125		50	2.0						
D201YE	SI	200	125		200	2.0						
D201ZH	SI	400	125		200	2.0	400	500	200			
D202	SIA	400	125		100	1.0	400	500	100	125	0.1	13
D203	SIA	400	125		200	1.0	400	500	200	125	0.1	13
D204	SIA	400	125		300	1.0	400	500	300	125	0.1	13
D205	SIA	400	125		400	1.0	400	500	400	125	0.1	13
D206	SIA	100	125		100	1.0	100	100	100	125	0.1	10
D207	SIA	100	125		200	1.0	100	100	200	125	0.1	10
D208	SIA	100	125		300	1.0	100	100	300	125	0.1	10
D209	SIA	100	125		400	1.0	100	100	400	125	0.1	10
D210	SIA	100	125		500	1.0	100	100	500	125	0.1	10
D211	SIA	100	125		600	1.0	100	100	600	125	0.1	10
D214	SIA	5A	125		100	1.0	5A	3000	100	125		16
D214A	SIA	10A	125		100	1.0	10A	3000	100	125		16
D214B	SIA	2A	125		100	1.0	2000	3000	100	20	1K	16
D215	SIA	5A	125		200	1.0	5A	3000	200	125		16
D215A	SIA	10A	125		200	1.0	10A	3000	200	125		16
D215B	SIA	2A	125		200	1.0	2000	3000	200	20	1K	16

GROUP XI, DIODES—RECTIFIERS

TYPE NUMBER	TYPE	MAXIMUM			MAXIMUM @ 25 °C			MAXIMUM			f _{Max} MHz	FIG
		I _F @ 25 mA	T _{Opr} °C	I _S @ 25°C A	PIV V	E _F → MIN V	E _F mA	I _F μA	E _r V	@ T°C		
D217	SIA	100	125		800	0.5	100	50	800	20	1K	9
D218	SIA	100	125		1000	0.5	100	50	1000	20	1K	9
D219A	SIA	50	125	/1	70	1.0	50	30	70	100		2
D220	SIA	50	125	/1	50	1.5	50	20	50	100		2
D220A	SIA	50	125	/1	70	1.5	50	30	70	100		2
D220B	SIA	50	125	/1	100	1.5	50	40	100	100		2
D221	SIA	400	125		400	1.0	400	500	400	125	3K	13
D222	SIA	400	125		600	1.0	400	500	600	125	3K	13
D223	SIA	50	125	/1	50	1.0	50	50	50	125		2
D223A	SIA	50	125	/1	100	1.0	50	50	100	125		2
D223B	SIA	50	125	/1	150	1.0	50	50	150	125		2
D224	SIA	5A	125		50	1.0	5000	3000	50	20		14
D224A	SIA	10A	125		50	1.0	10A	3000	50	20		14
D224B	SIA	2A	125		50	1.0	2000	3000	50	20		14
D225	SIA	30	125		5	1.0	30		5	20		8
D226	SIA	300	125		400	1.0	300	30	400	20		9
D226A	SIA	300	125		300	1.0	300	30	300	20		9
D226D	SIA	300	125		100	1.0	300	300	100	80		9
D226G	SIA	300	125		200	1.0	300	300	200	80		9
D226V	SIA	300	125		300	1.0	300	300	300	80		9
D226YF	SIA	300	125		400	1.0	300	300	400	80		9
D229A	SIA	400	125		200	1.0	400	50	200	20		15
D229B	SIA	400	125		400	1.0	400	50	400	20		15
D230A	SIA	300	125		200	1.0	300	50	200	20		9
D230B	SIA	300	125		400	1.0	300	50	400	20		9
D231(P)	SIA	10A	130		300	1.0	10A	3000	300	130		14
D231A(P)	SIA	10A	130		300	1.0	10A	3000	300	130		14
D231B(P)	SIA	10A	130		300	1.0	10A	3000	300	130		14
D232(P)	SIA	10A	130		400	1.0	10A	3000	400	130		14
D232A(P)	SIA	10A	130		400	1.0	10A	3000	400	130		14
D232R(P)	SIA	10A	130		400	1.0	10A	3000	400	130		14
D233(P)	SIA	10A	130		500	1.0	10A	3000	500	130		14
D233A	SIA	10A	125		500	1.5	10A	3000	500	20		14
D233B(P)	SIA	10A	130		500	1.0	10A	3000	500	130		14
D234B(P)	SIA	10A	130		600	1.0	10A	3000	600	130		14
D242(P)	SI	10A	130		100	1.25		3M	100	130	K1.0	14
D242A(P)	SI	10A	130		100	1.0		3M	100	130	K1.0	14
D242B(P)	SI	5A	130		100	1.5		3M	100	130	K1.0	14
D243(P)	SI	10A	130		200	1.25		3M	200	130	K1.0	14
D243A(P)	SI	10A	130		200	1.0		3M	200	130	K1.0	14

GROUP XI, DIODES—RECTIFIERS

TYPE NUMBER	TYPE	MAXIMUM		MAXIMUM @ 25 °C			MAXIMUM			f _{Mox} MHz	FIG	
		I _F @ 25 mA	T _{Opr} °C	I _S @ 25°C A	PIV V	E _F MIN V	I _F mA	I _F @ μA	E _r @ V			T _° °C
D243B(P)	SI	5A	130		200	1.5		3M	200	130	K1.0	14
D244 (P)	SI	10A	130		50	1.25		3M	50	130	K1.0	14
D244A(P)	SI	10A	130		50	1.0		3M	50	130	K1.0	14
D244B(P)	SI	5A	130		50	1.5		3M	50	130	K1.0	14
D245	SI	10A	130		300	1.25		3M	300	130	K1.0	14
D245A	SI	10A	130		300	1.0		3M	300	130	K1.0	14
D245B	SI	5A	130		300	1.5		3M	300	130	K1.0	14
D246	SI	10A	130		400	1.25		3M	400	130	K1.0	14
D246B	SI	5A	130		400	1.5		3M	400	130	K1.0	14
D247	SI	10A	130		500	1.25		3M	500	130	K1.0	14
D247B	SI	5A	130		500	1.5		3M	500	130	K1.0	14
D248B	SI	5A	130		600	1.5		3M	600	130	K1.0	14
D302	GEA	1A	70		200	0.25	1A	1000	200	20	50K	16
D303	GEA	3A	70		150	0.3	3A	1000	150	20	50K	16
D304	GEA	5A	70		100	0.3	5A	3000	100	20	50K	16
D305	GEA	10A	70		50	0.35	10A	3000	50	20	50K	16
D310	GEA	500	70		20			100	20	70		7
KTS401A	SI	400	70	5A	500	2.5	300	100	500	25		21
KTS401B	SI	500	70	5A	500	2.5	400	100	500	25		22
2D503A	SI	20	120		30	1.0		4	30			1
2D503B	SI	20	120		30	1.2		4	30			1
D1001	GE	100	80		2000	6.5	100	150	2000		/0.1	17
D1001A	GE	100	80		1000	3.5	100	150	1000		/0.1	17
D1002	GE	300	80		2000	7.5	300	300	2000		/0.1	17
D1002A	GE	300	80		1000	4.0	300	300	1000		/0.1	17
D1003A	GE	300	80		500	2.0	300	300	500		/0.1	17
D1004	SIA	100	125		2000	4.0	100	100	2000	20		20A
D1005A	SIA	50	125		4000	4.0	50	100	4000	20		20A
D1005B	SIA	100	125		4000	6.0	100	100	4000	20		20B
D1006	SIA	100	125		6000	6.0	100	100	6000	20		20B
D1007	SIA	75	125		8000	6.0	100	100	8000	20		20B
D1008	SIA	50	125		10K	6.0	100	100	10K	20		20B
D1009	SIA	100	125		2000	7.0	100	100	2000	20		18A
D1009A	SIA	100	125		1000	3.5	300	100	1000	20		19
D1010	SIA	300	125		2000	1.1	300	100	2000	20		18B
D1010A	SIA	300	125		1000	5.5	300	100	1000	20		19
D1011A	SIA	300	125		500	2.5	300	100	500	20		19
D1602A	GE	300	70		200	1.0	300	1	200			
D1602B	GE	300	70		300	1.0	300	1	300			
D1602V	GE	300	70		400	1.0	300	1	400			

GROUP XI-A, DIODES-SWITCHING

TYPE NUMBER	KIND	TYPE	SWITCH RANGE		MAXIMUM CURRENT				SWITCH TIME		CAPACITY pF	FIG
			MAX V	MIN V	SWITCH OFF mA	ON mA	REVRS. mA	LEAKAGE mA	OFF μ s	ON μ s		
D227-A	SWI	SI4	10	20	15	5	1	100	10	0.5	100	13
D227-B	SWI	SI4	14	28	15	5	1	100	10	0.5	100	13
D227-D	SWI	SI4	40	80	15	5	1	100	10	0.5	100	13
D227-G	SWI	SI4	28	56	15	5	1	100	10	0.5	100	13
D227-I	SWI	SI4	100	200	15	5	1	100	10	0.5	100	13
D227-V	SWI	SI4	20	40	15	5	1	100	10	0.5	100	13
D227YE	SWI	SI4	56	112	15	5	1	100	10	0.5	100	13
D227-ZH	SWI	SI4	80	160	15	5	1	100	10	0.5	100	13
D228-A	SWI	SI4	10	20	15	1	1	60	5	0.1	80	9
D228-B	SWI	SI4	14	28	15	1	1	60	5	0.1	80	9
D228-D	SWI	SI4	40	80	15	1	1	60	5	0.1	80	9
D228-G	SWI	SI4	28	56	15	1	1	60	5	0.1	80	9
D228-I	SWI	SI4	100	200	15	1	1	60	5	0.1	80	9
D228-V	SWI	SI4	20	40	15	1	1	60	5	0.1	80	9
D228YE	SWI	SI4	56	112	15	1	1	60	5	0.1	80	9
D228-ZH	SWI	SI4	80	160	15	1	1	60	5	0.1	80	9

GROUP XI-B, DIODES-TUNNEL

TYPE NUMBER	KIND	TYPE	MAXIMUM		MIN V_p mV	V_{FM}		CAP pF	FIG
			I_p mA	I_p/I_v		MAX mV	MIN mV		
3I-301A	TUN	GAS	2	8	180	650		12	23
3I-301B	TUN	GAS	5	8	180	850	1150	25	23
3I-301G	TUN	GAS	10	8	180	800		50	23
3I-301V	TUN	GAS	5	8	180	1000	1300	25	23
1I-302A	TUN	GE	2.3	4.5	60		400	80	23
1I-302B	TUN	GE	5.8	4.5	60		400	150	23
1I-302G	TUN	GE	17	4.5	60		400	200	23
1I-302V	TUN	GE	11.5	4.5	60		400	180	23

GROUP XI-C, DIODES-SWITCH CONTROL

TYPE NUMBER	KIND	TYPE	VOLTAGE		MAXIMUM CURRENTS				POWER		TIME MAX		TEMP		FIG
			SWITCH MAX V	RES. MIN V	CONT. MAX mA	SWITCH OFF mA	ON A	LEAK mA	MAX W	K_θ mW/°C	OFF μ s	ON μ s	MAX (-) $^{\circ}$ C	MIN (+) $^{\circ}$ C	
D235A	CON	SI	40	2	20	100	2	1	4	120	5	35	60	125	15
D235B	CON	SI	100	2	20	100	2	1	4	120	5	35	60	125	15
D235G	CON	SI	100	2	20	100	2	1	4	120	5	35	60	125	15
D235V	CON	SI	40	2	20	100	2	1	4	120	5	35	60	125	15
D238A	CON	SI	50	2			10		20	330	10	35	50	100	32
D238B	CON	SI	100	2			10		20	330	10	35	50	100	32
D238D	CON	SI	100	2			10		20	330	10	35	50	100	32
D238G	CON	SI	50	2			10		20	330	10	35	50	100	32
D238V	CON	SI	150	2			10		20	330	10	35	50	100	32
D238YE	CON	SI	150	2			10		20	330	10	35	50	100	32

GROUP XI-D, DIODES-VARACTORS

TYPE NUMBER	KIND	TYPE	MAXIMUM		CAPACITY @ 4V				Q	POWER		TEMP		FIG
			VOLTS V	I_R μ A	MIN pF	MAX pF	TC	EXP (-)		MAX mW	MIN (-) $^{\circ}$ C	MAX (+) $^{\circ}$ C		
D901A	VAR	SI	80	1	22	32	5	4	25	250	60	125	7	
D901B	VAR	SI	45	1	22	32	5	4	30	250	60	125	7	
D901D	VAR	SI	80	1	34	44	5	4	25	250	60	125	7	
D901G	VAR	SI	45	1	28	38	5	4	30	250	60	125	7	
D901V	VAR	SI	80	1	28	38	5	4	25	250	60	125	7	
D901YE	VAR	SI	45	1	34	44	5	4	30	250	60	125	7	

GROUP XII, DIODES—POWER RECTIFIERS

TYPE NUMBER	KIND	TYPE	MAXIMUM			MAXIMUM E_R IN VOLTS														COOLING			
			OPR TEMP °C	I_f Amp	E_f V	I_r mA	AVAILABLE FOR FOLLOWING SUBCLASSES														KIND	RATE	RADIATOR
							15	30	45	50	55	70	80	100	110	150	2H	3H	4H	5H			
VG-5	POW	GE	75	5	0.5					X	X		X	X		X	X	X		AN			
VG-5	POW	GE	75	10	0.5					X	X		X	X		X				AF	10M		
VG-10	POW	GE	75	10	0.5					X										AN			
VG-10-30	POW	GE	75	20	0.5	10				X										AF	10M		
VG-10-45	POW	GE	75	20	0.5	8					X									AF	10M		
VG-10-55	POW	GE	75	20	0.5	6						X								AF	10M		
VG-10-80	POW	GE	75	20	0.5	5							X							AF	10M		
VG-10-110	POW	GE	75	20	0.5	4									X					AF	10M		
VG-10-150	POW	GE	75	20	0.5	3										X				AF	10M		
VG-30	POW	GE	75	30	0.5					X	X				X	X				AF	10M		
VG-50	POW	GE	75	50	0.5	40	X	X												AF	10M		
VG-50	POW	GE	75	50	0.5	30			X		X									AF	10M		
VG-50	POW	GE	75	50	0.5	20						X			X	X				AF	10M		
VG-100	POW	GE	75	100	0.5				X	X					X					AF	10M		
VG-200	POW	GE	75	200	0.6	100	X	X	X	X	X				X	X				W	4L		
VG-500	POW	GE	75	500	0.6				X	X										W	4L		
VG-1000	POW	GE	75	1000	0.8				X	X										W	4L		
VK-10	POW	SI	200	10	0.9					X				X	X	X	X	X	X	X	AN		
VK-10	POW	SI	200	20	0.9					X				X	X	X	X	X	X		AF	15M	
VK-25	POW	SI	200	25	0.9					X				X	X	X	X	X	X		AF	5M	
VK-25	POW	SI	200	50	0.9					X				X	X	X	X	X	X		AF	15M	
VK-50	POW	SI	200	50	0.9					X				X	X	X	X	X	X		AF	5M	
VK-50	POW	SI	200	100	0.9					X				X	X	X	X	X	X		AF	15M	
VK-100	POW	SI	200	100	0.9					X				X	X	X	X	X	X		AF	10M	
VK-100	POW	SI	200	150	0.9					X				X	X	X	X	X	X		AF	15M	
VK-200	POW	SI	200	200	0.9					X				X	X	X	X	X		AF	15M	X	
VK-200	POW	SI	200	200	0.9					X				X	X	X	X	X		W	4L	X	
VK-200	POW	SI	200	500	0.9					X				X	X	X				W	4L	X	
VK-1000	POW	SI	200	1000	0.9					X				X	X					W	4L	X	

GROUP XII-A, SILICON CONTROLLED RECTIFIERS

TYPE NUMBER	KIND	TYPE	MAX. FORWARD CURRENT					PIV v	MAXIMUM					I _R mA	FIG
			NONE	AIR-COOL		WATER-COOL			POWER		GATE PULSE				
				WITH RAD	FORCED AIR RAD	2L/m	5L/m		W	GATE W	V	A	WIDTH μs		
VKU-10-0.25	SCR	SI4	1	5	10		50	20	1.25	20	1.0	20	20	24	
VKU-10-0.5	SCR	SI4	1	5	10		100	20	1.25	20	1.0	20	20	24	
VKU-10-0.75	SCR	SI4	1	5	10		150	20	1.25	20	1.0	20	20	24	
VKU-10-1.0	SCR	SI4	1	5	10		200	20	1.25	20	1.0	20	20	24	
VKU-10-1.5	SCR	SI4	1	5	10		250	20	1.25	20	1.0	20	20	24	
VKU-10-2.0	SCR	SI4	1	5	10		400	20	1.25	20	1.0	20	20	24	
VKU-10-2.5	SCR	SI4	1	5	10		500	20	1.25	20	1.0	20	20	24	
VKU-10-3.0	SCR	SI4	1	5	10		600	20	1.25	20	1.0	20	20	24	
VKU-20-0.25	SCR	SI4	3	10	20		50	20	1.25	20	1.0	20	20	25	
VKU-20-0.5	SCR	SI4	3	10	20		100	20	1.25	20	1.0	20	20	25	
VKU-20-0.75	SCR	SI4	3	10	20		150	20	1.25	20	1.0	20	20	25	
VKU-20-1.0	SCR	SI4	3	10	20		200	20	1.25	20	1.0	20	20	25	
VKU-20-1.5	SCR	SI4	3	10	20		250	20	1.25	20	1.0	20	20	25	
VKU-20-2.0	SCR	SI4	3	10	20		400	20	1.25	20	1.0	20	20	25	
VKU-20-2.5	SCR	SI4	3	10	20		500	20	1.25	20	1.0	20	20	25	
VKU-20-3.0	SCR	SI4	3	10	20		600	20	1.25	20	1.0	20	20	25	
VKU-50-0.25	SCR	SI4	15	32	50		50	30	1.87	20	1.5	20	20	25	
VKU-50-0.5	SCR	SI4	15	32	50		100	30	1.87	20	1.5	20	20	25	
VKU-50-0.75	SCR	SI4	15	32	50		150	30	1.87	20	1.5	20	20	25	
VKU-50-1.0	SCR	SI4	15	32	50		200	30	1.87	20	1.5	20	20	25	
VKU-50-1.5	SCR	SI4	15	32	50		250	30	1.87	20	1.5	20	20	25	
VKU-50-2.0	SCR	SI4	15	32	50		400	30	1.87	20	1.5	20	20	25	
VKU-50-2.5	SCR	SI4	15	32	50		500	30	1.87	20	1.5	20	20	25	
VKU-50-3.0	SCR	SI4	15	32	50		600	30	1.87	20	1.5	20	20	25	
VKU100-0.25	SCR	SI4		22	100		50	40	2.5	20	2.0	20	20	26	
VKU100-0.5	SCR	SI4		22	100		100	40	2.5	20	2.0	20	20	26	
VKU100-0.75	SCR	SI4		22	100		150	40	2.5	20	2.0	20	20	26	
VKU100-1.0	SCR	SI4		22	100		200	40	2.5	20	2.0	20	20	26	
VKU100-1.5	SCR	SI4		22	100		250	40	2.5	20	2.0	20	20	26	
VKU100-2.0	SCR	SI4		22	100		400	40	2.5	20	2.0	20	20	26	
VKU100-2.5	SCR	SI4		22	100		500	40	2.5	20	2.0	20	20	26	
VKU100-3.0	SCR	SI4		22	100		600	40	2.5	20	2.0	20	20	26	
VKUV-100-0.25	SCR	SI4	15			60	100	50	40	2.5	20	2.0	20	27	
VKUV-100-0.5	SCR	SI4	15			60	100	100	40	2.5	20	2.0	20	27	
VKUV-100-0.75	SCR	SI4	15			60	100	150	40	2.5	20	2.0	20	27	
VKUV-100-1.0	SCR	SI4	15			60	100	200	40	2.5	20	2.0	20	27	
VKUV-100-1.5	SCR	SI4	15			60	100	250	40	2.5	20	2.0	20	27	
VKUV-100-2.0	SCR	SI4	15			60	100	400	40	2.5	20	2.0	20	27	
VKUV-100-2.5	SCR	SI4	15			60	100	500	40	2.5	20	2.0	20	27	
VKUV-100-3.0	SCR	SI4	15			60	100	600	40	2.5	20	2.0	20	27	

GROUP XIII, DIODES - REGULATORS

TYPE NUMBER	KIND	TYPE	MAXIMUM			TYPICAL			MAX Z Ω	TC %/°C	K _θ mW/°C	FIG
			I _Z mA	T _{Opr} C	P _Z mW	E _Z V	ΔE _Z %	I _Z mA				
D6	REG	SI	18	150	125	6.5		5.0	10	.03		
D7	REG	SI	18	150	125	7.5		5.0	10	.06		
D8	REG	SI	14	150	125	8.5		5.0	10	.07		
2S-156A	REG	SI	55	120	300	5.6	10	10	46	.05	12	
2S-168A	REG	SI	45	120	300	6.8	10	10	28	.06	12	
D808	REG	SI	33	125	280	7.7	10	5.0	6	.07	3 17	
D809	REG	SI	29	125	280	8.7	10	5.0	10	.08	3 17	
D810	REG	SI	26	125	280	9.7	10	5.0	12	.09	3 17	
D811	REG	SI	23	125	280	11.0	10	5.0	15	.095	3 17	
D813	REG	SI	20	125	280	12.7	10	5.0	18	.095	3 17	
D814-A	REG	SI	40	125	340	7.8	10	5.0	6	.07	5	
D814-B	REG	SI	36	125	340	8.8	10	5.0	10	.08	5	
D814-D	REG	SI	24	125	340	12.8	10	5.0	18	.095	5	
D814-G	REG	SI	29	125	340	11.0	10	5.0	15	.095	5	
D814-V	REG	SI	32	125	340	9.8	10	5.0	12	.09	5	
D815A(P)	REG	SI		125	8W	5.6	10	A1.4	/1	.045	13	
D815B(P)	REG	SI		125	8W	6.8	10	A1.1	/1	.05	13	
D815D(P)	REG	SI		125	8W	12.0	10	650	2	.09	13	
D815G(P)	REG	SI		125	8W	10.0	10	800	2	.08	13	
D815V(P)	REG	SI		125	8W	8.2	10	950	1	.07	13	
D815YE(P)	REG	SI		125	8W	15.0	10	550	3	.10	13	
D815ZH(P)	REG	SI		125	8W	18.0	10	450	3	.11	13	
D816A(P)	REG	SI		125	5W	22	10	230	7	.12	13	
D816B(P)	REG	SI		125	5W	27	10	180	8	.12	13	
D816D(P)	REG	SI		125	5W	4.7	10	110	15	.12	13	
D816G(P)	REG	SI		125	5W	39	10	130	12	.12	13	
D816V(P)	REG	SI		125	5W	33	10	150	10	.12	13	
D817A(P)	REG	SI		125	5W	56	10	90	35	.14	13	
D817B(P)	REG	SI		125	5W	68	10	75	40	.14	13	
D817G(P)	REG	SI		125	5W	100	10	50	50	.14	13	
D817V(P)	REG	SI		125	5W	82	10	60	45	.14	13	
D818A	REG	SI	33	120	300	9.0		11.0	18	.02	70 8	
D818B	REG	SI	33	120	300	9.0		11.0	18	.02	70 8	
D818D	REG	SI	33	120	300	9.0		11.0	18	.002	70 8	
D818G	REG	SI	33	120	300	9.0		11.0	18	.005	70 8	
D818V	REG	SI	33	120	300	9.0		11.0	18	.01	70 8	
D818YE	REG	SI	33	120	300	9.0		11.0	18	.001	70 8	
2S920A(P)	REG	SI	42	130	5W	120			100	.16	13	
2S930A(P)	REG	SI	38	130	5W	130			120	.16	13	
2S950A(P)	REG	SI	33	130	5W	150			170	.16	13	
2S980A(P)	REG	SI	28	130	5W	180			220	.16	13	

GROUP XIV, DIODES - MIXERS AND DETECTORS

TYPE NUMBER	KIND	TYPE	TYPICAL WAVE- LENGTH cm	MAXIMUM								MIN CUR SENS A/W	OPR TEMP		FIG
				RES	LC	NF	VSWR	PULSE PWR		PULSE ENERGY			MIN	MAX	
				Ω	db			CONT mW	PEAK mW	CONT erg	PEAK erg		(-)°C	(+)°C	
DG-S1	MIX	GE	9.8	400	8.5	3.0	3.0	80	250	0.1	3.0		60	70	28
DK-I1	DET	SI	9.8						200			0.5	50	70	30
DK-S1	MIX	SI	9.8	400	8.5	2.7	3.5	80	200	0.1	2.0		60	70	30
DK-V1	VID	SI	9.8	15K				50	200			0.8	50	70	20
DG-S2	MIX	GE	9.8	400	6.5	3.0	3.0	80	250	0.1	3.0		60	70	28
DK-I2	DET	SI	3.2						200			0.2	50	70	30
DK-S2	MIX	SI	9.8	400	6.5	2.0	3.0	50	100	0.06	2.0		60	70	30
DK-V2	VID	SI	9.8	10K				50	100			1.2	50	70	20
D3A	VID	SI	3.2	950			2.5	50	300				60	70	20
D3B	VID	SI	9.8	950			2.5	50	300				60	70	20
DG-S3	MIX	GE	3.2	400	8.5	3.0	3.5	80	250	0.1	3.0		60	70	28
DK-S3	MIX	SI	3.2	400	8.5	2.7	3.0	50	200	0.06	0.6		60	70	30
DK-V3	VID	SI	3.2	15K				50	200			0.4	50	70	20
DG-S4	MIX	GE	3.2	400	6.5	3.0	3.0	50	250	0.1	3.0		60	70	28
DK-S4	MIX	SI	3.2	400	6.5	2.7	2.5	30	100	0.06	0.3		60	70	30
DK-V4	VID	SI	3.2	10K				50	100			0.8	50	70	20
DK-V5	VID	SI	9.8	10K				50	200			0.8	50	70	30
DK-V6	VID	SI	9.8	25K				50	200			0.8	50	70	30
DK-S7	MIX	SI	3.2	900	7.0	2.0	2.0	50		0.15			60	80	28
DK-V7	VID	SI	3.2	10K				50	200			0.4	50	70	30
D401	MIX	GE	8.5	1K	13.0			15					5	50	29
D403A	MIX	GE	9.8	700	9.0	3.0	3.0		150	0.15			60	100	20
D403B	MIX	GE	9.8	600	8.5	3.0	3.5		150	0.15			60	100	20
D403V	MIX	GE	9.8	600	9.0	13.0	2.8		150	0.15			60	100	20
D405	MIX	SI		400	7.0		2.0	80		0.6			60	100	31
D405A	MIX	SI		350	6.0		1.7	80		1.0			60	100	31
D405AP	MIX	SI		350	6.0		1.7	80		1.0			60	100	31
D405B	MIX	SI		330	8.0		1.4	80		1.0			60	100	31
D405BP	MIX	SI		330	8.0		1.4	80		1.0			60	100	31
D602A	VID	GE	3.2	600			3.2		50			1.5	60	85	28
D602B	VID	GE	3.2	900			3.2		50			1.5	60	85	28
D602V	VID	GE	3.2	900			3.2		50			4.0	60	85	28
D603	VID	SI	9.8	900			2.0		200			4.0	60	100	30

GROUP XV, DIODES-PHOTOCONDUCTIVE DEVICES

TYPE NUMBER	KIND	MAXIMUM		DARK		SENSITIVITY		T.C.	TIME CONT.	TEMP		WEIGHT	K AREA
		VOLTS	CUR. μ A	POWER mW	RESISTANCE $m\Omega$	CURRENT μ A	mA/μ			MAX μ	CUT OFF μ		
FS-AG	PBS	15			0.04		500	2.1	2.7	1.5	60	60	24
FS-AO	PBS	15			0.04		500	2.1	2.7	1.5	60	60	24
FS-AV	PBS	100			0.01		500	2.1	2.7	1.5	60	60	96
FS-DO	CDSE	200			20.0		20M	0.75	1.2	2.0	60	40	25
FS-KG	CDS				3.3		6000	0.64	0.9	0.2	60	80	25
FS-KO	CDS	300			3.3		1200	0.52	0.9	0.12	60	80	25
FS-KV	CDS	200			1.6		6000	0.64	0.9	0.2	60	80	50
FD-1	GE	15	15			30	20M	1.4	1.7		60	40	20
FDK-1	SI	20				3	3000	0.9	1.3		10	50	80
FS-A1	PBS	15			0.04		500	2.1	2.7	1.5	60	60	24
FS-D1	CDSE	200			20.0		20M	0.75	1.2	2.0	60	40	25
FS-K1	CDS	400			3.3		6000	0.64	0.9	0.2	60	80	25
FT-1	GE	3				300	500M	1.4	1.7		60	50	0.9
FTG-1	GE	15	50			1000	20M	1.4	1.7		40	40	1
FD-2	GE	30	15			25	20M	1.4	1.7		10	45	14
FS-2A	PBS	17			0.3			0.7	3.5		60	40	9
FS-B2	BIS	50			0.2								121
FS-K2	CDS	300			3.3		1200	0.52	0.9	0.12	60	80	25
FD-3	GE	15				10	20M	1.4	1.7		60	60	9
FS-3A	PBS	10			2.0			0.7	3.5		60	40	52
FS-K3	CDS	300			3.3		1200	0.52	0.9	0.12	60	80	25
FS-A4	PBS	15			0.04		500	2.1	2.7	1.5	60	60	24
FS-K4	CDS	300			2.0		6000	0.64	0.9	0.2	60	80	24
FS-K5	CDS	300			10.0		3000	0.64	0.9	0.2	60	80	7
FS-A6	PBS	30			0.05		500	2.1	2.7	1.5	60	60	115
FS-D6	BIS	200			20.0		20M	0.75	1.2	2.0	60	40	115
FS-K6	CDS	300			3.3		3000	0.64	0.9	0.2	60	80	115
FS-K7	CDS	100			0.05		3500	0.64	0.9	0.2	60	80	200
FS-K8	CDS	300			10.0		1600	0.64	0.9	0.2	60	80	15

GROUP XVI, PHOTO AND PHOTOMULTIPLIER TUBES

TYPE NUMBER	KIND	TYPE	BULB DIMEN			CATHODE			MAXIMUM				OUTPUT SENS		DYNODES			AMPLIFICATION
			SHAPE	DIAM	LGTH	AREA	SURF	SENS $\frac{\mu A}{lm}$	E_b V	I_k μA	DARK I		MIN Amp/L	OPR E_{cb}	DESIGN	MAT'L	NO	
				mm	mm						cm	Amp						
F-1	PHO	VC	T	39	104		S2		30		5	11						
FEU-1	PHO		G	40	124		S2	400	250		1	7	1	220				
FEU-1B	PHM		B	80	285	44	S13	90	2000	300	1	7	3		L	AMK	11 6	
FEU-1B1V	PHM		T	80	225	44	S13	90	2500	1M	1	7	30		C	AMK	10 7	
FEU-1B2V	PHM		T	80	225	44	S13	30	2500		1	7	300		C	AMK	12 7	
FEU-1S	PHM		T	48	205	12	S13	90	1950	300	1	7	3		L	AMK	11 6	
FEU-1V	PHM		T	48	166	12	S13	90	2500	1M	1	7	30		C	AMK	10 7	
TSG-1	PHO	GS	G	56	131		S1	75	240		1	7	1					
TSV-1	PHM	VC	G	56	131		S1	20	240		1	7	1					
F-2	PHO	VC	T	20	67		S2	5	2		1	8	1					
FEU-2	PHM		G	31	71		S2	400	250		1	7	1	220				
FEU-2B	PHM			150	295	155	S13	90	2000	300	1	7	3		L	AMK	11 6	
FEU-2B1V	PHM		B	80	225	44	S13	90	2500		1	7			C		12 7	
FEU-2M	PHM		T	34	130	5	S13	90	1600	300	1	7	3		L	AMK	13 5	
FEU-2V	PHM		T	50	170	12	S10	90	2500	1M	1	7	300		C	AMK	12 7	
STSV-2A																		
F-3	PHM	VC	G	92	163			40	50									
FEU-3B	PHM		B	200	295	227	S13	90	2000	300	1	7	3		L	AMK	11 6	
FEU-3M	PHM		T	19	75	/2	S13	90	1500	100	5	8	1		L	AMK	8 5	
FEU-R3	PHM		T	47	109	2	S13	90	1400		1	10			C		10	
STSV-3	PHO	VC	G	27	62		S2	80	240		1	8	1					
TSG-3	PHO	GS	G	27	62		S1	100	240		1	7	1					
TSV-3	PHO	VC	G	27	62		S1	20	240		1	7	1					
F-4	PHO	VC	T	39	104		S2	70	80		1	14						
STSV-4	PHO	VC	G	39	129		S2	80	240		1	7	1					
TSG-4	PHO	GS	G	39	129		S1	100	240		1	7	1					
TSV-4	PHO	VC	G	39	129		S1	20	240		1	7	1					
F-5	PHO		T	42	104		S1		100		8	11						
FEU-R5	PHM		T	47	109	2	S13	90	1400		1	7	1		C		10	
F-6	PHO		G	33	76		S7	40	100		1	11						
STSV-6	PHO	VC	T	27	104		S1		30		5	11						
TSV-6	PHO	VC	T	27	104		S1		30		5	11						
F-8	PHO		G	27	62		S2	80	150		1	8						
FEU-11	PHM		T	52	235	16	S5	80	2500		8	7	5		V	CAM	12 7	
FEU-12	PHM		T	52	235	16	S10	80	2500		8	7	5		V	CAM	12 7	

GROUP XVI, PHOTO AND PHOTOMULTIPLIER TUBES

TYPE NUMBER	KIND	TYPE	BULB DIMEN			CATHODE			MAXIMUM				OUTPUT SENS		DYNODES			AMPLIFICATION
			SHAPE	DIAM	LGTH	AREA	SURF	SENS $\frac{\mu A}{lm}$	E_b V	I_k μA	DARK I		MIN Amp/L	OPR E_{vb}	DESIGN	MAT'L	NO	
				mm	mm						cm	Amp						
FEU-13	PHM	T	52	162	17	S13	50	2200		4	7	6	2200	L	CAM	12		
FEU-14	PHM	T	52	162	17	S10	40	2200		4	7	6	2200	L	CAM	12		
FEU-15	SCC	T	31	115	3	S10	25	2200		4	7	6	1700	L	CAM	12		
FEU-16	SCC	T	31	115	12	S13	25	2200		4	7	6	1700	L	CAM	12		
FEU-17	PHM	T	48	181	/1	S13	20	1400	100	3	7	10	900	L		13		
FEU-17A	PHM	T	48	181	/1	S13	20	1400	100	3	7	10	900	L		13		
FEU-18	PHM	T	48	181	/1	S3	20	1400	100	3	7	10	900	L		13		
FEU-18A	PHM	T	48	181	/1	S3	20	1400		3	7	10	900	L		13		
FEU-19M	PHM	T	48	195	9	S10	35	2600	200	1	5	1000	2600	L		13	7	
FEU-20	PHM	T	34	95	5	S13	20	1400	100	8	9	1	900	L		8		
FEU-22	PHM	T	48	181	/1	S1	25	2000	300	2	8	1	1400	L		13		
FEU-23	PHM		305	450	700	S10	20	2400	10			10		L	AMK	11	5	
FEU-24	SCC	T	80	230	44	S13	25	2000	100	3	7	10	1600	L		13	6	
FEU-25	PHM	T	34	109	5	S13	20	1700	100	5	8	1	1250	L		9	6	
FEU-26L	PHM	T	22	70	/1	S13	20	900		2	8	10	2000			7		
FEU-27	PHM	T	30	108	5	S17	30	2000		5	9					1		
FEU-29	SCC	T	48	195	9	S13	30	2300	200	3	8	10	1400	L	CAM	13	7	
FEU-31	PHM	T	22	79	10	S13	20	1400	750	5	7	10	1300	L		8		
FEU-32	PHM	T	34	123	5	S10	25	1800	200	1	8	1		L	AMK	11	6	
FEU-33	SCC	T	48	195	9	S13	30	2900		1	6	100	2100	L		13	7	
FEU-34	PHM				9	S13	30	2700		1	5	1000		L		13		
FEU-35	SCC	T	31	113	5	S13	30	1750		4	9	10	1400	L		8		
FEU-36	PHM		48	195	12	S13	30	2900	1M	2	5	2900		L		13		
FEU-37	PHM		48	178	9	S13	30	1800	200	3	6	1800		L		11		
FEU-38	PHM				9	S20	90	2000		1	7	100		L		13		
FEU-39	PHM				9	S13	25	1700		6	9	10		L		11		
FEU-40	NSP	T	20	91		S13	30	1900		5	7	1				8		
FEU-42	NSP	T	48	205		S13	30	2200		1	7	1	1800			11		
FEU-43	NSP	T	80	290		S13	30	2200		1	7	1	1800			11		
FEU-44	NSP	B	150	310		S13	30	2200		1	7	1	1800			11		
FEU-45	NSP	B	200	340		S13	30	2200		1	7	1	1800			11		
FEU-46	NSP	T	48	130		S13	30	1800		1	10	1	1800			10		
FEU-47	NSP	T	48	169		S13	30	2500		1	7	1	2300			10		
FEU-48	NSP	T	80	230		S13	30	2500		1	7	1	2300			10		
FEU-49	PHM	B	170	220	95	S20	80	3500		1	8	10	1800			12		
STSV51	PHO VC	G	30	63		S2	80	240		1	8							
FEU-52	PHM	B	80	125	45	S20	80	3000		5	8	8	1700	V	CAM	12	7	
FEU-53	PHM	T	51	117	16	S9	40	2500	10M	4	7	40	1700	V	CAM	14	7	

GROUP XVIII, THERMOCOUPLE

TYPE NUMBER	KIND	DIMENSIONS		TYPICAL		RESPONSE s	f _{max} MHz
		DIAM mm	LENGTH mm	I _H mA	THERMO ELEC. mV		
TVB-1	THM	20	30	1	73	40	200
TV-2	THM	13	23	100	30	35	5
TVB-2	THM	20	30	3	5	40	200
TVB-3	THM	20	30	5	10	40	200
TV-4	THM	13	23	50	30	35	5
TVB-4	THM	20	30	10	12	40	200
TV-5	THM	13	23	75	30	35	5
TVB-5	THM	20	30	30	12	40	200
TVB-6	THM	20	30	30	12	40	200
TVB-7	THM	20	30	100	12	40	200
TVB-8	THM	20	30	300	12	40	200
TVB-9	THM	20	30	500	12	40	200
TV-14	THM	13	23	250	30	15	5
TV-15	THM	15	20	500	30	35	5
TV-16	THM	15	20	1000	30	35	5

GROUP XIX, THERMISTORS

TYPE NUMBER	KIND	USE	DIMEN			RESISTANCE			TEMP.		POWER		SENS Ω mW
			DIAM	LTH	SHAPE	MIN	MAX	T.C.	MIN	MAX	MIN	MAX	
			mm	mm		Ω	Ω	%	(-) ^o C	(+) ^o C	mW	mW	
KMT-1	TMS	MEA	13	7/4	CYL	20K	1M	5.1	20	180		8H	
MMT-1	TMS	MEA	13	7/4	CYL	1	200	2.9	70	120		4H	
KMT-4	TMS	MEA	24	7	CYL	20K	1M	5.1	20	180		8H	
MMT-4	TMS	MEA	24	7	CYL	1	200	2.9	70	120			
MMT-6	TMS					10	1000	2.9	70	120		50	
KMT-8	TMS					100	10K	4.6	40	60			
MMT-8	TMS	COM	22	23	DSC	1	1000	2.9	40	60		10	
T8D	TMS	POW	8	3	CYL	150					10	15	20
T8E	TMS	POW	8	3	CYL	150					7	10	30
T8M	TMS	POW	8	3	CYL	200					9	11	66
T8R	TMS	POW	8	3	CYL	125					7	12	10
T8S1	TMS	POW	8	3	CYL	120					9.5	24	10
T8S1M	TMS	POW	8	3	CYL	120					9.5	24	10
T8S2	TMS	POW	8	3	CYL	150					8	19	12
T8S2M	TMS	POW	8	3	CYL	150					8	19	12
T8S3	TMS	POW	8	3	CYL	150					7	23	10
T8S3M	TMS	POW	8	3	CYL	150					7	23	10
MMT-9	TMS	COM	7/3	19	DSC	10	5000	2.9	60	120		10	
T9	TMS	POW	8	3	CYL	125					7	19	10
KMT10	TMS	CON	30	6	CYL	100K	3M	5.1	0	120		2H	
KMT-11	TMS	CON	7/4	7/1	CYL	100K	3M	5.1	0	120		2H	
KMT-12	TMS					100	10K	4.6	40	120			
MMT-12	TMS					5	5K	2.9	40	120		3	

GROUP XX, STROBOTRONS

TYPE NUMBER	DIMENSIONS		VOLTAGE			POWER		INTER RES		FLASH CONDITIONS				LIGHT OUTPUT			LIFE	
	SHAPE	DIAM mm	LTH mm	MIN DROP V	OPER V	FIRING V	AVG W	PEAK kW	RES Ω	DISCHG CAP μF	TIME μs	FLASH FREQ pps	ENERGY j	FLASH cd/s	AVG cd	PEAK cd	NO. OF FLSH	HRS
ISK10	U	5	30	180	300	1000	10	3	0.8	1.0	15	200	0.1	7U	15	500	50	
ISP10	T	1	62	700	1000	3000	10	6	30	0.2	18	100	0.1	50U	5	3K	500	
IST10	U	5	30	180	300	1000	10	50	0.8	220	200	1	10	8	40K	50		
IFK15-1	T	29	60		300		3	90	1.5	800	400	0.1	36	36	9K	2K		
IS-SH15	T	1	2	250	1000	1200	1	20		20	15		10	5	300K	1	5K	
IFK20	T	4	10	100	130	700	2	100	1.6	25H	200	0.1	20	20	100K	10K		
ISK25	U	5	20	250	300	1000	20	130	0.4	450	150	1	20	40	30K	30		
IFK50	T	4	20	140	200	1K	5	125	0.3	25H	400	0.1	50	70	180K	10K		
ISP70	T	0.5	70	900	1200	3000	70	10	1H	0.2	18	400	0.2	100U	40	6K	100	
IS-SH100-1	T	0.7	2	2200	3000	3500	4000			11	15		50	50	3M	1	2	
IS-SH100-3	T	2	5	2500	3500	6K	150	1000		0.5	2	50	3	2	100	600K	5	
IFK120	U	5	30	180	300	1K	12	120	0.8	25H	1K	0.1	120	250	250K	10K		
IFP200	T	5	200	450	500	2K	27	140	2.0	16H	16H	0.13	200	400	250K	10K		
IFB300	R	8	85	240	300	1500	40	36	2.5	65H	8K	0.13	300	500	60K	10K		
IFK500	P	30	45	400	500	3500	30	65	4.0	4K	8K	0.05	500	1000	130K	10K		
IFP500	T	5	350	450	500	3K	65	70	3.5	4K	7K	0.13	500	1000	140K	10K		
IS-SH500	T	1.2	8	5K	9K	15K	500	1000		0.12	6	100	5	5	1M	1		
IFP1500	T	5	600	900	1K	4K	100	160	6.0	3K	9K	0.06	15H	4000	450K	10K		
IFK2000	U	9	70	250	320	2K	300	200	4.5	8K	2K	0.7	400	1200	600K	40K		
IFP4000	T	6	800	1300	1400	5K	270	250	8.0	4K	16K	0.06	4K	12K	750K	10K		
IFP15000	T	9	600	1600	2400	5K	1250	3300	1.8	5K	45H	0.08	15K	50K	11M	10K		
IFK20000	G	85		2K	6K	20K	55H	10M	3.5	550	11H	0.55	10K	34K	30M	7K		
IFK80000	G	1H		3K	6K	20K	18K	13M	2.5	39H	5K	0.25	70K	240K	36M	5K		

GROUP XXI, COUNTERS

TYPE NUMBER	KIND	RADIATION	QUENCHING	CATHODE	DIMENSIONS		PLATEAU		MAXIMUM			TEMP		CAP	MIN R _i	FIG
					DIAM	LENGTH	MIN	MAX	RATE	PLATEAU		MIN	MAX			
					mm	mm	v	v	10 ³ / _{min}	WIDTH V	SCOPE % V	(-)°C	(+)°C			
AS-1	COU	BAG			132	18	830	940		80	0.2	0	35			
SBS-1	COU	BAG			125		800	1200		150	0.03	50	50			
SI-1BG	COU	BAG	SQ	NI	60	15	375	410				40	50	5	/1	11
SI-1G	COU	BET	SQ	FE	94	16	280	320	60	80	1.25	40	50	10	5	8
AS-2	COU	BAG		AL	160	25	750	860		100	0.15	0	35			
SI-2B	COU	BET	SQ	SN	90	70	1350	1750	8	150	0.5	30	50	10	7	13
SI-2BG	COU	BAG	SQ	NI	60	15	375	410				40	50	5	3	12
STS-2	COU	BET	SQ	FE	180	24	285	335	40	80	1.25	40	50	10	5	9
SBT-3	COU	AAB			93	50	1800	2100		150		30	50			
SI-3B	COU	BET	SQ	CU	90	40	1650		10	150	0.3	20	40	10	7	6
SNM-3	COU				135	18	700	1000		100	0.05	0	30			
STS-3	COU	BET	SQ	FE	265	23	285	335	30	80	1.25	40	50	10	5	8
GS-4	COU	GAM	SQ	GR	180	23	1100	1300		200	1.0			25	8	3
MS-4	COU	GAM	SQ	CU	180	23	720	780	25	200	1.0	40	50	25	8	4
STR-4	COU	BET	SQ	CU	180	40	1200	1350	25	200	0.5	5	35	25	8	7
MSBS-4	COU	BET		GR	362	23							50			
SI-4G	COU	GAM	SQ	W	367	33	720	800	25	200	1.0	40	150	25	8	1
VS-4	COU	GAM	SQ	W	180	23	720	800	25	200	0.75	40	50	25	8	1
SBS-5	COU	BET		GR	255	23							50			
SGS-5	COU	GAM			60	8	340	440		80	0.20	50	50			
SNM-5	COU				300	35	1200	1800		100	0.05	20	30			
STS-5	COU	BET	SQ	FE	113	12	280	330	100	80	1.25	40	50	10	5	9
GS-6	COU	GAM	SQ	GR	266	23	1100	1300		200	1.0			25	8	3
MS-6	COU	GAM	SQ	CU	266	23	720	780	25	200	1.0	40	50	25	8	4
SGS-6	COU	GAM			90	8	340	440		80	0.15	40	80			
STS-6	COU	BET	SQ	FE	200	22	285	335	60	80	1.25	40	50	10	5	10
VS-6	COU	GAM	SQ	W	266	23	720	800	25	200	0.75	40	50	25	8	1
GS-7	COU	GAM	SQ	GR	145	16	1100	1300		150	1.0			25	30	3
MS-7	COU	GAM	SQ	CU	145	16	720	780	25	100	1.5	25	50	25	30	4
SAT-7	COU	ALP			70	25	330	400		60	0.12	40	50			
SBM-7	COU	BET			335	26							50			
SBT-7	COU	BET			72	20	340	380		80	0.12	40	50			
SNM-7	COU				650	35	1800	2500		100	0.05	0	30			
GS-8	COU	GAM	SQ	GR	185	16	1100	1300		150	1.0			25	30	3
MS-8	COU	GAM	SQ	CU	185	16	720	780	25	100	1.5	25	50	25	30	4

GROUP XXI, COUNTERS

TYPE NUMBER	KIND	RADIATION	QUENCHING	CATHODE	DIMENSIONS		PLATEAU		MAXIMUM			TEMP		CAP	MIN R _i	FIG
					DIAM	LENGTH	MIN	MAX	RATE	PLATEAU		MIN	MAX			
										mm	mm					
SAT-8	COU	AAB				4	500	1000		300	0.03	40	50			
SBM-8	COU	BET			335	26							50			
SBT-8	COU	AAB			75	20	1100	1700		150		30	30			
SNM-8	COU				16H	35	1300	1700		150	0.05	0	30			
STS-8	COU	BET	SQ	FE	220	23	285	335	40	80	1.25	40	50	10	5	8
VS-8	COU	GAM	SQ	W	185	16	720	800	25	150	1.0	40	50	25	30	1
GS-9	COU	GAM	SQ	GR	367	33	1100	1300		250	1.0			25	8	3
MS-9	COU	GAM	SQ	CU	367	33	720	780	25	250	1.0	40	50	25	8	4
SNM-9	COU				133	20	1000	1600		400	0.05	0	30			
VS-9	COU	GAM	SQ	W	367	33	720	800	25	250	0.75	40	50	25	8	1
GS-10	COU	GAM	SQ	GR	225	16	1100	1300		150	1.0			25	30	3
SBT-10	COU	AAB		LD		51	340	460		80		60	60			
GS-11	COU	GAM	SQ	GR	185	33	1100	1300		200	1.0			25	8	3
MS-11	COU	GAM	SQ	CU	185	33	720	780	25	200	1.0	40	50	25	8	4
VS-11	COU	GAM	SQ	W	185	33	720	800	25	200	0.75	40	50	25	8	1
GS-12	COU	GAM	SQ	GR	145	16	1100	1300		150	1.0			25	30	3
MS-12	COU	GAM	SQ	CU	145	16	720	780	25	100	1.5	25	50	25	30	4
MS-13	COU	GAM	SQ	CU	100	23	720	780	25	200	1.5	40	50	25	8	5
VS-13	COU	GAM	SQ	W	100	23	720	800	25	150	1.0	40	50	25	8	2
MS-14	COU	GAM	SQ	CU	160	23	720	780	25	200	1.0	40	50	25	8	5
VS-14	COU	GAM	SQ	W	160	23	720	800	25	200	0.75	40	50	25	8	2
MS-16	COU	GAM	SQ	CU	250	23	720	780	25	200	1.0	40	50	25	8	5
VS-16	COU	GAM	SQ	W	250	23	720	800	25	200	0.75	40	50	25	8	2
MST-17	COU	BET	SQ	CU	100	40	1600		10	150	0.5	30	50	10	7	6
T20BFL	COU	AAB			7	20	1200	1300		300	0.01	20	40			
T25BFL	COU	AAB			7	25	1300	1400		300	0.01	20	40			
GS-30	COU	GAM	SQ	GR	662	33	1100	1300		150	1.0			25	8	3
T30BFL	COU	AAB			7	30	1400	1500		300	0.01	20	40			
T40BFL	COU	AAB			7	40	1500	1600		300	0.01	20	40			
T50BFL	COU	AAB			7	50	1500	1600		300	0.01	20	40			
GS-60	COU	GAM	SQ	GR	667	63	1100	1300		150	1.0			25	8	3
T60BFL	COU	AAB			7	60	1900	2000		300	0.01	20	40			
T80BFL	COU	AAB			80	90	2000	2100		300	0.01	20	40			

GROUP XXII, DISCHARGE DIODES														
TYPE NUMBER	DIMEN		CAS	CATH		FIRING		PULSE			MIN INTER RES MΩ	MAX CAP pF	AMB. TEMP	
	LTH	DIAM		TYPE	KIND	MIN	MAX	I-amp J-joule	TIME s	OPERATING FREQUENCY pps			MIN	MAX
	mm	mm				v	v							
RB-1	52	19		C	BA	150	190				400			
R-2	17	16.5		C		1300	2K			600	20		50	80
RB-2	25	19		C	BA		220	50	15U	50	100	/1	60	70
R-3	70	21.5		C	BAO		600	140	12U	300	100	1	60	70
RB-3	41	22		C	BA	220	235	30	1HU	7	100		60	70
R-4				C	BAO		75							
R-5	41	22		C	BAO	160	250				100			
RB-5	60	16		C	BA	340	460	10J		1	200		60	70
RB-5A	60	16		C	BA	370	510	/1J		8			60	50
R-6	110	55				800				200 M	100			
R-7	45	18	HK	C	BAO	270	330			2	20	10	60	100
R-8	50	20	HK	C	BAO	450	550			2	20	10	60	100
R-9	55	20	HK	C	BAO	900	1100			2	20	10	60	100
R-10	55	20	HK	C	BAO	1375	1725			2	20	40	60	100
R-11	132	35		C	NI	2250	2750	2HU						
R-12	30	12	AR	C	K	145	175	20	1U		1000			
R-54						7200	9800							
RB-90	62	17.5	NA	C	BA	80	100	30M	2	0.005	100	100	60	70
SK-127	37	20	NA		MG		72	1	20	1				
SK-220	37	20	HE				140	/1	20	1				
RB-280	210	95	AR	C	BA	250	310	30	10	0.002	40	20	60	70
R-350	62	20	AR	C	BA	310	390	3	2	0.002	5K	10	50	50
RB-350	210	95	AR	C	BA	310	390	30	10	0.002	40	20	60	70
RB-430	210	95	AR	C	BA	390	470	30	10	0.002	40	20	60	70
R-450	62	20	AR	C	BA	440	480	3	2	0.002	5K	10	50	50

GROUP XXIII, DECATRONS													
TYPE NUMBER	KIND	VOLTAGES						TYP I _b mA	PULSE		DIMEN		
		MAXIMUM			TYPICAL				TYP	MAX	LTH	DIA	
		E _b V	FIRING V	BIAS V	DRP V	OPER V	K ₁ K ₂ V ²		TIME μs	RATE kHz	mm	mm	
OG-1	DEC	450	300	150	15	150	50	1.3	40	8	77	34	
OG-2	DEC	450	300	150	15	150	50	1.3	60	3	77	34	
OG-3	DEC	460	420	120	15	190	40	0.7	18	20	83	34	
OG-5	DEC	400	350	120	20	175	60	1.3	35	10	74	34	

GROUP XXIV, LIGHT AMPLIFIERS										
TYPE NUMBER	KIND	K	SCRN COLOR	MAX DIMEN			AMP μ	TYP E _b V	RESOL	
				K	SCREEN				10 ^{-X}	LINE PER mm
					mm	mm				
LIM-3	LAM	CSB	VB	15	65	20	2	18	8	70
LIM-4	LAM	CSB	VB	15	135	40	4	18	9	70

GROUP XXV, BASES

BASE NO.	SECTION 1										SECTION 2					SEC. 4		DEFLECTION I				DEFLECTION 2									
	H	H	K	K	g ₁	g ₂	g ₃	g ₄	g ₅	A	Sh	H	H	H	K	g ₁	g ₂	g ₃	A	A ₃	K	A	A ₅	D ₁	D ₂	D ₃	D ₄	D ₁	D ₂	D ₃	D ₄
A4	2	4	3	1						CP																					
A7	1	7	6	5						2											3 CP										
A8	2	8	7	5						3											CP										
A9	2	7	6	4						CP																					
A12	1	12	2	3						8											4										
A14	1	14	2	3						9																					
A20	1	20	3	5	16					11											5 CP										
A25	1	25	2	24	6					23											CP										
B7	3	4	2	5	7					6											11										
B8	1	8	3	6						CP																					
B9	3	9	1	8						6																					
B12	1	12	11	2	10					6											CP										
B14	1	14	2	3	9					9											5 CP										
C8	1	8	7	2	6					4											CP										
C14	1	14	13	12	CP					CP																					
D8	2	8	6	4						CP																					
D14	1	14	2	3	4					5											CP										
DS1	4	5	5							CP																					
DS2	2	7	2							CP																					
DS3	1	5								CP																					
DS4	2	7								4																					
DS5	1	2	1							CP																					
DS6	2	5																													
DS7	1	3																													
DW1	2	8								4																					
DW2	1	2	3							4																					
DW3	1	8	3							4																					
DW4	2	8	8							4																					
DW5	2	6	3							1																					
DW6	3	4	5							7																					
DW7	2	7	8							3																					
DW8	1	3	2							4																					
DW9	3	4	1							7																					
F8	1	8	7	6	3					5																					
G8	1	8		6						CP																					

GROUP XXV, BASES

BASE NO.	SECTION I										SECTION 2								SEC. 4				DEFLECTION I				DEFLECTION 2					
	H	H	K	g ₁	g ₂	g ₃	g ₃	g ₄	g ₅	A	Sh	H	H	K	g ₁	g ₂	g ₃	A	A ₃	A	K	A	A ₅	D ₁	D ₂	D ₃	D ₄	D ₁	D ₂	D ₃	D ₄	
PS8	2	7		4	5				CP																							
PS9	4	5	3	7	2	3			1																							
PT1	3	5		2	1	6			4			5	7		8			9														
PT2	7	8	6	CP	3	6			2						5			4														
PT3	2	7	8	1	4	8			6						5			3														
PT4	4	5	7	8	9	7			6	7				3	1		2															
PT5	4	5	2	3	7	2			6	2				8	1		9															
PT6	4	5	8	9	7	8			6																							
TT5	1	4		3					CP																							
T25	4	5	1	2					7																							
T35	1	4	5	3					2					2	3		5															
TD1	4	8	6	7					1																							
TD3	2	7	8	CP					3																							
TE1	1	6	4	8	5				2																							
TE2	1	7		2	CP				4																							
TE3	4	5		8	2				3																							
TE4	1	3		2	4				CP																							
TE5	1	3		4	2				CP																							
TE6	2	7		5	4				CP																							
TE7	1	7	7	3	6				CP																							
TS1	1	7		5					2																							
TS2	2	3		4					1																							
TS3	1	3	2	6					4																							
TS4	4	5	3	1					9																							
TS5	2	7	8	CP					CP																							
TS6	2	6	3	5					4																							
TS7	4	5	9	2					1																							
TS8	2	7	1	5					CP	3																						
TS9	2	7		CP					CP																							
TT1	4	5	7	8					9																							
4AC	2	7	7						CP																							
4AJ	4	BB	2	7	8	CP			5	3																						
4BQ	2	7	8						CP																							
4D	1	4		3					2																							

GROUP XXV, BASES

BASE NO.	SECTION I										SECTION 2						SEC. 4		DEFLECTION I				DEFLECTION 2							
	H	H	K	g ₁	g ₂	g ₃	g ₄	g ₅	A	Sh	H	H	K	g ₁	g ₂	g ₃	A	A ₃	K	A	A ₅	D ₁	D ₂	D ₃	D ₄	D ₁	D ₂	D ₃	D ₄	
4F	1	3		4																										
4G	1	4	3					2																						
4T2	1	2		4				CP																						
5AA	2	7	8					5																						
5AW	1	5	4	3	2	4		CP																						
5BT	2	7	3	5	8	3		CP																						
5CL	3	5	4	2	5			1																						
5F	1	5	4	CP	3	4		2																						
5M	2	7	8	CP				4																						
5S	2	7		5				3																						
5Y	2	7		CP	4	7		3																						
6AR	1	7		6	3	5		2																						
6AU	1	7		6	4	1		5																						
6BT	3	4	5					2	6																					
6BY	2	7	3	CP				CP																						
6CC	3	4	2	1	6	2		5																						
6F	1	6	5	CP	3	4		2																						
6Q	2	7	8	5	4			3	1																					
6X	2	7		5	4	7		3																						
7AB	2	7		4				3																						
7AT	1	7		4	3	6	3	1	2																					
7AV	1	7		3	4	5		1																						
7BA	1	7		3	4	5		2																						
7BD	3	4	2	1	6	7		5																						
7BF	3	4	7	5				2																						
7BK	3	4	7	1	6	2		5																						
7BP	1	7	4	2	3	4		CP																						
7BQ	3	4	2	1				7																						
7BS	3	4	2	6				1																						
7CH	3	4	2	1	6	7	6	2	5																					
7CM	3	4	2	1	6	7		5																						
7DF	3	4	1	2	5	6		7																						
7DN			2	1				1																						
7EM	3	4	2	1	5			6																						
7R	2	7	8	CP	4	5		3																						

GROUP XXV, BASES

BASE NO.	SECTION I										SECTION 2					DEFLECTION I					DEFLECTION 2									
	H	H	K	g ₁	g ₂	g ₃	g ₄	g ₅	A	Sh	H	H	K	g ₁	g ₂	g ₃	A	A ₃	K	A	A ₅	D ₁	D ₂	D ₃	D ₄	D ₁	D ₂	D ₃	D ₄	
7S	2	7	8	5	4	8			3																					
7T	2	7	8	CP	4	5	4	8	3																					
7Z	2	7	7	5	6	4	CP	4	3																					
8A	2	7	8	5	6	4	CP	4	3																					
8AN	2	7	4						3	1																				
8B	2	7	8	4					3																					
8BD	7	8	3	1					2																					
8BE	7	8	2	1					3																					
8BK	2	7	3	4	6	3			8																					
8CJ	1	9	2	3					4	5																				
8E	2	7	8	CP	6	8			3																					
8ES	2	7							CP																					
8HC	2	7							8																					
8N	2	7	5	4	6	3			CP																					
8Q	7	8	3	2					6																					
8R	2	7	6	5	4	8	4	1	3																					
8S	7	8	6	3					2																					
8T1	3	4	2	1	5				7																					
8T2	2	7	8	5	6				3																					
8T3	2	7	8	5					3																					
8Y	2	7	5	4	6	1			8																					
9AE	4	5	7	2	3	7			6																					
9AJ	4	5	3	2					1	9																				
9BD	4	5	CP						2																					
9CA	4	5	3	2	1	7	1	3	6																					
9CB	4	5	CP						9																					
9CV	4	5	3	2	9	3			7																					
9DD	4	5	1	2					3																					
9EQ	4	5	1	2	9	8			7																					
10T	1	10	5	2	6				8																					
11L	1	11	2	10					7																					
14G	1	14	2	3					9																					
14J	1	14	2	3					9																					

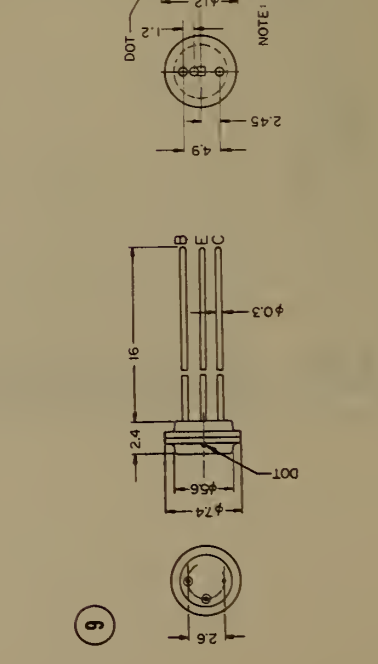
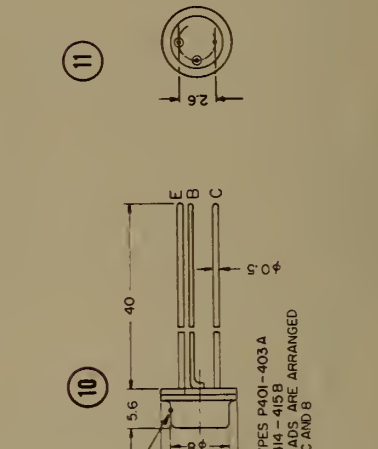
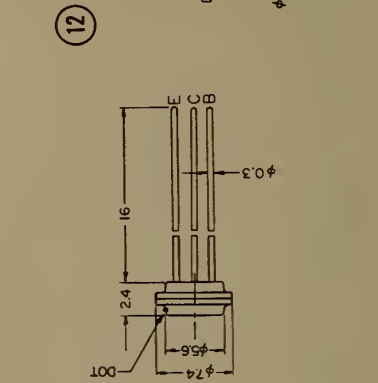
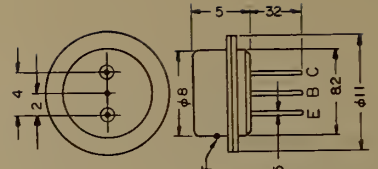
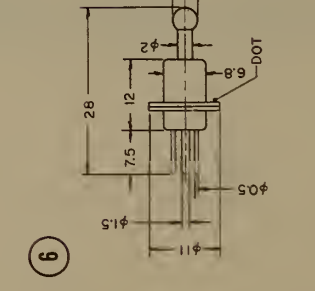
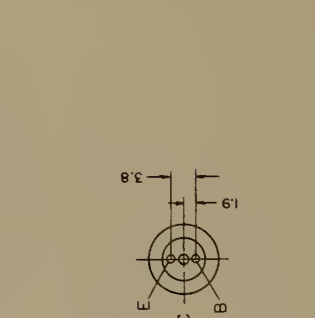
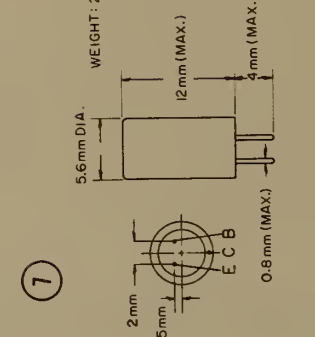
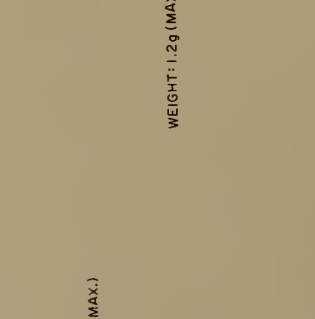
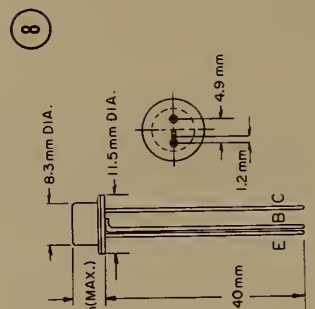
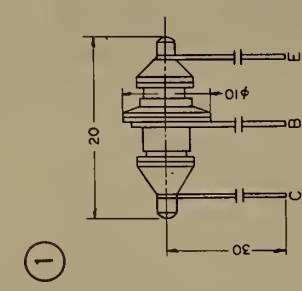
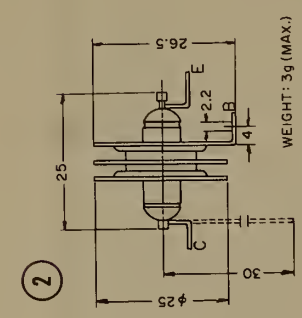
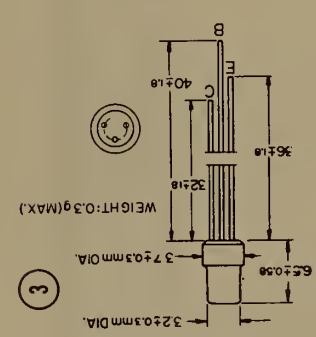
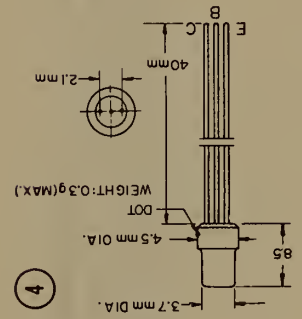
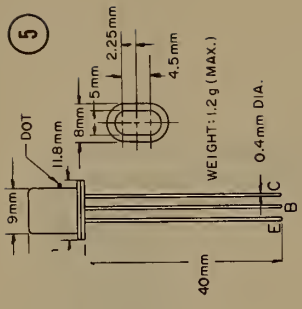

NOTE: TYPES PA01-403 A
PA14-415 B
LEADS ARE ARRANGED
E, C AND B

TRANSISTOR OUTLINE DRAWINGS GROUP X

13

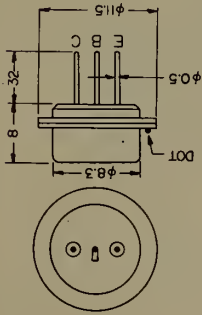

14

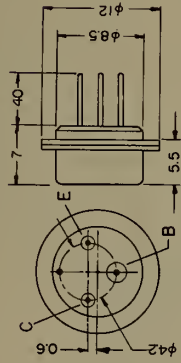

15

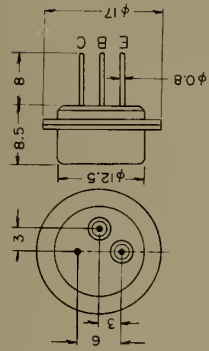

16

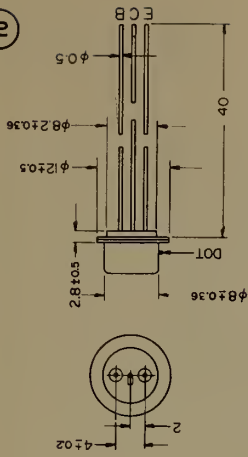

17

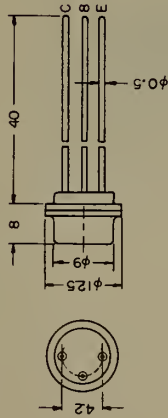

18

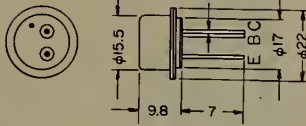

19

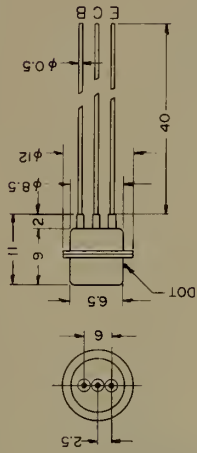

20

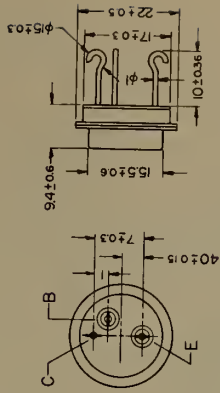

21

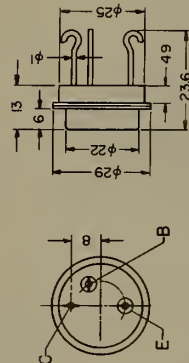

22

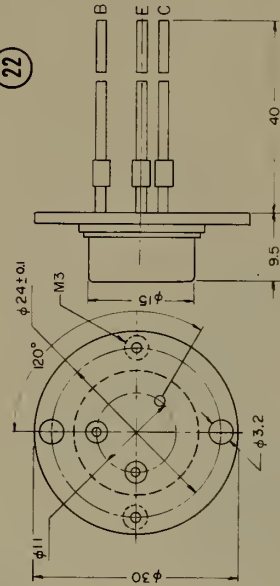

23

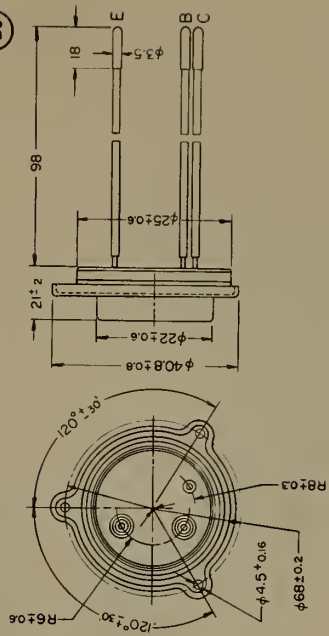

TRANSISTOR OUTLINE DRAWINGS
(CON'T)

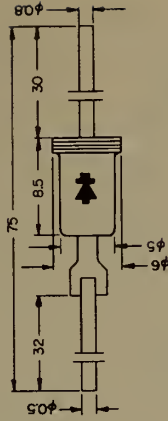
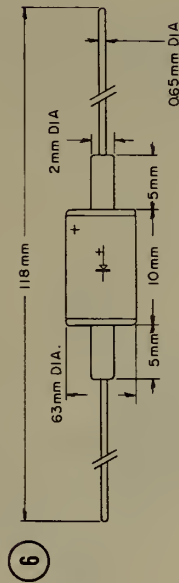
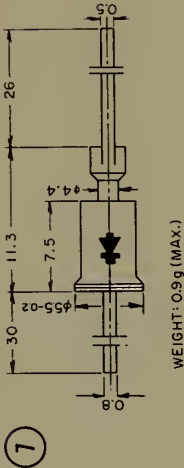
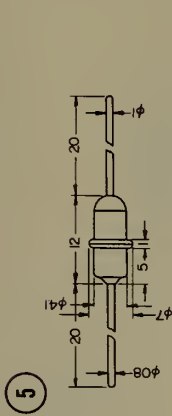
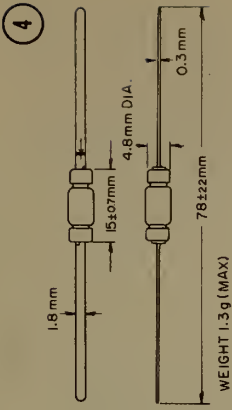
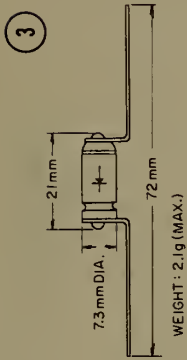
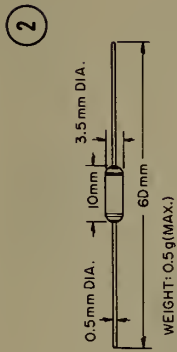
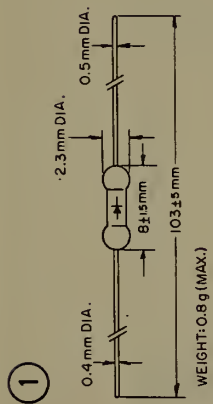

WEIGHT UNKNOWN

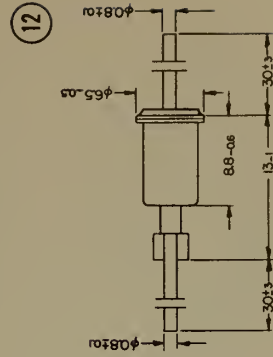
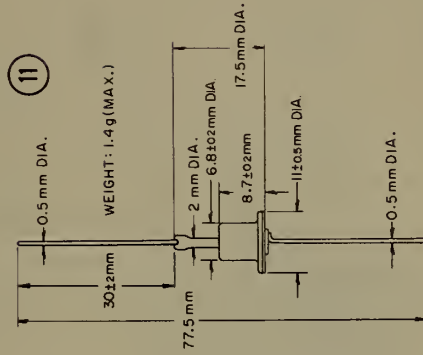
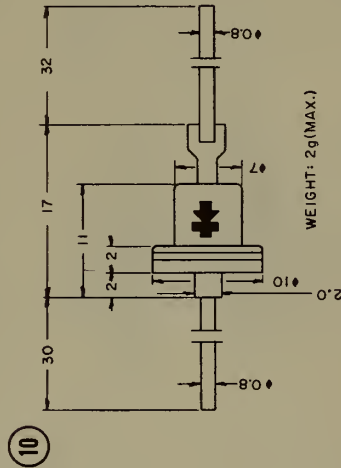
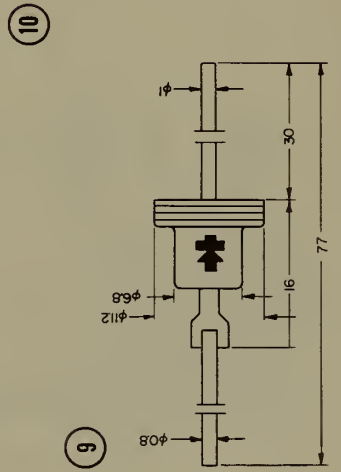

DIODE OUTLINE DRAWINGS

GROUPS XI, XII, XIII & XIV

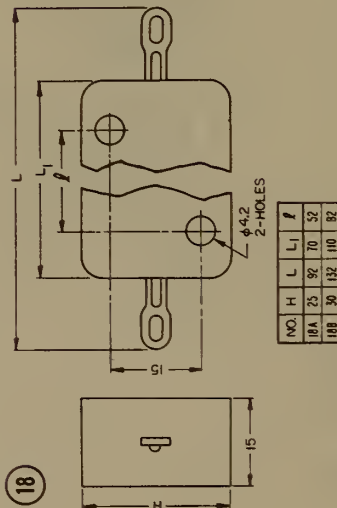
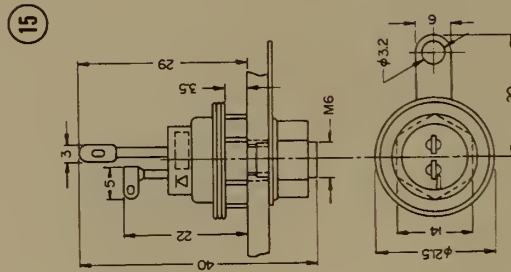
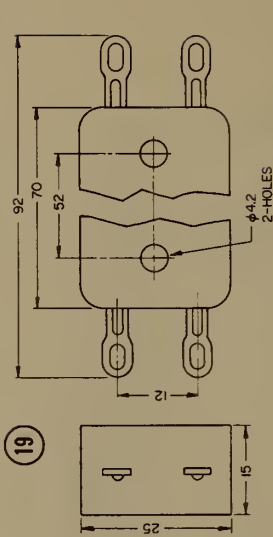
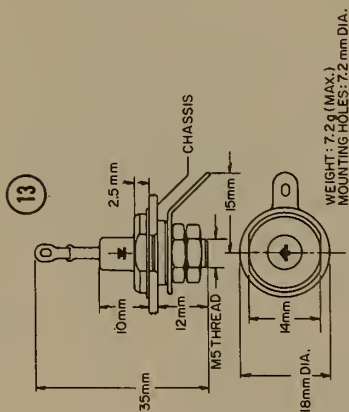
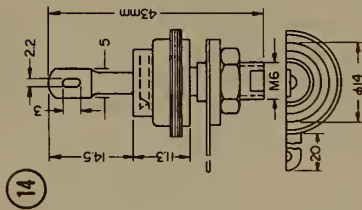
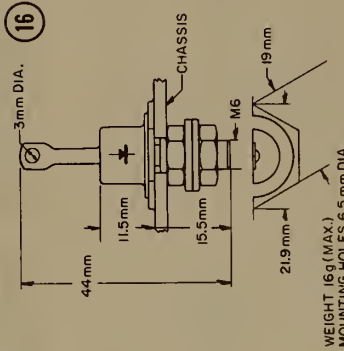
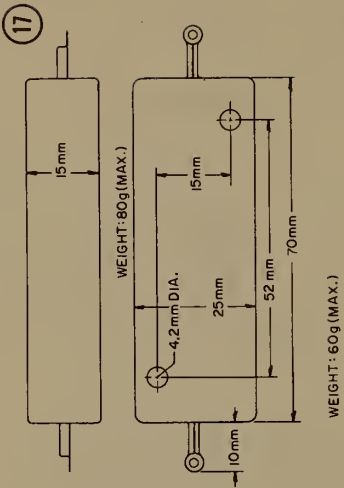

NO.	H	L	L ₁	φ
18A	25	92	70	52
18B	30	132	110	82

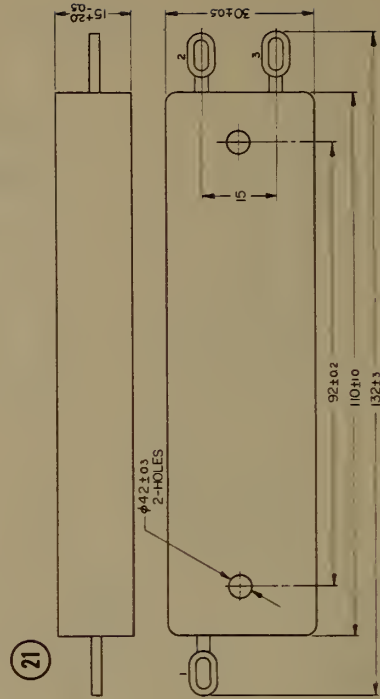
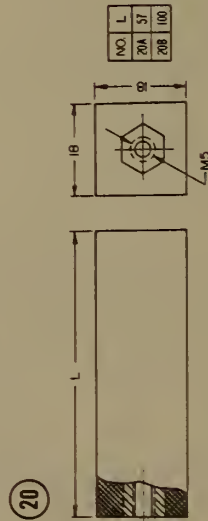

DIODE OUTLINE DRAWINGS (CON'T)

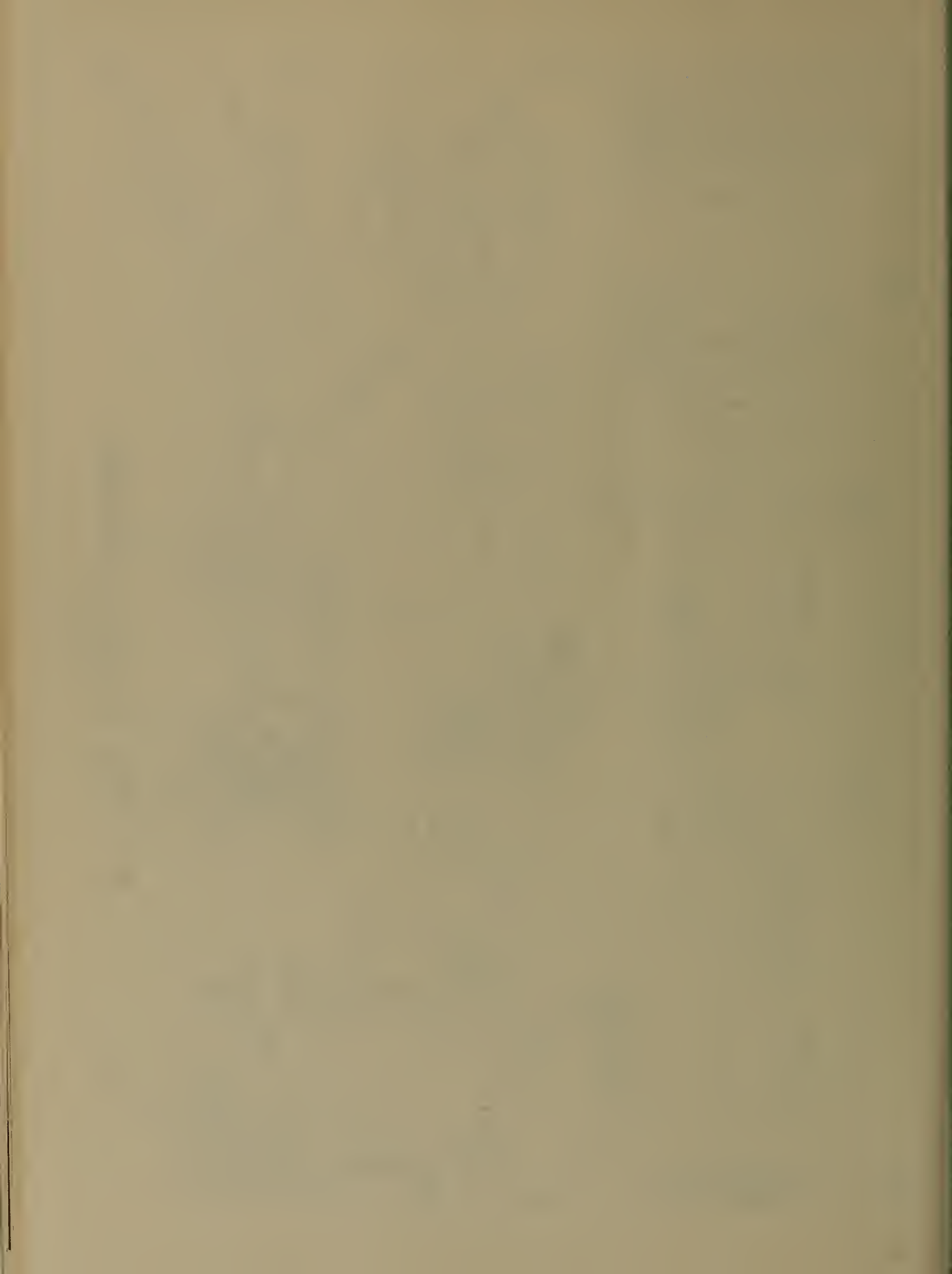



U.S. DEPARTMENT OF COMMERCE
WASHINGTON, D.C. 20210

OPTIONAL FORM NO. 10
MAY 1962 EDITION
GSA FPMR (41 CFR) 101-11.6

OFFICIAL BUSINESS
