

Div. 505

NBSIR 80-2033 R

FILE 8571  
DO NOT REMOVE

MAY 14 1980

# Measurements and Standards for Nuclear Materials Safeguards

---

Edited by:

B.S. Carpenter and F. E. Jones

National Measurement Laboratory  
National Bureau of Standards  
U.S. Department of Commerce  
Washington, DC 20234

May 1980

Annual Report, Fiscal Year 1979  
(October 1, 1978 - September 30, 1979)

Prepared for

**Division of Siting, Health and Safeguards Standards**  
**Safeguards Standards Branch**  
**Office of Standards Development**  
**U.S. Nuclear Regulatory Commission**  
**Under Contract No. AT(49-25)-9009**



# **MEASUREMENTS AND STANDARDS FOR NUCLEAR MATERIALS SAFEGUARDS**

---

Edited by:  
B.S. Carpenter and F. E. Jones

National Measurement Laboratory  
National Bureau of Standards  
U.S. Department of Commerce  
Washington, DC 20234

May 1980

Annual Report, Fiscal Year 1979  
(October 1, 1978 - September 30, 1979)

Prepared for  
Division of Siting, Health and Safeguards Standards  
Safeguards Standards Branch  
Office of Standards Development  
U.S. Nuclear Regulatory Commission  
Under Contract No. AT(49-25)-9009



---

**U.S. DEPARTMENT OF COMMERCE, Philip M. Klutznick, *Secretary***

**Luther H. Hodges, Jr., *Deputy Secretary***

**Jordan J. Baruch, *Assistant Secretary for Productivity, Technology, and Innovation***

**NATIONAL BUREAU OF STANDARDS, Ernest Ambler, *Director***

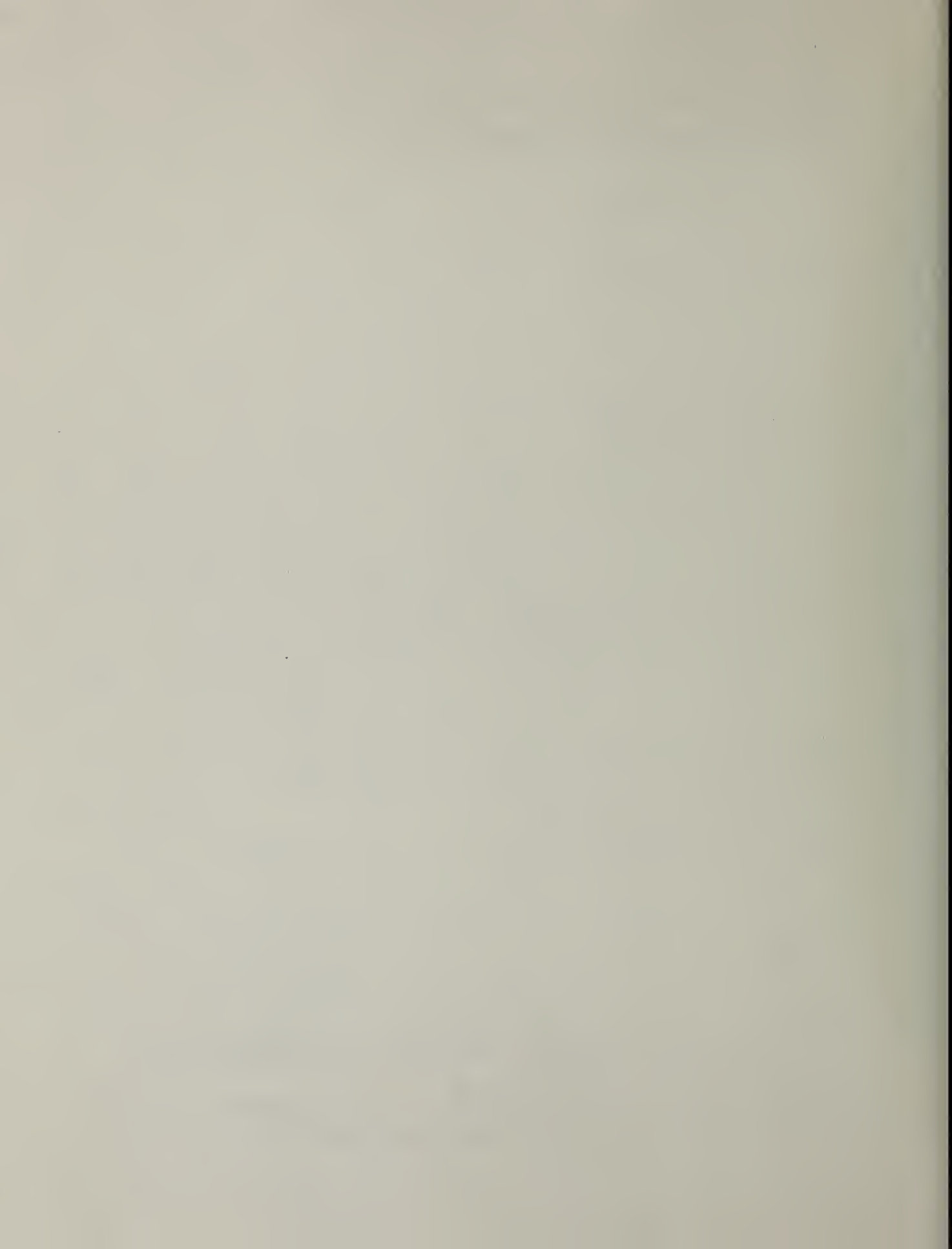

## PREFACE

This report was prepared for the U.S. Nuclear Regulatory Commission,  
Office of Standards Development, under Interagency Agreement No. AT(49-25)-9009.

	<u>Page</u>
ABSTRACT . . . . .	iii
INTRODUCTION . . . . .	v
PROGRESS OF TASKS	
TASK I: STANDARDIZATION OF DESTRUCTIVE ANALYTICAL CHEMISTRY METHODOLOGY FOR NUCLEAR MATERIALS . . . . .	1
Sub-Task A: SRM Research and Reference Methodology . . . . .	1
Sub-Task B: Support of Measurement Assurance Programs . . . . .	2
Sub-Task C: Chemical and Isotopic Characterization Support for NDA . . . . .	3
TASK II: STANDARDIZATION OF NON-DESTRUCTIVE (NDA) METHODOLOGY FOR NUCLEAR MATERIALS . . . . .	4
Sub-Task A: NDA Reference Materials Research . . . . .	4
Sub-Task B: Reference Method Development . . . . .	9
Sub-Task C: NDA Calibration Methodology . . . . .	19
TASK III: STANDARDIZATION OF BULK MEASUREMENT TECHNOLOGY IN NUCLEAR FUEL CYCLE PLANTS . . . . .	21
Sub-Task A: Process Tank Volume Measurements Standardization . . . . .	21
Sub-Task B: UF <sub>6</sub> Cylinder Measurement Assurance Program . . . . .	26
Sub-Task C: Flow Measurement Standardization . . . . .	27
TASK IV: APPLIED MATHEMATICS FOR NUCLEAR SAFEGUARDS . . . . .	29
Sub-Task A: Development and Standardization of Statistical Procedures for the Safeguards Community . . . . .	29
Sub-Task B: Facility Error Analysis Study . . . . .	30
Sub-Task C: Statistical Support for Other NBS Tasks . . . . .	31
TASK V: USERS GUIDE, SAFEGUARDS ACCOUNTABILITY INSTRUMENTATION AND TECHNIQUES . . . . .	32

## ABSTRACT

This report is a review of the progress made during Fiscal Year 1979 (October 1, 1978 through September 30, 1979) of a long-term NBS program sponsored by the Nuclear Regulatory Commission (NRC) to upgrade national measurements and standards capability for nuclear materials safeguards. The Nuclear Regulatory Commission sponsored program at NBS is a synergistic part of the overall NBS program in this area which is sponsored jointly by the Nuclear Regulatory Commission, the Department of Energy, and the Department of State (ISPO).

A summary of the progress for each of the five NRC-supported Tasks in the project is given. The first Task involves the standardization of analytical chemical methodology - work in this Task includes: the development of a  $^{233}\text{U}$  "spike" SRM for isotope dilution mass spectrometry; determination of the uranium content and isotopic composition of samples from the Safeguards Analytical Laboratory Evaluation (SALE) Program; and research to improve uranium mass spectrometry measurements.

The second Task is concerned with the standardization of Non-Destructive Assay (NDA) methodology - work in this Task includes development of a series of low-enriched  $\text{U}_3\text{O}_8$  NDA Gamma Spectroscopy NBS-SRM's; work with the INMM Standards Committee 9.3 to produce ANSI N15 Draft Document, "Standard Methods for Preparing Calibration Material for Non-Destructive Assay by Passive Gamma Ray Counting"; the calibration of plutonium heat source reference materials for calorimetry; the establishment of a test facility for resonance neutron radiography (a possible NDA reference method) and the completion of experiments confirming the scientific validity of the method; effort toward using resonance neutron tomography (another possible NDA reference method) with reactor-produced neutrons for high-accuracy measurements and for the establishment of reference standards; investigations of chemical effects on nuclear reactions which might influence the interpretation of measurements, improve the accuracy of detectors or lead to more new and accurate measurement on the capture cross section of  $^{238}\text{UF}_6$  gas; and construction of a Segmented Gamma Scan Unit to be used in the analysis of strategic nuclear material in scrap and waste cans.

The third Task involves the standardization of bulk measurement technology - the work in this Task includes: the standardization of tank volume measurements and the transfer of the technology to the field; the completion and laboratory testing of a prototype dynamic volume calibrator intended to make tank volume calibration more convenient, less time-consuming and less subject to operator error; the characterization of pressure transducers; the establishment of the feasibility of in-tank determination of the density of nuclear process solutions in the field with a precision competitive with the precision claimed for laboratory determinations; the implementation of a Measurement Assurance Program (MAP) to improve in-facility weighing of large  $\text{UF}_6$  cylinders; and the completion of the fabrication of a mobile flow prover for calibration of nuclear facility flow measurement systems and field testing of the prover at a nuclear facility.

The fourth Task applies mathematics and statistics to nuclear safeguards - the work in this Task involves the statistical interactions between NBS and safeguards-related groups such as ASTM Committee C26, the SALE Steering Committee, INMM and NRC; a facility error analysis study contributing to the correct assessment of material balances and their uncertainties in facilities inspected and regulated by NRC; statistical support for other NBS nuclear safeguards Tasks.

The fifth Task involves the development of a Users Guide to provide specific recommendations on how facilities should be designed to accommodate the necessary measurements to meet the SNM accountability goals of the safeguards program - the work in this Task includes the preparation of a planning document to define the task of writing the Users Guide, visits to facilities and architect/engineering firms to discuss views on how the Users Guide should be prepared to be most useful, and the writing of a preliminary draft.



## INTRODUCTION

An adequate measurement and accounting system is necessary for the detection of and protection against unauthorized removal of special nuclear materials by persons having authorized access to facilities. The sensitivity of this type of detection depends directly on the uncertainties of measurement. The NBS program will assure the availability of the certified reference materials, reference measurement methods, reference data and quality assurance methodology for the adequate standardization of measurements for nuclear safeguards. Domestic and international dissemination is required.

The goal of the NBS program is:

To assure that measurement standards exist for the timely measurement of special nuclear material throughout the fuel cycles so that measurements can be performed at reasonable cost with accuracy sufficient for the safeguarding of nuclear material. These measurements of enriched uranium, plutonium, and related materials need to be made domestically by both Nuclear Regulatory Commission (NRC) and Department of Energy (DOE) inspectors, government facilities, and the industry. In addition, these measurements need to be made by other countries and the International Atomic Energy Agency (IAEA).

The overall NBS program is currently funded by NRC, DOE, and the Department of State (ISPO). The program may be viewed as consisting of three related parts: (1) development of capability including: calibration standards, reference measurement methods, sampling schemes, statistical treatment of data, data generation; (2) dissemination mechanisms to transfer the standards and reference methods and data to the users; and (3) mechanisms to directly assist inspectors and the nuclear industry to ensure that their measurements are of sufficient accuracy.

In order to carry out the tasks assigned to NBS in a timely manner, NBS must continually assess the advancing needs for national and international measurement standards. NBS has received substantial guidance and input from NRC as to standards needs. Continued input from all appropriate NRC organizations will be extremely helpful and are solicited.

The NBS Measurements for Nuclear Safeguards Program is broadly organized into five Tasks: chemical and isotopic measurements; non-destructive assay; bulk measurements; statistics, sampling and error analysis; and the development of a users guide for accountability instrumentation and techniques.

Consideration for needed reference data is included in each of the first four Tasks. The research is being carried out in six line organizations at NBS: Center for Radiation Research, Center for Applied Mathematics, Center for Materials Science, Center for Thermodynamics and Molecular Science, Center for Analytical Chemistry, and the Center for Mechanical Engineering and Process Technology. Researchers with backgrounds in analytical chemistry, mass and volume measurement, nuclear and radiation physics, thermodynamics, mechanics, etc. are part of the program team. NBS is also supplying a substantial amount of equipment, both old and new, that is needed to carry out the program.

NRC is supporting an important portion of the total NBS program on measurements for nuclear safeguards in all of the above mentioned Task areas.

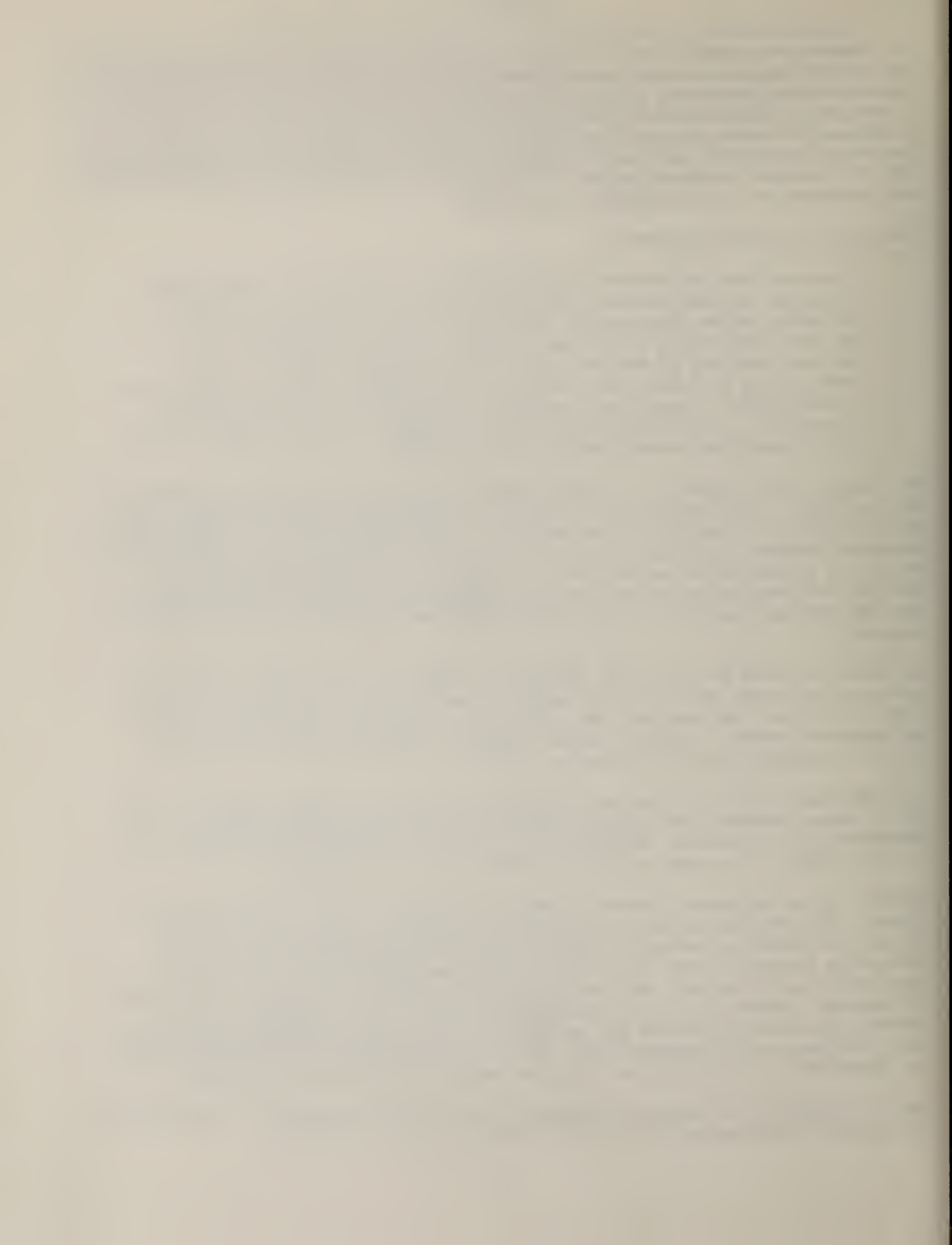

TASK I: STANDARDIZATION OF DESTRUCTIVE ANALYTICAL  
CHEMISTRY METHODOLOGY FOR NUCLEAR MATERIALS

The goal of the Destructive Analytical Chemistry Task is to provide standardization for wet chemical and mass spectrometric methodology used for the assay of nuclear materials. This Task is divided into three components (Sub-Tasks): A - Standard Reference Material (SRM) Research and Reference Methodology; B - Support of Measurement Assurance Programs (MAPs); and C - Chemical and Isotopic Characterization Support for Non-Destructive Assay (NDA).

Sub-Task A: SRM Research and Reference Methodology

The goal of this Sub-Task is certification of a  $^{233}\text{U}$  "spike" SRM for both uranium elemental concentration and isotopic composition. This material is intended as a spike for mass spectrometric determination of the isotopic and elemental composition of uranium in the full range of materials found in the nuclear fuel cycle. With this material, a single analysis can be used to obtain both the elemental concentration and the isotopic composition of uranium.

The master solution of  $^{233}\text{U}$  was prepared from a chemically pure and isotopically pure (99.9 atom %  $^{233}\text{U}$ ) uranium oxide ( $\text{U}_3\text{O}_8$ ). The solid material was dissolved in high purity  $\text{HNO}_3$ , converted to the chloride form, and purified by an anion exchange separation to remove  $^{229}\text{Th}$  and other daughter products. Before ampouling, the uranium solution was converted to the nitrate form and thoroughly mixed by stirring with a teflon covered magnetic stirring bar. To determine the weight of solution being delivered to the ampoules and to make sure there was not a significant evaporation loss in sealing the ampoules,

ampoules were periodically weighed before filling, after filling, and after sealing.

Following a sampling plan supplied by the NBS Center for Applied Mathematics for the analysis of samples, eight ampoules of spike were reserved for the assay measurement. These samples represented two consecutive ampoules at the beginning, at the end, and approximately 1/3 and 2/3 of the way through the ampouling sequence. The uranium concentrations of two aliquots from each ampoule were determined by isotope dilution mass spectrometry using both NBS SRM 960 (uranium metal) and NBS SRM 993 ( $^{235}\text{U}$  spike) to calibrate. The close agreement between concentrations of the  $^{233}\text{U}$ , independent of spiking material, indicate a lack of significant systematic error in the calibration process. The final estimate of systematic error will be made after the completion of statistical analysis.

This SRM will soon be available as a high purity solution containing 5 mg of  $^{233}\text{U}$  in  $\sim 10$  mL of 1 M  $\text{HNO}_3$ . When available, it will have the effect of reducing the analytical effort for concentration determinations by a factor of 2.

#### Sub-Task B: Support of Measurement Assurance Programs

High precision and high accuracy measurements are made at NBS to support MAPs by providing the "true value" for uranium elemental concentration and isotopic composition of reference samples distributed in selected national and international evaluation programs.

During FY 78, NBS determined the uranium content of an NBS/SALE depleted uranium using both coulometry and the NBL titrimetric method. During FY 79, enriched uranium SALE samples were analyzed by the Davies-Gray titrimetric method using SRM 960 as a control.

The isotopic composition of a series of depleted uranium SALE samples was determined by thermal ionization mass spectrometry. An NBS single-stage

mass spectrometer possessing Faraday-cup detection was used with the standard triple-filament uranium procedure. NBS SRM U-005 with a  $^{235}\text{U}/^{238}\text{U}$  ratio of 0.004919 was used to calibrate the measurement process. The fractionation correction of 0.99865 for the  $^{235}\text{U}/^{238}\text{U}$  ratio was applied to the experimental ratios.

The isotopic composition of an enriched uranium SALE sample was similarly determined by thermal ionization mass spectrometry. The fractionation correction of 0.99931 for the  $^{235}\text{U}/^{238}\text{U}$  ratio was determined in a system calibration in which NBS SRMs U-100 to U-900 were analyzed in an identical fashion to the SALE sample.

#### Sub-Task C: Chemical and Isotopic Characterization Support for NDA

Research (supported by DOE) to improve the sample mounting procedure for uranium thermal ionization mass spectrometry was completed. It was demonstrated that sample filament temperature is a critical parameter during this phase of the analysis and must be precisely reproduced for precise ratio measurements  $\leq 5$  parts in  $10^4$ . After the completion of this work, an investigation of spurious background masses in the 230-240 mass range was restarted with NRC support. The effort is directed primarily toward elimination or reduction of background to a level of insignificance rather than toward making positive identifications.

As a first step, the level of background was evaluated at ionizing filament temperatures between 2160 °C and 2040 °C. At 2160 °C, the operating temperature for most uranium mass spectrometry measurements of this nature, background interferences of approximately  $2-3 \times 10^{-15}$  A are occasionally detected. It now appears that a temperature at or below 2100 °C will reduce the interference below the detection limits of the conventional Faraday-cup detector. Modified uranium analysis procedures using both 2100 °C and 2120 °C as the optimum ionizing filament temperatures are now being tested. A final selection of a

"safe" temperature will require more evaluation during the routine analysis of uranium samples.

The investigators for this Task are J.D. Fassett, E.L. Garner, H.M. Kingston, L.A. Machlan and J.R. Moody.

TASK II: STANDARDIZATION OF NON-DESTRUCTIVE (NDA)  
METHODOLOGY FOR NUCLEAR MATERIALS

The objective of this Task is to provide a common and accurate basis for the non-destructive assay of nuclear fuels and disseminate to industry, Government, other countries and the International Atomic Energy Agency (IAEA). This Task is divided into three components (Sub-Tasks): A - NDA Standard Reference Materials Development. The effort in this Sub-Task is directed toward the development of primary (facilities - independent) NBS certified reference materials to be used for the calibration of NDA instruments. These NBS-certified SRMs will be used by others for the evaluation and development of NDA methods and for the production of NDA secondary or working reference materials. B - Reference Method Development. The effort is directed toward the development of reference methods to be used for the characterization of NDA reference materials. C - NDA Calibration Methodology. This Sub-Task provides for the standardization of calibration procedures for NDA. This includes dissemination through participation in voluntary standards writing activities. In addition, potential factors influencing NDA calibration or data handling are defined.

Sub-Task A: NDA Reference Materials Research

A major portion of the effort in this Sub-Task has been on the development of a series of low-enriched  $U_3O_8$  NDA Gamma Spectroscopy NBS-SRMs. This is a cooperative project involving NBL, LASL, NBS and Euratom Labs. NBS provided some input to Central Bureau for Nuclear Measurements (CBNM) on their design

of a suitable aluminum container for the reference materials and helped to finalize the specifications for the  $U_3O_8$  materials. Specifications were required for a number of parameters including: chemical assay, enrichment, chemical and isotopic homogeneity, and radioactive impurities.

Four sets of prototype reference materials were prepared by the Euratom Laboratory at Geel (CBNM) and were analyzed by three other laboratories of the Euratom Joint Research Center (Geel, Ispra and Karlsruhe) enroute to NBS for analysis. These four sets of samples, three of which had constant density and varying enrichment (0.3%, 0.7% and 3%) and one set with constant enrichment (3%) but varying density, were analyzed in detail at NBS by NBS personnel, as well as T.D. Rielly and J. Parker of LASL. The results of the analyses (see Table 1) were used as input at a meeting with members from the Euratom Laboratories to formulate plans for the final standards to be certified. Development of the final standards is expected to be completed by September 1980 with certification and dissemination to follow in a few months. The SRMs will consist of  $^{235}U$  enrichments of 0.27, 0.7, 1.2, 1.9, 2.9 and 4.0%.

TABLE 1  
 $^{235}U$  Enrichment Data on  $U_3O_8$  NDA Test Samples

<u>Samples</u>	<u>n</u>	<u>% Enriched (Declared)</u>	<u>Measured Value</u>
Depleted	5	0.298	0.2979 <u>+</u> 0.0002
Natural	6	0.720	0.720 <u>+</u> 0.0006
Enriched	4	2.95	2.950 <u>+</u> 0.0024
Enriched with Varying Density	4	2.95	2.950 <u>+</u> 0.0027

During the course of the year, a computer program for testing the homogeneity of the samples was developed and evaluated by T. Mitlehner and R. Fleming. Lead collimators of three different configurations were designed

and built. The resolution and efficiency, for the 186 keV peak of  $^{235}\text{U}$ , of the High Purity Germanium Detector System were evaluated.

The investigator for this portion of the Sub-Task is B. Stephen Carpenter.

Another portion of this Sub-Task is work with the INMM Standards Committee 9.3 to produce a draft ANSI N15 Draft Document, "Standard Methods for Preparing Calibration Material for Non Destructive Assay by Passive Gamma Ray Counting".

The investigator for this portion of the Sub-Task is B. Stephen Carpenter.

A modest portion of this Sub-Task concerns the calibration of plutonium heat source reference materials for calorimetry. The overall goal of the calorimetric activity (also partially supported by DOE) in this Sub-Task is to provide measurement assurance and traceability to National Standards for calorimetric measurements made in the industrial assay of plutonium-bearing solids.[1] This activity aims at the establishment of an automated calorimetric measuring system which will be used to check periodically at frequent intervals the certified power of encapsulated plutonium heat sources submitted by the major industrial producer(s) of these sources (at present, the Mound Laboratory is the only one). Sufficient agreement between the NBS measurements and those of the producer(s) could be used as a rationale for certification of these producers' sources as "NBS Special Reference Materials".

It is planned to incorporate into the NBS calorimetric facility automatable heat-flow calorimeters of the "Mound design". This will involve an apparatus development period which is underway and should be completed in FY 81. In the meantime, NBS has available for heat measurements a heat-flow calorimeter on loan from the Mound Laboratory (power range to 5 W) as well as the NBS Bunsen ice calorimeter [2] which will be used as an independent reference method.



Since there is an urgent need for establishing immediately some degree of traceability to National Standards for industrial calorimetric NDA measurements, we have carried out a series of heat measurements on an encapsulated plutonium source provided by the Mound Laboratory. These measurements, described below, will be used to provide interim traceability for heat measurements prior to the existence of a formal Measurement Assurance Program (MAP).

The heat-flow calorimeter on loan from the Mound Laboratory is a twin-type calorimeter [1] ("twin" implies the existence of a "measuring chamber" and a "compensating chamber") which requires for its operation intimate thermal contact with a massive heat sink controlled to 0.001 K or better. Such a heat sink can be provided through a large water bath of which our laboratory now has two: one obtained for initial testing as surplus and modified by us and one designed and constructed this year in our laboratory. We are presently working to improve the control on the designed bath which has not been satisfactory to date.

We have been continuously testing the Mound calorimeter (for stability, calibration, and behavior in power measurements) and while we believe the overall design to be sound, there are some areas in which modifications are desirable. We are using both the original Mound engineering drawings and our own experience gained with a Mound calorimeter to draw up specifications and a design for our own calorimeter.

In order to carry out the measurements in the Bunsen ice calorimeter referred to above, some time was spent on modifying the equilibrating bath used to pre-condition measuring specimens for this calorimeter. Using this modified bath, the nickel resistance thermometer used to measure specimen temperatures was recalibrated. Since our apparatus development program also includes probing the minimum and maximum powers at which the ice calorimeter is usable, work was started on modification of the calorimeter calibrator

circuitry and improved temperature controls for an oil bath were completed. This bath is used to thermostat precision resistors used in the measurement of calibration power.

In order to provide interim traceability for heat measurements prior to creation of a formal MAP, power measurements were made on a Mound-encapsulated plutonium heat source labeled "1.0 WK" (power level of 1.0 watt). These were made in both the ice calorimeter and the Mound heat-flow calorimeter, using three different observers. Details of the experimental methods used in the ice calorimeter measurements are given in [2], and details of measurements by the DVM/replacement method in the heat-flow calorimeter are given in [1]. The power data are given in Table 2.

TABLE 2  
Power Measurements on Encapsulated Plutonium Source "1.0 WK"

Date (1979)	Operator	NBS-Measured Power W	Mound-Predicted Power W	NBS-Mound %	
1 {	20 Mar.	A	0.970046	0.970419	-0.0380
	21 Mar.	A	0.969833	0.970398	-0.0580
	22 Mar.	B	0.969038	0.970377	-0.1380 <sup>3</sup>
	27 Mar.	B	0.969514	0.970273	-0.0780
	28 Mar.	B	0.969745	0.970253	-0.0524
	28 Mar.	B	0.970317	0.970253	+0.0070
	29 Mar.	B	0.970403	0.970232	+0.0180
	30 Mar.	A	0.969760	0.970212	-0.0466
	30 Mar.	A	0.969440	0.970212	-0.0796
	04 Apr.	A	0.970018	0.970108	-0.0090
	04 Apr.	A	0.969820	0.970108	-0.0296
	04 Apr.	A	0.970218	0.970108	+0.0113
	2 {	26 June	C	0.9682	0.968388
06 July		C	0.96793	0.96818	-0.0258
09 July		C	0.96812	0.96812	+0.0000
02 Aug.		C	0.967775	0.967622	+0.0158

<sup>1</sup>Ice calorimeter data

<sup>2</sup>Heat-flow calorimeter data

<sup>3</sup>Outlier; discarded

The power data from the ice calorimeter show no apparent operator bias. The average deviation of these 11 data is -0.03 percent from the values predicted by the source supplier (Mound). This is well within our estimated overall inaccuracy (+0.05 percent), but greater than the overall inaccuracy claimed by Mound for their data (+0.01 percent). The power measurements made with our Mound heat-flow calorimeter deviate on the average by -0.007 percent from the values predicted by Mound. We do not yet have sufficient experience with this apparatus to enable us to estimate an overall inaccuracy in our heat-flow calorimetric data.

The agreement of the present NBS measurements with the data predicted by the Mound Laboratory, taken together with similar agreement obtained in an earlier study using two different heat sources will be used as justification for issuing an NBS Certificate (presently in draft) denoting Mound-encapsulated plutonium heat sources as "NBS Special Reference Materials".

[1] American National Standard ANSI N15.22-1975, "Calibration Techniques for the Calorimetric Assay of Plutonium-Bearing Solids Applied to Nuclear Materials Control", American National Standards Institute, Inc., New York, NY.

[2] Ditmars, D.A., "Measurement of the Average Total Decay Power of Two Plutonium Heat Sources in a Bunsen Ice Calorimeter", Int. J. Appl. Rad. Isotop. 27, 469-490, 1976.

Investigators in this portion of the Sub-Task are D.A. Ditmars, J.H. Colwell, M.V. Kilday and D. Bakshi.

#### Sub-Task B: Reference Method Development

##### Resonance Neutron Radiography

A test facility for resonance neutron radiography (a possible NDA reference method) has been established and experiments completed confirming the scientific validity of the method. The apparatus is shown in Fig. 1.

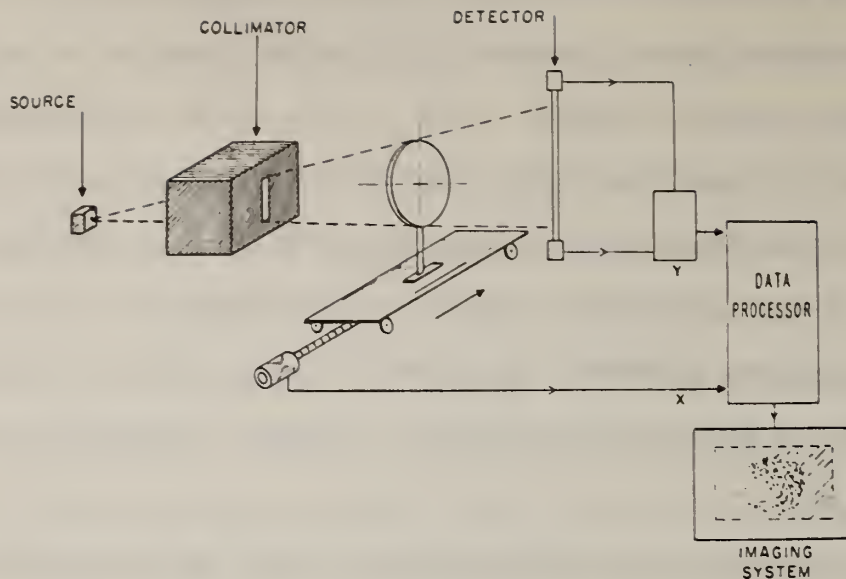

Fig. 1 Resonance Neutron Radiography System. The neutrons from a pulsed source are collimated into a fan-shaped beam to illuminate the position sensitive detector. The object to be radiographed is passed through the beam to generate an image by means of a data processing system.

A pulsed neutron beam spread over a wide band of neutron energy is collimated into a narrow vertical slit. This beam passes through an object to be measured and the transmitted intensity is detected in a position-sensitive detector. The object under study is moved in the horizontal position by a precision-driven tray. The data on position of the tray (x-direction) and position of neutron detection (y-direction) are fed into a data processor. This system processes the data to form pictures for particular neutron energies of interest. The neutron energy is determined by measuring the time-of-flight of the neutron between source and detector. The method takes advantage of the unique resonance structure characteristic of a given isotope of a given element and therefore can determine the position distribution with both elemental and isotopic selectivity. By performing the appropriate analysis, a quantitative measure of the total mass of a particular element or isotope can be determined.

Testing of the method with nuclear material involves problems with the acquisition and handling of suitable samples which only recently have been solved. A preliminary test was therefore devised of a nonradioactive sample shown in Fig. 2. A brass disk was machined to contain a stainless steel disk in the manner shown and the two were bonded together by silver solder. The solder was omitted from about a 20° sector of the full circle. The objective of the experiment was to determine the distribution of the silver solder and to measure the thickness.

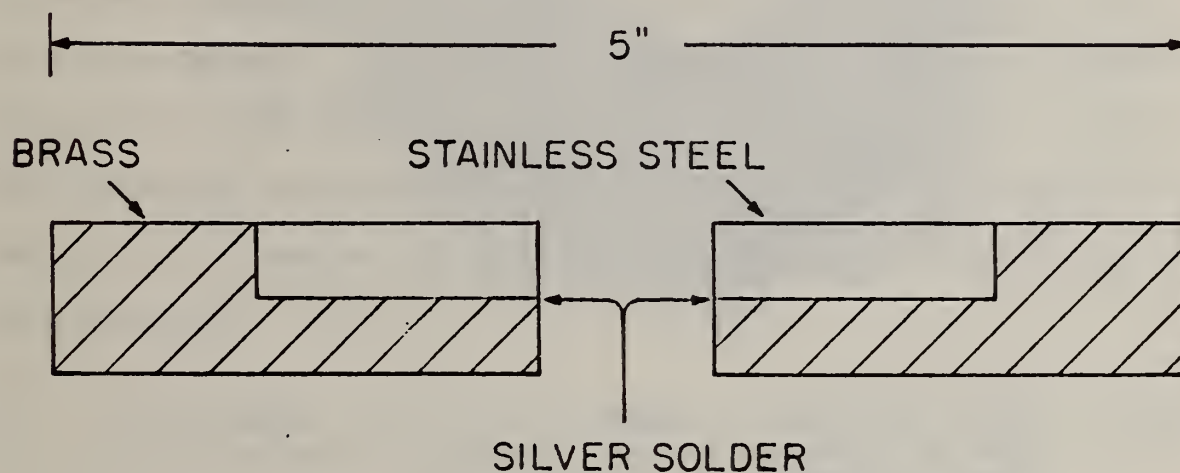

Fig. 2 Cross Section of Silver Solder Sample. Two discs, one brass and one stainless steel, were silver soldered together. A defect was deliberately introduced in the soldering.

The results of the measurement are shown in Fig. 3. The inner light region is the inner hole of the disc and the outer shaded region represents the silver solder. In spite of some "noise", it is clear that the distribution of the silver was not uniform and the  $\sim 20^\circ$  sector is clearly visible. The thickness of the silver in the more uniform regions averages about 0.03 mm. These results were obtained by use of the 5 eV resonance of the isotope  $^{109}\text{Ag}$ . The resolution is about 5 mm.

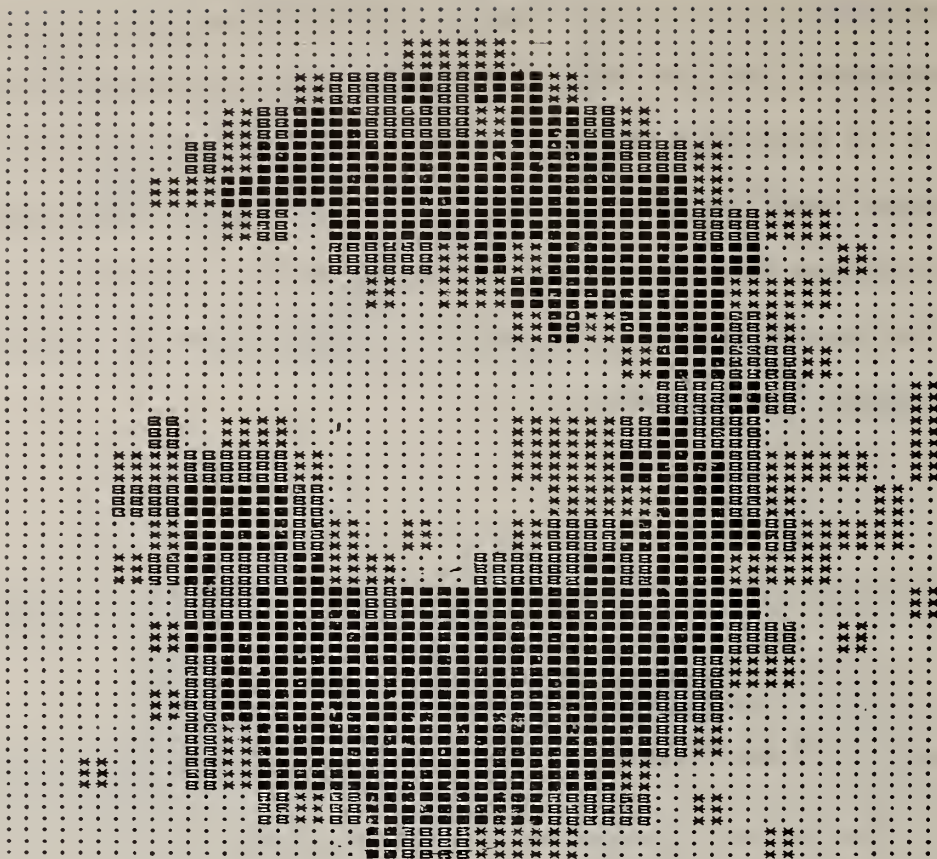

Fig. 3 Neutron Radiograph of Silver Solder Joint. Darkened area shows distribution of silver. Defect in soldering is clearly visible.

With this demonstration of the method, our attention has turned to other factors relating to implementation for nuclear materials. Suitable samples are, of course, required. We have acquired fuel pins from the ANL and General Electric in Wilmington, NC. In addition, a large number of NBS SRMs are available. Progress also was made on the automatic data collection and processing equipment for this facility. For some types of materials, such as fuel pins, better position resolution would be helpful. An NBS staff member, working in collaboration with a group at Oak Ridge National Laboratory (ORNL) on a new neutron detector, had preliminary results indicating a position resolution of 1 mm or better. This should be entirely adequate for this project.

Data collection and analysis of commercial reactor fuel pellets by neutron radiography was carried out. The long time required for data collection was addressed by studies of improved methods of data collection utilizing two-dimensional detector and high speed data storage systems as well as possible methods of increasing neutron flux. Improved techniques of neutron flux generation would be especially important in adapting the laboratory techniques to field methods.

The development of the reference measurement system using resonance neutron radiography continued with the analysis of a fresh fuel rod pellet. The isotopic abundance of the  $^{235}\text{U}$  was measured with an accuracy of 1.5%. The absolute abundance of  $^{235}\text{U}$  and  $^{238}\text{U}$  isotopes was obtained by analysis of the neutron absorption spectrum in the 5 to 15 eV region. Table 3 shows the results obtained by neutron radiography for the isotopic composition of nuclear fuel pellets as compared with measurements made by radiochemical methods by the manufacturer.

TABLE 3  
Assay of Nuclear Fuel Pellet

	Atom Per Cent Content of $^{235}\text{U}$	
	Neutron Radiography	Radiochemistry
Pellet A	4.01 $\pm$ 0.08	3.96 $\pm$ .005
Pellet B	1.10 $\pm$ 0.06	1.19 $\pm$ .005

The high resolution position-sensitive detector developed in collaboration with ORNL has been used to make resonance neutron radiography measurements on commercial reactor fuel pellets (enriched to 4%  $^{235}\text{U}$ ) with LINAC-produced neutrons.

The resolution of the radiographs was about 1 mm, which is better by a factor of 5 than was previously attainable. The collaboration with ORNL is continuing in the development of a two-dimensional position-sensitive detector with high resolution and sensitivity that should permit a marked decrease in the time required to produce a radiograph.

Experimental work on determining possible chemical state effects in neutron standards is continuing. Measurements of the response of  $^{10}\text{B}$  detectors using  $\text{BF}_3$  and elemental solid boron, and measurements comparing  $^{10}\text{B}$  detectors and  $^6\text{Li}$  glass detectors are being carried out to try to determine if chemical state effects are the basis of discrepancies that have been noted between measurements made using these detector systems.

Investigators for the resonance neutron radiography portion of this Sub-Task are C.D. Bowman, R.A. Schrack and J. Behrens.

#### Resonance Neutron Tomography

Another major effort in this portion of the Sub-Task is a project to develop the methodology for high-accuracy measurements and establish reference standards using resonance neutron tomography with reactor-produced neutrons.

A nuclear scrap or waste container consisting of a gallon paint can is to be examined by a pencil neutron beam extracted from the reactor core, the NBS double fission ionization chamber [1] will be used to detect the transmitted neutrons, and through the self-indication effect [2] the isotopic content in the scrap or waste will be identified. The results will be reconstructed tomographically and presented both in 3-dimensional plotted form and on a color graphic terminal with a different color for each different fissile isotope, etc.

A count-rate and sensitivity study has been made to help determine the best available beam port position in the reactor to use, the ranges of fissile



sample thicknesses and sizes that might be examined to an acceptable accuracy, and the time needed to gather data.

An example of the preliminary results is presented in Figure 4 in which fission detector responses for Pu-239, U-235 and U-233 are plotted against fissile sample thickness. The count-rates were normalized to the no-sample response for each detector. The self indication effects are evident in Pu-239 and U-233, while the effect in U-235 was smeared because all neutrons above 0.2 eV were transmitted. The irradiating neutron beam could first be filtered by a thick Pu-239 filter to remove the large 0.3 eV resonance in a Pu-239 detector. This would enhance the U-235 over the Pu-239 by a factor  $\sim 6$ . The same type of technique could also be applied to improve the self-indication of other fissile isotopes. The self-indication effect decreases drastically as the sample gets smaller compared to the detector; in order to assure reasonable counting rates, the detector should be  $\sim 2$  cm in diameter.

By utilizing the self-indication effect for each different isotope, one can then nondestructively analyze an unknown sample made of U-233, U-235, U-238 and/or Pu-239. The equation of self-indication effect for individual isotope sample indicates that the detector response,  $S_k$ , is proportional to the energy sum of the product of  $\phi(E)$ , the transmitted neutron flux, and  $\sigma_{F_k}(E)$ , the fission cross section of detector material, k, i.e.

$$S_k \propto \int \phi(E) \sigma_{F_k}(E) dE = \int \phi_0(E) e^{-\sigma_T(E)X} \sigma_{F_k}(E) dE \quad (1)$$

where  $\phi_0(E)$  is the initial neutron flux,  $\sigma_T(E)$  is the total macroscopic cross section of sample isotope, and X is the thickness of that sample.

Equation 1 enables the calculation of  $\phi(E)$ , apart from a yet to be determined normalization constant, from the measured detector response  $S_k$  and known values of  $\sigma_T(E)$ 's and  $\sigma_{F_k}(E)$ 's. The relative  $\phi(E)$  vs. E curve can be derived with different sample and detector material combinations and thus lends itself

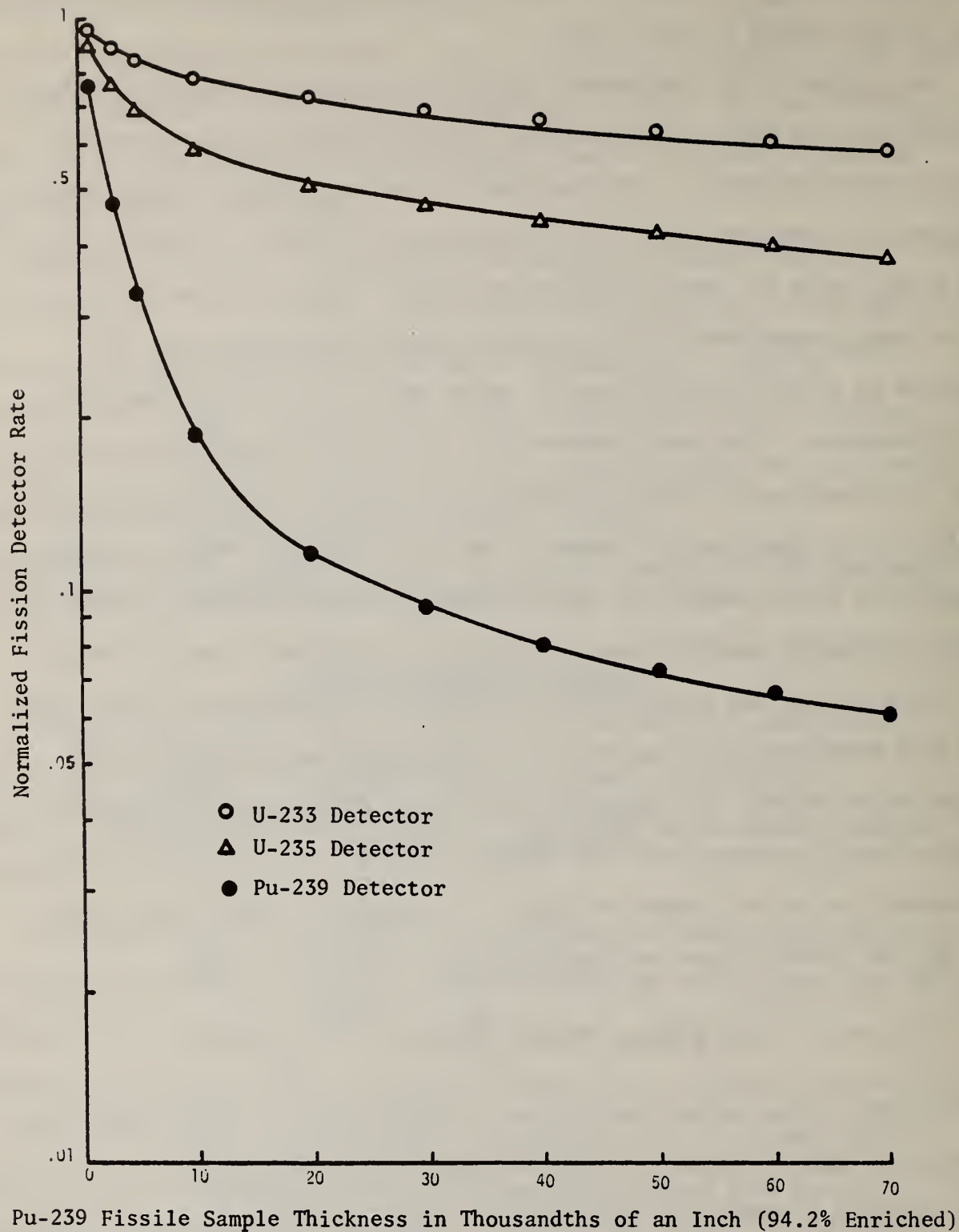

Fig. 4 Normalized Fission Count-Rate as a Function of Pu-239 Fissile Sample Thickness

to easy cross checking. However, the best sensitivity will be obtained when one uses the same material for both sample and detector. Furthermore, the relative  $\phi(E)$  vs.  $E$  curve can be checked with that obtained using other methods [3]; this provides an independent way of beam characterization and a chance to evaluate the self-indication technique as a whole.

A collection of highly enriched ( $\geq 95\%$ ) samples U-233, U-235, U-238 and Pu-239 in the form of metallic disks and with thicknesses ranging from 0.13 to 6.86 mm (0.005 to 0.270 in) will be obtained for our use.

Once this calibration for the detecting system using known sample types and thicknesses has been established, one can then attempt to differentiate and quantify among U-233, U-235, U-238 and Pu-239 in an unknown sample.

Equation 1 for mixed composition sample becomes

$$S_k \propto \int \phi_0(E) e^{-\sum_{i=1}^4 \sigma_{T_i}(E)X_i} \sigma_{F_k}(E) dE \quad (2)$$

where  $i$  can be U-233, U-235, U-238 and Pu-239 and  $k$  will be U-233, U-235, Pu-239 or Pu-241 because the fission cross section of U-238 is very small.

If  $\sigma_{T_i}(E)X_i < 1$  and we drop 3rd and higher order terms (the effect of dropping 3rd and higher order terms in the series expansion is small; since the average values for  $\sigma_T(E)$  are less than  $2 \times 10^{-22} \text{ cm}^2$  and if we assume a typical sample thickness of 0.64 mm (0.025 in), the effect will only be  $\sim 0.7\%$ ),

Equation 2 becomes

$$S_k \propto \int \phi_0(E) e^{-\sum_{i=1}^4 \sigma_{T_i}(E)X_i} \sigma_{F_k}(E) dE$$

$$\approx S_k^0 - \sum_{i=1}^4 K_{ik} X_i + \sum_{i=1}^4 L_{ik} X_i^2 + \sum_{i \neq j} M_{ijk} X_i X_j \quad (3)$$

where  $S_k^0 \equiv \int \phi_0(E) \sigma_{F_k}(E) dE$ ;  $K_{ik} \equiv \int \phi_0(E) \sigma_{T_i}(E) \sigma_{F_k}(E) dE$ ;

$L_{ik} \equiv 1/2 \int \phi_0(E) \sigma_{T_i}^2(E) \sigma_{F_k}(E) dE$ ; and  $M_{ijk} \equiv \int \phi_0(E) \sigma_{T_i}(E) \sigma_{T_j}(E) \sigma_{F_k}(E) dE$ .

$S_k^0$  is proportional to the detector response with no sample and the values of  $K_{ik}$  and  $L_{ik}$  can be extracted from the series expansion of Equation 1 for each unmixed sample.  $M_{ijk}$  can be calculated from the  $\phi(E)$  vs.  $E$  curve and known values of  $\sigma_{T_i}(E)$ ,  $\sigma_{T_j}(E)$  and  $\sigma_{F_k}(E)$ . We apply Equation 3 to each different fission detector looking over the same unknown sample. A computer program will be written to solve these multiple equations for the various  $X$ 's.

The kind of nuclear scrap and waste we are proposing to study can generally be separated into two types. The first type is the lightly contaminated materials in which the density contrast is low; the other type consists of scraps and chips of fissile materials. The reason for such categorization is that the most suitable mathematical reconstruction techniques can then be employed to satisfy the diverse requirements, e.g. speed of computation, accuracy, etc. The filtered back projection algorithm [4] will be used on the first type. The Iterated Algebraic Reconstruction Technique (IART) [5,6] which has been successfully applied to fuel bundle assembly scanning [7] is used for the second type and for the first type when certain shortcomings come into question. The filtered back projection algorithm has been installed on the VAX-11/780 computer, and it has been tested with a very high contrast environment - a delta function. The Iterative Algebraic Reconstruction Algorithm is being installed on the computer. The two algorithms will be systematically examined and combined with the previous count-rate and sensitivity study to simulate the on-line data taking process.

Considerable manpower effort has been expended during the past year in the design of the vertical wide-band resonance neutron facility which would serve the Resonance Neutron Tomography System for the Office of Measurements

for Nuclear Technology, and at the same time serve the NBS Resonance Neutron Radiography Project for materials studies utilizing a wide energy band source of neutrons. The two most important factors considered were those of providing access to other experimental ports without removing the system during reactor operation and the minimizing of radiation leakage to operations personnel during system operation. The system has been designed so that the first factor has been resolved and additional modularized radiation shielding can be added to the proposed system if necessary for background reduction.

- [1] Grundl, J.A., Gilliam, D.M., Dudey, N.D., and Popek, R.J., Nucl. Technol. 25, 237 (1975).
- [2] Menlove, H.O., Tesche, C.D., Thorpe, M.M., and Walton, R.B., Nucl. Appl. 6, 401 (1969).
- [3] Barton, J. and Klozar, M., Materials Evaluation V. 31, No. 9, 1969 (1973).
- [4] Snyder, D.L. and Cox, J.R., Jr., Reconstruction Tomography in Diagnostic Radiology and Nuclear Medicine (University Park Press, Baltimore, MD, 1977), p. 3.
- [5] Gordon, R. and Herman, G.T., Int. Rev. Cytol. 38, 111 (1974).
- [6] Herman, G.T., Lent, A., and Rowland, S.W., J. Theor. Biol. 42, 1 (1973).
- [7] Barton, J., IRT Corp., San Diego, CA, private communication.

The investigators on the resonance neutron tomography portion of the Sub-Task are D.A. Garrett, Y.T. Cheng and M. Ganoczy.

#### Sub-Task C: NDA Calibration Methodology

NBS is conducting investigations of chemical effects on nuclear reactions which might influence the interpretation of measurements, improve the accuracy of detectors, or lead to more accurate new measurement on the capture cross section of  $^{238}\text{UF}_6$  gas. A major emphasis has been on the detection of such effects in the detector gas  $^{10}\text{BF}_3$ .  $^{10}\text{BF}_3$  gas counters have been the most

frequently used neutron detectors for many years. The present calibration techniques used with these detectors may be in error because of the effect induced by the dissociation of the  $\text{BF}_3$  molecule. Both theoretical and experimental work have been carried out with several experiments performed at NBS on the Linac and the nuclear reactor. Experiments also have been carried out at the ORNL linear accelerator. Measurements of the response of  $^{10}\text{B}$  detectors using  $\text{BF}_3$  and elemental solid boron, and measurements comparing  $^{10}\text{B}$  detectors and  $^6\text{Li}$  glass detectors have been carried out to try to determine if chemical state effects are the basis of discrepancies that have been noted between measurements made using these detector systems. This problem has elicited great interest and has great potential impact.

Having demonstrated already the influence of molecular vibrations [1] on nuclear cross sections, studies are now underway to examine the degree of control which might be available as a result of molecular pumping.

It is commonly believed that efficient generation of neutrons using electron beams requires electron energies of 30 to 100 MeV. Accelerators required to supply such high energy electrons are large and costly and not suitable for field methods. Studies recently completed at NBS show that a copious neutron source can be made using electron beam energies of 10 MeV together with a proper arrangement of tungsten and deuterium as a target. A one-section LINAC can therefore be used as a suitable neutron source. Such accelerators can now be made to operate with low maintenance and in a small space and are therefore potentially useful for field use for active neutron interrogation. Such systems should have greatly increased neutron yield over earlier LINAC-based systems used for Safeguards purposes.

- [1] C.D. Bowman and R.A. Schrack, The Influence of Vibrations of Gas Molecules on Neutron Reaction Cross Sections, submitted to Physical Review.

The investigators for this portion of the Sub-Task are C.D. Bowman and R.A. Schrack.

A Segmented Gamma Scan Unit to be used in the analysis of SNM in scrap and waste cans was constructed in the NBS Shops. The unit will be evaluated during FY 80 and will be used in the NBL-NDA Reference Material Evaluation Program for Scrap and Waste, which is scheduled to begin later this year. Hardware and software will be developed to interface the unit into the computer-based analyzer.

The investigator for this portion of the Sub-Task is B. Stephen Carpenter.

### TASK III: STANDARDIZATION OF BULK MEASUREMENT TECHNOLOGY IN NUCLEAR FUEL CYCLE PLANTS

This Task provides standardization for bulk measurements (mass, volume, density, flow, pressure and temperature) of nuclear fuels. Bulk measurements play a very important role in the accountability of SNM and in the safeguarding of SNM against diversion. The standardization provided by this Task will assist inspectors and licensees in implementing efficient measurement systems and will allow licensees and inspectors to make the measurements traceable to national standards.

#### Sub-Task A: Process Tank Volume Measurements Standardization

The major effort in this Sub-Task is directed toward the application of state-of-the-art instrumentation and volumetric transfer standards to the determination of the volume of process tanks and columns to sufficient levels of accuracy.

A paper by F.E. Jones, "The Application of an Improved Calibration System to the Calibration of Accountability Tanks", was presented by a rapporteur at the IAEA International Symposium on Nuclear Materials Safeguards, Vienna, Austria, October 2-6, 1978. The paper summarized the results

cycle facility using state-of-the-art pressure measurement instrumentation and volumetric transfer standards, and techniques developed at NBS. A paper, "Facts and Fallacies of Process Tank Calibration", by J. Whetstone, P. Pontius, and S. Baker, with an appendix by C. Spiegelman and J. Lechner, was presented at the Annual Meeting of the Institute for Nuclear Materials, Albuquerque, NM, July 16-19, 1979.

A Tank Volume Calibration Workshop was held at the DOE/E.I. duPont de Nemours and Co., Inc., Savannah River Plant (SRP) at Aiken, SC on May 17, 1979, at the time of the calibration of a dissolver hold tank for uranium solutions. The Workshop gave participants from industry and Government the opportunity to observe the actual calibration of a tank and to discuss equipment and procedures in detail with the people who conducted the calibration. Two NRC Headquarters people, a resident inspector and an employee of a licensee were among the participants.

A first draft report on the study of the bubbler tube liquid level measurement system, "The Time Dependence of Pressure in a Bubbler Tube", by A. Gaigalas and B. Robertson, has been reviewed and a second draft is being prepared. The report describes tests and results directed toward the generation of pressure traces that are more simply "read" by existing pressure instrumentation. Various innovative alterations in bubbler tube tip geometry have been tested in an attempt to grow a larger, flatter, more nearly horizontal bubble and consequently produce a more readily averaged pressure value. A series of tests has been conducted to quantify the performance of the bubbler system. Liquid levels have been determined using water at room temperature and at elevated temperatures. The data analysis has been completed and a first draft report has been written. Additional tests have been suggested to determine subsequent levels of repeatability.



A draft report on algorithm development to utilize surrogate fluid (water, for example) calibrations of accountability tankage has been reviewed. A revised outline has been produced and a second draft is being prepared. New statistical methods for handling tank calibration data have been added.

The investigators on this portion of the Sub-Task are J. Whetstone, P. Pontius, J.F. Houser, B. Robertson, A. Gaigalas and F.E. Jones.

The prototype dynamic volume calibrator, intended for use in making tank volume calibration more convenient, less time-consuming and less subject to operator error, was completed. Testing of the calibrator uncovered additional problems that were solved by planned changes in the piping and valving. Specifically, the tandem turbine meter system could not sustain the extremely rapid valve opening and closing designed into the system for maximizing accuracy. To remedy this situation, new internal parts were procured and installed, with a more gradual method for starting and stopping.

The development of the calibrator was then delayed due to unexpected unacceptable performance of the turbine meter bearings. The operational environment and cycling of the meters had been altered to produce near-ideal conditions. Despite these efforts, however, turbine bearings continued to fail in short periods of time. The meter manufacturer, being unable to account for these failings, suggested changes in the bearing design. The changes were implemented and the new bearings were continuously tested to establish their performance characteristics. The meters successfully passed the established "run-in" testing. Several sets of calibration data were taken and the results for metering repeatability were as expected. The metering repeatability tolerances were found to increase slightly compared to those of the previously-used ball-bearing design. The expected advantage of the new, sleeve-bearing design was longevity.

The calibrator with the manufacturer-suggested changes in turbine design sustained a severe set-back when the sleeve (with a cobalt binder) bearing failed. At the manufacturer's suggestion, a new ball-bearing design (with a "ribbon-type cage") was tried. This installation failed after several weeks of normal operation. After this failure (the ninth set of ball bearings) no further effort was put into testing ball-bearing turbine meters for this unit. The manufacturer then suggested installing a set of turbine meters with carbide sleeve bearings, the carbide having a nickel binder. Because of the repeated failure of turbine flow meter bearings, it was decided to design a back-up metering assembly for use if the new carbide sleeve bearings failed. After surveying the field of commercially available flow meters, magnetic flow meters were selected and purchased for use in this calibrator because (1) their resolution is as good as that of turbine meters, and (2) because they will not succumb to catastrophic bearing failure since they have no bearings. In addition, the ruggedness of the magnetic meters permits using a shut-off valve in place of the diverter valve, which simplified plumbing. This also permitted using the shut-off pulse to eliminate "start-stop" error. Required circuitry was designed and constructed to implement this. Testing was planned and final versions of computer programs were written.

A paper, "Automated Accountability Tank Calibration", by D. Cooper, P. Baumgarten and B. Robertson, was accepted for presentation at the American Nuclear Society Topical Conference on Measurement Technology for Safeguards and Materials Control, Kiawah Island, Charleston, SC, November 26-29, 1979. The investigators on this portion of the Sub-Task are B. Robertson, D. Cooper and P. Baumgarten.

Final reports for the characterization of three pressure transducers from a nuclear facility were completed and copies were sent to the facility.

This work demonstrated the applicability of the NBS pressure transducer characterization service to nuclear safeguards applications. This portion of the Task is complete and future work done for nuclear facilities will be on a reimbursable basis to NBS by the facilities.

The investigator for this portion of the Sub-Task was S. Wood.

Prior to the volume calibration of the dissolver hold tank for enriched uranium solutions at SRP, an experiment was performed which established the feasibility of in-tank determination of the density of nuclear process solutions in the field with a precision competitive with the precision claimed for laboratory determinations. The experiment involved the measurement of the differential pressure,  $\Delta P$ , between two probes separated vertically by a distance,  $h$ , of 25 cm immersed in water in the tank. The ratio of the  $\Delta P$  to the density,  $\rho$ , of the water inferred from the temperature of the water, is a measure of the product  $(gh)$ , where  $g$  is the acceleration due to gravity. The estimate of the relative standard deviation of the mean  $(gh)$ , for 115 measurements, is 2.2 parts in 10,000. The precision would be further improved by the use of a digital voltmeter with a longer integration time. The technique eliminates one error in the laboratory determination of density and minimizes another, provides a value of  $(gh)$  which can be used to infer  $\rho$  from measurements of  $\Delta P$  in tank solutions, involves a sample which is very much larger (by a factor of approximately 100,000) than is conventionally taken for laboratory density measurements, and enables monitoring of the adequacy of stirring of a solution to determine when the solution is sufficiently homogeneous that a sample might be taken for the measurement of the concentration of nuclear material in the solution. A paper, "In-Tank Measurement of Solution Density", by F.E. Jones, F.M. Schoonover and J.F. Houser, was accepted for presentation at the American Nuclear Society Topical Conference on

The investigator for this portion of the Sub-Task is F.E. Jones.

Sub-Task B: UF<sub>6</sub> Cylinder Measurement Assurance Program

The objective of this Sub-Task is the improvement of in-facility weighing of large UF<sub>6</sub> cylinders. The effort involves the implementation of a Measurement Assurance Program (MAP) for the measurement of the mass of UF<sub>6</sub> cylinders, filled with UF<sub>6</sub> or empty. The MAP will provide continually verifiable evidence of performance of the mass measurement process, giving timely and quantitative uncertainty statements for the mass measurements.

The responsibility of administering the UF<sub>6</sub> cylinder Measurement Assurance Program was assigned to E. Johnsen of NBS. Background material was gathered and reviewed, discussions and consultations regarding the establishment of MAPs were conducted, and a series of visits were made to nuclear plant sites and additional visits were arranged. Data obtained from the nuclear plant site visits were compiled and organized for documentation.

A set of standard operating procedures was prepared for use by administrators of mass Measurement Assurance Programs. This document, which has been submitted for review by appropriate NBS personnel, describes: (a) testing assignments and administration, (b) the type and extent of the data to be taken, and (c) the statistical methodology to be applied for the MAP. An essential step in the implementation of the UF<sub>6</sub> Mass Measurement Assurance Program is to encourage facilities that either ship or receive UF<sub>6</sub> to use In-House Standards that have the same shape and volume as the product cylinders.

Furthermore, the mass of the In-House Standards should be determined by using the Replica Mass Standards which are under the jurisdiction of NBS

as the primary standards. The determination of the mass of each In-House Standard should be in accordance with ANSI N15.18, "Mass Calibration Techniques for Nuclear Material Control".

The following facilities were visited in order to determine their interests and concerns:

<u>Organization</u>	<u>Location</u>
Union Carbide	Oak Ridge, TN
Exxon Nuclear	Hanford, WA
Union Carbide	Paducah, KY
Goodyear Atomic	Piketon, OH
Babcock & Wilcox	Apollo, PA
Allied Chemical	Metropolis, IL
Combustion Engineering	Hematite, MO
Kerr-McGee	Gore, OK

Two workshops were conducted to acquaint potential participants with the UF<sub>6</sub> Mass Measurement Assurance Program. The first workshop, held in Atlanta, GA, presented the rationale and benefits of the program. The second workshop, held at NBS, was a hands-on workshop to train personnel in the weighing techniques to be used.

Following the workshops, the UF<sub>6</sub> shippers and receivers were invited to participate in the program. Positive responses were received from General Electric, Westinghouse, Exxon Nuclear, Babcock & Wilcox, Combustion Engineering, Goodyear Atomic, and Union Carbide at Oak Ridge. Consequently, the UF<sub>6</sub> Mass Measurement Implementation Program was in place by September 30, 1979, and the Replica Mass Standard was being prepared for shipment to Oak Ridge. The investigator for this Sub-Task is E. Johnsen.

#### Sub-Task C: Flow Measurement Standardization

The objective of this Sub-Task is to provide flow measurement standardization for nuclear fuel facilities.

The fabrication of the mobile flow prover for calibration of nuclear facility flow measurement systems was completed and NBS received the unit.

Several changes in the trailer system were made. Calibrations of the meters basic to the operation of this system were made for a series of flow tests in the large NBS water flow facility. It was expected that the turbine meter characteristics would duplicate the calibration curves submitted by the manufacturer. It was planned to, initially, use the three-inch diameter turbine meters in the tandem arrangement. However, for larger flows, the four-inch diameter meters were designed to fit compatibly within the mobile prover unit. In this manner the whole prover unit fits compatibly into the longer range NBS efforts to establish a Measurement Assurance Program for flow. The four-inch turbines have been used to conduct several round-robin tests among flow laboratories both domestically and internationally. The calibration of the tandem turbine meters occurred as scheduled. The unit was reassembled and scheduled for a fully operational test before leaving NBS for testing in the field at a nuclear facility.

The scheduled testing of the assembled mobile prover was begun at NBS. It was found that purging the newly-filled unit of trapped air could be difficult under conditions prevailing at field sites. For this reason a significant change in the piping circuit was designed and fabricated. The personnel at the first field site scheduled for testing were notified of the slight delay in the arrival of the unit.

Testing of the mobile prover was completed after the air purging problems in the unit were eliminated. The field test was scheduled, successfully carried out, and the unit left temporarily for use at the site by plant personnel. The results of this field site calibration of the waste water meters are in process and are scheduled to be submitted to the plant. That the test was conducted will be reported through INMM literature to the nuclear community and response will be awaited.

The investigators for this Sub-Task are J. Whetstone, J. Heine and J.F. Houser.

This Task applies mathematics and statistics to the nuclear safeguards mission of NRC. Mathematics and statistics are needed to (a) formulate valid yet simple step-by-step procedures for meeting NRC material-accounting regulations, (b) optimize the measurement protocols that are part of Measurement Assurance Programs (MAPs), and (c) design experiments and interpret data.

Three types of delivery mechanisms are used in this Task: direct, self-contained pieces of work (Sub-Task A); collaboration with Bureau scientists on other tasks being performed for NRC (Sub-Task B); and interaction with the Safeguards community outside NBS and NRC (e.g. participation in ASTM and INMM activities, Sub-Task C).

Sub-Task A: Development and Standardization of Statistical Procedures for the Safeguards Community

This Sub-Task encompasses the statistical interactions between NBS and Safeguards-related groups.

Work with the Safeguards community this year included ASTM Committee C26 work: a  $\text{PuO}_2$  sampling standard, by-laws, definitions of terms, and discussion of the ASTM "quality systems" initiatives; beginnings on a  $\text{UO}_2$  standard; reviews of several standards for subcommittees of C26; and attendance at one meeting of the Committee. Also, for ANSI N15/INMM 9.4, careful review of a draft standard on measurement control for NDA processes was accomplished, and the annual INMM meeting at Albuquerque, NM was attended. A paper on tank calibration presented at that meeting contained an appendix on the statistics involved written by the Applied Mathematics Group.

The SALE Steering Committee has not met but will be meeting in December of 1979; Dr. Ku, a member from NBS, will be attending. During the

The SALE Steering Committee has not met but will be meeting in December of 1979; Dr. Ku, a member from NBS, will be attending. During the year, comments on the contents, approach, and format of the SALE reports were transmitted to the responsible group at the New Brunswick Laboratory (NBL).

NRC Regulatory Guide 5.58, Considerations for Establishing Traceability of Special Nuclear Material Accounting Measurements, was reviewed in depth, and comments were sent to NRC. In addition, NBS staff had a brief consultation on statistical procedures with NRC/NMSS staff.

Dr. A.J. Goldman, then head of the Operations Research Division at NBS, served on a peer review group for NRC, which investigated the applicability of game theory methods to safeguards and security. The final report of that group has been issued.

The investigators for this Sub-Task are J. Lechner, C. Spiegelman, H. Ku and C. Reeve.

#### Sub-Task B: Facility Error Analysis Study

This Task was initiated in early 1979 with initial efforts directed toward the establishment of an acceptable plan and the identification of an appropriate facility for the first phase of the study. The facility was chosen and six visits were made; in addition, the head of Statistics at the facility made two visits to NBS. A fair understanding of operations at the facility was obtained; a considerable amount of data (both calibration and material) was available for study.

The aim of the first phase of this Task was to identify problem areas in material accounting having to do with the correct assessment of material balances and their uncertainties. This has been accomplished at the subject facility. Results are being documented in reports now being written. These reports will also present avenues of attack to eliminate generic problems found.



It is clear that the assessment of quality of measurements is of prime importance. Problems associated with the assessment will be elucidated in reports being prepared.

Some considerable thought has been given to the next step in this work. The goal is to produce better methods of accomplishing nuclear material accounting, which might be used in modified regulations; and also to present these methods in a way suitable for use in tutorials. This will require generalization of the results found, as well as generation of effective solutions and clear explanations of those solutions.

Investigators for this Sub-Task are J. Lechner and W. Liggett.

#### Sub-Task C: Statistical Support for Other NBS Tasks

The volume calibration effort at NBS has involved the Applied Mathematics Group in several ways: analyzing data from actual calibration exercises; developing methods which are capable of providing supportable statistical inference statements; cooperating with research efforts involving experts from the academic community to develop still better ways; and participation in the standards-writing activities of ANSI/INMM committees. The calibration methods originated by H. Scheffé, now being developed by several NBS statisticians, are being prepared for publication in the statistical literature; a paper will be presented at the Conference on Applied Statistics this December, and submitted for publication. A more practically-oriented paper is being prepared for Nuclear Materials Management. The appendix of a paper presented at the INMM meeting was devoted to the statistics of the new approach. Refinements, and the development of computer programs to carry out the procedure, are proceeding; it is hoped to use some of these in the ANSI Standard N15.19, now being revised.

A related effort at NBS concerns the possible use of flowmeters to provide "dynamic" calibration of a process tank. The Applied Mathematics Group has been assisting in the modeling and data-analysis portions of this Task.

A Measurement Assurance Program for the mass of large UF<sub>6</sub> cylinders is being set up; Applied Mathematics has been involved in the discussions pertaining to this program and will continue to be involved in setting it up and in data analysis.

A new <sup>233</sup>U SRM is being established; this has required assistance with experimental design, and will require data analysis to establish the uniformity and the appropriate uncertainty limits for the material.

International U<sub>3</sub>O<sub>8</sub> standards, under development, have required analysis of extensive amounts of data. This has involved innovative approaches to cull from the whole mass an appropriate subset for analysis. One statistician participated in meetings at the Geel Laboratory on this standard.

A meeting at Barnwell to review safeguards procedures was attended by one statistician.

Initial collaboration was begun on several NDA techniques being investigated at NBS: resonance neutron radiography, and neutron tomography.

Investigators for this Sub-Task were M. Cordes, H.H. Ku, J. Lechner, W. Liggett, C. Reeve, C. Spiegelman, J. Sacks (Rutgers University) and W. Sludden (Purdue University).

#### TASK V: USERS GUIDE, SAFEGUARDS ACCOUNTABILITY INSTRUMENTATION AND TECHNIQUES

The primary objective of the Users Guide is to provide specific recommendations on how facilities should be designed to accommodate the necessary measurements to meet the SNM accountability goals of the safeguards program. The guide will discuss how the measurement instruments and accountability systems should be installed and will outline the supporting services required.

The guide will also discuss facility design considerations so that the instruments can be efficiently calibrated, operated and repaired, either manually or remotely.

The preparation of a planning document to define the task of writing a "Handbook for Facility Design to Meet Safeguards Accountability Requirements", which was started during the fourth quarter of FY 1978, was continued this quarter. During the last week in November 1978, visits were made to General Electric facilities in San Jose, and the Bechtel Power Corp. office in San Francisco, to discuss their views on how the manual should be prepared to be of most use to their staffs. Additional background information was obtained during the first week of December by attending the "In-Plant Nondestructive Assay Instrumentation" course at Los Alamos. These visits revealed that most of the accountability instruments and techniques for safeguards purposes are in a continuing state of development or improvement and that this dynamic situation complicates the task.

In addition, a meeting with NRC representatives during December 1978 resulted in a decision that NBS will prepare a Users Guide which will be intended for use by NRC licensing and inspection personnel, and Architect-Engineers responsible for the design of facilities to accommodate measuring equipment.

As a result of a meeting with representatives of NRC in February 1979, the Guide will emphasize the practical aspects of setting up and operating measurement systems. It is estimated that the guide will be 140 pages in length and will cover measurement of volume, flow and mass, active and passive nondestructive assay (NDA) systems, isotopic determination and destructive assay systems, and operation in a hostile environment. A detailed topic sentence outline was prepared.

Following an NRC review of the synopsis of the Guide, certain revisions were made to focus the discussion on facility design features that would improve the operations and effectiveness of the safeguards measurement instrumentation systems. A preliminary draft of the Guide was prepared during this quarter, but it is expected that the draft will be revised to incorporate the information that will be obtained during the visits to NRC licensees and DOE contractors during the next quarter.

The preparation of the Users Guide met the schedule set forth in the initial project plan. A first draft was prepared by September 30, 1979. Data and information used in the preparation of the first draft were acquired by visiting the following facilities: AGNS, Barnwell; Savannah River Lab; Bechtel, San Francisco; Rocky Flats Plant; LLL; LASL; ICPP, Idaho; and Westinghouse, Columbia. Additional information was obtained by attending the INMM Annual Meeting in Albuquerque, NM. The investigator for this Task is E. Johnsen.

U.S. DEPT. OF COMM. BIBLIOGRAPHIC DATA SHEET	1. PUBLICATION OR REPORT NO. NBSIR 80-2033	2. Gov't. Accession No.	3. Recipient's Accession No.
4. TITLE AND SUBTITLE Measurements and Standards for Nuclear Materials Safeguards (Annual Report--Fiscal Year 1979)		5. Publication Date May 1980	
7. AUTHOR(S) B. S. Carpenter and F. E. Jones, Editors		8. Performing Organ. Report No.	
9. PERFORMING ORGANIZATION NAME AND ADDRESS NATIONAL BUREAU OF STANDARDS DEPARTMENT OF COMMERCE WASHINGTON, DC 20234		10. Project/Task/Work Unit No. 11. Contract/Grant No. AT(49-25)-9009	
12. SPONSORING ORGANIZATION NAME AND COMPLETE ADDRESS (Street, City, State, ZIP) Office of Standards Development U.S. Nuclear Regulatory Commission Washington, DC 20555		13. Type of Report & Period Covered Annual--Fiscal 1979 14. Sponsoring Agency Code	
15. SUPPLEMENTARY NOTES  <input type="checkbox"/> Document describes a computer program; SF-185, FIPS Software Summary, is attached.			
16. ABSTRACT (A 200-word or less factual summary of most significant information. If document includes a significant bibliography or literature survey, mention it here.)  This report is a review of the progress made during Fiscal Year 1979 (October 1, 1978 through September 30, 1979) of a long-term NBS program sponsored by the Nuclear Regulatory Commission (NRC) to upgrade national measurements and standards capability for nuclear materials safeguards. The Nuclear Regulatory Commission sponsored program at NBS is a synergistic part of the overall NBS program in this area which is sponsored jointly by the Nuclear Regulatory Commission, the Department of Energy, and the Department of State (ISPO). A summary of the progress for each of the five NRC-supported Tasks in the project is given.			
17. KEY WORDS (six to twelve entries; alphabetical order; capitalize only the first letter of the first key word unless a proper name; separated by semicolons) Accountability; accuracy; analytical chemistry; calorimetry; gamma spectrometry; mass spectrometry; nondestructive assay; nuclear safeguards; precision; reference materials; special nuclear materials.			
18. AVAILABILITY <input type="checkbox"/> Unlimited <input checked="" type="checkbox"/> For Official Distribution. Do Not Release to NTIS  <input type="checkbox"/> Order From Sup. of Doc., U.S. Government Printing Office, Washington, DC 20402, SD Stock No. SN003-003-  <input type="checkbox"/> Order From National Technical Information Service (NTIS), Springfield, VA. 22161		19. SECURITY CLASS (THIS REPORT) UNCLASSIFIED	21. NO. OF PRINTED PAGES 51
		20. SECURITY CLASS (THIS PAGE) UNCLASSIFIED	22. Price

