

Roundabouts



U.S. Department of Transportation
Federal Highway Administration

FHWA-SA-10-006



Safe Roads for a Safer Future
Investment in roadway safety saves lives

Foreword

This technical summary is designed as a reference for State and local transportation officials, Federal Highway Administration (FHWA) Division Safety Engineers, and other professionals involved in the design, selection, and implementation of roundabouts. Its purpose is to provide an overview of safety considerations in the design, implementation, and operation of roundabout intersections in urban, suburban, and rural environments where design considerations can vary as a function of land uses, travel speeds, volumes of traffic by mode (e.g., car, pedestrian, or bicycle), and many other variables.

This technical summary explores the characteristics of modern roundabouts while reinforcing the need to apply a principles-based approach to design. It provides readers with an overview of the key considerations for planning, analysis, and design of single-lane and multilane roundabouts. Section 1 of this document summarizes the characteristics of roundabouts. Section 2 presents benefits of roundabout intersections compared to traditional signalized and/or stop-controlled intersections. Sections 3-6 provide an overview of user, location, operational and design considerations respectively.

The information presented in this summary outlines the principles described in the FHWA document Roundabouts: An Informational Guide [1] and the forthcoming 2nd Edition [2] of that document (hereafter referred to as the Roundabout Guide), which is in progress at the time of this writing and due to be published in 2010. Specific considerations for mini-roundabouts are summarized in a separate FHWA document titled Mini-Roundabouts Technical Summary [3]. Figures are from the Roundabout Guide unless otherwise noted.

This publication does not supersede any publication; and is a Final version.

Disclaimer and Quality Assurance Statement

Notice

This document is disseminated under the sponsorship of the U.S. Department of Transportation in the interest of information exchange. The U.S. Government assumes no liability for the use of the information contained in this document.

Quality Assurance Statement

The Federal Highway Administration (FHWA) provides high-quality information to serve Government, industry, and the public in a manner that promotes public understanding. Standards and policies are used to ensure and maximize the quality, objectivity, utility, and integrity of its information. FHWA periodically reviews quality issues and adjusts its programs and processes to ensure continuous quality improvement.

Contents

Introduction	1
Section 1: Characteristics of Roundabouts	3
Section 2: Benefits of Roundabouts	4
Section 3: User Considerations	5
3.1 Motorists	5
3.2 Pedestrians	6
3.3 Bicycles	6
3.4 Emergency Vehicles	6
Section 4: Location Considerations.	7
4.1 Common Site Applications	7
4.2 Site Constraints	8
Section 5: Operational Analysis	9
Section 6: Design Considerations.	10
6.1 Horizontal Design.	11
6.2 Pedestrian Design Treatments	17
6.3 Bicycle Design Treatments	17
6.4 Sight Distance and Visibility	18
6.5 Vertical Design.	19
6.6 Pavement Markings and Signs.	20

6.7	Lighting	23
6.8	Landscaping	23
6.9	Other Design Details and Applications	24
Section 7:	Costs.	25
Section 8:	References	26

Introduction

Modern roundabouts are a type of intersection characterized by a generally circular shape, yield control on entry, and geometric features that create a low-speed environment. Modern roundabouts have been demonstrated to provide a number of safety, operational, and other benefits when compared to other types of intersections. On projects that construct new or improved intersections, the modern roundabout should be examined as an alternative. This technical summary explores the characteristics of modern roundabouts while reinforcing the need to apply a principles-based approach to design. It provides readers with an overview of the key considerations for planning, analysis, and design of single-lane and multilane roundabouts.

The information presented in this summary outlines the principles described in the FHWA document *Roundabouts: An Informational Guide* [1] and the forthcoming 2nd Edition [2] of that document (hereafter referred to as the Roundabout Guide), which is in progress at the time of this writing and due to be

published in 2010. Specific considerations for mini-roundabouts are summarized in a separate FHWA document titled *Mini-Roundabouts Technical Summary* [3]. Figures are from the Roundabout Guide unless otherwise noted.



Adapted from Photo by Lee Rodegerdtis (used with permission)

Section 1: Characteristics of Roundabouts

Circular intersection forms have been part of the transportation system in the United States for over a century. Their widespread usage decreased after the mid-1950s, as rotary intersections began experiencing problems with congestion and safety. However, the advantages of the modern roundabout, including modified and improved design features, have now been recognized and put to the test in the United States. There are now estimated to be well over a thousand roundabouts in the United States and tens of thousands worldwide, with the number estimated to be increasing in the United States each year.

A modern roundabout has the following distinguishing characteristics and design features:

- Channelized approaches;
- Yield control on all entries;
- Counterclockwise circulation of all vehicles around the central island; and
- Appropriate geometric curvature to encourage slow travel speeds through the intersection.

Figure 1 and Figure 2 illustrate these characteristics and design features, respectively.

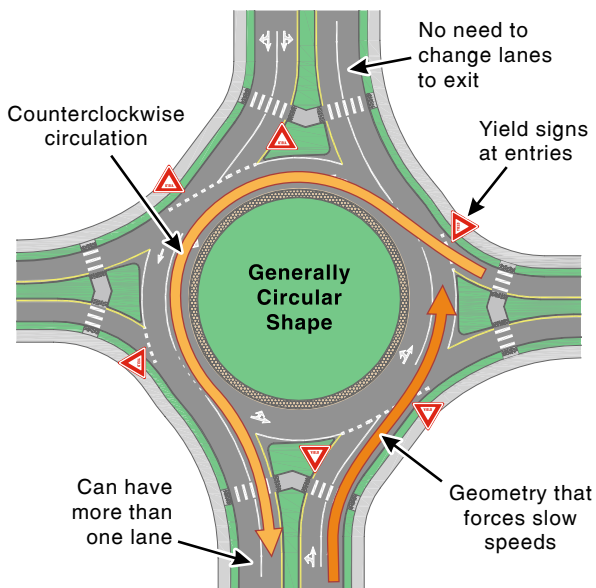

Figure 1: Key Roundabout Characteristics.

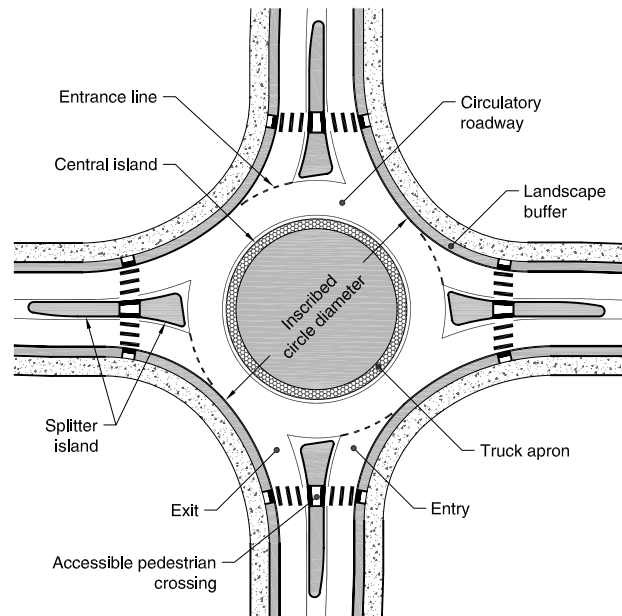

Figure 2: Roundabout Design Features

Roundabouts have been classified into three basic categories according to size and number of lanes to facilitate discussion of specific performance

or design issues: mini-roundabouts, single-lane roundabouts, and multilane roundabouts¹. These are summarized in Table 1.

Table 1: Roundabout Category Comparison

Design Element	Mini Roundabout	Single-Lane Roundabout	Multi-Lane Roundabout
Desirable maximum entry design speed	15 to 20 mph (25 to 30 km/h)	20 to 25 mph (30 to 40 km/h)	25 to 30 mph (40 to 50 km/h)
Maximum number of entering lanes per approach	1	1	2+
Typical inscribed circle diameter	45 to 90 ft (13 to 27 m)	90 to 180 ft (27 to 55 m)	150 to 300 ft (46 to 91 m)
Central island treatment	Fully traversable	Raised (may have traversable apron)	Raised (may have traversable apron)
Typical daily service volumes on 4-leg roundabout below which may be expected to operate without requiring a detailed capacity analysis (veh/day)*	Up to approximately 15,000 veh/day	Up to approximately 25,000 veh/day	Up to approximately 45,000 veh/day for two-lane roundabout

*Operational analysis needed to verify upper limit for specific applications.

Modern roundabouts are different from other types of circular intersections in use in some parts of the United States. Roundabouts are typically smaller than the large, high-speed rotaries still in use in some parts

of the country, and they are typically larger than most neighborhood traffic calming circles. Further discussion can be found in the Roundabout Guide.

Section 2: Benefits of Roundabouts

Roundabouts are becoming more popular based on the multiple opportunities to improve safety and operational efficiency, and provide other benefits. Of course, roundabouts are not always feasible and do not always provide the optimal solution for every problem. The benefits of roundabout intersections, and some constraining factors, are described below.

- Traffic Safety** – Numerous studies have shown significant safety improvements at intersections converted from conventional forms to roundabouts. The physical shape of roundabouts eliminate crossing conflicts that are present at conventional intersections, thus reducing the total number of potential conflict points and the most severe of those conflict points. The most comprehensive and recent study showed overall reductions of 35 percent in total crashes and 76 percent in injury crashes [4]. Severe, incapacitating injuries and fatalities are rare, with one study reporting 89-percent reduction in these types of crashes [5] and another reporting 100-percent reduction in fatalities [6].
- Operational Performance** – When operating within their capacity, roundabouts typically have lower overall delay than signalized and all-way stop-controlled intersections. The delay reduction is often most significant during non-peak traffic periods. These performance benefits can often result in reduced lane requirements between intersections. When used at the terminals of freeway interchanges, roundabouts can often reduce lane requirements for bridges over or under the freeway, thus substantially reducing construction costs. However, as yield-controlled intersections, roundabouts do not provide priority to specific users such as trains, transit, or emergency vehicles.

¹ Please see the Mini-Roundabouts Technical Summary for information on mini-roundabouts.

- **Environmental Factors** – Roundabouts often provide environmental benefits by reducing vehicle delay and the number and duration of stops compared with signalized or all-way stop-controlled alternatives. Even when there are heavy volumes, vehicles continue to advance slowly in moving queues rather than coming to a complete stop. This can reduce noise and air quality impacts and fuel consumption significantly by reducing the number of acceleration/deceleration cycles and the time spent idling.
- **Access Management** – Because roundabouts can facilitate U-turns, they can be a key element of a comprehensive access management strategy to reduce or eliminate left-turn movements at driveways between major intersections.
- **Traffic Calming** – Roundabouts can have traffic calming effects on streets by reducing vehicle speeds using geometric design rather than relying solely on traffic control devices.
- **Pedestrian Safety** – Due to the reduction of vehicle speeds in and around the intersection, roundabouts can improve pedestrian crossing opportunities. Additionally, the splitter island refuge area provides the ability for pedestrians to focus on one traffic stream at a time while crossing. However, pedestrians with visual impairments may not receive the same level of information at a roundabout as at a typical signalized intersection, and they may require additional treatments, such as pedestrian signalization. Specific design treatments for enhancing accessibility for visually impaired pedestrians are receiving continued study [7].
- **Aesthetics** – The central island and splitter islands offer the opportunity to provide attractive entries or centerpieces to communities through use of landscaping, monuments, and art, provided that they are appropriate for the speed environment in which the roundabout is located.
- **Land Use** – Roundabouts can provide a transition area between high-speed rural and low-speed urban environments. They can also be used to demarcate commercial areas from residential areas.
- **Ongoing Operations and Maintenance** – A roundabout typically has lower operating and maintenance costs than a traffic signal due to the lack of technical hardware, signal timing equipment, and electricity needs. Roundabouts also provide substantial cost savings to society due to the reduction in crashes, particularly fatal and injury crashes, over their service life. As a result, the overall life cycle costs of a roundabout can be significantly less than that of a signalized intersection.
- **Approach Roadway Width** – A roundabout may reduce the amount of widening needed on the approach roadways in comparison to alternative intersection forms. While signalized or stop-controlled intersections can require adding lengthy left-turn and/or right-turn lanes, a roundabout may enable maintaining a narrower cross section in advance of the intersection. However, roundabouts usually require more space for the circulatory roadway, central island, and sidewalks than the typically rectangular space inside traditional intersections. Therefore, roundabouts often have greater right-of-way needs at the intersection quadrants compared with other intersection forms.

Section 3: User Considerations

The various user types of a roundabout have unique characteristics that should be considered in the planning and design processes. Some of the characteristics of four primary user groups—motorists, pedestrians, bicyclists, and emergency vehicles—are discussed here; a more complete discussion can be found in the Roundabout Guide.

3.1 Motorists

Research indicates roundabouts address some of the problems drivers experience in dealing with intersections. One of the key design features of a roundabout is the geometric shape of the roundabout that causes all traffic to slow down as it enters the intersection. Roundabouts can enhance the safety for drivers, including older drivers, by:

- Allowing more time to make decisions, act, and react;
- Reducing the number of directions in which a driver needs to watch for conflicting traffic; and
- Reducing the need to judge gaps in fast traffic accurately.

Attention should be paid to the layout of signs and pavement markings to make them clear, visible, and

unambiguous to all users, including older drivers. Trucks and other large vehicles can be accommodated at a roundabout with proper attention to design. Further details on design vehicles are provided later in this technical summary.

3.2 Pedestrians

Pedestrians are accommodated at pedestrian crosswalks around the perimeter of the roundabout. By providing space to pause on the splitter island, pedestrians can consider one direction of conflicting traffic at a time, which simplifies the task of crossing the street. The low vehicular speeds through a roundabout also allow more time for drivers and pedestrians to react to one another and to reduce the consequences of error. As a result, few crashes involving pedestrians have been reported at roundabouts [4].

Pedestrians with vision impairments may have more difficulty crossing roundabouts due to the following key factors:

- Pedestrians with vision impairments may have trouble finding crosswalks because crosswalks are located outside the projection of approaching sidewalks and the curvilinear nature of roundabouts alters the normal audible and tactile cues they use to find crosswalks.
- Roundabouts do not typically include the normal audible and tactile cues used by pedestrians with vision impairments to align themselves with the crosswalk throughout the crossing maneuver.
- The sound of circulating traffic masks the audible cues that blind pedestrians use to identify the appropriate time to enter the crosswalk (both detecting a gap and detecting that a vehicle has yielded).

The Americans with Disabilities Act requires that all new and modified intersections, including roundabouts, be accessible to and usable by people with disabilities. Further discussion on treatments can be found later in this technical summary and in the Roundabout Guide.

3.3 Bicycles

Bicyclists have a broad range of skills and experiences, and roundabouts are typically designed to accommodate that wide range. Bicyclists should be provided similar options to negotiate roundabouts as they have at conventional intersections, where they navigate either as motor vehicles or pedestrians depending on the size of the intersection, traffic volumes, their experience level, and other factors. Bicyclists are often comfortable riding through single-lane roundabouts in low-volume environments in the travel lane with motor vehicles, as speeds are comparable and potential conflicts are low. At larger or busier roundabouts, many cyclists may be more comfortable and safer using ramps connecting to a sidewalk or multiuse path around the perimeter of the roundabout as a pedestrian.

3.4 Emergency Vehicles

Roundabouts provide emergency vehicles the benefit of lower vehicle speeds, which may make roundabouts safer for them to negotiate than signalized crossings. Unlike signalized intersections, emergency vehicle drivers will not encounter through vehicles unexpectedly running the intersection and hitting them at high speed. Emergency services personnel may have some concern about their ability to navigate a roundabout in an emergency vehicle, although this can be readily addressed in design (see the “Design Vehicle” section of this technical summary).

On emergency response routes, the delay for the relevant movements at a planned roundabout should be compared with alternative intersection types and control. As with conventional intersections, motorists should be educated not to enter a roundabout when an emergency vehicle is approaching on another leg. Once entered, they should clear out of the circulatory roadway if possible, facilitating queue clearance in front of the emergency vehicle.

Section 4: Location Considerations

In the planning process for a new or improved intersection where a traffic signal or stop control is under consideration, a modern roundabout should likewise receive serious consideration as an alternative. This begins with understanding the site characteristics and determining a preliminary configuration. There are a number of locations where roundabouts are commonly found to be advantageous and a number of situations that may adversely affect their feasibility. As with any decision regarding intersection treatments, care should be taken to understand the particular benefits and trade-offs for each project site. This section outlines some location considerations to help determine whether a roundabout is a feasible intersection alternative.

4.1 Common Site Applications

The following applications represent some of the situations at which roundabouts are commonly found to be feasible and advantageous (further applications can be found in the Roundabout Guide):

- **New residential subdivisions** – Roundabouts offer a low-speed, low-noise intersection form that requires little ongoing maintenance.
- **Schools** – A primary benefit is the reduction of vehicle speeds in and around the roundabout. Roundabouts improve pedestrian crossing opportunities, providing mid-block refuge and the ability for pedestrians to focus on one traffic stream at a time while crossing with or without crossing guards. Single-lane roundabouts are generally preferable to multilane roundabouts near schools because they offer simpler crossings for children. However, if the traffic volume is sufficiently high, a multilane roundabout may still be preferable to a large signalized intersection.

- **Corridors** – Roundabouts present opportunities to shape the cross section of a corridor in ways that are perhaps different from those afforded by signalized intersections. Signalized intersections operate most efficiently when they manage the advancement of platoons of traffic. This requires sufficient through lanes between signals to maintain the integrity of these platoons. Roundabouts, on the other hand, produce efficiency through a gap acceptance process and thus do not carry the same need for platoon progression. As a result, roundabouts can be made as large as needed for node capacity, keeping the links between nodes more narrow. This concept is sometimes referred to as a “wide nodes, narrow roads” concept. The reduced number of travel lanes between intersections may make it feasible to reduce right-of-way impacts and to accommodate parking, wider sidewalks, planter strips, and bicycle lanes.
- **Interchanges** – Roundabouts often can make more efficient use of the bridge structure between ramp terminals, extending design life or substantially reducing construction costs if improvements are needed.



Photo: Lee Rodegerds (used with permission)

- **Gateway treatments** – Roundabouts present opportunities to create community focal points, landscaping, and other gateway features within an intersection form that is also safe and efficient.
- **Intersections with high delay** – A roundabout can be an ideal application to reduce delay at stop-controlled or signalized intersections.
- **Rural intersections** – Roundabouts have been demonstrated to significantly reduce fatal and injury crash experience at

Figure 3: Roundabout near a School (Clearwater, Florida)

rural, high-crash locations, even those with high-speed approaches (greater than 55 mph).

- **Commercial developments –**

Roundabouts are an aesthetically pleasing design alternative to traffic signals and have the ability to meet similar capacity needs.

4.2 Site Constraints

Certain site-related factors may significantly influence the design requiring that a more detailed investigation of some aspects of the design or operation be carried out. A number of these factors (many of which are valid for any intersection type) are listed below:

- Physical complications such as right-of-way limitations, utility conflicts, environmental constraints, drainage problems, intersection skew, grades or unfavorable topography, etc, that make it politically or economically infeasible to construct a roundabout.
- Proximity of generators of significant traffic that might have difficulty negotiating the roundabout, such as high volumes of trucks or oversized vehicles (sometimes called “superloads”).
- Proximity of other conditions that would require pre-emption, such as at-grade rail crossings, drawbridges, etc.
- Proximity of bottlenecks that would routinely back up traffic into the roundabout, such as over-capacity signals, etc. The successful operation of a roundabout depends on generally unimpeded flow on the circulatory roadway. If traffic on the circulatory roadway comes to a halt, roundabout operation is impeded. In comparison, other control types may be able to serve some movements under these circumstances.
- Intersections where an unacceptable delay to the major road could be created. Roundabouts introduce some



Figure 4: Roundabouts at an Interchange (Vail, Colorado)

Photo: Lee Rodegerds (used with permission)

delay to all traffic entering the intersection, including the major street.

- Heavy pedestrian or bicycle movements in conflict with high traffic volumes that might require supplemental traffic control (e.g., signals).
- Intersections located on arterial streets within a coordinated signal network. In these situations, the level of service on the arterial might be better with a signalized intersection incorporated into the system.

The existence of one or more of these conditions may or may not preclude installing a roundabout. Roundabouts have, in fact, been built at locations that exhibit one or more of the conditions listed above. To address these conditions, additional analysis, design work, and/or coordination with affected parties may be needed to resolve conflicts and help in the decision-making process. In some cases, the conditions identified above cannot be overcome, and another intersection type may be more suitable.

Section 5: Operational Analysis

A basic question that needs to be answered at the planning level is how many entering and circulating lanes a roundabout would require to serve the traffic demand. The number of lanes affects not only the capacity of the roundabout, but also the size of the roundabout footprint. Figure 5 presents ranges of average annual daily traffic (AADT) volumes to identify scenarios under which one-lane and two-lane roundabouts may perform adequately. These ranges represent total entering volume thresholds where a one-lane or two-lane roundabout should operate acceptably and ranges of volumes over which more detailed analysis is required. This procedure is offered as a simple, conservative method for estimating roundabout lane requirements.

If the volumes fall within the ranges identified in Figure 5 where “additional analysis is needed,” a single-lane or double-lane roundabout may still function quite well, but it requires using the procedures described in the following section to obtain a closer look at the actual turning movement volumes during the design hour. Variable-sized roundabouts (e.g., one lane for part of the circulatory roadway, and two lanes at other parts within the same roundabout), roundabouts with peak-period metering, and three-lane roundabouts have been successful in some locations.

The 2010 *Highway Capacity Manual (HCM)* [8] employs a number of models to reflect the capacity of roundabout entries with up to two lanes. The capacity of each entry lane is calculated based on the conflicting traffic flow in the circulatory roadway, which comprises the various turning movements from other approaches that pass in front of (and thus conflict with) the subject entry. Figure 6 shows the capacity curves for various one- and two-lane roundabout scenarios. The lower curve can be used to calculate the capacity of a one-lane entry to a one-lane roundabout, or either lane of a two-lane entry conflicted by one circulating lane. For a roundabout with two circulating lanes, the two curves representing the left and right entry lanes should be used. As an example, for a given circulatory flow rate of 600 passenger cars per hour (pc/h) across two lanes, the left lane of a two-lane entry would have a capacity of approximately 720 pc/h, and the right lane of a two-lane entry

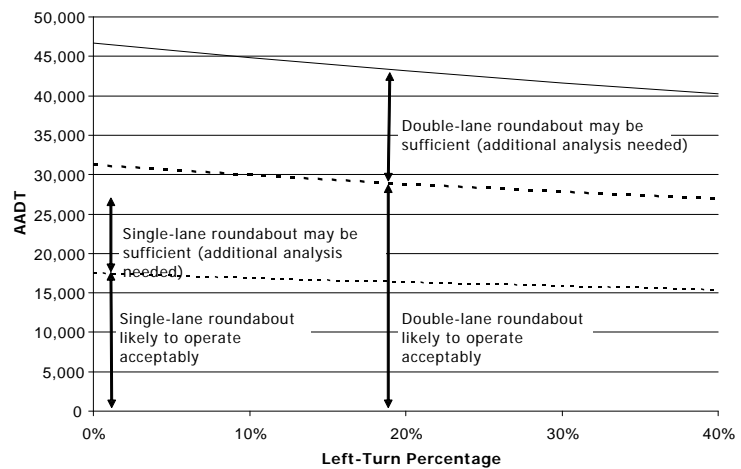

Figure 5: Planning Level AADT Intersection Volumes

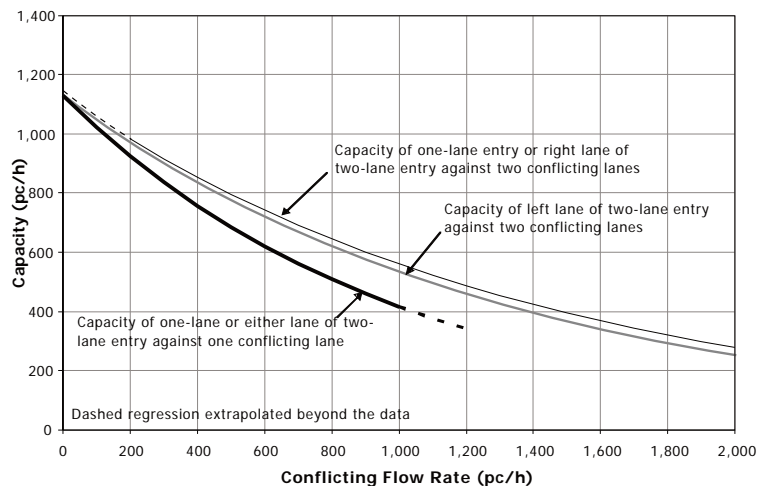

Figure 6: Capacity of Single-Lane and Multilane Entries

Source: 2010 HCM [8]

would have a capacity of approximately 740 pc/h. More detail, including sample calculations of roundabout volumes, conversion of vehicles per hour (veh/h) to passenger cars per hour (pc/h), lane use, capacity, and performance measures, can be found in the 2010 HCM.

Different methods of analysis are available and are in common use for a variety of applications, including software programs with specific roundabout analysis procedures and simulation models. These models

may be capable of analyzing situations beyond the methodologies presented in the 2010 HCM or Roundabout Guide; refer to these documents for further discussion. Regardless of the analytical tools used, it is critical to understand that each model and analysis method makes certain operational and performance assumptions. Along with an understanding of the inherent imprecision of traffic forecasting, this makes the application of engineering judgment crucial in the analytical process.

Section 6: Design Considerations

The geometric design of a roundabout requires the balancing of competing design objectives. Roundabouts operate most safely when their geometry forces traffic to enter and circulate at slow speeds. Poor roundabout geometry has been found to negatively impact roundabout operations by affecting driver lane choice and behavior through the roundabout. Many of the geometric parameters are governed by the maneuvering requirements of the design vehicle and the accommodation of nonmotorized users. Thus, designing a roundabout is a process of determining the optimal balance among safety provisions, operational performance, and accommodation of design users.

This design balance is further influenced by physical, environmental, economic, and political constraints and opportunities, which further increases the variability from site to site. For example, a roundabout that is built to its ultimate configuration on opening day may have different design characteristics from one that is initially built in an interim configuration (e.g., a single-lane roundabout converted later to a double-lane roundabout), and the techniques for those conversions can vary (e.g., adding lanes to the outside versus the inside). For these reasons, roundabout design techniques are difficult to standardize, and there is rarely only one correct or even best way to design a roundabout.

Fundamentally, roundabout design involves achieving the following key objectives:

- **Slow entry speeds** and consistent speeds through the roundabout by using deflection;
- **The appropriate number of lanes** and lane assignment to achieve adequate capacity, lane volume balance, and continuity of lanes through the roundabout;
- **Smooth channelization** that is intuitive to drivers and results in vehicles naturally using the intended lanes;
- **Adequate accommodation for the design vehicles;**

- **A design that meets the needs of pedestrians and bicyclists;** and
- **Appropriate sight distance** and visibility.

Since roundabouts are applied in many different situations and under differing site specific conditions, each roundabout design requires distinctive design choices. The general nature of the roundabout design process is an iterative one. Minor adjustments in geometric design attributes can result in significant effects on the operational and safety performance of the roundabout. Also, many of the individual design components interact with each other, and therefore considering the roundabout design in whole (the outcome of the design) is more important than focusing on the isolated components. Because of this iterative process, it may be advantageous to prepare initial layout drawings to a “hand-sketch” level of detail and investigate the compatibility of the design principles presented below before further design effort is invested. The optimal position of the roundabout may not be established until geometrics are roughly investigated for various location options.

The key design parameters and methods for checking designs are summarized in the remainder of this section.

6.1 Horizontal Design

Three of the key considerations that affect horizontal design of roundabouts include design speed, path alignment, and design vehicle. These in turn influence the size of the roundabout and the design of the central island and splitter islands. This section highlights these considerations and design details.

6.1.1 Design Speed

Achieving appropriate vehicular speeds entering and traveling through the roundabout is a critical design objective as it has profound impacts on safety. A well-designed roundabout reduces vehicle speeds upon entry and achieves consistency in the relative speeds between conflicting traffic streams by requiring vehicles to negotiate the roundabout along a curved path.

Generally speaking, although the frequency of crashes is most directly tied to volume, the severity of crashes is most directly tied to speed. Therefore, careful attention to the design speed of a roundabout is fundamental to attaining good safety performance [4].

The recommended design speed of a roundabout is primarily a function of the number of lanes rather than the design speed of the intersecting roadways. The design speed of a roundabout is defined by the theoretical speed that drivers could achieve through the roundabout if taking the fastest path through the roundabout without regard to lane line striping, if present. In practice, actual speeds through the roundabout will be less than these theoretical values, as drivers will be decelerating into the roundabout, yielding to other users, and staying within their lanes (for multilane roundabouts). For single-lane roundabouts, typical maximum theoretical entering speeds of 20 to 25 mph are recommended; for multilane roundabouts, typical maximum theoretical entering speeds of 25 to 30 mph are recommended. This design technique ensures that speeds observed in practice will fall within a reasonable range.

To determine the theoretical speed of each movement, the fastest path allowed by the geometry is drawn. This is the smoothest, flattest path possible for a single vehicle given the absence of any other traffic and given that the driver ignores all lane markings, traverses the entry, and travels around the central island and through the exit. Usually the fastest possible path is the through movement, but in some cases it may be a right turn movement. Figure 7 and Figure 8 illustrate the construction of the fastest vehicle paths at a single-lane roundabout and at a multilane roundabout, respectively.

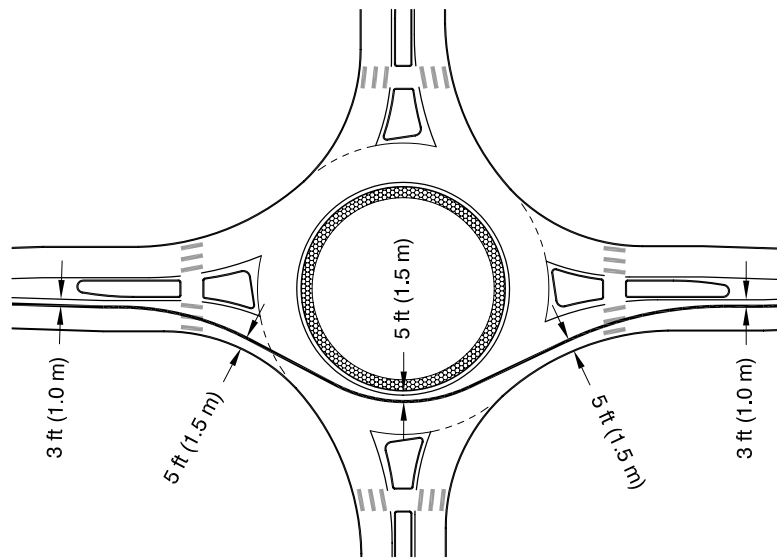

Figure 7: Fastest Vehicle Path Through a Single-Lane Roundabout

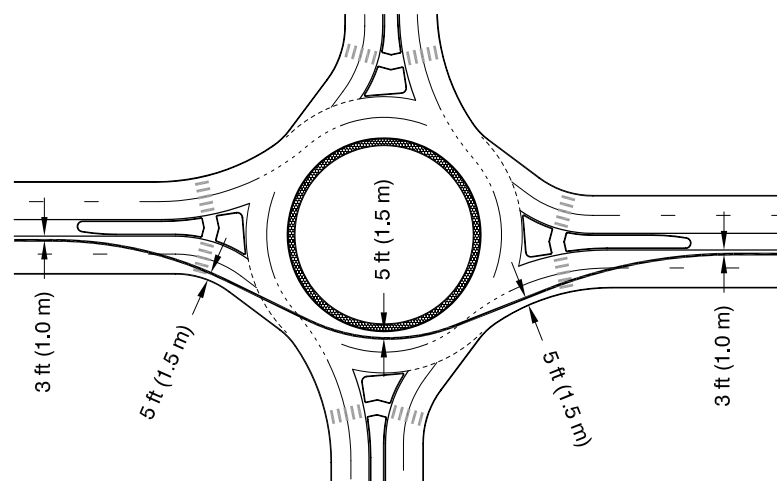

Figure 8: Fastest Vehicle Path Through a Multilane Roundabout

Figure 9 provides an example of a right-turn path. Dimensions are provided to show how the centerline of the vehicular path is drawn relative to control points (e.g., curbs). The theoretical speeds estimated from these paths are checked against the target design speed for the type of roundabout (single-lane versus multilane) to determine if the geometry produces reasonable speeds.

The fastest path should be drawn and checked for all approaches of the roundabout. Figure 10 illustrates the five critical path radii that are commonly checked for each approach.

Once the fastest paths are drawn, the above radii are measured and corresponding design speeds are calculated using standard horizontal curve guidelines from the American Association of State Highway and Transportation Officials (AASHTO) [9]. Typically, roundabouts are designed with a cross slope of 2 percent toward the outside (i.e., a superelevation of -0.02). Figure 11 displays a graphical representation of the speed-radius relationships (in U.S. Customary units).

In addition to achieving an appropriate design speed for the entry movements, another important objective is to achieve consistent speeds for all movements, which are influenced by choices on geometric elements. The key benefits of achieving speed consistency among the movements are safety related. Typically, the relationships between the speeds associated with radii R_1 , R_2 , and R_3 and radii R_1 and R_4 are of primary interest. In practice, by keeping the recommended maximum entry design speed below the recommended values, the goal of consistent speeds for all movements can be readily achieved.

There are differences of opinion on the importance of tangential versus curved exit geometry for the purpose of controlling exit speeds, particularly at the pedestrian crosswalk. Some designers advocate for a relatively tight exit radius to minimize exit speeds; however, others advocate for a more relaxed exit radius for improved drivability. Theoretical exit speeds can be checked using the above method. However, research has found that observed exit speeds are more commonly limited by circulating speeds

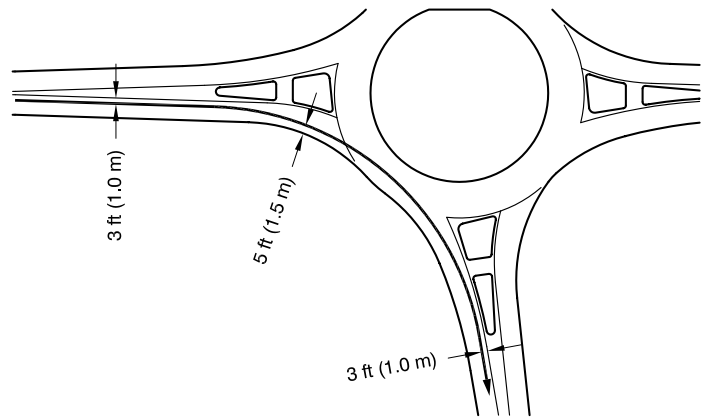

Figure 9: Example of Critical Right-Turn Movement

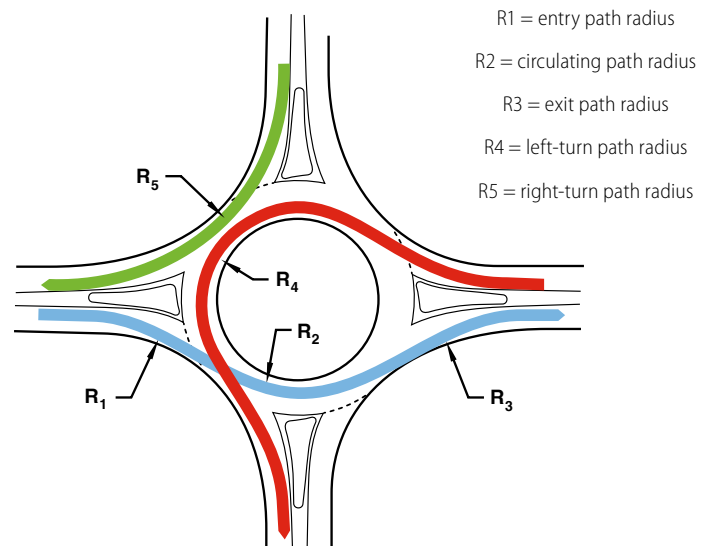

Figure 10: Vehicle Path Radii

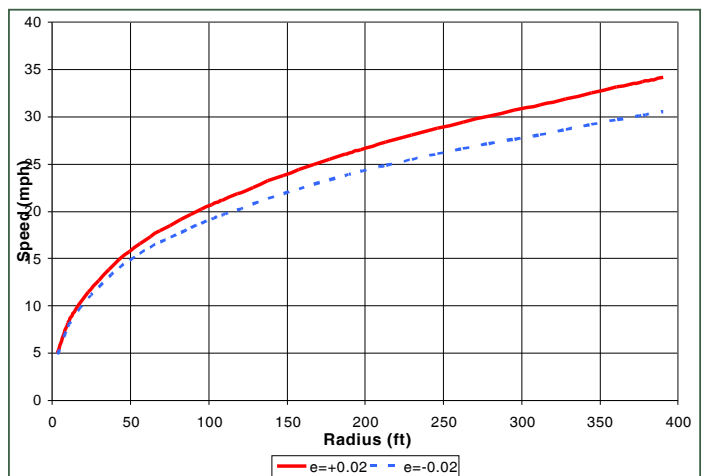

Figure 11: Speed-Radius Relationship (U.S. Customary Units)

and acceleration out of the roundabout than by the radius of the exit path. More information on calculating exit speeds can be found in the Roundabout Guide [2]. It is important to understand the relative trade-offs of design choices, and choices may vary based upon the location context.

6.1.2 Path Alignment

With multilane roundabouts, the designer should also consider the alignment of vehicles, or the natural path, to ensure the proposed geometry directs vehicles to stay within the proper lanes through the circulatory roadway and exits. Path overlap occurs when the natural paths of vehicles in adjacent lanes overlap or cross one another. The entry design should align vehicles into the appropriate lane within the circulatory roadway, using the technique shown in Figure 12 or others that promote good path alignment.

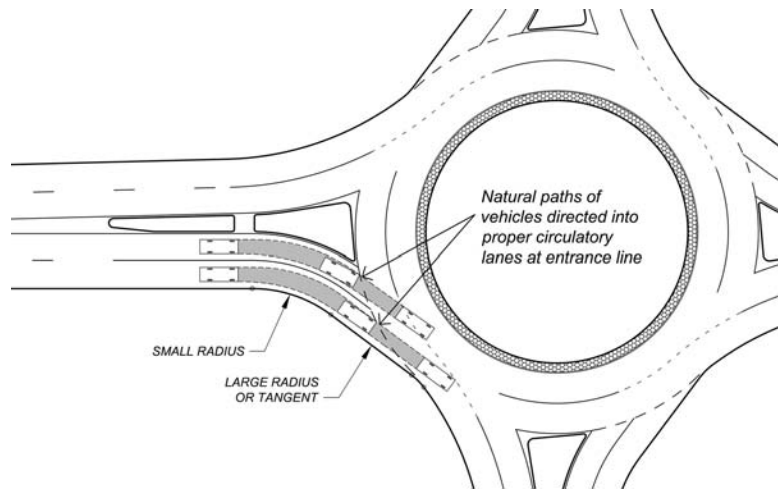

Figure 12: Design to Promote Good Path Alignment

Source: Kansas Roundabout Guide [10]

Designing multilane roundabouts with good path alignment, while also controlling entry speeds through adequate deflection, can be difficult. Strategies that improve path alignment may result in increased fastest path speeds. A good design attempts to balance the entry speed, path alignment needs, and other factors (e.g., design vehicle needs) through design iterations and checks of the various factors.

Figure 13 illustrates one possible multilane design technique in greater detail. The primary objective of this particular design technique is to locate the entry curve at the optimal placement so that the projection of the inside entry lane at the entrance line connects tangentially or nearly tangentially to the central island. The design of the exits should also provide sufficiently large exit radii and alignment to allow drivers to intuitively maintain the appropriate lane. Other techniques involve changes to approach alignment, entry curvature, and/or inscribed circle diameter; these are discussed in the Roundabout Guide. Each of these adjustments could create trade-offs; for example, increasing the inscribed circle diameter could result in faster circulatory speeds, greater land impacts, and so

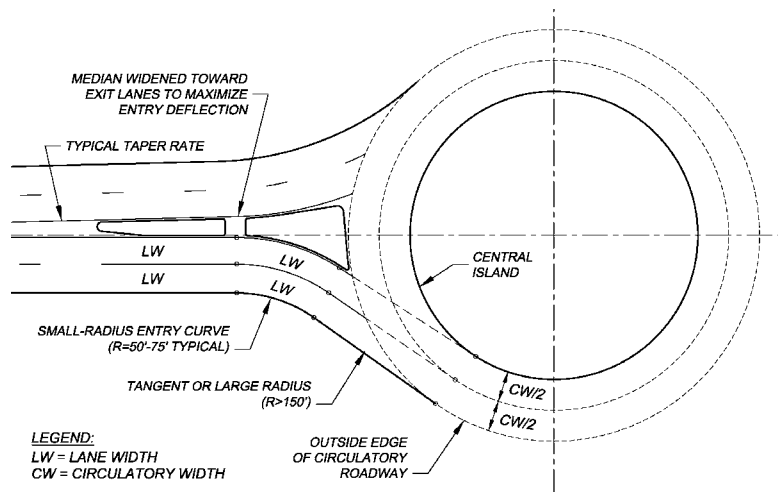

Figure 13: Possible Design Technique to Promote Good Path Alignment

Source: Kansas Roundabout Guide [10]

on. A good design attempts to balance these factors through design iteration.

Likewise, problems can also occur when the design allows for too much separation between entries and subsequent exits. Large separations between legs cause entering vehicles to join next to circulating traffic that may be intending to exit at the next leg, rather than

crossing the path of the exiting vehicles. This can create conflicts at the exit point between exiting and circulating vehicles, as shown in Figure 14.

A variety of solutions are possible to address this problem, including changes to lane configurations, changes to inscribed circle diameter, and realignment of the approaches. Figure 15 illustrates one of these possible solutions, which involves realignment of the approach legs to have the paths of entering vehicles cross the paths of the circulating traffic (rather than merging) to minimize the conflict. This significantly increases the likelihood that entering drivers making a through movement will yield to both conflicting lanes.

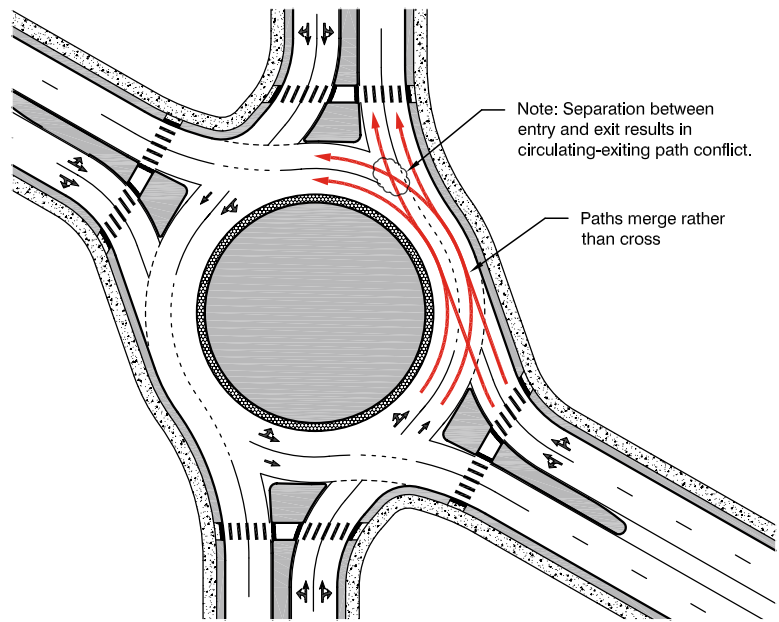

Figure 14: Exit-Circulating Conflict Caused by Large Separation between Legs

6.1.3 Design Vehicle

Large trucks, buses, and emergency vehicles often dictate many of the roundabout's dimensions, particularly for single-lane roundabouts. Therefore, the design vehicle is best identified at the start of the project and evaluated early in the design process. A truck apron will often be needed within the central island to accommodate larger design vehicles (including the common WB-62, WB-65, or WB-67 design vehicles) but maintain a relatively narrow circulatory roadway to adequately constrain passenger car speeds. Design details regarding truck aprons are provided in the "Grades" section of this document.

Appropriate vehicle-turning templates or a CAD-based computer program should be used to determine the swept path of the design vehicle through each of the turning movements. Usually, the left-turn movement is the critical path for determining circulatory roadway width while the right-turn movement is the critical path for entry and exit widths. Figure 16 illustrates an example vehicle path check.

Buses should generally be accommodated within the circulatory roadway without tracking over the truck apron, which could cause discomfort to bus occupants.

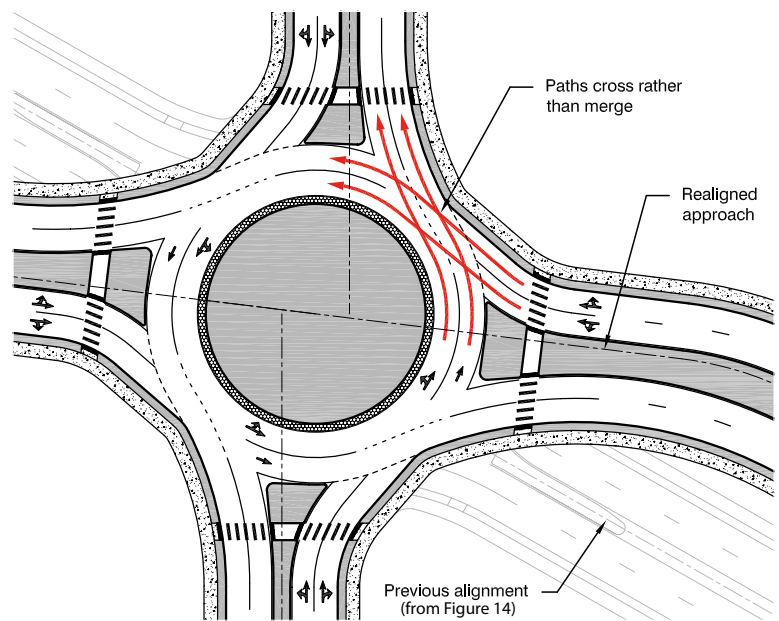

Figure 15: Realignment to Resolve Exit-Circulating Conflict

For multilane roundabouts, there are different philosophies regarding the extent to which trucks need to stay in their lane throughout their movement; these are discussed further in the Roundabout Guide.

6.1.4 Size

The size of a roundabout, measured by its inscribed circle diameter (see Figure 2), is determined by a number of design objectives, including design speed, path alignment, and design vehicles as discussed above. Selection of an initial inscribed circle diameter is the first step towards preparing a design. The selected diameter may be somewhat subjective, but its ultimate size is an output of meeting other objectives (e.g., speed control, design vehicle, etc.). Smaller inscribed circle diameters can be used for some local street or collector street intersections where the design vehicle may be a fire truck or single-unit truck. Larger inscribed circle diameters generally provide increased flexibility for the entry design to meet design criteria (e.g., speed, adequate visibility to the left, etc.) while accommodating large design vehicles. Table 2

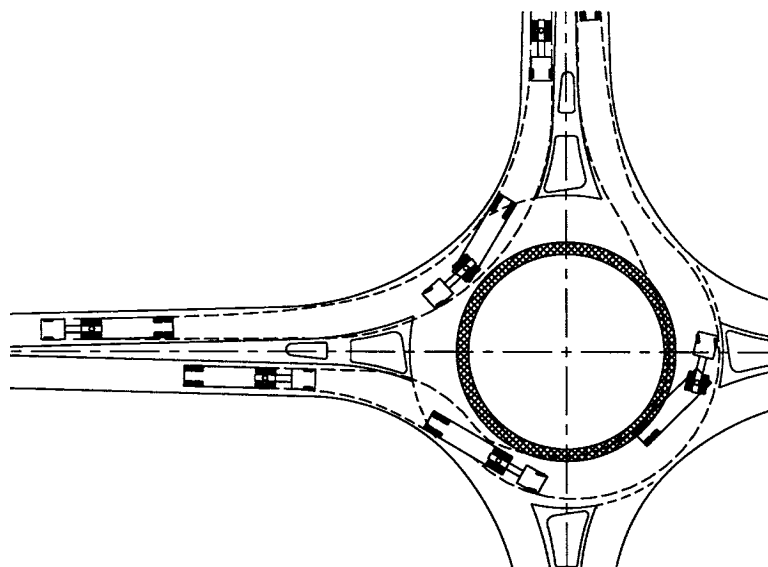

Figure 16: Example Design Vehicle Path Check

provides common ranges of inscribed circle diameters for various roundabout categories and typical design vehicles; values outside these ranges are possible but less common.

Table 2: Common Inscribed Circle Diameter Ranges

Roundabout Configuration	Typical Design Vehicle	Inscribed Circle Diameter Range*	
Mini-Roundabout	SU-30 (SU-9)	45 to 90 ft	(14 to 27 m)
Single-Lane Roundabout	B-40 (B-12)	90 to 150 ft	(27 to 46 m)
	WB-50 (WB-15)	105 to 150 ft	(32 to 46 m)
	WB-67 (WB-20)	130 to 180 ft	(40 to 55 m)
Multilane Roundabout (2 lanes)	WB-50 (WB-15)	150 to 220 ft	(46 to 67 m)
	WB-67 (WB-20)	165 to 220 ft	(50 to 67 m)
Multilane Roundabout (3 lanes)	WB-50 (WB-15)	200 to 250 ft	(61 to 76 m)
	WB-67 (WB-20)	220 to 300 ft	(67 to 91 m)

* Assumes 90-degree angles between entries and no more than four legs.

6.1.5 Central Island

The central island of a roundabout is the raised, mainly non-traversable area surrounded by the circulatory roadway. It may also include a traversable truck apron. The island is typically landscaped for aesthetic reasons and to enhance driver recognition of the roundabout upon approach. Raised central islands for single-lane roundabouts are preferred over depressed central islands, as depressed central islands are difficult for approaching drivers to recognize.

A circular central island is preferred because the constant-radius circulatory roadway helps promote constant speeds around the central island. Oval or irregular shapes may be necessary at irregularly shaped intersections or intersections with more than four legs. Raindrop-shaped islands are sometimes used in areas where certain movements do not exist, such as interchanges, or at locations where certain turning movements cannot be safely accommodated, such as roundabouts with one approach on a relatively steep grade.

The size of the central island plays a key role in determining the amount of deflection imposed on the through vehicle's path. However, its diameter is dependent upon the inscribed circle diameter and the required circulatory roadway width. Roundabouts in rural environments typically need larger central islands than urban roundabouts to enhance their visibility, accommodate larger design vehicles, enable better approach geometry to be designed in the transition from higher speeds, and be more forgiving to errant vehicles.

The central island may include enhancements (e.g., landscaping, sculptures, fountains) serving both an aesthetic purpose and providing conspicuity of the intersection for approaching motorists. These treatments should not attract pedestrians to the central island, as they should never cross the circulating roadway. Furthermore, care is needed when including any fixed objects within the central island in environments where the speeds on the approaching roadways are higher.



Photo: Skagit County Public Works Department (used with permission)

Figure 17: Use of Longer Splitter Islands in a Rural Environment (Skagit County, Washington)

6.1.6 Splitter Island

Splitter islands should be provided on all roundabouts, and these islands should be raised on all but those with small diameters. Their purpose is to provide refuge for pedestrians, assist in controlling speeds, guide traffic into the roundabout, physically separate entering and exiting traffic streams, and deter wrong-way movements. Additionally, splitter islands can be used as a place for mounting signs.

When performing the initial layout of a roundabout design, a sufficiently sized splitter island "envelope" should be identified prior to designing the entry and exits of an approach. This will ensure that the design will eventually allow for a raised island that meets the minimum dimensions (e.g., offsets, tapers, length, widths). It is recommended that control points for the splitter island envelope be identified prior to proceeding to the design of the entry and exit geometry to ensure that a properly sized splitter island will be provided.

The total length of the raised island should generally be at least 50 ft (15 m), although longer is desirable, to provide sufficient protection for pedestrians and to alert approaching drivers to the roundabout geometry. Additionally, the splitter island should extend beyond the end of the exit curve to prevent exiting traffic from accidentally crossing into the path of approaching traffic. For approaches in high-speed locations (typically rural), the splitter island should be at least 200 feet long and preferably of a length needed for the comfortable deceleration length as measured from approach speed to entry speed. The splitter island width should be a minimum of 6 ft (1.8 m) at the crosswalk to adequately

provide refuge for pedestrians, including those using wheelchairs, pushing a stroller, or walking a bicycle.

There are benefits to providing larger splitter islands. An increase in the splitter island width results in greater separation between the entering and exiting traffic streams of the same leg and increases the time for approaching drivers to distinguish between exiting and circulating vehicles. In this way, larger splitter islands can help reduce confusion for entering motorists. However, increasing the width of the splitter islands generally requires increasing the inscribed circle diameter to maintain speed control on the approach. Thus, these safety benefits may be offset by higher construction cost and greater land impacts.

Standard AASHTO guidelines for island design should be followed for the splitter island. This includes using larger nose radii at approach corners to maximize island visibility and offsetting curb lines at the approach ends to create a funneling effect. The funneling treatment also aids in reducing speeds as vehicles approach the roundabout. Additional details can be found in the Roundabout Guide.

6.2 Pedestrian Design Treatments

Wherever possible, sidewalks at roundabouts should be set back from the edge of the circulatory roadway by a landscape buffer. The buffer discourages pedestrians from crossing to the central island or cutting across the circulatory roadway of the roundabout, and it helps guide pedestrians with vision impairments to the designated crosswalks. A buffer width of 5 ft (1.5 m) (minimum 2 ft [0.6 m]) or greater is recommended, and it is best to plant low shrubs or grass in the area between the sidewalk and curb to maintain sight distance needs. Figure 18 shows this technique.

Crosswalks should be located in vehicle-length increments away from edge of the circulatory roadway. A typical (and minimum) crosswalk setback of 20 ft (6 m) is recommended. The raised splitter island width should be a minimum of 6 ft (1.8 m) at the crosswalk to adequately provide shelter for persons pushing a stroller or walking a bicycle. At some roundabouts, it may be desirable to place the crosswalk two or three car lengths (45 ft [13.5 m] or 70 ft [21.5 m]) back from the edge of the circulatory roadway. This longer setback is

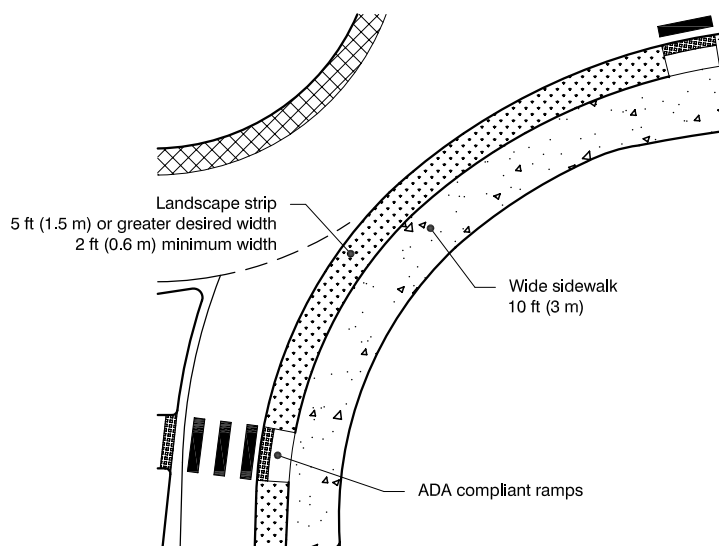

Figure 18: Sidewalk Treatments

typically used in situations with relatively high volumes of pedestrian crossings that may cause queues on the exit roadway to frequently extend into the circulatory roadway. Other treatments for the accommodation of pedestrians, including signalization, are discussed in the Roundabout Guide.

6.3 Bicycle Design Treatments

Bicycle lanes are not recommended within the circulatory roadway of roundabouts, as it has been demonstrated internationally to have adverse safety effects (see the Roundabout Guide). Where bicycle lanes or shoulders are used on approach roadways, they should be terminated in advance of roundabouts. Bicyclists may choose to merge with traffic and travel like other vehicles, or they may choose to exit the roadway onto the sidewalk (or shared use path) and travel as pedestrians.

The full width bicycle lane should normally end at least 100 feet before the edge of the circulatory roadway. An appropriate taper (a rate of 7:1 is recommended) should be provided to narrow the combined travel lane and bike lane width down to the appropriate width necessary to achieve desired motor vehicle speeds on the roundabout approach. Because some bicyclists may not feel comfortable traversing some roundabouts in the same manner as other vehicles, bicycle ramps can be provided to allow access to the sidewalk or a shared use path at the roundabout. Figure 19 displays a possible layout of bicycle treatments. To minimize confusion between bicycle ramps and pedestrian ramps, the detectable warning surfaces are placed at the top of the

bicycle ramps rather than at the bottom as is the practice with pedestrian ramps.

In general, bicycle ramps should only be used where the roundabout complexity or design speed may result in less comfort for some bicyclists. Ramps may not be needed at urban one-lane roundabouts, as the low-speed and lower-volume environment will typically allow cyclists to navigate as comfortably as vehicles.

6.4 Sight Distance and Visibility

Adequate sight distance and visibility is needed for a roundabout to operate safely. These factors can be contradictory: sight distance at the roundabout can be increased in some cases at the expense of the visibility of the roundabout from a distance. Evaluation of sight distance at roundabouts includes both intersection sight distance and stopping sight distance. The fundamental principles of both forms of sight distance are the same at roundabouts as for other types of intersections and roadways.

Intersection sight distance is evaluated at each entry to ensure a driver can see and safely react to potentially conflicting vehicles. Providing intersection sight distance ensures drivers can safely enter the circulatory roadway without impeding the flow of traffic within the circulatory roadway. Figure 20 illustrates the measurement of intersection sight distance.

As can be seen in the exhibit, the distance between the entering vehicle and the circulatory roadway is fixed. The other legs of the sight distance "triangle" are based on two conflicting approaches that are typically checked independently:

1. *Entering stream, comprised of vehicles from the immediate upstream entry. The speed for this movement can be approximated using the average of the entering speed and circulating speed.*
2. *Circulating stream, comprised of vehicles that entered the roundabout prior to the immediate upstream*

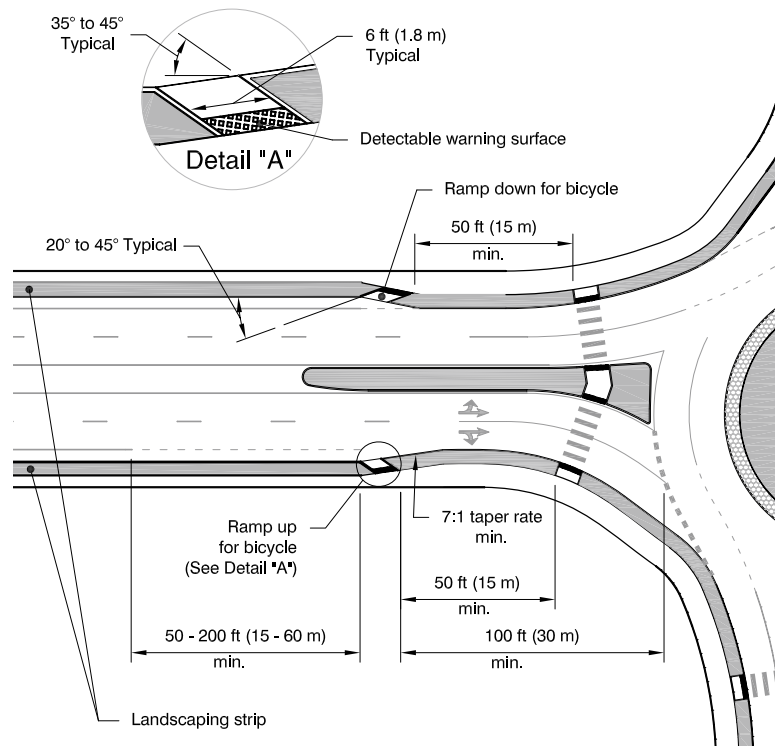

Figure 19: Possible Bicycle Design Treatments

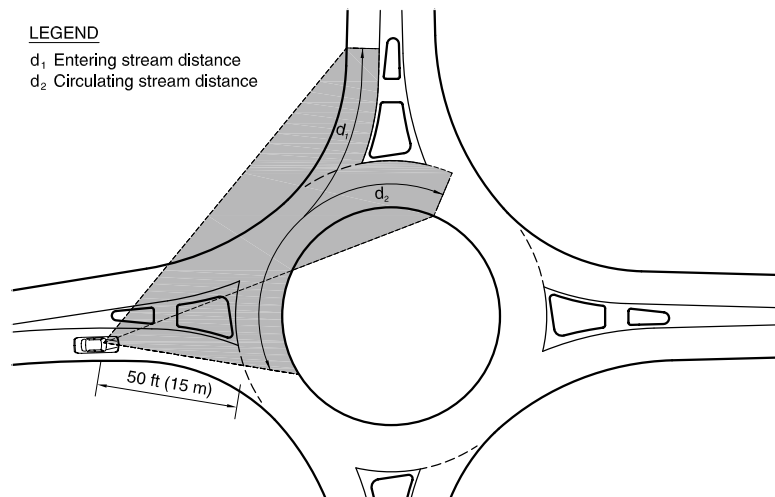

Figure 20: Intersection Sight Distance

entry. This speed can be approximated using the speed of left turning vehicles.

In both cases the distance is a function of the speed of those vehicles and a design value of the critical headway that drivers can reasonably be expected to accept.

Detailed design guidelines for evaluating intersection sight distance are provided in the Roundabout Guide.

Stopping sight distance should be provided at every point within a roundabout and on each entering and exiting approach, as illustrated in Figure 21. The required distance is based on speed, as determined from the fastest path speed checks, and can be calculated using AASHTO guidelines.

As shown in Figure 20 and Figure 21, sight distance needs may limit the height of landscaping and objects around the outer edge of the central island. In general, it is recommended to provide no more than the minimum required intersection sight distance on each approach. Excessive intersection sight distance can lead to higher vehicle speeds that may reduce the safety of the intersection.

6.5 Vertical Design

As a general practice, a cross slope of 2 percent away from the central island should be used for the circulatory roadway on single-lane roundabouts. This technique of sloping outward is recommended because it:

- Promotes safety by raising the height of the central island and improving its visibility;
- Promotes lower circulating speeds;
- Minimizes breaks in the cross slopes of the entrance and exit lanes; and
- Drains surface water to the outside of the roundabout.

Figure 22 displays a typical section for a single-lane roundabout with a truck apron. Where truck aprons are used, the slope of the apron should generally be 1 to

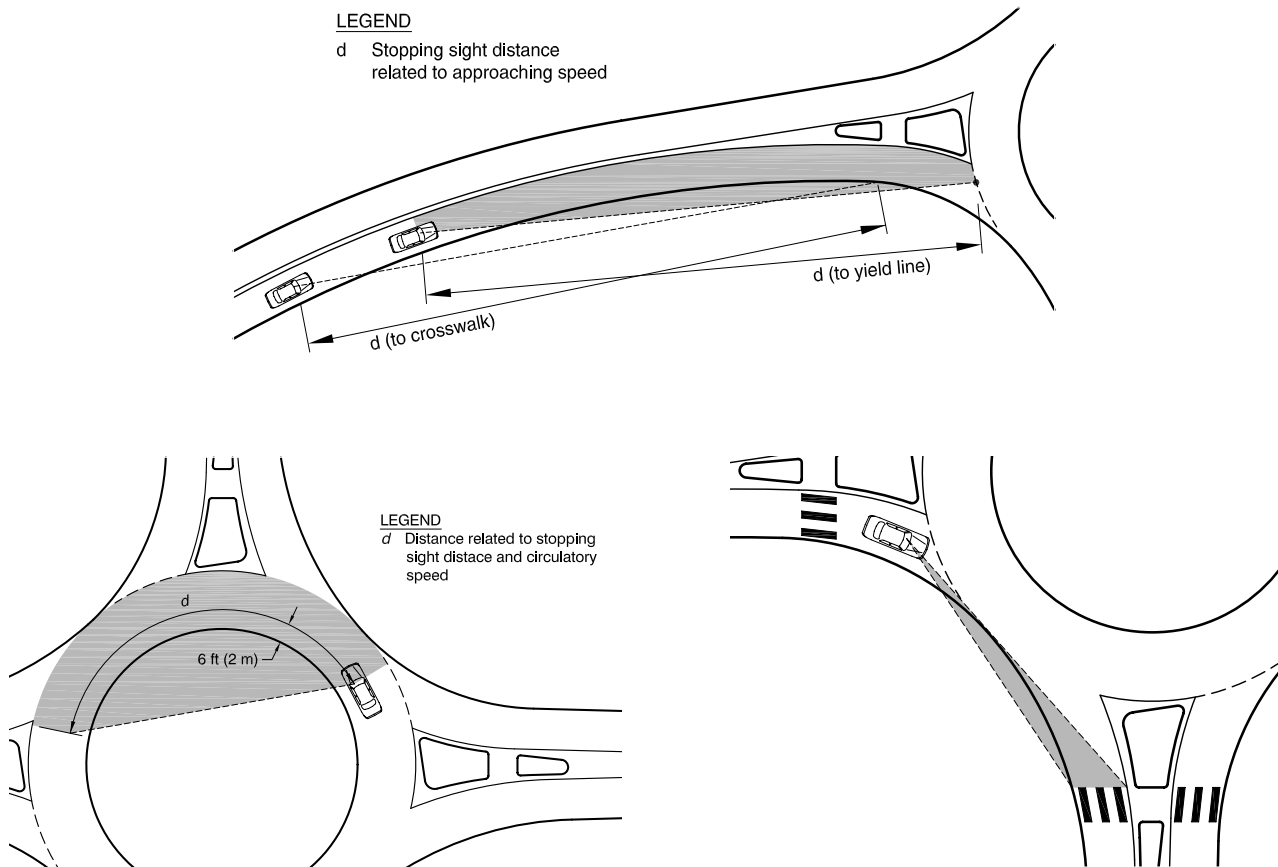

Figure 21: Stopping Sight Distance

2 percent; greater slopes may increase the likelihood of loss-of-load incidents. Examples of traversable curb details can be found in the Roundabout Guide.

There are a variety of possible methods for the vertical design of a circulatory roadway within a multilane roundabout, and many are the byproduct of fitting a roundabout to its topography. The two most commonly used methods are the following:

- **Outward sloping** – This method, used at single-lane roundabouts and some multilane roundabouts, is the most common type of vertical design for roundabouts in the United States. The circulatory roadway is graded independently of the rest of each approach at a typical outward slope of 2 percent (common practice ranges from 1.5 percent to 3 percent). This method maximizes visibility of the central island and minimizes drainage costs but may in some cases create adverse combinations of forces on trucks that may increase the possibility of load shifting or overturning.
- **Crowned circulatory roadway** – This method, used at some multilane roundabouts, provides a crown on the circulatory roadway with approximately two thirds of the width sloping toward the central island and one third sloping outward. This method may help to physically separate turning movements within the roundabout, and it may help with truck circulation in reducing the potential for load shifting or overturning in some cases. This method increases drainage costs by requiring drainage on both sides of the circulatory roadway and can reduce visibility of the central island unless other measures are taken (mounding, signs, etc.).

It is generally not desirable to locate roundabouts in locations where grades through the intersection are greater than four percent, although roundabouts have been installed on grades of 10 percent or more. Care is needed when designing roundabouts on steep grades. On approach roadways with downgrades steeper than 4 percent, it is more difficult for entering drivers to slow or stop on the approach (as with any intersection). At roundabouts on crest vertical curves with steep approaches, driver sight lines may be compromised unless the vertical design is adjusted. In addition, significant slope breaks within the roundabout can create potential problems for semi-trailer trucks, including load shifting and overturning.

Steep gradients at entries and exits should be avoided or flattened to minimize grade breaks at the entry and

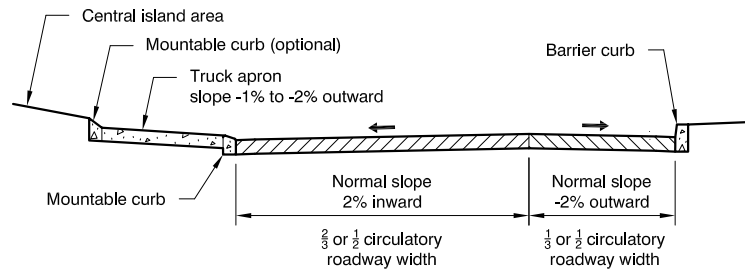

Figure 22: Typical Circulatory Roadway Section with Truck Apron

ensure that users are able to safely enter and exit the circulatory roadway. This area often requires pavement warping or cross-slope transitions to provide an appropriate cross-slope transition rate through the entire transition area. Grading the vertical profile should also ensure that adequate sight distance is provided for the intersection and entry. Adjustments to the circulatory roadway cross slope may be required to meet these criteria, but should be balanced with the effects on the circulatory roadway.

6.6 Pavement Markings and Signs

At roundabouts, pavement markings and signs work together to create a comprehensive system to guide and regulate road users. In order for pavement markings at roundabouts to provide appropriate guidance, the following general principles should be considered:

- Markings and signing are integral to roundabout design, especially for multilane roundabouts. Markings, in particular, need to be considered at the preliminary design stages of the roundabout, rather than fitting them in later in the design process.
- Markings and signs should facilitate through and turning movements in a manner such that drivers choose the appropriate lane when approaching a roundabout and then do not need to change lanes within the circulatory roadway before exiting in their desired direction.
- The Federal Highway Administration has published the 2009 edition of the *Manual on Uniform Traffic Control Devices* [11], which includes major revisions and additions related to signage and markings at roundabouts. For more detailed guidelines, designers should refer to the 2009 MUTCD and the Roundabout Guide.

6.6.1 Pavement Markings

Typical pavement markings for roundabouts delineate the entries, exits, and the circulatory roadway, providing guidance for pedestrians and vehicle operators. Example markings for single-lane and multilane roundabouts are shown in Figure 23. Pedestrian crossing markings (shown in the figure) and yield line markings (not shown) may be used at any roundabout. Bicycle lanes within the circulatory roadway are prohibited.

As shown in Figure 23, solid white lane lines are recommended on multilane approaches and departures to discourage lane changes in these areas. Multilane roundabouts should also have lane line markings within the circulatory roadway to channelize traffic to the appropriate exit lane. These circulatory roadway lane line markings and lane-use arrows (described below) should be designed to work together with approach lane line markings to ensure that once drivers have chosen the appropriate entry lane on the approach, they do not have to change lanes within the roundabout to exit at their desired exit. One possible pattern for marking circulatory roadway lane lines is illustrated in Figure 24. However, there are other possibilities for the marking pattern of lane lines within the circulatory roadway of roundabouts; these are discussed in the Roundabout Guide.

In general, lane-use arrows should be used at roundabout approaches with exclusive turn lanes and at other multilane roundabouts where lane-use arrows will improve lane use by drivers. There are four different options for the design of lane-use arrows on the approach to roundabouts as shown in Figure 25. Normal lane-use arrows may be used with or without an oval symbolizing the central island. Alternatively, the “fish-hook” arrows shown on the right, which also contain an optional oval symbolizing the central island, may be



Photo: Casey Bergh (used with permission)

Figure 24: Example Markings for Multilane Roundabout (Bend, Oregon)

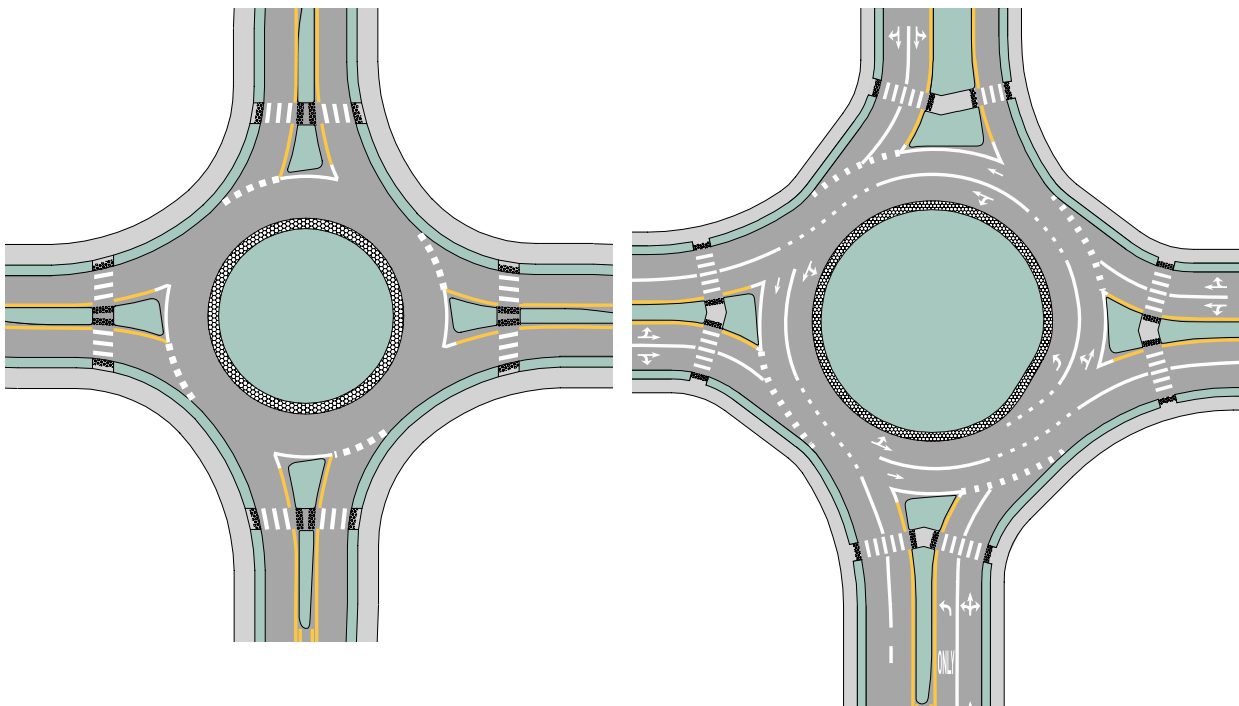

Figure 23: Example Markings

used. In choosing a lane-use arrow design, designers should consider the general practices within a city, region, or State.

6.6.2 Signing

The overall concept for roundabout signing is similar to general intersection signing. Proper regulatory control, advance warning, and directional guidance are required to avoid driver expectancy-related problems. Signs should be located where they have maximum visibility for road users but a minimal likelihood of even momentarily obscuring more vulnerable users including pedestrians, motorcyclists, and bicyclists. Signing needs are different for urban and rural applications and for different categories of roundabouts.

Figure 26 shows typical layouts of regulatory and warning signs for single-lane and multilane roundabouts. For multilane roundabouts, lane-use signs can use the same range of lane-use arrow options as described for pavement markings.

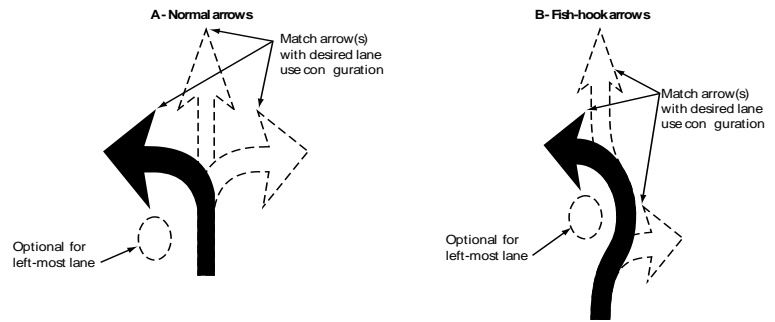

Figure 25: Lane-Use Arrow Options for Roundabout Approaches

Guide signs at roundabouts generally consist of exit guide signs and advance guide signs. Exit guide signs are generally recommended at all roundabout exits to designate the destinations of each departure leg. These signs are similar to conventional intersection direction signs or directional route marker assemblies, except that a diagonal upward pointing arrow is used, as shown in Figure 27. These signs can be placed either on the right hand side of the roundabout exit or in the splitter island (recommended where feasible to maximize sign visibility). Advance destination guide signs should

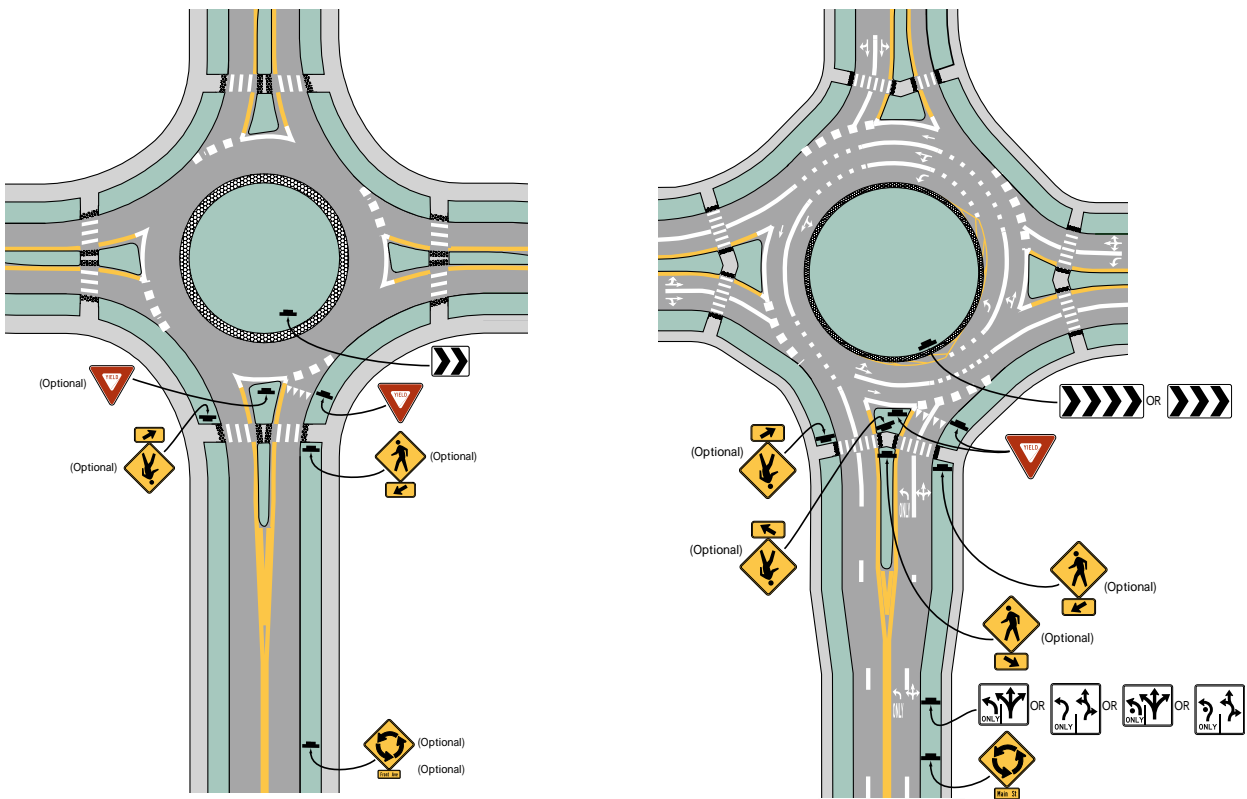

Figure 26: Example of Regulatory and Warning Sign Layouts

be used in all rural locations and in urban/suburban areas where appropriate. Additional examples can be found in the MUTCD.

6.7 Lighting

Roundabouts, including their pedestrian crossing areas and bicycle design features, should be conspicuous and visible to approaching drivers. The overall illumination of the roundabout should be based on local and national guidelines for street lighting. The Design Guide for Roundabout Lighting [12], published by the Illuminating Engineering Society (IES), is the primary resource that should be consulted in completing a lighting plan for all roundabout types. Local illumination standards should also be considered when establishing the illumination at the roundabout to ensure that the lighting is consistent. The Roundabout Guide provides a more detailed summary of lighting principles and guidelines.

6.8 Landscaping

Landscaping of roundabouts plays an important role in improving the aesthetics of an area, as shown in Figure 28. However, landscaping has a number of functional purposes:

- It makes the center island more conspicuous;
- It focuses driver attention on key conflict areas by blocking the view of other areas; and
- It discourages pedestrian traffic through the center island.

Any landscaping that is provided should be designed to minimize roadside hazards, particularly in higher speed environments, and to maintain adequate stopping and intersection sight distance throughout the roundabout.

6.9 Other Design Details and Applications

More design details and applications of roundabouts exist than can be covered in this technical summary; however, some of

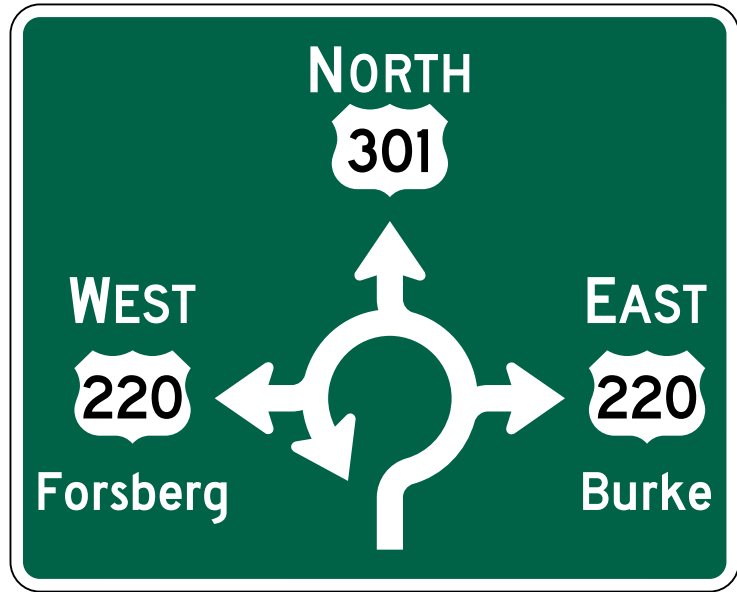

Figure 27: Example Exit and Advance Diagrammatic Guide Signs



Figure 28: Use of Selective Landscaping (Coralville, Iowa)

Photo: Lee Rodegerdt (used with permission)

the more notable considerations are described below:

- **Right-turn bypass lanes** – Roundabouts can employ right-turn bypass lanes similar to those used at conventional intersections. Bypass lanes are designed either to yield to exiting traffic or to form an additional lane next to exiting traffic (which may then merge into the exiting traffic).
- **Access management** – Driveways in the vicinity of roundabouts may experience restrictions in access similar to those in the vicinity of signalized intersections. Roundabouts may offer the opportunity to include driveways as a curb cut or a fully developed approach with splitter islands depending on the volume characteristics and other factors.
- **At-grade rail crossings** – At-grade rail crossings through or near a roundabout are possible but introduce challenges related to the control of the rail crossing itself, queue clearance on the tracks, and the associated effects on the roundabout.

- **Evacuation routes** – Roundabouts have been located on evacuation routes and have had flow reversed as needed to facilitate evacuation.
- **Bus stops** – Bus stops can be provided on either the entry or exit side of a roundabout. Bus stops should not be provided within the circulatory roadway. Pedestrian access to and from the bus stop, including the location of the bus stop relative to the nearest crosswalk, should be carefully considered.

Refer to the Roundabout Guide for additional information on these and other topics.

Section 7: Costs

Construction costs for roundabouts vary widely, from tens of thousands of dollars for minor retrofits of small intersections using existing curb lines, existing pavement, and no landscaping to millions of dollars for major reconstruction of large intersections with significant earthwork, structures, and landscaping. Right-of-way costs also vary widely depending on impact area and land uses. As a result, a case-by-case evaluation of construction costs is needed for a reasonable assessment.

A benefit-cost analysis may be useful in alternatives analysis, as it recognizes that not all of the benefits and costs of an alternative can be quantified by pure construction costs. The safety, operational, and environmental benefits of roundabouts can be quantified and compared to the initial construction and ongoing maintenance cost over the life cycle of the roundabout. While initial construction costs might be higher for a roundabout in a retrofit situation (they are often comparable in new installations), the roundabout's ongoing maintenance is often cheaper than for signalized intersections, as there is typically no

signal hardware to power, maintain, and keep current in terms of signal timing. Finally, while many factors influence the potential service life of a roundabout (types of construction materials, weather conditions, traffic conditions, growth in the area, etc.), roundabouts can often serve for longer periods of time between major upgrades (repaving, reconstruction, etc.) than comparable signalized intersections. More detail on estimating lifecycle benefits and costs can be found in the Roundabout Guide.

Section 8: References

1. Robinson, B. W., L. Rodegerdts, W. Scarbrough, W. Kittelson, R. Troutbeck, W. Brilon, L. Bondzio, K. Courage, M. Kyte, J. Mason, A. Flannery, E. Myers, J. Bunker, and G. Jacquemart. *Roundabouts: An Informational Guide*. Report FHWA-RD-00-067. FHWA, U.S. Department of Transportation, June 2000.
2. Rodegerdts, L. A., et al. *Roundabouts: An Informational Guide, 2nd Edition*. National Cooperative Highway Research Program Project 03-65A. Transportation Research Board, National Academy of Sciences, Washington, D.C. Work in progress; estimated publication 2010.
3. Rodegerdts, L. A., W. E. Scarbrough, and J. A. Bansen. *Technical Summary on Mini-Roundabouts*. FHWA, Washington, D.C., 2010.
4. Rodegerdts, L., M. Blogg, E. Wemple, E. Myers, M. Kyte, M. Dixon, G. List, A. Flannery, R. Troutbeck, W. Brilon, N. Wu, B. Persaud, C. Lyon, D. Harkey, D. Carter. *Roundabouts in the United States*. National Cooperative Highway Research Program Report 572. Transportation Research Board, National Academies of Science, Washington, D.C., 2007.
5. Persaud, B. N., R. A. Retting, P. E. Garder, and D. Lord. *Crash Reductions Following Installation of Roundabouts in the United States*. Insurance Institute for Highway Safety, Arlington, Virginia, March 2000.
6. Cunningham, R. B. *Maryland's Roundabouts: Accident Experience and Economic Evaluation*. Traffic Development & Support Division, Office of Traffic and Safety, State Highway Administration, Maryland Department of Transportation, March 2007.
7. Hughes, Ronald G., et al. NCHRP 03-78A: *Crossing Solutions at Roundabouts and Channelized Turn Lanes for Pedestrians with Vision Disabilities*. Transportation Research Board, National Academies of Science, Washington, D.C. Work in progress, estimated publication 2010.
8. Transportation Research Board. *Highway Capacity Manual*. Transportation Research Board, National Academies of Science, Washington, D.C. Work in progress, estimated publication 2010.
9. American Association of State Highway and Transportation Officials (AASHTO). *A Policy on Geometric Design of Highways and Streets*. AASHTO, Washington, D.C., 2004.
10. Kittelson & Associates, Inc. and TranSystems Corporation. *Kansas Roundabout Guide: A Supplement to FHWA's Roundabouts: An Informational Guide*. Kansas Department of Transportation, Topeka, Kansas, October 2003.
11. Federal Highway Administration (FHWA). *Manual on Uniform Traffic Control Devices*. FHWA, Washington, D.C., 2009.
12. Illuminating Engineering Society. *Design Guide for Roundabout Lighting*. Publication IES DG-19-08. Illuminating Engineering Society of North America, New York, February 2008.

For More Information

Ed Rice

Intersection Safety Team Leader,
FHWA Office of Safety

202.366.9064

ed.rice@dot.gov

Visit FHWA's intersection safety web site to download this and other case studies highlighting proven intersection safety treatments from across the country:

<http://safety.fhwa.dot.gov/intersection>



U.S. Department of Transportation
Federal Highway Administration